

# User Manual

# STAR T3 Series UPS

6/10 kVA



[www.allis.com.tw](http://www.allis.com.tw)

# Contents

- 1. Presentation ..... 1**
  - 1.1 General Description ..... 1
  - 1.2 System Configuration ..... 2
  - 1.3 Front Panel ..... 3
    - ↳ LCD ..... 3
    - ↳ LED ..... 3
  - 1.4 Rear Panel ..... 4
    - ↳ 6/10 kVA ..... 4
    - ↳ Extended Battery Bank ..... 5
- 2. Installation ..... 6**
  - 2.1 Unpacking ..... 6
  - 2.2 Installation ..... 7
    - ↳ Standard ..... 7
    - ↳ External Battery ..... 8
    - ↳ Parallel ..... 9
  - 2.3 Connection to communication ..... 10
    - 2.3.1 Standard ..... 10
      - ↳ RS-232 ..... 10
    - 2.3.2 Optional Interface Cards ..... 11
      - ↳ USB Card ..... 11
      - ↳ DB9 Dry Contact Card ..... 11
      - ↳ AS400 Card ..... 12
      - ↳ SNMP/HTTP Agent ..... 12
- 3. Operation ..... 13**
  - 3.1 LCD and LED Display ..... 13
    - ↳ LCD ..... 13
    - ↳ LED ..... 15
  - 3.2 Starting up/ Shutting down the UPS ..... 16
  - 3.3 Operation Modes ..... 17
  - 3.4 Configuration Settings ..... 18
    - ↳ Output Voltage / Frequency ..... 18
    - ↳ Bypass Voltage ..... 19
- 4. Maintenance ..... 20**
  - 4.1 General Maintenance ..... 20
    - ↳ Environment ..... 20
    - ↳ Storing the UPS and Battery ..... 20
    - ↳ Replace the Battery ..... 20
  - 4.2 Replacing the New Battery ..... 21
  - 4.3 Testing the New Battery ..... 21
  - 4.4 Recycling the Used Battery ..... 21
  - 4.5 Maintenance Bypass ..... 22
    - ↳ Switch to bypass ..... 22
    - ↳ Return from bypass to normal mode ..... 22
- 5. Troubleshooting ..... 23**
  - ↳ LCD ..... 23
  - ↳ LED ..... 25
- 6. Appendix ..... 28**
  - 6.1 Specifications ..... 28
    - ↳ General Specification ..... 28
    - ↳ Battery Run Time ..... 29
  - 6.2 Contact Information ..... 30

## Important Safety Instructions

**SAVE THESE INSTRUCTIONS.** This UPS unit operates from utility power and contains a number of high current back-up batteries, the information is important to all personnel involved. **Please read this manual first before installation and operation of the UPS.**

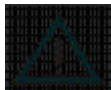

### Safety of Persons

- ⚠ Opening or removing the cover of the unit may expose you to lethal voltage within the unit even it is apparently not operated and the input wiring is disconnected from electrical source.
- ⚠ Refer all UPS and battery service to authorized service personnel from the manufacture or agent authorized by the manufacturer.
- ⚠ Do not dispose of battery in a fire. The battery may explode.
- ⚠ Do not open or damage the battery. Battery acid is toxic and harmful to eyes and skin.
- ⚠ The following precautions should be observed when working on batteries:
  - ? Remove watches, rings, and other metal objects.
  - ? Use tools with insulated handles.



### Product Safety

- ⚠ Install the UPS in a clean environment, free from moisture, flammable gases or fumes and corrective substances.
- ⚠ Keep the UPS on a flat, stable surface with **50cm** space around it for proper ventilation.
- ⚠ Operate the UPS in an indoor environment only in an ambient temperature range of **32°F to +104°F (0°C to +40°C)**.

The UPS is designed for data processing equipment. It is not intended for use with life support and other designated "critical" devices.
- ⚠ Maximum load must not exceed that shown on the UPS rating label.
- ⚠ Storing magnetic media on top of the UPS may result in data loss or corruption.
- ⚠ Once batteries have reached the end of their life, ensure they are disposed properly. **REFER TO YOUR LOCAL LAWS AND REGULATIONS FOR BATTERY DISPOSAL REQUIREMENTS.**
- ⚠ The UPS must be handled with care and attention since the high energy stored within the batteries. It must always be kept in the position The battery should be maintained at regular intervals marked on the external packaging and must not be dropped.
- ⚠ Please keep the exhaust holes of UPS unobstructed.
- ⚠ The battery should be maintained at regular intervals



### Special Precautions

- ⚠ The UPS should be installed according to the instructions in this manual. Failure to do so could result in safety issues. It could also invalidate your warranty.
- ⚠ **DO NOT CONNECT** equipment that could overload the UPS or demand half-wave rectification from the UPS, for example: **electric drills, vacuum cleaners, printers or hair dryers.**
- ⚠ Adjust only those controls that are listed by the Adjustment Section. If the unit does not operate normally by following the operating instructions, contact the sales representatives.

### Icon Usage

These icons may be found in the contents.



**WARNING:** Obvious danger to personnel or equipment.

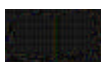

**CAUTION:** Possible danger to personnel or equipment

**Important information**

## ***Limited product warranty and policy***

### **✂ Limited Product Warranty-**

AEC warrants this equipment, when properly applied and operated within specified conditions, against faulty materials or workmanship for a period of 24 months after the date of purchase. For equipment located outside Taiwan, AEC only covers faulty parts. AEC products repaired or replaced pursuant to this warranty shall be warranted for the unexpired portion of the warranty applying to the original product. This warranty applies only to the original purchaser.

This warranty does not cover shipping costs, installation costs, maintenance and service items, calibration and adjustment. Repair or replacement of a defective part, or the crediting to the user of the value thereof, does not extend the original warranty period.

### **✂ Warranty policy-**

The warranty shall be void if (a) the equipment is damaged by the customer, is improperly used, is subjected to an adverse operating environment, or is operated outside the limits of its electrical specifications; (b) the equipment is repaired or modified by anyone other than AEC or AEC-approved personnel; or (c) has been used in a manner contrary to the product's operating manual or other written instructions. All claims under this warranty must be submitted in writing to AEC within 30 days of the occurrence or the claim will not be considered. This warranty does not include damage resulting from accident or misuse.

AEC reserves the right to determine whether the damage to the connected equipment is due to malfunction of the AEC product by requesting the equipment in question to be sent to AEC for examination. This policy is above and beyond, only to the extent needed, of that provided by any coverage of connected equipment provided by other sources, including, but not limited to, any manufacturer's warranty and/or any extended warranties.

EXCEPT AS PROVIDED ABOVE, AEC MAKES NO WARRANTIES, EXPRESS OR IMPLIED, INCLUDING WARRANTIES OF MERCHANTABILITY AND FITNESS FOR A PARTICULAR PURPOSE.

EXCEPT AS PROVIDED ABOVE, IN NO EVENT WILL AEC BE LIABLE FOR DIRECT, INDIRECT, SPECIAL, INCIDENTAL OR CONSEQUENTIAL DAMAGES ARISING OUT OF THE USE OF THIS PRODUCT, EVEN IF ADVISED OF THE POSSIBILITY OF SUCH DAMAGE. Specifically, AEC is not liable for any costs, such as lost profits or revenue, loss of equipment, loss of use of equipment, loss of software, loss of data, costs of substitutes, claims by third parties or otherwise. Coverage also does not apply to connected medical and industrial equipment.

To receive service under this warranty, you must be the original purchaser/user of the product in question. You must obtain a Returned Material Authorization (RMA) number from AEC. Products must be returned to AEC with transportation charges prepaid and must be accompanied by a brief description of the problem encountered and proof of date and place of purchase.

The policy of AEC is one of continuous improvement. Specifications are subject to change without notice.

# 1. Presentation

## 1.1 General Description

The continuity of electrical power is an essential requirement for critical load operations .The Uninterruptible Power System (UPS) is a compact and quiet solution for power protection of computer, server and office equipment.

To choose the UPS as your equipment protector is a wise investment as it supplies reliable, pure and stable power at an affordable price.

### **Feature & Benefits:**

- ✘ True on-line double conversion
- ✘ PWM technologies w/ IGBTs
- ✘ Wide input voltage range
- ✘ DC Start
- ✘ Battery self-test
- ✘ Microprocessor based control
- ✘ User-friendly LCD or LED
- ✘ Communication ports: Standard RS232 and optional communication slot for either DB9, USB, AS-400 or SNMP/HTTP card.
- ✘ Light weight unit
- ✘ Optional external battery slot for long runtime requirement
- ✘ DSP Technology
- ✘ Parallel redundancy capability

### **Application:**

- ✘ Computers
- ✘ Network Servers
- ✘ Workstations
- ✘ Wireless Communication
- ✘ Other Electronic Peripherals

## **1. Presentation**

### **1.2 System Configuration**

**6kVA**: 260W x 717H x 570D mm / 90 kgs

**10kVA**: 260W x 717H x 570D mm / 93 kgs



# 1. Presentation

## 1.3 Front Panel

### ↳ LCD

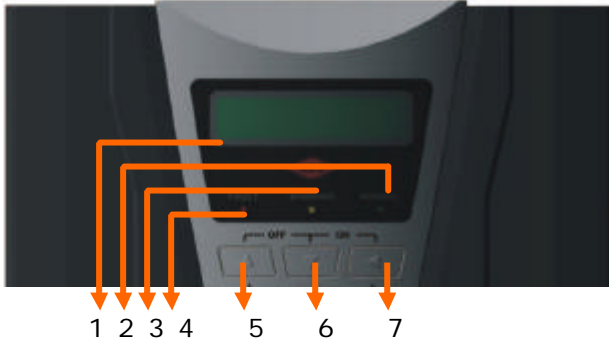

- 1. 2-line LCD Display
- 2. Normal LED (green)
- 3. Warning LED (yellow)
- 4. Fault LED (red)
- 5. Select-up button
- 6. Select-down button
- 7. Enter button
- 5-6. Off button
- 6-7. On button
- 5-7. Test/Silence button

### ↳ LED

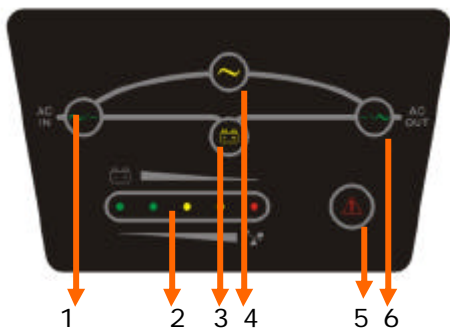

- 1. Line LED (green)
- 2. Load & Battery Capacity LEDs
- 3. Battery LED (yellow)
- 4. Bypass LED (yellow)
- 5. Fault LED (red)
- 6. Inverter LED (green)
- 7. Select-up button
- 8. Select-down button
- 9. Enter button
- 7-8. Off button
- 8-9. On button & Test/Silence button

# 1. Presentation

## 1.4 Rear Panel

### ↳ 6/10 kVA

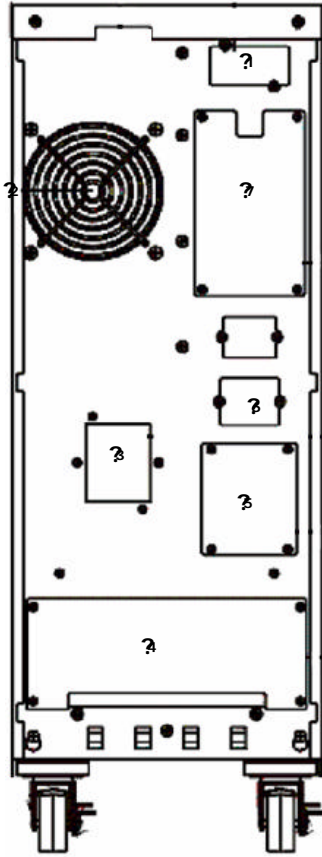

6 kVA

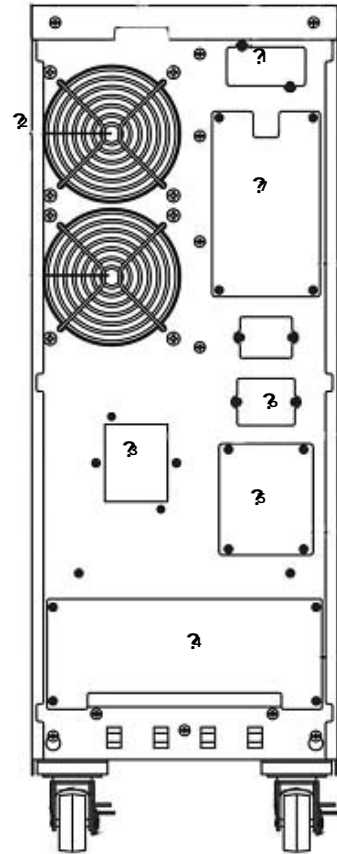

10 kVA

1. Communication ports: Standard RS232 Port & DB9, USB, AS400, SNMP/HTTP (Option)
2. Fan
3. Input Breaker
4. Inlet & Outlet (Terminal Block)
5. Maintenance Bypass Switch
6. External Battery Slot (Option)
7. Parallel port



# 1. Presentation

## ↳ Extended Battery Bank



## 2. Installation

### 2.1 Unpacking



You may find the "series number" labeled on both shipping box and UPS rear panel. If the UPS has a problem please send the number to your sales representative for tracking and troubleshooting.

The Star T3 Series UPS can be supplied in a varied number of boxes depending upon the model ordered. The number of boxes provided should be as follows:

<u>MODEL (Box 1)</u>	<u>TOTAL BOXES</u>
ST3060	1 Box
ST3100	1 Box

#### Star T3 Series 6/10kVA Tower

##### Box 1



User Manual



##### Shipping Box Includes:

1. UPS
2. User Manual
3. 25-pin Serial Communication cable (Option for parallel units only)
4. External Battery Cable for long runtime units (Option: 3-port for 6kVA, 5-port for 10kVA)

## 2. Installation

### 2.2 Installation

#### ↳ Standard



- ✎ Keep the UPS on a flat, stable surface with **50cm** space around it for proper ventilation.
- ✎ Installation and wiring must be following the local electric code and introduction below.
- ✎ Turn off the UPS and equipments before installation.

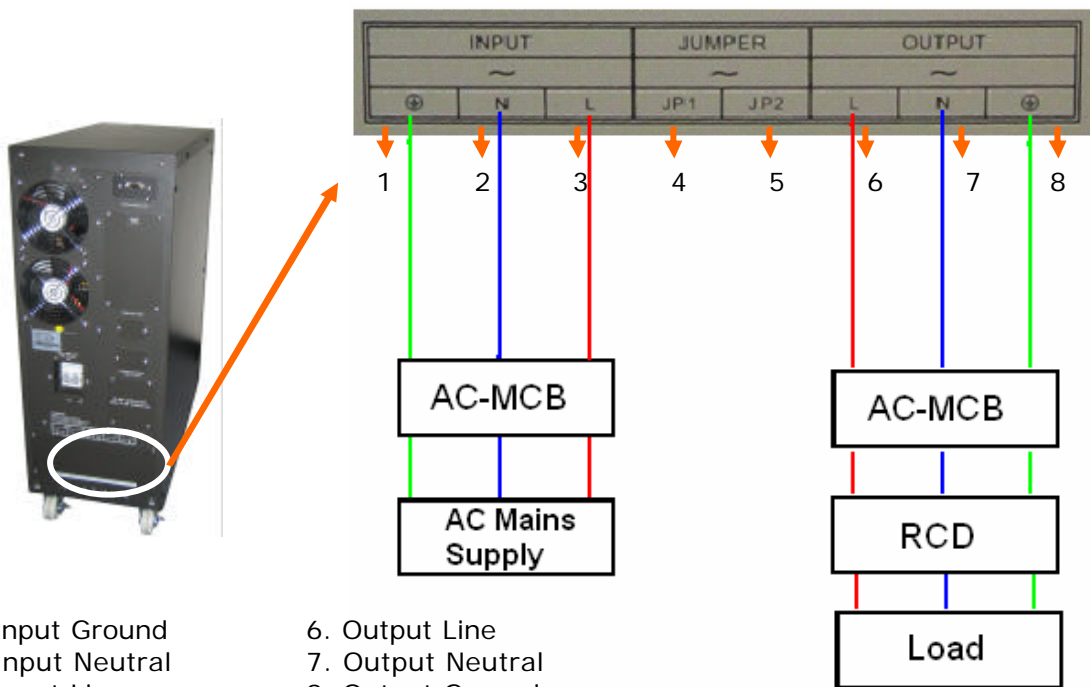

1. Input Ground
2. Input Neutral
3. Input Line
- 4 & 5. Connect JP1 and JP2 via 10AWG (6mm<sup>2</sup>) for **single** usage, disconnect JP1 and JP2 for **parallel** usage.
6. Output Line
7. Output Neutral
8. Output Ground

- (1) Remove the cover of the terminal block, please use the above table and diagram on the back panel for correctly cabling the UPS.
- (2) Ensure the earth/ground cable is correctly sized according to electrical regulations.
- (3) After making connections, double check the wiring is correct and wires are secure.
- (4) **\*IMPORTANT\*** - If an earth leakage protection device (RCD) is to be used on the installation, this must be installed between the output of the UPS and the distribution board. It must not be before the input of the UPS.
- (5) Ensure all load equipment is turned off before starting UPS. The load equipment must be started one by one to avoid inrush current.
- (6) **\*WARNING\*** - AC and DC voltages can still be present on the terminal blocks even with the mains supply disconnected. Always check with a multi-meter before handling cables or connections.



- ✎ Suggest the UL 1015 10AWG(6mm<sup>2</sup>) wire used in 6kVA for input and output wirings.
- ✎ Suggest the UL 1015 8AWG(10mm<sup>2</sup>) wire used in 10kVA for input and output wirings.
- ✎ Please allow the UPS to charge its batteries for 24 hours before turning it on. Your connected equipment will still receive power while the UPS is off. Backup time may be shortened if the UPS is not charged first.
- ✎ Please calculate the capacity of UPS to include start-up of currents of any necessary inductance loads such as monitor and printer, etc.

## 2. Installation

### ↳ External Battery

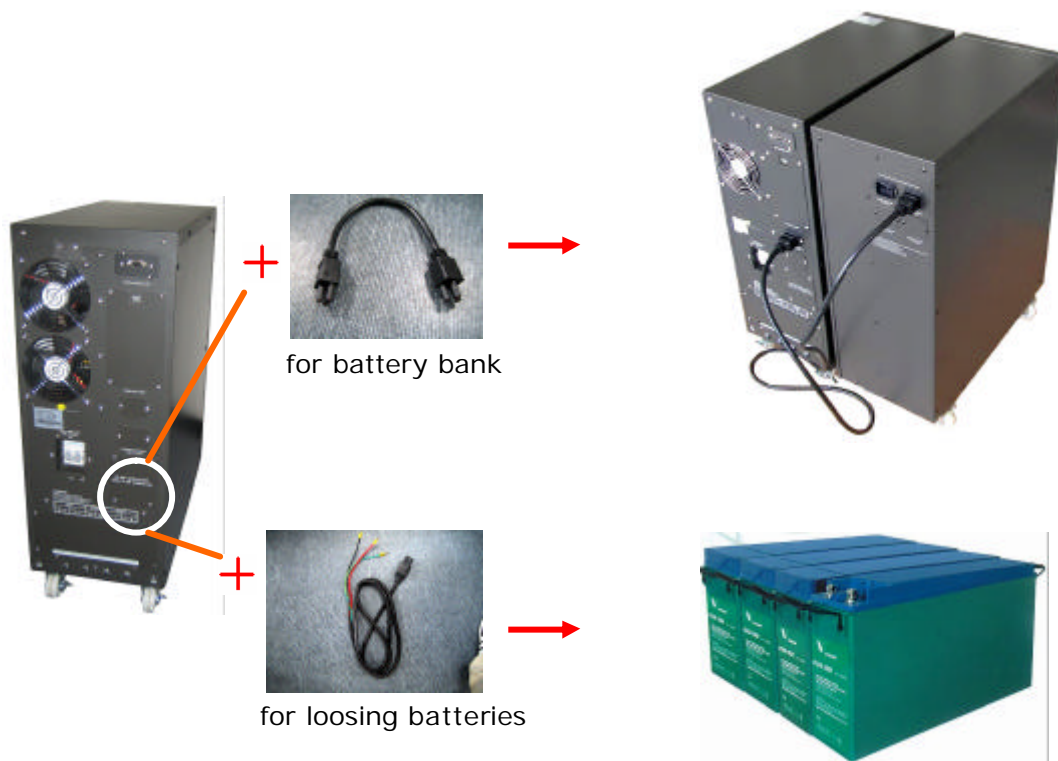

- (1) For the long runtime application, please make sure the battery voltage must be 240 VDC nominal.
- (2) Connect the external battery with the proper external battery cable as shown pictures above.
- (3) After making connections, double check the wiring is correct and wires are secure.

## 2. Installation

### 1 Parallel



- ✍ For parallel operation, JP1 & JP2 on the terminal block of each UPS should be disconnected
- ✍ Keep the UPS on a flat, stable surface with **50cm** space around it for proper ventilation.
- ✍ Installation and wiring must follow the local electrical regulations and instructions below.
- ✍ Turn off the UPS and equipments before installation.

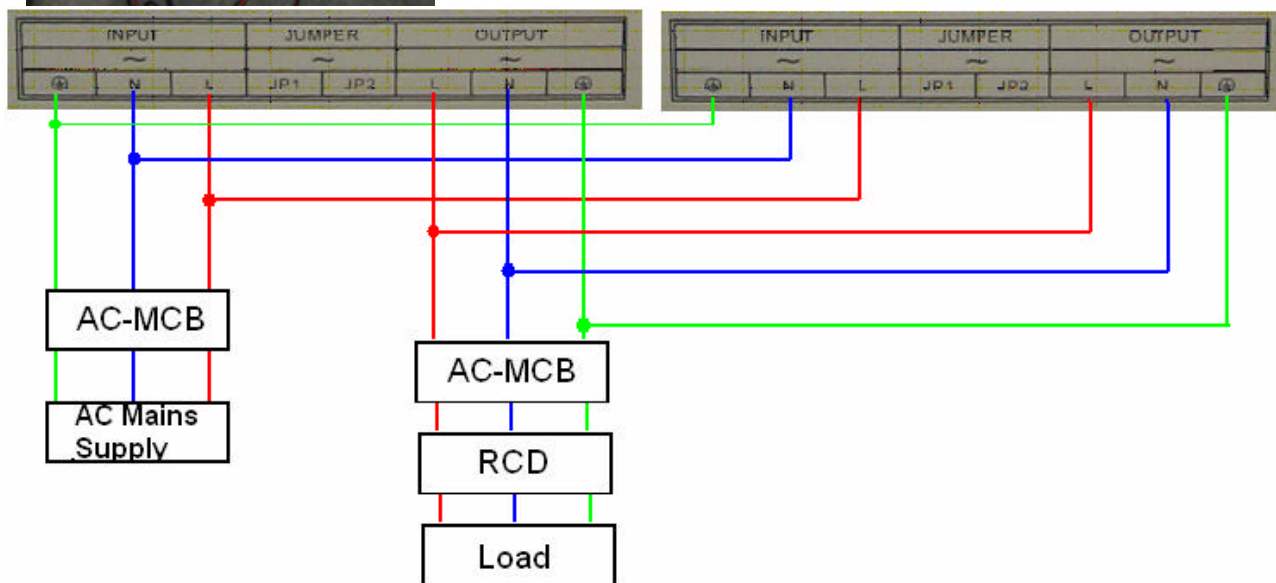

- (1) Remove covers from parallel slots on each UPS then use 3 meter 25-pin communication cable to connect UPS to each other.
- (2) Remove the cover of the terminal block, please use the above table and diagram on the back panel for correctly cabling the UPS.
- (3) Ensure the earth/ground cable is correctly sized according to electrical regulations.
- (4) After making connections, double check the wiring is correct and wires are secure.
- (5) **\*IMPORTANT\*** - If an earth leakage protection device (RCD) is to be used on the installation, this must be installed between the output of the UPS and the distribution board. It must not be before the input of the UPS.
- (6) Ensure all load equipment is turned off before starting UPS.
- (7) Start up each UPS one by one and make sure all UPS are working in normal mode.
- (8) Measure the voltage at JP1 & JP2 on each UPS. If the difference between them is greater than 1 VAC, please check the output relay and restart the UPS.
- (9) Please measure the JP2 points (one on each units) the voltage difference between these two units should be less than 5 VAC (2VAC generally). If the voltage more than 5 VAC, please check the 25-pin communication cable.
- (10) The load equipment must be started one by one to avoid inrush current.
- (11) **\*WARNING\*** -AC and DC voltages can still be present on the terminal blocks even with the mains supply disconnected. Always check with a multi-meter before handling cables or connections.

## 2. Installation

### 2.3 Connection to communication

#### 2.3.1 Standard

##### 1 RS-232

The communication interface (DB9 port) on the back of the UPS may be connected to a host computer with specific monitoring software installed. (Please contact sales representative for further information of monitor software)

The pins of the connector are as following:

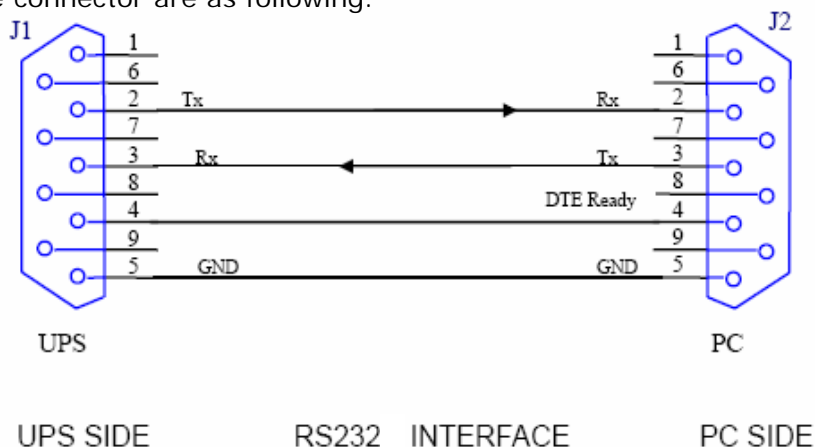

PIN #	PIN Definition (UPS)	PIN Definition (PC)
2	Transmitted data	Received data
3	Received data	Transmitted data
5	Signal Ground	Signal Ground

The RS-232 interface settings are as follows:

Baud Rate	2400 bps
Data Length	8 bits
Stop Bit	1 bit
Parity	None

## 2. Installation

### 2.3.2 Optional Interface Cards

A variety of interface cards can be installed into optional communication slot such as DB9 Dry Contact Card, USB Card, AS400 Card, and SNMP/HTTP Card.



#### 1 USB Card



#### DB9 Dry Contact Card



### Pin Definition of DB9 for NOVELL Interface

PIN # of DB9	Function explanation	I/O
1	UPS Fault	Output
3	GND	Input
4	Remote Shutdown UPS(+12VDC)(Work on Battery Mode)	Input
5	Input 12VDC	Input
6	Bypass Mode	Output
7	Low Battery	Output
8	Normal Mode, Battery Mode	Output
9	Utility Power Fault	Output

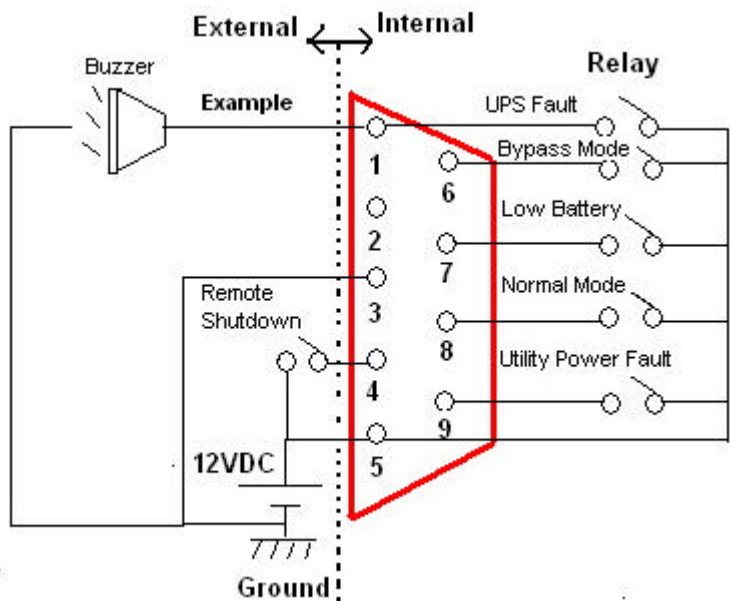

## 2. Installation

### ↳ AS400 Card



Please visit IBM'S website [www.ibm.com](http://www.ibm.com) for more information.

### ↳ SNMP/HTTP Agent



(External)



(Internal)

**NetAgent II** allows a user to obtain the status, and issue commands to the UPS. The communications protocol includes the MegaTec/ PPC/ SEC 2400 / 9600. Also it is possible to build in your own protocol. NetAgent II provides a simple and easy installation procedure. The user only needs to install the software from the NetAgent II CD on a Windows environment and configure the IP address.

All the other configurations could be accomplished in a Web browser. NetAgent II also provides shutdown programs for different operating systems. Shutdown commands can be sent for such events as power failure, low UPS battery condition, UPS overload, UPS overheating and scheduled shutdowns. All shutdown events are configurable by the user. The shutdown software provides an orderly shutdown to prevent the abnormal shut-off of clients or servers.

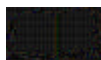

Please refer to the NetAgent II installation CD for more information.



### 3. Operation

#### 3.1 LCD and LED Display

##### 1 LCD

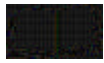

"Select-Down" Key: ▼ "Select-Up" Key: ▲

⚡ The welcome screen only shows for 10 seconds as UPS starts up, after that the "UPS Status" will show on the display.

⚡ The screen should go back to "UPS Status" if you do not push any buttons for 2 minutes.

Display 1 - Welcome screen

AEC Star T3 Series  
On-Line UPS

Display 2 - Input/Output Voltage  
and Frequency  
Identification

▼ | ▲  
Input: 220V 50Hz  
Output: 220V 50Hz

Display 3 - UPS Status

▼ | ▲  
AC: FAIL BATT: LOW  
NO Output

Display 4 - Real Input/Output  
Voltage and Frequency

▼ | ▲  
Input Voltage  
220 VAC

▼ | ▲  
Output Voltage  
220VAC

▼ | ▲  
Input Frequency  
50 Hz

▼ | ▲  
Output Frequency  
50 Hz

▼ | ▲

### 3. Operation

Display 5 – Battery Voltage/  
Capacity

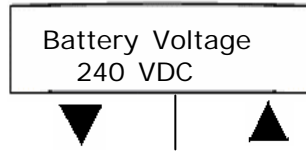

Display 6 – Output Power

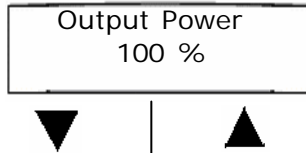

Display 7 – Inside Temperature



Display 8 – New Alarm

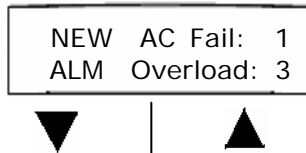

Display 9 – Old Alarm

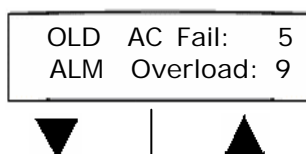

Display 10 – Bypass Voltage Setting

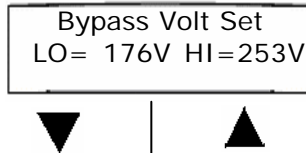

Display 11 – Output Voltage/  
Frequency Setting

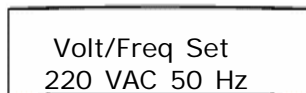

### 3. Operation

#### 1 LED

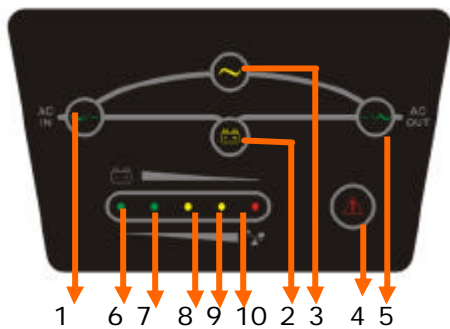

1. Line LED (green): This indicates the AC power is applied to the UPS input. If the LED blinks, it means the AC power source is out of tolerance.
2. Battery LED (yellow): This indicates the UPS is in Battery Mode.
3. Bypass LED (yellow): This indicates the UPS is in Bypass Mode.
4. Fault LED (red): This indicates the UPS is in fault condition because of UPS shutdown or over-temperature
5. Inverter LED (green): This indicates the inverter is working normally.

#### 6-10. Load & Battery Capacity LEDs:

- (a) No. 6 to 7 LED is green color, No. 8 to 9 is yellow and No.10 (used as warning LED for overload or battery low) is red.
- (b) These LEDs show the load (%) of the UPS if the AC input is available (in Normal Mode). LEDs light up to indicate the following information.

No. 6 LED: 0-25 %	No. 6 - 9 LEDs: 76-100 %
No. 6 - 7 LEDs: 26-50 %	No. 6 - 10 LEDs: Overload
No. 6 - 8 LEDs: 51-75 %	

- (c) In the Battery Mode, the LEDs indicate the capacity (%) of the batteries. LEDs light up to indicate the following information.

No. 10 LED: 0-25 % (battery low level)	
No. 9 - 10 LEDs: 26-50 %	No. 7 - 10 LEDs: 76-95 %
No. 8 - 10 LEDs: 51-75 %	No. 6 - 10 LEDs: 96-100 %

### 3. Operation

#### 3.2 Starting up/ Shutting down the UPS

##### **Starting up of the UPS**

- Step 1. Connect the UPS into an AC mains supply and the UPS will enter Bypass mode.
- Step 2. Press the "Select-down" & "Enter" buttons simultaneously to switch on UPS. The UPS will begin its start-up process. After entering the Normal Mode, the UPS is ready for operation.

##### **Shutting down the UPS**

Press the "Select-up" & "Select -down" buttons simultaneously for a few seconds. The UPS will Turn off.



**During shutdown, do not press any buttons. Pressing a button may cause the UPS to re-energize and deliver output power.**

##### **Battery Start-up of the UPS**

- Step 1: Unplug the UPS from any AC mains supply.
- Step 2: Press the "Select-down" & "Enter" buttons simultaneously to switch on UPS. The UPS will begin its start-up process. After entering the Battery Mode, the UPS is ready for operation.

### 3. Operation

#### 3.3 Operation Modes

##### **Normal Mode**

There are two main circuits when AC utility is normal: the AC circuit and the battery charging circuit. The AC output power comes from AC utility input and passes through AC/DC rectifier, DC/AC inverter and static switch to support power to load. The battery charging voltage comes from AC utility input and is converted by AC/DC charger to support battery-charging power.

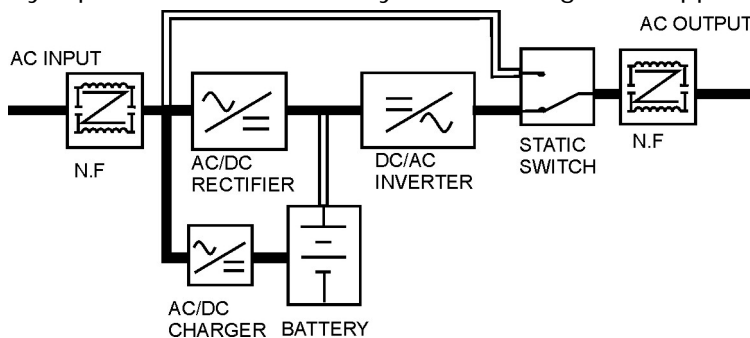

##### **Battery Mode**

The AC output comes from battery, passing through DC/AC inverter and static switch within the battery backup time.

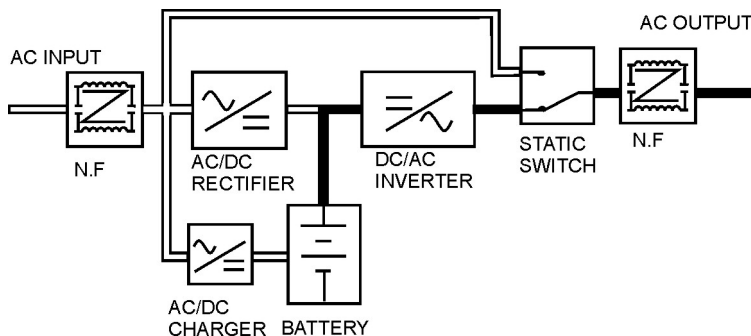

##### **Bypass Mode**

Under the following conditions, the bypass will be enabled:

1. Overload
2. Inverter failure
3. Over-temperature

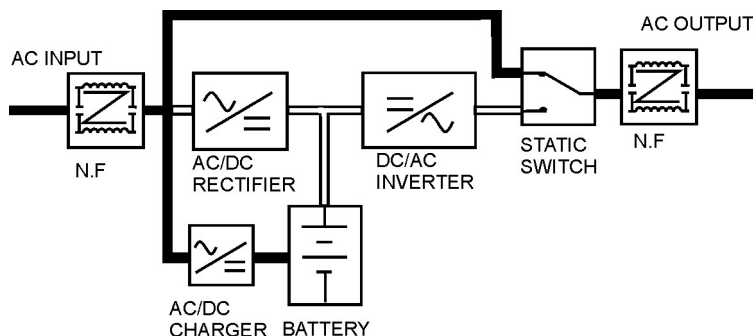

### 3. Operation

#### 3.4 Configuration Settings

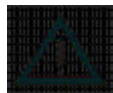

**UPS must be working on Bypass Mode in advance for any setting, because the setting function can not be available on Normal Mode and Battery Mode.**

##### ↓ Output Voltage / Frequency

Step 1. In this screen, press the "Enter" key to enter the following steps for output voltage / frequency adjustment.

**Display 11** – Output Voltage/  
Frequency Setting

Volt/Freq Set  
220 VAC 50 Hz

Step 2. The cursor ( ? ) will pop up to indicate the output voltage and frequency newly selected.

**Display 11** – Output Voltage/  
Frequency Setting

Volt/Freq Set  
\_220 VAC 50 Hz

**Display 11** – Output Voltage/  
Frequency Setting

Volt/Freq Set  
220 VAC \_50 Hz

Step 3. Use the "Select-Up" or "Select-Down" keys to adjust the output voltage (220V, 230V, and 240V ). Press the "Enter" key to confirm the voltage and then the cursor will move to frequency selection. The output frequency (50Hz, 60Hz, 50HzP, 60HzP) can be adjusted by the same key operation.

Step 4. Once the correct voltage is selected, press the "Enter" key again to save the selection.

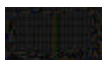

**There is no output on Bypass Mode if frequency is setting on 50Hz/60Hz, on the other hand, there is output on Bypass Mode if frequency is setting on 50HzP/60HzP.**

**Display 11** – Output Voltage/  
Frequency Setting

Volt/Freq Set  
Save? \_NO

### 3. Operation

#### 1 Bypass Voltage

Step 1. To protect the load, the function of bypass auto-transfer is activated only when the AC main voltage is within the range of LO (low) and HI (high). In this screen, press the "Enter" key to confirm the following steps for LO/HI voltage setting.

**Display 10** – Bypass Voltage Setting 

Bypass Volt Set LO= 176V HI=253V
-------------------------------------

Step 2. The cursor ( ? ) will pop up to indicate the item newly selected. Press the "Enter" key to get the item of LO or HI range the user want to adjust.

**Display 10** – Bypass Voltage Setting 

Bypass Volt Set _LO= 176V HI=253V
--------------------------------------

**Display 10** – Bypass Voltage Setting 

Bypass Volt Set LO= 176V HI=253V
-------------------------------------

Step 3. Use the "Select-Up" or "Select-Down" keys to adjust the voltage (changing 1V by every press). LO (low range): 176V +/- 20V, HI (high range): 253V +/- 20V.

Step 4. Once the value is confirmed, press the "Enter" key again to save the data.

**Display 10** – Bypass Voltage Setting 

Bypass Volt Set Save? _ NO
-------------------------------

## 4. Maintenance

### 4.1 General Maintenance

The Star T3 Series UPS requires very simple maintenance. The batteries are sealed, valve-regulated, maintenance-free and enclosed in a fire-retardant pack. The batteries should be kept charged to maintain their designed lifetime. When utility power is supplied to the UPS, it will continuously charge the batteries.

#### ↓ Environment

- ⊗ For the best preventive maintenance, keep the area around the UPS clean and dust-free.
- ⊗ Please keep the exhaust holes of UPS unobstructed.
- ⊗ Operate the UPS in an indoor environment with an ambient temperature range of 32°F to +104°F (0°C to +40°C).
- ⊗ Keep the UPS on a flat, stable surface with **50cm** space around it for proper ventilation.
- ⊗ Do not place the unit near a heat source and avoid placing the unit in direct sunlight.
- ⊗ Do not place the unit near water or excessive moisture.

#### ↓ Storing the UPS and Battery

When storing the UPS for any length of time, it is recommended to plug in the UPS for at least 24 hours every four to six months to ensure full battery recharge.

#### ↓ Replace the Battery

It is suggested that the battery pack be replaced every two years to ensure that the UPS provides full backup capacity during a blackout. Batteries should be checked every two to three months. If the batteries need replacing, please contact your sales representative to order a new battery.



## 4. Maintenance

### 4.2 Replacing the New Battery

This UPS contains potentially hazardous voltages. Do not open the UPS. There are no user-serviceable parts inside.



- ⚡ When replacing the battery, use the same number and voltage(V)/capacity(Ah).
- ⚡ Avoid harm to the environment: proper disposal or recycling of the batteries is required. Refer to local regulations for disposal requirements.
- ⚡ NEVER dispose of battery in a fire. They may explode.
- ⚡ Do not open or damage the battery. The contents (electrolyte) may be extremely toxic. If exposed to electrolyte, then wash immediately with plenty of water.
- ⚡ Avoid charging in a sealed container.
- ⚡ Never short circuit the battery. When working with batteries, remove watches, rings and other metal objects. Only use insulated tools.
- ⚡ The following precautions should be observed when working on batteries:
  - ? Remove watches, rings, and other metal objects.
  - ? Use tools with insulated handles.
- ⚡ Make sure that there is no voltage before touching the batteries.

### 4.3 Testing the New Battery

Start up the UPS with load added. Press the "Select-up" & "Enter" buttons (for LCD version) or the "Select-down" & "Enter" buttons (for LED version) for three seconds to activate the self-test. If the UPS switches back to Normal Mode after 10 seconds, then the batteries are good. If it does not, then please replace the battery or contact your sales representative for assistance.

### 4.4 Recycling the Used Battery

Do not discard the UPS and batteries with normal household/industrial waste. Contact your local recycling or hazardous waste center for information on proper disposal of used battery pack and batteries.



- Consider all warnings, cautions, and notes before replacing batteries. Batteries can present a risk of electrical shock and high short circuit current. The following precautions should be observed when working on batteries:**
- ⚡ **Remove watches, rings, and other metal objects.**
  - ⚡ **Use tools with insulated handles.**
  - ⚡ **Do not lay tools or metal parts on top of batteries.**
  - ⚡ **Do not attempt to alter any battery wiring or connectors. Attempting to alter wiring can cause injury.**
  - ⚡ **Do not dispose of batteries in a fire. The batteries may explode. Refer to your local codes for disposal requirements.**
  - ⚡ **Do not open or damage the battery or batteries. Released electrolyte is harmful to the skin and eyes and it is toxic.**

## 4. Maintenance

### 4.5 Maintenance Bypass



⚠ Bypass switch not to be operated if the UPS is in 'Battery Mode'!  
⚠ IF THE FOLLOWING PROCEDURE IS NOT FOLLOWED EXACTLY THE LOAD ON THE OUTPUT OF THE UPS MAY BE INTERRUPTED AND THE UPS MAY BE DAMAGED.

#### ↳ Switch to bypass





1. In case of performing service or maintenance on the UPS or bypass the LOAD from the UPS, a Maintenance Bypass Switch can be operated located at the back of the UPS.
2. Turn the UPS into internal bypass mode by pressing the Up '?' and Down '?' arrow keys together.
3. Ensure the UPS has gone into 'Bypass Mode' by checking from the display.
4. Unscrew the cover to reveal the Maintenance Bypass Switch.
5. Rotate the switch to 'Bypass'

#### ↳ Return from bypass to normal mode



1. Ensure the UPS is in 'Bypass Mode' referring step 1 of section 3.2 Start UP of the UPS, and check from the display. If the UPS is in 'Normal Mode' switch it to 'Bypass Mode' by pressing the Up '?' and Down '?' arrow keys together.
2. Rotate the Maintenance Bypass Switch to 'UPS' position.
3. Reattach the Maintenance Bypass Switch cover. (Note: the inverter will not start with this cover off the unit.)
4. Restart the Inverter (UPS) referring step 2 of section 3.2 Start UP of the UPS.

## 5. Troubleshooting

### 1 LCD

LCD & LED Status / Audible Alarms	Possible Cause	Action
<p>AC: OK      BATT: OK</p> <p>TEMP Fail</p> <p>Fault      Warning      Normal</p>  <p>✘ UPS in Bypass Mode. ✘ The alarm beeps continuously.</p>	<ol style="list-style-type: none"> <li>1. Fan fail.</li> <li>2. Temperature is higher than allowed operation temperature.</li> </ol>	<ol style="list-style-type: none"> <li>1. Replace the fan.</li> <li>2. Reduce ambient temperature or O/P load.</li> </ol>
<p>AC: OK      BATT: OK</p> <p>Inverter Fail</p> <p>Fault      Warning      Normal</p>  <p>✘ UPS in Bypass Mode. ✘ Fault LED lights up and the beeps continuously.</p>	<ol style="list-style-type: none"> <li>1. Inverter circuit failed</li> <li>2. Output short.</li> </ol>	<ol style="list-style-type: none"> <li>1. Please contact with sale representative.</li> <li>2. Remove short circuit condition, restart the UPS.</li> </ol>
<p>AC: OK      BATT: OK</p> <p>DC_BUS Fail</p> <p>Fault      Warning      Normal</p>  <p>✘ UPS in Bypass Mode. ✘ The alarm beeps continuously.</p>	<ol style="list-style-type: none"> <li>1. Power Board failed.</li> </ol>	<ol style="list-style-type: none"> <li>1. Restart the UPS first. If the UPS can not work normally, please contact with sale representative.</li> </ol>
<p>AC: OK      BATT: LOW</p> <p>Normal Mode</p> <p>Fault      Warning      Normal</p>  <p>✘ UPS in Normal Mode, but battery capacity is low. ✘ The alarm beeps once every second for battery low.</p>	<ol style="list-style-type: none"> <li>1. Charger may break down.</li> </ol>	<ol style="list-style-type: none"> <li>1. Please replace charger board.</li> </ol>
<p>Output Power</p> <p>105 %</p> <p>Fault      Warning      Normal</p>  <p>✘ AC utility power is normal but UPS is overloaded up to 105%~130%. ✘ Warning LED lights up and the alarm beeps per 0.5 second.</p>	<ol style="list-style-type: none"> <li>1. Overload.</li> </ol>	<ol style="list-style-type: none"> <li>1. Please reduce the load less than &lt;100%.</li> </ol>

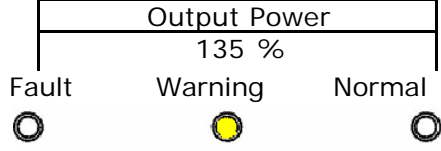
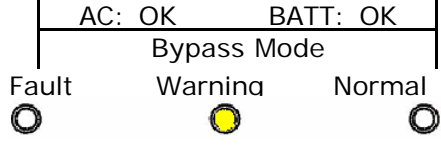
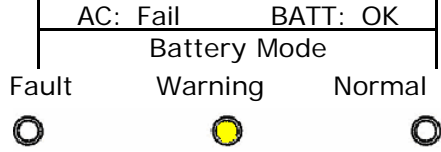
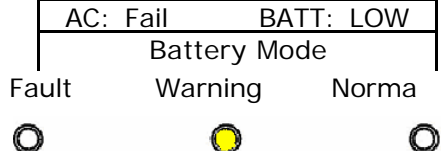
## 5. Troubleshooting

LCD & LED Status / Audible Alarms	Possible Cause	Action
 <p>Output Power 135 %</p> <p>Fault      Warning      Normal</p> <ul style="list-style-type: none"> <li>✍ AC utility power is normal but UPS is overloaded up to 130%~150%.</li> <li>✍ Warning LED does not fade out and the alarm beeps per 0.5 second.</li> </ul>	<p>1. Overload.</p>	<p>1. Please reduce the load less than &lt;100%.</p>
 <p>AC: OK      BATT: OK</p> <p>Bypass Mode</p> <p>Fault      Warning      Normal</p> <ul style="list-style-type: none"> <li>✍ UPS in Bypass Mode.</li> <li>✍ Warning LED does not fade out and the alarm beeps per 0.5 second.</li> </ul>	<p>1. Overload.</p>	<p>1. Please reduce the load less than 100%.</p>
 <p>AC: Fail      BATT: OK</p> <p>Battery Mode</p> <p>Fault      Warning      Normal</p> <ul style="list-style-type: none"> <li>✍ UPS in Battery Mode.</li> <li>✍ Alarm beeps every 4 seconds.</li> </ul>	<p>1. AC utility power fail.</p> <p>2. Input cable broken or disconnect with UPS.</p>	<p>1. If AC utility power fails, reduce the load in order to extend backup time.</p> <p>2. If it is not power failure, please check the rated input or connected power line.</p>
 <p>AC: Fail      BATT: LOW</p> <p>Battery Mode</p> <p>Fault      Warning      Norma</p> <ul style="list-style-type: none"> <li>✍ UPS in Battery Mode.</li> <li>✍ Alarm beeps per 1 second.</li> </ul>	<p>1. AC utility power fail.</p> <p>2. Battery power is discharging deeply.</p>	<p>1. UPS will shut down automatically. Please save data soon.</p>
 <p>Fault      Warning      Normal</p> <ul style="list-style-type: none"> <li>✍ UPS completely shut down.</li> </ul>	<p>1. AC utility power fail.</p> <p>2. The UPS has already run out of battery.</p>	<p>1. UPS will restart up when AC utility power is restored. If AC utility power failure is more than 6 hours, please charge the battery for 24 hours to ensure the battery fully charged.</p>

## 5. Troubleshooting

### 1 LED

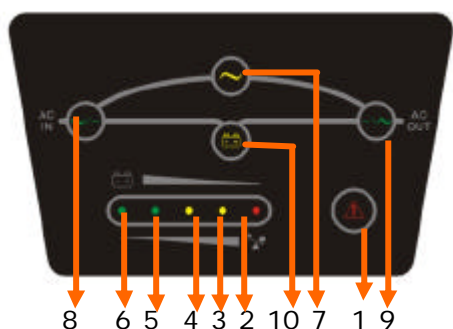

LED Status / Audible Alarms	Possible Cause	Action
The #1 Fault LED and the #6 LED are turned on, the alarm beeps continuously.	The UPS transfers to fault mode due to internal overheat.	Make sure the UPS is not overloaded; the air vents are not blocked and the ambient temperature is not too high. Wait for 10 minutes for the UPS to cool down before turning on again. If failed, please contact the Sales Representatives.
The #1 Fault LED and the #2 and #5 LED are turned on, and the alarm beeps continuously.	The UPS output is short circuited.	Remove all the loads. Turn off the UPS. Ensure that the load is not failed or the UPS has no internal faults before turning it on again. If failed, please contact the Sales Representatives.
The #1 Fault LED and the #4 LED are turned on, the UPS beeps continuously.	The UPS transfers to fault mode due to its internal fault.	Please contact the Sales Representatives.
The #1 Fault LED and the #5 LED are turned on, the UPS beeps continuously.	The UPS transfers to fault mode due to its internal fault.	Please contact the Sales Representatives.
The utility power LED flashes.	The voltage or frequency of the utility power is out of the input range of the UPS.	The UPS is running in battery mode. To save your data and close the application program. Make sure the utility power is within the input voltage or frequency range permitted by the UPS.
The #1 Fault LED and the #2 LED are turned on, the UPS beeps continuously.	The UPS is overloaded or the load equipment is faulty.	Check the loads and remove all no-critical equipment. Recalculate the load power and reduce the number of loads connected to the UPS. Check that the loads are not failed.
The #1 Fault LED is turned on, and the battery LED is flashed, the UPS beeps every second.	The charger of the UPS is defective.	Please contact the Sales Representatives.
Battery LED flashes	Battery low or battery not connected.	Check the battery. If the battery is damaged, replace the battery immediately and ensure that the battery breaker is in "ON" position.
The utility power is normal, but the UPS can not turn in line mode	Maintain switch loose	Please contact the Sales Representatives.

## 5. Troubleshooting

LED Status / Audible Alarms	Possible Cause	Action
Battery discharging time diminishes	Battery not yet been fully charged.	Keep UPS connected to utility power continuously for more than 10 hours to recharge the batteries again.
	UPS overloaded.	Check the loads and remove the non-critical equipment.
	Battery aged.	Replace the batteries. Please contact the distributor to obtain the parts and replacement service.
The UPS cannot power on after pressing the ON button	The "ON" button is pressed too briefly.	Press the "ON" button for more than 1 second.
	The UPS is not connected to the battery or the battery pack voltage is too low.	Check the battery or recharge the battery.
	UPS fault.	Please contact the Sales Representatives.

## 5. Troubleshooting

### The form of LED Display

No.	Operating status		LED display										Alarm warning
			1 #	2 #	3 #	4 #	5 #	6 #	7 #	8 #	9 #	10 #	
1	Normal Mode	0~35% Load capacity						?		?	?		none
2		36%~55% Load capacity					?	?		?	?		none
3		56%~75% Load capacity				?	?	?		?	?		none
4		76%~95% Load capacity			?	?	?	?		?	?		none
5		96%~105% Load capacity		?	?	?	?	?		?	?		none
6	Battery Mode	0~20% Battery capacity		?							?	?	Beep once every sec
7		21%~40% Battery capacity		?	?						?	?	Beep once every 4 sec
8		41%~60% Battery capacity		?	?	?					?	?	Beep once every 4 sec
9		61%~80% Battery capacity		?	?	?	?				?	?	Beep once every 4 sec
10		81%~100% Battery capacity		?	?	?	?	?			?	?	Beep once every 4 sec
11	Bypass mode			?	?	?	?	?	?	?			Beep once every 2 min.
12	overloaded in normal mode and UPS still in INV mode		?	?	?	?	?	?		?	?		Beep twice every sec.
13	overloaded in normal mode and UPS in bypass mode		?	?	?	?	?	?	?	?			Beep twice every sec.
14	Utility power abnormal			?	?	?	?	?	?	?	?	?	?
15	Overloaded in battery mode, Early-warning			?	?	?	?	?		?	?	?	Beep twice every sec.
16	Overloaded in battery mode, Cut off the output		?	?						?			Continuously beep
17	Over temperature		?					?	?	?			Continuously beep
18	Inv abnormal		?				?		?	?			Continuously beep
19	Output short circuited		?	?			?			?			Continuously beep
20	BUS voltage abnormal		?			?			?	?			Continuously beep
21	Charger and battery failed		?						?	?	?	?	Beep once every sec
22	BAT SCR failed		?		?			?	?	?			Continuously beep
23	Fan abnormal		?	?				?	?	?	?	?	Beep once every sec
24	INV RLY failed		?			?		?	?	?			Continuously beep
25	Communication abnormal		?		?	?			?	?			Continuously beep
26	Parallel abnormal		?	?	?			?		?			Continuously beep

?: Solid ON ? : Flash ? : LED display and alarm warning are dependent on other conditions.

## 6. Appendix

### 6.1 Specifications

#### ↓ General Specification

<b>Specifications</b>		
<b>Model No.</b>	<b>ST3060</b>	<b>ST3100</b>
Topology	True On - Line , Double Conversion	
On- battery Output Waveform	Pure Sine Wave	
Number of Phase	Single ( 1 F 2W + G )	
<b>Input</b>		
Maximum Capacity ( VA / W )	6000 VA / 4200 W	10000 VA / 7000 W
Nominal Input Voltage	230 VAC	
Input Voltage Regulation	170~285 VAC Single Phase w/ Ground	
Nominal Input Frequency	50/60 ± 4 Hz	
Input PFC	? 0.98	
Input Short Protection	Circuit Breaker	
<b>Output</b>		
Nominal Output Voltage	220 / 230 / 240 VAC nominal	
Output Voltage Regulation	+ / - 1 %	
Output T.H.D	? 2% THD (Linear Load) ? 6% THD (Non-Linear Load)	
High Efficiency Mode ( AC to AC )	> 88 %	
High Efficiency Mode ( DC to AC )	> 88 %	
Crest Factor	3 : 1	
Start on Battery	Yes	
Output Frequency	50 Hz + / - 0.5 Hz	
Overload (Normal Mode)	10min@105~130% , 1sec@ >130% then shutdown UPS 1min later	
Overload (Battery Mode)	10sec @>150%	
<b>Battery</b>		
Typical Backup Time ( Full load )	8 minutes	5 minutes
Battery Type	Sealed Lead-Acid maintenance-free 12VDC/7AH per cell	Sealed Lead-Acid maintenance-free 12VDC/9AH per cell
Numbers of Batteries	20 cells	
Recharge Time to 90%	7 hours	8 hours
<b>Advance Warning Diagnostics</b>		
Front Panel Indication - LCD	UPS Status, I/P Voltage & Frequency, O/P Voltage & Frequency, Battery Voltage, Battery Capacity, Loading %, Temperature, History Alarm.	
Front Panel Indication - LED	Normal ( Green ), Warning ( Yellow ), Fault ( Red )	
Audible Alarms	Battery Mode, Low Battery, Overload, Fault	
<b>Communication Interface</b>		
Communication port	RS232 (Standard); DB9 or USB or AS400 or SNMP / HTTP(Optional)	
SNMP Manageable	Yes	
<b>Environmental</b>		
Operation Temperature	0-40?	
Storage Temperature	- 15 to 50 ?	
Relative Humidity	20% to 90 % Non-Condensing	
Audible Noise ( at 1 meter from surface of unit )	< 55 dBA @ 1 meter	
<b>Mechanical</b>		
Dimensions ( W x H x D mm )	260 x 717 x 570	
Weight ( Net weight with Battery ) ( kgs )	90	93



## 6. Appendix

### 1 Battery Run Time

RUN TIME CHART in Minutes									
Output load	2 kVA (1.4 kW)	3 kVA (2.1 kW)	4 kVA (2.8 kW)	5 kVA (3.5 kW)	6 kVA (4.2 kW)	7 kVA (4.9 kW)	8 kVA (5.6 kW)	9 kVA (6.3 kW)	10 kVA (7 kW)
UPS Model									
<b>ST3060</b>	38	22	15	10	8				
+ 1 EB (40pcs)	158	95	66	49	38				
+ 2 EB (80pcs)	297	180	126	95	75				
+ 3 EB (120pcs)	446	273	192	145	116				
<b>ST3100</b>	54	31	21	15	12	9	7	6	5
+ 1 EB (40pcs)	216	131	91	68	54	44	37	31	27
+ 2 EB (80pcs)	402	246	172	131	104	85	72	62	54
+ 3 EB (120pcs)	602	370	261	198	158	131	110	95	83

 EB: External Battery Bank  
 For 6kVA, using 7Ah/12VDC battery  
 For 10kVA, using 9Ah/12VDC battery  
 Indicates time not calculated, contact sales representative for details.

## 6. Appendix

### 6.2 Contact Information

#### Asia

##### **Allis Electric Co., Ltd.**

12th F1., No.19-11, San-Chung Road, Nan Kang District,  
Taipei 115, Taiwan R.O.C.

Tel: 886-2-2655-3456 Fax: 886-2-2655-2286~7

E-mail: sales@allis.com.tw <http://www.allis.com.tw>

##### **Sheen Asia Electronics Co., Ltd.**

2F, Building A2, Beiwei Industrial Area, GETDD, Guangzhou,  
People's Republic of China, 510730

Tel: +86-20-8222 1370/1 Fax: +86-20-8222-1419

E-mail: sales@sheenasia.com <http://www.sheenasia.com>

#### North America

##### **IMP Enterprises, inc.**

18218 East McDermott, Suite E, Irvine, California 92614, U.S.A

Tel: +1-949-477-9198 Fax: +1-949-477-9195

E-mail: sales@impenterprises.com <http://www.impenterprises.com>

#### Europe

##### **AEC SpA**

Via Vesuvio 1 I-20054 NOVA MILANESE MI, Italy

Tel: +39-0362364535 Fax: +39-02-700-427499

+39 0362366059

E-mail: sales@aeceuro.com <http://www.aeceuro.com>

##### **AEC Power Control Ltd.**

Systems House, Eckington Business Park, Rotherside Road,  
Derbyshire, S21 4HL.

Tel: +44 (0)1246 439861 Fax: +44 (0)1246 431444

E-mail: info@aeceuro.co.uk <http://www.aeceuro.co.uk>