

Chapter 4 Part B:





Fuel and exhaust systems -

K-Jetronic fuel injection - 8 valve engines

Contents

| | | | |
|--|----|---|----|
| Accelerator cable - removal, refitting and adjustment | 8 | Fuel lift pump - testing, removal and refitting | 18 |
| Air cleaner element - renewal | 3 | Fuel metering distributor - removal and refitting | 15 |
| Airflow meter - removal and refitting | 16 | Fuel pump - removal and refitting | 19 |
| Airflow sensor plate and control plunger - testing | 14 | Fuel tank and associated components - removal and refitting | 22 |
| Auxiliary air valve - testing | 10 | General information and precautions | 1 |
| Catalytic converters - general information and precautions | 2 | Idle mixture - adjustment | 7 |
| Cold acceleration enrichment system - testing | 12 | Idle speed - adjustment | 4 |
| Cold start valve and thermostime switch - testing | 9 | Idle speed boost (air conditioned models) - testing and idle speed adjustment | 6 |
| Exhaust manifold - removal and refitting | 24 | Increased idling speed valve (air conditioned models) - testing | 5 |
| Exhaust system - inspection, removal and refitting | 25 | Inlet manifold - removal and refitting | 23 |
| Fuel accumulator - removal and refitting | 21 | Pressure relief valve - removal, servicing and refitting | 17 |
| Fuel filter - removal and refitting | 20 | Warm-up valve - testing | 11 |
| Fuel injectors - removal, testing and refitting | 13 | | |

Degrees of difficulty

| | | | | |
|---|--|--|---|--|
| Easy , suitable for novice with little experience  | Fairly easy , suitable for beginner with some experience  | Fairly difficult , suitable for competent DIY mechanic  | Difficult , suitable for experienced DIY mechanic  | Very difficult , suitable for expert DIY or professional  |
|---|--|--|---|--|

4B

Specifications

Air cleaner

| | |
|---------------------------------|-----------------------------------|
| Type | Automatic air temperature control |
| Element type | Renewable paper element |
| Application: | |
| 1.8 litre Golf | Champion U506 |
| 1.8 litre Jetta | Champion U502 |
| 1.8 litre GTi (engine code RP) | Champion U572 |

Fuel filter

| | |
|---------------------------------|-----------------|
| 1.8 litre GTi (engine code RP) | Champion L206 |
| All other models | Champion L204 * |

* *New copper washers must be used and these are not supplied with the filter*

Injection system

| | |
|------------------------|---|
| Type | K-Jetronic, continuous injection system (CIS) |
| Application | 1.8 litre (code EV) engine |
| System pressure: | |
| Pre March 1986 | 4.7 to 5.4 bar |
| From March 1986 | 5.2 to 5.9 bar |
| Idle speed: | |
| Pre Sept. 1984 | 900 to 1000 rpm |
| From Sept. 1984 | 800 to 1000 rpm |
| Air conditioned models | 850 to 1000 rpm |
| CO content % | 0.5 to 1.5 |

Torque wrench settings

| | Nm | lbf ft |
|--|----|--------|
| Injector insert | 20 | 15 |
| Injector line to injector | 25 | 18 |
| Injector line to fuel metering distributor | 10 | 7 |
| Thermo-time switch | 30 | 22 |
| System pressure relief valve | 20 | 15 |
| Cold start valve | 10 | 7 |
| Throttle valve housing to manifold | 20 | 15 |
| Inlet manifold | 25 | 18 |
| Fuel filter clamp | 10 | 7 |
| Union bolt at filter (from fuel accumulator) | 25 | 18 |
| Union nut at accumulator (to filter) | 20 | 15 |
| Union bolt at filter (to metering distributor) | 20 | 15 |
| Fuel pump reservoir mounting | 10 | 7 |
| Fuel pump non-return valve | 20 | 15 |
| Fuel pump damper unit | 20 | 15 |
| Inlet manifold nuts/bolts | 20 | 15 |
| Exhaust manifold | 25 | 18 |
| Exhaust heat shield | 10 | 7 |
| Exhaust pipe clamp bolts | 40 | 30 |

1 General information and precautions

General information

The principle of the K-Jetronic continuous injection system is very simple and there are no specialised electronic components. There is an electrically driven fuel pump and electrical sensors and switches but these are no different from those in general use on vehicles (see illustration).

The following paragraphs describe the

system and its various elements. Later Sections describe tests which can be carried out to ascertain whether a particular unit is functioning correctly. Repairs are not generally possible.

The system measures the amount of air entering the engine and determines the amount of fuel which needs to be mixed with the air to give the correct combustion mixture for the particular conditions of engine operation. Fuel is sprayed continuously by an injection nozzle to the inlet port of each cylinder. This fuel/air mixture is drawn into the cylinder when the inlet valves open.

Airflow meter

The airflow meter measures the volume of air entering the engine and comprises an air funnel with a sensor plate mounted on a lever which is supported at its fulcrum. The weight of the airflow sensor plate and its lever are balanced by a counterweight and the upward force on the sensor plate is opposed by a plunger. The plunger, which moves up and down as a result of the variations in air flow, is surrounded by a sleeve having vertical slots in it. The vertical movement of the plunger uncovers a greater or lesser length of the slots, which meters fuel to the injection valves.

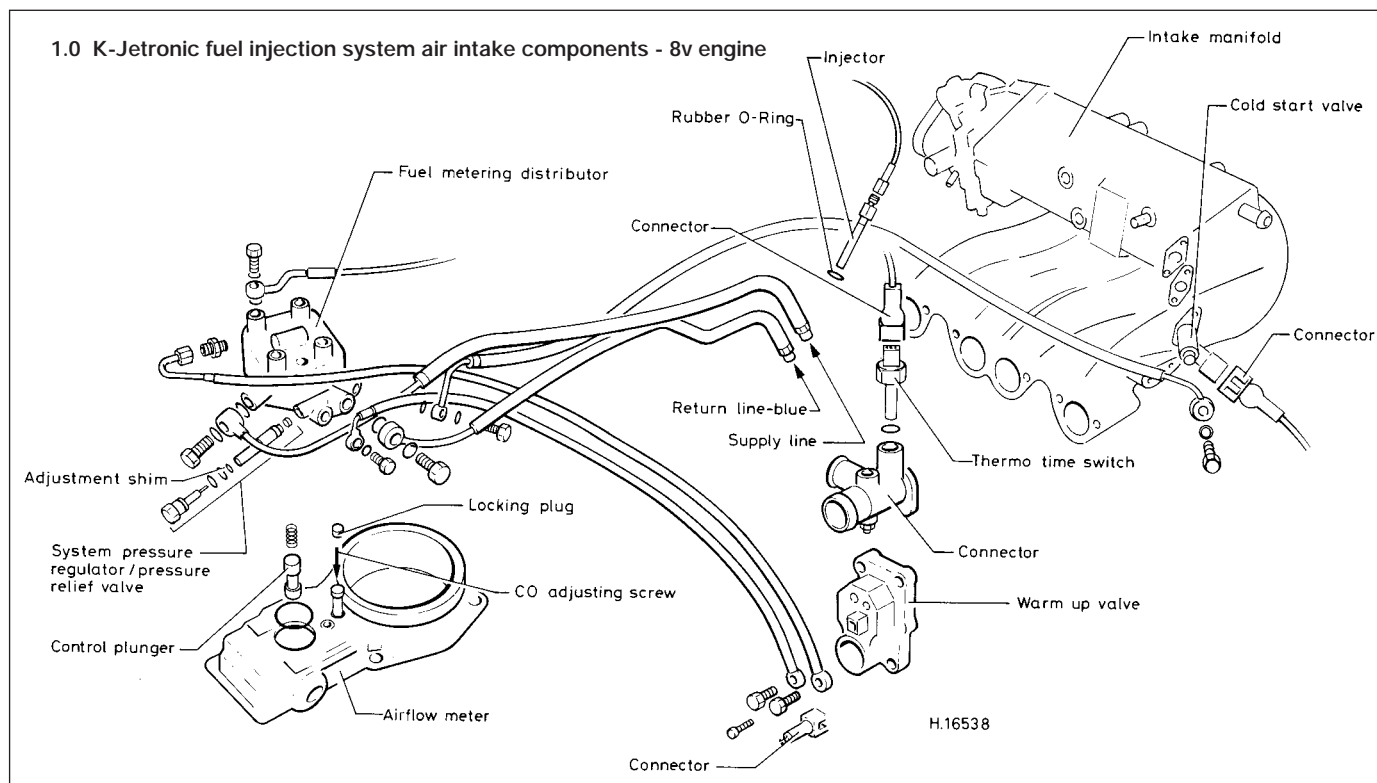

Fuel supply

The fuel pump operates continuously while the engine is running, excess fuel being returned to the fuel tank. The pump is operated when the ignition switch is in the START position. Once the starter is released, a switch which is connected to the air plate, prevents the pump from operating unless the engine is running.

The fuel line to the fuel supply valve incorporates a filter and also a fuel accumulator. The function of the accumulator is to maintain pressure in the fuel system after the engine has been switched off and so give good hot restarting.

Associated with the accumulator is a pressure regulator which is an integral part of the fuel metering device. When the engine is switched off, the pressure regulator lets the pressure to the injection valves fall rapidly to cut off the fuel flow through them and so prevent the engine from "dieseling" or "running on". The valve closes at just below the opening pressure of the injector valves and this pressure is then maintained by the accumulator.

Fuel distributor

The fuel distributor is mounted on the air metering device and is controlled by the vertical movement of the airflow sensor plate. It comprises a spool valve which moves vertically in a sleeve, the sleeve having as many vertical slots around its circumference as there are cylinders on the engine.

The spool valve is adjusted to hydraulic pressure on the upper end and this balances the pressure on the air plate which is applied to the bottom of the valve by a plunger. As the spool valve rises and falls, it uncovers a greater or lesser length of metering slot and so controls the volume of fuel fed to each injector.

Each metering slot has a differential pressure valve, which ensures that the difference in pressure between the two sides of the slot is always the same. Because the drop in pressure across the metering slot is unaffected by the length of slot exposed, the amount of fuel flowing depends only on the exposed area of the slots.

Cold start valve

The cold start valve is mounted in the inlet manifold and sprays additional fuel into the manifold during cold starting. The valve is solenoid operated and is controlled by a thermotime switch in the engine cooling system. The thermotime switch is actuated for a period which depends upon coolant temperature, the period decreasing with rise in coolant temperature. If the coolant temperature is high enough for the engine not to need additional fuel for starting, the switch does not operate.

Warm-up regulator (valve)

While warming up, the engine needs a richer mixture to compensate for fuel which

condenses on the cold walls of the inlet manifold and cylinder walls. It also needs more fuel to compensate for power lost because of increased friction losses and increased oil drag in a cold engine. The mixture is made richer during warming up by the warm-up regulator. This is a pressure regulator which lowers the pressure applied to the control plunger of the fuel regulator during warm-up. This reduced pressure causes the airflow plate to rise higher than it would do otherwise, thus uncovering a greater length of metering slot and making the mixture richer.

The valve is operated by a bi-metallic strip which is heated by an electric heater. When the engine is cold, the bi-metallic strip presses against the delivery valve spring to reduce the pressure on the diaphragm and enlarge the discharge cross-section. This increase in cross-section results in a lowering of the pressure fed to the control plunger.

Auxiliary air device

Compensation for power lost by greater friction is achieved by feeding a larger volume of fuel/air mixture to the engine than is supplied by the normal opening of the throttle. The auxiliary air device bypasses the throttle with a channel having a variable aperture valve in it. The aperture is varied by a pivoted plate controlled by a spring and a bi-metallic strip.

During cold starting, the channel is open and increases the volume of air passing to the engine. As the bi-metallic strip bends, it allows a control spring to pull the plate over the aperture until at normal operating temperature the aperture is closed.

Cold acceleration enrichment

This system is fitted to later models only. When the engine is cold (below 35°C), acceleration is improved by briefly enriching the fuel mixture for a period of approximately 0.4 seconds. This cold acceleration enrichment will only operate if the thermotime switch, the diaphragm pressure switch and the throttle valve switch are shut off.

Temperature sensor

From March 1986, a temperature sensor is located between injectors 1 and 2. After switching off the ignition, this switches on the cooling fan when the temperature of the cylinder head exceeds 110°C. A time relay is incorporated in the circuit. This switches off the function between ten and twelve minutes after switching off the ignition.

Precautions

Fuel warning

Many of the procedures in this Chapter require the removal of fuel lines and connections which may result in some fuel spillage. Before carrying out any operation on the fuel system, refer to the precautions given in Safety first! at the beginning of this Manual and follow them implicitly. Petrol is a highly

dangerous and volatile liquid and the precautions necessary when handling it cannot be overstressed.

Fuel injection system warning

Residual pressure will remain in the fuel lines long after the vehicle was last used, therefore extra care must be taken when disconnecting a fuel line.

Loosen any fuel line slowly to avoid a sudden release of pressure which may cause fuel spray. As an added precaution, place a rag over each union as it is disconnected to catch any fuel which is forcibly expelled.

Take particular care to ensure that no dirt is allowed to enter the system. The ignition must be off and the battery disconnected.

Unleaded petrol - usage

Refer to Part A of this Chapter.

Catalytic converters

Before attempting work on these items, carefully read the precautions listed in the following Section.

2 Catalytic converters - general information and precautions

The catalytic converter is a reliable and simple device which needs no maintenance in itself, but there are some facts of which an owner should be aware if the converter is to function properly for its full service life.

- a) *DO NOT use leaded petrol in a vehicle equipped with a catalytic converter - the lead will coat the precious metals, reducing their converting efficiency and will eventually destroy the converter.*
- b) *Always keep the ignition and fuel systems well-maintained in accordance with the manufacturer's schedule. Ensure that the air cleaner element, fuel filter and spark plugs are renewed at the correct intervals. If the inlet air/fuel mixture is allowed to become too rich due to neglect, the unburned surplus will enter and burn in the catalytic converter, overheating the element and eventually destroying the converter.*
- c) *If the engine develops a misfire, do not drive the vehicle at all (or at least as little as possible) until the fault is cured. The misfire will allow unburned fuel to enter the converter, which will result in its overheating.*
- d) *DO NOT push or tow-start the vehicle. This will soak the catalytic converter in unburned fuel, causing it to overheat when the engine does start.*
- e) *DO NOT switch off the ignition at high engine speeds. If the ignition is switched off at anything above idle speed, unburned fuel will enter the (very hot) catalytic converter, with the possible risk of its igniting on the element and damaging the converter.*

- f) **DO NOT** use fuel or engine oil additives as these may contain substances harmful to the catalytic converter.
- g) **DO NOT** continue to use the vehicle if the engine burns oil to the extent of leaving a visible trail of blue smoke. The unburned carbon deposits will clog the converter passages and reduce its efficiency. In severe cases, the element will overheat.
- h) Remember that the catalytic converter operates at very high temperatures, hence the heat shields on the vehicle's underbody. The casing will become hot enough to ignite combustible materials which brush against it. **DO NOT**, therefore, park the vehicle in dry undergrowth, over long grass or piles of dead leaves.
- i) Remember that the catalytic converter is **FRAGILE**. Do not strike it with tools during servicing work, take great care when working on the exhaust system, ensure that the converter is well clear of any jacks or other lifting gear used to raise the vehicle and do not drive the vehicle over rough ground, road humps etc. in such a way as to 'ground' the exhaust system.
- j) In some cases, particularly when the vehicle is new and/or is used for stop/start driving, a sulphurous smell (like that of rotten eggs) may be noticed from the exhaust. This is common to many catalytic converter-equipped vehicles and seems to be due to the small amount of sulphur found in some petrols reacting with hydrogen in the exhaust to produce hydrogen sulphide (H₂S) gas. While this gas is toxic, it is not produced in sufficient amounts to be a problem. Once the vehicle has covered a few thousand miles the problem should disappear. In the meantime, a change of driving style or brand of petrol used may effect a solution.
- k) The catalytic converter used on a well-maintained and well-driven vehicle, should last for between 50 000 and 100 000 miles. From this point on, careful checks should be made at all specified service intervals of the CO level to ensure that the converter is still operating efficiently. If the converter is no longer effective, it must be renewed.

3 Air cleaner element - renewal

Refer to Chapter 1, Section 32

4 Idle speed - adjustment

- 1 Run the engine until the oil temperature is at least 80°C. Do not let the engine coolant temperature rise above normal as the electric

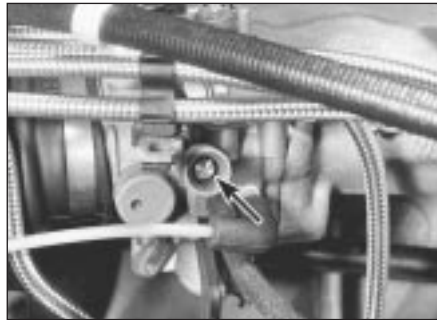

4.6 Idle speed adjustment screw location in throttle valve housing (arrowed)

radiator fan will run and this should not be operating when checking or adjusting idle speed.

- 2 Check the ignition timing and adjust if necessary.

- 3 Except on air conditioned models, the main headlights should be turned on. Disconnect and plug the crankcase breather hose from the valve cover.

- 4 Where air conditioning is fitted, the system must be switched off during checking and adjustment.

- 5 If the injector pipes have been reconnected just prior to checking the idle speed, run the engine up to 3000 rpm a few times and then let it idle for a minimum period of two minutes before checking the idle speed.

- 6 If adjustment to the idle speed is necessary, remove the locking cap from the adjustment screw on the throttle assembly and turn the screw to achieve the specified idle speed (see illustration). Adjustment should be made only when the radiator fan is stationary.

- 7 If an exhaust gas analyser is available, check the CO reading and compare it with the specified figure. If necessary adjust the idle mixture.

- 8 Air conditioned models will also be fitted with an increased idle speed valve and, in some instances, a second idle speed boost valve. To check these, refer to Sections 5 or 6, as applicable.

5 Increased idling speed valve (air conditioned models) - testing

- 1 Start and run the engine at its normal idle speed.

- 2 With the air conditioner switched off, pinch the hose at the increased idle speed valve (see illustration). The engine speed should not change.

- 3 Switch the air conditioning system on and then repeat the test. This time the engine speed should drop. If these tests prove the valve to be faulty then it must be renewed.

- 4 Disconnect the hose, unclip and detach the wiring connector then unbolt and remove the valve from its support bracket.

- 5 Refit in the reverse order of removal.



5.2 Increased idling speed valve (air conditioned models)

6 Idle speed boost (air conditioned models) - testing and idle speed adjustment

General

- 1 The function of this device is to stabilise the engine speed when it drops below 700 rpm under certain operating conditions. This is achieved by increasing the air supply to the engine, which raises the idling speed to approximately 1050 rpm. At this point, the air supply valve is cut off and the idle speed then returns to normal. The two valves which control this system are attached to the right-hand front suspension mounting in the engine compartment (see illustration).

- 2 Valve No. 1 (inboard side) increases the engine speed when it drops below 700 rpm, whilst valve No. 2 (outboard side) increases the idle speed when the air conditioner is switched on.

Valve 1 - testing and idle speed adjustment

- 3 Run the engine up to its normal operating temperature, switch off the air conditioner and allow the engine to idle. With the exception of the air conditioner, switch on all electrical consumers (lights, etc.), then adjust the idle speed to 700 rpm. When reaching idle speed, the valve should open and the idle speed increase. Using a pair of pliers, pinch the air hose from the valve then check that the speed drops.



6.1 Idle speed boost valve check

1 Valve No 1 2 Valve No 2 3 Hose



7.2 Idle CO adjustment screw location (arrowed)

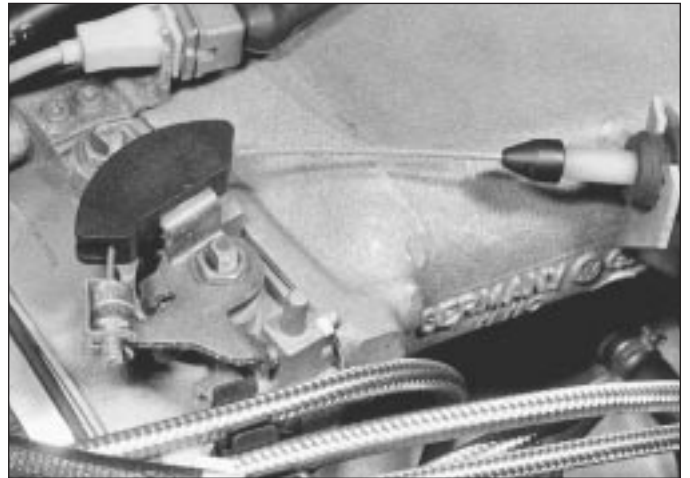

8.2 Accelerator cable connection to throttle valve

4 Switch off all electrical consumers, then pinch the air hose again and adjust idle speed to that specified. When the correct idle speed is reached, unclamp the hose. The idle speed should then increase up to about 1050 rpm at which point the valve will close and the speed drop to the specified idle speed setting.

Valve 2 - checking

5 Run the engine at normal idle speed with the air conditioner switched off. Pinch the air hose and check that the engine speed remains the same.

6 Now switch the air conditioning on and repeat the test. When the hose is pinched, the engine speed should drop.

7 If the air hose and/or valves Nos. 1 or 2 are disconnected or removed for any reason, it is important when refitting to note that the three-way hose connector large hole must go to valve No. 2.

6 Turn the adjusting screw clockwise to raise the percentage of CO and anti-clockwise to lower it. It is important that the adjustment is made without pressing down on the adjusting screw, because this will move the airflow sensor plate and affect the adjustment.

7 Remove the tool, accelerate the engine briefly and re-check. If the tool is not removed before the engine is accelerated, there is a danger of the tool becoming jammed and getting bent.

8 Recheck that the idle speed is correct and further adjust if necessary.

9 When reconnection of the crankcase ventilation hose results in an increase in the CO content, the engine oil is diluted with fuel and should be renewed. Alternatively, if an oil change is not due, a long fast drive will reduce the amount of fuel in the oil.

3 Release the inner cable from the control quadrant and the outer cable from the location/adjustment bracket on top of the inlet manifold.

4 Prise free and remove the plastic cover from the top of the bulkhead trough.

5 Working inside the vehicle, remove the lower fascia panel on the driver's side.

6 Unclip the inner cable from the accelerator pedal, then withdraw the complete cable into the engine compartment, together with the rubber grommets.

Refitting

7 Refitting is a reversal of removal, but ensure that the cable run is not kinked and is correctly aligned, then adjust the cable.

Adjustment

8 Ask an assistant to fully depress the accelerator pedal whilst the cable position is set at the throttle valve housing end.

9 When the throttle valve is fully open, there should be a 1.0 mm clearance between the throttle valve lever and the stop (see illustration).

10 Adjust by altering the cable retainer position at the location/adjustment bracket (see illustration).

7 Idle mixture - adjustment



Note: Accurate idle mixture adjustment can only be made using an exhaust gas analyser

1 The idle CO adjustment screw alters the height of the fuel metering distributor plunger relative to the air control plate of the air flow meter.

2 The screw is accessible by removing the locking plug from between the air duct scoop and the fuel metering distributor on the airflow meter casing (see illustration).

3 Although a special tool is recommended for this adjustment, it can be made using a long, thin screwdriver.

4 Ensure that the engine is running under the same conditions as those necessary for adjusting the idling speed and that the idling speed is correct.

5 Connect an exhaust gas analyser to the tailpipe, as directed by the equipment manufacturer, and read the CO level.

8 Accelerator cable - removal, refitting and adjustment



Removal

1 Disconnect the battery earth lead.
2 Prise free the inner cable retaining clip from the throttle valve control on the throttle valve housing (see illustration).

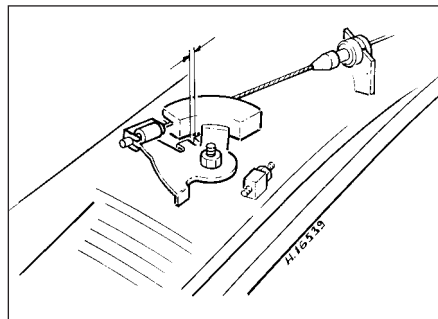

8.9 Accelerator cable clearance at full throttle position (arrowed)



8.10 Accelerator cable adjuster and support bracket

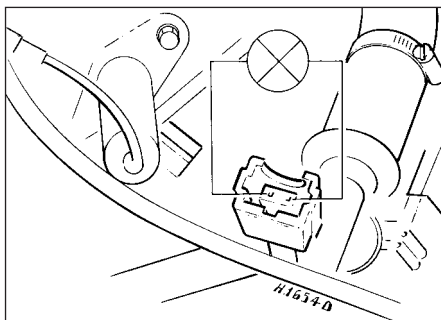

9.3 Cold start valve test lamp connections



10.3 Auxiliary air valve (arrowed)



11.2 Warm-up valve

9 Cold start valve and thermotime switch - testing



Cold start valve

- 1 The thermotime switch energises the cold start valve for a short time on starting. The time for which the valve is switched on depends upon the engine temperature.
- 2 This check must only be carried out when the coolant temperature is below 30°C.
- 3 Pull the connector off the cold start valve and connect a test lamp across the contacts of the connector (see illustration).
- 4 Pull the high tension lead off the centre of the distributor and connect the lead to earth.
- 5 Pull the connector from the thermotime switch then connect an extension lead from earth to the thermotime switch W terminal (green/white wire). The red/black wire must not be earthed.
- 6 Operate the starter and check that the test lamp lights up. If it does not, then there is an open circuit which must be located and repaired.
- 7 To check the cold start valve, leave the thermotime switch W terminal earthed, remove the cold start valve and re-attach its connector. Take care not to break the gasket when withdrawing the cold start valve from the inlet manifold.
- 8 With fuel line and electrical connections connected to the valve, hold the valve over a glass jar and operate the starter for 10 seconds. The cold start valve should produce an even cone of spray during the time the thermotime switch is on.
- 9 Wipe dry the cold start valve nozzle with a clean non-fluffy cloth, then check that the valve does not drip or its body become damp over a period of one minute. If proved defective, renew the valve.

Thermotime switch

- 10 To check the thermotime switch, proceed as described in paragraphs 3 and 4 inclusive. The coolant should be at 30°C. If the switch needs to be cooled down to the temperature specified, remove it and immerse its base in

cold water. When cooled, earth the switch to make the test.

- 11 Operate the starter for 10 seconds. The test lamp should light immediately and stay on for three seconds.

- 12 Refit the high tension lead onto the distributor and reconnect the lead to the cold start valve.

10 Auxiliary air valve - testing



- 1 To carry out this test, the engine coolant temperature must be below 30°C.
- 2 Detach the distributor HT lead.
- 3 Detach the auxiliary air valve electrical plug and ensure that the contacts in the plug connector are in good condition (see illustration).
- 4 Connect up a voltmeter across the contacts of the plug connectors, start the engine and run at idle speed. The voltage reading must be a minimum of 11.6 V. If a voltmeter is not available, a test lamp will suffice to check the voltage supply.
- 5 With the auxiliary air valve electrical plug still detached, leave the engine running at idle speed and pinch the air inlet duct-to-auxiliary valve hose. The engine speed should drop.

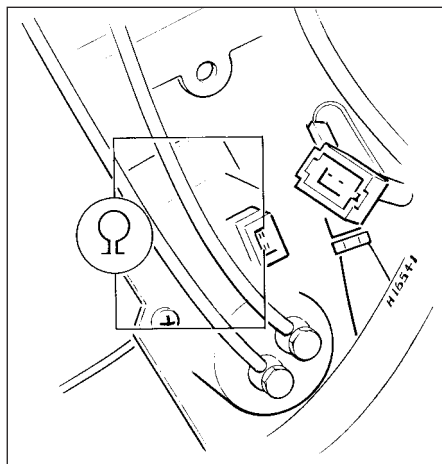

11.4 Warm-up valve heater coil resistance test

- 6 When the engine is warmed up to normal operating temperature, reconnect the auxiliary valve plug then pinch the hose again. This time the engine speed should remain unaltered.

11 Warm-up valve - testing



- 1 Detach the distributor HT lead and earth it.
- 2 With the engine cold, detach the wiring connector from the warm-up valve (see illustration).
- 3 Connect a voltmeter across the terminals of the warm-up valve connector and operate the starter. The voltage across the terminals should be a minimum of 11.5 volts.
- 4 Switch the ignition off and connect an ohmmeter across the terminals of the warm-up valve (see illustration). If the meter does not indicate a resistance of about 20 to 26 ohm, the heater coil is defective and a new valve must be fitted.

12 Cold acceleration enrichment system - testing



- 1 When the engine is cold (below 35°C), acceleration is improved by briefly enriching the fuel mixture for a period of approximately 0.4 seconds. This cold acceleration enrichment will only operate if the thermotime switch, the diaphragm pressure switch and the throttle valve switch are shut off.
- 2 To check the system, first check that the cold start valve is operational.
- 3 Detach the wiring connector from the cold start valve and connect up a test lamp to its terminals.
- 4 Detach the wiring connector from the thermotime switch and connect a length of wire between an earth point and the connector No.2 terminal W (green/white wire). Do not earth terminal G (red/black wire).
- 5 Run the engine and allow it to idle, at which point the test lamp should not light up. When the engine is quickly accelerated, the test lamp should light up briefly (0.4 seconds) (see illustration).

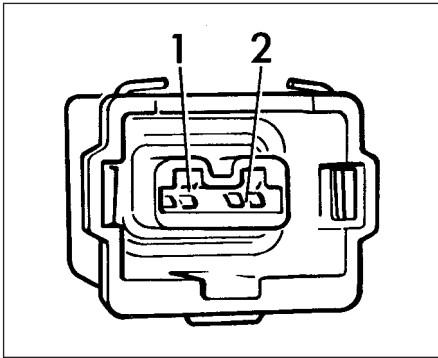

12.5 Cold acceleration enrichment system check

Cold start valve connector earth contact (2) (green/white wire to W terminal)
Do not earth contact 1

6 If a fault is evident, check the wiring connections, the throttle valve switch and the diaphragm pressure switch.

7 The diaphragm pressure switch can be checked using an ohmmeter. Detach the wiring connector from the end of the diaphragm pressure switch, then start the engine and allow it to idle. Using the ohmmeter, check the resistance reading between the contacts. An infinity reading should be given.

8 Accelerate the engine briefly and check that the resistance drops briefly and then returns to infinity (see illustration).

9 To check the throttle valve switch, detach the switch lead connector and measure the resistance between the switch contacts. An infinity reading should be given.

10 Now slowly open the throttle valve to the point where the switch is heard to operate with a click. The ohmmeter should give a 0 ohm reading and the clearance between the throttle lever and the idle stop must be between 0.2 to 0.6 mm (see illustration).

11 If necessary, adjust the switch by loosening the switch (underside of throttle housing) and

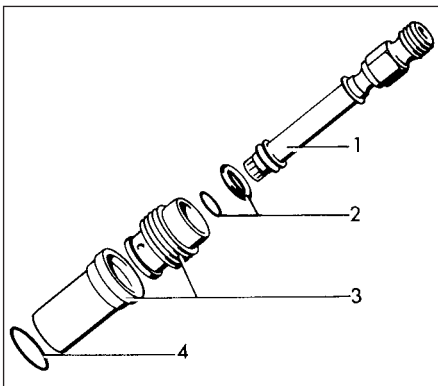

13.2 Air shrouded injector assembly (later models)

- 1 Injector
- 2 Rubber rings
- 3 Injector insert
- 4 Washer

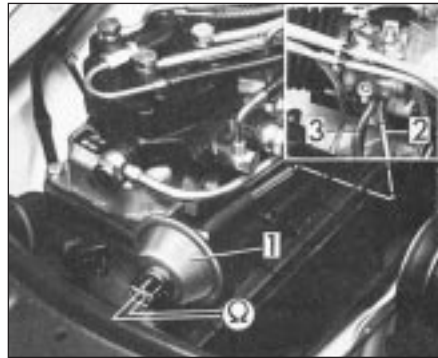

12.8 Diaphragm pressure switch test

- 1 Diaphragm pressure switch
- 2 Vacuum connection for switch (yellow)
- 3 Vacuum connection for spark control

positioning a feeler blade of 0.4 mm thickness between the lever and stop. Move the switch towards the lever until the switch is heard to operate, then retighten the switch and check adjustment.

12 If the throttle valve switch is being removed, prise the connector bracket apart to release the connector.

13 Fuel injectors - removal, testing and refitting

1 An injector may give trouble for one of the following reasons:

- a) The spray may be irregular in shape
- b) The nozzle may not close when the engine is shut down, causing flooding when restarting
- c) The nozzle filter may be choked, giving less than the required ration of fuel
- d) The seal may be damaged, allowing an air leak

2 To remove an injector for inspection, simply pull it free (see illustration).

3 Inspect the rubber seal. If it shows signs of cracking, distortion or perishing, then it must be renewed. If found to be defective, check the other injector seals as they are likely to be in similar condition.

4 Specialised tools are required for an accurate test of injector performance. However, a basic check can be made as follows.

5 Hold the injector in a suitable measuring glass and plug up the injector location hole. Start the engine and let it idle on three cylinders and look at the shape of the spray. It should be of a symmetrical cone shape. If it is not, then the injector must be changed because the vibrator pin is damaged or the spring is broken. Shut off the engine and wait for 15 seconds. There must be no leak or dribble from the nozzle. If there is, the injector must be renewed, as dribble will cause flooding and difficult starting.



12.10 Throttle valve switch check

- 1 Throttle valve switch
- a = 0.2 to 0.6 mm

6 An injector cannot be dismantled for cleaning. If an injector is renewed, the line union must be tightened to the specified torque.

7 When inserting an injector, lubricate the seal with fuel before fitting.

14 Airflow sensor plate and control plunger - testing

1 For the correct mixture to be supplied to the engine, it is essential that the sensor plate is central in the venturi and that its height is correct. First run the engine for a period of about one minute.

2 Loosen the hose clips at each end of the air scoop and remove the scoop. If the sensor plate appears to be off-centre, loosen its centre screw and carefully run a 0.10 mm feeler blade round the edge of the plate to centralise it, then re-tighten the bolt (see illustration).

3 Raise the airflow sensor plate and then quickly move it to its rest position. No resistance should be felt on the downward movement. If there is resistance, the airflow meter is defective and a new one must be fitted.



14.2 Top view of airflow sensor plate

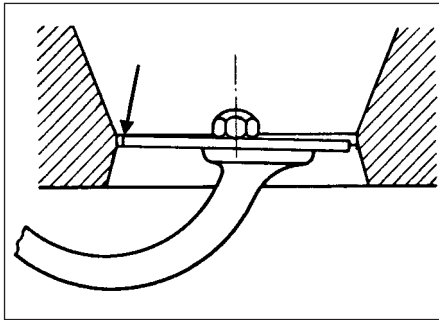

14.5 Sensor plate position requirement

Upper edge of plate (arrowed) must be flush with bottom of air cone

4 If the sensor plate can be moved downwards easily but has a strong resistance to upward movement, the control plunger is sticking. Remove the fuel distributor and clean the control plunger in fuel. If this does not cure the problem, a new fuel distributor must be fitted .

5 Release the pressure on the fuel distributor and then check the rest position of the airflow sensor plate. The upper edge of the plate should be flush with the bottom edge of the air cone (see illustration). It is permissible for the plate to be lower than the edge by not more than 0.5 mm but if higher, or lower than the permissible limit, the plate must be adjusted.

6 Adjust the height of the plate by lifting it and bending the wire clips attaching the plate to the balance arm. Take care not to scratch or damage the surface of the air cone (see illustration).

7 After adjustment, tighten the warm-up valve union and check the idle speed and CO content.



14.6 Airflow sensor plate adjustment clip (arrowed)

15 Fuel metering distributor - removal and refitting



Note: Ensure that the vehicle is in a well ventilated space and away from naked flames or other possible sources of ignition

Removal

- 1 Disconnect the battery terminals.
- 2 While holding a rag over the joint to prevent fuel from being sprayed out, loosen the control pressure line from the warm-up valve. The control pressure line is the one connected to the large union of the valve.
- 3 Mark each fuel line and its port on the distributor. Carefully clean all dirt from around the fuel unions and distributor ports and then disconnect the lines.
- 4 Unscrew and remove the connection of the pressure control line to the distributor.
- 5 Remove the locking plug from the CO adjusting screw, then remove the three screws securing the distributor (see illustration).

6 Lift off the distributor, taking care that the metering plunger does not fall out. If the plunger does fall out accidentally, clean it in fuel and then re-insert it with its chamfered end downwards.

Refitting

7 Before refitting the distributor, ensure that the plunger moves up and down freely. If the plunger sticks, the distributor must be renewed.

8 Refit the distributor, using a new sealing ring. After tightening the screws, lock them with paint.

9 Refit the fuel lines and the cap of the CO adjusting screw then tighten the union on the warm-up valve.

16 Airflow meter - removal and refitting



Removal

- 1 Remove the fuel lines from the distributor.
- 2 Loosen the clamps at the air cleaner and throttle assembly ends of the air scoop and take off the air scoop.
- 3 Remove the bolts securing the airflow meter to the air cleaner and lift off the airflow meter and fuel metering distributor (see illustration).
- 4 The plunger should be prevented from falling out when the distributor is removed from the airflow meter.

Refitting

5 Refitting is the reverse of removing. It is necessary to use a new gasket between the airflow meter and air cleaner.

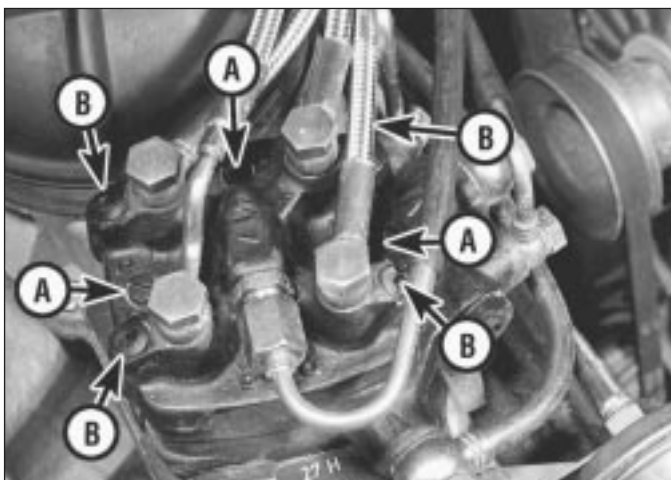

15.5 View showing fuel distributor retaining screws (A)

Do not remove screws (B)

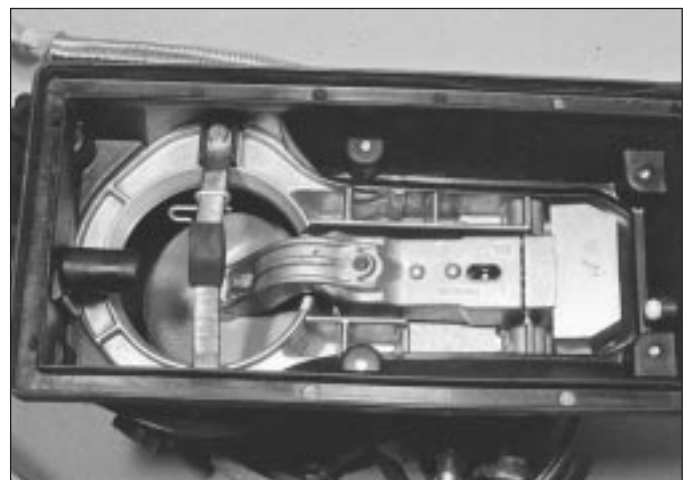

16.3 Airflow meter and fuel distributor unit (inverted)

17 Pressure relief valve - removal, servicing and refitting



- 1 Release the pressure in the fuel system.
- 2 Unscrew the non-return valve plug and remove the plug and sealing washer.
- 3 Take out the O-ring, plunger and O-ring, in that order (see illustration).
- 4 When refitting the assembly, use new O-rings and ensure that all the shims which were removed are refitted.
- 5 The number of shims fitted determine the system operating pressure. If for any reason the system pressure is suspect, it will be necessary to have a pressure check made by your VW dealer who should have the correct gauge needed to check the pressure in the system. He will know the amount of shims required to correct the pressure should it be necessary.

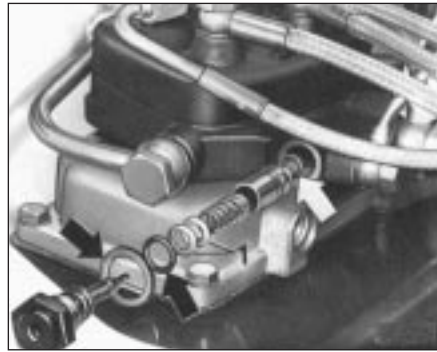

17.3 Pressure relief valve components
1 Shims Arrows indicate O-rings

detaching the Hall sender connector from the ignition system distributor.

4 Remove the fusebox and relay plate cover then pull free the pump relay from position 2.

5 Using a voltmeter, switch on the ignition and check the voltage reading between the following:

- a) Contact No. 2 and earth
- b) Contact Nos. 2 and 1
- c) Contact Nos. 4 and 1
- d) Contact Nos. 5 and 1

6 In each case, battery voltage should show.

7 Check that when the central connector wire is earthed briefly, there is a voltage drop. If the voltage does not drop, check the ignition (TCI/H switch) unit. If the voltage does drop, renew the fuel pump relay. If the problem still persists, have the ignition Hall sender unit checked.

Removal

8 If after making the above checks the pump still malfunctions, remove the sender unit as described in Part A of this Chapter, Section 8, then detach the pump for renewal.

Refitting

9 Refitting is a reversal of the removal procedure.

19 Fuel pump - removal and refitting



Removal

1 The fuel pump is located on the underside of the vehicle, forwards of the fuel tank on the right-hand side, the pump being housed in the pump reservoir (see illustrations).

2 Disconnect the battery earth lead.

3 Raise the vehicle at the rear and support it on axle stands (see "Jacking and vehicle support").

4 Prise free the retaining clip and detach the pump wiring connector (see illustration).

5 Unscrew the damper unit from the rear end of the pump and detach the hose union, noting the washer each side of the union.

6 Undo the retaining nuts and washers and remove the adapter.

7 Undo the three screws securing the pump retaining ring and withdraw the ring, followed by the pump unit.

8 Remove the O-ring and withdraw the strainer.

Refitting

9 Refitting is a reversal of the removal procedure. Smear the O-ring with fuel when fitting and check that it does not become distorted.

10 When fitting the pump, position it so that its lug engages with the slot in the retaining ring.

11 If the pump non-return valve was removed from the rear end of the pump, refit it using a new seal washer. Also use a new seal washer each side of the hose union. Tighten the damper unit to the specified torque.

12 On completion, start the engine and check for any signs of fuel leakage from the pump connections.

18 Fuel lift pump - testing, removal and refitting



Testing

1 The fuel lift pump is attached to the base of the fuel gauge sender unit fitted to the fuel tank (see illustration).

2 If the pump is suspected of malfunction, first check that the pump wiring does not have an open circuit. Remove the luggage compartment floor covering and the circular cover in the floor for access to the sender unit and connections. Detach the wiring connector and make a continuity check between the centre wires and the outer (brown) wire of the connector (see illustration).

3 If the wiring proves correct, then check the pump relay and pump fuse (No. 5). Assuming the fuse to be in order, check the relay by first

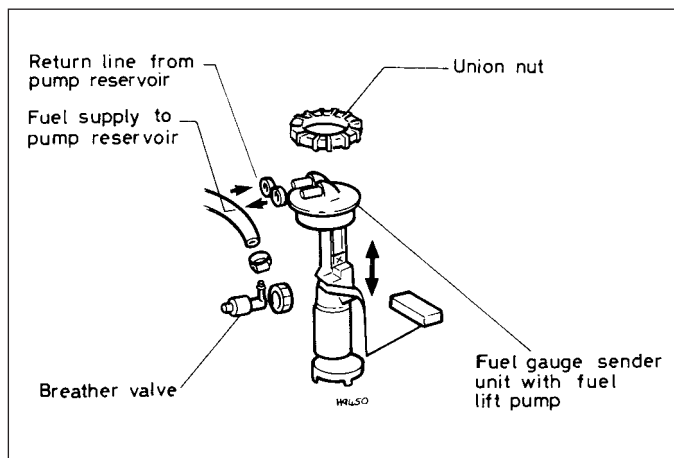

18.1 Fuel tank sender unit

Tank and other associated components are identical to those used for carburettor engines



18.2 Fuel tank sender unit and connections

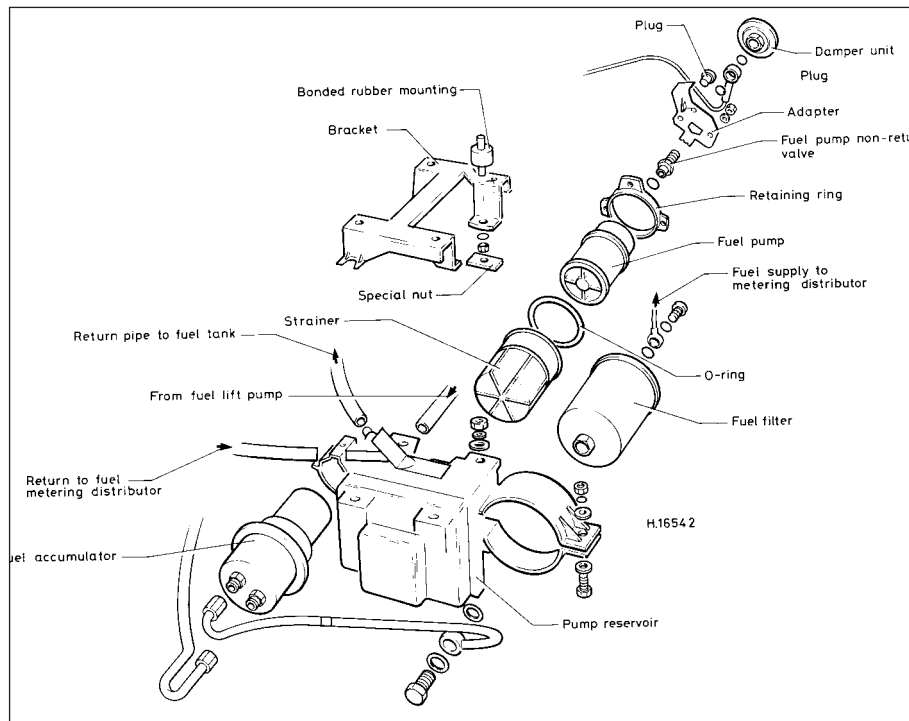

19.1a Fuel pump and associated components



19.1b Fuel pump viewed from rear



19.4 Disconnecting wiring connector from fuel pump

20 Fuel filter - removal and refitting

Refer to Chapter 1, Section 33

21 Fuel accumulator - removal and refitting

Removal

- 1 The fuel accumulator is mounted on the outboard side of the fuel pump reservoir on the underside of the vehicle at the rear, just forward of the fuel tank (see illustration).
- 2 Disconnect the battery earth lead.
- 3 Raise the vehicle at the rear and support it on axle stands (see "Jacking and vehicle support").



21.1 Fuel accumulator unit location

- 4 Disconnect the fuel pipes from their connections at the front end of the regulator.
- 5 Undo the clamp bolt and withdraw the accumulator.

Refitting

- 6 Refit in the reverse order to removal. Check that the fuel line connections are clean before refitting. On completion, check for fuel leaks with the engine running.

22 Fuel tank and associated components - removal and refitting

The fuel tank and associated components can be removed and refitted in the same manner as described for carburettor models in Part A of this Chapter.

To test the breather valve, blow through the hose (dotted arrow - see illustration 7.3 in Part A of this Chapter) and push the lever in to see if the airflow opens then shuts off as the lever is released. If defective, renew the valve.

23 Inlet manifold - removal and refitting

Note: Access to many of the fastenings and fittings of the manifold, on the bulkhead side in particular, is not good due to the close proximity of adjacent components. It may therefore be found necessary to at least partially disconnect and remove the

engine/gearbox unit to gain access to certain items and allow clearance for manifold removal.

Modification: As from September 1984, components associated with the inlet manifold were modified (see illustration). All work procedures remain as follows for engines manufactured before that date (see illustration).

Removal

- 1 Disconnect the battery earth lead and decompress the fuel system.
- 2 Disconnect the accelerator cable from the throttle valve and support/adjuster bracket on the manifold.
- 3 Disconnect the wiring connector and the vacuum hose from the auxiliary air valve.
- 4 Disconnect the wiring and detach the warm-up valve.
- 5 Undo the hose clips and detach the vacuum hose from the connection on the end of the manifold (left side) and the rear side of the throttle valve housing (see illustration).
- 6 Disconnect the vacuum hoses from the front of the throttle housing, noting their connections.
- 7 Disconnect the injectors and hoses from the cylinder head, release them from the location clips and fold them back out of the way.
- 8 Unclip and detach the inlet ducting from the throttle housing.
- 9 Remove the bolts and disconnect the support bracket from the accelerator cable support/adjuster bracket and from the cam cover.

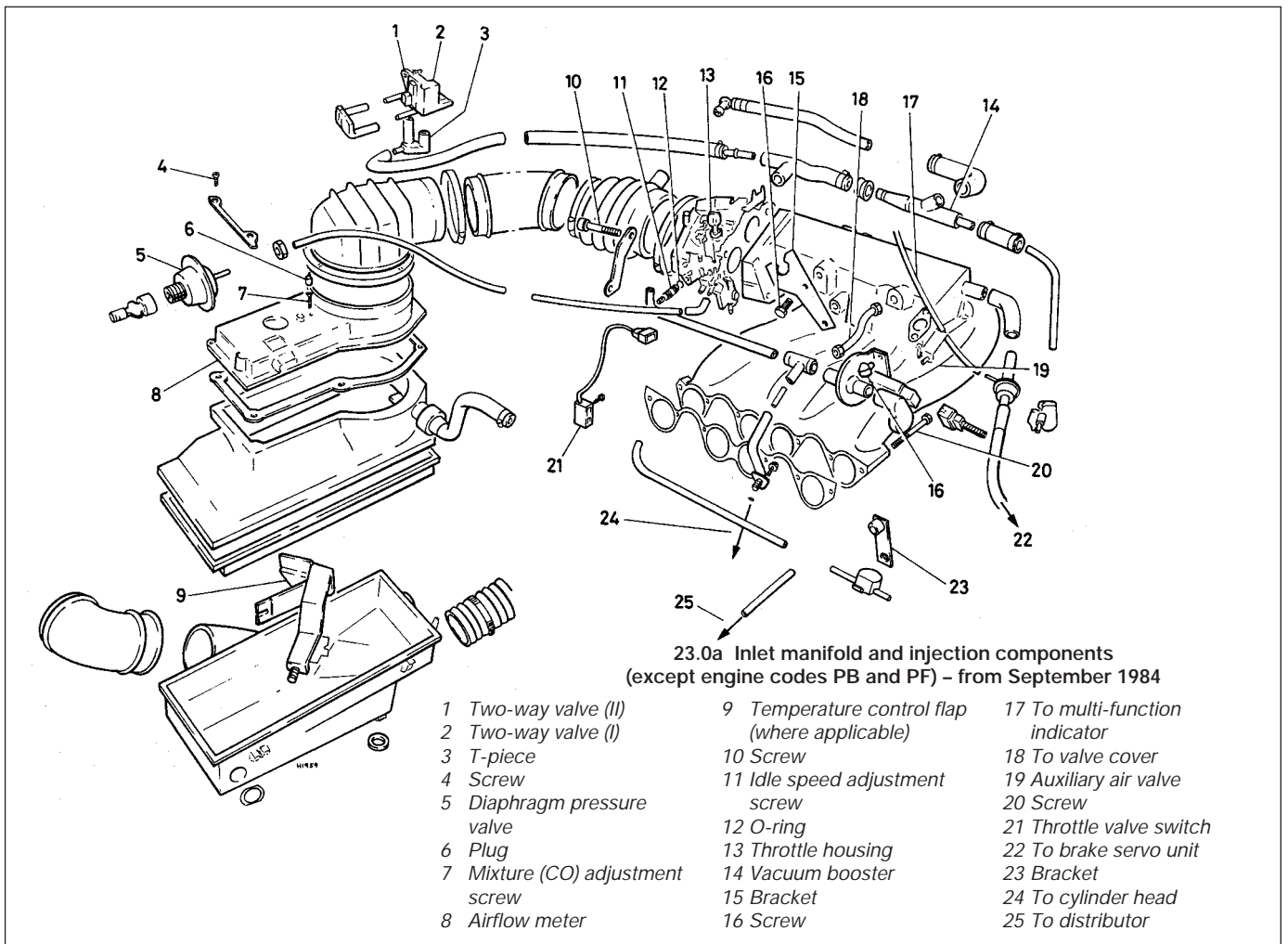

4B

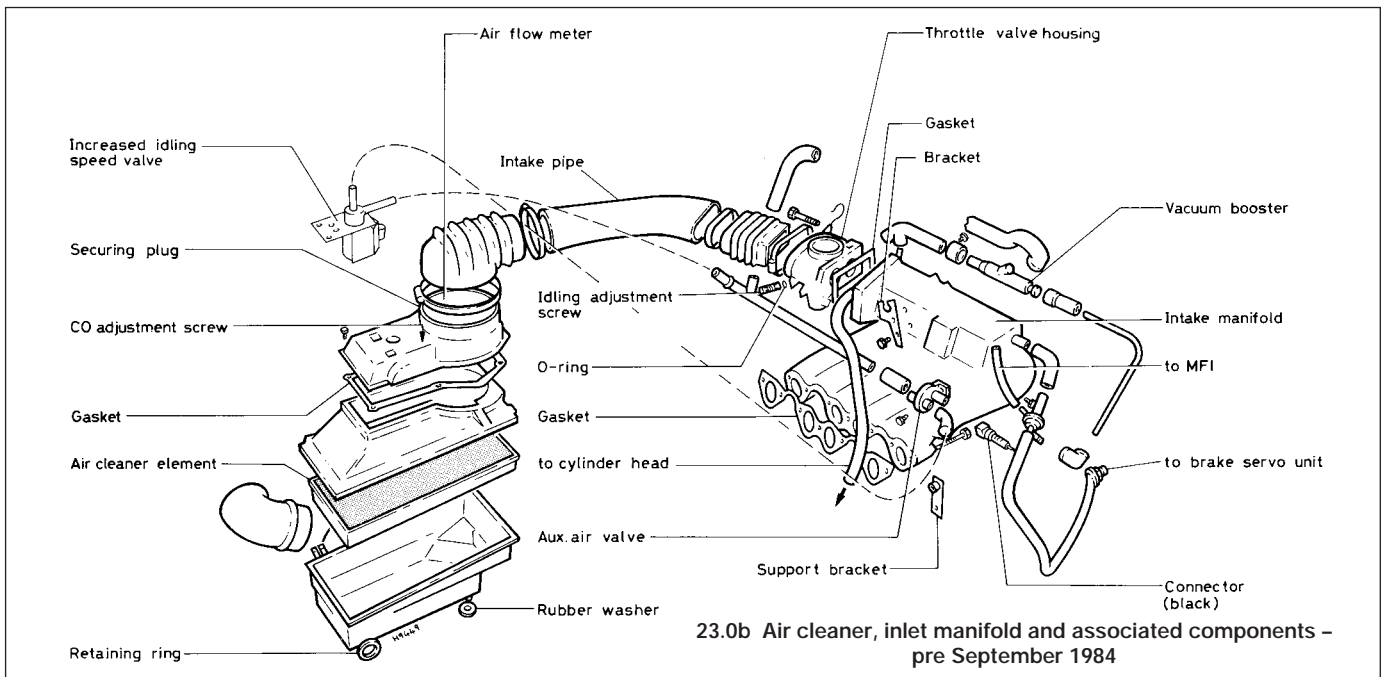



23.5 Vacuum hose-to-cylinder connector

10 Disconnect the cam cover-to-inlet manifold breather hose.

11 Undo and remove the inlet manifold retaining bolts then carefully lift the manifold, together with the throttle housing, away from the cylinder head. Disconnect any wiring or hose connections still attached as it is withdrawn.

12 The throttle housing can be unbolted from the manifold and then withdrawn from it.

Refitting

13 Refitting is a reversal of the removal procedure. Check that all mating faces are clean and use new gaskets. Tighten the securing bolts to the specified torque settings.

14 When reconnecting the accelerator cable, ensure it is correctly adjusted.

15 Check that all connections are secure and correctly made before restarting the vehicle.

24 Exhaust manifold - removal and refitting



Note: Before starting to remove the manifold, refer to Part A of this Chapter, Section 20, paragraph 1, which concerns details on the special tool required to release and subsequently reconnect the exhaust manifold-to-downpipe securing clips. Unless this tool is available, the manifold is best removed and refitted by your VW dealer

Remove the inlet manifold.

Removal and refitting of the exhaust manifold is now similar to that procedure described in Part A of this Chapter.

25 Exhaust system - inspection, removal and refitting



Without catalytic converter

1 Refer to Section 20 in Part A of this Chapter whilst noting that all models manufactured after August 1985 are fitted with a manifold/downpipe flange incorporating a gasket instead of spring clips.

With catalytic converter

2 The catalytic converter (where fitted) is positioned at the forward end of the exhaust system and comprises a steel casing over a ceramic body. It incorporates a longitudinal multi-passage honeycomb unit, which is coated with a layer of platinum or rhodium.

3 Removal is simply a matter of releasing the flange or socket type couplings and separating the components (see illustration).

4 Note that the catalytic converter is fragile. Do not strike it with tools and take care not to allow it to contact jacks or lifting gear.

5 Always use new coupling seals and gaskets during reassembly.

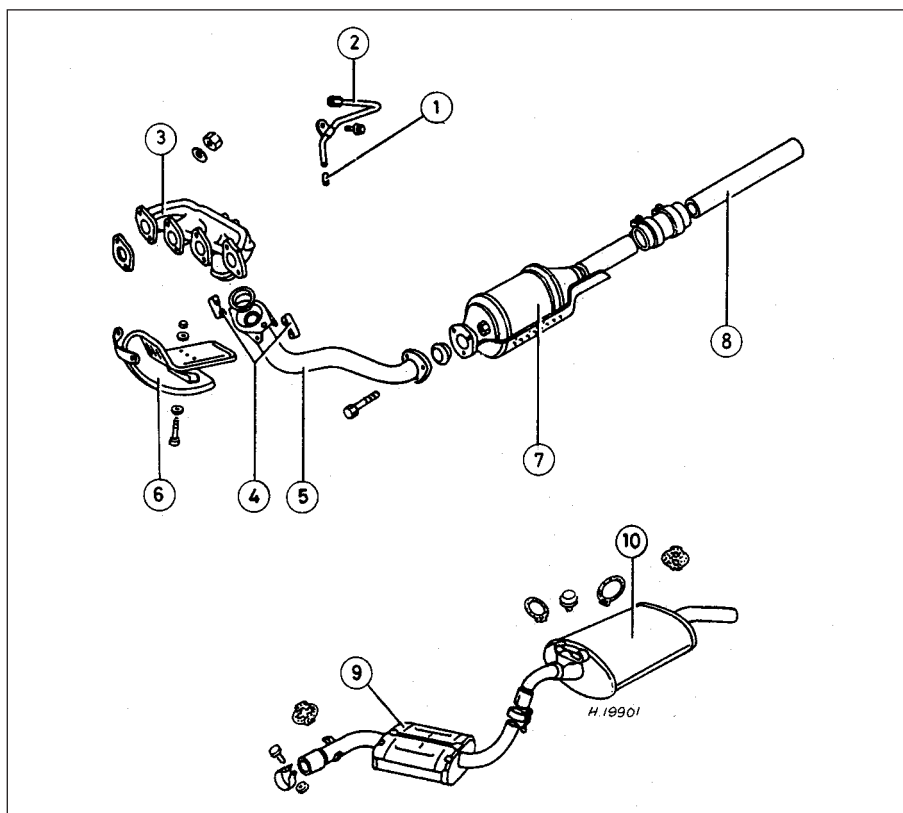

25.3 Typical exhaust system with catalyst

- | | | |
|---------------------|-----------------------|---------------------|
| 1 Cap | 4 Spring clips | 8 Intermediate pipe |
| 2 CO measuring pipe | 5 Exhaust front pipe | 9 Centre silencer |
| 3 Exhaust manifold | 6 Heat shield | 10 Rear silencer |
| | 7 Catalytic converter | |