

# SERIES dc CIRCUITS

# 5

## OBJECTIVES

- **Become familiar with the characteristics of a series circuit and how to solve for the voltage, current, and power to each of the elements.**
- **Develop a clear understanding of Kirchhoff's voltage law and how important it is to the analysis of electric circuits.**
- **Become aware of how an applied voltage will divide among series components and how to properly apply the voltage divider rule.**
- **Understand the use of single- and double-subscript notation to define the voltage levels of a network.**
- **Learn how to use a voltmeter, ammeter, and ohmmeter to measure the important quantities of a network.**

## 5.1 INTRODUCTION

Two types of current are readily available to the consumer today. One is *direct current* (dc), in which ideally the flow of charge (current) does not change in magnitude (or direction) with time. The other is *sinusoidal alternating current* (ac), in which the flow of charge is continually changing in magnitude (and direction) with time. The next few chapters are an introduction to circuit analysis purely from a dc approach. The methods and concepts are discussed in detail for direct current; when possible, a short discussion suffices to cover any variations we may encounter when we consider ac in the later chapters.

The battery in Fig. 5.1, by virtue of the potential difference between its terminals, has the ability to cause (or “pressure”) charge to flow through the simple circuit. The positive terminal attracts the electrons through the wire at the same rate at which electrons are supplied by the negative terminal. As long as the battery is connected in the circuit and maintains its terminal characteristics, the current (dc) through the circuit will not change in magnitude or direction.

If we consider the wire to be an ideal conductor (that is, having no opposition to flow), the potential difference  $V$  across the resistor equals the applied voltage of the battery:  $V$  (volts) =  $E$  (volts).

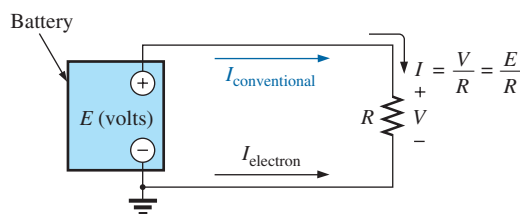
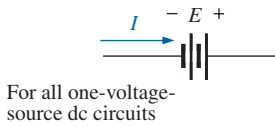


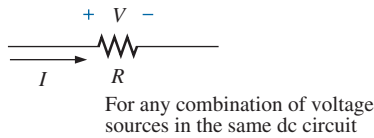
FIG. 5.1

Introducing the basic components of an electric circuit.



**FIG. 5.2**

Defining the direction of conventional flow for single-source dc circuits.



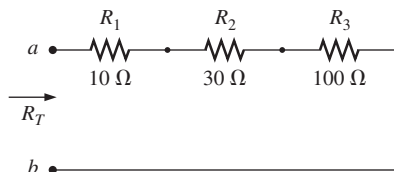
**FIG. 5.3**

Defining the polarity resulting from a conventional current  $I$  through a resistive element.

The current is limited only by the resistor  $R$ . The higher the resistance, the less the current, and conversely, as determined by Ohm's law.

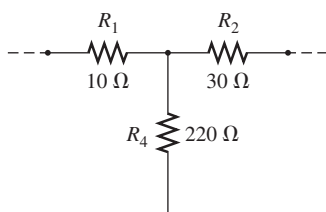
By convention (as discussed in Chapter 2), the direction of **conventional current flow** ( $I_{\text{conventional}}$ ) as shown in Fig. 5.1 is opposite to that of **electron flow** ( $I_{\text{electron}}$ ). Also, the uniform flow of charge dictates that the direct current  $I$  be the same everywhere in the circuit. By following the direction of conventional flow, we notice that there is a rise in potential across the battery ( $-$  to  $+$ ), and a drop in potential across the resistor ( $+$  to  $-$ ). For single-voltage-source dc circuits, conventional flow always passes from a low potential to a high potential when passing through a voltage source, as shown in Fig. 5.2. However, conventional flow always passes from a high to a low potential when passing through a resistor for any number of voltage sources in the same circuit, as shown in Fig. 5.3.

The circuit in Fig. 5.1 is the simplest possible configuration. This chapter and the following chapters add elements to the system in a very specific manner to introduce a range of concepts that will form a major part of the foundation required to analyze the most complex system. Be aware that the laws, rules, and so on, introduced in Chapters 5 and 6 will be used throughout your studies of electrical, electronic, or computer systems. They are not replaced by a more advanced set as you progress to more sophisticated material. It is therefore critical that you understand the concepts thoroughly and are able to apply the various procedures and methods with confidence.



**FIG. 5.4**

Series connection of resistors.



**FIG. 5.5**

Configuration in which none of the resistors are in series.

## 5.2 SERIES RESISTORS

Before the series connection is described, first recognize that every fixed resistor has only two terminals to connect in a configuration—it is therefore referred to as a **two-terminal device**. In Fig. 5.4, one terminal of resistor  $R_2$  is connected to resistor  $R_1$  on one side, and the remaining terminal is connected to resistor  $R_3$  on the other side, resulting in one, and only one, connection between adjoining resistors. When connected in this manner, the resistors have established a series connection. If three elements were connected to the same point, as shown in Fig. 5.5, there would not be a series connection between resistors  $R_1$  and  $R_2$ .

For resistors in series,

*the total resistance of a series configuration is the sum of the resistance levels.*

In equation form for any number ( $N$ ) of resistors,

$$R_T = R_1 + R_2 + R_3 + R_4 + \dots + R_N \tag{5.1}$$

A result of Eq. (5.1) is that

*the more resistors we add in series, the greater the resistance, no matter what their value.*

Further,

*the largest resistor in a series combination will have the most impact on the total resistance.*

For the configuration in Fig. 5.4, the total resistance would be

$$\begin{aligned} R_T &= R_1 + R_2 + R_3 \\ &= 10 \Omega + 30 \Omega + 100 \Omega \end{aligned}$$

and

$$R_T = 140 \Omega$$

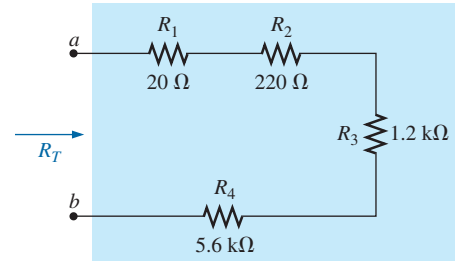
**EXAMPLE 5.1** Determine the total resistance of the series connection in Fig. 5.6. Note that all the resistors appearing in this network are standard values.

**Solution:** Note in Fig. 5.6 that even though resistor  $R_3$  is on the vertical and resistor  $R_4$  returns at the bottom to terminal  $b$ , all the resistors are in series since there are only two resistor leads at each connection point. Applying Eq. (5.1):

$$R_T = R_1 + R_2 + R_3 + R_4$$

$$R_T = 20 \Omega + 220 \Omega + 1.2 \text{ k}\Omega + 5.6 \text{ k}\Omega$$

and  $R_T = 7040 \Omega = \mathbf{7.04 \text{ k}\Omega}$



**FIG. 5.6**  
Series connection of resistors for Example 5.1.

For the special case where resistors are the *same value*, Eq. (5.1) can be modified as follows:

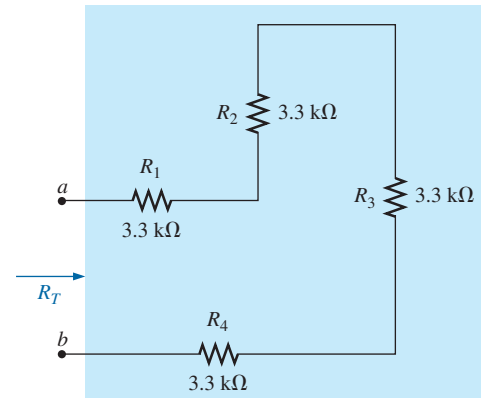
$$R_T = NR \tag{5.2}$$

where  $N$  is the number of resistors in series of value  $R$ .

**EXAMPLE 5.2** Find the total resistance of the series resistors in Fig. 5.7. Again, recognize  $3.3 \text{ k}\Omega$  as a standard value.

**Solution:** Again, don't be concerned about the change in configuration. Neighboring resistors are connected only at one point, satisfying the definition of series elements.

Eq. (5.2):  $R_T = NR$   
 $= (4)(3.3 \text{ k}\Omega) = \mathbf{13.2 \text{ k}\Omega}$

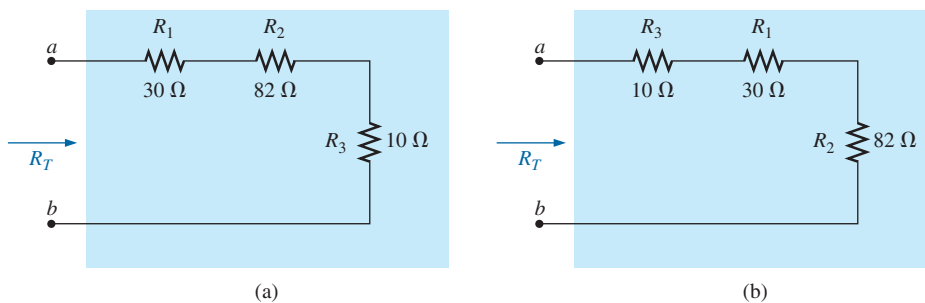


**FIG. 5.7**  
Series connection of four resistors of the same value (Example 5.2).

It is important to realize that since the parameters of Eq. (5.1) can be put in any order,

*the total resistance of resistors in series is unaffected by the order in which they are connected.*

The result is that the total resistance in Fig. 5.8(a) and (b) are both the same. Again, note that all the resistors are standard values.



**FIG. 5.8**  
Two series combinations of the same elements with the same total resistance.

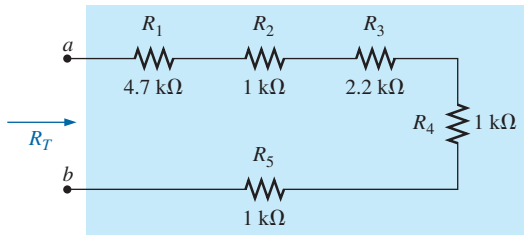


FIG. 5.9

Series combination of resistors for Example 5.3.

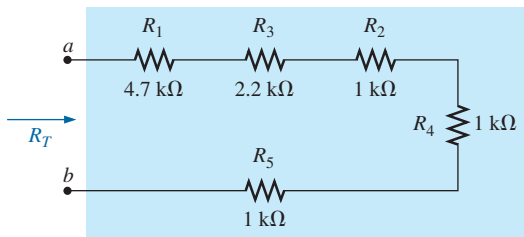


FIG. 5.10

Series circuit of Fig. 5.9 redrawn to permit the use of Eq. (5.2):  $R_T = NR$ .

**EXAMPLE 5.3** Determine the total resistance for the series resistors (standard values) in Fig. 5.9.

**Solution:** First, the order of the resistors is changed as shown in Fig. 5.10 to permit the use of Eq. (5.2). The total resistance is then

$$R_T = R_1 + R_3 + NR_2 \\ = 4.7 \text{ k}\Omega + 2.2 \text{ k}\Omega + (3)(1 \text{ k}\Omega) = \mathbf{9.9 \text{ k}\Omega}$$

### Analogies

Throughout the text, analogies are used to help explain some of the important fundamental relationships in electrical circuits. An analogy is simply a combination of elements of a different type that are helpful in explaining a particular concept, relationship, or equation.

Two analogies that work well for the series combination of elements are connecting different lengths of rope together to make the rope longer. Adjoining pieces of rope are connected at only one point, satisfying the definition of series elements. Connecting a third rope to the common point would mean that the sections of rope are no longer in a series.

Another analogy is connecting hoses together to form a longer hose. Again, there is still only one connection point between adjoining sections, resulting in a series connection.

### Instrumentation

The total resistance of any configuration can be measured by simply connecting an ohmmeter across the access terminals as shown in Fig. 5.11 for the circuit in Fig. 5.4. *Since there is no polarity associated with resistance*, either lead can be connected to point *a*, with the other lead connected to point *b*. Choose a scale that will exceed the total resistance of the circuit, and remember when you read the response on the meter, if a kilohm scale was selected, the result will be in kilohms. For Fig. 5.11, the 200  $\Omega$  scale of our chosen multimeter was used because the total resistance is 140  $\Omega$ . If the 2 k $\Omega$  scale of our meter were selected, the digital display would read 0.140, and you must recognize that the result is in kilohms.

In the next section, another method for determining the total resistance of a circuit is introduced using Ohm's law.

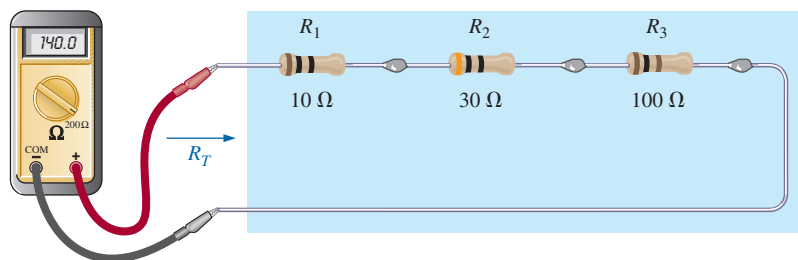


FIG. 5.11

Using an ohmmeter to measure the total resistance of a series circuit.

## 5.3 SERIES CIRCUITS

If we now take an 8.4 V dc supply and connect it in series with the series resistors in Fig. 5.4, we have the **series circuit** in Fig. 5.12.

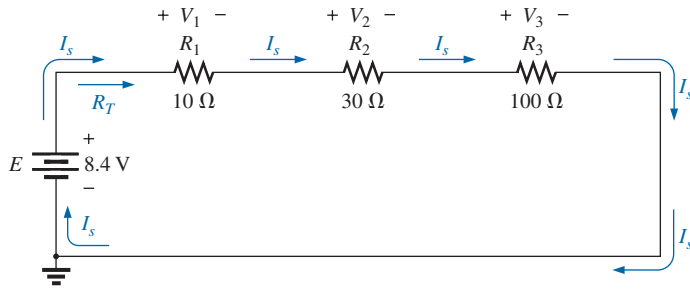


FIG. 5.12

Schematic representation for a dc series circuit.

**A circuit is any combination of elements that will result in a continuous flow of charge, or current, through the configuration.**

First, recognize that the *dc supply* is also a two-terminal device with two points to be connected. If we simply ensure that there is only one connection made at each end of the supply to the series combination of resistors, we can be sure that we have established a series circuit.

The manner in which the supply is connected determines the direction of the resulting conventional current. For series dc circuits:

**the direction of conventional current in a series dc circuit is such that it leaves the positive terminal of the supply and returns to the negative terminal, as shown in Fig. 5.12.**

One of the most important concepts to remember when analyzing series circuits and defining elements that are in series is:

**The current is the same at every point in a series circuit.**

For the circuit in Fig. 5.12, the above statement dictates that the current is the same through the three resistors and the voltage source. In addition, if you are ever concerned about whether two elements are in series, simply check whether the current is the same through each element.

**In any configuration, if two elements are in series, the current must be the same. However, if the current is the same for two adjoining elements, the elements may or may not be in series.**

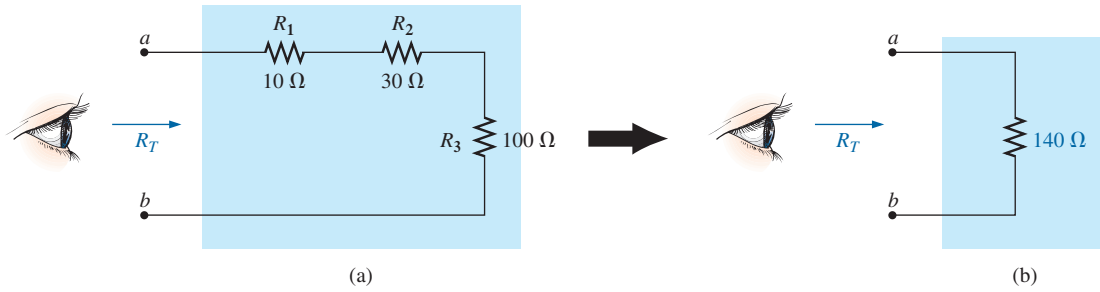
The need for this constraint in the last sentence will be demonstrated in the chapters to follow.

Now that we have a complete circuit and current has been established, the level of current and the voltage across each resistor should be determined. To do this, return to Ohm's law and replace the resistance in the equation by the total resistance of the circuit. That is,

$$I_s = \frac{E}{R_T} \quad (5.3)$$

with the subscript *s* used to indicate source current.

It is important to realize that when a dc supply is connected, it does not "see" the individual connection of elements but simply the total resistance "seen" at the connection terminals, as shown in Fig. 5.13(a). In other words, it reduces the entire configuration to one such as in Fig. 5.13(b) to which Ohm's law can easily be applied.



**FIG. 5.13**  
Resistance “seen” at the terminals of a series circuit.

For the configuration in Fig. 5.12, using the total resistance calculated in the last section, the resulting current is

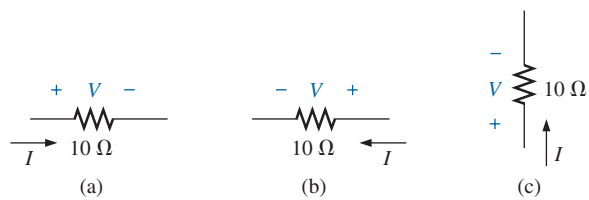
$$I_s = \frac{E}{R_T} = \frac{8.4 \text{ V}}{140 \Omega} = 0.06 \text{ A} = \mathbf{60 \text{ mA}}$$

Note that the current  $I_s$  at every point or corner of the network is the same. Furthermore, note that the current is also indicated on the current display of the power supply.

Now that we have the current level, we can calculate the voltage across each resistor. First recognize that

*the polarity of the voltage across a resistor is determined by the direction of the current.*

Current entering a resistor creates a drop in voltage with the polarity indicated in Fig. 5.14(a). Reverse the direction of the current, and the polarity will reverse as shown in Fig. 5.14(b). Change the orientation of the resistor, and the same rules apply as shown in Fig. 5.14(c). Applying the above to the circuit in Fig. 5.12 will result in the polarities appearing in that figure.



**FIG. 5.14**  
Inserting the polarities across a resistor as determined by the direction of the current.

The magnitude of the voltage drop across each resistor can then be found by applying Ohm’s law using only the resistance of each resistor. That is,

$$\begin{aligned} V_1 &= I_1 R_1 \\ V_2 &= I_2 R_2 \\ V_3 &= I_3 R_3 \end{aligned} \tag{5.4}$$



which for Fig. 5.12 results in

$$\begin{aligned} V_1 &= I_1 R_1 = I_s R_1 = (60 \text{ mA})(10 \Omega) = \mathbf{0.6 \text{ V}} \\ V_2 &= I_2 R_2 = I_s R_2 = (60 \text{ mA})(30 \Omega) = \mathbf{1.8 \text{ V}} \\ V_3 &= I_3 R_3 = I_s R_3 = (60 \text{ mA})(100 \Omega) = \mathbf{6.0 \text{ V}} \end{aligned}$$

Note that in all the numerical calculations appearing in the text thus far, a unit of measurement has been applied to each calculated quantity. Always remember that a quantity without a unit of measurement is often meaningless.

**EXAMPLE 5.4** For the series circuit in Fig. 5.15:

- Find the total resistance  $R_T$ .
- Calculate the resulting source current  $I_s$ .
- Determine the voltage across each resistor.

**Solutions:**

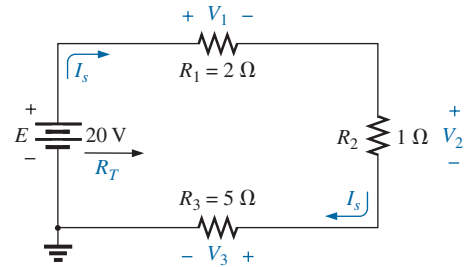
- $$R_T = R_1 + R_2 + R_3$$

$$= 2 \Omega + 1 \Omega + 5 \Omega$$

$$R_T = \mathbf{8 \Omega}$$
- $$I_s = \frac{E}{R_T} = \frac{20 \text{ V}}{8 \Omega} = \mathbf{2.5 \text{ A}}$$
- $$V_1 = I_1 R_1 = I_s R_1 = (2.5 \text{ A})(2 \Omega) = \mathbf{5 \text{ V}}$$

$$V_2 = I_2 R_2 = I_s R_2 = (2.5 \text{ A})(1 \Omega) = \mathbf{2.5 \text{ V}}$$

$$V_3 = I_3 R_3 = I_s R_3 = (2.5 \text{ A})(5 \Omega) = \mathbf{12.5 \text{ V}}$$



**FIG. 5.15**

Series circuit to be investigated in Example 5.4.

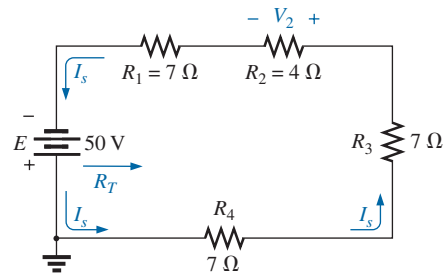
**EXAMPLE 5.5** For the series circuit in Fig. 5.16:

- Find the total resistance  $R_T$ .
- Determine the source current  $I_s$  and indicate its direction on the circuit.
- Find the voltage across resistor  $R_2$  and indicate its polarity on the circuit.

**Solutions:**

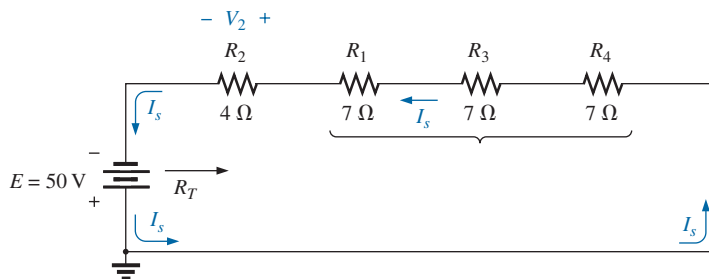
- The elements of the circuit are rearranged as shown in Fig. 5.17.

$$\begin{aligned} R_T &= R_2 + NR \\ &= 4 \Omega + (3)(7 \Omega) \\ &= 4 \Omega + 21 \Omega \\ R_T &= \mathbf{25 \Omega} \end{aligned}$$



**FIG. 5.16**

Series circuit to be analyzed in Example 5.5.



**FIG. 5.17**

Circuit in Fig. 5.16 redrawn to permit the use of Eq. (5.2).

- b. Note that because of the manner in which the dc supply was connected, the current now has a counterclockwise direction as shown in Fig. 5.17.

$$I_s = \frac{E}{R_T} = \frac{50 \text{ V}}{25 \Omega} = 2 \text{ A}$$

- c. The direction of the current will define the polarity for  $V_2$  appearing in Fig. 5.17.

$$V_2 = I_2 R_2 = I_s R_2 = (2 \text{ A})(4 \Omega) = 8 \text{ V}$$

Examples 5.4 and 5.5 are straightforward, substitution-type problems that are relatively easy to solve with some practice. Example 5.6, however, is another type of problem that requires both a firm grasp of the fundamental laws and equations and an ability to identify which quantity should be determined first. The best preparation for this type of exercise is to work through as many problems of this kind as possible.

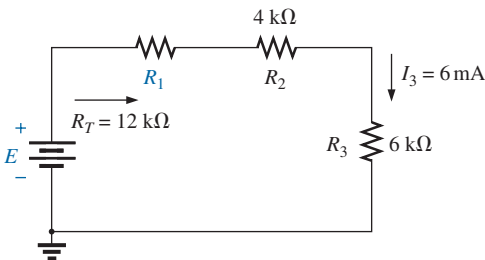


FIG. 5.18

Series circuit to be analyzed in Example 5.6.

**EXAMPLE 5.6** Given  $R_T$  and  $I_3$ , calculate  $R_1$  and  $E$  for the circuit in Fig. 5.18.

**Solution:** Since we are given the total resistance, it seems natural to first write the equation for the total resistance and then insert what we know.

$$R_T = R_1 + R_2 + R_3$$

We find that there is only one unknown, and it can be determined with some simple mathematical manipulations. That is,

$$12 \text{ k}\Omega = R_1 + 4 \text{ k}\Omega + 6 \text{ k}\Omega = R_1 + 10 \text{ k}\Omega$$

and  $12 \text{ k}\Omega - 10 \text{ k}\Omega = R_1$

so that  $R_1 = 2 \text{ k}\Omega$

The dc voltage can be determined directly from Ohm's law.

$$E = I_3 R_T = I_3 R_T = (6 \text{ mA})(12 \text{ k}\Omega) = 72 \text{ V}$$

## Analogies

The analogies used earlier to define the series connection are also excellent for the current of a series circuit. For instance, for the series-connected ropes, the stress on each rope **is the same** as they try to hold the heavy weight. For the water analogy, the flow of water **is the same** through each section of hose as the water is carried to its destination.

## Instrumentation

Another important concept to remember is:

**The insertion of any meter in a circuit will affect the circuit.**

You must use meters that minimize the impact on the response of the circuit. The loading effects of meters are discussed in detail in a later section of this chapter. For now, we will assume that the meters are ideal and do not affect the networks to which they are applied so that we can concentrate on their proper usage.



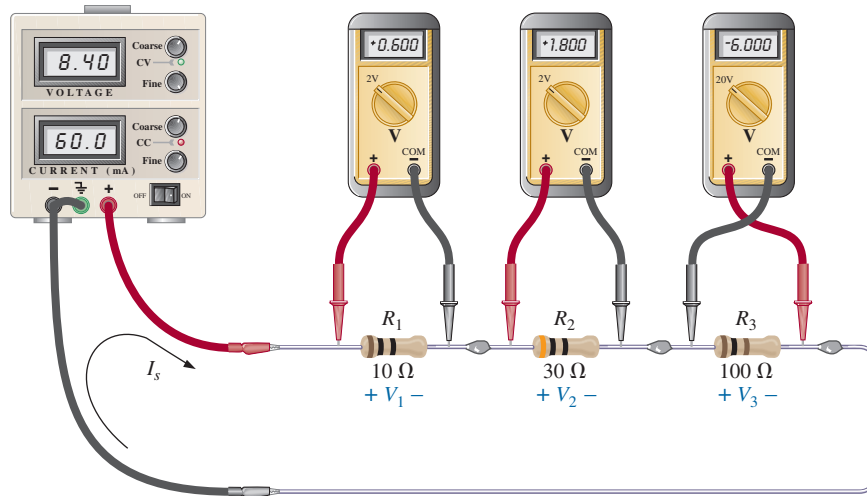


FIG. 5.19

Using voltmeters to measure the voltages across the resistors in Fig. 5.12.

Further, it is particularly helpful in the laboratory to realize that

*the voltages of a circuit can be measured without disturbing (breaking the connections in) the circuit.*

In Fig. 5.19, all the voltages of the circuit in Fig. 5.12 are being measured by voltmeters that were connected without disturbing the original configuration. Note that all the voltmeters are placed **across** the resistive elements. In addition, note that the positive (normally red) lead of the voltmeter is connected to the point of higher potential (positive sign), with the negative (normally black) lead of the voltmeter connected to the point of lower potential (negative sign) for  $V_1$  and  $V_2$ . The result is a positive reading on the display. If the leads were reversed, the magnitude would remain the same, but a negative sign would appear as shown for  $V_3$ .

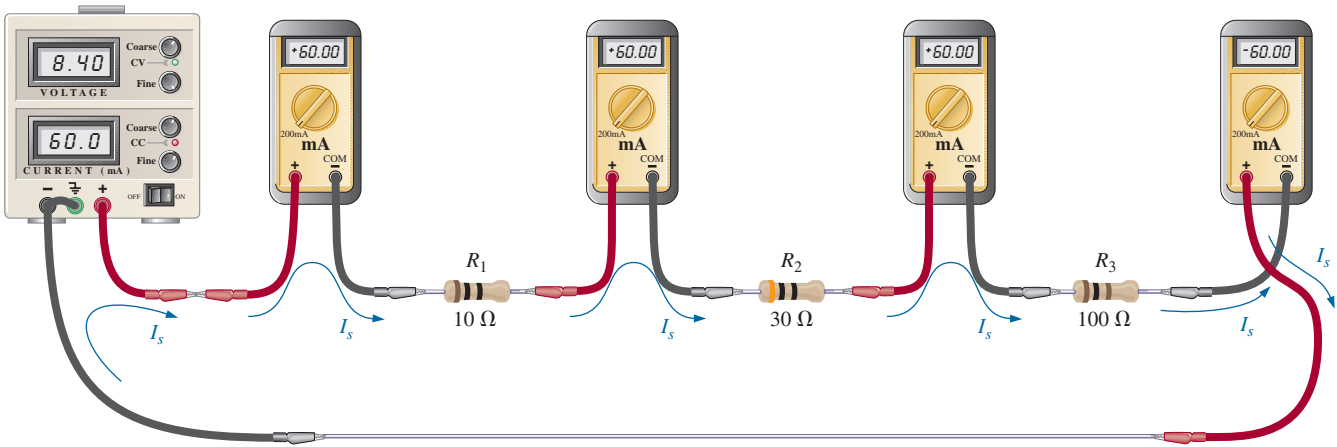
Take special note that the 20 V scale of our meter was used to measure the  $-6$  V level, while the 2 V scale of our meter was used to measure the 0.6 V and 1.8 V levels. The maximum value of the chosen scale must always exceed the maximum value to be measured. In general,

*when using a voltmeter, start with a scale that will ensure that the reading is less than the maximum value of the scale. Then work your way down in scales until the reading with the highest level of precision is obtained.*

Turning our attention to the current of the circuit, we find that

*using an ammeter to measure the current of a circuit requires that the circuit be broken at some point and the meter inserted in series with the branch in which the current is to be determined.*

For instance, to measure the current leaving the positive terminal of the supply, the connection to the positive terminal must be removed to create an open circuit between the supply and resistor  $R_1$ . The ammeter is then inserted between these two points to form a bridge between the supply and the first resistor, as shown in Fig. 5.20. The ammeter is now in series with the supply and the other elements of the circuit. If each meter is to provide a positive reading, the connection must be made such that conventional current enters the positive terminal of the meter and leaves the



**FIG. 5.20**  
Measuring the current throughout the series circuit in Fig. 5.12.

negative terminal. This was done for three of the ammeters, with the ammeter to the right of  $R_3$  connected in the reverse manner. The result is a negative sign for the current. However, also note that the current has the correct magnitude. Since the current is 60 mA, the 200 mA scale of our meter was used for each meter.

As expected, the current at each point in the series circuit is the same using our ideal ammeters.

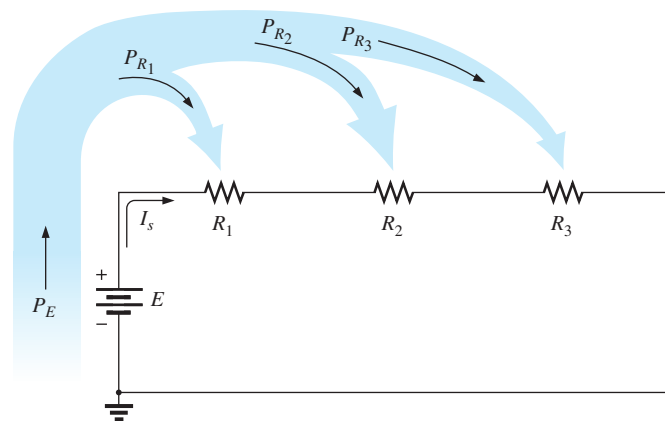
### 5.4 POWER DISTRIBUTION IN A SERIES CIRCUIT

In any electrical system, the power applied will equal the power dissipated or absorbed. For any series circuit, such as that in Fig. 5.21,

*the power applied by the dc supply must equal that dissipated by the resistive elements.*

In equation form,

$$P_E = P_{R_1} + P_{R_2} + P_{R_3} \tag{5.5}$$



**FIG. 5.21**  
Power distribution in a series circuit.

The power delivered by the supply can be determined using

$$P_E = EI_s \quad (\text{watts, W}) \quad (5.6)$$

The power dissipated by the resistive elements can be determined by any of the following forms (shown for resistor  $R_1$  only):

$$P_1 = V_1 I_1 = I_1^2 R_1 = \frac{V_1^2}{R_1} \quad (\text{watts, W}) \quad (5.7)$$

Since the current is the same through series elements, you will find in the following examples that

*in a series configuration, maximum power is delivered to the largest resistor.*

**EXAMPLE 5.7** For the series circuit in Fig. 5.22 (all standard values):

- Determine the total resistance  $R_T$ .
- Calculate the current  $I_s$ .
- Determine the voltage across each resistor.
- Find the power supplied by the battery.
- Determine the power dissipated by each resistor.
- Comment on whether the total power supplied equals the total power dissipated.

**Solutions:**

- $$R_T = R_1 + R_2 + R_3$$

$$= 1 \text{ k}\Omega + 3 \text{ k}\Omega + 2 \text{ k}\Omega$$

$$R_T = \mathbf{6 \text{ k}\Omega}$$
- $$I_s = \frac{E}{R_T} = \frac{36 \text{ V}}{6 \text{ k}\Omega} = \mathbf{6 \text{ mA}}$$
- $$V_1 = I_1 R_1 = I_s R_1 = (6 \text{ mA})(1 \text{ k}\Omega) = \mathbf{6 \text{ V}}$$

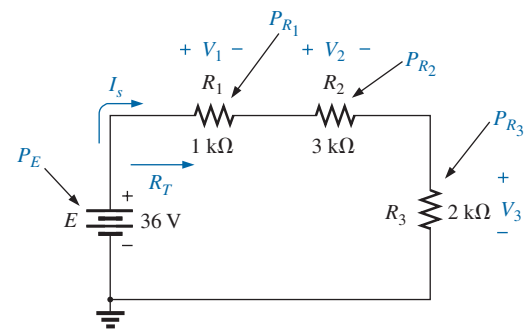
$$V_2 = I_2 R_2 = I_s R_2 = (6 \text{ mA})(3 \text{ k}\Omega) = \mathbf{18 \text{ V}}$$

$$V_3 = I_3 R_3 = I_s R_3 = (6 \text{ mA})(2 \text{ k}\Omega) = \mathbf{12 \text{ V}}$$
- $$P_E = EI_s = (36 \text{ V})(6 \text{ mA}) = \mathbf{216 \text{ mW}}$$
- $$P_1 = V_1 I_1 = (6 \text{ V})(6 \text{ mA}) = \mathbf{36 \text{ mW}}$$

$$P_2 = I_2^2 R_2 = (6 \text{ mA})^2 (3 \text{ k}\Omega) = \mathbf{108 \text{ mW}}$$

$$P_3 = \frac{V_3^2}{R_3} = \frac{(12 \text{ V})^2}{2 \text{ k}\Omega} = \mathbf{72 \text{ mW}}$$
- $$P_E = P_{R_1} + P_{R_2} + P_{R_3}$$

$$216 \text{ mW} = 36 \text{ mW} + 108 \text{ mW} + 72 \text{ mW} = \mathbf{216 \text{ mW}} \quad (\text{checks})$$



**FIG. 5.22**

Series circuit to be investigated in Example 5.7.

## 5.5 VOLTAGE SOURCES IN SERIES

Voltage sources can be connected in series, as shown in Fig. 5.23, to increase or decrease the total voltage applied to a system. The net voltage is determined by summing the sources with the same polarity and subtracting the total of the sources with the opposite polarity. The net polarity is the polarity of the larger sum.

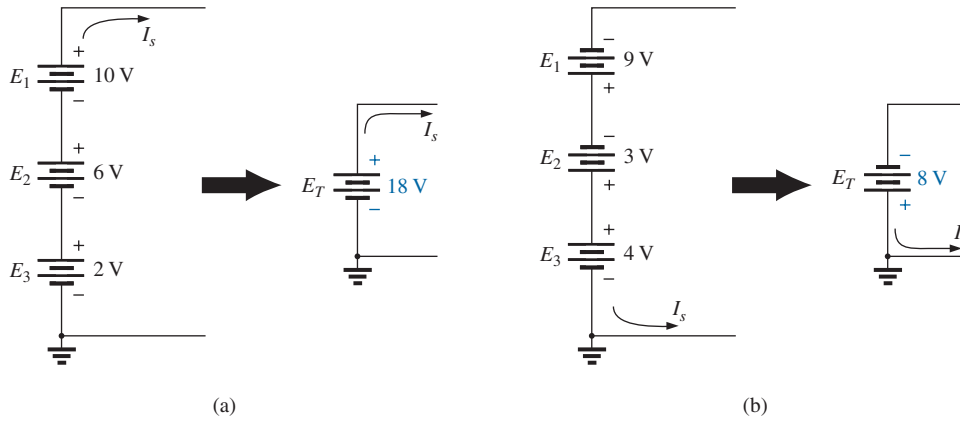


FIG. 5.23

Reducing series dc voltage sources to a single source.

In Fig. 5.23(a), for example, the sources are all “pressuring” current to follow a clockwise path, so the net voltage is

$$E_T = E_1 + E_2 + E_3 = 10\text{ V} + 6\text{ V} + 2\text{ V} = \mathbf{18\text{ V}}$$

as shown in the figure. In Fig. 5.23(b), however, the 4 V source is “pressuring” current in the counterclockwise direction while the other two are trying to establish current in the clockwise direction. In this case, the applied voltage for a counterclockwise direction is greater than that for the clockwise direction. The result is the counterclockwise direction for the current as shown in Fig. 5.23(b). The net effect can be determined by finding the difference in applied voltage between those supplies “pressuring” current in one direction and the total in the other direction. In this case,

$$E_T = E_1 + E_2 - E_3 = 9\text{ V} + 3\text{ V} - 4\text{ V} = \mathbf{8\text{ V}}$$

with the polarity shown in the figure.

## Instrumentation

The connection of batteries in series to obtain a higher voltage is common in much of today’s portable electronic equipment. For example, in Fig. 5.24(a), four 1.5 V AAA batteries have been connected in series to obtain a source voltage of 6 V. Although the voltage has increased, keep in mind that the maximum current for each AAA battery and for the 6 V supply is still the same. However, the power available has increased by a factor of 4 due to the increase in terminal voltage. Note also, as mentioned in Chapter 2, that the negative end of each battery is connected to the spring, and the positive end to the solid contact. In addition, note how the connection is made between batteries using the horizontal connecting tabs.

In general, supplies with only two terminals (+ and -) can be connected as shown for the batteries. A problem arises, however, if the supply has an optional or fixed internal ground connection. In Fig. 5.24(b), two laboratory supplies have been connected in series with both grounds connected. The result is a shorting out of the lower source  $E_1$  (which may damage the supply if the protective fuse does not activate quickly enough) because both grounds are at zero potential. In such cases, the supply  $E_2$  must be left ungrounded (floating), as shown in Fig. 5.24(c), to provide the 60 V terminal voltage. If the laboratory supplies have an internal connection from the negative terminal to ground as a protective

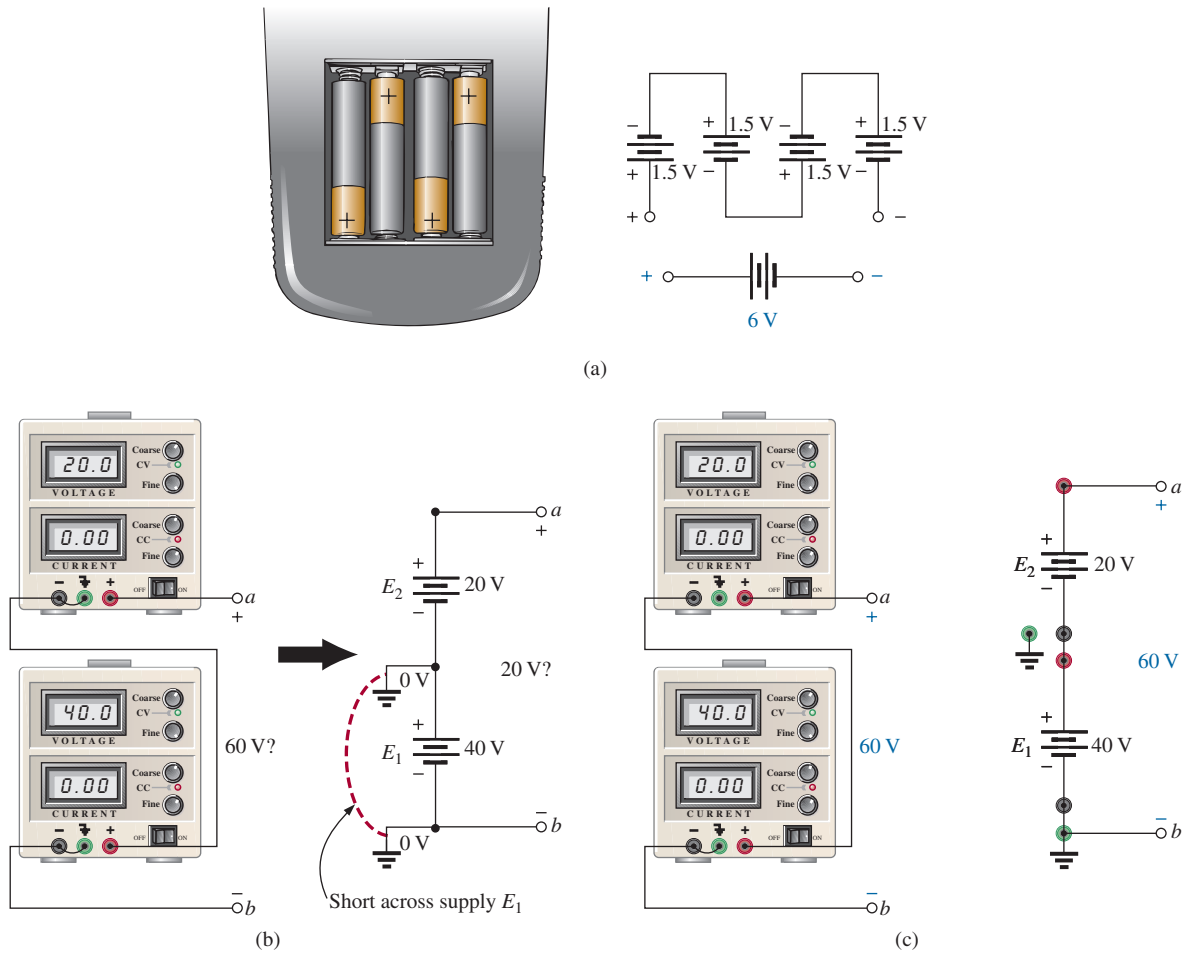


FIG. 5.24

Series connection of dc supplies: (a) four 1.5 V batteries in series to establish a terminal voltage of 6 V; (b) incorrect connections for two series dc supplies; (c) correct connection of two series supplies to establish 60 V at the output terminals.

feature for the users, a series connection of supplies cannot be made. Be aware of this fact, because some educational institutions add an internal ground to the supplies as a protective feature even though the panel still displays the ground connection as an optional feature.

## 5.6 KIRCHHOFF'S VOLTAGE LAW

The law to be described in this section is one of the most important in this field. It has application not only to dc circuits but also to any type of signal—whether it be ac, digital, and so on. This law is far-reaching and can be very helpful in working out solutions to networks that sometimes leave us lost for a direction of investigation.

The law, called **Kirchhoff's voltage law (KVL)**, was developed by Gustav Kirchhoff (Fig. 5.25) in the mid-1800s. It is a cornerstone of the entire field and, in fact, will never be outdated or replaced.

The application of the law requires that we define a closed path of investigation, permitting us to start at one point in the network, travel through the network, and find our way back to the original starting point. The path does not have to be circular, square, or any other defined shape; it must simply provide a way to leave a point and get back to it without leaving the

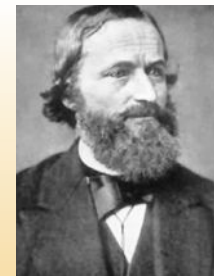
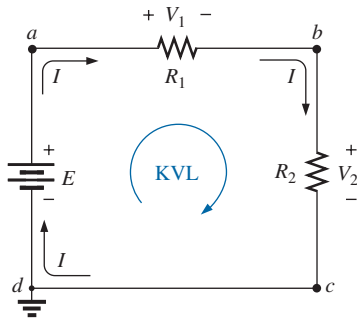


FIG. 5.25

Gustav Robert Kirchhoff.  
Courtesy of the Smithsonian Institution, Photo No. 58,283.

**German** (Königsberg, Berlin) (1824–87),  
**Physicist**  
**Professor of Physics**, University of Heidelberg

Although a contributor to a number of areas in the physics domain, he is best known for his work in the electrical area with his definition of the relationships between the currents and voltages of a network in 1847. Did extensive research with German chemist Robert Bunsen (developed the *Bunsen burner*), resulting in the discovery of the important elements of *cesium and rubidium*.



**FIG. 5.26**

Applying Kirchhoff's voltage law to a series dc circuit.

network. In Fig. 5.26, if we leave point *a* and follow the current, we will end up at point *b*. Continuing, we can pass through points *c* and *d* and eventually return through the voltage source to point *a*, our starting point. The path *abcd* is therefore a closed path, or **closed loop**. The law specifies that

*the algebraic sum of the potential rises and drops around a closed path (or closed loop) is zero.*

In symbolic form it can be written as

$$\sum_{\text{C}} V = 0 \quad (\text{Kirchhoff's voltage law in symbolic form}) \quad (5.8)$$

where  $\Sigma$  represents summation,  $\text{C}$  the closed loop, and *V* the potential drops and rises. The term *algebraic* simply means paying attention to the signs that result in the equations as we add and subtract terms.

The first question that often arises is, Which way should I go around the closed path? Should I always follow the direction of the current? To simplify matters, this text will always try to move in a clockwise direction. By selecting a direction, you eliminate the need to think about which way would be more appropriate. Any direction will work as long as you get back to the starting point.

Another question is, How do I apply a sign to the various voltages as I proceed in a clockwise direction? For a particular voltage, we will assign a positive sign when proceeding from the negative to positive potential—a positive experience such as moving from a negative checking balance to a positive one. The opposite change in potential level results in a negative sign. In Fig. 5.26, as we proceed from point *d* to point *a* across the voltage source, we move from a negative potential (the negative sign) to a positive potential (the positive sign), so a positive sign is given to the source voltage *E*. As we proceed from point *a* to point *b*, we encounter a positive sign followed by a negative sign, so a drop in potential has occurred, and a negative sign is applied. Continuing from *b* to *c*, we encounter another drop in potential, so another negative sign is applied. We then arrive back at the starting point *d*, and the resulting sum is set equal to zero as defined by Eq. (5.8).

Writing out the sequence with the voltages and the signs results in the following:

$$+E - V_1 - V_2 = 0$$

which can be rewritten as  $E = V_1 + V_2$

The result is particularly interesting because it tells us that

*the applied voltage of a series dc circuit will equal the sum of the voltage drops of the circuit.*

Kirchhoff's voltage law can also be written in the following form:

$$\sum_{\text{C}} V_{\text{rises}} = \sum_{\text{C}} V_{\text{drops}} \quad (5.9)$$

revealing that

*the sum of the voltage rises around a closed path will always equal the sum of the voltage drops.*

To demonstrate that the direction that you take around the loop has no effect on the results, let's take the counterclockwise path and compare results. The resulting sequence appears as

$$-E + V_2 + V_1 = 0$$

yielding the same result of  $E = V_1 + V_2$

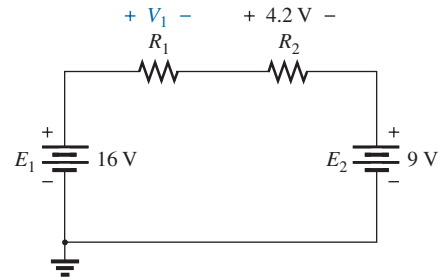
**EXAMPLE 5.8** Use Kirchhoff's voltage law to determine the unknown voltage for the circuit in Fig. 5.27.

**Solution:** When applying Kirchhoff's voltage law, be sure to concentrate on the polarities of the voltage rise or drop rather than on the type of element. In other words, do not treat a voltage drop across a resistive element differently from a voltage rise (or drop) across a source. If the polarity dictates that a drop has occurred, that is the important fact, not whether it is a resistive element or source.

Application of Kirchhoff's voltage law to the circuit in Fig. 5.27 in the clockwise direction results in

$$\begin{aligned}
 &+E_1 - V_1 - V_2 - E_2 = 0 \\
 \text{and} \quad &V_1 = E_1 - V_2 - E_2 \\
 &= 16 \text{ V} - 4.2 \text{ V} - 9 \text{ V} \\
 \text{so} \quad &V_1 = \mathbf{2.8 \text{ V}}
 \end{aligned}$$

The result clearly indicates that you do not need to know the values of the resistors or the current to determine the unknown voltage. Sufficient information was carried by the other voltage levels to determine the unknown.



**FIG. 5.27**

Series circuit to be examined in Example 5.8.

**EXAMPLE 5.9** Determine the unknown voltage for the circuit in Fig. 5.28.

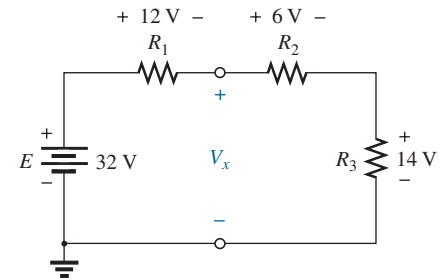
**Solution:** In this case, the unknown voltage is not across a single resistive element but between two arbitrary points in the circuit. Simply apply Kirchhoff's voltage law around a path, including the source or resistor \$R\_3\$. For the clockwise path, including the source, the resulting equation is the following:

$$\begin{aligned}
 &+E - V_1 - V_x = 0 \\
 \text{and} \quad &V_x = E - V_1 = 32 \text{ V} - 12 \text{ V} = \mathbf{20 \text{ V}}
 \end{aligned}$$

For the clockwise path, including resistor \$R\_3\$, the following results:

$$\begin{aligned}
 &+V_x - V_2 - V_3 = 0 \\
 \text{and} \quad &V_x = V_2 + V_3 \\
 &= 6 \text{ V} + 14 \text{ V} \\
 \text{with} \quad &V_x = \mathbf{20 \text{ V}}
 \end{aligned}$$

providing exactly the same solution.



**FIG. 5.28**

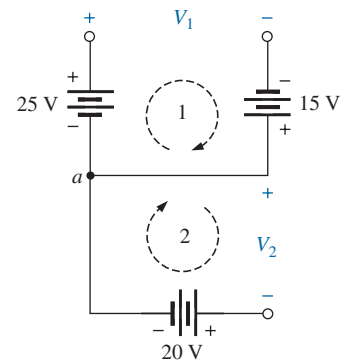
Series dc circuit to be analyzed in Example 5.9.

There is no requirement that the followed path have charge flow or current. In Example 5.10, the current is zero everywhere, but Kirchhoff's voltage law can still be applied to determine the voltage between the points of interest. Also, there will be situations where the actual polarity will not be provided. In such cases, simply assume a polarity. If the answer is negative, the magnitude of the result is correct, but the polarity should be reversed.

**EXAMPLE 5.10** Using Kirchhoff's voltage law, determine voltages \$V\_1\$ and \$V\_2\$ for the network in Fig. 5.29.

**Solution:** For path 1, starting at point \$a\$ in a clockwise direction,

$$\begin{aligned}
 &+25 \text{ V} - V_1 + 15 \text{ V} = 0 \\
 \text{and} \quad &V_1 = \mathbf{40 \text{ V}}
 \end{aligned}$$



**FIG. 5.29**

Combination of voltage sources to be examined in Example 5.10.



For path 2, starting at point *a* in a clockwise direction,

$$-V_2 - 20\text{ V} = 0$$

and

$$V_2 = -20\text{ V}$$

The minus sign in the solution simply indicates that the actual polarities are different from those assumed.

The next example demonstrates that you do not need to know what elements are inside a container when applying Kirchhoff's voltage law. They could all be voltage sources or a mix of sources and resistors. It doesn't matter—simply pay strict attention to the polarities encountered.

Try to find the unknown quantities in the next examples without looking at the solutions. It will help define where you may be having trouble.

Example 5.11 emphasizes the fact that when you are applying Kirchhoff's voltage law, the polarities of the voltage rise or drop are the important parameters, not the type of element involved.

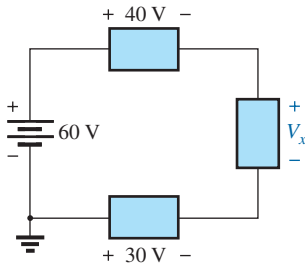


FIG. 5.30

Series configuration to be examined in Example 5.11.

**EXAMPLE 5.11** Using Kirchhoff's voltage law, determine the unknown voltage for the circuit in Fig. 5.30.

**Solution:** Note that in this circuit, there are various polarities across the unknown elements since they can contain any mixture of components. Applying Kirchhoff's voltage law in the clockwise direction results in

$$+60\text{ V} - 40\text{ V} - V_x + 30\text{ V} = 0$$

and

$$V_x = 60\text{ V} + 30\text{ V} - 40\text{ V} = 90\text{ V} - 40\text{ V}$$

with

$$V_x = 50\text{ V}$$

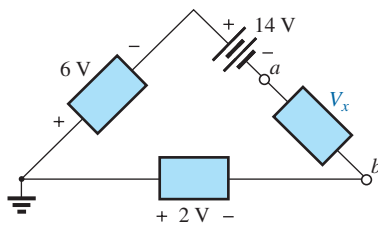


FIG. 5.31

Applying Kirchhoff's voltage law to a circuit in which the polarities have not been provided for one of the voltages (Example 5.12).

**EXAMPLE 5.12** Determine the voltage  $V_x$  for the circuit in Fig. 5.31. Note that the polarity of  $V_x$  was not provided.

**Solution:** For cases where the polarity is not included, simply make an assumption about the polarity, and apply Kirchhoff's voltage law as before. If the result has a positive sign, the assumed polarity was correct. If the result has a minus sign, the **magnitude is correct**, but the assumed polarity must be reversed. In this case, if we assume point *a* to be positive and point *b* to be negative, an application of Kirchhoff's voltage law in the clockwise direction results in

$$-6\text{ V} - 14\text{ V} - V_x + 2\text{ V} = 0$$

and

$$V_x = -20\text{ V} + 2\text{ V}$$

so that

$$V_x = -18\text{ V}$$

Since the result is negative, we know that point *a* should be negative and point *b* should be positive, but the magnitude of 18 V is correct.

**EXAMPLE 5.13** For the series circuit in Fig. 5.32.

- Determine  $V_2$  using Kirchhoff's voltage law.
- Determine current  $I_2$ .
- Find  $R_1$  and  $R_3$ .

**Solution:**

- a. Applying Kirchhoff's voltage law in the clockwise direction starting at the negative terminal of the supply results in

$$-E + V_3 + V_2 + V_1 = 0$$

and  $E = V_1 + V_2 + V_3$  (as expected)

so that  $V_2 = E - V_1 - V_3 = 54 \text{ V} - 18 \text{ V} - 15 \text{ V}$

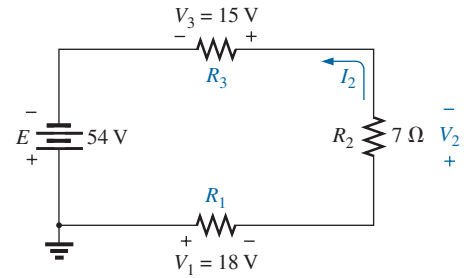
and  $V_2 = 21 \text{ V}$

b.  $I_2 = \frac{V_2}{R_2} = \frac{21 \text{ V}}{7 \Omega}$

$I_2 = 3 \text{ A}$

c.  $R_1 = \frac{V_1}{I_1} = \frac{18 \text{ V}}{3 \text{ A}} = 6 \Omega$

with  $R_3 = \frac{V_3}{I_3} = \frac{15 \text{ V}}{3 \text{ A}} = 5 \Omega$



**FIG. 5.32**

Series configuration to be examined in Example 5.13.

**EXAMPLE 5.14** Using Kirchhoff's voltage law and Fig. 5.12, verify Eq. (5.1).

**Solution:** Applying Kirchhoff's voltage law around the closed path:

$$E = V_1 + V_2 + V_3$$

Substituting Ohm's law:

$$I_s R_T = I_1 R_1 + I_2 R_2 + I_3 R_3$$

but

$$I_s = I_1 = I_2 = I_3$$

so that

$$I_s R_T = I_s (R_1 + R_2 + R_3)$$

and

$$R_T = R_1 + R_2 + R_3$$

which is Eq. (5.1).

### 5.7 VOLTAGE DIVISION IN A SERIES CIRCUIT

The previous section demonstrated that the sum of the voltages across the resistors of a series circuit will always equal the applied voltage. It cannot be more or less than that value. The next question is, How will a resistor's value affect the voltage across the resistor? It turns out that

*the voltage across series resistive elements will divide as the magnitude of the resistance levels.*

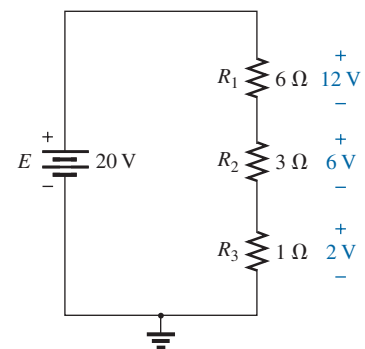
In other words,

*in a series resistive circuit, the larger the resistance, the more of the applied voltage it will capture.*

In addition,

*the ratio of the voltages across series resistors will be the same as the ratio of their resistance levels.*

All of the above statements can best be described by a few simple examples. In Fig. 5.33, all the voltages across the resistive elements are provided. The largest resistor of 6 Ω captures the bulk of the applied voltage, while the smallest resistor, R<sub>3</sub>, has the least. In addition, note that since the resistance level of R<sub>1</sub> is six times that of R<sub>3</sub>, the voltage across R<sub>1</sub> is six times that of R<sub>3</sub>. The fact that the resistance level of R<sub>2</sub> is three times that of R<sub>3</sub>



**FIG. 5.33**

Revealing how the voltage will divide across series resistive elements.

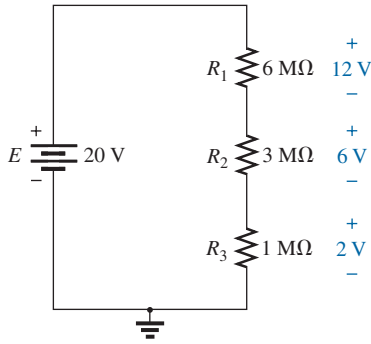


FIG. 5.34

The ratio of the resistive values determines the voltage division of a series dc circuit.

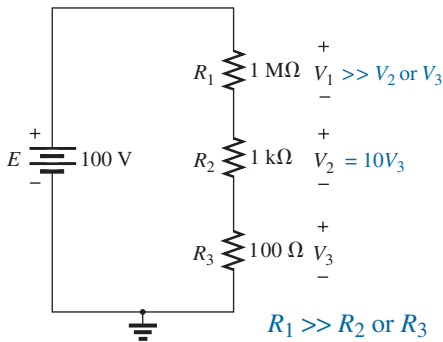


FIG. 5.35

The largest of the series resistive elements will capture the major share of the applied voltage.

results in three times the voltage across  $R_2$ . Finally, since  $R_1$  is twice  $R_2$ , the voltage across  $R_1$  is twice that of  $R_2$ . In general, therefore, the voltage across series resistors will have the same ratio as their resistance levels.

Note that if the resistance levels of all the resistors in Fig. 5.33 are increased by the same amount, as shown in Fig. 5.34, the voltage levels all remain the same. In other words, even though the resistance levels were increased by a factor of 1 million, the voltage ratios remained the same. Clearly, therefore, it is the ratio of resistor values that counts when it comes to voltage division, not the magnitude of the resistors. The current level of the network will be severely affected by this change in resistance level, but the voltage levels remain unaffected.

Based on the above, it should now be clear that when you first encounter a circuit such as that in Fig. 5.35, you will expect that the voltage across the 1 MΩ resistor will be much greater than that across the 1 kΩ or the 100 Ω resistors. In addition, based on a statement above, the voltage across the 1 kΩ resistor will be 10 times as great as that across the 100 Ω resistor since the resistance level is 10 times as much. Certainly, you would expect that very little voltage will be left for the 100 Ω resistor. Note that the current was never mentioned in the above analysis. The distribution of the applied voltage is determined solely by the ratio of the resistance levels. Of course, the magnitude of the resistors will determine the resulting current level.

To continue with the above, since 1 MΩ is 1000 times larger than 1 kΩ, voltage  $V_1$  will be 1000 times larger than  $V_2$ . In addition, voltage  $V_2$  will be 10 times larger than  $V_3$ . Finally, the voltage across the largest resistor of 1 MΩ will be  $(10)(1000) = 10,000$  times larger than  $V_3$ .

Now for some details. The total resistance is

$$\begin{aligned} R_T &= R_1 + R_2 + R_3 \\ &= 1 \text{ M}\Omega + 1 \text{ k}\Omega + 100 \Omega \\ R_T &= \mathbf{1,001,100 \Omega} \end{aligned}$$

The current is

$$I_s = \frac{E}{R_T} = \frac{100 \text{ V}}{1,001,100 \Omega} \cong 99.89 \mu\text{A} \quad (\text{about } 100 \mu\text{A})$$

with

$$\begin{aligned} V_1 &= I_1 R_1 = I_s R_1 = (99.89 \mu\text{A})(1 \text{ M}\Omega) = \mathbf{99.89 \text{ V}} \quad (\text{almost the full } 100 \text{ V}) \\ V_2 &= I_2 R_2 = I_s R_2 = (99.89 \mu\text{A})(1 \text{ k}\Omega) = \mathbf{99.89 \text{ mV}} \quad (\text{about } 100 \text{ mV}) \\ V_3 &= I_3 R_3 = I_s R_3 = (99.89 \mu\text{A})(100 \Omega) = \mathbf{9.989 \text{ mV}} \quad (\text{about } 10 \text{ mV}) \end{aligned}$$

As illustrated above, the major part of the applied voltage is across the 1 MΩ resistor. The current is in the microampere due primarily to the large 1 MΩ resistor. Voltage  $V_2$  is about 0.1 V compared to almost 100 V for  $V_1$ . The voltage across  $R_3$  is only about 10 mV, or 0.010 V.

Before making any detailed, lengthy calculations, you should first examine the resistance levels of the series resistors to develop some idea of how the applied voltage will be divided through the circuit. It will reveal, with a minimum amount of effort, what you should expect when performing the calculations (a checking mechanism). It also allows you to speak intelligently about the response of the circuit without having to resort to any calculations.

### Voltage Divider Rule (VDR)

The **voltage divider rule (VDR)** permits the determination of the voltage across a series resistor without first having to determine the current

of the circuit. The rule itself can be derived by analyzing the simple series circuit in Fig. 5.36.

First, determine the total resistance as follows:

$$R_T = R_1 + R_2$$

Then 
$$I_s = I_1 = I_2 = \frac{E}{R_T}$$

Apply Ohm's law to each resistor:

$$V_1 = I_1 R_1 = \left(\frac{E}{R_T}\right) R_1 = R_1 \frac{E}{R_T}$$

$$V_2 = I_2 R_2 = \left(\frac{E}{R_T}\right) R_2 = R_2 \frac{E}{R_T}$$

The resulting format for  $V_1$  and  $V_2$  is

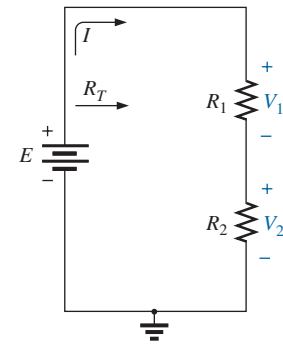
$$\boxed{V_x = R_x \frac{E}{R_T}} \quad (\text{voltage divider rule}) \quad (5.10)$$

where  $V_x$  is the voltage across the resistor  $R_x$ ,  $E$  is the impressed voltage across the series elements, and  $R_T$  is the total resistance of the series circuit.

The voltage divider rule states that

*the voltage across a resistor in a series circuit is equal to the value of that resistor times the total applied voltage divided by the total resistance of the series configuration.*

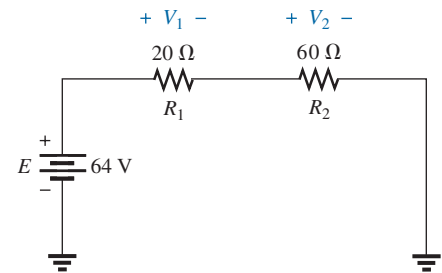
Although Eq. (5.10) was derived using a series circuit of only two elements, it can be used for series circuits with any number of series resistors.



**FIG. 5.36**  
Developing the voltage divider rule.

**EXAMPLE 5.15** For the series circuit in Fig. 5.37.

- Without making any calculations, how much larger would you expect the voltage across  $R_2$  to be compared to that across  $R_1$ ?
- Find the voltage  $V_1$  using only the voltage divider rule.
- Using the conclusion of part (a), determine the voltage across  $R_2$ .
- Use the voltage divider rule to determine the voltage across  $R_2$ , and compare your answer to your conclusion in part (c).
- How does the sum of  $V_1$  and  $V_2$  compare to the applied voltage?



**FIG. 5.37**  
Series circuit to be examined using the voltage divider rule in Example 5.15.

**Solutions:**

- Since resistor  $R_2$  is three times  $R_1$ , it is expected that  $V_2 = 3V_1$ .
- $$V_1 = R_1 \frac{E}{R_T} = 20 \Omega \left( \frac{64 \text{ V}}{20 \Omega + 60 \Omega} \right) = 20 \Omega \left( \frac{64 \text{ V}}{80 \Omega} \right) = 16 \text{ V}$$
- $$V_2 = 3V_1 = 3(16 \text{ V}) = 48 \text{ V}$$
- $$V_2 = R_2 \frac{E}{R_T} = (60 \Omega) \left( \frac{64 \text{ V}}{80 \Omega} \right) = 48 \text{ V}$$

The results are an exact match.

- $$E = V_1 + V_2$$
  
$$64 \text{ V} = 16 \text{ V} + 48 \text{ V} = 64 \text{ V} \quad (\text{checks})$$

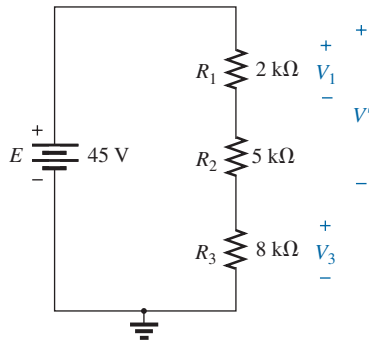


FIG. 5.38

Series circuit to be investigated in Examples 5.16 and 5.17.

**EXAMPLE 5.16** Using the voltage divider rule, determine voltages  $V_1$  and  $V_3$  for the series circuit in Fig. 5.38.

**Solution:**

$$R_T = R_1 + R_2 + R_3 = 2\text{ k}\Omega + 5\text{ k}\Omega + 8\text{ k}\Omega = 15\text{ k}\Omega$$

$$V_1 = R_1 \frac{E}{R_T} = 2\text{ k}\Omega \left( \frac{45\text{ V}}{15\text{ k}\Omega} \right) = 6\text{ V}$$

and

$$V_3 = R_3 \frac{E}{R_T} = 8\text{ k}\Omega \left( \frac{45\text{ V}}{15\text{ k}\Omega} \right) = 24\text{ V}$$

The voltage divider rule can be extended to the voltage across two or more series elements if the resistance in the numerator of Eq. (5.10) is expanded to include the total resistance of the series resistors across which the voltage is to be found ( $R'$ ). That is,

$$V' = R' \frac{E}{R_T} \tag{5.11}$$

**EXAMPLE 5.17** Determine the voltage (denoted  $V'$ ) across the series combination of resistors  $R_1$  and  $R_2$  in Fig. 5.38.

**Solution:** Since the voltage desired is across both  $R_1$  and  $R_2$ , the sum of  $R_1$  and  $R_2$  will be substituted as  $R'$  in Eq. (5.11). The result is

$$R' = R_1 + R_2 = 2\text{ k}\Omega + 5\text{ k}\Omega = 7\text{ k}\Omega$$

and

$$V' = R' \frac{E}{R_T} = 7\text{ k}\Omega \left( \frac{45\text{ V}}{15\text{ k}\Omega} \right) = 21\text{ V}$$

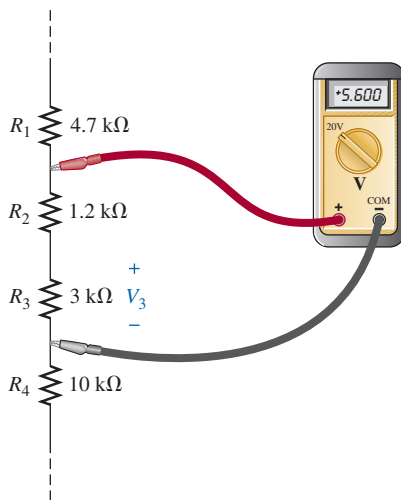


FIG. 5.39

Voltage divider action for Example 5.18.

In the next example you are presented with a problem of the other kind: Given the voltage division, you must determine the required resistor values. In most cases, problems of this kind simply require that you are able to use the basic equations introduced thus far in the text.

**EXAMPLE 5.18** Given the voltmeter reading in Fig. 5.39, find voltage  $V_3$ .

**Solution:** Even though the rest of the network is not shown and the current level has not been determined, the voltage divider rule can be applied by using the voltmeter reading as the full voltage across the series combination of resistors. That is,

$$V_3 = R_3 \frac{(V_{\text{meter}})}{R_3 + R_2} = \frac{3\text{ k}\Omega(5.6\text{ V})}{3\text{ k}\Omega + 1.2\text{ k}\Omega}$$

$$V_3 = 4\text{ V}$$

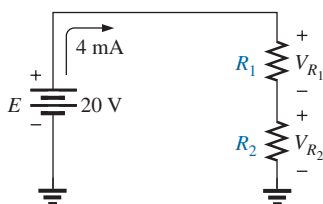


FIG. 5.40

Designing a voltage divider circuit (Example 5.19).

**EXAMPLE 5.19** Design the voltage divider circuit in Fig. 5.40 such that the voltage across  $R_1$  will be four times the voltage across  $R_2$ ; that is,  $V_{R_1} = 4V_{R_2}$ .

**Solution:** The total resistance is defined by

$$R_T = R_1 + R_2$$

However, if  
then  
so that

$$\begin{aligned} V_{R_1} &= 4V_{R_2} \\ R_1 &= 4R_2 \\ R_T = R_1 + R_2 &= 4R_2 + R_2 = 5R_2 \end{aligned}$$

Applying Ohm's law, we can determine the total resistance of the circuit:

$$R_T = \frac{E}{I_s} = \frac{20 \text{ V}}{4 \text{ mA}} = 5 \text{ k}\Omega$$

so

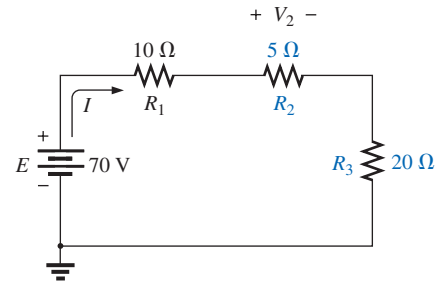
$$R_T = 5R_2 = 5 \text{ k}\Omega$$

and

$$R_2 = \frac{5 \text{ k}\Omega}{5} = 1 \text{ k}\Omega$$

Then

$$R_1 = 4R_2 = 4(1 \text{ k}\Omega) = 4 \text{ k}\Omega$$

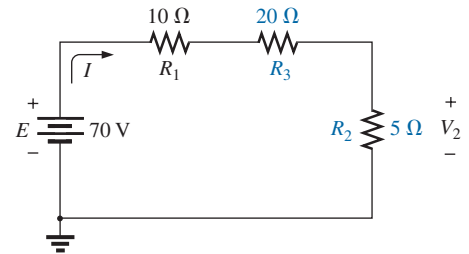


**FIG. 5.41**

Series dc circuit with elements to be interchanged.

### 5.8 INTERCHANGING SERIES ELEMENTS

The elements of a series circuit can be interchanged without affecting the total resistance, current, or power to each element. For instance, the network in Fig. 5.41 can be redrawn as shown in Fig. 5.42 without affecting  $I$  or  $V_2$ . The total resistance  $R_T$  is  $35 \Omega$  in both cases, and  $I = 70 \text{ V}/35 \Omega = 2 \text{ A}$ . The voltage  $V_2 = IR_2 = (2 \text{ A})(5 \Omega) = 10 \text{ V}$  for both configurations.



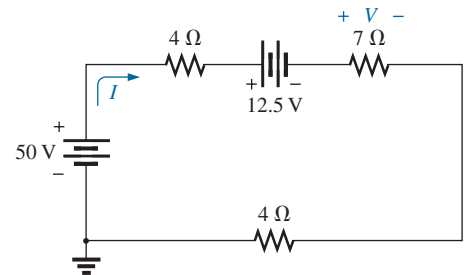
**FIG. 5.42**

Circuit in Fig. 5.41 with  $R_2$  and  $R_3$  interchanged.

**EXAMPLE 5.20** Determine  $I$  and the voltage across the  $7 \Omega$  resistor for the network in Fig. 5.43.

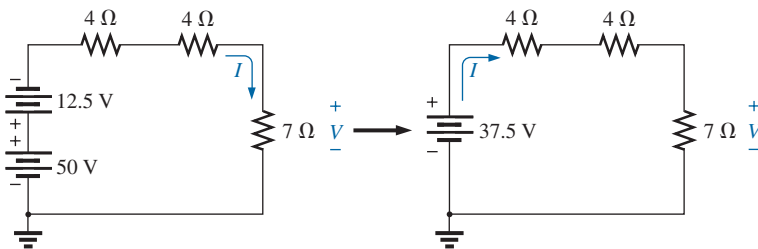
**Solution:** The network is redrawn in Fig. 5.44.

$$\begin{aligned} R_T &= (2)(4 \Omega) + 7 \Omega = 15 \Omega \\ I &= \frac{E}{R_T} = \frac{37.5 \text{ V}}{15 \Omega} = 2.5 \text{ A} \\ V_{7\Omega} &= IR = (2.5 \text{ A})(7 \Omega) = 17.5 \text{ V} \end{aligned}$$



**FIG. 5.43**

Example 5.20.



**FIG. 5.44**

Redrawing the circuit in Fig. 5.43.

### 5.9 NOTATION

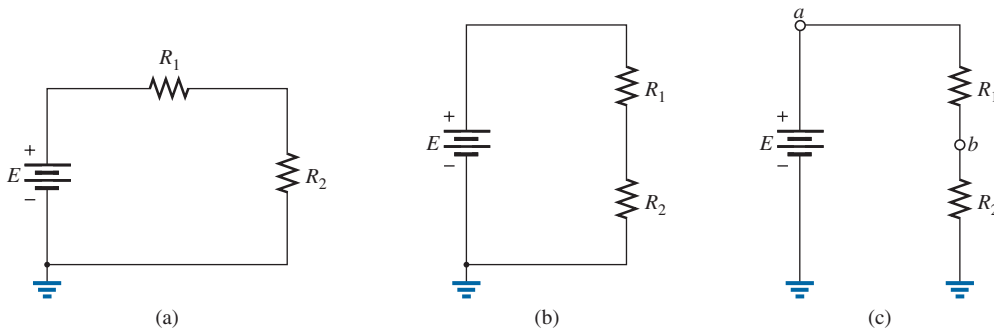
Notation plays an increasingly important role in the analysis to follow. It is important, therefore, that we begin to examine the notation used throughout the industry.



**FIG. 5.45**  
Ground potential.

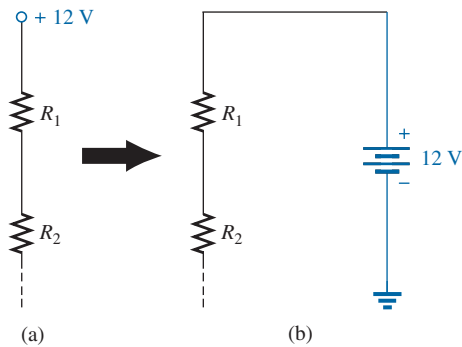
### Voltage Sources and Ground

Except for a few special cases, electrical and electronic systems are grounded for reference and safety purposes. The symbol for the ground connection appears in Fig. 5.45 with its defined potential level—zero volts. A grounded circuit may appear as shown in Fig. 5.46(a), (b), or (c). In any case, it is understood that the negative terminal of the battery and the bottom of the resistor  $R_2$  are at ground potential. Although Fig. 5.46(c) shows no connection between the two grounds, it is recognized that such a connection exists for the continuous flow of charge. If  $E = 12\text{ V}$ , then point  $a$  is  $12\text{ V}$  positive with respect to ground potential, and  $12\text{ V}$  exist across the series combination of resistors  $R_1$  and  $R_2$ . If a voltmeter placed from point  $b$  to ground reads  $4\text{ V}$ , then the voltage across  $R_2$  is  $4\text{ V}$ , with the higher potential at point  $b$ .



**FIG. 5.46**

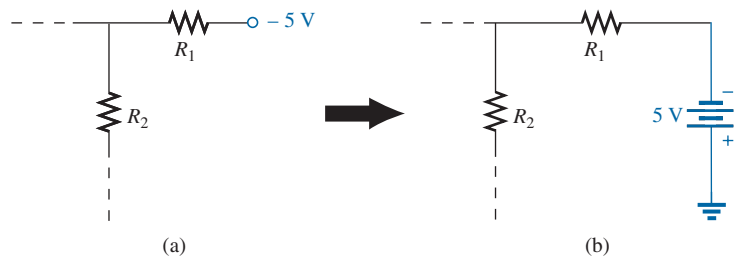
Three ways to sketch the same series dc circuit.



**FIG. 5.47**

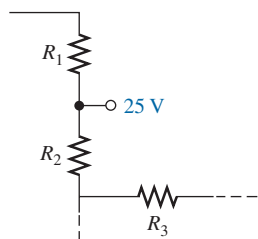
Replacing the special notation for a dc voltage source with the standard symbol.

On large schematics where space is at a premium and clarity is important, voltage sources may be indicated as shown in Figs. 5.47(a) and 5.48(a) rather than as illustrated in Figs. 5.47(b) and 5.48(b). In addition, potential levels may be indicated as in Fig. 5.49, to permit a rapid check of the potential levels at various points in a network with respect to ground to ensure that the system is operating properly.



**FIG. 5.48**

Replacing the notation for a negative dc supply with the standard notation.



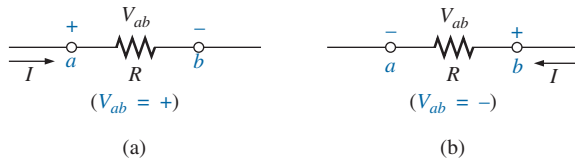
**FIG. 5.49**

The expected voltage level at a particular point in a network if the system is functioning properly.

### Double-Subscript Notation

The fact that voltage is an *across* variable and exists between two points has resulted in a double-subscript notation that defines the first subscript as the higher potential. In Fig. 5.50(a), the two points that define the voltage across the resistor  $R$  are denoted by  $a$  and  $b$ . Since  $a$  is the first subscript for  $V_{ab}$ , point  $a$  must have a higher potential than point  $b$  if  $V_{ab}$  is to have a positive value. If, in fact, point  $b$  is at a higher poten-





**FIG. 5.50**

Defining the sign for double-subscript notation.

tial than point  $a$ ,  $V_{ab}$  will have a negative value, as indicated in Fig. 5.50(b).

In summary:

*The double-subscript notation  $V_{ab}$  specifies point  $a$  as the higher potential. If this is not the case, a negative sign must be associated with the magnitude of  $V_{ab}$ .*

In other words,

*the voltage  $V_{ab}$  is the voltage at point  $a$  with respect to (w.r.t.) point  $b$ .*

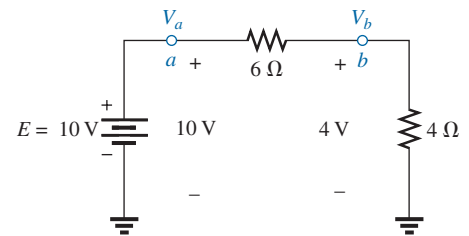
### Single-Subscript Notation

If point  $b$  of the notation  $V_{ab}$  is specified as ground potential (zero volts), then a single-subscript notation can be used that provides the voltage at a point with respect to ground.

In Fig. 5.51,  $V_a$  is the voltage from point  $a$  to ground. In this case, it is obviously 10 V since it is right across the source voltage  $E$ . The voltage  $V_b$  is the voltage from point  $b$  to ground. Because it is directly across the 4 Ω resistor,  $V_b = 4$  V.

In summary:

*The single-subscript notation  $V_a$  specifies the voltage at point  $a$  with respect to ground (zero volts). If the voltage is less than zero volts, a negative sign must be associated with the magnitude of  $V_a$ .*



**FIG. 5.51**

Defining the use of single-subscript notation for voltage levels.

### General Comments

A particularly useful relationship can now be established that has extensive applications in the analysis of electronic circuits. For the above notational standards, the following relationship exists:

$$V_{ab} = V_a - V_b \quad (5.12)$$

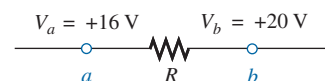
In other words, if the voltage at points  $a$  and  $b$  is known with respect to ground, then the voltage  $V_{ab}$  can be determined using Eq. (5.12). In Fig. 5.51, for example,

$$\begin{aligned} V_{ab} &= V_a - V_b = 10 \text{ V} - 4 \text{ V} \\ &= 6 \text{ V} \end{aligned}$$

**EXAMPLE 5.21** Find the voltage  $V_{ab}$  for the conditions in Fig. 5.52.

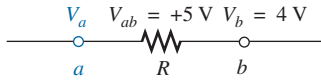
**Solution:** Applying Eq. (5.12):

$$\begin{aligned} V_{ab} &= V_a - V_b = 16 \text{ V} - 20 \text{ V} \\ &= -4 \text{ V} \end{aligned}$$

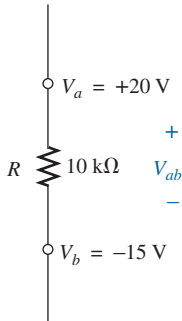


**FIG. 5.52**

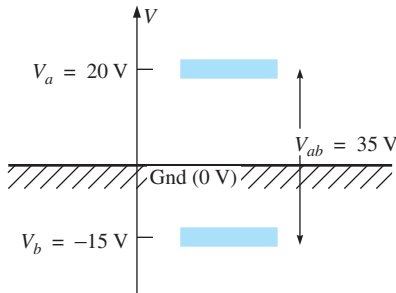
Example 5.21.



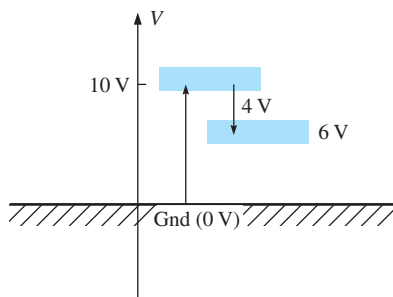
**FIG. 5.53**  
Example 5.22.



**FIG. 5.54**  
Example 5.23.



**FIG. 5.55**  
The impact of positive and negative voltages on the total voltage drop.



**FIG. 5.57**  
Determining  $V_b$  using the defined voltage levels.

Note the negative sign to reflect the fact that point  $b$  is at a higher potential than point  $a$ .

**EXAMPLE 5.22** Find the voltage  $V_a$  for the configuration in Fig. 5.53.

**Solution:** Applying Eq. (5.12):

$$V_{ab} = V_a - V_b$$

and

$$V_a = V_{ab} + V_b = 5 \text{ V} + 4 \text{ V} = \mathbf{9 \text{ V}}$$

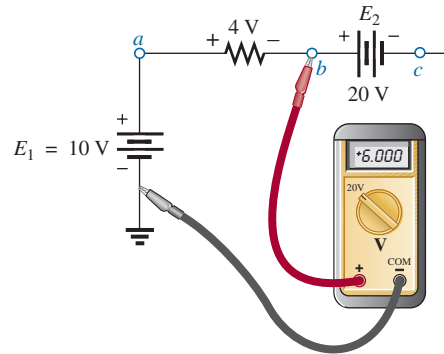
**EXAMPLE 5.23** Find the voltage  $V_{ab}$  for the configuration in Fig. 5.54.

**Solution:** Applying Eq. (5.12):

$$V_{ab} = V_a - V_b = 20 \text{ V} - (-15 \text{ V}) = 20 \text{ V} + 15 \text{ V} = \mathbf{35 \text{ V}}$$

Note in Example 5.23 you must be careful with the signs when applying the equation. The voltage is dropping from a high level of +20 V to a negative voltage of -15 V. As shown in Fig. 5.55, this represents a drop in voltage of 35 V. In some ways it's like going from a positive checking balance of \$20 to owing \$15; the total expenditure is \$35.

**EXAMPLE 5.24** Find the voltages  $V_b$ ,  $V_c$ , and  $V_{ac}$  for the network in Fig. 5.56.



**FIG. 5.56**  
Example 5.24.

**Solution:** Starting at ground potential (zero volts), we proceed through a rise of 10 V to reach point  $a$  and then pass through a drop in potential of 4 V to point  $b$ . The result is that the meter reads

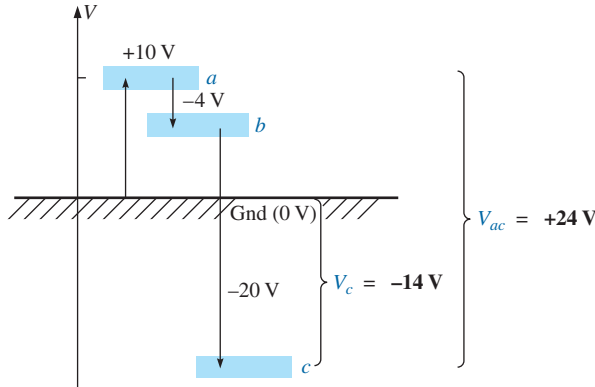
$$V_b = +10 \text{ V} - 4 \text{ V} = \mathbf{6 \text{ V}}$$

as clearly demonstrated by Fig. 5.57.

If we then proceed to point  $c$ , there is an additional drop of 20 V, resulting in

$$V_c = V_b - 20 \text{ V} = 6 \text{ V} - 20 \text{ V} = \mathbf{-14 \text{ V}}$$

as shown in Fig. 5.58.



**FIG. 5.58**

Review of the potential levels for the circuit in Fig. 5.56.

The voltage  $V_{ac}$  can be obtained using Eq. (5.12) or by simply referring to Fig. 5.58.

$$\begin{aligned} V_{ac} &= V_a - V_c = 10 \text{ V} - (-14 \text{ V}) \\ &= \mathbf{24 \text{ V}} \end{aligned}$$

**EXAMPLE 5.25** Determine  $V_{ab}$ ,  $V_{cb}$ , and  $V_c$  for the network in Fig. 5.59.

**Solution:** There are two ways to approach this problem. The first is to sketch the diagram in Fig. 5.60 and note that there is a 54 V drop across the series resistors  $R_1$  and  $R_2$ . The current can then be determined using Ohm's law and the voltage levels as follows:

$$\begin{aligned} I &= \frac{54 \text{ V}}{45 \Omega} = 1.2 \text{ A} \\ V_{ab} &= IR_2 = (1.2 \text{ A})(25 \Omega) = \mathbf{30 \text{ V}} \\ V_{cb} &= -IR_1 = -(1.2 \text{ A})(20 \Omega) = \mathbf{-24 \text{ V}} \\ V_c &= E_1 = \mathbf{-19 \text{ V}} \end{aligned}$$

The other approach is to redraw the network as shown in Fig. 5.61 to clearly establish the aiding effect of  $E_1$  and  $E_2$  and then solve the resulting series circuit.

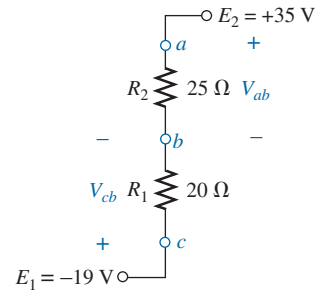
$$I = \frac{E_1 + E_2}{R_T} = \frac{19 \text{ V} + 35 \text{ V}}{45 \Omega} = \frac{54 \text{ V}}{45 \Omega} = 1.2 \text{ A}$$

and  $V_{ab} = \mathbf{30 \text{ V}}$      $V_{cb} = \mathbf{-24 \text{ V}}$      $V_c = \mathbf{-19 \text{ V}}$

**EXAMPLE 5.26** Using the voltage divider rule, determine the voltages  $V_1$  and  $V_2$  of Fig. 5.62.

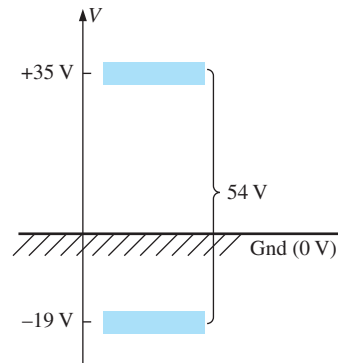
**Solution:** Redrawing the network with the standard battery symbol results in the network in Fig. 5.63. Applying the voltage divider rule,

$$\begin{aligned} V_1 &= \frac{R_1 E}{R_1 + R_2} = \frac{(4 \Omega)(24 \text{ V})}{4 \Omega + 2 \Omega} = \mathbf{16 \text{ V}} \\ V_2 &= \frac{R_2 E}{R_1 + R_2} = \frac{(2 \Omega)(24 \text{ V})}{4 \Omega + 2 \Omega} = \mathbf{8 \text{ V}} \end{aligned}$$



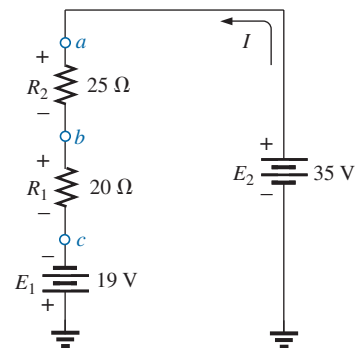
**FIG. 5.59**

Example 5.25.



**FIG. 5.60**

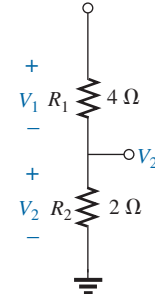
Determining the total voltage drop across the resistive elements in Fig 5.59.



**FIG. 5.61**

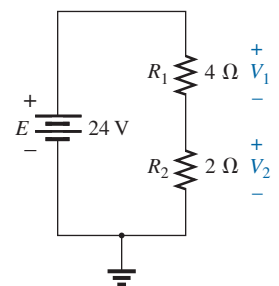
Redrawing the circuit in Fig. 5.59 using standard dc voltage supply symbols.

$E = +24 \text{ V}$



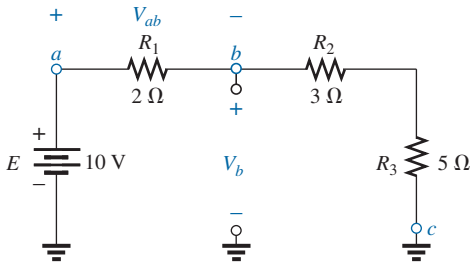
**FIG. 5.62**

Example 5.26.



**FIG. 5.63**

Circuit of Fig. 5.62 redrawn.



**FIG. 5.64**  
Example 5.27.

**EXAMPLE 5.27** For the network in Fig. 5.64.

- Calculate  $V_{ab}$ .
- Determine  $V_b$ .
- Calculate  $V_c$ .

**Solutions:**

- Voltage divider rule:

$$V_{ab} = \frac{R_1 E}{R_T} = \frac{(2\ \Omega)(10\ \text{V})}{2\ \Omega + 3\ \Omega + 5\ \Omega} = +2\ \text{V}$$

- Voltage divider rule:

$$V_b = V_{R_2} + V_{R_3} = \frac{(R_2 + R_3)E}{R_T} = \frac{(3\ \Omega + 5\ \Omega)(10\ \text{V})}{10\ \Omega} = 8\ \text{V}$$

or  $V_b = V_a - V_{ab} = E - V_{ab} = 10\ \text{V} - 2\ \text{V} = 8\ \text{V}$

- $V_c = \text{ground potential} = 0\ \text{V}$

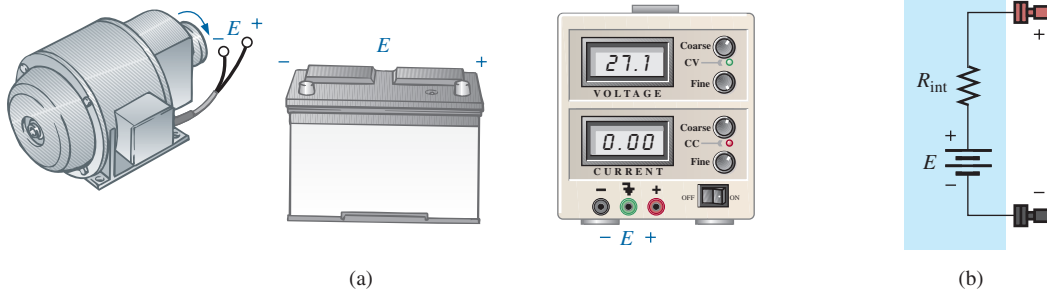
### 5.10 VOLTAGE REGULATION AND THE INTERNAL RESISTANCE OF VOLTAGE SOURCES

When you use a dc supply such as the generator, battery or supply in Fig. 5.65, you initially assume that it will provide the desired voltage for any resistive load you may hook up to the supply. In other words, if the battery is labeled 1.5 V or the supply is set at 20 V, you assume that they will provide that voltage no matter what load we may apply. Unfortunately, this is not always the case. For instance, if we apply a 1 kΩ resistor to a dc laboratory supply, it is fairly easy to set the voltage across the resistor to 20 V. However, if we remove the 1 kΩ resistor and replace it with a 100 Ω resistor and don't touch the controls on the supply at all, we may find that the voltage has dropped to 19.14 V. Change the load to a 68 Ω resistor, and the terminal voltage drops to 18.72 V. We discover that the load applied affects the terminal voltage of the supply. In fact, this example points out that

*a network should always be connected to a supply before the level of supply voltage is set.*

The reason the terminal voltage drops with changes in load (current demand) is that

*every practical (real-world) supply has an internal resistance in series with the idealized voltage source*



**FIG. 5.65**  
(a) Sources of dc voltage; (b) equivalent circuit.

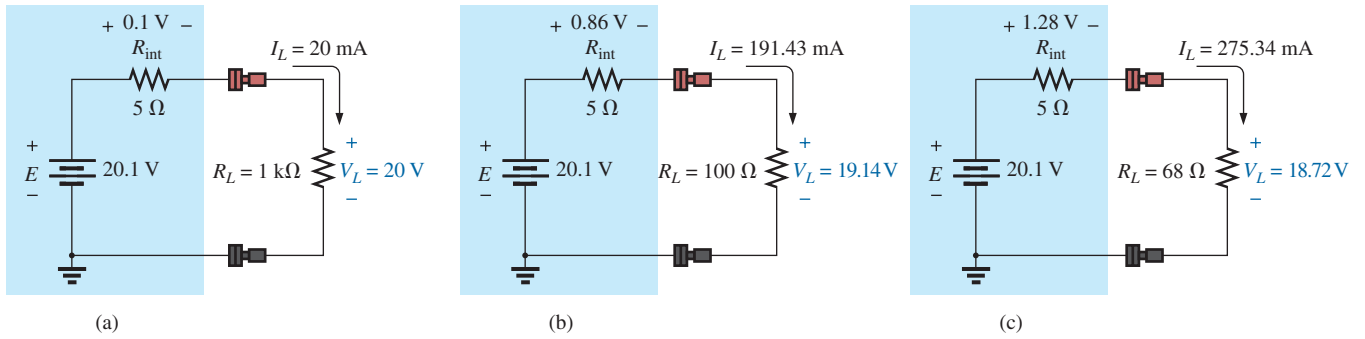


FIG. 5.66

Demonstrating the effect of changing a load on the terminal voltage of a supply.

as shown in Fig. 5.65(b). The resistance level depends on the type of supply, but it is always present. Every year new supplies come out that are less sensitive to the load applied, but even so, some sensitivity still remains.

The supply in Fig. 5.66 helps explain the action that occurred above as we changed the load resistor. Due to the **internal resistance** of the supply, the ideal internal supply must be set to 20.1 V in Fig. 5.66(a) if 20 V are to appear across the 1 k $\Omega$  resistor. The internal resistance will capture 0.1 V of the applied voltage. The current in the circuit is determined by simply looking at the load and using Ohm's law; that is,  $I_L = V_L/R_L = 20\text{ V}/1\text{ k}\Omega = 20\text{ mA}$ , which is a relatively low current.

In Fig. 5.66(b), all the settings of the supply are left untouched, but the 1 k $\Omega$  load is replaced by a 100  $\Omega$  resistor. The resulting current is now  $I_L = E/R_T = 20.1\text{ V}/105\ \Omega = 191.43\text{ mA}$ , and the output voltage is  $V_L = I_L R = (191.43\text{ mA})(100\ \Omega) = 19.14\text{ V}$ , a drop of 0.86 V. In Fig. 5.66(c), a 68  $\Omega$  load is applied, and the current increases substantially to 275.34 mA with a terminal voltage of only 18.72 V. This is a drop of 1.28 V from the expected level. Quite obviously, therefore, as the current drawn from the supply increases, the terminal voltage continues to drop.

If we plot the terminal voltage versus current demand from 0 A to 275.34 mA, we obtain the plot in Fig. 5.67. Interestingly enough, it turns out to be a straight line that continues to drop with an increase in current demand. Note, in particular, that the curve begins at a current level of 0 A. Under no-load conditions, where the output terminals of the supply are

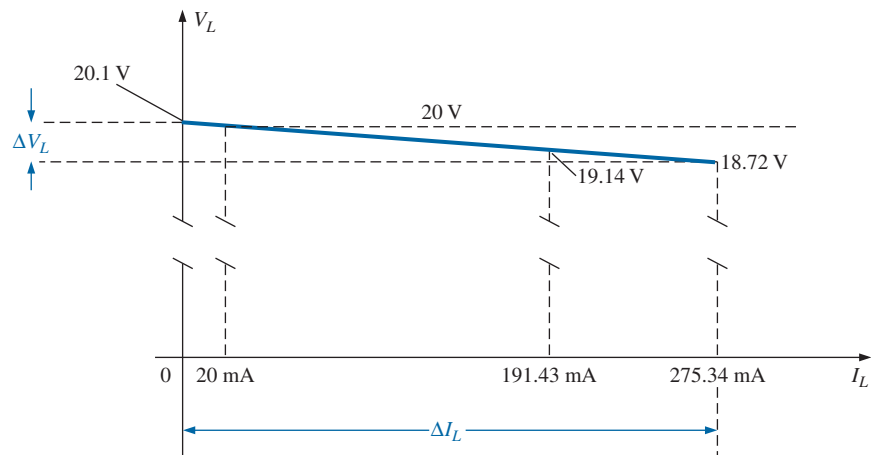


FIG. 5.67

Plotting  $V_L$  versus  $I_L$  for the supply in Fig. 5.66.

not connected to any load, the current will be 0 A due to the absence of a complete circuit. The output voltage will be the internal ideal supply level of 20.1 V.

The slope of the line is defined by the internal resistance of the supply. That is,

$$R_{\text{int}} = \frac{\Delta V_L}{\Delta I_L} \quad (\text{ohms, } \Omega) \quad (5.13)$$

which for the plot in Fig. 5.67 results in

$$R_{\text{int}} = \frac{\Delta V_L}{\Delta I_L} = \frac{20.1 \text{ V} - 18.72 \text{ V}}{275.34 \text{ mA} - 0 \text{ mA}} = \frac{1.38 \text{ V}}{275.34 \text{ mA}} = 5 \Omega$$

For supplies of any kind, the plot of particular importance is the output voltage versus current drawn from the supply, as shown in Fig. 5.68(a). Note that the maximum value is achieved under no-load (NL) conditions as defined by Fig. 5.68(b) and the description above. Full-load (FL) conditions are defined by the maximum current the supply can provide on a continuous basis, as shown in Fig. 5.68(c).

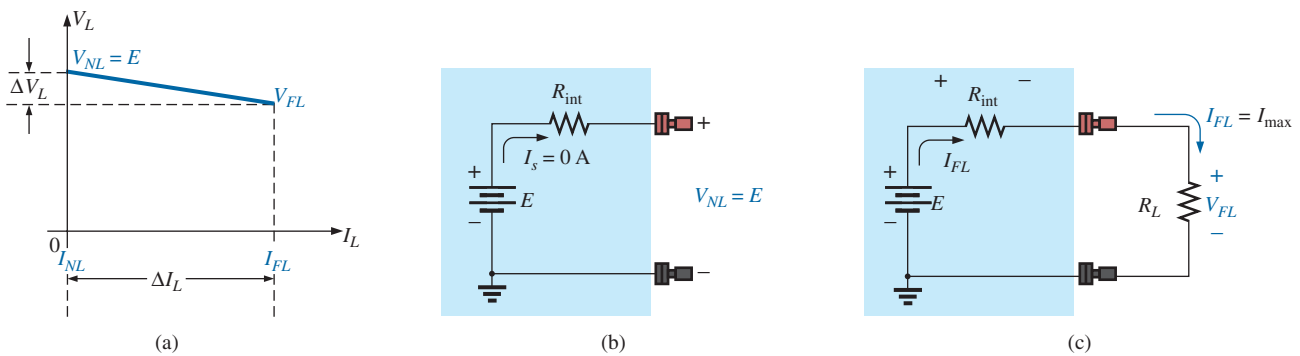


FIG. 5.68

Defining the properties of importance for a power supply.

As a basis for comparison, an ideal power supply and its response curve are provided in Fig. 5.69. Note the absence of the internal resistance and the fact that the plot is a horizontal line (no variation at all with load demand)—an impossible response curve. When we compare the

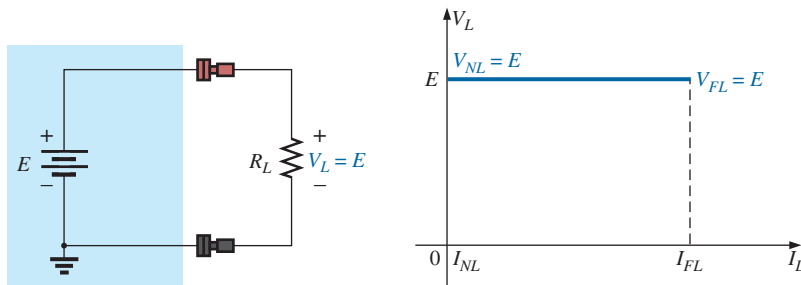


FIG. 5.69

Ideal supply and its terminal characteristics.

curve in Fig. 5.69 with that in Fig. 5.68(a), however, we now realize that the *steeper the slope*, the more sensitive the supply is to the change in load and therefore the *less desirable* it is for many laboratory procedures. In fact,

***the larger the internal resistance, the steeper the drop in voltage with an increase in load demand (current).***

To help us anticipate the expected response of a supply, a defining quantity called **voltage regulation** (abbreviated VR; often called *load regulation* on specification sheets) was established. The basic equation in terms of the quantities in Fig. 5.68(a) is the following:

$$VR = \frac{V_{NL} - V_{FL}}{V_{FL}} \times 100\% \quad (5.14)$$

The examples to follow demonstrate that

***the smaller the voltage or load regulation of a supply, the less the terminal voltage will change with increasing levels of current demand.***

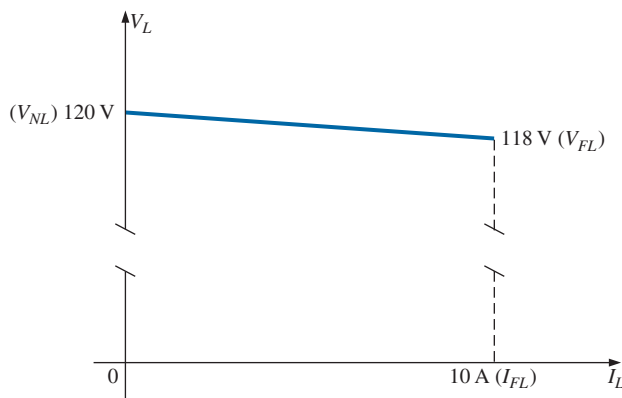
For the supply above with a no-load voltage of 20.1 V and a full-load voltage of 18.72 V, at 275.34 mA the voltage regulation is

$$VR = \frac{V_{NL} - V_{FL}}{V_{FL}} \times 100\% = \frac{20.1 \text{ V} - 18.72 \text{ V}}{18.72 \text{ V}} \times 100\% \cong 7.37\%$$

which is quite high, revealing that we have a very sensitive supply. Most modern commercial supplies have regulation factors less than 1%, with 0.01% being very typical.

### EXAMPLE 5.28

- Given the characteristics in Fig. 5.70, determine the voltage regulation of the supply.
- Determine the internal resistance of the supply.
- Sketch the equivalent circuit for the supply.



**FIG. 5.70**

Terminal characteristics for the supply of Example 5.28.



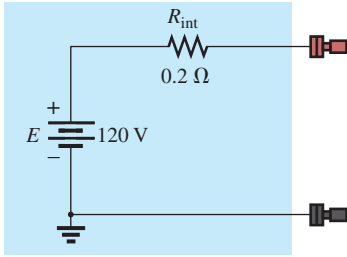


FIG. 5.71

dc supply with the terminal characteristics of Fig. 5.70.

**Solutions:**

- a.  $VR = \frac{V_{NL} - V_{FL}}{V_{FL}} \times 100\%$   
 $= \frac{120\text{ V} - 118\text{ V}}{118\text{ V}} \times 100\% = \frac{2}{118} \times 100\%$   
 $VR \cong 1.7\%$
- b.  $R_{int} = \frac{\Delta V_L}{\Delta I_L} = \frac{120\text{ V} - 118\text{ V}}{10\text{ A} - 0\text{ A}} = \frac{2\text{ V}}{10\text{ A}} = 0.2\ \Omega$
- c. See Fig. 5.71.

**EXAMPLE 5.29** Given a 60 V supply with a voltage regulation of 2%:

- a. Determine the terminal voltage of the supply under full-load conditions.
- b. If the half-load current is 5 A, determine the internal resistance of the supply.
- c. Sketch the curve of the terminal voltage versus load demand and the equivalent circuit for the supply.

**Solutions:**

- a.  $VR = \frac{V_{NL} - V_{FL}}{V_{FL}} \times 100\%$   
 $2\% = \frac{60\text{ V} - V_{FL}}{V_{FL}} \times 100\%$   
 $\frac{2\%}{100\%} = \frac{60\text{ V} - V_{FL}}{V_{FL}}$   
 $0.02V_{FL} = 60\text{ V} - V_{FL}$   
 $1.02V_{FL} = 60\text{ V}$   
 $V_{FL} = \frac{60\text{ V}}{1.02} = 58.82\text{ V}$
- b.  $I_{FL} = 10\text{ A}$   
 $R_{int} = \frac{\Delta V_L}{\Delta I_L} = \frac{60\text{ V} - 58.82\text{ V}}{10\text{ A} - 0\text{ A}} = \frac{1.18\text{ V}}{10\text{ A}} \cong 0.12\ \Omega$
- c. See Fig. 5.72.

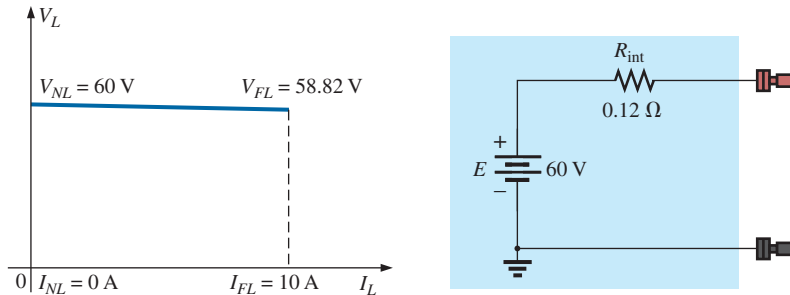


FIG. 5.72

Characteristics and equivalent circuit for the supply of Example 5.29.

## 5.11 LOADING EFFECTS OF INSTRUMENTS

In the previous section, we learned that power supplies are not the ideal instruments we may have thought they were. The applied load can have an effect on the terminal voltage. Fortunately, since today's supplies have such small load regulation factors, the change in terminal voltage with load can usually be ignored for most applications. If we now turn our attention to the various meters we use in the lab, we again find that they are not totally ideal:

*Whenever you apply a meter to a circuit, you change the circuit and the response of the system. Fortunately, however, for most applications, considering the meters to be ideal is a valid approximation as long as certain factors are considered.*

For instance,

*any ammeter connected in a series circuit will introduce resistance to the series combination that will affect the current and voltages of the configuration.*

The resistance between the terminals of an ammeter is determined by the chosen scale of the ammeter. In general,

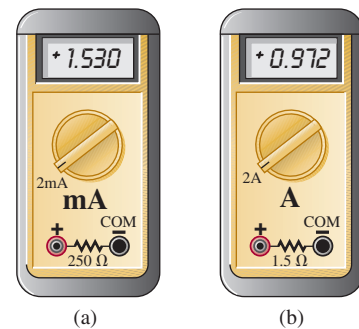
*for ammeters, the higher the maximum value of the current for a particular scale, the smaller the internal resistance will be.*

For example, it is not uncommon for the resistance between the terminals of an ammeter to be  $250\ \Omega$  for a 2 mA scale but only  $1.5\ \Omega$  for the 2 A scale, as shown in Fig. 5.73(a) and (b). If analyzing a circuit in detail, you can include the internal resistance as shown in Fig. 5.73 as a resistor between the two terminals of the meter.

At first reading, such resistance levels at low currents give the impression that ammeters are far from ideal, that they should be used only to obtain a general idea of the current and should not be expected to provide a true reading. Fortunately, however, when you are reading currents below the 2 mA range, the resistors in series with the ammeter are typically in the kilohm range. For example, in Fig. 5.74(a), using an ideal ammeter, the current displayed is 0.6 mA as determined from  $I_s = E/R_T = 12\text{ V}/20\text{ k}\Omega = 0.6\text{ mA}$ . If we now insert a meter with an internal resistance of  $250\ \Omega$  as shown in Fig. 5.74(b), the additional resistance in the circuit will drop the current to 0.593 mA as determined from  $I_s = E/R_T = 12\text{ V}/20.25\text{ k}\Omega = 0.593\text{ mA}$ . Now, certainly the current has dropped from the ideal level, but the difference in results is only about 1%—nothing major, and the measurement can be used for most purposes. If the series resistors were in the same range as the  $250\ \Omega$  resistors, we would have a different problem, and we would have to look at the results very carefully.

Let us go back to Fig. 5.20 and determine the actual current if each meter on the 2 A scale has an internal resistance of  $1.5\ \Omega$ . The fact that there are four meters will result in an additional resistance of  $(4)(1.5\ \Omega) = 6\ \Omega$  in the circuit, and the current will be  $I_s = E/R_T = 8.4\text{ V}/146\ \Omega \cong 58\text{ mA}$ , rather than the 60 mA under ideal conditions. This value is still close enough to be considered a helpful reading. However, keep in mind that if we were measuring the current in the circuit, we would use only one ammeter, and the current would be  $I_s = E/R_T = 8.4\text{ V}/141.5\ \Omega \cong 59\text{ mA}$ , which can certainly be approximated as 60 mA.

In general, therefore, be aware that this internal resistance must be factored in, but for the reasons just described, most readings can be used as an excellent first approximation to the actual current.



**FIG. 5.73**

*Including the effects of the internal resistance of an ammeter: (a) 2 mA scale; (b) 2 A scale.*

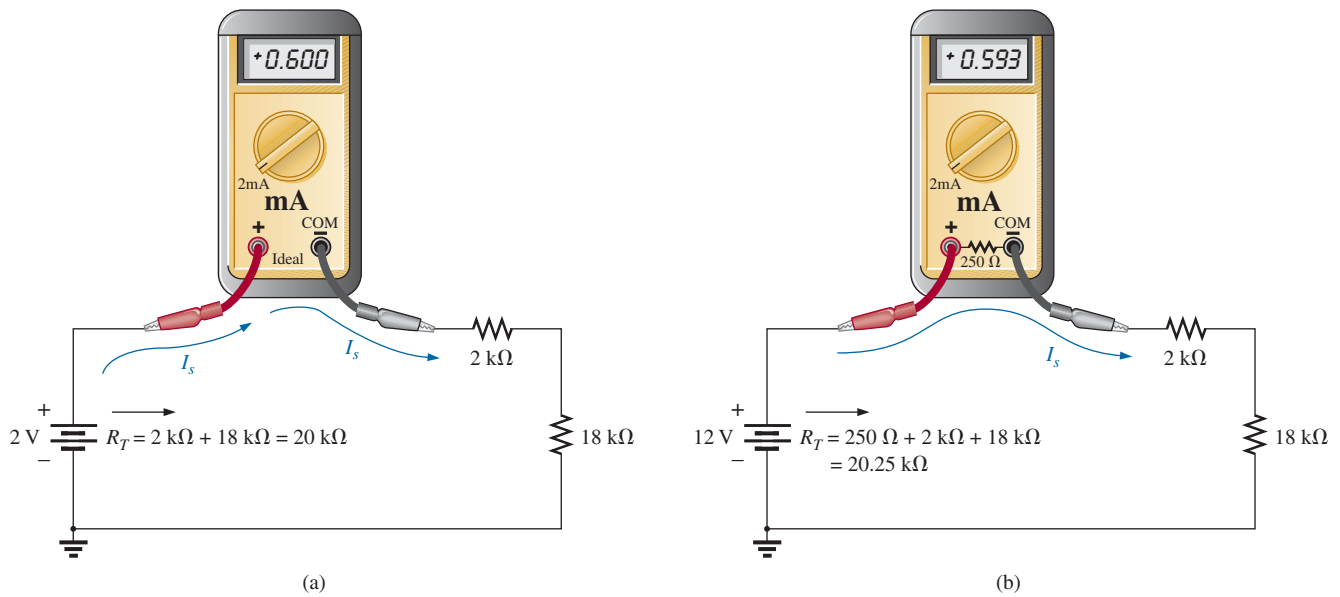


FIG. 5.74

Applying an ammeter, set on the 2 mA scale, to a circuit with resistors in the kilohm range: (a) ideal; (b) practical.

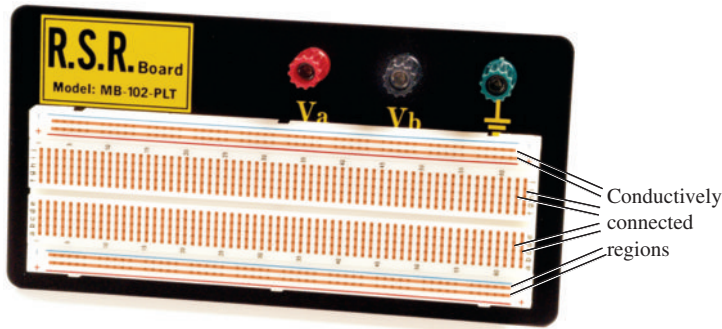
It should be added that because of this *insertion problem* with ammeters, and because of the very important fact that the *circuit must be disturbed* to measure a current, ammeters are not used as much as you might initially expect. Rather than break a circuit to insert a meter, the voltage across a resistor is often measured and the current then calculated using Ohm's law. This eliminates the need to worry about the level of the meter resistance and having to disturb the circuit. Another option is to use the clamp-type ammeters introduced in Chapter 2, removing the concerns about insertion loss and disturbing the circuit. Of course, for many practical applications (such as on power supplies), it is convenient to have an ammeter permanently installed so that the current can quickly be read from the display. In such cases, however, the design is such as to compensate for the insertion loss.

In summary, therefore, keep in mind that the insertion of an ammeter will add resistance to the branch and will affect the current and voltage levels. However, in most cases the effect is minimal, and the reading will provide a good first approximation to the actual level.

The loading effect of voltmeters are discussed in detail in the next chapter because loading is not a series effect. In general, however, the results will be similar in many ways to those of the ammeter, but the major difference is that the circuit does not have to be disturbed to apply the meter.

## 5.12 PROTOBOARDS (BREADBOARDS)

At some point in the design of any electrical/electronic system, a prototype must be built and tested. One of the most effective ways to build a testing model is to use the **protoboard** (in the past most commonly called a **breadboard**) in Fig. 5.75. It permits a direct connection of the power supply and provides a convenient method to hold and connect the components. There isn't a great deal to learn about the protoboard, but it is important to point out some of its characteristics, including the way the elements are typically connected.

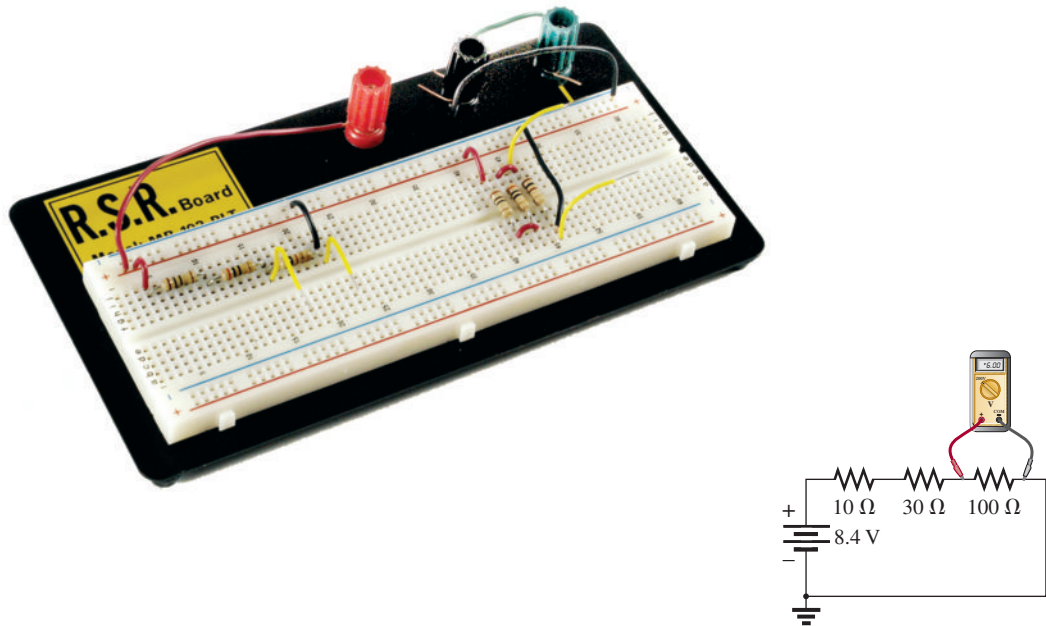


**FIG. 5.75**

*Protoboard with areas of conductivity defined using two different approaches.*

The red terminal  $V_a$  is connected directly to the positive terminal of the dc power supply, with the black lead  $V_b$  connected to the negative terminal and the green terminal used for the ground connection. Under the hole pattern, there are continuous horizontal copper strips under the top and bottom rows, as shown by the copper bands in Fig. 5.75. In the center region, the conductive strips are vertical but do not extend beyond the deep notch running the horizontal length of the board. That's all there is to it, although it will take some practice to make the most effective use of the conductive patterns.

As examples, the network in Fig. 5.12 is connected on the protoboard in the photo in Fig. 5.76 using *two different approaches*. After the dc power supply has been hooked up, a lead is brought down from the positive red terminal to the top conductive strip marked “+.” Keep in mind that now the entire strip is connected to the positive terminal of the supply. The negative terminal is connected to the bottom strip marked with



**FIG. 5.76**

*Two setups for the network in Fig. 5.12 on a protoboard with yellow leads added to each configuration to measure voltage  $V_3$  with a voltmeter.*

a minus sign (–), so that 8.4 V can be read at any point between the top positive strip and the bottom negative strip. A ground connection to the negative terminal of the battery was made at the site of the three terminals. For the user’s convenience, kits are available in which the length of the wires is color coded. Otherwise, a spool of 24 gage wire is cut to length and the ends are stripped. In general, feel free to use the extra length—everything doesn’t have to be at right angles. For most proto-boards, 1/4 W resistors will insert nicely in the board. For clarity, 1/2 W resistors are used in Fig. 5.76. The voltage across any component can be easily read by inserting additional leads as shown in the figure (yellow leads) for the voltage  $V_3$  of each configuration (the yellow wires) and attaching the meter. For any network, the components can be wired in a variety of ways. Note in the configuration on the right that the horizontal break through the center of the board was used to isolate the two terminals of each resistor. Even though there are no set standards, it is important that the arrangement can *easily be understood* by someone else.

Additional setups using the protoboard are in the chapters to follow so that you can become accustomed to the manner in which it is used most effectively. You will probably see the protoboard quite frequently in your laboratory sessions or in an industrial setting.

### 5.13 APPLICATIONS

Before looking at a few applications, we need to consider a few general characteristics of the series configuration that you should always keep in mind when designing a system. First, and probably the most important, is that

*if one element of a series combination of elements should fail, it will disrupt the response of all the series elements. If an open circuit occurs, the current will be zero. If a short circuit results, the voltage will increase across the other elements, and the current will increase in magnitude.*

Second, and just a thought you should always keep in mind, is that

*for the same source voltage, the more elements you place in series, the less the current and the less the voltage across all the elements of the series combination.*

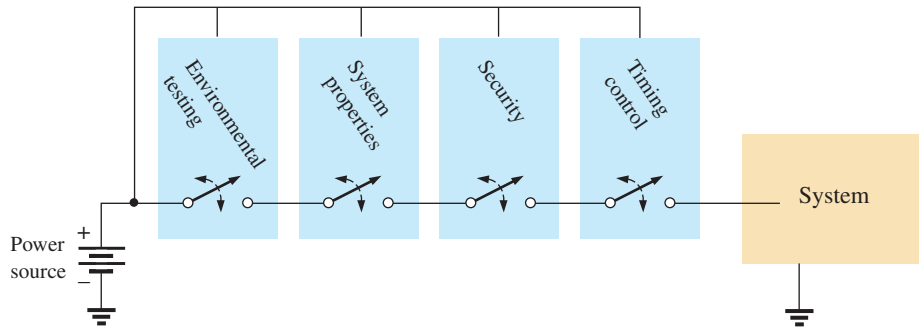
Last, and a result discussed in detail in this chapter, is that

*the current is the same for each element of a series combination, but the voltage across each element is a function of its terminal resistance.*

There are other characteristics of importance that you will learn as you investigate possible areas of application, but the above are the most important.

### Series Control

One common use of the series configuration is in setting up a system that ensures that everything is in place before full power is applied. In Fig. 5.77, various sensing mechanisms can be tied to series switches, preventing power to the load until all the switches are in the closed or on position. For instance, as shown in Fig. 5.77, one component may test the environment for dangers such as gases, high temperatures, and so on. The

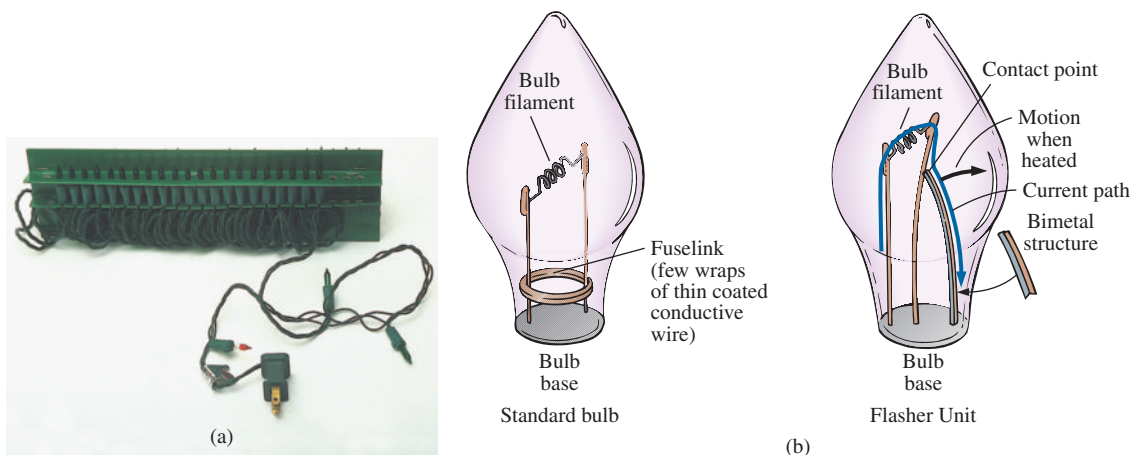


**FIG. 5.77**  
Series control over an operating system.

next component may be sensitive to the properties of the system to be energized to be sure all components are working. Security is another factor in the series sequence, and finally a timing mechanism may be present to ensure limited hours of operation or to restrict operating periods. The list is endless, but the fact remains that “all systems must be go” before power reaches the operating system.

### Holiday Lights

In recent years, the small blinking holiday lights with 50 to 100 bulbs on a string have become very popular [see Fig. 5.78(a)]. Although holiday lights can be connected in series or parallel (to be described in the next chapter), the smaller blinking light sets are normally connected in series. It is relatively easy to determine if the lights are connected in series. If one wire enters and leaves the bulb casing, they are in series. If two wires enter and leave, they are probably in parallel. *Normally, when bulbs are connected in series, if one burns out (the filament breaks and the circuit opens), all the bulbs go out since the current path has been interrupted.* However, the bulbs in Fig. 5.78(a) are specially designed, as shown in Fig. 5.78(b), to permit current to continue to flow to the other bulbs when the filament burns out. At the base of each bulb, there is a fuse link wrapped around the two posts holding the filament. The fuse link of a soft conducting metal appears to be touching the two vertical posts, but in fact



**FIG. 5.78**  
Holiday lights: (a) 50-unit set; (b) bulb construction.



a coating on the posts or fuse link prevents conduction from one to the other under normal operating conditions. If a filament should burn out and create an open circuit between the posts, the current through the bulb and other bulbs would be interrupted if it were not for the fuse link. At the instant a bulb opens up, current through the circuit is zero, and the full 120 V from the outlet appears across the bad bulb. This high voltage from post to post of a single bulb is of sufficient potential difference to establish current through the insulating coatings and spot-weld the fuse link to the two posts. The circuit is again complete, and all the bulbs light except the one with the activated fuse link. Keep in mind, however, that each time a bulb burns out, there is more voltage across the other bulbs of the circuit, making them burn brighter. Eventually, if too many bulbs burn out, the voltage reaches a point where the other bulbs burn out in rapid succession. To prevent this, you must replace burned-out bulbs at the earliest opportunity.

The bulbs in Fig. 5.78(b) are rated 2.5 V at 0.2 A or 200 mA. Since there are 50 bulbs in series, the total voltage across the bulbs will be  $50 \times 2.5 \text{ V}$  or 125 V, which matches the voltage available at the typical home outlet. Since the bulbs are in series, the current through each bulb will be 200 mA. The power rating of each bulb is therefore  $P = VI = (2.5 \text{ V})(0.2 \text{ A}) = 0.5 \text{ W}$  with a total wattage demand of  $50 \times 0.5 \text{ W} = 25 \text{ W}$ .

A schematic representation for the set of Fig. 5.78(a) is provided in Fig. 5.79(a). Note that only one flasher unit is required. Since the bulbs are in

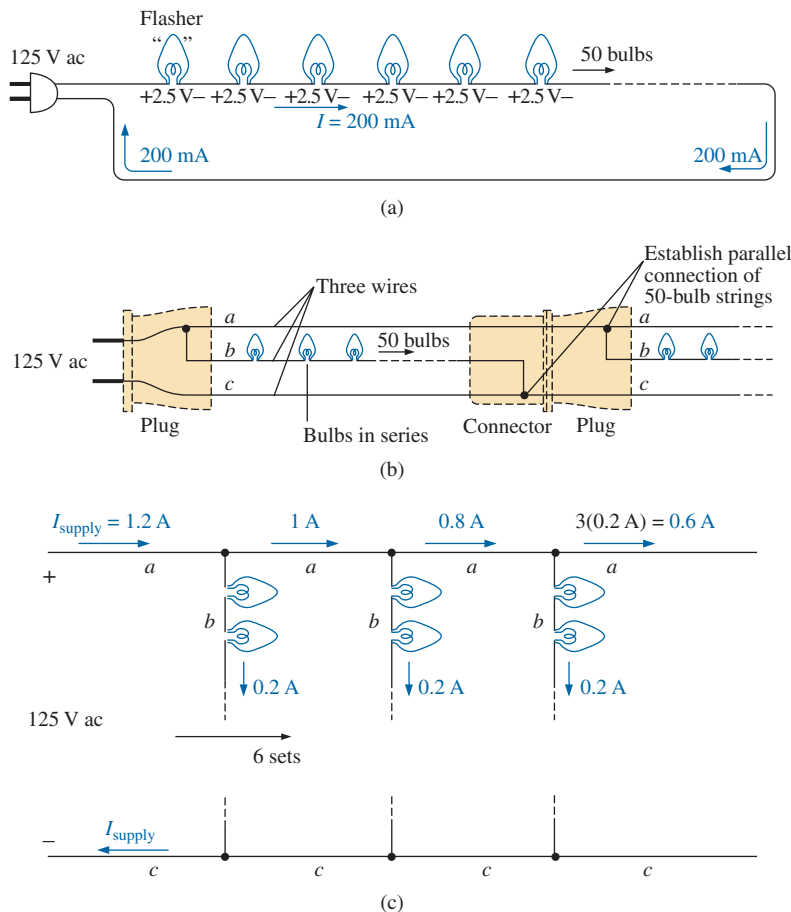


FIG. 5.79

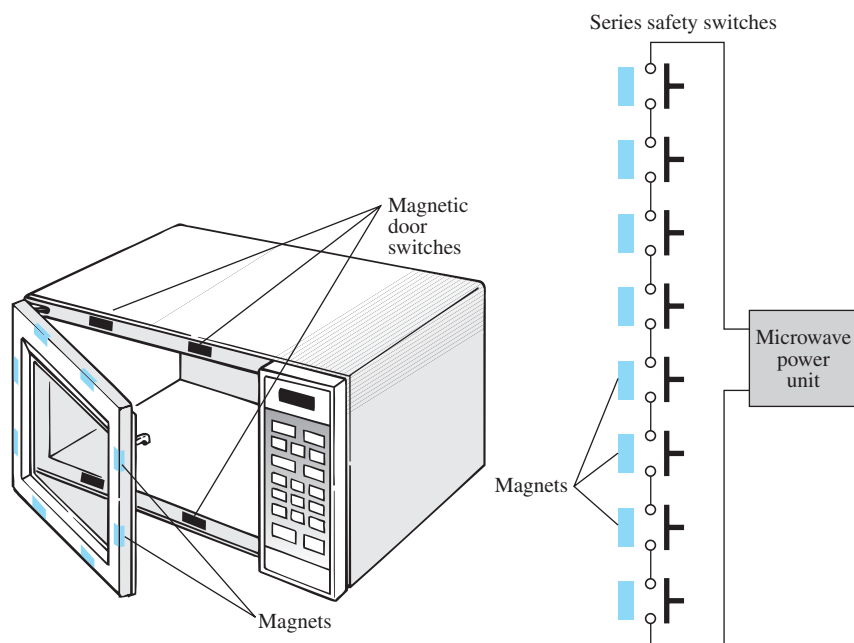
(a) Single-set wiring diagram; (b) special wiring arrangement; (c) redrawn schematic; (d) special plug and flasher unit.

series, when the flasher unit interrupts the current flow, it turns off all the bulbs. As shown in Fig. 5.78(b), the flasher unit incorporates a bimetal thermal switch that opens when heated to a preset level by the current. As soon as it opens, it begins to cool down and closes again so that current can return to the bulbs. It then heats up again, opens up, and repeats the entire process. The result is an on-and-off action that creates the flashing pattern we are so familiar with. Naturally, in a colder climate (for example, outside in the snow and ice), it initially takes longer to heat up, so the flashing pattern is slow at first, but as the bulbs warm up, the frequency increases.

The manufacturer specifies that no more than six sets should be connected together. How can you connect the sets together, end to end, without reducing the voltage across each bulb and making all the lights dimmer? If you look closely at the wiring, you will find that since the bulbs are connected in series, there is one wire to each bulb with additional wires from plug to plug. Why would they need two additional wires if the bulbs are connected in series? Because when each set is connected together, they are actually in a parallel arrangement (to be discussed in the next chapter). This unique wiring arrangement is shown in Fig. 5.79(b) and redrawn in Fig. 5.79(c). Note that the top line is the hot line to all the connected sets, and the bottom line is the return, neutral, or ground line for all the sets. Inside the plug in Fig. 5.79(d), the hot line and return are connected to each set, with the connections to the metal spades of the plug as shown in Fig. 5.79(b). We will find in the next chapter that the current drawn from the wall outlet for parallel loads is the sum of the current to each branch. The result, as shown in Fig. 5.79(c), is that the current drawn from the supply is  $6 \times 200 \text{ mA} = 1.2 \text{ A}$ , and the total wattage for all six sets is the product of the applied voltage and the source current or  $(120 \text{ V})(1.2 \text{ A}) = 144 \text{ W}$  with  $144 \text{ W}/6 = 24 \text{ W}$  per set.

## Microwave Oven

Series circuits can be very effective in the design of safety equipment. Although we all recognize the usefulness of the microwave oven, it can be

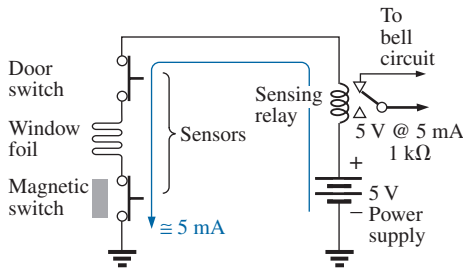


**FIG. 5.80**

*Series safety switches in a microwave oven.*



quite dangerous if the door is not closed or sealed properly. It is not enough to test the closure at only one point around the door because the door may be bent or distorted from continual use, and leakage can result at some point distant from the test point. One common safety arrangement appears in Fig. 5.80. Note that magnetic switches are located all around the door, with the magnet in the door itself and the magnetic door switch in the main frame. Magnetic switches are simply switches where the magnet draws a magnetic conducting bar between two contacts to complete the circuit—somewhat revealed by the symbol for the device in the circuit diagram in Fig. 5.80. Since the magnetic switches are all in series, they must all be closed to complete the circuit and turn on the power unit. If the door is sufficiently out of shape to prevent a single magnet from getting close enough to the switching mechanism, the circuit will not be complete, and the power cannot be turned on. Within the control unit of the power supply, either the series circuit completes a circuit for operation or a sensing current is established and monitored that controls the system operation.



**FIG. 5.81**  
Series alarm circuit.

### Series Alarm Circuit

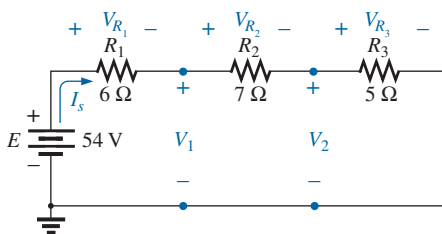
The circuit in Fig. 5.81 is a simple alarm circuit. Note that every element of the design is in a series configuration. The power supply is a 5 V dc supply that can be provided through a design similar to that in Fig. 2.33, a dc battery, or a combination of an ac and a dc supply that ensures that the battery will always be at full charge. If all the sensors are closed, a current of 5 mA results because of the terminal load of the relay of about 1 kΩ. That current energizes the relay and maintains an off position for the alarm. However, if any of the sensors and opened, the current will be interrupted, the relay will let go, and the alarm circuit will be energized. With relatively short wires and a few sensors, the system should work well since the voltage drop across each is minimal. However, since the alarm wire is usually relatively thin, resulting in a measurable resistance level, if the wire to the sensors is too long, a sufficient voltage drop could occur across the line, reducing the voltage across the relay to a point where the alarm fails to operate properly. Thus, wire length is a factor that must be considered if a series configuration is used. Proper sensitivity to the length of the line should remove any concerns about its operation. An improved design is described in Chapter 8.

## 5.14 COMPUTER ANALYSIS

### PSpice

In Section 4.9, the basic procedure for setting up the PSpice folder and running the program were presented. Because of the detail provided in that section, you should review it before proceeding with this example. Because this is only the second example using PSpice, some detail is provided, but not at the level of Section 4.9.

The circuit to be investigated appears in Fig. 5.82. You will use the **PSpice** folder established in Section 4.9. Double-clicking on the **OrCAD 10.0 DEMO/CAPTURE CIS** icon opens the window. A new project is initiated by selecting the **Create document** key at the top left of the screen (it looks like a page with a star in the upper left corner). The result is the **New Project** dialog box in which **PSpice 5-1** is entered as the **Name**. The



**FIG. 5.82**  
Series dc network to be analyzed using PSpice.

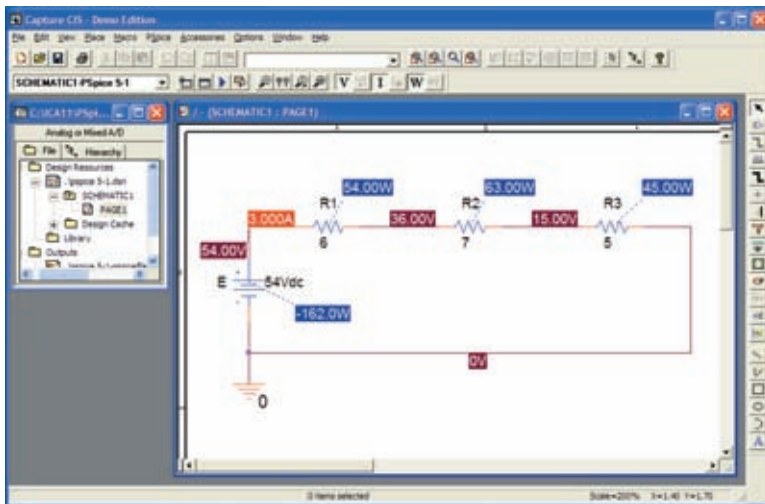


FIG. 5.83

*Applying PSpice to a series dc circuit.*

**Analog or Mixed A/D** is already selected, and **PSpice** appears as the **Location**. Click **OK**, and the **Create PSpice Project** dialog box appears. Select **Create a blank project**, click **OK**, and the working windows appear. Grab the left edge of the **SCHEMATIC1:PAGE1** window to move it to the right so that you can see both screens. Clicking the + sign in the **Project Manager** window allows you to set the sequence down to **PAGE1**. You can change the name of the **SCHEMATIC1** by selecting it and right-clicking. Choose **Rename** from the list. Enter **PSpice 5-1** in the **Rename Schematic** dialog box. In Fig. 5.83 it was left as **SCHEMATIC1**.

This next step is important. If the toolbar on the right does not appear, left-click anywhere on the **SCHEMATIC1:PAGE1** screen. To start building the circuit, select **Place a part** key (the second one down) to open the **Place Part** dialog box. Note that the **SOURCE** library is already in place in the **Library** list (from the efforts of Chapter 4). Selecting **SOURCE** results in the list of sources under **Part List**, and **VDC** can be selected. Click **OK**, and the cursor can put it in place with a single left click. Right-click and select **End Mode** to end the process since the network has only one source. One more left click, and the source is in place. Select the **Place a Part** key again, followed by **ANALOG** library to find the resistor **R**. Once the resistor has been selected, click **OK** to place it next to the cursor on the screen. This time, since three resistors need to be placed, there is no need to go to **End Mode** between depositing each. Simply click one in place, then the next, and finally the third. Then right-click to end the process with **End Mode**. Finally, add a **GND** by selecting the appropriate key from the right toolbar and selecting **0/SOURCE** in the **Place Ground** dialog box. Click **OK**, and place the ground as shown in Fig. 5.83.

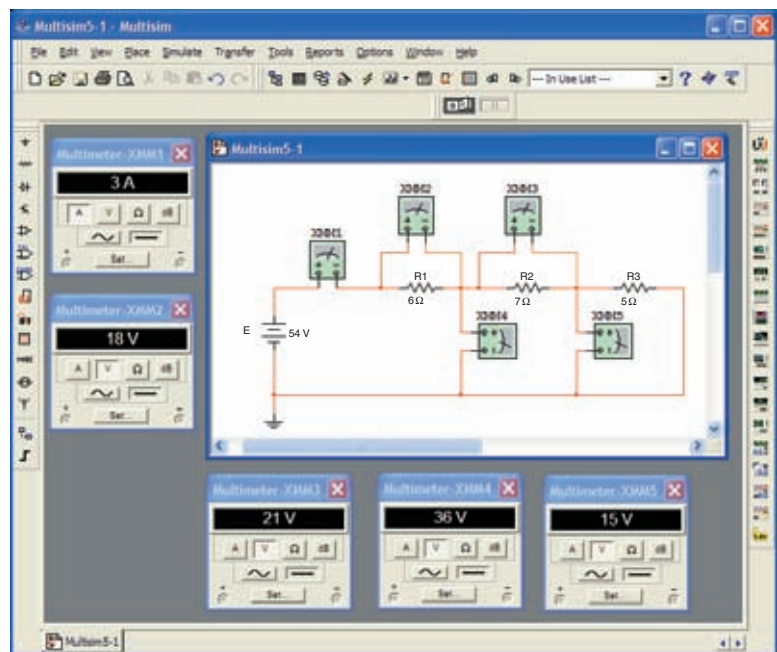
Connect the elements by using the **Place a wire** key to obtain the crosshair on the screen. Start at the top of the voltage source with a left click, and draw the wire, left-clicking it at every 90° turn. When a wire is connected from one element to another, move on to the next connection to be made—there is no need to go **End Mode** between connections. Now set the labels and values by double-clicking on each parameter to obtain a **Display Properties** dialog box. Since the dialog box appears with the

quantity of interest in a blue background, type in the desired label or value, followed by **OK**. The network is now complete and ready to be analyzed.

Before simulation, select the **V**, **I**, and **W** in the toolbar at the top of the window to ensure that the voltages, currents, and power are displayed on the screen. To simulate, select the **New Simulation Profile** key (which appears as a data sheet on the second toolbar down with a star in the top left corner) to obtain the **New Simulation** dialog box. Enter **Bias Point** for a dc solution under **Name**, and hit the **Create** key. A **Simulation Settings-Bias Point** dialog box appears in which **Analysis** is selected and **Bias Point** is found under the **Analysis type** heading. Click **OK**, and then select the **Run PSpice** key (the blue arrow) to initiate the simulation. Exit the resulting screen. The resulting display (Fig. 5.83) shows the current is 3 A for the circuit with 15 V across  $R_3$ , and 36 V from a point between  $R_1$  and  $R_2$  to ground. The voltage across  $R_2$  is  $36\text{ V} - 15\text{ V} = 21\text{ V}$ , and the voltage across  $R_1$  is  $54\text{ V} - 36\text{ V} = 18\text{ V}$ . The power supplied or dissipated by each element is also listed.

## Multisim

The construction of the network in Fig 5.84 using Multisim is simply an extension of the procedure outlined in Chapter 4. For each resistive element or meter, the process is repeated. The label for each increases by one as additional resistors or meters are added. Remember from the discussion of Chapter 4 that you should add the meters before connecting the elements together because the meters take space and must be properly oriented. The current is determined by the **XMM1** ammeter and the voltages by **XMM2** through **XMM5**. Of particular importance, note that



**FIG. 5.84**

*Applying Multisim to a series dc circuit.*

*in Multisim the meters are connected in exactly the same way they would be placed in an active circuit in the laboratory. Ammeters are in series with the branch in which the current is to be determined, and voltmeters are connected between the two points of interest (across resistors). In addition, for positive readings, ammeters are connected so that conventional current enters the positive terminal, and voltmeters are connected so that the point of higher potential is connected to the positive terminal.*

The meter settings are made by double-clicking on the meter symbol on the schematic. In each case, **V** or **I** had to be chosen, but the horizontal line for dc analysis is the same for each. Again, you can select the **Set** key to see what it controls, but the default values of meter input resistance levels are fine for all the analyses described in this text. Leave the meters on the screen so that the various voltages and the current level will be displayed after the simulation.

Recall from Chapter 4 that elements can be moved by simply clicking on each schematic symbol and dragging it to the desired location. The same is true for labels and values. Labels and values are set by double-clicking on the label or value and entering your preference. Click **OK**, and they are changed on the schematic. You do not have to first select a special key to connect the elements. Simply bring the cursor to the starting point to generate the small circle and crosshair. Click on the starting point, and follow the desired path to the next connection path. When in the correct location, click again, and the line appears. All connecting lines can make 90° turns. However, you cannot follow a diagonal path from one point to another. To remove any element, label, or line, click on the quantity to obtain the four-square active status, and select the **Delete** key or the scissors key on the top menu bar.

Recall from Chapter 4 that you can initiate simulation through the sequence **Simulate-Run** selecting the **Lightning Key**, or switching the **Simulate Switch** to the **1** position. You can stop the simulation by selecting the same **Lightning** key or switching the **Simulate Switch** to the **0** position.

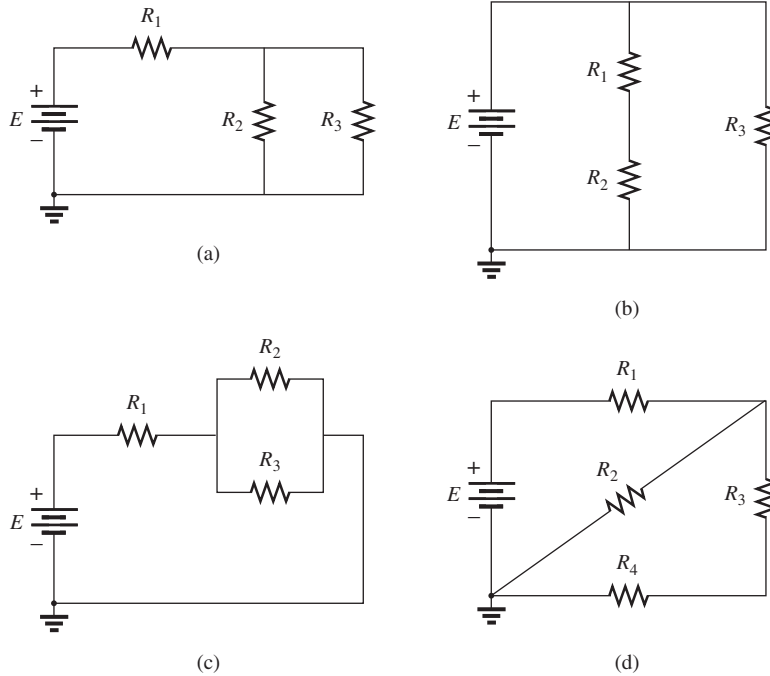
Note from the results that the sum of the voltages measured by XMM2 and XMM4 equals the applied voltage. All the meters are considered ideal so there is no voltage drop across the XMM1 ammeter. In addition, they do not affect the value of the current measured by XMM1. All the voltmeters have essentially infinite internal resistance while the ammeters all have zero internal resistance. Of course, the meters can be entered as anything but ideal using the **Set** option. Note also that the sum of the voltages measured by XMM3 and XMM5 equals that measured by XMM4 as required by Kirchhoff's voltage law.

**PROBLEMS**

**SECTION 5.2 Series Resistors**

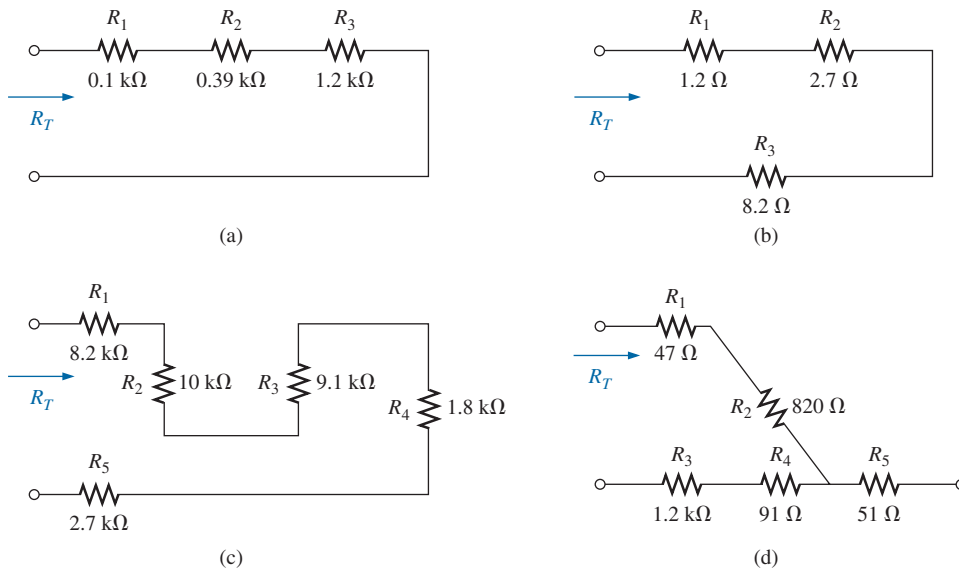
- For each configuration in Fig. 5.85, find the individual (not combinations of) elements (voltage sources and/or resistors) that are in series. If necessary, use the fact that elements in

series have the same current. Simply list those that satisfy the conditions for a series relationship. We will learn more about other combinations later.



**FIG. 5.85**  
Problem 1.

- Find the total resistance  $R_T$  for each configuration in Fig. 5.86. Note that only standard resistor values were used.



**FIG. 5.86**  
Problem 2.

3. For each circuit board in Fig. 5.87, find the total resistance between connection tabs 1 and 2.

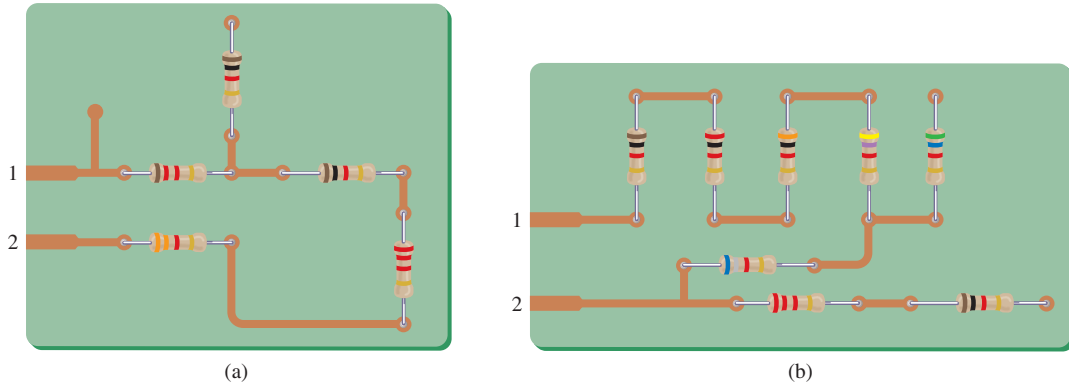


FIG. 5.87  
Problem 3.

4. For the circuit in Fig. 5.88, composed of standard values:
- Which resistor will have the most impact on the total resistance?
  - On an approximate basis, which resistors can be ignored when determining the total resistance?
  - Find the total resistance, and comment on your results for parts (a) and (b).
5. For each configuration in Fig. 5.89, find the unknown resistors using the ohmmeter reading.

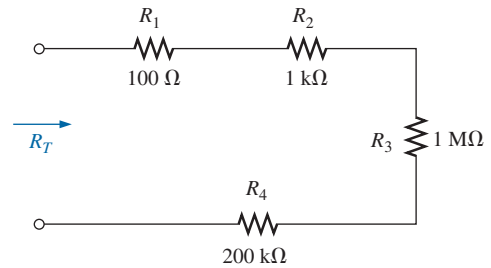


FIG. 5.88  
Problem 4.

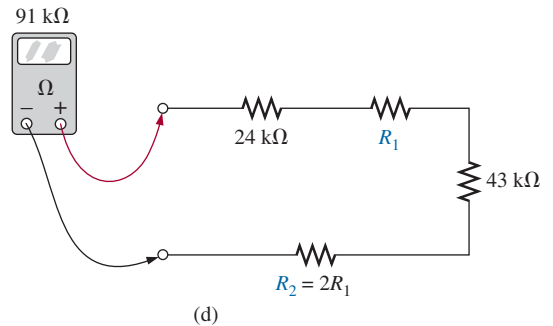
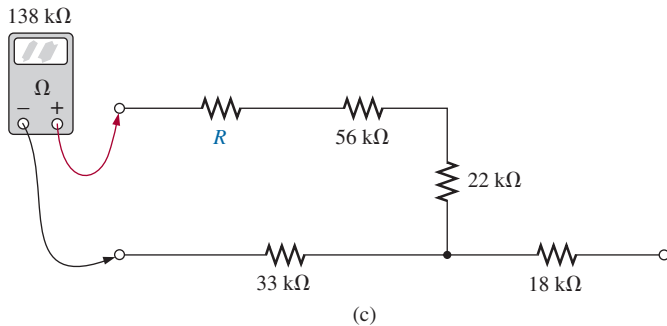
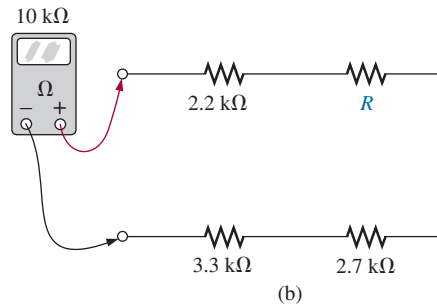
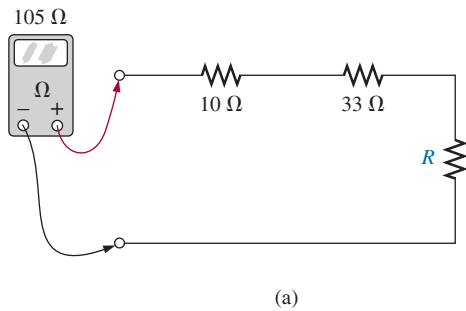


FIG. 5.89  
Problem 5.

6. What is the ohmmeter reading for each configuration in Fig. 5.90?

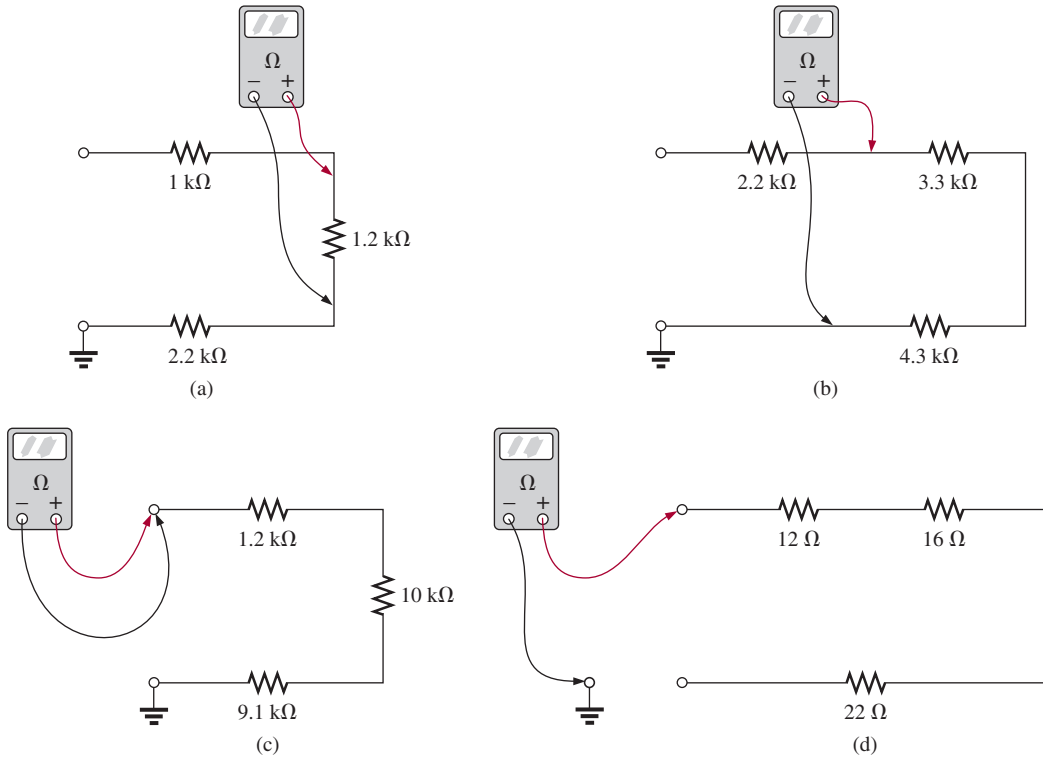


FIG. 5.90  
Problem 6.

SECTION 5.3 Series Circuits

7. For the series configuration in Fig. 5.91, constructed of standard values:
  - a. Find the total resistance.
  - b. Calculate the current.
  - c. Find the voltage across each resistive element.
8. For the series configuration in Fig. 5.92, constructed using standard value resistors:
  - a. Without making a single calculation, which resistive element will have the most voltage across it? Which will have the least?
  - b. Which resistor will have the most impact on the total resistance and the resulting current? Find the total resistance and the current.

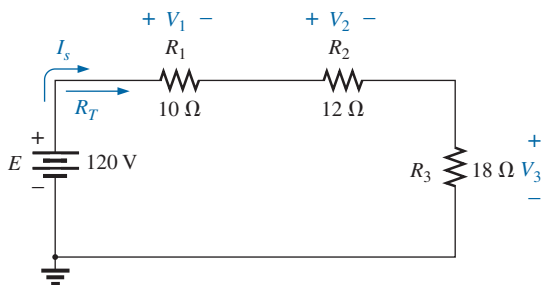


FIG. 5.91  
Problem 7.

- c. Find the voltage across each element and review your response to part (a).
9. Find the applied voltage necessary to develop the current specified in each circuit in Fig. 5.93.
10. For each network in Fig. 5.94, constructed of standard values, determine:
  - a. The current  $I$ .
  - b. The source voltage  $E$ .
  - c. The unknown resistance.
  - d. The voltage across each element.
11. For each configuration in Fig. 5.95, what are the readings of the ammeter and the voltmeter?

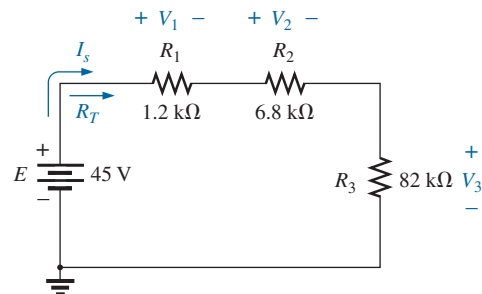
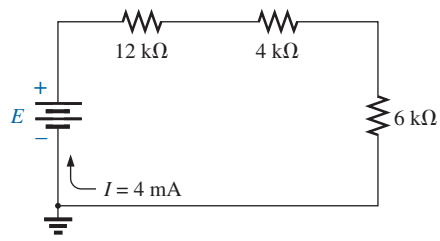
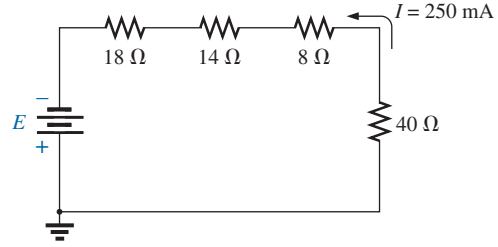


FIG. 5.92  
Problem 8.



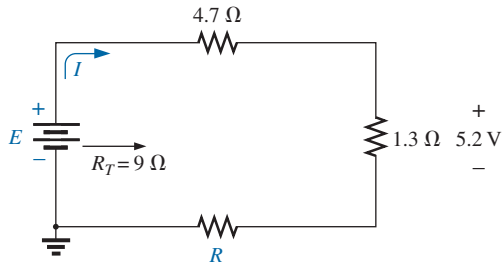
(a)



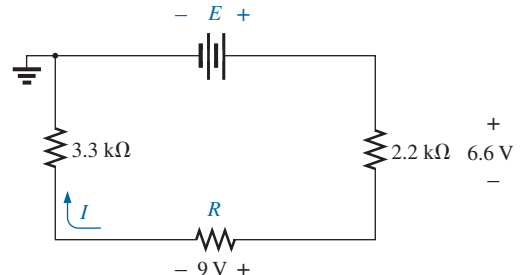
(b)

**FIG. 5.93**

Problem 9.



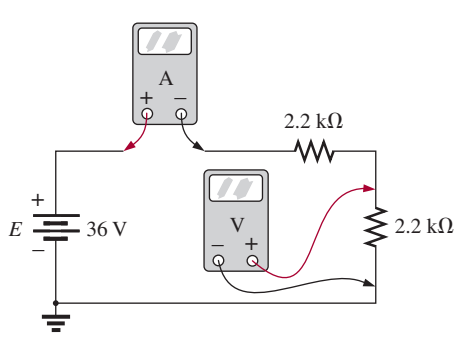
(a)



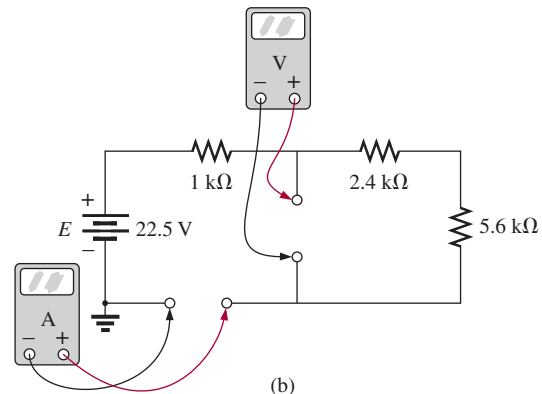
(b)

**FIG. 5.94**

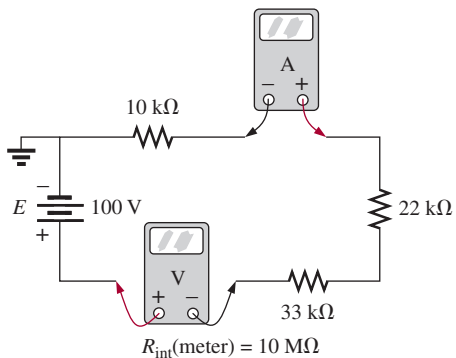
Problem 10.



(a)



(b)



(c)

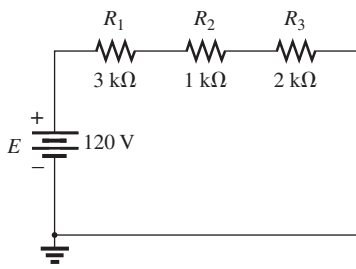
**FIG. 5.95**

Problem 11.



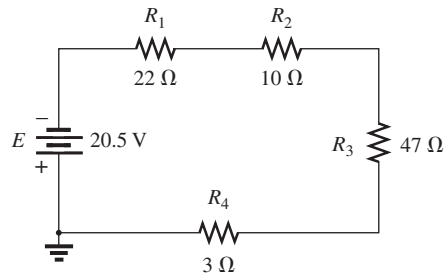
**SECTION 5.4 Power Distribution in a Series Circuit**

12. For the circuit in Fig. 5.96, constructed of standard value resistors:
- Find the total resistance, current, and voltage across each element.
  - Find the power delivered to each resistor.
  - Calculate the total power delivered to all the resistors.
  - Find the power delivered by the source.
  - How does the power delivered by the source compare to that delivered to all the resistors?
  - Which resistor received the most power? Why?
  - What happened to all the power delivered to the resistors?
  - If the resistors are available with wattage ratings of 1/2 W, 1 W, 2 W, and 5 W, what minimum wattage rating can be used for each resistor?

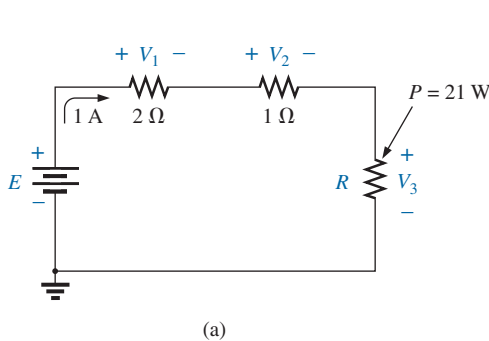


**FIG. 5.96**  
Problem 12.

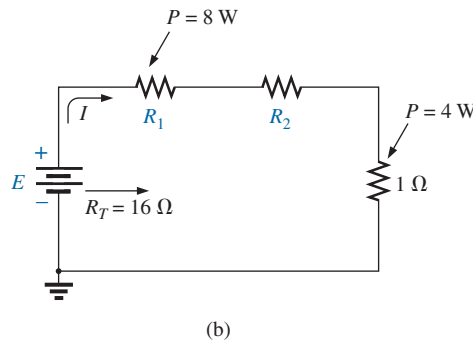
- Repeat Problem 12 for the circuit in Fig. 5.97.
- Find the unknown quantities for the circuits in Fig. 5.98 using the information provided.
- Eight holiday lights are connected in series as shown in Fig. 5.99.
  - If the set is connected to a 120 V source, what is the current through the bulbs if each bulb has an internal resistance of  $28\frac{1}{2}\ \Omega$ ?
  - Determine the power delivered to each bulb.
  - Calculate the voltage drop across each bulb.
  - If one bulb burns out (that is, the filament opens), what is the effect on the remaining bulbs? Why?
- For the conditions specified in Fig. 5.100, determine the unknown resistance.



**FIG. 5.97**  
Problem 13.

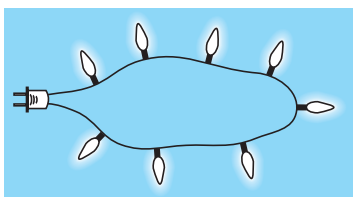


(a)

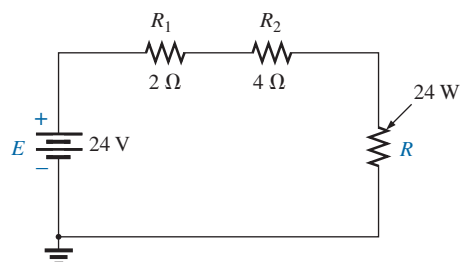


(b)

**FIG. 5.98**  
Problem 14.



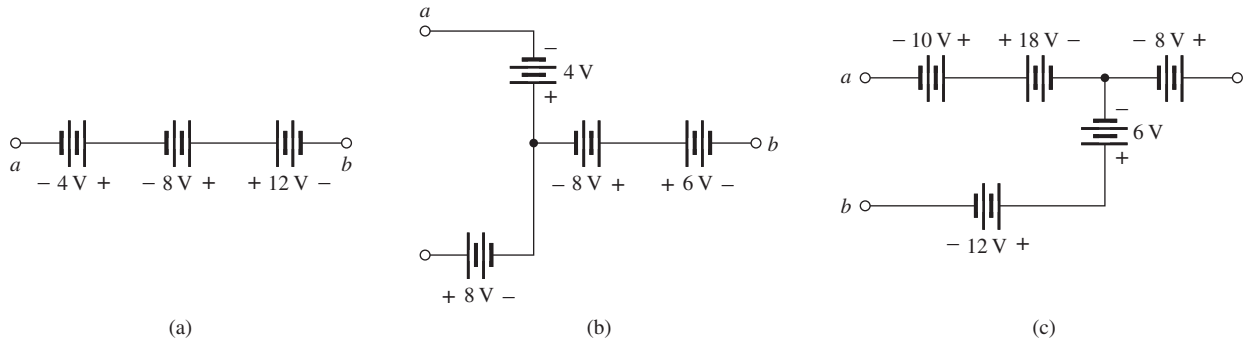
**FIG. 5.99**  
Problem 15.



**FIG. 5.100**  
Problem 16.

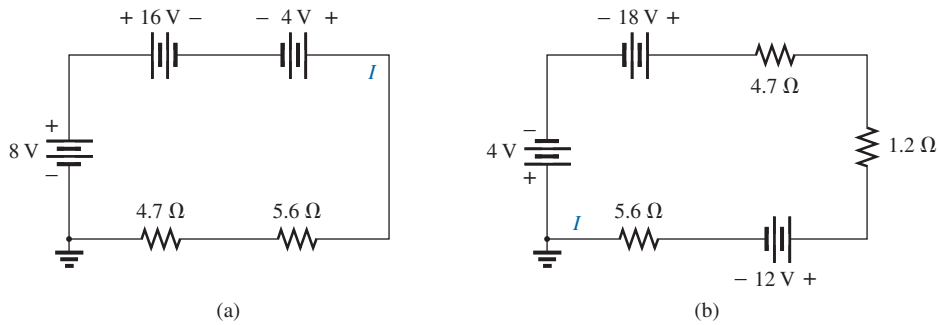
**SECTION 5.5 Voltage Sources in Series**

17. Combine the series voltage sources in Fig. 5.101 into a single voltage source between points *a* and *b*.

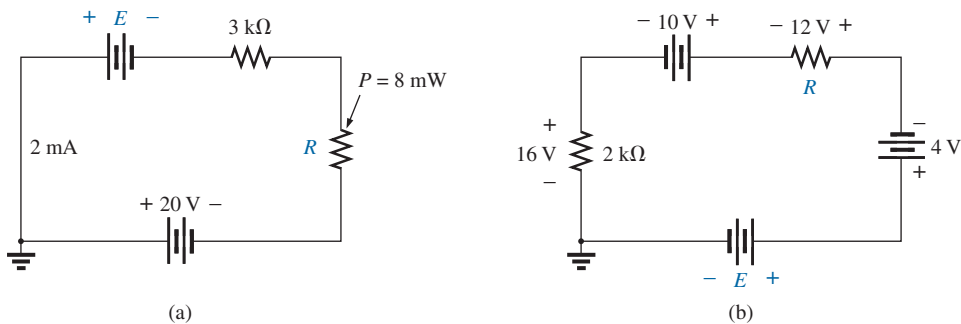


**FIG. 5.101**  
Problem 17.

18. Determine the current *I* and its direction for each network in Fig. 5.102. Before solving for *I*, redraw each network with a single voltage source.
19. Find the unknown voltage source and resistor for the networks in Fig. 5.103. First combine the series voltage sources into a single source. Indicate the direction of the resulting current.



**FIG. 5.102**  
Problem 18.

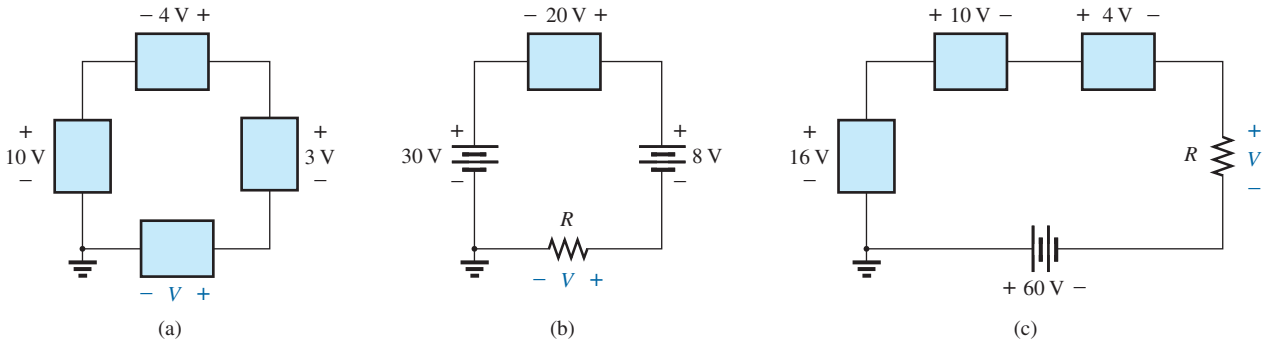


**FIG. 5.103**  
Problem 19.

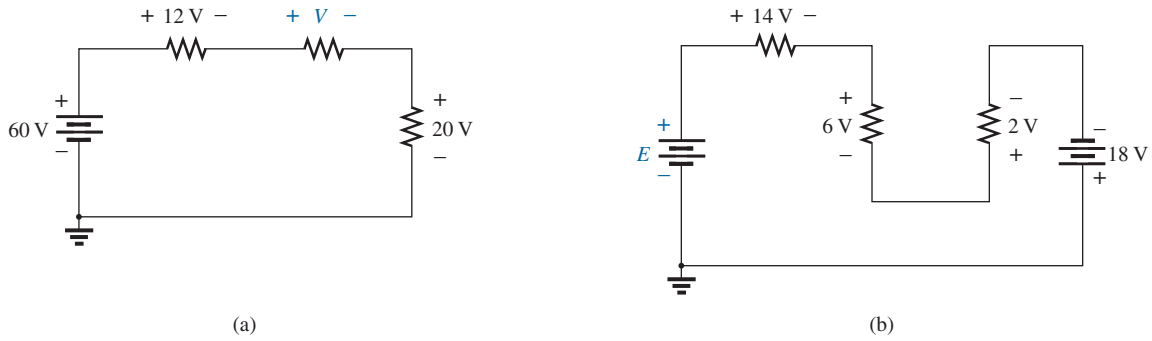
**SECTION 5.6 Kirchhoff's Voltage Law**

- 20. Using Kirchhoff's voltage law, find the unknown voltages for the circuits in Fig. 5.104.
- 21. Using Kirchhoff's voltage law, determine the unknown voltages for the configurations in Fig. 5.105.

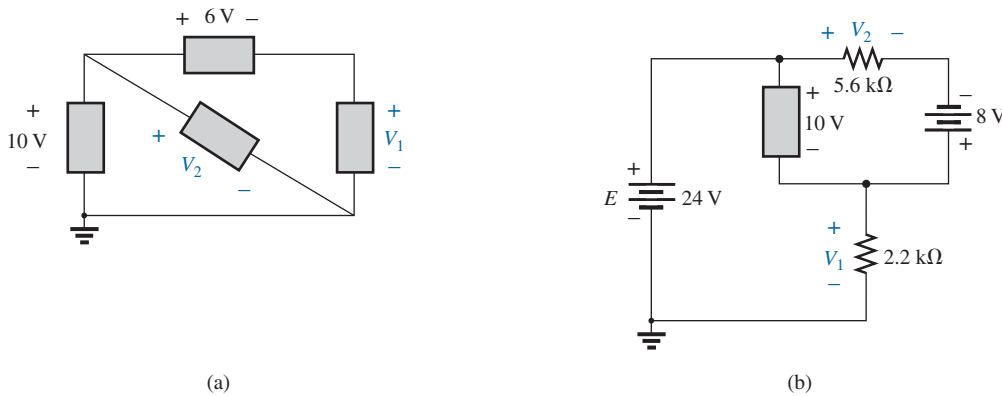
- 22. Using Kirchhoff's voltage law, determine the unknown voltages for the series circuits in Fig. 5.106.
- 23. Using Kirchhoff's voltage law, find the unknown voltages for the configurations in Fig. 5.107.



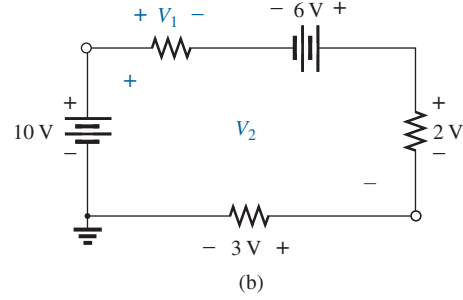
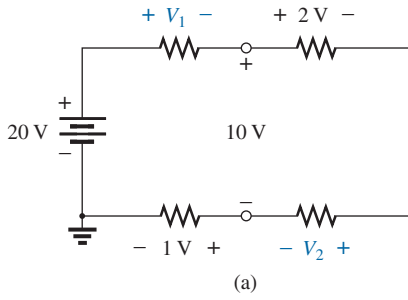
**FIG. 5.104**  
Problem 20.



**FIG. 5.105**  
Problem 21.



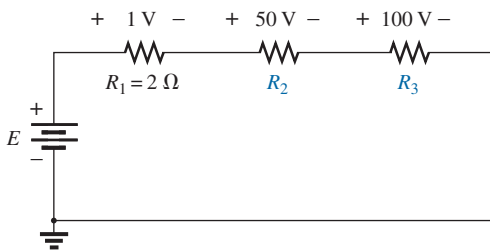
**FIG. 5.106**  
Problem 22.



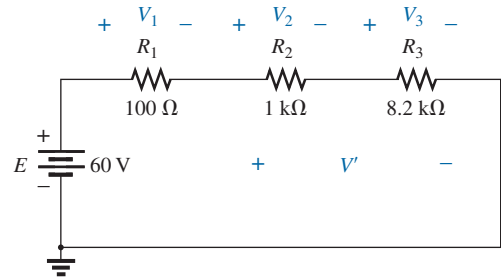
**FIG. 5.107**  
Problem 23.

**SECTION 5.7 Voltage Division in a Series Circuit**

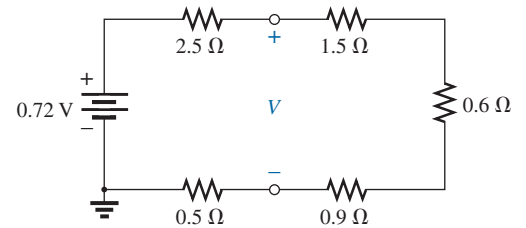
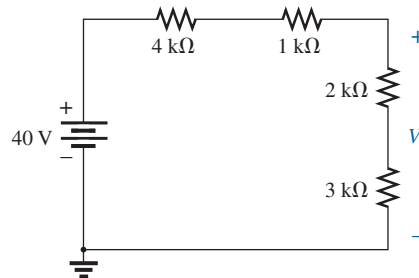
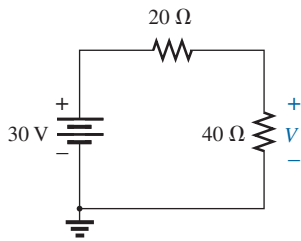
- 24. Determine the values of the unknown resistors in Fig. 5.108 using the provided voltage levels.
- 25. For the configuration in Fig. 5.109, with standard resistor values:
  - a. By inspection, which resistor will receive the largest share of the applied voltage? Why?
  - b. How much larger will voltage  $V_3$  be compared to  $V_2$  and  $V_1$ ?
  - c. Find the voltage across the largest resistor using the voltage divider rule.
  - d. Find the voltage across the series combination of resistors  $R_2$  and  $R_3$ .
- 26. Using the voltage divider rule, find the indicated voltages in Fig. 5.110.



**FIG. 5.108**  
Problem 24.



**FIG. 5.109**  
Problem 25.

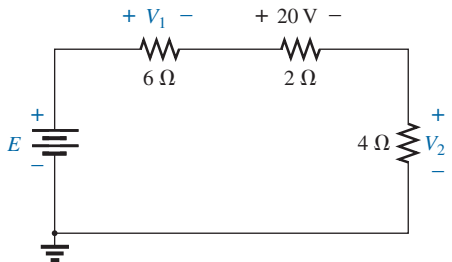


(a)

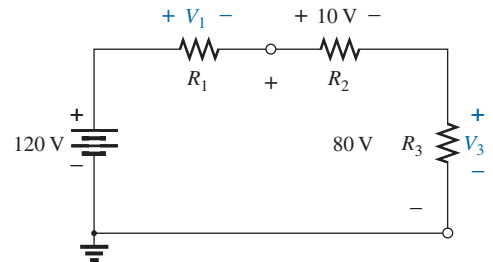
(b)

(c)

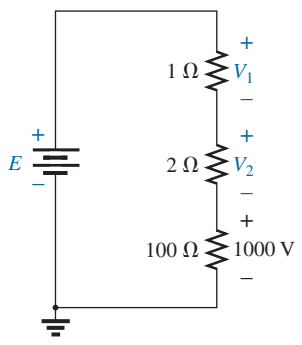
**FIG. 5.110**  
Problem 26.



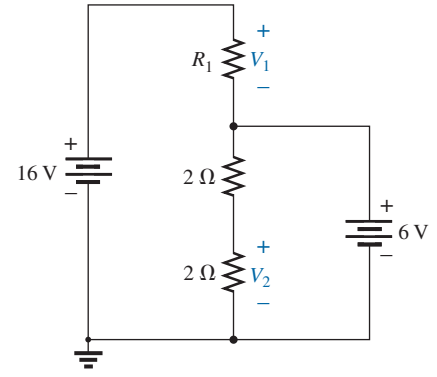
(a)



(b)

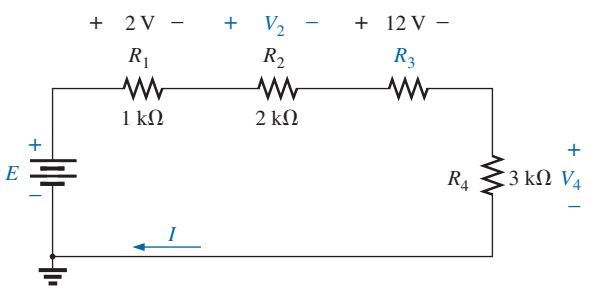


(c)

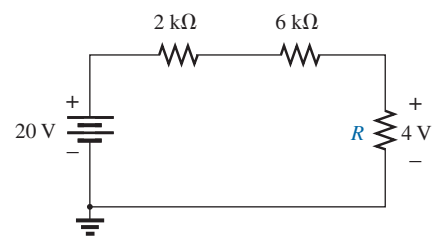


(d)

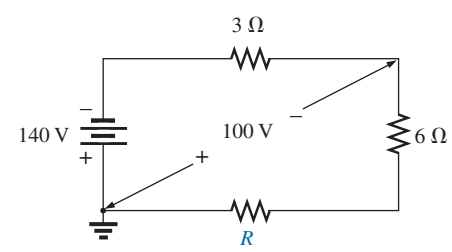
**FIG. 5.111**  
Problem 27.



**FIG. 5.112**  
Problem 28.



(a)

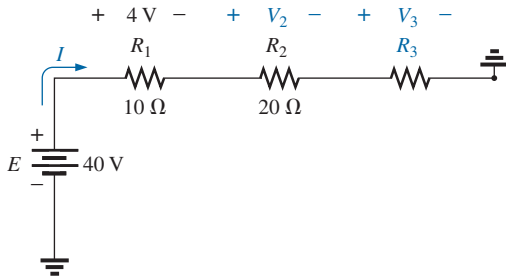


(b)

**FIG. 5.113**  
Problem 29.

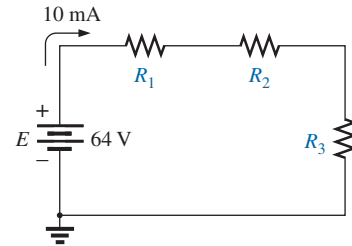
- 27. Using the voltage divider rule or Kirchhoff's voltage law, determine the unknown voltages for the configurations in Fig. 5.111.
- 28. Using the information provided, find the unknown quantities of Fig. 5.112.
- \*29. Using the voltage divider rule, find the unknown resistance for the configurations in Fig. 5.113.

30. Referring to Fig. 5.114.
- Determine  $V_2$ .
  - Calculate  $V_3$ .
  - Determine  $R_3$ .



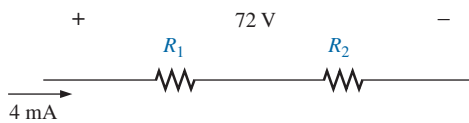
**FIG. 5.114**  
Problem 30.

- \*34. a. Design the circuit in Fig. 5.117 such that  $V_{R_2} = 3V_{R_1}$  and  $V_{R_3} = 4V_{R_2}$ .
- b. If the current is reduced to  $10\ \mu\text{A}$ , what are the new values of  $R_1$ ,  $R_2$ , and  $R_3$ ? How do they compare to the results of part (a)?



**FIG. 5.117**  
Problem 34.

- Design a voltage divider circuit that will permit the use of an 8 V, 50 mA bulb in an automobile with a 12 V electrical system.
  - What is the minimum wattage rating of the chosen resistor if 1/4 W, 1/2 W, and 1 W resistors are available?
32. Design the voltage divider in Fig. 5.115 such that  $V_{R_1} = 1/5V_{R_2}$ . That is, find  $R_1$  and  $R_2$ .

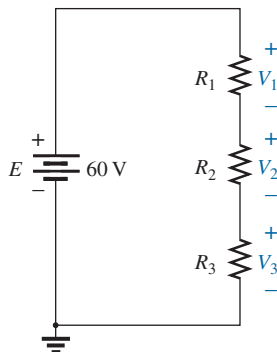


**FIG. 5.115**  
Problem 32.

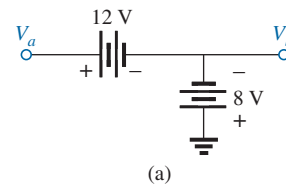
**SECTION 5.9 Notation**

35. Determine the voltages  $V_a$ ,  $V_b$ , and  $V_{ab}$  for the networks in Fig. 5.118.

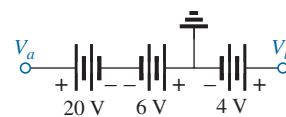
33. Find the voltage across each resistor in Fig. 5.116 if  $R_1 = 2R_3$  and  $R_2 = 7R_3$ .



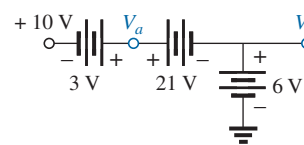
**FIG. 5.116**  
Problem 33.



(a)



(b)



(c)

**FIG. 5.118**  
Problem 35.

36. Determine the current  $I$  (with direction) and the voltage  $V$  (with polarity) for the networks in Fig. 5.119.
37. Determine the voltages  $V_a$  and  $V_1$  for the networks in Fig. 5.120.
38. For the network in Fig. 5.121 determine the voltages:
- $V_a, V_b, V_c, V_d, V_e$
  - $V_{ab}, V_{dc}, V_{cb}$
  - $V_{ac}, V_{db}$

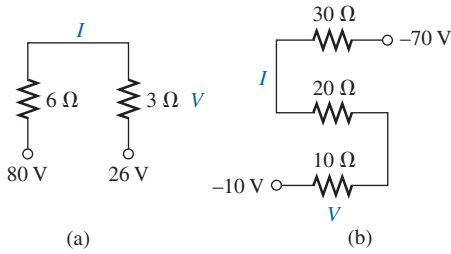


FIG. 5.119  
Problem 36.

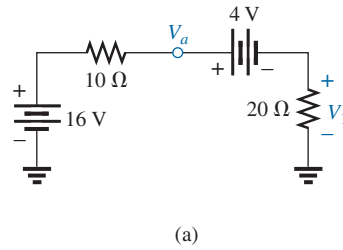


FIG. 5.120  
Problem 37.

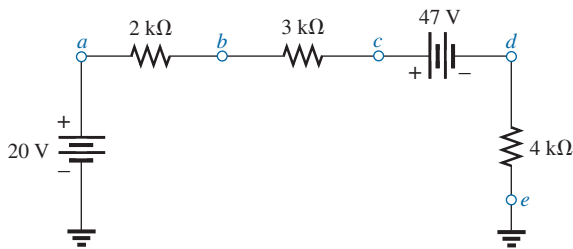


FIG. 5.121  
Problem 38.

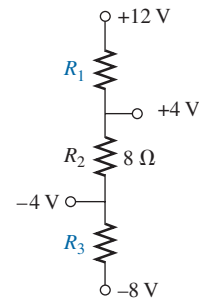


FIG. 5.122  
Problem 39.

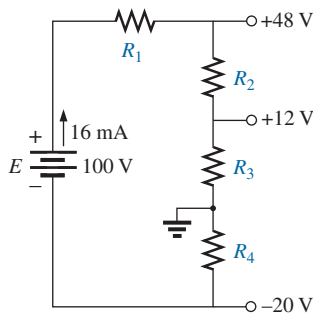


FIG. 5.123  
Problem 40.

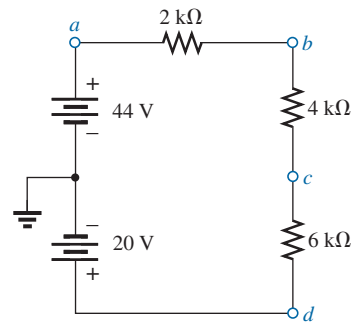


FIG. 5.124  
Problem 41.

39. Given the information appearing in Fig. 5.122, find the level of resistance for  $R_1$  and  $R_3$ .
40. Determine the values of  $R_1, R_2, R_3,$  and  $R_4$  for the voltage divider of Fig. 5.123 if the source current is 16 mA.
41. For the network in Fig. 5.124, determine the voltages:
- $V_a, V_b, V_c, V_d$
  - $V_{ab}, V_{cb}, V_{cd}$
  - $V_{ad}, V_{ca}$

- \*42. For the integrated circuit in Fig. 5.125, determine  $V_0$ ,  $V_4$ ,  $V_7$ ,  $V_{10}$ ,  $V_{23}$ ,  $V_{30}$ ,  $V_{67}$ ,  $V_{56}$ , and  $I$  (magnitude and direction.)
- \*43. For the integrated circuit in Fig. 5.126, determine  $V_0$ ,  $V_{03}$ ,  $V_2$ ,  $V_{23}$ ,  $V_{12}$ , and  $I_i$ .

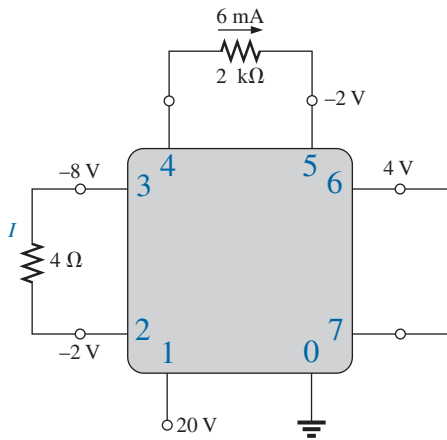


FIG. 5.125  
Problem 42.

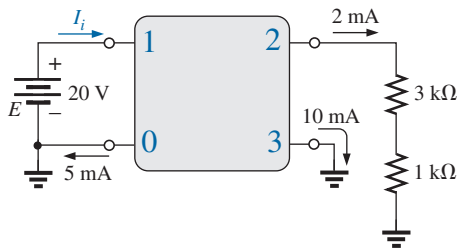


FIG. 5.126  
Problem 43.

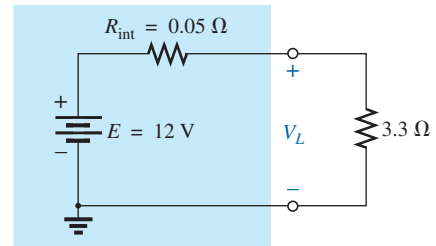


FIG. 5.127  
Problem 45.

**SECTION 5.11 Loading Effects of Instruments**

46. a. Determine the current through the circuit in Fig. 5.128.  
 b. If an ammeter with an internal resistance of  $250\ \Omega$  is inserted into the circuit in Fig. 5.128, what effect will it have on the current level?  
 c. Is the difference in current level a major concern for most applications?

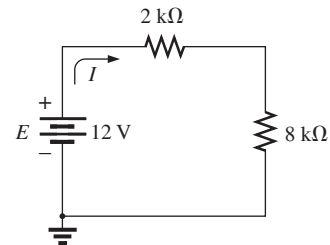


FIG. 5.128  
Problem 46.

**SECTION 5.10 Voltage Regulation and the Internal Resistance of Voltage Sources**

44. a. Find the internal resistance of a battery that has a no-load output of 60 V and that supplies a full-load current of 2 A to a load of  $28\ \Omega$ .  
 b. Find the voltage regulation of the supply.
45. a. Find the voltage to the load (full-load conditions) for the supply in Fig. 5.127.  
 b. Find the voltage regulation of the supply.  
 c. How much power is supplied by the source and lost to the internal resistance under full-load conditions?

**SECTION 5.14 Computer Analysis**

47. Use the computer to verify the results of Example 5.4.  
 48. Use the computer to verify the results of Example 5.5.  
 49. Use the computer to verify the results of Example 5.15.



## GLOSSARY

**Circuit** A combination of a number of elements joined at terminal points providing at least one closed path through which charge can flow.

**Closed loop** Any continuous connection of branches that allows tracing of a path that leaves a point in one direction and returns to that same point from another direction without leaving the circuit.

**Internal resistance** The inherent resistance found internal to any source of energy.

**Kirchhoff's voltage law (KVL)** The algebraic sum of the potential rises and drops around a closed loop (or path) is zero.

**Protoboard (breadboard)** A flat board with a set pattern of conductively connected holes designed to accept 24-gage wire and components with leads of about the same diameter.

**Series circuit** A circuit configuration in which the elements have only one point in common and each terminal is not connected to a third, current-carrying element.

**Two-terminal device** Any element or component with two external terminals for connection to a network configuration.

**Voltage divider rule (VDR)** A method by which a voltage in a series circuit can be determined without first calculating the current in the circuit.

**Voltage regulation (VR)** A value, given as a percent, that provides an indication of the change in terminal voltage of a supply with a change in load demand.