

# *The Fuelless* ENGINE

**Free Energy Technology is now in your hands!** If you decide to build this motor / engine, build it for your own use only and keep it from family, friends and the News Media. The Fuelless Engine is a spin off of the Ed Grey Motor as well as a combination of our own designs as well as The Newman design. This motor is like no other electric motor in the world. You can run this motor on 300 to 1,000 volts dc, (using a special coil design as well as the designs included in these plans.)

Please Keep all of this information to yourself! When Free Energy Electric Motors are allowed to be manufactured here in the USA we will show you how to get even more free energy from your motor than ever thought possible! But for security and Patent reasons we can not reveal to you all our secretes But we will keep your on file and let you know of any updates we can safely share.

You can make the outer shell case out of just about anything you want to. But we suggest you use steel tubing or aluminum tubing for anything over 100 hp. Anything below that you can use 1/2" plywood box. What most of our customers use is green 1/4" x 14" diameter PVC sewer pipe.

**Creative Science & Research**  
PO BOX 557  
New Albany, IN. 47151  
[www.fuellesspower.com](http://www.fuellesspower.com)

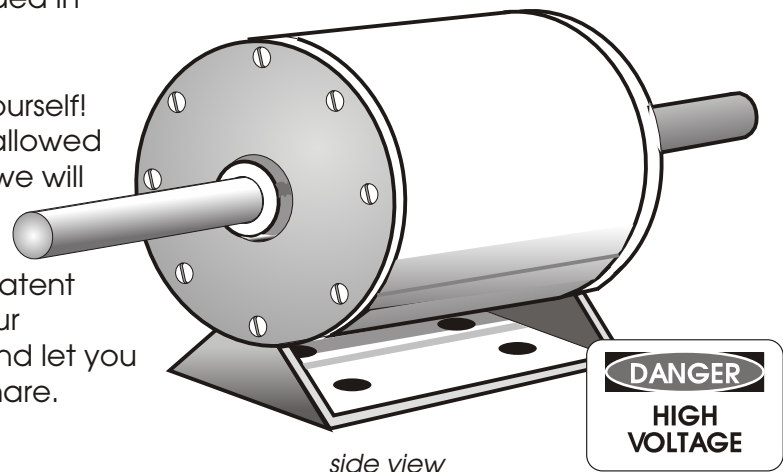
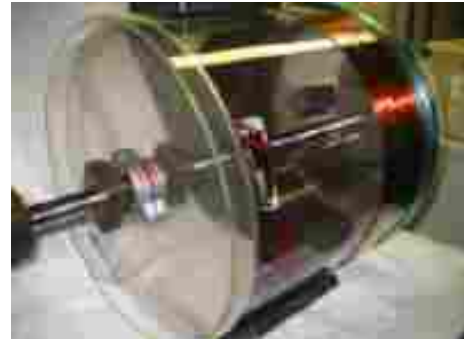

side view



COVER

4-Pole design. All magnets in the 12:00 and 6:00 positions fire at the same time, pushing apart with great force, to cause the Rotor shaft to turn. This motor can be ran in forward or reverse. This is our first prototype model and can be scaled up or down to any desired Hp you like. Of course one can improve on this design, see our #362- RC plans. We made it simple in design for those who are not educated in the art of Electric Motor building and repair. It is a good idea to study a simple Science fair DC Motor etc... To get a basic understanding of DC Motor designs. A good source is your local Library.

All HV electromagnets are wired North Pole to North Pole. They can also be wired and timed to attract each other if you wish to make an attraction motor.

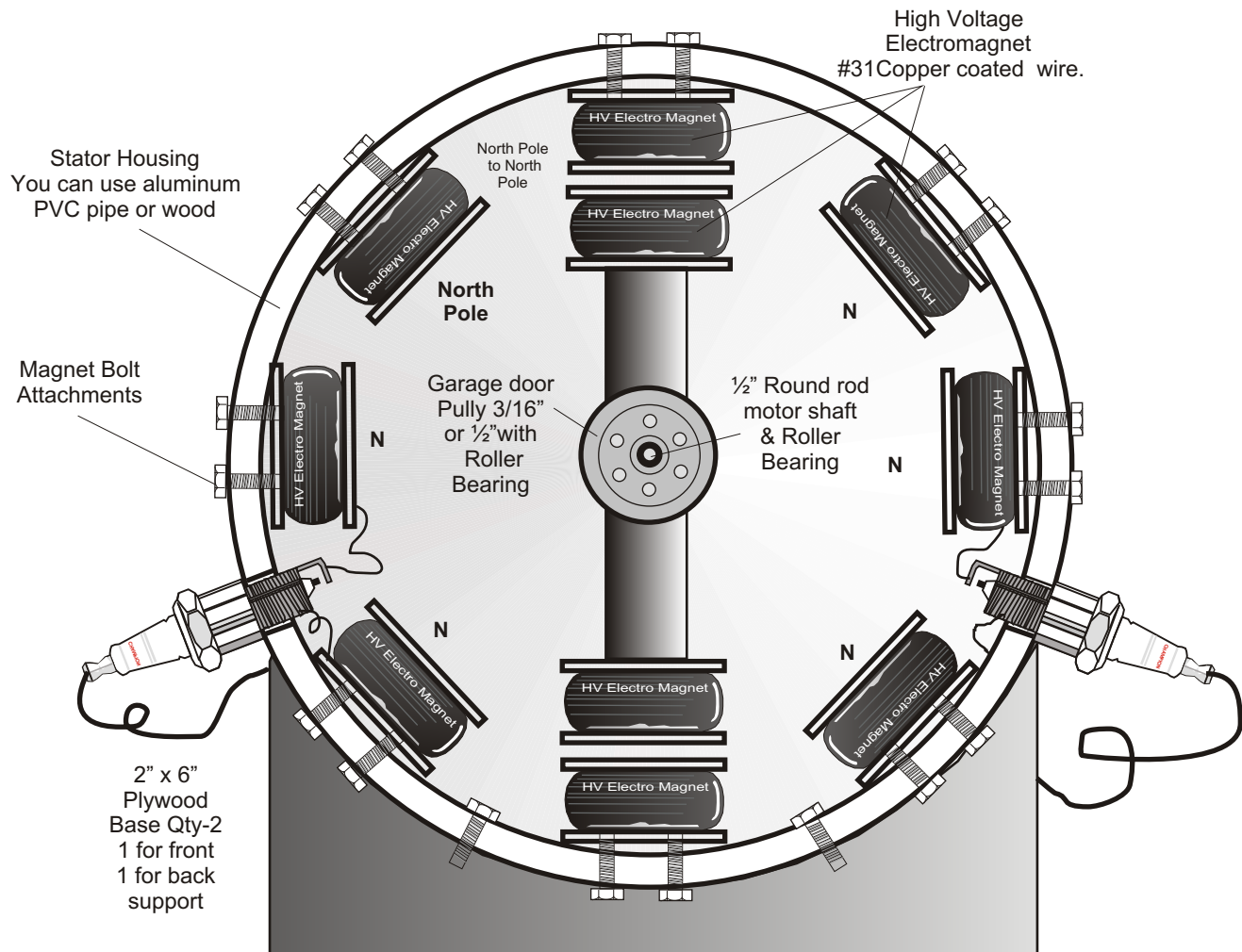

You will be using 2 - 4 spark plugs as high voltage switches, To send a DC high voltage to 4 coils at a time. You can design this engine any way you want or any shape you want, just as long as you keep to the main working principle. The motor can be as deep as you want to design it. If make the magnets or your air core magnets about 4 to 6" long, it will be much easier to turn on a slow rpm drill press. I find that wrapping the coil with #31 wire at about 150 rpms works best, 250 rpms is a little fast but can be done. We strongly suggest you first build a one Hp or less DC fuelless motor first.



In our early days of testing, we made many different types of magnet coils to run our small test motor, we left no stone unturned, we found out real fast which size wire was an amperage hog and which one proved worthy enough to be used in our free energy motor. We found that the #36 fine hair wire was the best but harder to work with. #30 copper coated wire will work, but #36 is better using thousands of winds, High Voltage and a PVC plastic Air core bobbin type coil.



" There are so many things yet to discover, so many things our eyes have not yet seen,  
We have only scratched the surface of electrical energy and free energy technology!"

" Rick " 4/1/2001

The next 1,000 years I believe, will be a self powering, free energy world! Many homes will be enjoying the comfort of free Energy which hundreds of free energy inventors paid the price for.

## The Ed Gray Engine Revealed!

We are going to reveal to you the simple secrete of the Ed gray Engine and the Fuel less Engine, The Ed Gray US Patent reveals much but not all, they left out the most important Part, what size wire to use for the high voltage electro magnets and how many turns.

I know of one customer, who was an electrical engineer; he built our Fuel less Engine with no Problem because he knew what I am about to tell you is common sense, he put his engine inside of an old caddy!

With this information you will be able to build a powerful free energy electrical motor to run a 20 kw 120 vac generator to run your home. If you use electrical heating you can also heat your home, or see our plans on the Fuel less Heater # 878PV plans and video only \$49.95 all we ask is that you keep all of this to yourself, this is TOP SECRET STUFF! Just build Them for yourself and keep it to yourself.

By buying these plans and opening this envelope, you agree to keep this information contained in these plans to yourself, you agree not to try and manufacture this engine or show a working model to the news media, unless you get permission from us. We have redesigned this engine and therefore have rights to this information, anyone trying to copy these plans or Manufacturing the fuel less engine without our permission will face legal action. #362-RC is Copy written 2002. (You can build them for your own use.)

This Engine Motor Generator is just a basic industrial HV DC electric motor that can be Scaled up or down to any power rating that you desire. But the special part about this motor /engine is it is free energy! Keep all electromagnets firing north to north. Permanent magnets can be used on the rotor instead of electromagnets, which is easier to build and eliminates the need for brushes. If using permanent rotor magnets you will need to make the motor attract.

Please don't forget to send Rick a video of your progress, he sometimes will help people if they are having any questions, by sending Rick your video you are also agreeing that he may use some of the video as promotion for other customers and research engineers to see. all video's will not be returned. If you come up with any better designs though it be big or small, it is not uncommon to get a reward. Thank you for purchasing these plans, it helps us grow as a business and a research company, we plan on having many new updates as well as new discoveries that we can share to the world.

# PARTSLIST

- Qty- 1 1,000 volt DC power supplies, 60 Hz or best 30 khz or more. You can step up the voltage by using a 115 vac power inverter 60hz modified sine wave. Use 1 high voltage step up transformer or use the capacitor and diode step up method ( see our high voltage doubler plans #379 for \$9.95 ). add enough capacitors and diodes until the voltage is 1,000 vdc.
- Qty-2 Spark Plugs, Champion Copper Plus #855 DJ7Y
- Qty- 2 12 vdc car batteries, See page 5, car batteries collect free energy back emf and also run the 1,000 vdc power supplies. The special HV magnets will be used and will only consume very little amperage in the milliamps! Batteries will last a very long time without the back emf!
- Qty- 6 or 10 high voltage electromagnets, a qty of 10 is optional, the more hv magnets the more power. I would suggest starting off with 6 magnets and adding later, turns magnets with # 27 copper coated wire, you will be turning thousands of turns, get each turn of wire as close to the other as you can. it does not have to be perfect to work. But the better you, make them the higher the efficiency!  
Each magnet core must be prepared correctly, make sure you spray each Iron core with 3 to 4 coats of clear lacquer or red spray paint and allowed to dry properly!

1/2" thick each

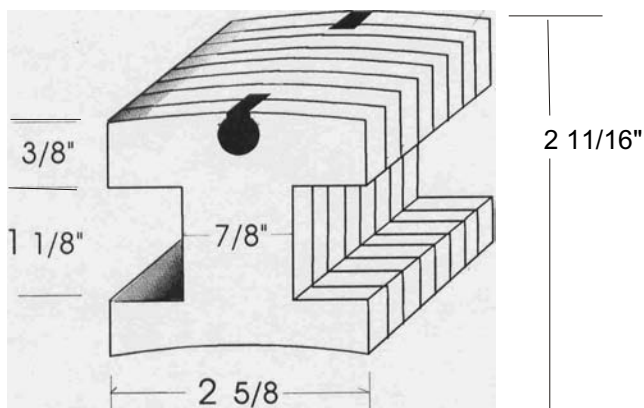

Soft Iron Core, before copper wire is applied, 4 - s+a+or magnets

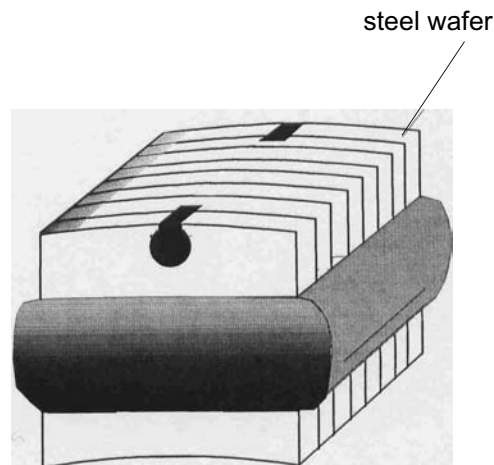

Soft Iron Core/ after copper wire is applied. Use black tope to cover.

- Qty-2 Soft Iron Ductal Bar from Industrial Tube and steel, Cincinnati, OH. 800-332-9567 , ,

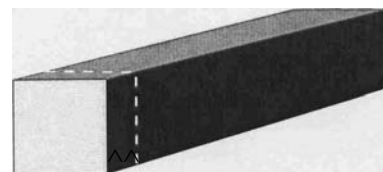

- Qty- 2 1,000 vdc capacitor and diode multiplier banks, or a HV automotive power supply. You can use all automotive HV voltage supplies like Ed Gray did on his engine if you like, it's optional. FOR MORE SEE PAGES 6,7, & 9.

# PLEASE READ

**Thank you for purchasing these plans! You will be glad you did, If you don't get it at first keep studying it really very easy to do. if your not familiar with any of the subjects in these plans please go to your library or Radio Shack and get a beginners book on electronics, electricity, electric motors magnets etc.... We have sold thousands of these plans and many of our customers have built this engine/motor. This engine/motor/free energy generator does work! If you need technical help please contact us by E-mail only, we will try our best to get back to you and help you as quick as we can.**

**To Start:** An Automobile engine can be converted into a fuel-less engine for free energy, but it should not be done! You will still have some of the same troubles a gas engine has. Such as wear and tear on all mechanical moving parts, oil rings, gaskets, pistons, etc... *too many to name!*

To do it you will need to remove the lifters and head assembly, and redesign the head. it will take two high voltage magnets per piston one attaches directly to piston via a metal angled extension and one magnet positioned on top of that one, north and north poles of magnets facing each other. Then you must hook up the capacitor banks and use the distributor timing for each piston to ignite each piston. The magnets repulse each other taking place of the explosion which takes place in a internal combustion engine. Just like any car engine you will eventually need to have it rebuilt or repaired.

**But The Fuel less Engine (motor) will never die!** You don't need a cooling system, or oil system. The only parts you will need to replace are the spark plugs *or commutators if you decide to use a commutator system*, spark plug wires and the 2 ball bearings that the shaft rides on. We estimate replacement time every 25 to 30 years. If you build your magnets right they will never break down.

This is no common ordinary electric engine / motor, there is nothing else like it that I know of in the entire world. **The output is free energy which is used to help rerun the motor by recharging the batteries. every HV Electromagnet creates it own energy after power is taken off of it. This electrical phenomenon is called Back E.M.F. , and another type of energy I can not tell you about, But for your knowledge is not needed. This free energy is converted back to the batteries to recharge them.**

**WARNING!** When working with high voltage keep out of the reach of children and adults who do not understand high voltage rules. Be careful and always wear rubber gloves when working with high voltages. High voltage can kill you. Please notice we are not responsible for anything in these plans, you build at your own risk!

## WARNING PLEASE READ!

**These plans are for your eyes only!** This invention has been suppressed by very powerful people, persons and companies that I can not reveal to you. This invention holds US Patents and these plans are protected. Copyrighted. Let me put it this way, No free energy device at this present time, 2003, can be manufactured or sold anywhere in the world. Believe me we have already tried several times and it is not worth it. But as a back yard researcher you can build discover, research and build any free energy device you want just as long as you keep it **TOP SECRET!** You can build this engine and any other free energy device we sell the plans to for your own personal use only! It would be very wise and safer for you and your family to keep it under lock and key, A good idea is to build yourself a secure Generator room that is well kept under lock and key as well as an alarm system.

Again all of our plans and videos we sell are protected! If we catch anyone reselling them or giving them away copies thereof, we will take legal action against you and anyone else involved.

You can also never show a working Free Energy device such as this one, to anyone in the news media! *I have already tried that anyway, I just caused myself more heartache and trouble. I could go on and on but there is so much I can not tell anyone! My lab and my home have been broken into many times, My phone constantly bugged! My life threatened! I have been researching free energy for over 10 years and I know from experience what I am talking about!*

**HOW IT WORKS;** THE FUEL-LESS ENGINE puts out far more than it takes to run it! It is considered a Free Energy Perpetual motion machine. It uses high voltage AC at 60 kHz ( 300 to 1,000 volts ) in the milliamps. The high voltage is then converted into DC (direct current) through the use of diodes which are rated at twice the voltage of the input voltage. Then the HV dc is directed to a HV CAPACITOR BANK, See page 1.

Without the invention of the capacitor this engine would not be possible, High voltage in the milliamps can do nothing to a HV electromagnet with out the capacitors. The capacitors quickly store the electrons and so produce a great output of *free* amperage... There is something else that we found that happens that we can not explain,.. something extra is produced by the high voltage that causes this engine to work. ?

So then the electrolytic capacitor bank is now fully charged and the spark plug gap is set to fire at 1,000 volts, It then ignites and a complete circuit is made to the magnets which are facing one another north pole to north pole, An explosive amount of magnetic power then takes place and both magnets repel one another, You can use that power to do work, to power a generator to keep up the batteries and to supply power to your entire home..

You know the first time I tried this I was skeptical, I started out using just two electro magnets that I made *myself*, We placed them on the table and I held down the top magnet just in case it did work. *I didn't want my magnet to get damaged.* So with all I could, I held *and* pressed down on the magnet with one hand and connected the + wire lead to the 12 volt battery, then **POW!** It ignited and almost broke my arm *off*, and I still couldn't keep the magnet from flying thru the air. That's an experiment that I will never forget.

It is impossible to get this much power from a low milliamp source using any other electrical DC store bought motor. **But our motor will do it!**

NOTE: The more voltage you use the more power your engine (Motor) will have, as well as rpms. But anything over 1,600 volts will have to be *well* insulated. Your *soft iron cores of your* electro magnets will have to be dipped in paint and allowed to drip dry for 3 days. Or you can simply buy a 10 LB roll of #30 or so double or triple coated copper wire.... also buy the square type you will get more power.... and be sure to wrap wire as tight as you can, side by side as close as you can...

**WARNING HIGH VOLTAGE CAN KILL YOU: DO NOT ATTEMPT TO WORK WITH HIGH VOLTAGE IF YOU ARE NOT A TRAINED PROFESSIONAL. ALWAYS WEAR RUBBER GLOVES AND SHOES, RESPECT HIGH VOLTAGE, DON'T ASSUME JUST BECAUSE IT'S YOUR PROJECT IT'S O.K..**

**ALWAYS DISCHARGE ALL CAPACITORS BEFORE WORKING AROUND OR ON THEM, EVEN IF THE AC 10 MILLIAMPS MIGHT NOT KILL, IT WILL ONCE THEY HAVE ENTERED INTO A CAPACITOR. WE ARE NOT RESPONSIBLE FOR ANYTHING IN THESE PLANS OR WHAT YOU DO WITH THEM.**

**YOU BUILD AND EXPERIMENT AT YOUR OWN RISK. SO PLEASE BE CAREFUL**

With this new knowledge you can build a Fuelless Engine or Ed Gray engine using 1,000 vdc x 10 to 30 milliamp, the capacitors (ufs ) micro farads can now be smaller, you can now use electrolytic capacitors rated at 60 to 200 micro farads and it is much cheaper to build, this brings down the cost of buying large capacitors. a automotive condenser / capacitor can also be used. you can buy capacitors that are rated at 1000 volts x 100 uf and solder them together in series, look through electronics mail order catalogs to find what you need.

By using copper coated wire #27 and winding this wire around a soft iron core, your motor will be using more voltage and less amperage! this is very important! By adding more or longer electromagnets you can increase the horsepower to any size you want, example from 100 to 350 hp.

Now back to the Fuelless Engine. EXAMPLE: by using #27 wire it is like using a small thin water hose, how much water do you think will pass through it? If you use a large 1/4" water hose more water passes through it. it is the same thing with electrons / current, the larger gauge wire you use the more amperage you will use and the less voltage you will need, this is the way most electrical motors are used today, these motors I like to call amperage hogs! They waste energy! and they are not designed to use the back emf of each coil of wire. this is a waste! The fuelless engine uses #27 wire which uses less amperage and higher voltages, which by using higher voltages you get more free energy effects!

A simple experiment will help you understand this more:

You will need two soft iron cores, the first iron core use # 18 copper coated wire with 200 turns, the second iron core use #27 copper coated wire with 2,000 turns, now you will need a 1000 vdc x 47 micro farads capacitor or capacitor bank. place a volt meter on the capacitor and charge the capacitor to 1000 volts, the negative wire of the capacitor should be connected to the coil of the first and second iron core electromagnets that you have made. now connect the plus wire coming from the 1000 v cap and connect it off and on to each magnet one at a time. as you will see the first magnet will take only 1 to 2 hits before the voltage of the capacitor hits -0-, the second magnet will take about 7 to 10 hits before it reaches the -0- voltage mark. so do you see it yet. the second magnet that is using the #27 wire uses less energy to run than does the first magnet (the amperage HOG!).



If you are on a budget you can use old wall transformer cores, you can simply use them squared off which gives you less efficiency or you cut them to the shape that you like using a high speed Black & Decker RTX rotary tool, they are small and the speeds can be adjusted, they use very small drill cutting bits etc... you can buy them at any K-mart or hardware store. Or sandwich the iron transformer core in between to blocks of 1" wood or 1.2" plywood and use a hack saw to cut them. if you do not use wood the iron lamination pieces will come apart.

The closer the magnets are the more horsepower you will have. and the longer your magnets are.

Your first model can be a 1/2 horse power motor using small 2 amp wall transformers then you can get some 10 amp large transformers from old and worn out Microwave ovens.



Using a hacksaw cut off the inside wire coil. and remove it. you will then have a E shaped iron core with a horizontal I shape glued to the bottom, you will now need to figure out the radius of the rotor so you can make a plywood shaped template, you will need one for the stator magnets and one for the rotor magnets, templates of course should be the same size as the transformers) you are using, before cutting and shaping your transformer you must place a piece of thin mdo board and tape them on each side of transformer so when you go to cut the iron laminates you will not pull them loose.

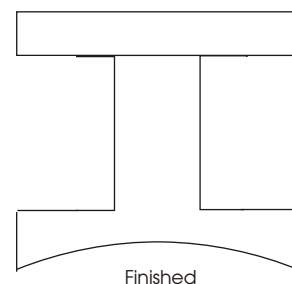
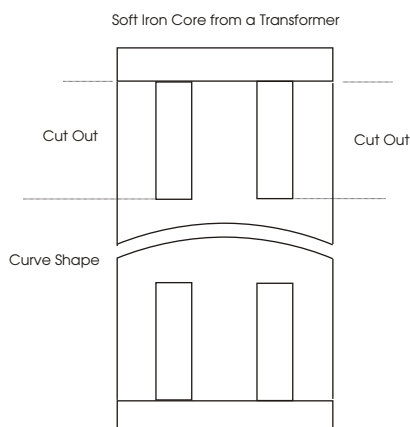

Below is a small example of what I am trying to tell you. The idea is to build a very powerful and large flywheel type engine. I would use a 30" diameter flywheel and behind it a 25" x 30" diameter deep solid aluminum rotor drum which the rotor Isolation transformers would ride on, each roll would consist of 5 transformers to increase horsepower! What I am thinking of is one monster of a motor unlike anything ever seen before. The firing sequence would be set up in almost the same manner as a DC Motors commutator would be. but the difference is you would also have a commutator much like an AC motor added to collect the back EMF, which would have an enormous output of free energy. It is so simple to design I know you electrical engineers already know what to do.

Of course you may want to stick with building the #362 model first, by cutting into the transformer laminates you are also cutting down on performance because they are shorting out, but this engine will still go produce free energy using cut out transformer cores. You may also want to customize your own iron core laminates by having them die cut to your own special shape and size and then spraying them with lacquer and gluing them together. If you have the money you can call up a supply company that carries the special soft iron sheets and have them cut up locally by a metal die cutting company, or you can call a transformer manufacture to customize the cores for you. Look them up on the web. The set up charge will be a little high but once they have the die, you can always have them cut as many as you want now or later on down the road.

High voltage electromagnets : using #27 copper coated wire with 1000's of turns

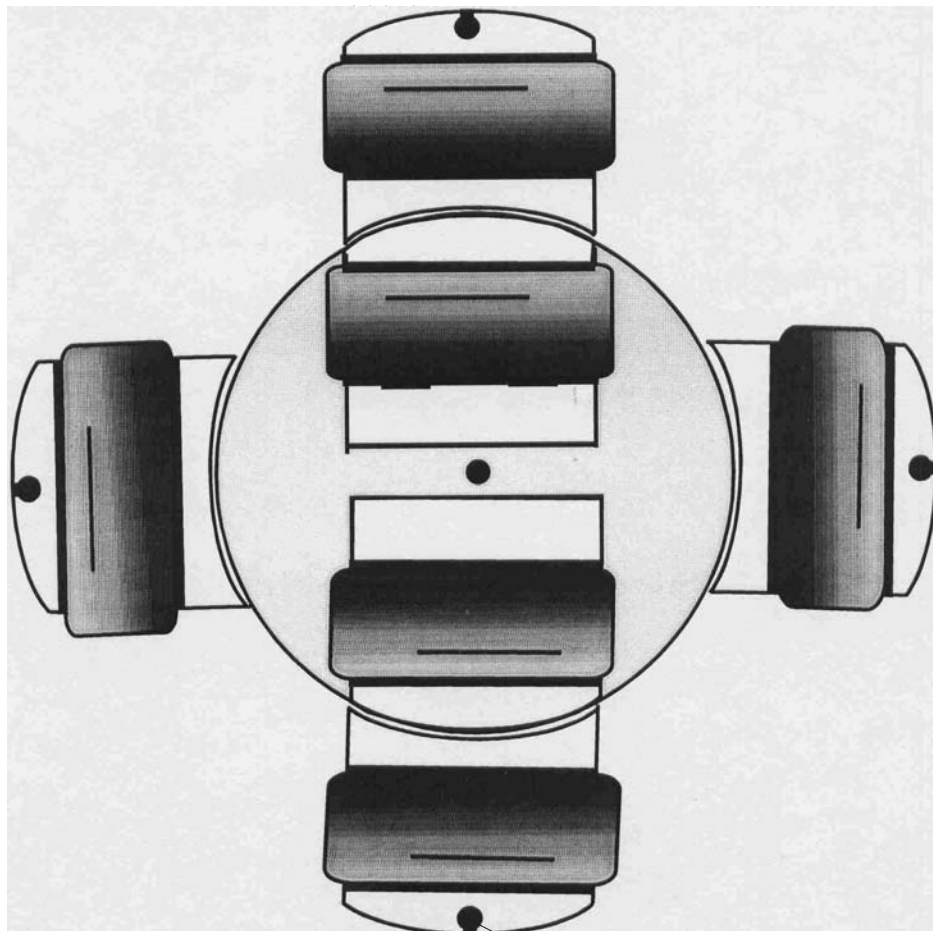

Round bolt holes to hold magnet to stator housing

#32 wire is a little hard to work with and a little hard to solder, it melts and breaks real easy. so extreme care should be taken when winding your coils as not to break the wire. if a break does happen, then you must clean the coating off the wire with a small flame first, ( a lighter) and then use very fine sand paper to clean it off. then you must use a low watt soldering iron to apply and attach both pieces back together, once this is done you must paint the connection with enamel or lacquer paint using a brush or such.

I believe it is very possible to take a high amp DC electric motor and convert it into an overunity free energy motor, I have not yet done this, but I studied it for many hours and there is no reason why you can not do it. you simply take apart the motor and take close up photos of how the winds connect to the commutator, then you unwind the (amperage hog) wires, once the entire wiring is gone you then spray the soft iron stator inside and out with the lacquer paint, use 2 to 3 coats. You must prepare the surface for high voltage or it will spark and burn out and short out your #27 copper coated wire. let it dry for 1 to 2 days then begin winding the iron core stator with the #11 wire. it may be a good idea to mark the connection of where the old wire coil began and stopped although the coil looks like one big connected coil it is not. each coil overlaps, but they are not connected, depending on the motors size, there should be about 4 - 8 separate coils, these must be replaced with #27 wire and put back into place, you must wind it very slowly by hand. (It will be very boring but keep thinking about the end result.) once all the winding is done you can put it back together and try it out. collect the back emf and then it should go over unity. ( See our plans #411 for \$14.95 plus shipping.) The end result will be a 12 volt DC motor that once ran at 12 vdc x 5 amps and ran hot, and will now run on 1,000 vdc x 10-30 milliamps! and is cold. If the back emf is collected properly the result will be a overunity free energy electric motor, replace all your motors in your house and watch the electric bill go down! and again your motors will never get hot or over heat! Back Emf is free energy from a collapsing magnetic field generated from a coil of copper coated wire wrapped around a soft iron core, pulsed by dc voltage.

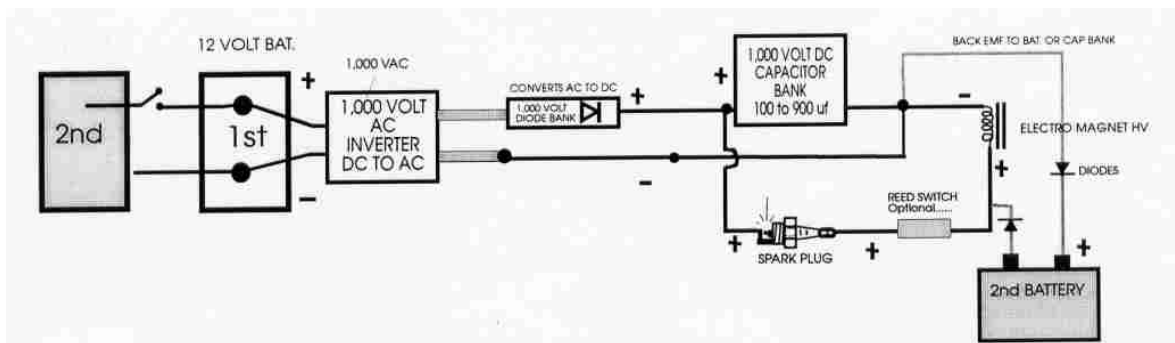

This is the Ed Gray electrical layout, every four High voltage magnet must have a 1,000 vdc capacitor bank, if you like you can try to cut down on cost by using the same inverter for all 5 hv magnets, actually I am counting the stator magnets as one even though there are 2, because they both fire at the same time. the 1,000 vac inverter is rated at about 20 - 30 milliamps.



The Fuel less Engine uses 1,000 vdc rated in the milliamps. Basically this is a large DC Motor / Generator and it works as so A 1 000 vdc Repulsive EXPLOSION! Takes place at positions 12:00 & 3:00, and then at 6:00 AND 9:00 as the rotor rotates to that position, It s like creating a lightning bolt, but using very little amperage, By using this method you get a very strong magnetic flux from the HV electro magnets and this all happens in a split second! Normally it would take a very large amount of amperage with a high voltage input to get that kind of explosive power.

The outer case ( The stator housing ) Can be aluminum pipe. See aluminum salvage yards, industrial junk yards in your area. The size and horse power can be up to you. There are laser cutting companies that will cut metal or aluminum to any size or , shape you want and it is not that expensive. The rotor plates must be cut by a laser and pieced together or hand cut and balanced on a machine shop lathe machine.

Use the illustrations below as a guide to give to your laser cutting company.

Part #1 can be a 1/4 metal or aluminum disk and can be attached to the stator housing from the edge, by drilling and tapping out holes on the edge of part#1 or you can laser cut a metal donut to fit inside the front of the stator housing and bolted into place.

If you do not know much about motors take apart an AC or DC motor and simply copy the brush contact set up.

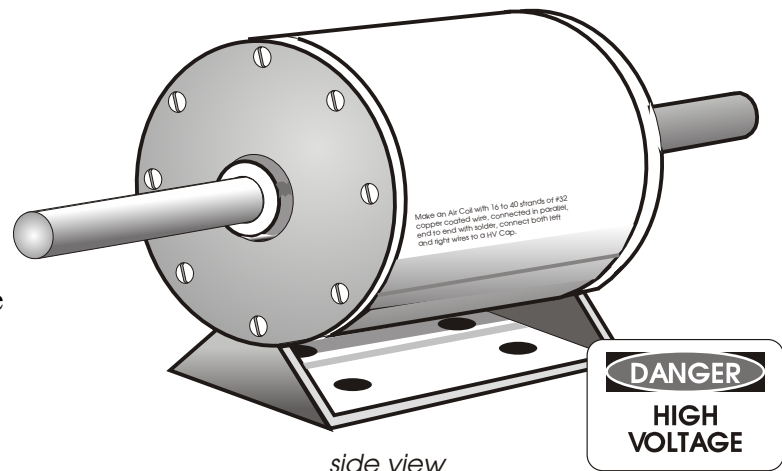

side view

Part#2  
Aluminum Stator Housing

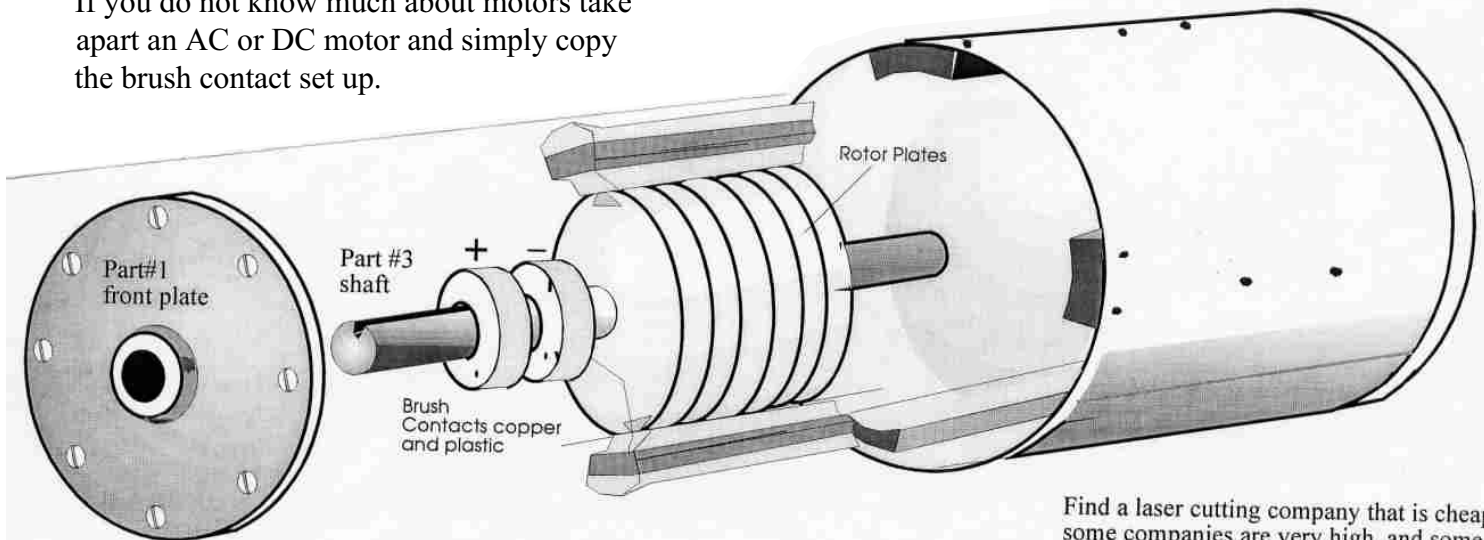

Find a laser cutting company that is cheap, some companies are very high, and some are very cheap, cost wise.

**Part #3 ROTOR SHAFT steel 1" Diameter ( Turned Ground & Polish )**

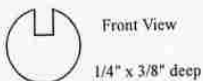

Have a machine shop cut a 1/4" square groove into your 1" diameter shaft.. ( make your shaft first before you laser cut your rotor plates.)

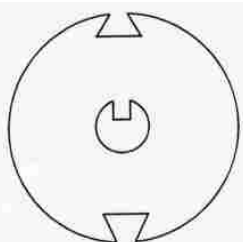

Front view  
of ROTOR PLATE

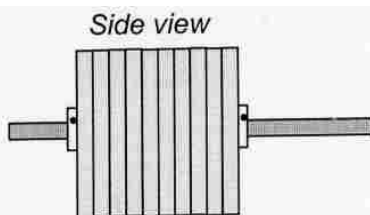

or

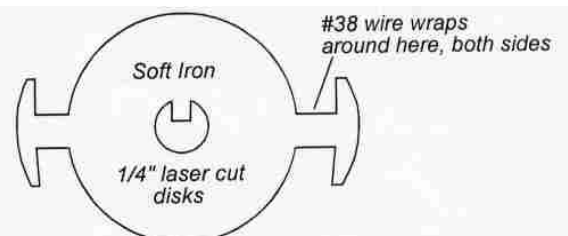

## Part #4 Rotor Plates

This is how the Rotor plates should look. It is a little expensive but well worth it if you cut them out of aluminum sheets. It is cheaper to have these laser cut using steel 1/4" plate. It will be heavy if you use 24 steel plates so you can reduce the heavy weight by cutting only 10 steel plates and using 1/2" plywood as spacers. Your brush contacts can be purchased at a hardware store or Graingers supply, or you can have them laser cut.

QTY-24 5" Diameter X  
1/4" steel

Center hole will have a 1" motor shaft going through it, it is a turned ground and polished shaft, make hole about 1 1/32"? let your machine shop decide that. ( About the size of a 1" inner diameter flange bearing would be)  
For Machinest,  
This is a special electric motor, cut b & c does not have to be critical, customer can special cut the magnet's iron core to fit your cut.

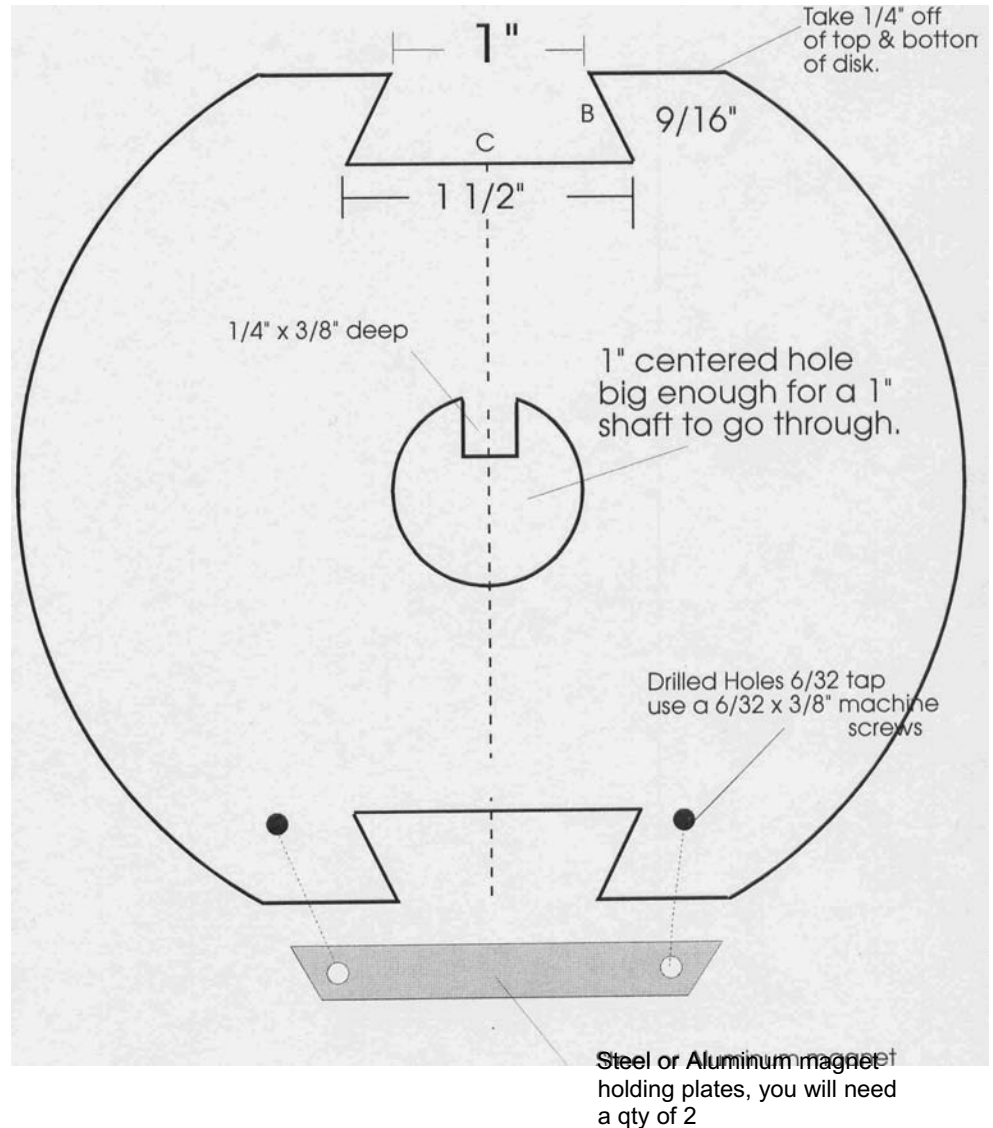

Notice: The 1" center hole of this drawing is not centered, do not photo copy, some of these drawings are not in actual proportion,

## Part # 1 Front and Back Plates

These are the front and back plates, you will need a Qty of 2. you will need to have them laser cut. you will also need to buy 2 1" pillow bearings for the center shaft to ride on.

The Stator housing can be made of 1/4" aluminum, steel, PVC sewer pipe or wood. Aluminum is BEST! our second prototype we used a 1/4" plexi housing, with aluminum block braces, the braces connected to the front and back plates, and there were 4 in all. this took the pressure off the plexi, to keep from breaking.

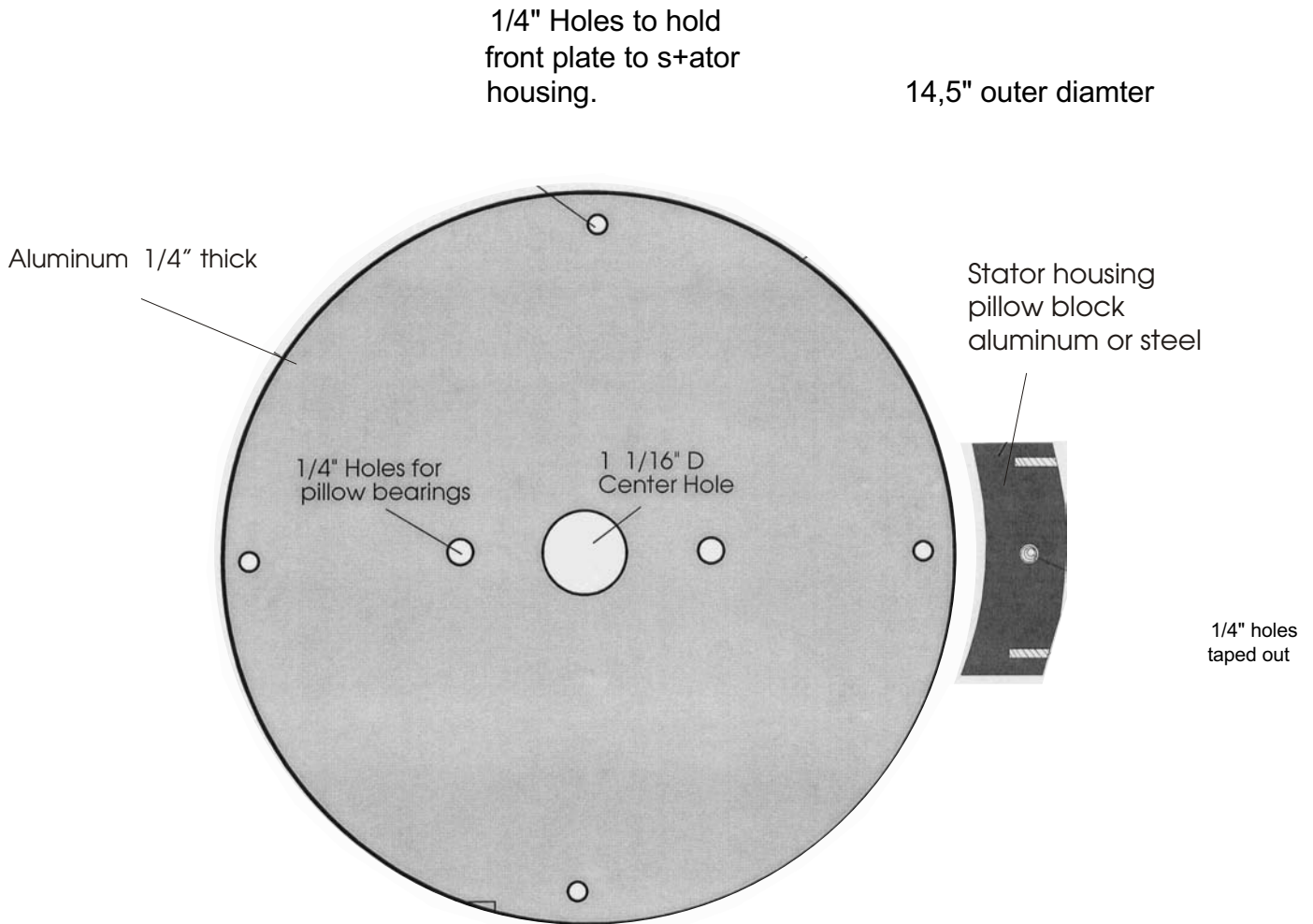

## Stator Housing

About /  
14 1/2"  
Inner Diameter

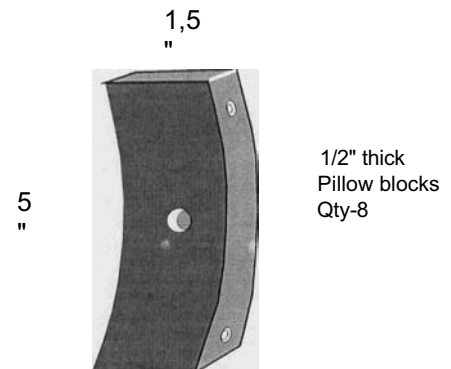
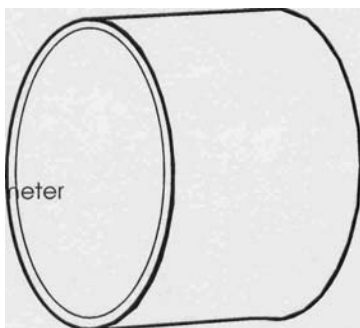

## Part # 4 The High Voltage Electromagnets

These Iron core magnets can be special cut by you or a machine shop. First you must purchase the special soft iron at Industrial Tube & Steel, Cincinnati Ohio, 1-800-332-9567 the Material you want to buy is called Ductal # 65-4512 it comes in square bars about 8 feet or so long. If I remember right, they sell it in 4" x 4" Steel Bars, to have them cut it and send it is not cheap, there maybe other soft steel out there, but we like to use this stuff, it works great, you will need to build about 6 HV electromagnets at about 4" deep so you will need to buy a bar about 24 to 30 inches in length. Once you get your soft steel bar you will need to cut it up into 1/2" square wafers, if the steel bar you bought is 4" x 4", then each steel wafer should be 4" x 4" x 1/2". You will need a miter saw or a table saw with a steel cutting disk. or it maybe best to let a machine shop cut it up for you. once you get all your wafers cut up. sand down one side of each of them until semi smooth, then paint one side of each wafer with flat white spray paint. Below you will see an example of the soft iron core you will need to shape as. you may want to get a rotor plate and make sure it will be a snug fit. Now make a steel or wood template the template should fit in the rotor plate with a 1/16" play. You will need to cut a iron core template for the rotor and for the stator, upper and lower.

Now use these templates with a pencil and trace out the design onto each steel wafer, ( The white painted side ) you will now need to cut each wafer with a steel cutting blade using a jig saw or a table jig saw. Once you are done, sand and paint each wafer with a lacquer based spray paint, (try your hardware store, clear looks better.) Leave nothing unpainted, 2 coats will be fine, let dry for 1 to 2 days, then spray each one on one side with clear lacquer , wait 15 minutes and then while the paint is still tacky, piece each 1/2" wafer together just like a loaf of bread, to make a 4" deep soft iron core. let dry for 2 to 3 hours then spray the entire assembly of wafers with the lacquer, spray on about 3 to 4 coats, let dry for 3 to 4 days before you start turning your #32 or #38 copper coated wire around them.. You can purchase this wire online or you may have a wire company in your area that sells copper coated wire, these companies sell to motor manufacture's, transformer and generator manufactures and they will also sell to you. go on the web and search for them on AOL.com or contact: EIS Louisville, KY. 502-636-0384 they will sell you this wire in small spools. You can then wind each magnet by hand or fix up a motor winder of your own. You must wind very slow or you will break the wire and it's hard to solder back together. ^--"

### Soft Iron Ductal Bar # 65-4512

1/2" Soft Iron Ductal Bar # 65-4512  
WAFER

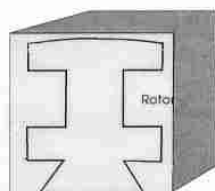

Front view

Round head bolts to go into and hold magnet into place.

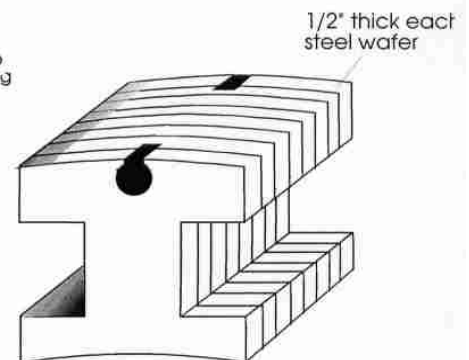
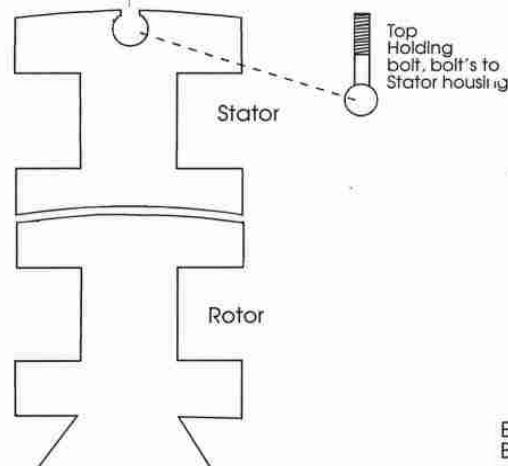

Electro magnet Soft Iron Core  
Best to use Ductal 65-4512

## How It Works:

### Ignition Stages (timing)

12:00 POSITION

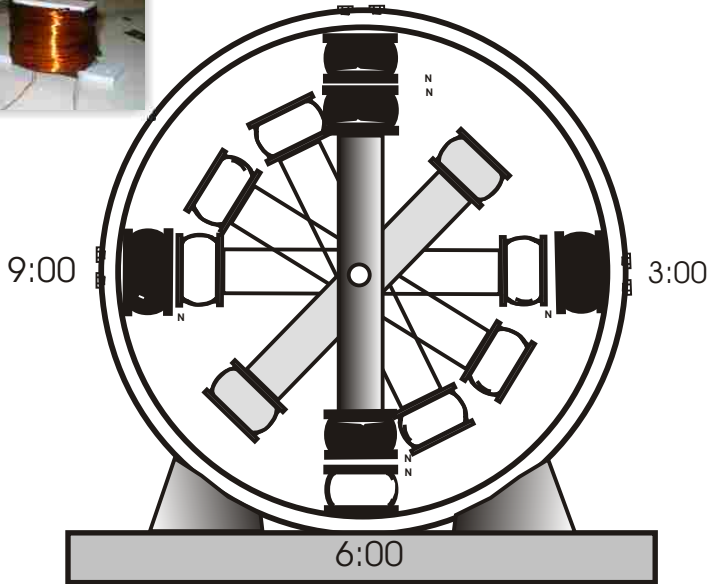

The Fuel less Engine uses 300 to 1,000 vdc rated in the milliamps. You can use a 115 vac x 500 watt inverter connected to a 12 volt dc battery, and then step up the voltage to 300 vdc or up to 1,000 vdc using a high voltage transformer or our voltage multiplier plans which uses capacitors and diodes to step up the incoming ac current.

The HV Electromagnets: Use # 27 copper coated wire. You may already have a supplier in your area for wire that they sell in spools. Check your yellow pages phone book for Electric Motor repair shops, they may sell you some or they can tell you where to buy it in your area, if you still can't find it, you can buy it on the internet, there are tons of wire companies on the net. Turn your #27 wire around an air core bobbin or a soft iron core. The more turns the better. If you do not know how to build these type of HV Electromagnets, we do sell the plans or you could try your local Library.

Basically this is a large DC Motor Generator that puts out free energy from the coils and caps. It works as so: A 1,000 vdc repulsive explosion takes place at the 12:00 and 6:00 positions, the rotor arm is then forced to the 9:00 and 3:00 positions. The 1,000 volts is switched on and off and is controlled by our easy to build homemade copper pipe commutator. When timing is adjusted just right, the inner rotor arm and shaft will spin very fast! This is much more than just an electric motor, this motor outputs free energy just as well as Solar Cells can do.

*The horse power of this motor is determined by the capacitance of your capacitors, your spark plug gap, how many Electromagnets and capacitor banks you use, and the size of your magnets*



## THE ELECTRICAL SYSTEM

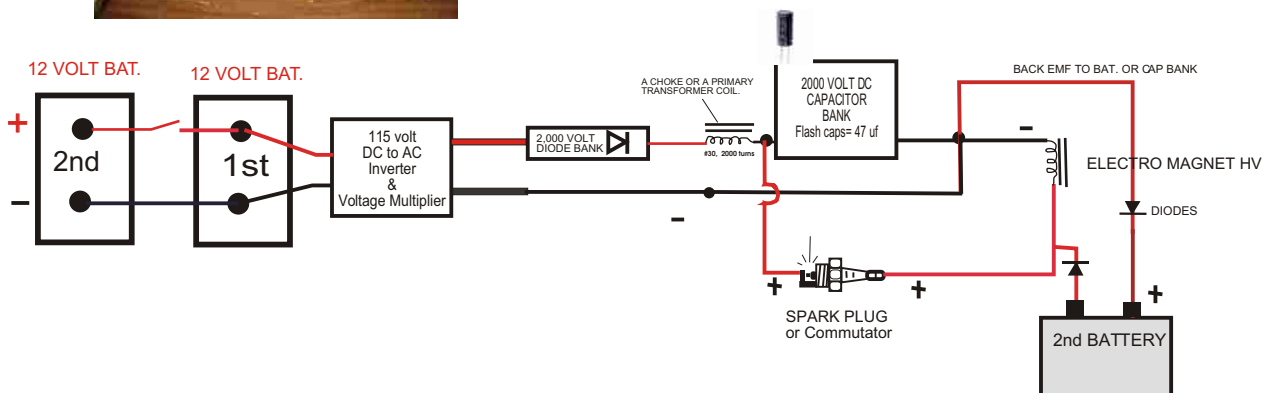



**HOW IT WORKS;** THE FUEL-LESS ENGINE puts out far more than it takes to run it! It is considered a Free Energy Perpetual motion machine. It uses high voltage AC at 60 kHz ( 300 to 1,000 volts ) in the milliamps. The high voltage is then converted into DC (direct current) through the use of diodes which are rated at twice the voltage of the input voltage. Then the HV dc is directed to a HV CAPACITOR BANK, See page 1.

Without the invention of the capacitor this engine would not be possible, High voltage in the milliamps can do nothing to a HV electromagnet with out the capacitors. The capacitors quickly store the electrons and so produce a great output of *free* amperage... There is something else that we found that happens that we can not explain,.. something extra is produced by the high voltage that causes this engine to work. ?

So then the electrolytic capacitor bank is now fully charged and the spark plug gap is set to fire at 1,000 volts, It then ignites and a complete circuit is made to the magnets which are facing one another north pole to north pole, An explosive amount of magnetic power then takes place and both magnets repel one another, You can use that power to do work, to power a generator to keep up the batteries and to supply power to your entire home..

You know the first time I tried this I was skeptical, I started out using just two electro magnets that I made *myself*, We placed them on the table and I held down the top magnet just in case it did work. *I didn't want my magnet to get damaged.* So with all I could, I held *and* pressed down on the magnet with one hand and connected the + wire lead to the 12 volt battery, then **POW!** It ignited and almost broke my arm *off*, and I still couldn't keep the magnet from flying thru the air. That's an experiment that I will never forget.

It is impossible to get this much power from a low milliamp source using any other electrical DC store bought motor. **But our motor will do it!**

NOTE: The more voltage you use the more power your engine (Motor) will have, as well as rpms. But anything over 1,600 volts will have to be *well* insulated. Your *soft iron cores of your* electro magnets will have to be dipped in paint and allowed to drip dry for 3 days. Or you can simply buy a 10 LB roll of #30 or so double or triple coated copper wire.... also buy the square type you will get more power.... and be sure to wrap wire as tight as you can, side by side as close as you can...

**WARNING HIGH VOLTAGE CAN KILL YOU: DO NOT ATTEMPT TO WORK WITH HIGH VOLTAGE IF YOU ARE NOT A TRAINED PROFESSIONAL. ALWAYS WEAR RUBBER GLOVES AND SHOES, RESPECT HIGH VOLTAGE, DON'T ASSUME JUST BECAUSE IT'S YOUR PROJECT IT'S O.K..**

**ALWAYS DISCHARGE ALL CAPACITORS BEFORE WORKING AROUND OR ON THEM, EVEN IF THE AC 10 MILLIAMPS MIGHT NOT KILL, IT WILL ONCE THEY HAVE ENTERED INTO A CAPACITOR. WE ARE NOT RESPONSIBLE FOR ANYTHING IN THESE PLANS OR WHAT YOU DO WITH THEM.**

**YOU BUILD AND EXPERIMENT AT YOUR OWN RISK. SO PLEASE BE CAREFUL**

**HOW IT WORKS CONT...** The center Rotor, Rotates with in the Stator Housing as so: after you turn it on and each capacitor bank powers up to it's firing spark potential then all you need to do is start it by spinning the shaft by hand or starter motor and lets say when you start it's in the 12:00 position it then ignites pushing it to the 9:00 position and the brush timing contacts hit and ignites all 4 magnets again pushing it to the 6:00 position and so on. Of course this all happens so fast and with so much power that you can't see it. To give you an idea about what is happening flip a bicycle on its back and spin the front tire as fast as you can repeatedly with as much power as you can. You see a little of what happens inside this engine but with 100 times more power made by the repulsion of the magnets , the weight of the magnets and rotor and the inertia. Note: the rotor can be made with just one magnet and a counter balance, it will work just fine but with less horse power. The best motor to build is the 1 hp type, which we have included in these plans. For more horse power simply scale it up. Using air core electro magnets are by far the best way to go. The finer the wire you use and the more turns of wire, the more free energy output you will have, but motor input voltage must go up. Using the fine wire will cause the motor to run with very little amperage at all, and then the Free Energy back EMF can then be used to replenish the 12 volt battery or batteries. The finer the wire the harder it is to turn. Hair thin wire breaks very easy.

## **PARTS LIST**

- 1- QTY 3,500 TO 5,000 VOLT dc to ac INVERTER 30KHZ TO 60 KHZ  
YOU CAN BUILD YOUR OWN OR WE SELL THEM ON PAGE 4  
OF OUR CATALOG.
- 4-QTY SPARK PLUGS TYPE CHAMPION COPPER PLUS 855 DJ7Y  
OR ANYTHING CLOSE
- 2- QTY 12 VOLT CAR BATTERIES OR 4 -QTY 6 VOLT BATTERIES.
- 6-QTY 5,000 VOLT DC ELECTRO MAGNETS

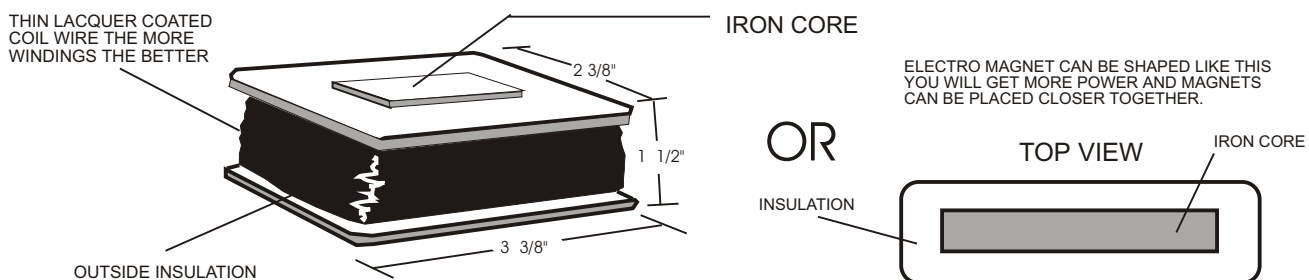

Use MDO board or some other strong thin wood for your coil bobbin, on our one horsepower motor we used 1/8 pvc sheeting, made a square center and then glues the top and bottom onto it using PVC pipe glue. Again this motor can be built using plastic pvc air core magnets or soft iron core magnets. If you use soft iron core the high voltage input has more of a chance to arc and burn out your coil.

- 8-QTY 2,000 volt diode or diode bank, check the internet for Electronic supplies.  
or you can make them your self, please send \$7.95 for plans # 4789
- 1-QTY TRANSFORMER ( USE PRIMARY ONLY ) OR CHOKE.

## PARTS LIST CONT.....

400 volt x 470 uf electrolytic capacitors. Connect each capacitor in series using a soldering iron, or you can simply buy a 2,000 v cap.

The capacitors shown here are electrolytic type. The capacitors will charge very quickly, they will not store much amperage, because the finer the wire you use and the more turns of wire you use the less amperage will be used to run the motor. There are other options, the higher the uf of the capacitor the more amps it will store. It will take longer on start up to charge, but once fully charged your cap will discharge very slowly because your motor is designed to run at very low milliamps of power.

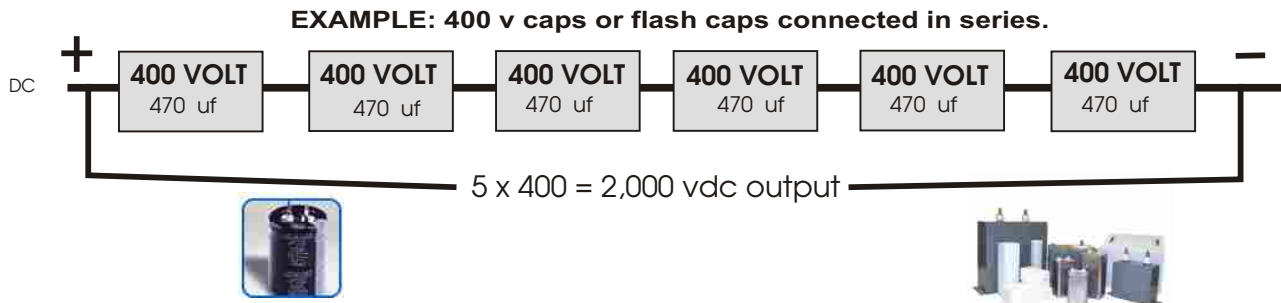

Suppliers: ALL ELECTRONICS CORP. 1-800-826-5432, INFORMATION UNLIMITED 1-800-221-1705  
CAPACITOR SPECIALIST 1-800-346-4652, RADIO SHACK ( They will give you qty prices )

2- QTY BALL BEARINGS FOR CENTER SHAFT TO RIDE ON: You will need a 3/16" bore size or what ever diameter you choose to use. we're using 3/16" but 5/8" is easier to work with since it's a standard pulley size.

In this prototype we are using a garage door pulley that we bought at a hardware store

**Bearing Co's**

Graingers louisville, ky.  
502-499-0001

Small Parts Inc. FL 1-800-423-9009

Bearings Inc. louisville, ky.  
502-637-1444

**ask them for a catalog**

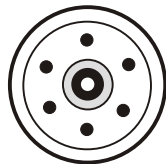

3/16"bore D x 3" D

Take your 1 1/2" stationary shaft brace as seen on the front cover and drill a 3/16" hole. Then put your shaft thru it and put on your garage door roller bearing and mark your holes where you will need to bolt to the shaft brace. Then drill your holes.

Make sure you drill a bigger hole in the first center hole you made so shaft won't drag. Also all this must be done after you apply braces to drum. Be sure you measure it right to find your center for both braces.

*Or If you decide to build a 1 hp or higher motor as on front cover, then you will need to use a 1/2" shaft with a 1/2" roller bearings.*

1- QTY ROUND ROD METAL SHAFT X 3/16" (Heat treated would be nice )

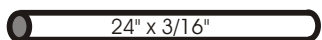

NEIL-LAVIEL STEEL CO. 502-456-2444 Or check your local phone book for metal and scrap metal co's

*If you decide to build a 1 hp or higher use a 1/2" D round rod.*

4 - QTY LARGE PC BOARDS , THIN ROSIN CORE SOLDER 1-ROLL, 100 WATT SOLDERING IRON QTY-1, FOR SOLDERING CAPACITORS AND DIODE BANKS.

1- QTY 15" DIAMETER X 12" DEEP X NO LESS THAN 1/8" THICK STEEL OR WOOD DRUM. THE ONE WE USED FOR OUR PROTOTYPE WAS A WOOD DRUM FROM A LUDWIG DRUM SET. ( This prototype is designed to be scaled up or down. )

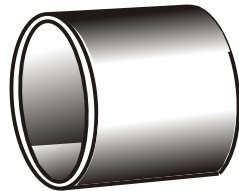

NOTE: LOOK AT METAL SCRAP YARDS (INDUSTRIAL) THEY COST ALOT LESS. THAN BUYING THEM NEW. IF THEY DON'T HAVE YOUR SIZE THEN JUST RECUSTOMIZE OUR PLANS TO FIT YOUR BUDGET. YOU CAN ALSO USE 15" PVC SEWER PIPE.

14- Nuts and bolts to hold down magnets onto drum, about 1/4" x 2"

1- 12 volt DC 60 to 100 amp generator for keeping up an inverter battery system or you can use a 10,000 watt 120 volt ac generator..

1- 8" X 5/8" ALUMINUM PULLEY GRAINGERS WILL HAVE THEM OR A HARD WARE STORE. IF YOU USE A 5/8" PULLEY WITH THE 3/16" SHAFT YOU WILL NEED BRONZE BUSHINGS OR STEEL SLEEVES TO FILL THE GAP. (OR USE A 5.8" SHAFT.)  
For larger horse power engines, use a larger diameter shaft.

1- STEEL ANGLE 1 1/2" X 36" L, THIS IS FOR YOUR MIDDLE CENTER ROTOR BRACE FOR THE SHAFT AND THE ROTOR AND MAGNETS, YOU NEED TO CUT 2 PIECES TO WHAT EVER YOUR CENTER STATOR DIAMETER IS AND THEN BEND THEM LIKE SO:

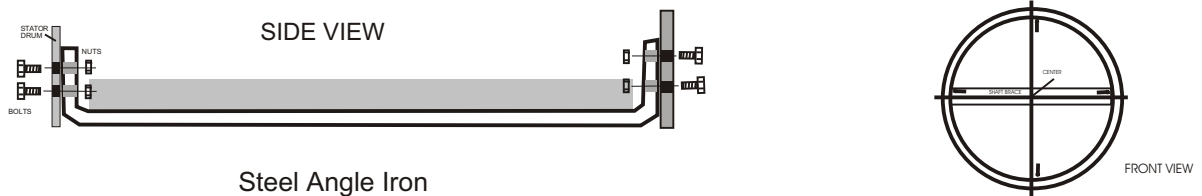

Steel Angle Iron

ATTACH TO YOUR STATOR DRUM FRONT & BACK CENTER AS WELL AS YOU CAN. THEN MEASURE IN A CROSS SECTION TO GET YOUR CENTER MARKS ON THE BRACES. THIS MUST BE AS ACCURATE AS POSSIBLE, USE A VERY SMALL DRILL BIT TO START IT SO YOU WON'T LOSE THE CENTER MARK..

1- 12 VOLT ON/ OFF SWITCH AND A ON OFF KEY SWITCH

4 - SPARK PLUG WIRES, TO ATTACH TO SPARK PLUG AND TO CAPACITOR BANK.  
YOU CAN USE THE TYPE A LAWN MOWER USES, SOLD AT HARDWARE STORES, THEY WORK BETTER.

1- 500 OR 1,000 WATT INVERTER, CONVERTS DC BATTERY TO AC 115 VOLT 60HZ to a diode and cap multiplier which in turn charges the 2,000 volt capacitor or cap bank.

1- 10 feet of small strand wire, insulated, 10 feet of red wire and 10 feet of black wire.

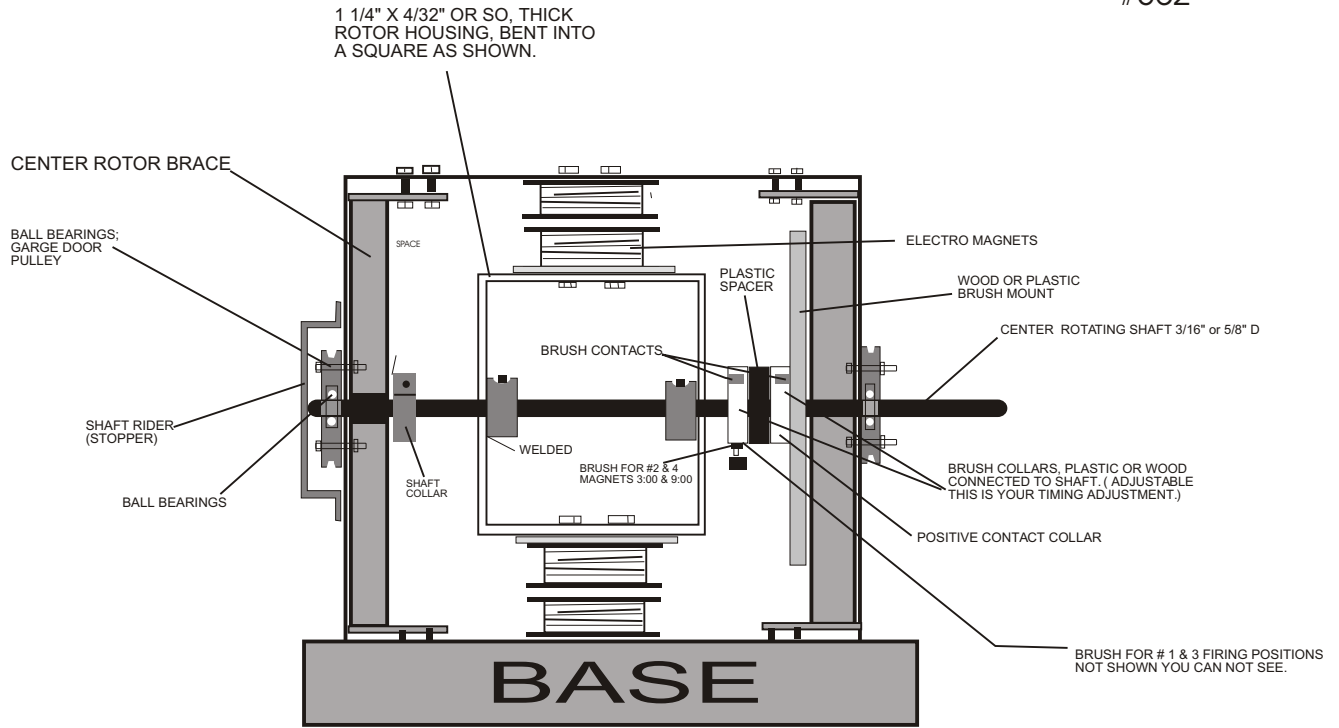

## Positive CLOSE UP OF BRUSH ASSEMBLY

NEGATIVE WILL BE THE SAME AS THIS.

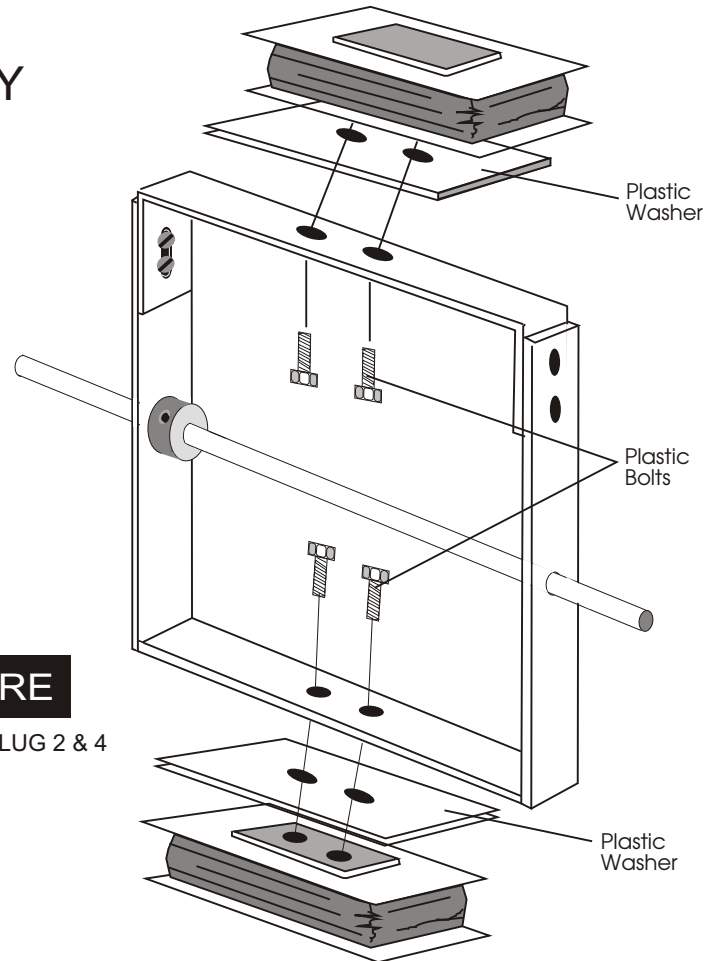
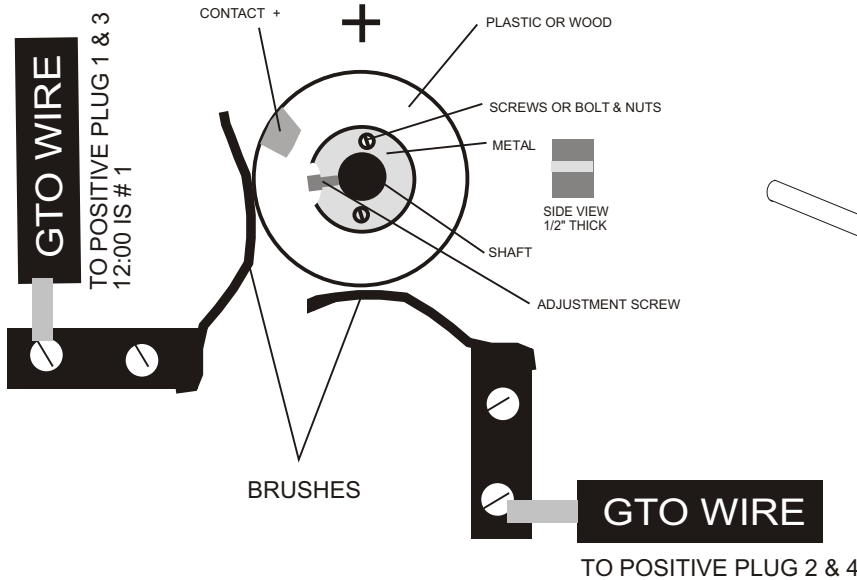

Use GTO wire to hook magnets up to brushes and any other connections were high voltage is to pass thru.

Notice: You can also design this motor to run on rotor magnets or stator magnets, using strong permanent ceramic type. It is much easier to build if you use magnets on the rotor instead of HV electromagnets.

# Timing the Fuel less Engine

#362

To get an idea of how a DC brush motor works, take apart any size DC motor and check it out. Study it carefully. Timing the Fuel less Engine: 1,000 vdc is applied to the brush assembly, the brush assembly acts as an on and off switch for each set of magnets. The brush assembly can be made in many ways. The timing takes place in two places, the spark plug caps or the commutator brush collar assembly. You will only need one 1,000 vdc charging and firing system that is rated at 1 to 3 amps, the more amps the better, but the more danger to you during assembly. You can experiment around with a low milliamp cap bank and power supply, 10 ma is safe to use. You will need two spark plugs, two sets of capacitor banks or capacitors and one or two diode banks. One diode bank is for the Positive side and optional a 2nd is for the negative side. When the rotor arm magnets #5 & 6 are in the 12:00 position contact should be made to fire #1, #5, #6 & #3 magnets all at the same time. Wire these magnets so they are north pole to north pole, or north to south which will cause motor to then be an attraction motor. Many think that an attraction motor is better? But if you are using this as a repelling motor then time the firing when the arm #5 is just 1/16" past the center of #1 stator magnet. This will insure that the rotor arm will be pushed and rotated to the left and rotate counter clock wise. If timing as an attraction motor, you will want #5 to fire at about 3 to 4 inches before it gets to #1 magnet. This motor can be times to run clock wise as well. Collect all back emf per coil using a diode and capacitor per magnet, on the negative side outputs. It is strongly recommended that you build our 1 hp motor to get more understanding of how to build this motor.

If you choose to use a spark plug, you can gap the spark plug to fire a little early which will cause your power up time to be less, But you will have less shaft torque (HP). In other words you will have more RPMs but with some what less Horse Power, Now this is not real bad because it depends on what kind of generator you're going to use.

Please NOTE: the engine must be timed just right so the rotor magnets do not repulse each other too soon. Repulsion must take place at center or 1/16" past left or right. ( This prototype uses a 115 volt AC generator, Please note: This engine design rotates to the left only, ( counter clock wise.) You can design it to rotate both ways. Also Note: A & B Magnets connect to the same + & - Brush Rotor Assembly.

Update: See our new and easy way to make a homemade commutator which should be included with these plans.

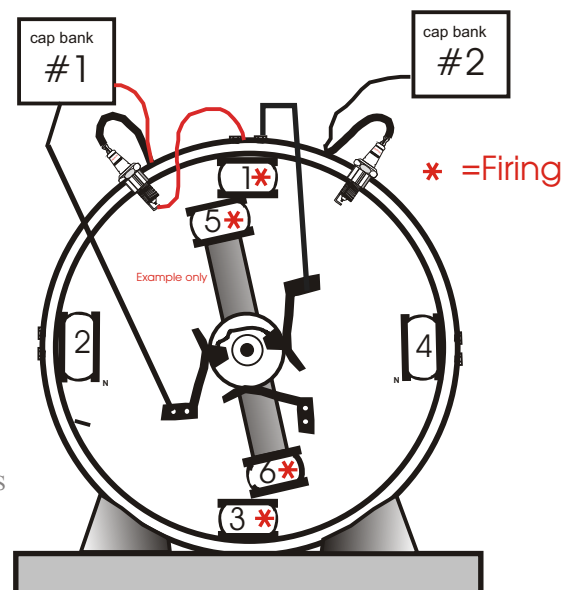
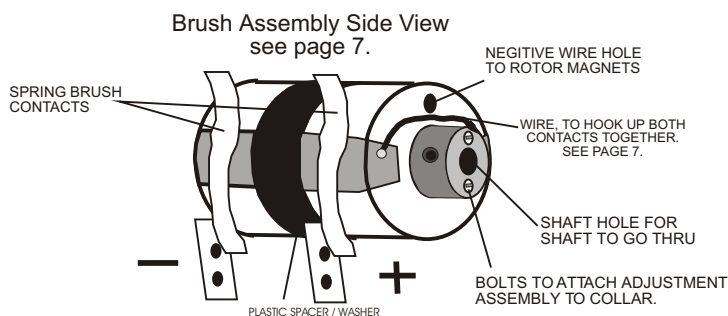

NOTICE: If you are having trouble understanding all of this, please keep studying it and do some small scale experiments to help you. PLEASE NOTE: WE DO NOT HAVE TIME TO GIVE YOU ANY TECHNICAL SUPPORT, THIS ENGINE DOES WORK, MANY ALREADY HAVE WORKING MODELS. The Library is loaded with books on electronics, electrical engineering, electric motors etc... children's books have the most for learning the 1st basics. Please do not attempt this engine unless you have some head knowledge in High Voltage and electricity. PLEASE BE CAREFUL ALWAYS WEAR RUBBER GLOVES AND SHOES WHEN WORKING AROUND HIGH VOLTAGE.

# Creative Science & Research Copyright 2002

## 785VrtxP

Our 1 hp DC Motor / For research purposes only!

Brush Assembly Part F

*Sorry Photo needs to be updated, Brushes are on wrong side, see plans.*

Commutator  
On /Off switch

*Sorry Photo needs to be updated,  
Wrong Commutator see plans.*

Powerful Ceramic  
Magnets Qty-2

Silicon or J-B Weld  
to glue 2 magnets  
to shaft.

Part " C " The Rotor Shaft

Part Q

ROTOR SHAFT ASSEMBLY

Part D & E  
Support Arms  
for Rotor Shaft

Part " M " Brush Assembly  
Holding Bar. (Steel)

Part " A " Motor Base

Part O "  
The Control Box

Part "R " Transformer Electromagnet(s)  
you will need to take apart a transformer and  
build yourself.

#16 gauge or #18 copper coated wire, used in research for  
collecting electricity from electromagnet and as a magnet it self.

**BUILDING THE  
COMMUTATOR**

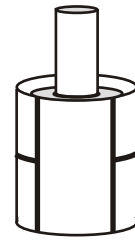

**OPTION ONE**

This is a homemade Commutator designed by Rick and Dave, This DC Commutator is used to turn off the incoming DC voltage to the HV Voltage or Low Voltage Magnetic Coil. We are going to create a junction bar that rotates and as it rotates it will slide onto the 2 carbon DC motor brushes and cause a complete connection causing DC current to flow into the Electromagnetic coil. We are going to give you 2 options in making a DC motor commutator. Pick which one is easiest for you.

**STEP ONE**

Cut a piece of 3/4" Diameter" x 1 3/8" length copper pipe that you can buy at any hardware store.

Use a pipe cutter to cut a piece 1 3/8" long.

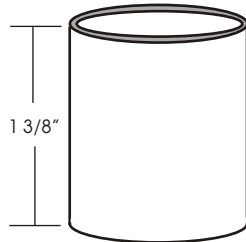

**STEP TWO**

Next using rough sand paper, sand the inside of the copper pipe really good. And then clean with laquer thinner. Surface must be free from dirt.

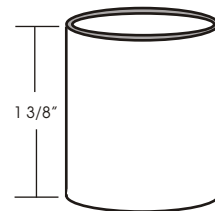

**STEP THREE**

Using a Q-Tip, Grease a piece of card board a little larger than the copper pipe diameter, this is so the epoxy will not stick to the Card board surface and can be removed when dry. You now need to fill the copper pipe with Epoxy, so slowly squeeze out enough J-B Epoxy to fill the inside of the copper pipe, follow all directions on the J-B Instructions, Mix the 2 parts very well and start placing the epoxy inside of the copper pipe. Let dry 24 hrs, I prefer to wait 40 hrs, but the instruction do not tell you that. We use J-B Epoxy because it is the best on the market and can stand up to 600 degrees.

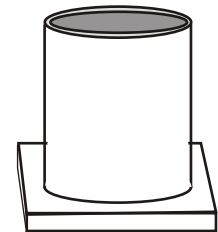
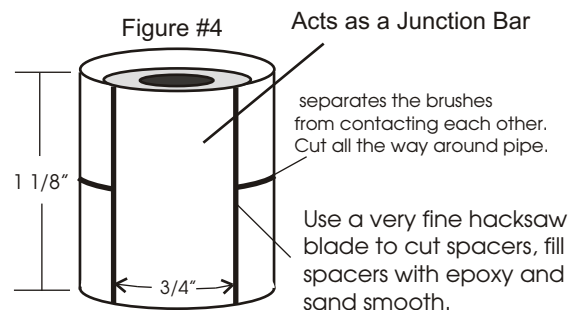

Figure #3

**STEP FOUR**

Now you must find the exact center of the pipe and score it with a sharp punch. You will be scoring or punching a small hole into the top of the epoxy. Now you are going to need a drill press. Place the copper pipe up as you see in figure #3, Make sure bottom surface is very flat, if it is not the hole will be crooked and the commutator will ride with the shaft crooked and cause a off balance at high speeds. start off with the smallest drill bit you have and work your way up until you have a hole the same size as your shaft rods outer diameter.



**STEP FIVE**

Now using a fine point marker, mark your cut marks on the outside of the copper pipe piece. As shown in figure #4. Use a fine tooth hacksaw to cut. Cut a long center cut all the way around the copper pipe leaving a 3/4" space. Cut all the way through the copper and just up to the hardened epoxy fill. Do not to deep into the epoxy fill.

Fill in the cuts with epoxy, let dry 24 hrs then sand down until smooth. Now take a 5/16" steel shaft and place it back into the epoxy hole, now place a steel 5/16" shaft collar onto the steel rod and epoxy it to the end of your new commutator, ( remove the plastic end first. )



# PART "F" BRUSH HOLDER

## ASSEMBLY



Cut two 1 5/16" x 1/2" x 1/2" x 1/16" Square steel.

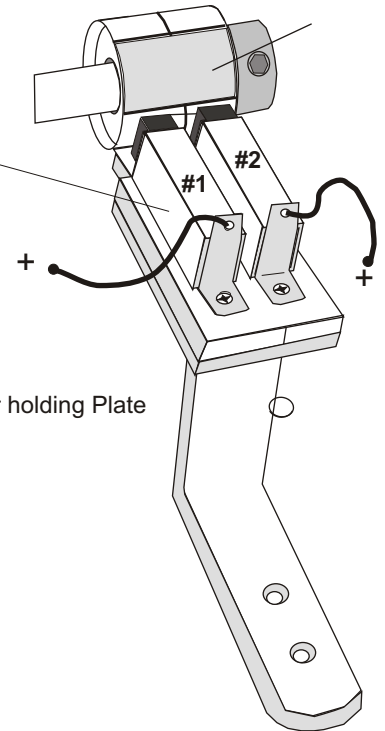
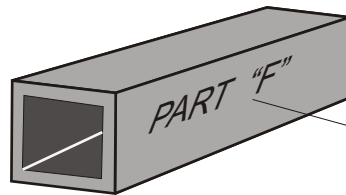
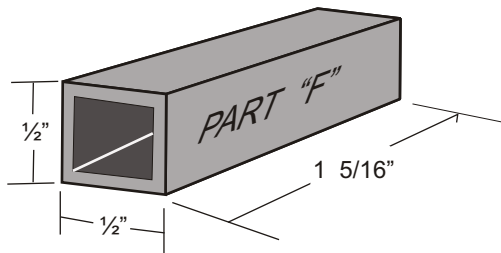

5/16" x 1/4" Motor Brush



J - B weld or PC 7 EPOXY



Copper holding Plate

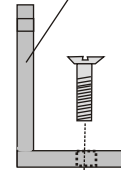

Plastic Separator

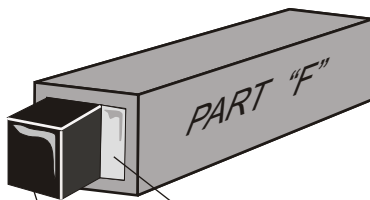

Fill with PC 7 Epoxy or J - B weld about 1/4" deep.

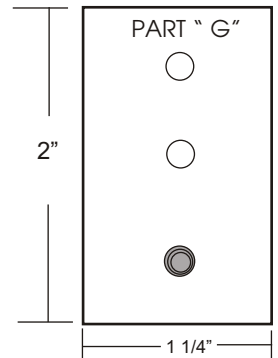
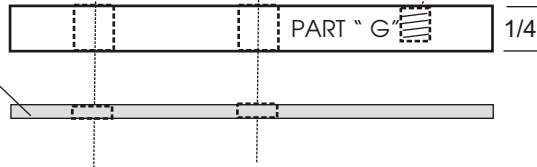

Brush: grease brush and place inside of square steel part # "F", Let sit and dry for 24 hrs, then remove brush and clean it off.

As an alternative to using brushes, you could replace with heat treated copper, which has some spring to it. Place the copper on part "M" and bend the copper upward.

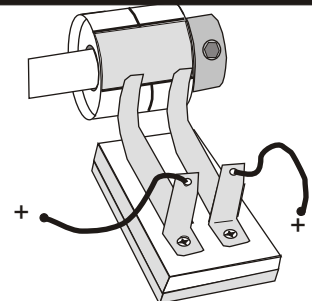

**PART "M"**  
**Brush Assembly**  
**HOLDING BAR**

Use a 8 1/2" x 3/4" x 1/16" or best to use 1/8" steel bar. This is used to hold the Brush Assembly.

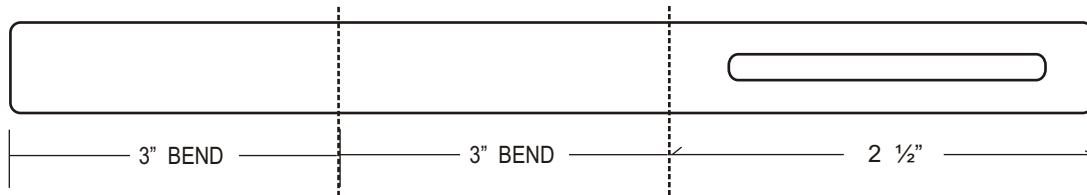

To attache Brush Assembly to holding bar.

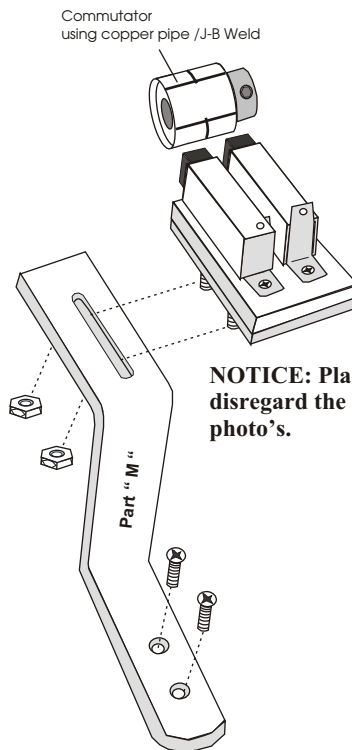
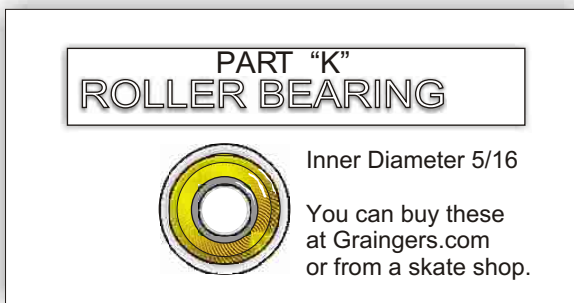

**NOTICE: Place brushes in this position, disregard the brush set up in the color photo's.**

**PART "N"**  
**SHAFT COLLARS**

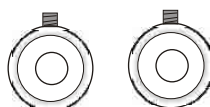

To fit 5/16" D or buy one and drill it to size 5/16"

You will need a qty of two. The first shaft collar is to hold the shaft into place, allow a 1/8" space or more between collar and Part "D" The 2nd steel shaft collar is to be epoxied ( Glued ) to one end of the finished commutator.

## PART "B" BASE LEGS

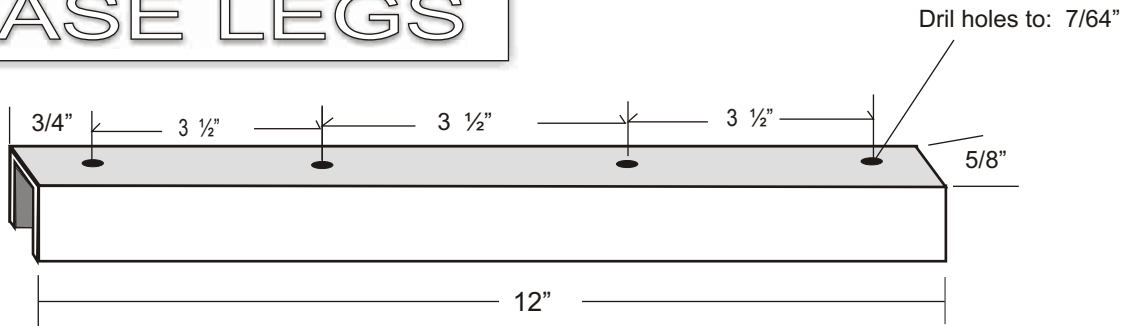

Aluminum 1/8" channel, check hardware stores, steel suppliers, lumber yards. Drill these holes at: Drill holes to 7/64". You will need a qty of - 2. You will need to tap out each hole, ( Thread it ) using a 6-3 NC tap plug style.

## PART "C" ROTOR SHAFT



5/16" steel round rod

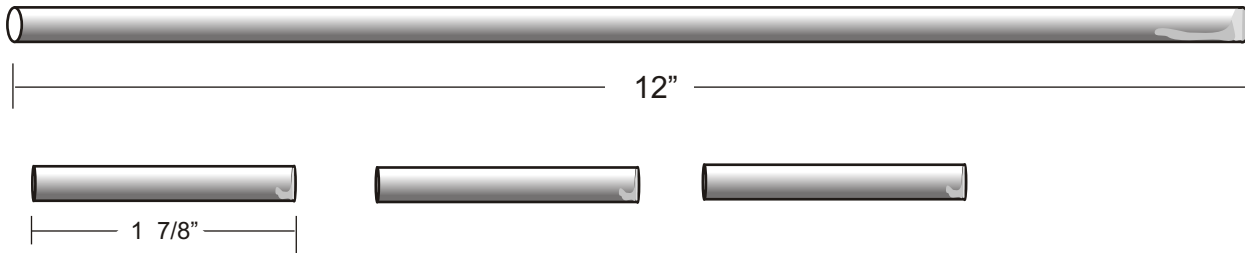

You will need three short pieces, two for the magnets to be used as spacers and one for a Shaft mold for making Commutator.

## PART "D & E" ROTOR SUPPORT ARMS

Use 1/2" aluminum bar. Check at: Machine shops, Steel suppliers in your Yellow Pages, Steel salvage yards etc... Drill two holes on each arm, use a 5/16" drill bit. After you install roller bearing assembly on part " D ", remove roller bearing and drill a bigger hole using a 11/32" drill bit. On Part " E " Drill only halfway through, so the 5/16 rotor shaft can turn on it.

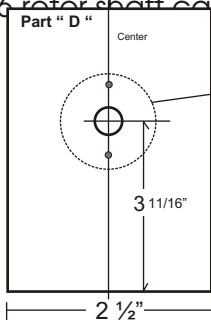

Roller bearing assembly, Use a large steel washer, assemble this after you put the Rotor shaft and arms together Once your shaft is running through Part " D " hole, you can then place the Roller bearing onto it. Grease the outer part of the bearing. Predrill 2 or 3 holes in the large steel washer, place the large washer over top of the roller bearing, center and mark your holes, use a 7/64" drill bit and tape out your holes with a 6-3 NC tap, then attach the washer to Part " D " with 6-32 x 1 1/2" bolts. Now mix up some J-B weld or Pc7 Epoxy and fill the inside beneath the washer and all around the roller bearing. ( Make sure bearing is greased well so you can remove it to later drill your larger hole. The reason you need to drill a larger hole later is so your rotor shaft can turn more easily. Let epoxy dry for 24 hrs, then remove your Steel washer roller bearing plate, then remove your roller bearing, drill a bigger hole in Part "D" then place you bearing back onto the molded roller bearing assembly.

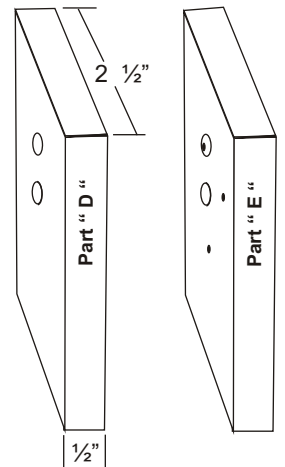
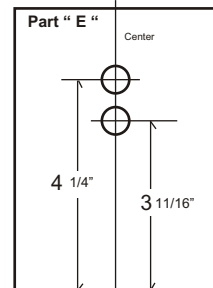

This is a research device, Capacitor and diode ratings depend on the voltage input vs what size coil wire used and # of winds. If you use a coil that is wound several thousands of times with number 38 or 36 copper coated wire, you are going to need to use voltages from 1000 to 3,500 vdc input. The back emf will be great. # 38 wire is hair thin and hard to wind but it is the best to use for a PVC air core type magnet.

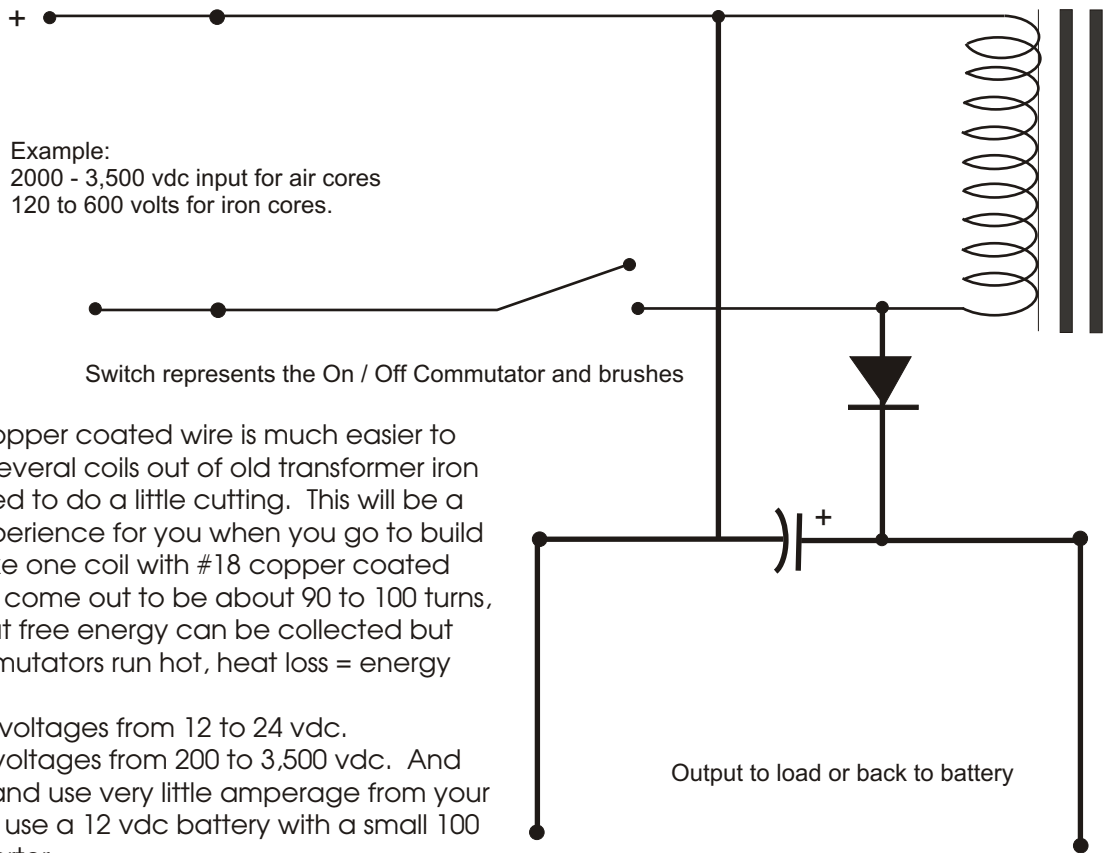

Using # 36 or 32 copper coated wire is much easier to work with. Make several coils out of old transformer iron cores. You will need to do a little cutting. This will be a great learning experience for you when you go to build a larger unit. Make one coil with #18 copper coated wire which should come out to be about 90 to 100 turns, you will notice that free energy can be collected but the coil and commutators run hot, heat loss = energy loss.

# 18 wire will take voltages from 12 to 24 vdc.  
#38 wire will take voltages from 200 to 3,500 vdc. And will run very cool and use very little amperage from your DC power supply, use a 12 vdc battery with a small 100 watt dc to ac inverter.

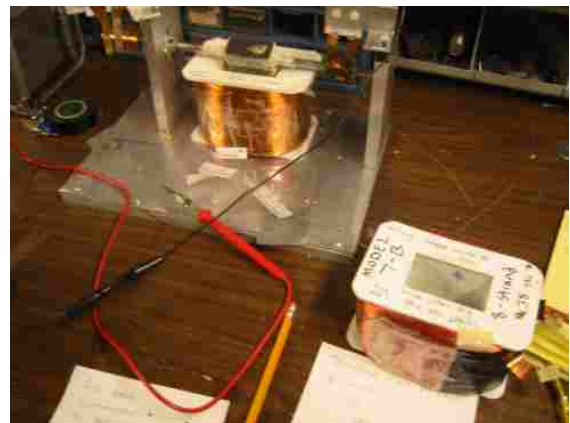

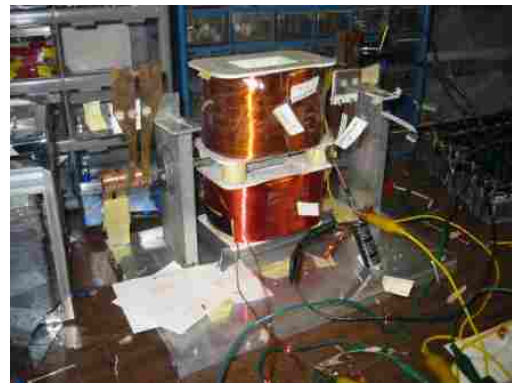
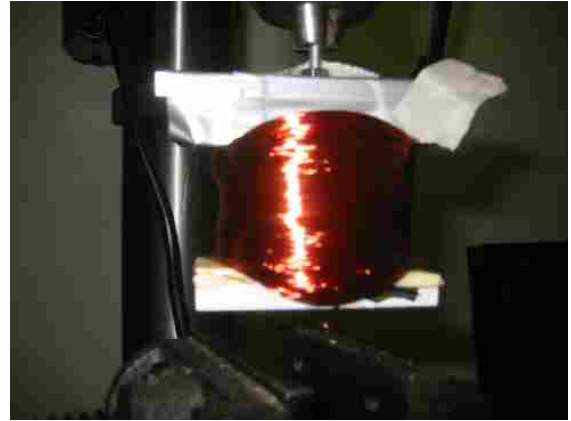

PART "P"  
**COPPER COATED**  
 Magnetic Wire

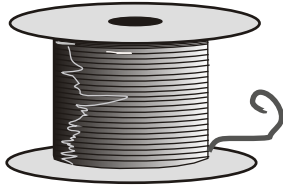

You will need 3 different rolls of wire.  
 # 16 or #18 gauge, # 26 or close to,  
 # 36 or # 38 hair thin wire.

You will need Copper coated wire to wrap around your soft Iron Cores, You will want to build up to 4 different Electromagnetic Coils with different size wire for study and research purposes. Teachers show your students the different effects and outputs that this Motor Generator will make by using more turns of wire vs less turns and the wire size. Make your Magnets interchangeable. Collect the Back Emf to and use the Vortex Effect to show your students how to get Free Energy out of these motors.

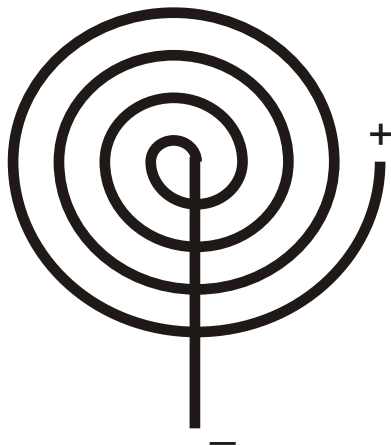

Use #16 gauge or #18 Gauge copper coated wire to make a Spiral. demonstrates an amperage hog motor, Place this Spiral under the motor shaft. Run test and note what happens.

To make a Spiral coil, use two pieces of flat plexi glass or MDO board, drill a center hole in both, sandwich the 2 pieces together leaving a metal or cardboard spacer in between the 2 boards, the spacer washer must be the same size thickness as the wire. Now place a bolt in the center hole and attache a nut. Now drill a small hole nest to center hole so you can run the first part of your wire through, tape it down and begin turning wire.

Reversing polarity reverses the poles.

Produces a strong magnetic force without the use of a middle soft iron core!

PART "Q"  
**CERAMIC MAGNETS**

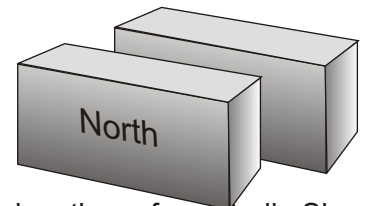

For this motor you will need 2 powerful ceramic permanent magnets, you can buy these from Radio Shack or search the internet for magnet suppliers. If you want to increase your horsepower then you must add more magnets to your shaft, on this motor you can get 2 pair. Make sure to redesign your magnetic coil structure to be longer. You can also design a large HP motor with Radio shack magnets by buying a hex shaped metal rod,  and glueing 24 magnets to it. This will also

Insure that your permanent magnets will last a very long time.

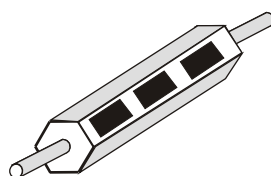
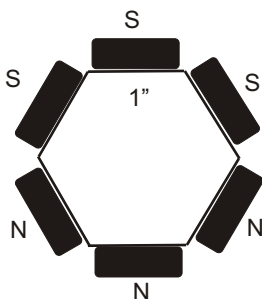

For the more advanced: Use a aluminum or steel Hex Bar, have a machine shop round off the ends to fit your end bearings. Epoxy each magnet onto the hex bar. Example length, 18 3/8" long. Use 1" hex flats. This will make for a very powerful free energy motor.



# A letter sent in by a customer

To the technician  
at Creative Science,

After studying your file, "The Fueless Engine" I Downloaded, from the internet, a copy of U. S. Patent # 3,890,548 for further study. These devices, as stated, appear to work by the conservation of energy, and the electromatic coupling of energy, while collecting the electron moving forces of decaying magetic fields after physical work as been accomplished.

On page 8 of your file yhou state that you would apperciate any new ideas and findings. It seems easier to understand how this engine works with the concept of inductance in mind. Your file arranged like this might be easier for the layman to understand.

I noticed in the descriptions of the illustrations in Ed V Gray's patent, something that wasn't apparent at firsts. Number 32 in figure 1; is a second complete charging system! That leaves me to believe that power might flow through the system like this.

## POWER ROUTE

Figure 1

Sub Figure

10	Battery one	Battery two
16,20	Charging system one	Charging system two
21,21a	Diodes(bottom of sine wave 21a)	22,22a Diodes(top of S. wave 22a)
23	Choke coil	24 Choke coil # two
26	Capacitor bank	25 Capacitor bank
28	Inductor(Magnets) E.M.F. to battery two	27 Inductor(magnets) E.M.F. to battery one

In Ed V Gray's diagrams: see figure one; The sinewave(s) are split differently, see sub-figures 19a, 21a, 22a. This might be what he considers, "splitting the positive." He uses diodes (#'s 21 & 22) to rectify the positive's of two opposite, unidirectional sinewaves.

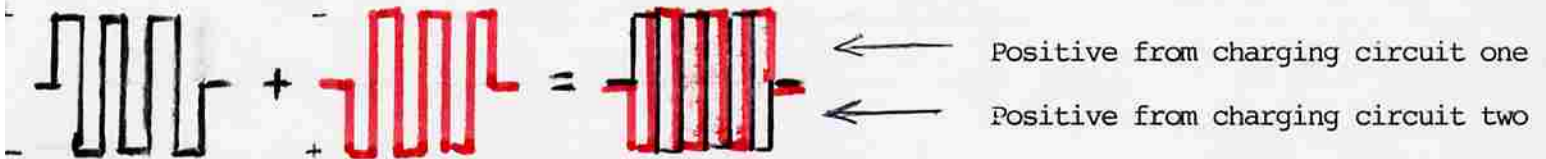

In my opinion the negative waves of these currents are transformed/harnessed as flux. The Inductors(#'s 23 & 24), along with the inductance of the magnets could influence the way the flux reacts in nature/reality. Splitting the positive(s) and exciting the currents into flux seems to be where the efficiency is achieved.

Your simplified model is sound in theory. However, the illustrations don't contain any reference to the DELAY COLLS/INDUCTORS of the charging systems, nor to the important role they play in the system. As I understand it, when current is increased in an inductor, the inductor generates a counter E.M.F. which opposes current build up. As current decreases, the inductor sets up a counter E.M.F. to try to keep the current going the same way. This is accomplished by the magnetic field expanding and contracting in the core of the inductor. This concept tends to cause the power to be "OUT OF PHASE". Ed Gray states in his patent, "which is believed to produce a static floating flux field." The word static, may be a reference to the way power flows at a molecular level. In the delay coils the inductance also seems to be applied as a flux(magnetic field? or?) and as a phase variant in how it interacts with other inductors (stator and rotor electromagnets). The floating part of it?? Hence, "static floating flux field". In the magnets power and current being out of phase seems to be how Ed V Gray has been able to recover so much energy. This may also help illustrate, "that something extra that is produced by high voltage that can't really be explained.



\*362

[54] PULSED CAPACITOR DISCHARGE ELECTRIC ENGINE

[75] Inventor: Edwin V. Gray, Northridge, Calif.
[73] Assignee: Evgray Enterprises, Inc., Van Nuys, Calif.
[22] Filed: Nov. 2, 1973
[21] Appl. No.: 412,415

[52] U.S. Cl. 318/139; 318/254; 318/439; 310/46
[51] Int. Cl. H02p 5/00
[58] Field of Search 310/46, 5, 6; 318/194, 318/439, 254, 139; 320/1; 307/110

References Cited

UNITED STATES PATENTS

Table with 4 columns: Patent Number, Date, Inventor, and Reference Number. Includes entries for Spencer (318/194), Brunt (318/194), Roberts (320/1), and Phinney (307/110).

OTHER PUBLICATIONS

Frungel, High Speed Pulse Technology, Academic Press Inc., 1965, pp. 140-148.

Primary Examiner—Robert K. Schaefer
Assistant Examiner—John J. Feldhaus
Attorney, Agent, or Firm—Gerald L. Price

[57] ABSTRACT

There is disclosed herein an electric machine or engine in which a rotor cage having an array of electromagnets is rotatable in an array of electromagnets, or fixed electromagnets are juxtaposed against movable ones. The coils of the electromagnets are connected in the discharge path of capacitors charged to relatively high voltage and discharged through the electromagnetic coils when selected rotor and stator elements are in alignment, or when the fixed electromagnets and movable electromagnets are juxtaposed. The discharge occurs across spark gaps disclosed in alignment with respect to the desired juxtaposition of the selected movable and stationary electromagnets. The capacitor discharges occur simultaneously through juxtaposed stationary movable electromagnets wound so that their respective cores are in magnetic repulsion polarity, thus resulting in the forced motion of movable electromagnetic elements away from the juxtaposed stationary electromagnetic elements at the discharge, thereby achieving motion. In an engine, the discharges occur successively across selected ones of the gaps to maintain continuous rotation. Capacitors are recharged between successive alignment positions of particular rotor and stator electromagnets of the engine.

18 Claims, 19 Drawing Figures

200 HP

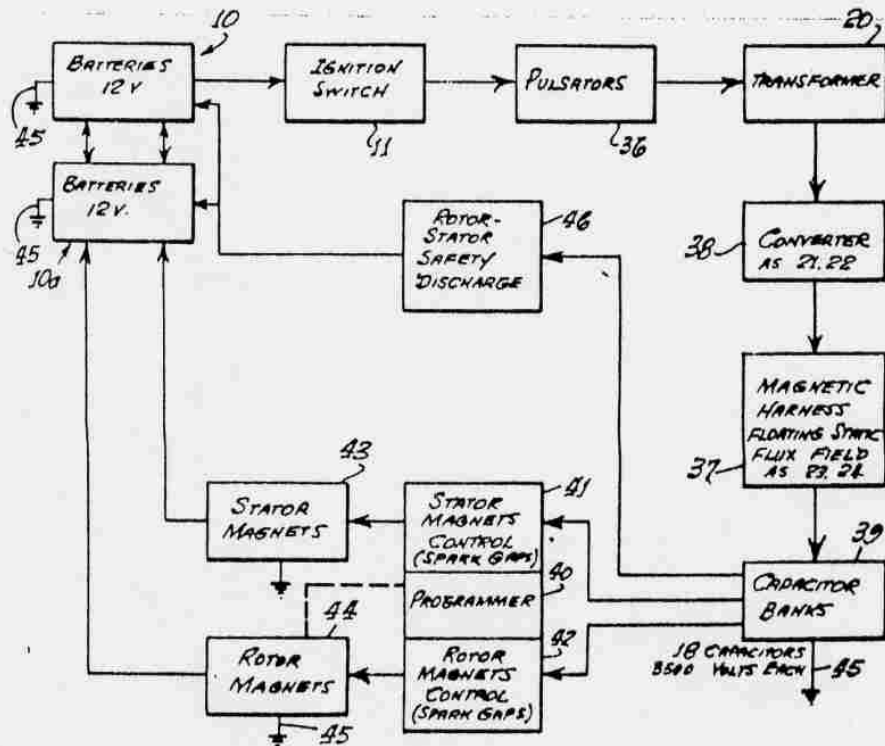



FIG. 8.

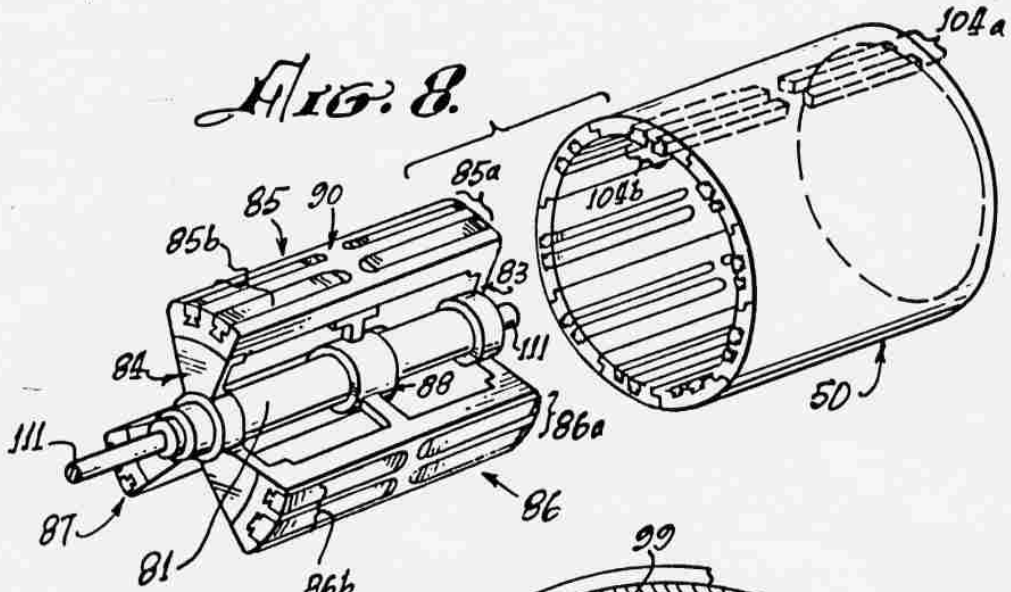

FIG. 9.

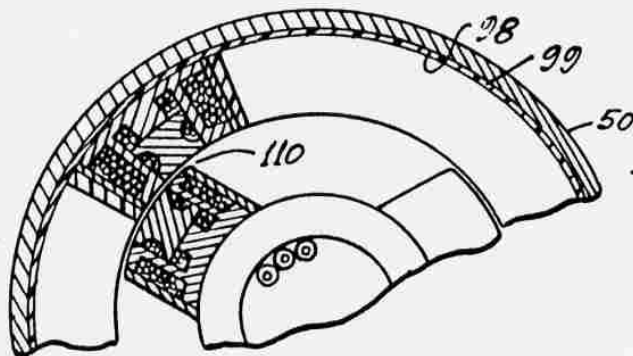
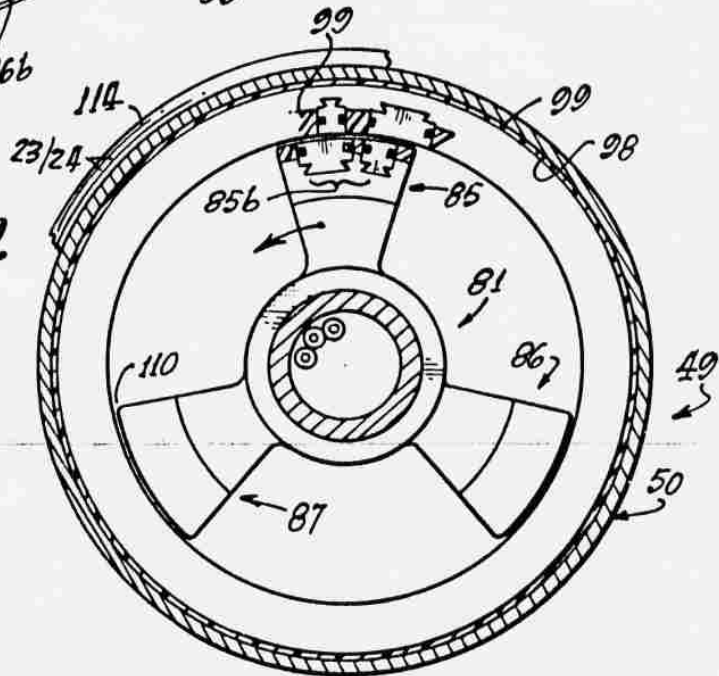
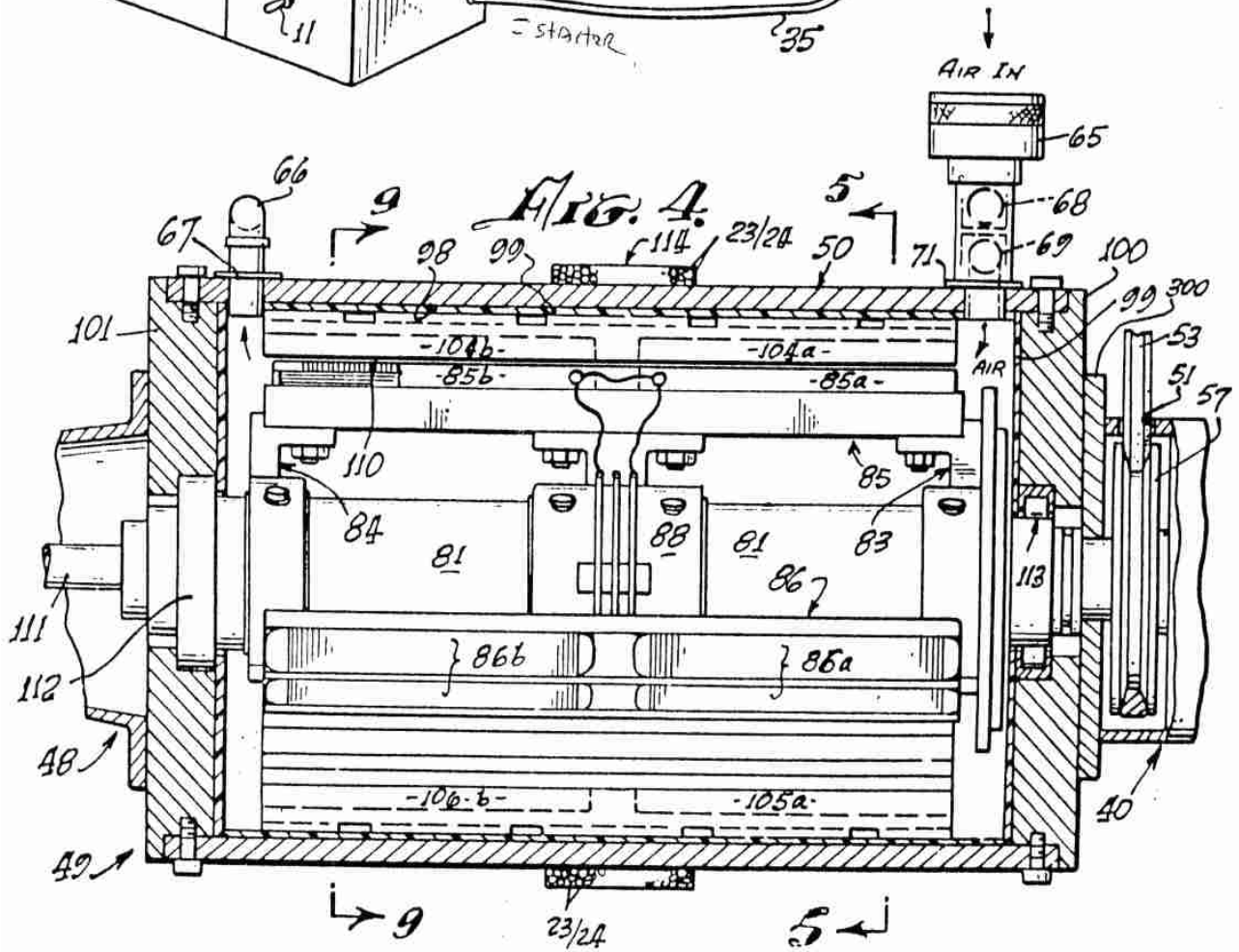
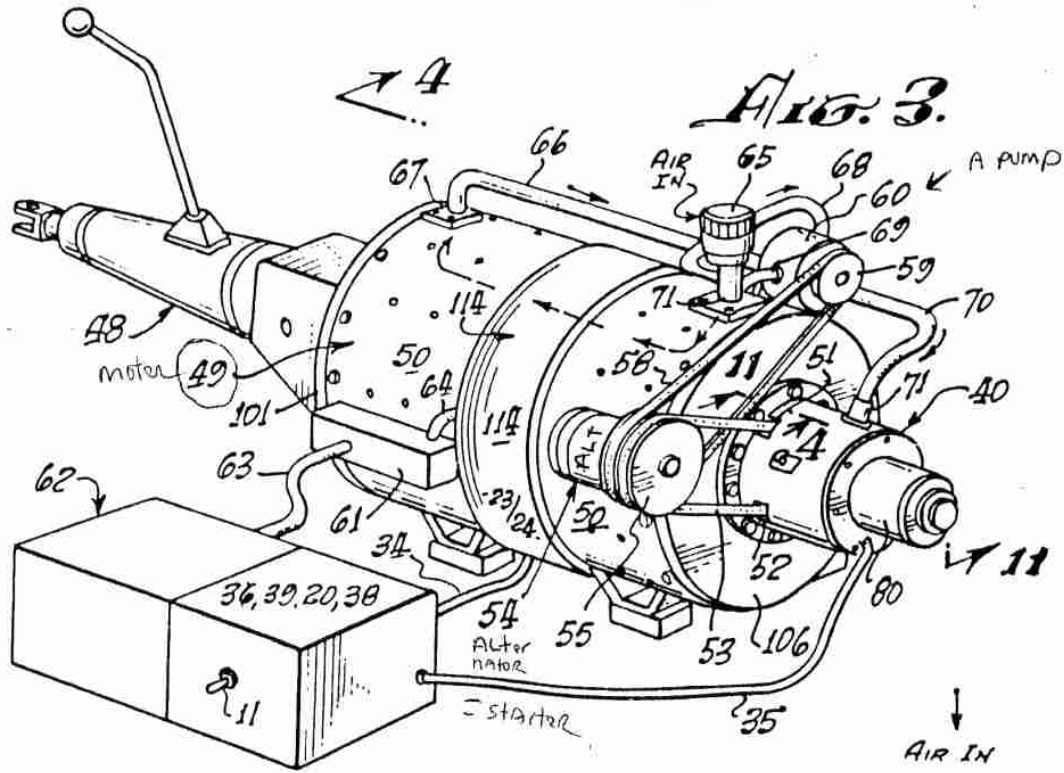

FIG. 10.



"magnetic vacuum," created in the drum, which literally takes the pressure off of end bearings and allows the rotor to float within the drum.

The motor created power surges—one behind the other—in micro-seconds. This allowed them to direct the magnetic flux field. The magnetic flux was a coolant source, so it did not need a cooling system.

The EMA's noise emission was far less than that of all other power sources, and Gray claimed there would be no increase in noise as the engine aged. In fact, electric-motor noise is almost imperceptible when properly suppressed.

The only external magnetic effect was that another field system couldn't operate within the same battery system. The magnetic field orientation is 360° in all directions.

### Perpetual Motion?

According to EvGray, some experts believe the EMA is a perpetual-motion engine—that is, machinery that would produce continuous movement without any outside energy source—and is, therefore, invalid. The very concept of perpetual motion violates all known laws of thermodynamics.

Gray himself refutes this belief.

*The EMA motor is definitely not perpetual motion. Only those in the scientific world who understand the theories of physics are able to comprehend how our motor works. There's only a handful of such persons.*

## EMA-4 MOTOR PRELIMINARY TEST DATA

Input Power	12V dc (or a 24Vdc system using a 12V standard starter motor)
RPM	2550 RPM constant
Torque	66 lbs/constant
Horsepower	100 HP
Brake Horsepower	32.05
Foot-pounds/minute	1,057,650
Foot-pounds/second	755lbs (include 110 lbs for four TV batteries)
Volume	42" long x 18" wide x 22" high (Overall geometry including control unit, etc. — The basic motor is a 16" dia x 24" cylinder which can be repackaged into a 9" dia x 12" cylinder)
Test Run Time	21.5 minutes
Battery Volt Reading at test completion	25.7 volts
Ambient Temp	84°F constant
Humidity	51%
Fuel Consumption	None (other than air)
Cooling	Conduction/ ½-pound (flow thru) air pressure
Magnetic Field Orientation	360° — all directions during motor operation
Lubrication	High temperature bearing grease (2 bearings)
Vibration	Negligible
Noise Level	No direct reading taken — without shielding, no louder than small kitchen appliance, eg fan, etc.
Start Mode	Simple push button — standard 12V starter motor
Operating Mode	Rheostat principle with switchable RPM range (500-1300-1950-2550-3360-4100 RPM's)
Physical Condition	Motor mounted on wheeled test stand — no external connections to stand.

### EMA-4 MOTOR BLOCK DIAGRAM

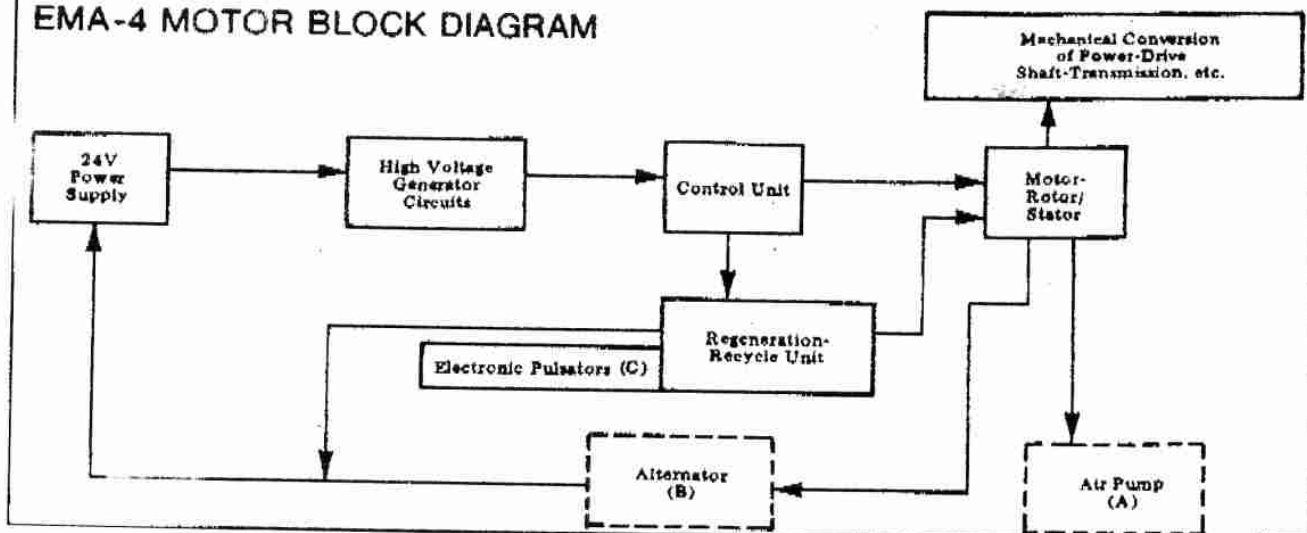

**BLOCK DIAGRAM OF THE EMA-4** shows how energy is transmitted from the four 6-volt batteries (power supply) to the various stages of the engine and returned. Both the air pump (A) and the alternator (B) are optional equipment. The air pump prevents Condensation around the drum and provides added assurance of air in some environments. The alternator is not needed for most applications, including use in vehicles, but may be desirable in heavy generator rigs. The electric pulsators (C), which are contained in the regeneration-recycle unit, are capable of pulsing at 200,000 times per minute, and the pulsation at 60- to 120 amperes is fed back to the batteries.