

Flame-thrower Rifle

Designed by Paul Rainwater

These plans are presented for educational and informational purposes only. This device is not a toy but an incredibly dangerous personal defense weapon. The builder assumes all responsibility for its construction and use thereof.

Several important details should be pointed out about this devices construction. The "propane fitting" on DWG 6 is the only part that requires machining. It is advised that a can of 'Coleman' brand propane be provided to the machinist that is going to do the work. The "propane fitting" is designed to screw onto 'Coleman' propane bottles. The propane is used as a pressure source for the gasoline tank. The dished endcaps for the gas tank are glued onto the PVC tank pipe using PVC glue. The regulator is a "Coilhose Pneumatics" 0-150 psi regulator with 1/4" ports. There are two ball valves used which are "B&K" brand ball valves with 1/4" ports. As for the ignition coil, almost any 12 volt coil will do.

Operation: Fill the gasoline tank 90% full and replace access plug. Ensure that the propane supply valve is **closed**. Screw a can of propane onto the "propane fitting" very quickly in order to minimize propane loss. Back off the regulator (counterclockwise). Slowly open the propane supply valve and monitor the pressure gauge on the regulator. It should read zero psig; if it doesn't, then back off the regulator until it reads zero. Once the propane supply valve is fully opened, slowly rotate the regulator (clockwise) until the gauge reads 40 psig. The gasoline tank is now pressurized. Check for leaks using a soap solution and fix any that are found. Once the gasoline tank is bled in, press the button in the forward handle and squeeze the handle lever. If all systems are working, a 40 ft flame should be expelled.

Refill procedure: Close off the propane valve and crack open the gasoline refill plug until a healthy leak is heard. Bleed the tank down to 0 psig and remove the gasoline refill plug. Fill tank with gasoline and replace plug. Open propane valve and repressurize tank.

Shutdown procedure: Close off the propane valve and crack open the gasoline refill plug until a healthy leak is heard. Bleed the tank down to 0 psig and back off the regulator.

Main Parts List

- (1) 4" sch40 PVC pipe 24" long
- (2) 4" sch40 PVC dished endcaps
- (1) 18" long 1/4" copper tubing
- (1) 36" long 3/8" copper tubing
- (2) 'B&K' brand 150 psi 1/4" ball valves
- (1) 'Coilhose Pneumatics' 0-150 psi 1/4" regulator
- (1) 36" long 1/2"x 1/8" stl. Flat stock
- (1) 36" long 1/2"x 1/4" stl. Flat stock
- (1) 36" long 1/2"x 1/8" alum. Flat stock
- (1) 36" long 1/2"x 1/4" alum. flat stock
- (1) 18" long 1"x 1/4" alum. Flat stock
- (1) 18" long 1/4" stl. Round stock
- (1) 1/4" brass pipe 5 1/2" long with threaded ends
- (1) 1/4" brass pipe 5" long with threaded ends
- (1) 12" long brass tubing .125" i.d. .155" o.d.
- (2) 1/4" brass female pipe endcaps
- (1) compression spring 2" long 3/4" diameter 10 lbs/inch spring constant
- (1) 3" long 1/2" stl. Round stock
- (1) 90° elbow 1/4" male pipe / 3/8" compression
- (1) straight 1/4" male pipe / 3/8" compression
- (2) 1/4" male pipe plugs
- (3) straight 1/4" male pipe / 1/4" compression
- (1) 2" long 1/4" pipe with threaded ends
- (1) 5" diameter hose clamp
- (1) Momentary pushbutton switch
- (1) 9volt double pole relay
- (1) 12volt ignition coil
- (1) .1 mf 200v capacitor
- (1) automotive ignition "condensor"
- (1) 9volt battery
- (1) 12volt camcorder battery
- (1) 12" long 3/4" stl. EMT electrical conduit
- (1) 12" long 2 1/2" nom. Thin walled pipe (chain link fence post)
- (1) 0-150 psig pressure gauge with 1/4" male port
- (2) 1/4-20 bolts x 1 1/2" long
- (3) 1/4-20 bolts x 1" long
- (3) 1/2-20 locknuts
- (4) 1/2-20 nuts
- (15) various screws

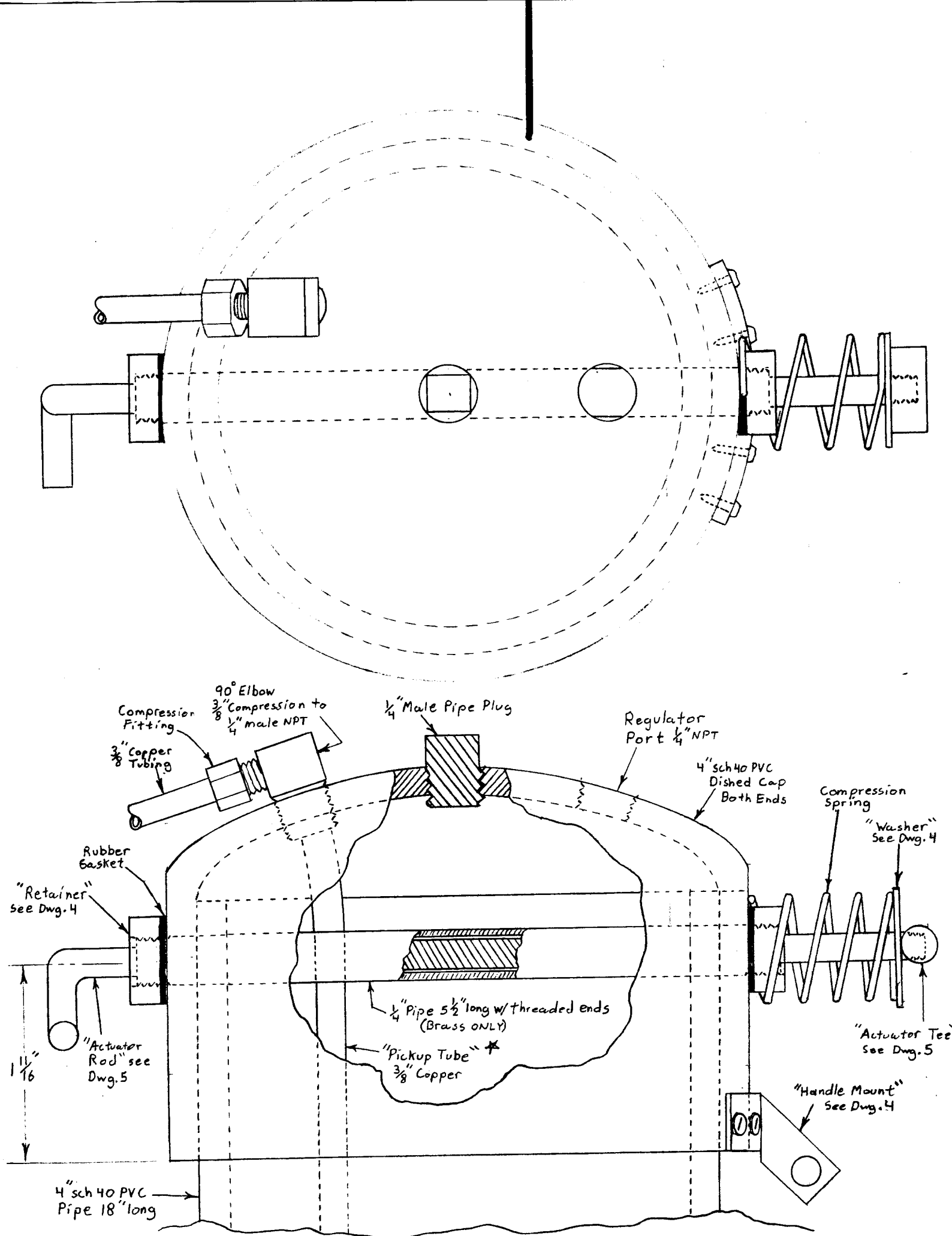

* Solder to 90° Elbow.
 Extend tubing to 1/4" off
 Bottom of tank.
 Flare end of tubing.

Gasoline Tank Detail
 Dwg 1 Full Scale

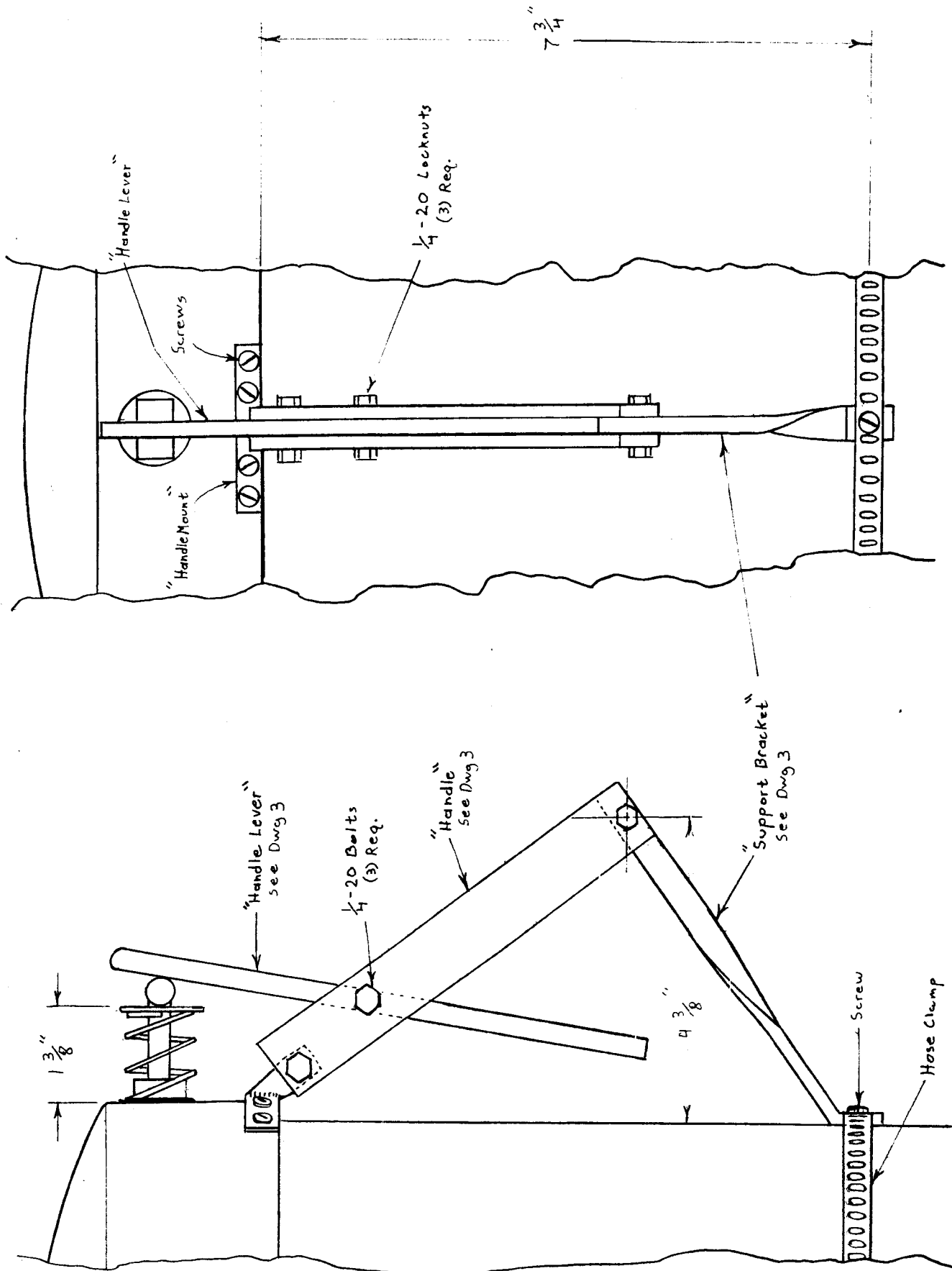

Actuation/Handle Assembly
 Dwg 2 Scale: NA

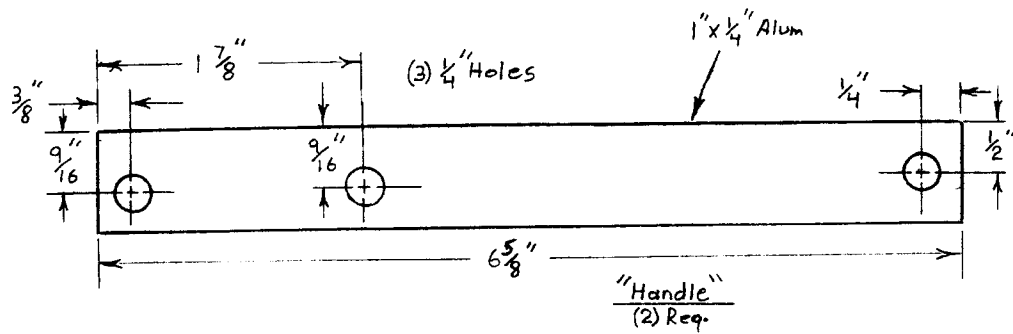
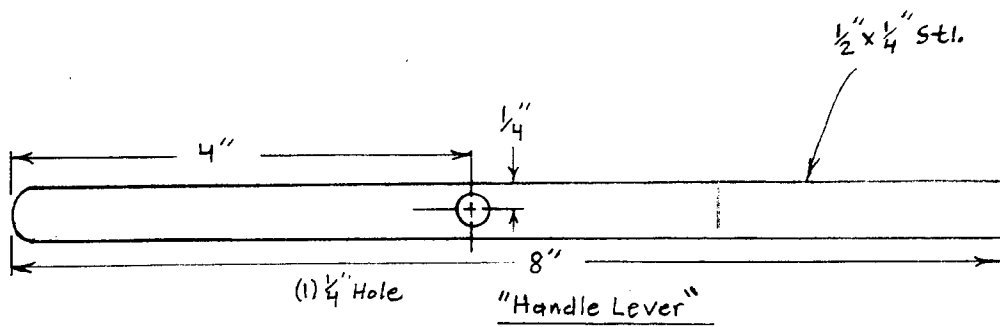
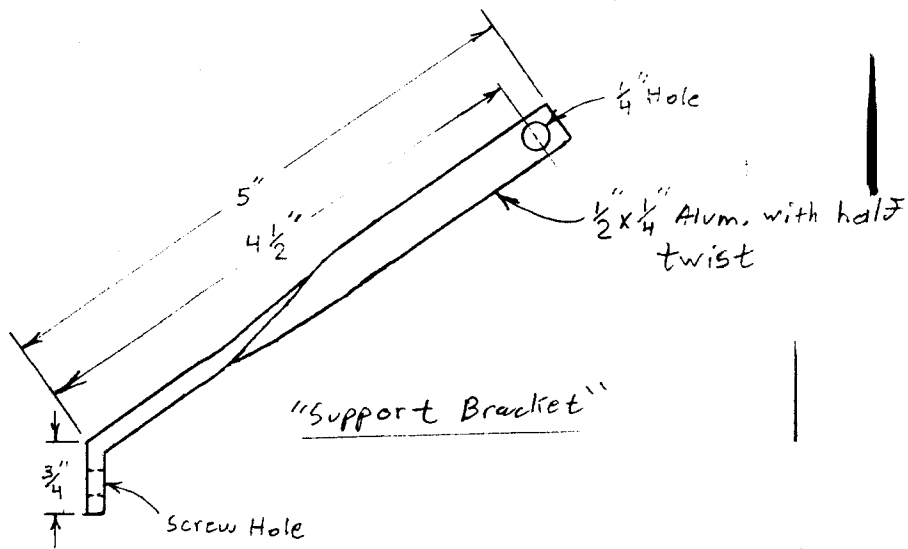

"Retainer" (2) req.

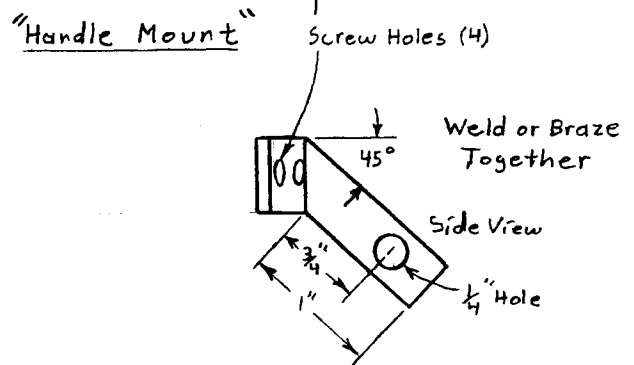
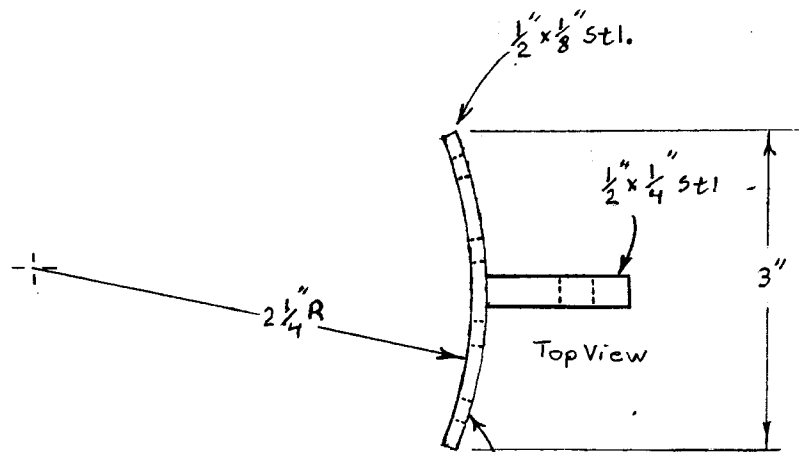
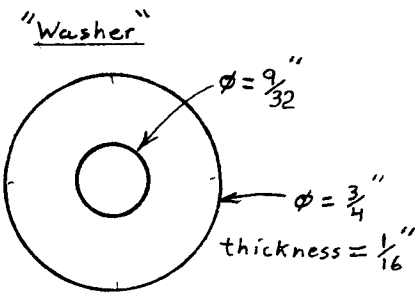
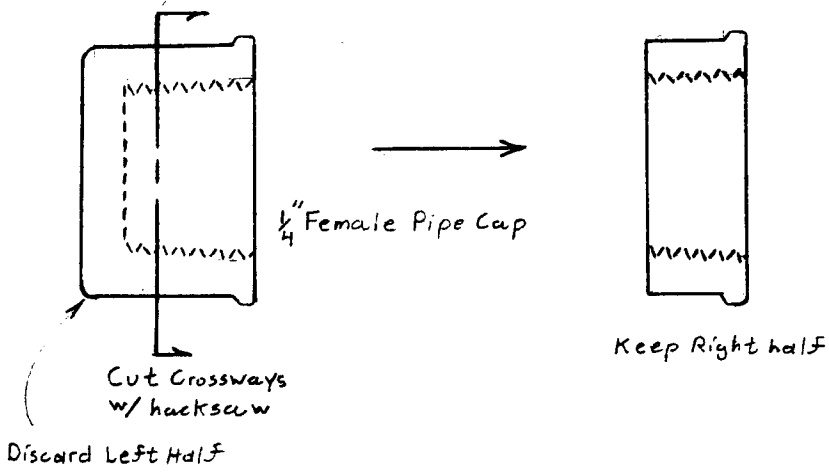

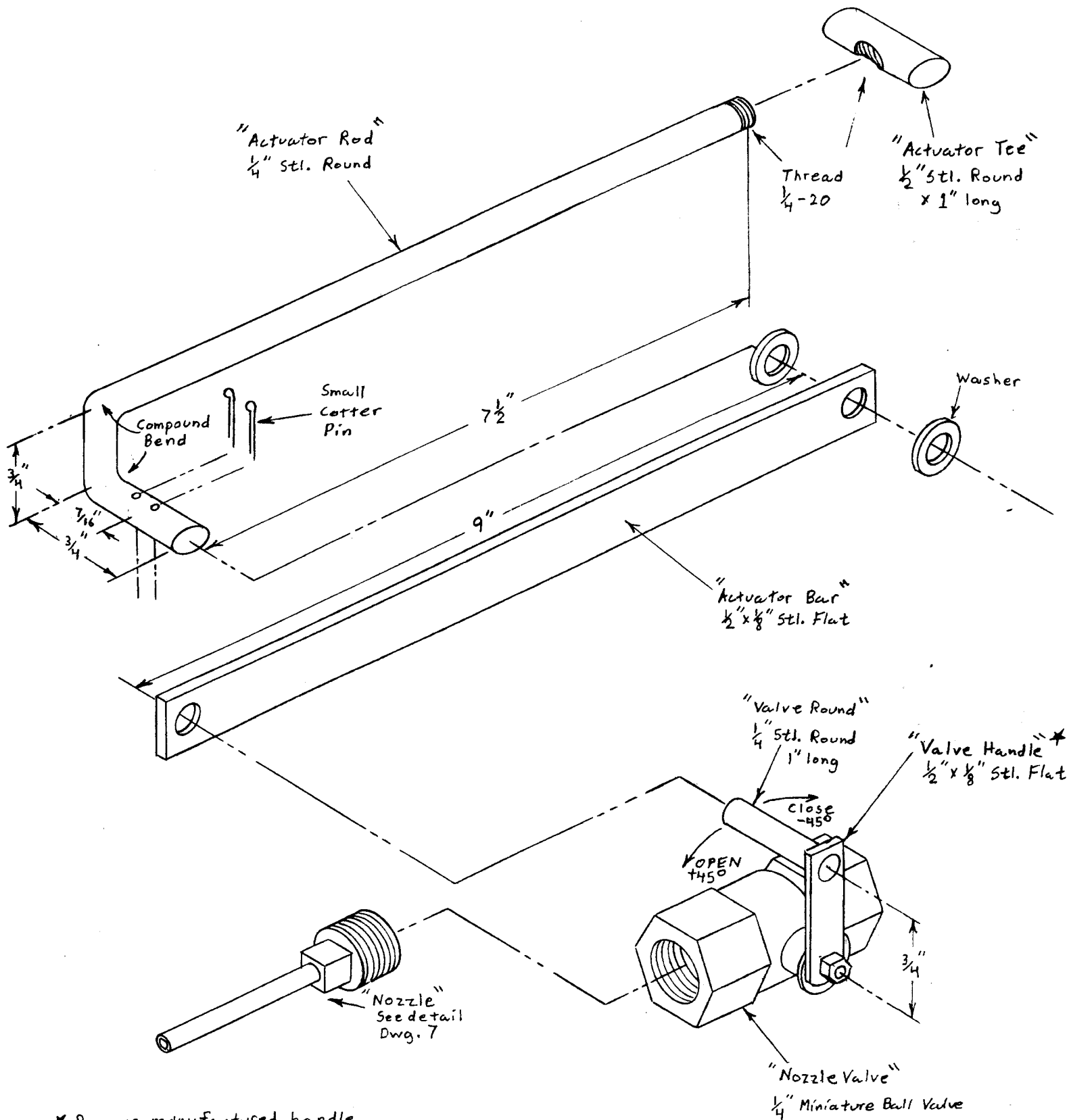

* Remove manufactured handle
 & replace with 1" long flat
 drilled $\frac{3}{4}$ " between centers
 Solder "Valve Round" to
 "Valve Handle"

Activation Valve Detail
 Dwg. 5 SCALE: NA

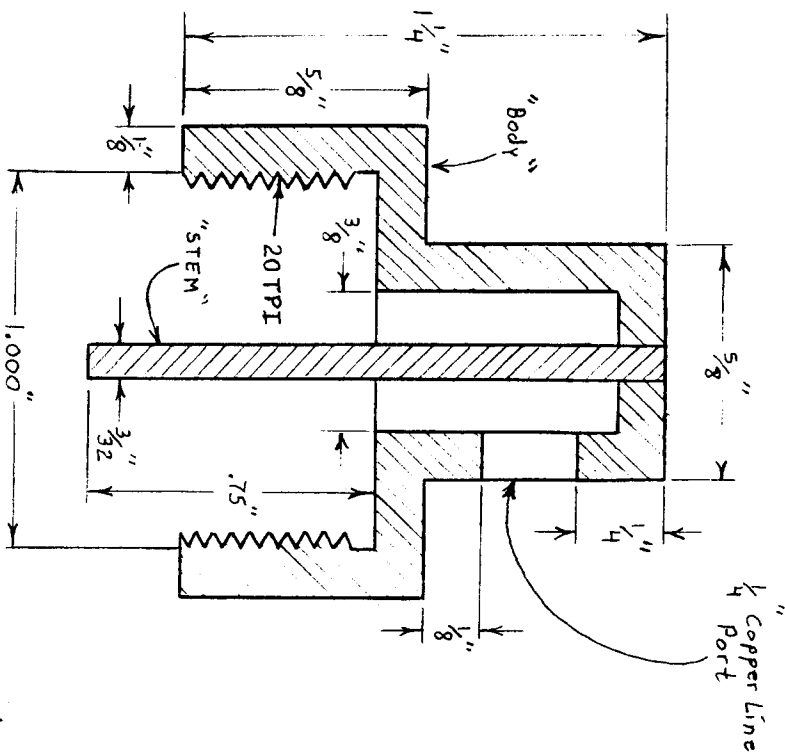

"Propane Fitting" 1/2 scale
Section view

Note: Shrink Fit "stem" to "Body"

"Body": Brass or Stl.
"stem": Stl. only
20 standard TPI

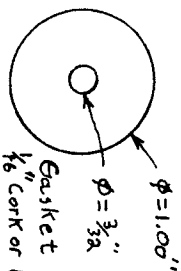

Gasket
1/8" Cork or Rubber
RTV to "Propane Fitting"

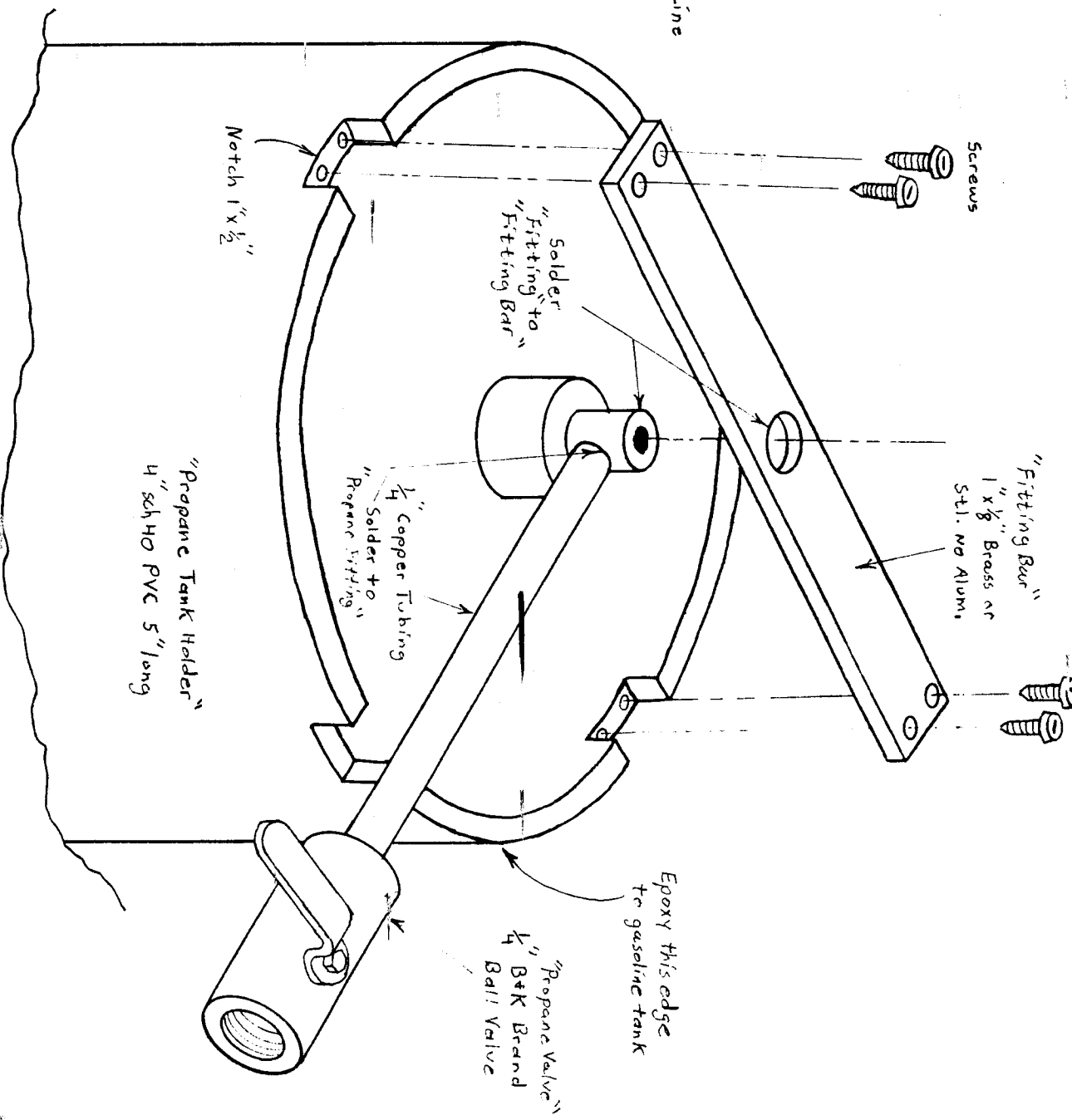

Insert Propane Tank
from this end + screw
into fitting

Note: "Propane Fitting" must
be concentric with
"Propane Tank Holder"

Propane Holder Assembly
Dwg. 6 Scale: NA

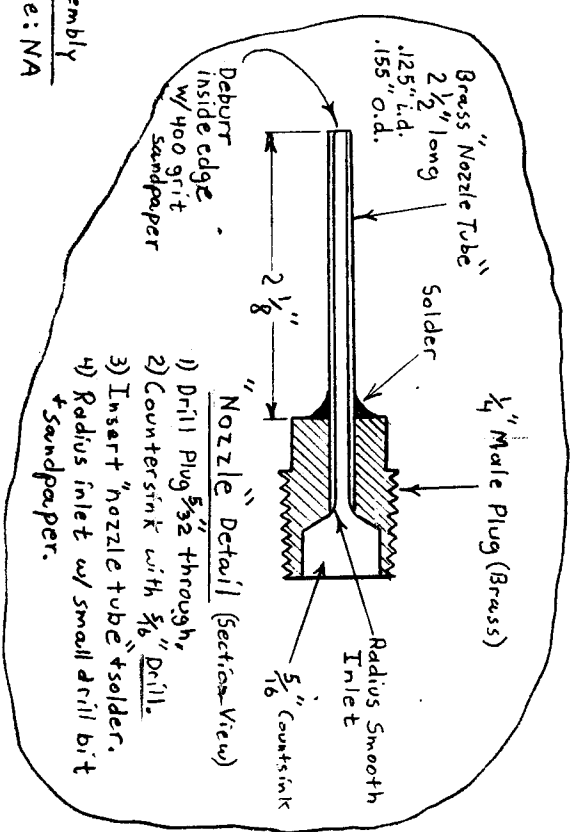
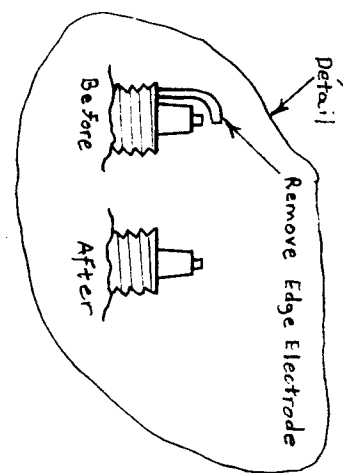
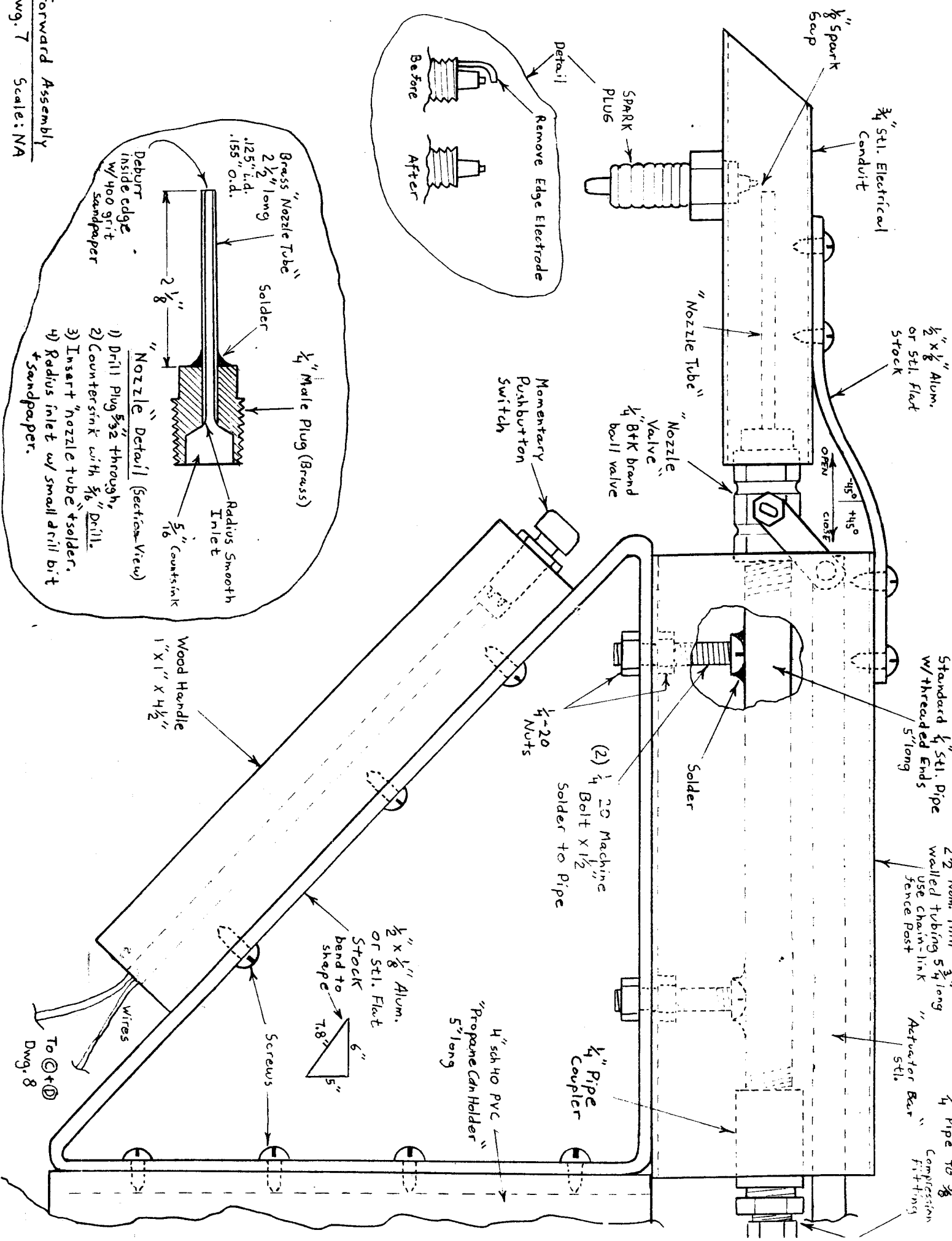

- 1) Drill Plug $\frac{5}{32}$ through,
- 2) Countersink with $\frac{3}{16}$ Drill.
- 3) Insert "nozzle tube" + solder.
- 4) Radius inlet w/ small drill bit + sandpaper.

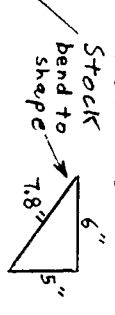

To \odot + \odot
 Dwg. 8

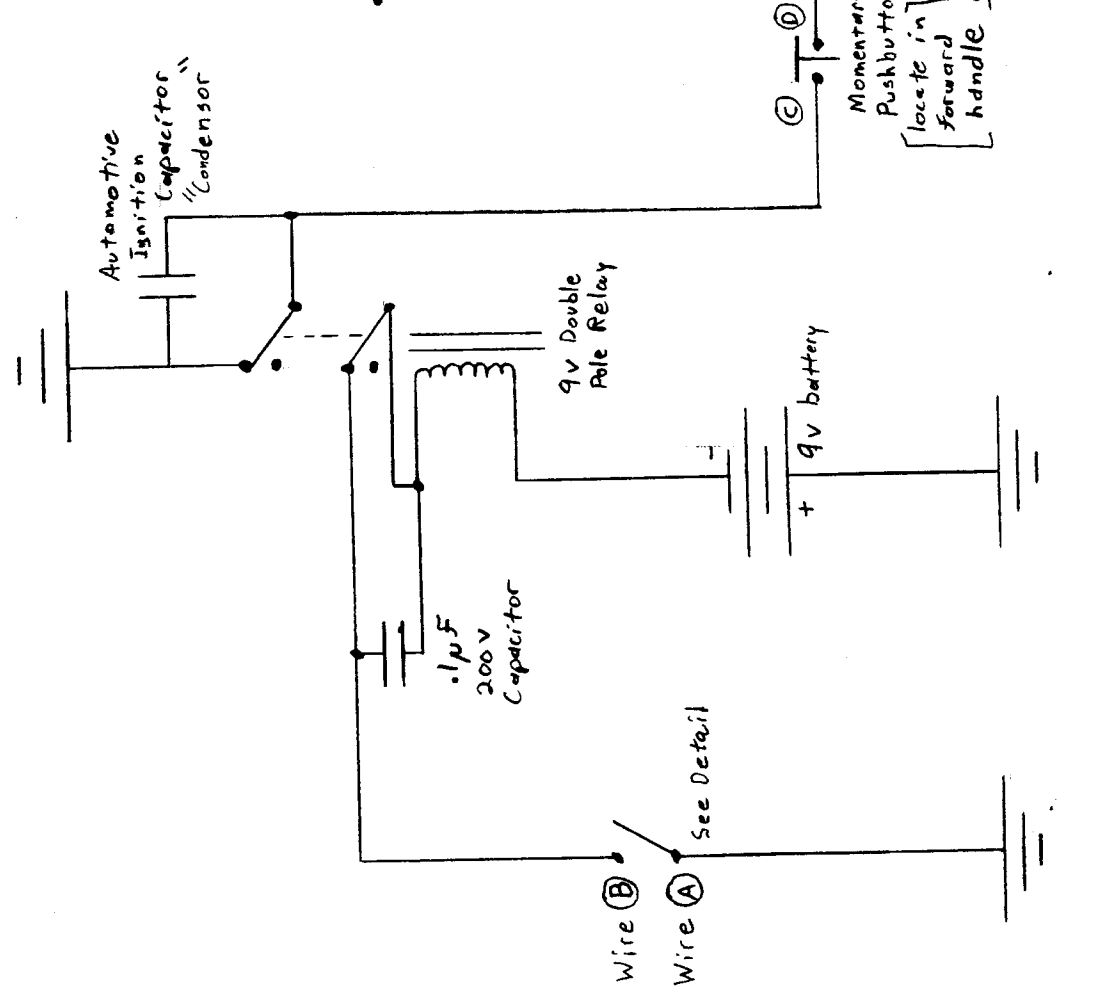
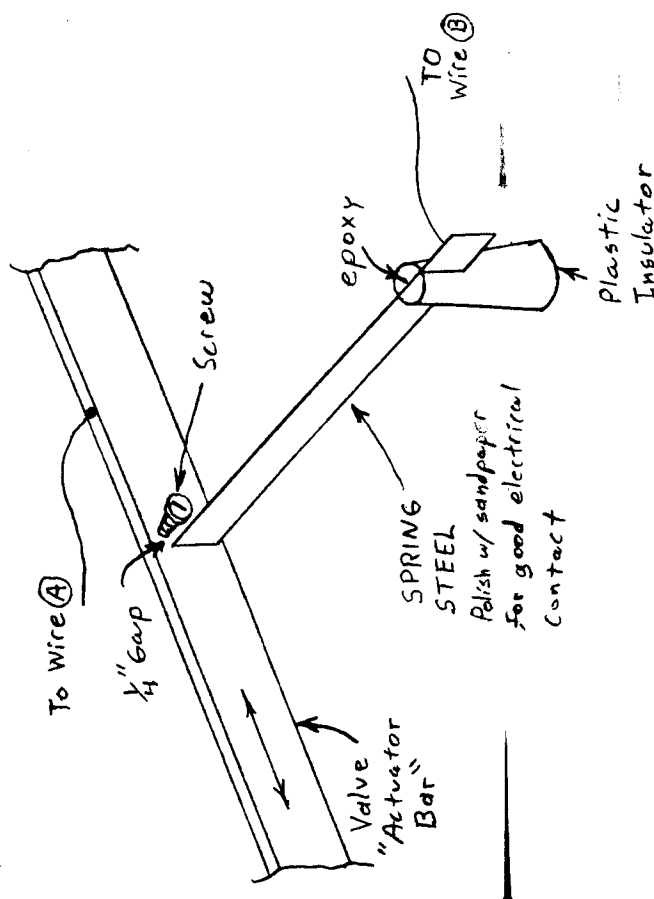

Electrical Schematic
 Dwg. 8 Scale: NA

