



# Precalculus Demystified

**RHONDA HUETTENMUELLER**

**McGRAW-HILL**

New York Chicago San Francisco Lisbon London  
Madrid Mexico City Milan New Delhi San Juan  
Seoul Singapore Sydney Toronto

Copyright © 2005 by The McGraw-Hill Companies, Inc. All rights reserved. Manufactured in the United States of America. Except as permitted under the United States Copyright Act of 1976, no part of this publication may be reproduced or distributed in any form or by any means, or stored in a database or retrieval system, without the prior written permission of the publisher.

0-07-146956-7

The material in this eBook also appears in the print version of this title: 0-07-143927-7.

All trademarks are trademarks of their respective owners. Rather than put a trademark symbol after every occurrence of a trademarked name, we use names in an editorial fashion only, and to the benefit of the trademark owner, with no intention of infringement of the trademark. Where such designations appear in this book, they have been printed with initial caps. McGraw-Hill eBooks are available at special quantity discounts to use as premiums and sales promotions, or for use in corporate training programs. For more information, please contact George Hoare, Special Sales, at [george\\_hoare@mcgraw-hill.com](mailto:george_hoare@mcgraw-hill.com) or (212) 904-4069.

## TERMS OF USE

This is a copyrighted work and The McGraw-Hill Companies, Inc. (“McGraw-Hill”) and its licensors reserve all rights in and to the work. Use of this work is subject to these terms. Except as permitted under the Copyright Act of 1976 and the right to store and retrieve one copy of the work, you may not decompile, disassemble, reverse engineer, reproduce, modify, create derivative works based upon, transmit, distribute, disseminate, sell, publish or sublicense the work or any part of it without McGraw-Hill’s prior consent. You may use the work for your own noncommercial and personal use; any other use of the work is strictly prohibited. Your right to use the work may be terminated if you fail to comply with these terms.

THE WORK IS PROVIDED “AS IS.” MCGRAW-HILL AND ITS LICENSORS MAKE NO GUARANTEES OR WARRANTIES AS TO THE ACCURACY, ADEQUACY OR COMPLETENESS OF OR RESULTS TO BE OBTAINED FROM USING THE WORK, INCLUDING ANY INFORMATION THAT CAN BE ACCESSED THROUGH THE WORK VIA HYPERLINK OR OTHERWISE, AND EXPRESSLY DISCLAIM ANY WARRANTY, EXPRESS OR IMPLIED, INCLUDING BUT NOT LIMITED TO IMPLIED WARRANTIES OF MERCHANTABILITY OR FITNESS FOR A PARTICULAR PURPOSE. McGraw-Hill and its licensors do not warrant or guarantee that the functions contained in the work will meet your requirements or that its operation will be uninterrupted or error free. Neither McGraw-Hill nor its licensors shall be liable to you or anyone else for any inaccuracy, error or omission, regardless of cause, in the work or for any damages resulting therefrom. McGraw-Hill has no responsibility for the content of any information accessed through the work. Under no circumstances shall McGraw-Hill and/or its licensors be liable for any indirect, incidental, special, punitive, consequential or similar damages that result from the use of or inability to use the work, even if any of them has been advised of the possibility of such damages. This limitation of liability shall apply to any claim or cause whatsoever whether such claim or cause arises in contract, tort or otherwise.

DOI: 10.1036/0071469567



<b>Preface</b>		<b>vii</b>
<b>CHAPTER 1</b>	<b>The Slope and Equation of a Line</b>	<b>1</b>
<b>CHAPTER 2</b>	<b>Introduction to Functions</b>	<b>24</b>
<b>CHAPTER 3</b>	<b>Functions and Their Graphs</b>	<b>42</b>
<b>CHAPTER 4</b>	<b>Combinations of Functions and Inverse Functions</b>	<b>64</b>
<b>CHAPTER 5</b>	<b>Translations and Special Functions</b>	<b>88</b>
<b>CHAPTER 6</b>	<b>Quadratic Functions</b>	<b>104</b>
<b>CHAPTER 7</b>	<b>Polynomial Functions</b>	<b>134</b>
<b>CHAPTER 8</b>	<b>Rational Functions</b>	<b>185</b>





## CONTENTS

<b>CHAPTER 9</b>	<b>Exponents and Logarithms</b>	<b>201</b>
<b>CHAPTER 10</b>	<b>Systems of Equations and Inequalities</b>	<b>262</b>
<b>CHAPTER 11</b>	<b>Matrices</b>	<b>303</b>
<b>CHAPTER 12</b>	<b>Conic Sections</b>	<b>330</b>
<b>CHAPTER 13</b>	<b>Trigonometry</b>	<b>364</b>
<b>CHAPTER 14</b>	<b>Sequences and Series</b>	<b>415</b>
<b>Appendix</b>		<b>439</b>
<b>Final Exam</b>		<b>450</b>
<b>Index</b>		<b>464</b>



# PREFACE

The goal of this book is to give you the skills and knowledge necessary to succeed in calculus. Much of the difficulty calculus students face is with algebra. They have to solve equations, find equations of lines, study graphs, solve word problems, and rewrite expressions—all of these require a solid background in algebra. You will get experience with all this and more in this book. Not only will you learn about the basic functions in this book, you also will strengthen your algebra skills because all of the examples and most of the solutions are given with a lot of detail. Enough steps are given in the problems to make the reasoning easy to follow.

The basic functions covered in this book are linear, polynomial, and rational functions, as well as exponential, logarithmic, and trigonometric functions. Because understanding the slope of a line is crucial to making sense of calculus, the interpretation of a line's slope is given extra attention. Other calculus topics introduced in this book are Newton's Quotient, the average rate of change, increasing/decreasing intervals of a function, and optimizing functions. Your experience with these ideas will help you when you learn calculus.

Concepts are presented in clear, simple language, followed by detailed examples. To make sure you understand the material, each section ends with a set of practice problems. Each chapter ends with a multiple-choice test, and there is a final exam at the end of the book. You will get the most from this book if you work steadily from the beginning to the end. Because much of the material is sequential, you should review the ideas in the previous section. Study for each end-of-chapter test as if it really were a test, and take it without looking at examples and without using notes. This will let you know what you have learned and where, if anywhere, you need to spend more time.

Good luck.



## CHAPTER

1

# The Slope and Equation of a Line

The slope of a line and the meaning of the slope are important in calculus. In fact, the slope formula is the basis for differential calculus. The slope of a line measures its tilt. The sign of the slope tells us if the line tilts up (if the slope is positive) or tilts down (if the slope is negative). The larger the number, the steeper the slope.

We can put any two points on the line,  $(x_1, y_1)$  and  $(x_2, y_2)$ , in the slope formula to find the slope of the line.

$$m = \frac{y_2 - y_1}{x_2 - x_1}$$



1

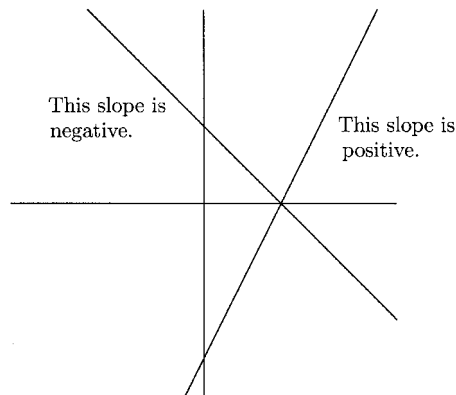

Fig. 1.1.

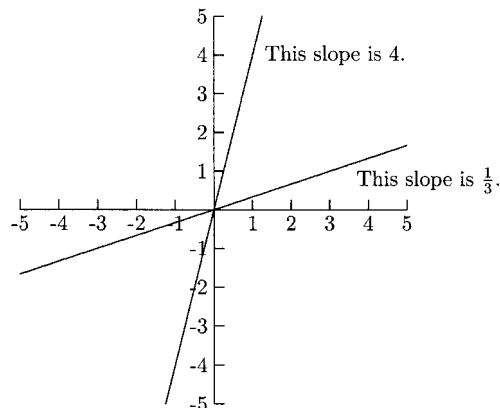

Fig. 1.2.

For example,  $(0, 3)$ ,  $(-2, 2)$ ,  $(6, 6)$ , and  $(-1, \frac{5}{2})$  are all points on the same line. We can pick any pair of points to compute the slope.

$$m = \frac{2 - 3}{-2 - 0} = \frac{-1}{-2} = \frac{1}{2} \qquad m = \frac{\frac{5}{2} - 2}{-1 - (-2)} = \frac{\frac{1}{2}}{1} = \frac{1}{2}$$

$$m = \frac{3 - 6}{0 - 6} = \frac{-3}{-6} = \frac{1}{2}$$

A slope of  $\frac{1}{2}$  means that if we increase the  $x$ -value by 2, then we need to increase the  $y$ -value by 1 to get another point on the line. For example, knowing that  $(0, 3)$  is on the line means that we know  $(0 + 2, 3 + 1) = (2, 4)$  is also on the line.

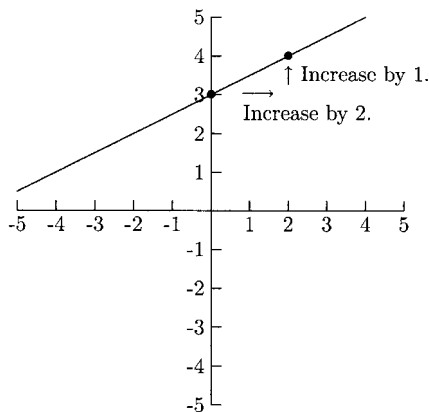

**Fig. 1.3.**

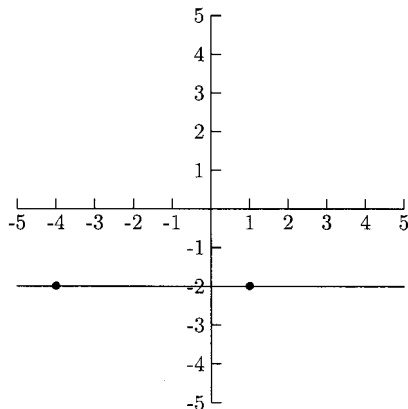

**Fig. 1.4.**

As we can see from Figure 1.4,  $(-4, -2)$  and  $(1, -2)$  are two points on a horizontal line. We will put these points in the slope formula.

$$m = \frac{-2 - (-2)}{1 - (-4)} = \frac{0}{5} = 0$$

The slope of every horizontal line is 0. The  $y$ -values on a horizontal line do not change but the  $x$ -values do.

What happens to the slope formula for a vertical line?



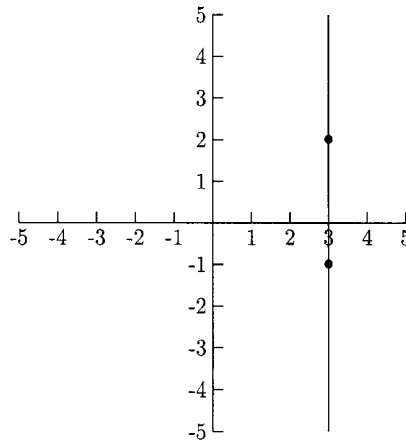

Fig. 1.5.

The points  $(3, 2)$  and  $(3, -1)$  are on the vertical line in Figure 1.5. Let's see what happens when we put them in the slope formula.

$$m = \frac{-1 - 2}{3 - 3} = \frac{-3}{0}$$

This is not a number so the slope of a vertical line does not exist (we also say that it is undefined). The  $x$ -values on a vertical line do not change but the  $y$ -values do.

Any line is the graph of a linear equation. The equation of a horizontal line is  $y = a$  (where  $a$  is the  $y$ -value of every point on the line). Some examples of horizontal lines are  $y = 4$ ,  $y = 1$ , and  $y = -5$ .

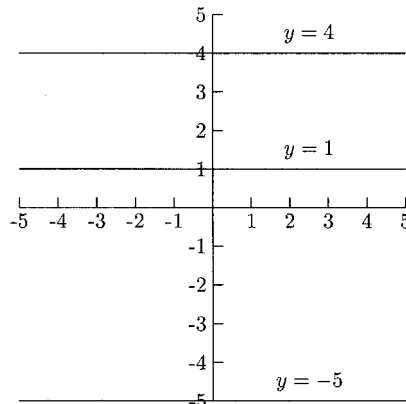

Fig. 1.6.

The equation of a vertical line is  $x = a$  (where  $a$  is the  $x$ -value of every point on the line). Some examples are  $x = -3$ ,  $x = 2$ , and  $x = 4$ .

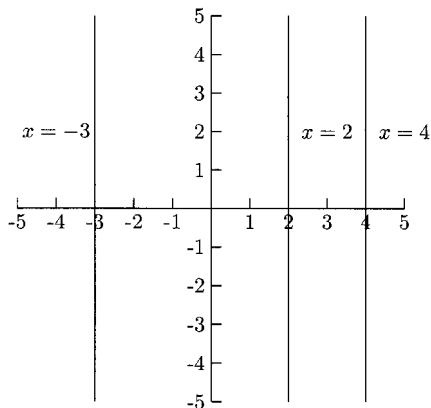

Fig. 1.7.

Other equations usually come in one of two forms:  $Ax + By = C$  and  $y = mx + b$ . We will usually use the form  $y = mx + b$  in this book. An equation in this form gives us two important pieces of information. The first is  $m$ , the slope. The second is  $b$ , the  $y$ -intercept (where the line crosses the  $y$ -axis). For this reason, this form is called the *slope-intercept* form. In the line  $y = \frac{2}{3}x + 4$ , the slope of the line is  $\frac{2}{3}$  and the  $y$ -intercept is  $(0, 4)$ , or simply, 4.

We can find an equation of a line by knowing its slope and any point on the line. There are two common methods for finding this equation. One is to put  $m$ ,  $x$ , and  $y$  ( $x$  and  $y$  are the coordinates of the point we know) in  $y = mx + b$  and use algebra to find  $b$ . The other is to put these same numbers in the *point-slope* form of the line,  $y - y_1 = m(x - x_1)$ . We will use both methods in the next example.

## EXAMPLES

- Find an equation of the line with slope  $-\frac{3}{4}$  containing the point  $(8, -2)$ .  
We will let  $m = -\frac{3}{4}$ ,  $x = 8$ , and  $y = -2$  in  $y = mx + b$  to find  $b$ .

$$-2 = -\frac{3}{4}(8) + b$$

$$4 = b$$

The line is  $y = -\frac{3}{4}x + 4$ .



## CHAPTER 1 The Slope and Equation

Now we will let  $m = -\frac{3}{4}$ ,  $x_1 = 8$  and  $y_1 = -2$  in  $y - y_1 = m(x - x_1)$ .

$$y - (-2) = -\frac{3}{4}(x - 8)$$

$$y + 2 = -\frac{3}{4}x + 6$$

$$y = -\frac{3}{4}x + 4$$

- Find an equation of the line with slope 4, containing the point  $(0, 3)$ .  
We know the slope is 4 and we know the  $y$ -intercept is 3 (because  $(0, 3)$  is on the line), so we can write the equation without having to do any work:  
 $y = 4x + 3$ .
- Find an equation of the horizontal line that contains the point  $(5, -6)$ .  
Because the  $y$ -values are the same on a horizontal line, we know that this equation is  $y = -6$ . We can still find the equation algebraically using the fact that  $m = 0$ ,  $x = 5$  and  $y = -6$ . Then  $y = mx + b$  becomes  $-6 = 0(5) + b$ . From here we can see that  $b = -6$ , so  $y = 0x - 6$ , or simply,  $y = -6$ .
- Find an equation of the vertical line containing the point  $(10, -1)$ .  
Because the  $x$ -values are the same on a vertical line, we know that the equation is  $x = 10$ . We cannot find this equation algebraically because  $m$  does not exist.

We can find an equation of a line if we know any two points on the line. First we need to use the slope formula to find  $m$ . Then we will pick one of the points to put into  $y = mx + b$ .

### EXAMPLES

Find an equation of the line containing the given points.

- $(-2, 3)$  and  $(10, 15)$

$$m = \frac{15 - 3}{10 - (-2)} = 1$$

We will use  $x = -2$  and  $y = 3$  in  $y = mx + b$  to find  $b$ .

$$3 = 1(-2) + b$$

$$5 = b$$

The equation is  $y = 1x + 5$ , or simply  $y = x + 5$ .

- $(\frac{1}{2}, -1)$  and  $(4, 3)$

$$m = \frac{3 - (-1)}{4 - \frac{1}{2}} = \frac{4}{\frac{7}{2}} = 4 \div \frac{7}{2} = 4 \cdot \frac{2}{7} = \frac{8}{7}$$

Using  $x = 4$  and  $y = 3$  in  $y = mx + b$ , we have

$$3 = \frac{8}{7}(4) + b$$

$$-\frac{11}{7} = b.$$

The equation is  $y = \frac{8}{7}x - \frac{11}{7}$ .

- $(0, 1)$  and  $(12, 1)$

The  $y$ -values are the same, making this a horizontal line. The equation is  $y = 1$ .

If a graph is clear enough, we can find two points on the line or even its slope. If fact, if the slope and  $y$ -intercept are easy enough to see on the graph, we know right away what the equation is.

## EXAMPLES

- 

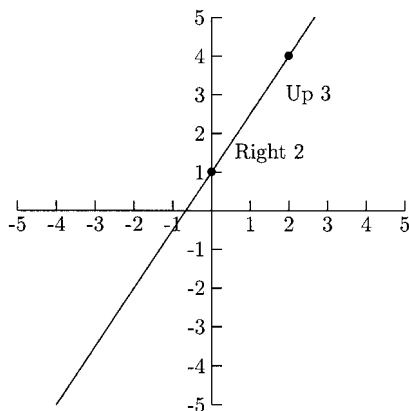

**Fig. 1.8.**

The line in Figure 1.8 crosses the  $y$ -axis at 1, so  $b = 1$ . From this point, we can go right 2 and up 3 to reach the point  $(2, 4)$  on the line. “Right 2” means that the denominator of the slope is 2. “Up 3” means that the numerator of the slope is 3. The slope is  $\frac{3}{2}$ , so the equation of the line is  $y = \frac{3}{2}x + 1$ .

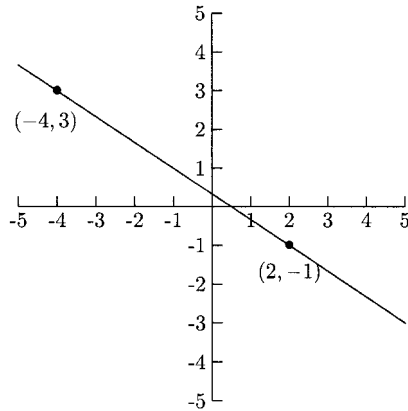

Fig. 1.9.

The  $y$ -intercept is not easy to determine, but we do have two points. We can either find the slope by using the slope formula, or visually (as we did above). We can find the slope visually by asking how we can go from  $(-4, 3)$  to  $(2, -1)$ : Down 4 (making the numerator of the slope  $-4$ ) and right 6 (making the denominator 6). If we use the slope formula, we have

$$m = \frac{-1 - 3}{2 - (-4)} = \frac{-4}{6} = -\frac{2}{3}.$$

Using  $x = 2$  and  $y = -1$  in  $y = mx + b$ , we have  $-1 = -\frac{2}{3}(2) + b$ . From this, we have  $b = \frac{1}{3}$ . The equation is  $y = -\frac{2}{3}x + \frac{1}{3}$ .

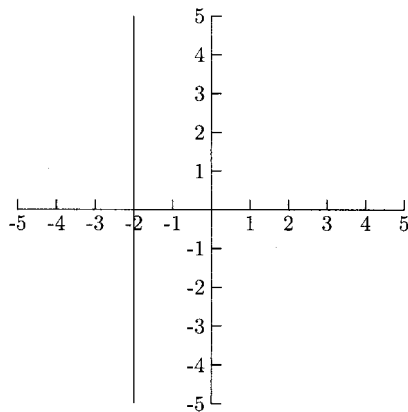

Fig. 1.10.

The line in Figure 1.10 is vertical, so it has the form  $x = a$ . All of the  $x$ -values are  $-2$ , so the equation is  $x = -2$ .

When an equation for a line is in the form  $Ax + By = C$ , we can find the slope by solving the equation for  $y$ . This will put the equation in the form  $y = mx + b$ .

## EXAMPLE

- Find the slope of the line  $6x - 2y = 3$ .

$$6x - 2y = 3$$

$$-2y = -6x + 3$$

$$y = 3x - \frac{3}{2}$$

The slope is 3 (or  $\frac{3}{1}$ ).

Two lines are parallel if their slopes are equal (or if both lines are vertical).

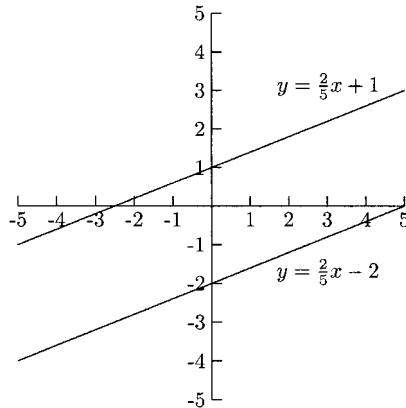

**Fig. 1.11.**

Two lines are perpendicular if their slopes are *negative reciprocals* of each other (or if one line is horizontal and the other is vertical). Two numbers are negative reciprocals of each other if one is positive and the other is negative and inverting one gets the other (if we ignore the sign).

## EXAMPLES

- $\frac{5}{6}$  and  $-\frac{6}{5}$  are negative reciprocals
- $-\frac{3}{4}$  and  $\frac{4}{3}$  are negative reciprocals

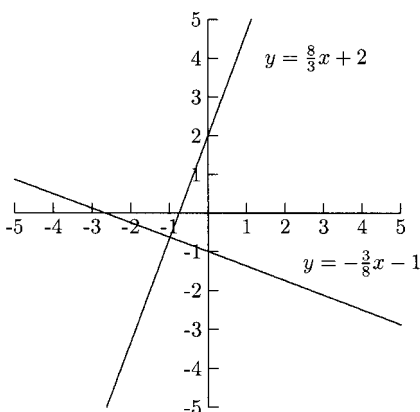

Fig. 1.12.

- $-2$  and  $\frac{1}{2}$  are negative reciprocals
- $1$  and  $-1$  are negative reciprocals

We can decide whether two lines are parallel or perpendicular or neither by putting them in the form  $y = mx + b$  and comparing their slopes.

## EXAMPLES

Determine whether the lines are parallel or perpendicular or neither.

- $4x - 3y = -15$  and  $4x - 3y = 6$

$$4x - 3y = -15$$

$$-3y = -4x - 15$$

$$y = \frac{4}{3}x + 5$$

$$4x - 3y = 6$$

$$-3y = -4x + 6$$

$$y = \frac{4}{3}x - 2$$

The lines have the same slope, so they are parallel.

- $3x - 5y = 20$  and  $5x - 3y = -15$

$$3x - 5y = 20$$

$$-5y = -3x + 20$$

$$y = \frac{3}{5}x - 4$$

$$5x - 3y = -15$$

$$-3y = -5x - 15$$

$$y = \frac{5}{3}x + 5$$

The slopes are reciprocals of each other but not *negative* reciprocals, so they are not perpendicular. They are not parallel, either.

- $x - y = 2$  and  $x + y = -8$

$$x - y = 2$$

$$x + y = -8$$

$$y = x - 2$$

$$y = -x - 8$$

The slope of the first line is 1 and the second is  $-1$ . Because 1 and  $-1$  are negative reciprocals, these lines are perpendicular.

- $y = 10$  and  $x = 3$   
The line  $y = 10$  is horizontal, and the line  $x = 3$  is vertical. They are perpendicular.

Sometimes we need to find an equation of a line when we know only a point on the line and an equation of another line that is either parallel or perpendicular to it. We need to find the slope of the line whose equation we have and use this to find the equation of the line we are looking for.

## EXAMPLES

- Find an equation of the line containing the point  $(-4, 5)$  that is parallel to the line  $y = 2x + 1$ .  
The slope of  $y = 2x + 1$  is 2. This is the same as the line we want, so we will let  $x = -4$ ,  $y = 5$ , and  $m = 2$  in  $y = mx + b$ . We get  $5 = 2(-4) + b$ , so  $b = 13$ . The equation of the line we want is  $y = 2x + 13$ .
- Find an equation of the line with  $x$ -intercept 4 that is perpendicular to  $x - 3y = 12$ .  
The  $x$ -intercept is 4 means that the point  $(4, 0)$  is on the line. The slope of the line we want will be the negative reciprocal of the slope of the line  $x - 3y = 12$ . We will find the slope of  $x - 3y = 12$  by solving for  $y$ .

$$x - 3y = 12$$

$$y = \frac{1}{3}x - 4$$

The slope we want is  $-3$ , which is the negative reciprocal of  $\frac{1}{3}$ . When we let  $x = 4$ ,  $y = 0$ , and  $m = -3$  in  $y = mx + b$ , we have  $0 = -3(4) + b$ , which gives us  $b = 12$ . The line is  $y = -3x + 12$ .

- Find an equation of the line containing the point  $(3, -8)$ , perpendicular to the line  $y = 9$ .  
The line  $y = 9$  is horizontal, so the line we want is vertical. The vertical line passing through  $(3, -8)$  is  $x = 3$ .



## PRACTICE

When asked to find an equation for a line, put your answer in the form  $y = mx + b$  unless the line is horizontal ( $y = a$ ) or vertical ( $x = a$ ).

1. Find the slope of the line containing the points  $(4, 12)$  and  $(-6, 1)$ .
2. Find the slope of the line with  $x$ -intercept 5 and  $y$ -intercept  $-3$ .
3. Find an equation of the line containing the point  $(-10, 4)$  with slope  $-\frac{2}{5}$ .
4. Find an equation of the line with  $y$ -intercept  $-5$  and slope 2.
5. Find an equation of the line in Figure 1.13.

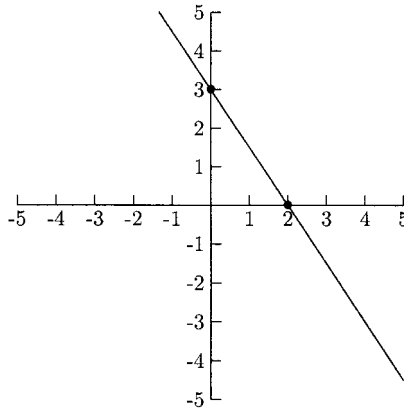

Fig. 1.13.

6. Find an equation of the line containing the points  $(\frac{3}{4}, 1)$  and  $(-2, -1)$ .
7. Determine whether the lines  $3x - 7y = 28$  and  $7x + 3y = 3$  are parallel or perpendicular or neither.
8. Find an equation of the line containing  $(2, 3)$  and perpendicular to the line  $x - y = 5$ .
9. Find an equation of the line parallel to the line  $x = 6$  containing the point  $(-3, 2)$ .
10. Determine whether the lines  $2x - 3y = 1$  and  $-4x + 6y = 5$  are parallel or perpendicular or neither.

**SOLUTIONS**

$$1. m = \frac{1 - 12}{-6 - 4} = \frac{-11}{-10} = \frac{11}{10}$$

2. The  $x$ -intercept is 5 and the  $y$ -intercept is  $-3$  mean that the points  $(5, 0)$  and  $(0, -3)$  are on the line.

$$m = \frac{-3 - 0}{0 - 5} = \frac{-3}{-5} = \frac{3}{5}$$

3. Put  $x = -10$ ,  $y = 4$ , and  $m = -\frac{2}{5}$  in  $y = mx + b$  to find  $b$ .

$$4 = -\frac{2}{5}(-10) + b$$

$$0 = b$$

The equation is  $y = -\frac{2}{5}x + 0$ , or simply  $y = -\frac{2}{5}x$ .

4.  $m = 2$ ,  $b = -5$ , so the line is  $y = 2x - 5$ .
5. From the graph, we can see that the  $y$ -intercept is 3. We can use the indicated points  $(0, 3)$  and  $(2, 0)$  to find the slope in two ways. One way is to put these numbers in the slope formula.

$$m = \frac{0 - 3}{2 - 0} = -\frac{3}{2}$$

The other way is to move from  $(0, 3)$  to  $(2, 0)$  by going down 3 (so the numerator of the slope is  $-3$ ) and right 2 (so the denominator is 2). Either way, we have the slope  $-\frac{3}{2}$ . Because the  $y$ -intercept is 3, the equation is  $y = -\frac{3}{2}x + 3$ .

$$6. m = \frac{-1 - 1}{-2 - \frac{3}{4}} = \frac{-2}{-\frac{11}{4}} = -2 \div -\frac{11}{4} = -2 \cdot -\frac{4}{11} = \frac{8}{11}$$

We will use  $x = -2$  and  $y = -1$  in  $y = mx + b$ .

$$-1 = \frac{8}{11}(-2) + b$$

$$\frac{5}{11} = b$$

The equation is  $y = \frac{8}{11}x + \frac{5}{11}$ .

7. We will solve for  $y$  in each equation so that we can compare their slopes.

$$3x - 7y = 28$$

$$y = \frac{3}{7}x - 4$$

$$7x + 3y = 3$$

$$y = -\frac{7}{3}x + 1$$

The slopes are negative reciprocals of each other, so these lines are perpendicular.

8. Once we have found the slope for the line  $x - y = 5$ , we will use its negative reciprocal as the slope of the line we want.

$$x - y = 5$$

$$y = x - 5$$

The slope of this line is 1. The negative reciprocal of 1 is  $-1$ . We will use  $x = 2$ ,  $y = 3$ , and  $m = -1$  in  $y = mx + b$ .

$$3 = -1(2) + b$$

$$5 = b$$

The equation is  $y = -1x + 5$ , or simply  $y = -x + 5$ .

9. The line  $x = 6$  is vertical, so the line we want is also vertical. The vertical line that goes through  $(-3, 2)$ , is  $x = -3$ .
10. We will solve for  $y$  in each equation and compare their slopes.

$$2x - 3y = 1$$

$$y = \frac{2}{3}x - \frac{1}{3}$$

$$-4x + 6y = 5$$

$$y = \frac{2}{3}x + \frac{5}{6}$$

The slopes are the same, so these lines are parallel.

## Applications of Lines and Slopes

We can use the slope of a line to decide whether points in the plane form certain shapes. Here, we will use the slope to decide whether or not three points form a right triangle and whether or not four points form a parallelogram. After we plot the points, we can decide which points to put into the slope formula.

## EXAMPLES

- Show that  $(-1, 2)$ ,  $(4, -3)$ , and  $(5, 0)$  are the vertices of a right triangle.

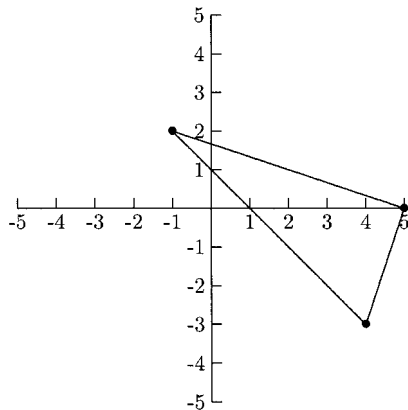

**Fig. 1.14.**

From the graph in Figure 1.14, we can see that the line segment between  $(5, 0)$  and  $(-1, 2)$  should be perpendicular to the line segment between  $(5, 0)$  and  $(4, -3)$ . Once we have found the slopes of these line segments, we will see that they are negative reciprocals.

$$m = \frac{2 - 0}{-1 - 5} = -\frac{1}{3}$$

$$m = \frac{-3 - 0}{4 - 5} = 3$$

- Show that  $(-3, 1)$ ,  $(3, -5)$ ,  $(4, -1)$ , and  $(-2, 5)$  are the vertices of a parallelogram.

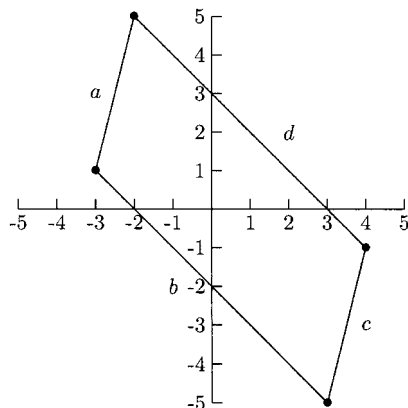

**Fig. 1.15.**

From the graph in Figure 1.15, we see that we need to show that line segments  $a$  and  $c$  are parallel and that line segments  $b$  and  $d$  are parallel.

$$\text{The slope for segment } a \text{ is } m = \frac{5 - 1}{-2 - (-3)} = 4,$$

$$\text{and the slope for segment } c \text{ is } m = \frac{-1 - (-5)}{4 - 3} = 4.$$

$$\text{The slope for segment } b \text{ is } m = \frac{-5 - 1}{3 - (-3)} = -1,$$

$$\text{and the slope for segment } d \text{ is } m = \frac{-1 - 5}{4 - (-2)} = -1.$$

There are many applications of linear equations to business and science. Suppose the property tax rate for a school district is \$1.50 per \$100 valuation. This is a linear relationship between the value of the property and the amount of tax on the property. The slope of the line in this relationship is

$$\frac{\text{Tax change}}{\text{Value change}} = \frac{\$1.50}{\$100}.$$

As the value of property increases by \$100, the tax increases by \$1.50. Two variables are linearly related if a fixed increase of one variable causes a fixed increase or decrease in the other variable. These changes are proportional. For example, if a property increases in value by \$50, then its tax would increase by \$0.75.

We can find an equation (also called a model) that describes the relationship between two variables if we are given two points or one point and the slope. As in most word problems, we will need to find the information in the statement of the problem, it is seldom spelled out for us. One of the first things we need to do is to decide which quantity will be represented by  $x$  and which by  $y$ . Sometimes it does not matter. In the problems that follow, it will matter. If we are instructed to “give variable 1 in terms of variable 2,” then variable 1 will be  $y$  and variable 2 will be  $x$ . This is because in the equation  $y = mx + b$ ,  $y$  is given in terms of  $x$ . For example, if we are asked to give the property tax in terms of property value, then  $y$  would represent the property tax and  $x$  would represent the property value.

## EXAMPLES

- A family paid \$52.50 for water in January when they used 15,000 gallons and \$77.50 in May when they used 25,000 gallons. Find an equation that gives the amount of the water bill in terms of the number of gallons of water used.

Because we need to find the cost in terms of water used, we will let  $y$  represent the cost and  $x$ , the amount of water used. Our ordered pairs will be (water, cost): (15,000, 52.50) and (25,000, 77.50). Now we can compute the slope.

$$m = \frac{77.50 - 52.50}{25,000 - 15,000} = 0.0025$$

We will use  $x = 15,000$ ,  $y = 52.50$ , and  $m = 0.0025$  in  $y = mx + b$  to find  $b$ .

$$52.50 = 0.0025(15,000) + b$$

$$15 = b$$

The equation is  $y = 0.0025x + 15$ . With this equation, the family can predict its water bill by putting the amount of water used in the equation. For example, 32,000 gallons would cost  $0.0025(32,000) + 15 = \$95$ .

- A bakery sells a special bread. It costs \$6000 to produce 10,000 loaves of bread per day and \$5900 to produce 9500 loaves. Find an equation that gives the daily costs in terms of the number of loaves of bread produced.

Because we want the cost in terms of the number of loaves produced, we will let  $y$  represent the daily cost and  $x$ , the number of loaves produced. Our points will be of the form (number of loaves, daily cost): (10,000, 6000) and (9500, 5900).

$$m = \frac{5900 - 6000}{9500 - 10,000} = \frac{1}{5}$$

We will use  $x = 10,000$ ,  $y = 6000$ , and  $m = \frac{1}{5}$  in  $y = mx + b$ .

$$6000 = \frac{1}{5}(10,000) + b$$

$$4000 = b$$

The equation is  $y = \frac{1}{5}x + 4000$ .

The slope, and sometimes the  $y$ -intercept, have important meanings in applied problems. In the first example, the household water bill was computed using  $y = 0.0025x + 15$ . The slope means that each gallon costs \$0.0025 (or 0.25 cents). As the number of gallons increases by 1, the cost increases by \$0.0025. The  $y$ -intercept is the cost when 0 gallons are used. This additional monthly charge is \$15. The slope in the bakery problem means that five loaves of bread costs \$1 to

produce (or each loaf costs \$0.20). The  $y$ -intercept tells us the bakery's daily fixed costs are \$4000. Fixed costs are costs that the bakery must pay regardless of the number of loaves produced. Fixed costs might include rent, equipment payments, insurance, taxes, etc.

In the following examples, information about the slope will be given and a point will be given or implied.

- The dosage of medication given to an adult cow is 500 mg plus 9 mg per pound. Find an equation that gives the amount of medication (in mg) per pound of weight.

We will use 500 mg as the  $y$ -intercept. The slope is

$$\frac{\text{increase in medication}}{\text{increase in weight}} = \frac{9}{1}$$

The equation is  $y = 9x + 500$ , where  $x$  is in pounds and  $y$  is in milligrams.

- At the surface of the ocean, a certain object has 1500 pounds of pressure on it. For every foot below the surface, the pressure on the object increases about 43 pounds. Find an equation that gives the pressure (in pounds) on the object in terms of its depth (in feet) in the ocean.

At 0 feet, the pressure on the object is 1500 lbs, so the  $y$ -intercept is 1500. The slope is

$$\frac{\text{increase in pressure}}{\text{increase in depth}} = \frac{43}{1} = 43.$$

This makes the equation  $y = 43x + 1500$ , where  $x$  is the depth in feet and  $y$  is the pressure in pounds.

- A pancake mix requires  $\frac{3}{4}$  cup of water for each cup of mix. Find an equation that gives the amount of water needed in terms of the amount of pancake mix. Although no point is directly given, we can assume that  $(0, 0)$  is a point on the line because when there is no mix, no water is needed. The slope is

$$\frac{\text{increase in water}}{\text{increase in mix}} = \frac{3/4}{1} = \frac{3}{4}.$$

The equation is  $y = \frac{3}{4}x + 0$ , or simply  $y = \frac{3}{4}x$ .

## PRACTICE

1. Show that the points  $(-5, 1)$ ,  $(2, 0)$ , and  $(-2, -3)$  are the vertices of a right triangle.

2. Show that the points  $(-2, -3)$ ,  $(3, 6)$ ,  $(-5, 2)$ , and  $(6, 1)$  are the vertices of a parallelogram.
3. A sales representative earns a monthly base salary plus a commission on sales. Her pay this month will be \$2000 on sales of \$10,000. Last month, her pay was \$2720 on sales of \$16,000. Find an equation that gives her monthly pay in terms of her sales level.
4. The temperature scales Fahrenheit and Celsius are linearly related. Water freezes at  $0^{\circ}\text{C}$  and  $32^{\circ}\text{F}$ . Water boils at  $212^{\circ}\text{F}$  and  $100^{\circ}\text{C}$ . Find an equation that gives degrees Celsius in terms of degrees Fahrenheit.
5. A sales manager believes that each \$100 spent on television advertising results in an increase of 45 units sold. If sales were 8250 units sold when \$3600 was spent on television advertising, find an equation that gives the sales level in terms of the amount spent on advertising.

## SOLUTIONS

1.

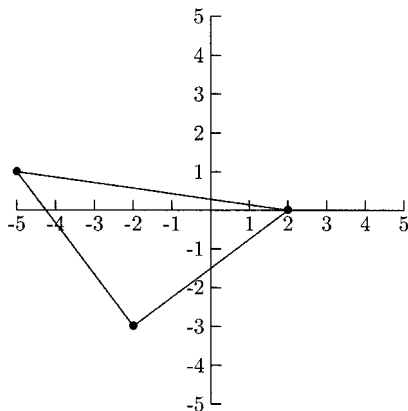

Fig. 1.16.

We will show that the slope of the line segment between  $(-5, 1)$  and  $(-2, -3)$  is the negative reciprocal of the slope of the line segment between  $(-2, -3)$  and  $(2, 0)$ . This will show that the angle at  $(-2, -3)$  is a right angle.

$$m = \frac{-3 - 1}{-2 - (-5)} = -\frac{4}{3}$$

$$m = \frac{0 - (-3)}{2 - (-2)} = \frac{3}{4}$$



2.

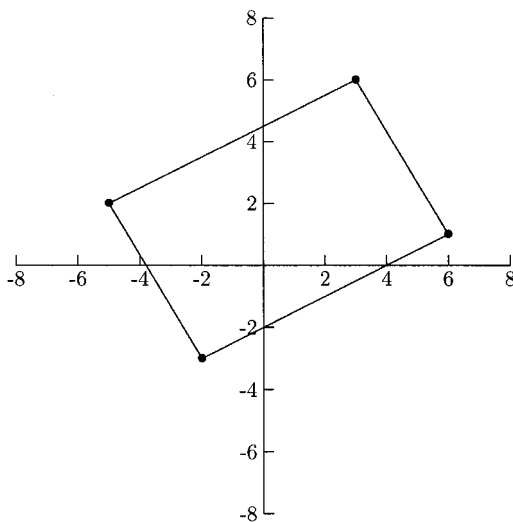

Fig. 1.17.

We will show that the slope of the line segment between  $(-5, 2)$  and  $(-2, -3)$  is equal to the slope of the line segment between  $(3, 6)$  and  $(6, 1)$ .

$$m = \frac{-3 - 2}{-2 - (-5)} = -\frac{5}{3} \qquad m = \frac{1 - 6}{6 - 3} = -\frac{5}{3}$$

Now we will show that the slope of the line segment between  $(-5, 2)$  and  $(3, 6)$  is equal to the slope of the line segment between  $(-2, -3)$  and  $(6, 1)$ .

$$m = \frac{6 - 2}{3 - (-5)} = \frac{1}{2} \qquad m = \frac{1 - (-3)}{6 - (-2)} = \frac{1}{2}$$

3. Because we want pay in terms of sales,  $y$  will represent pay, and  $x$  will represent monthly sales. The points are  $(10,000, 2000)$  and  $(16,000, 2720)$ .

$$m = \frac{2720 - 2000}{16,000 - 10,000} = \frac{3}{25}$$

(This means that for every \$25 in sales, the representative earns \$3.) We will use  $x = 10,000$ ,  $y = 2000$ , and  $m = \frac{3}{25}$  in  $y = mx + b$ .

$$2000 = \frac{3}{25}(10,000) + b$$

$$800 = b$$

The equation is  $y = \frac{3}{25}x + 800$ . (The  $y$ -intercept is 800 means that her monthly base pay is \$800.)

4. The points are (degrees Fahrenheit, degrees Celcius): (32, 0) and (212, 100).

$$m = \frac{100 - 0}{212 - 32} = \frac{5}{9}$$

(This means that a 9°F increase in temperature corresponds to an increase of 5°C.) We will use  $F = 32$ ,  $C = 0$ , and  $m = \frac{5}{9}$  in  $C = mF + b$ .

$$\begin{aligned} 0 &= \frac{5}{9}(32) + b \\ -\frac{160}{9} &= b \end{aligned}$$

The equation is  $C = \frac{5}{9}F - \frac{160}{9}$ . (The  $y$ -intercept is  $-\frac{160}{9}$  means that the temperature 0°F corresponds to  $-\frac{160}{9}$ °C.)

5. The points are (amount spent on advertising, number of units sold). The slope is

$$\frac{\text{increase in sales}}{\text{increase in advertising spending}} = \frac{45}{100} = \frac{9}{20},$$

and our point is (3600, 8250).

$$\begin{aligned} 8250 &= \frac{9}{20}(3600) + b \\ 6630 &= b \end{aligned}$$

The equation is  $y = \frac{9}{20}x + 6630$ . (The slope means that every \$20 spent on television advertising results in an extra 9 units sold. The  $y$ -intercept is 6630 means that if nothing is spent on television advertising, 6630 units would be sold.)

## CHAPTER 1 REVIEW

1. Find the slope of the line containing the points (3, 1) and (4, -2).  
 (a)  $\frac{1}{3}$       (b) -3      (c)  $-\frac{1}{3}$       (d) 3

2. Are the lines  $2x + y = 4$  and  $2x - 4y = 5$  parallel, perpendicular, or neither?
- (a) Parallel (b) Perpendicular  
(c) Neither (d) Cannot be determined
3. Are the lines  $x = 4$  and  $y = -4$  parallel, perpendicular, or neither?
- (a) Parallel (b) Perpendicular  
(c) Neither (d) Cannot be determined
4. What is the equation of the line containing the points  $(0, -1)$  and  $(5, 1)$ ?
- (a)  $y = -1$  (b)  $y = \frac{5}{2}x - 1$   
(c)  $y = -4x - 1$  (d)  $y = \frac{2}{5}x - 1$
5. Find an equation of the line containing the point  $(-1, -5)$  and parallel to the line  $y = 2x - 4$ .
- (a)  $y = 2x - 3$  (b)  $y = 2x - 5$   
(c)  $y = 2x - 1$  (d)  $y = 2x + 4$
6. Find an equation of the line containing the point  $(3, 3)$  and perpendicular to the line  $y = 2x + 5$ .
- (a)  $y = -\frac{1}{2}x + \frac{9}{2}$  (b)  $y = \frac{1}{2}x + 3$   
(c)  $y = \frac{1}{2}x + \frac{3}{2}$  (d)  $y = -\frac{1}{2}x + 3$
7. Find an equation of the line in Figure 1.18.
- (a)  $y = -\frac{1}{2}x + 4$  (b)  $y = \frac{1}{2}x + 4$   
(c)  $y = -2x + 4$  (d)  $y = 2x + 4$

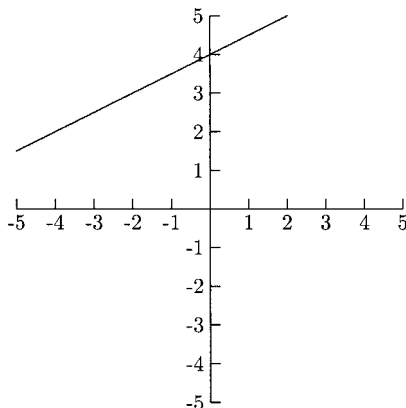
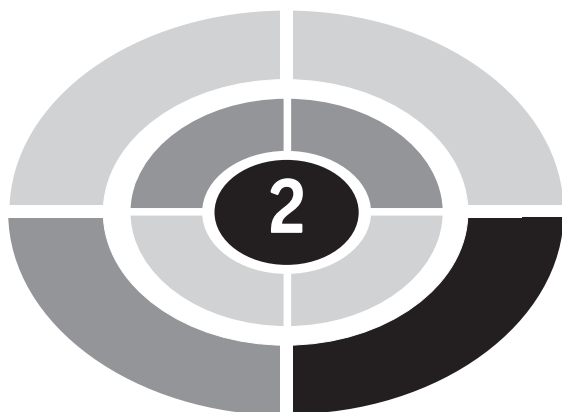

Fig. 1.18.

8. Find an equation of the horizontal line that goes through the point (4, 9).
  - (a)  $x = 4$
  - (b)  $y = 9$
  - (c) Cannot be determined
9. Are the points  $(-5, -1)$ ,  $(1, 4)$ , and  $(6, -2)$  the vertices of a right triangle?
  - (a) Yes
  - (b) No
  - (c) Cannot be determined
10. A government agency leases a photocopier for a fixed monthly charge plus a charge for each photocopy. In one month, the bill was \$350 for 4000 copies. In the following month, the bill was \$375 for 5000 copies. Find the monthly bill in terms of the number of copies used.
  - (a)  $y = 1.267x - 4718$
  - (b)  $y = 40x - 10,000$
  - (c)  $y = 0.789x - 3570$
  - (d)  $y = 0.025x + 250$

## SOLUTIONS

- |      |      |      |      |       |
|------|------|------|------|-------|
| 1. B | 2. B | 3. B | 4. D | 5. A  |
| 6. A | 7. B | 8. B | 9. A | 10. D |



## CHAPTER

# Introduction to Functions

A *relation* between two sets  $A$  and  $B$  is a collection of ordered pairs, where the first coordinate comes from  $A$  and the second comes from  $B$ . For example, if  $A = \{1, 2, 3, 4\}$  and  $B = \{a, b, c\}$ , one relation is the three pairs  $\{(1, c), (1, a), (3, a)\}$ . A *function* on sets  $A$  and  $B$  is a special kind of relation where *every* element of  $A$  is paired with *exactly one* element from  $B$ . The relation above fails to be a function in two ways. Not every element of  $A$  is paired with an element from  $B$ , 1 and 3 are used but not 2 and 4. Also, the element 1 is used *twice*, not *once*. There are no such restrictions on  $B$ ; that is, elements from  $B$  can be paired with elements from  $A$  many times or not at all. For example,  $\{(1, a), (2, a), (3, b), (4, b)\}$  is a function from  $A$  to  $B$ .

Functions exist all around us. If a worker is paid by the hour, his weekly pay is a function of how many hours he worked. For any number of hours worked, there is exactly one pay amount that corresponds to that time. If  $A$  is the set of all triangles and  $B$  is the set of real numbers, then we have a function that pairs each triangle with exactly one real number that is its area. We will be concerned with functions

XI

from real numbers to real numbers.  $A$  will either be all of the real numbers or will be some part of the real numbers, and  $B$  will be the real numbers.

A linear function is one of the most basic kinds of functions. These functions have the form  $f(x) = mx + b$ . The only difference between  $f(x) = mx + b$  and  $y = mx + b$  is that  $y$  is replaced by  $f(x)$ . Very often  $f(x)$  and  $y$  will be the same. The letter  $f$  is the name of the function. Other common names of functions are  $g$  and  $h$ . The notation  $f(x)$  is pronounced “ $f$  of  $x$ ” or “ $f$  at  $x$ .”

Evaluating a function at a quantity means to substitute the quantity for  $x$  (or whatever the variable is). For example, evaluating the function  $f(x) = 2x - 5$  at 6 means to substitute 6 for  $x$ .

$$f(6) = 2(6) - 5 = 7$$

We might also say  $f(6) = 7$ . The quantity inside the parentheses is  $x$  and the quantity on the right of the equal sign is  $y$ . One advantage to this notation is that we have both the  $x$ - and  $y$ -values without having to say anything about  $x$  and  $y$ . Functions that have no variables in them are called *constant functions*. All  $y$ -values for these functions are the same.

## EXAMPLES

- Find  $f(-2)$ ,  $f(0)$ , and  $f(6)$  for  $f(x) = \sqrt{x+3}$ .  
We need to substitute  $-2$ ,  $0$ , and  $6$  for  $x$  in the function.

$$f(-2) = \sqrt{-2+3} = \sqrt{1} = 1$$

$$f(0) = \sqrt{0+3} = \sqrt{3}$$

$$f(6) = \sqrt{6+3} = \sqrt{9} = 3$$

- Find  $f(-8)$ ,  $f(\pi)$ , and  $f(10)$  for  $f(x) = 16$ .  
 $f(x) = 16$  is a constant function, so the  $y$ -value is 16 no matter what quantity is in the parentheses.

$$f(-8) = 16$$

$$f(\pi) = 16$$

$$f(10) = 16$$

A *piecewise* function is a function with two or more formulas for computing  $y$ . The formula to use depends on where  $x$  is. There will be an interval for  $x$  written next to each formula for  $y$ .

$$f(x) = \begin{cases} x - 1 & \text{if } x \leq -2 \\ 2x & \text{if } -2 < x < 2 \\ x^2 & \text{if } x \geq 2 \end{cases}$$

In this example, there are three formulas for  $y$ :  $y = x - 1$ ,  $y = 2x$ , and  $y = x^2$ , and three intervals for  $x$ :  $x \leq -2$ ,  $-2 < x < 2$ , and  $x \geq 2$ . When evaluating this function, we need to decide to which interval  $x$  belongs. Then we will use the corresponding formula for  $y$ .

## EXAMPLES

- Find  $f(5)$ ,  $f(-3)$ , and  $f(0)$  for the function above.  
For  $f(5)$ , does  $x = 5$  belong to  $x \leq -2$ ,  $-2 < x < 2$ , or  $x \geq 2$ ? Because  $5 \geq 2$ , we will use  $y = x^2$ , the formula written next to  $x \geq 2$ .

$$f(5) = 5^2 = 25$$

For  $f(-3)$ , does  $x = -3$  belong to  $x \leq -2$ ,  $-2 < x < 2$ , or  $x \geq 2$ ? Because  $-3 \leq -2$ , we will use  $y = x - 1$ , the formula written next to  $x \leq -2$ .

$$f(-3) = -3 - 1 = -4$$

For  $f(0)$ , does  $x = 0$  belong to  $x \leq -2$ ,  $-2 < x < 2$ , or  $x \geq 2$ ? Because  $-2 < 0 < 2$ , we will use  $y = 2x$ , the formula written next to  $-2 < x < 2$ .

$$f(0) = 2(0) = 0$$

- Find  $f(3)$ ,  $f(1)$ , and  $f(-4)$  for

$$f(x) = \begin{cases} -x & \text{if } x \leq 1 \\ 5 & \text{if } x > 1 \end{cases}$$

$$f(3) = 5 \qquad \text{because } 3 > 1$$

$$f(1) = -1 \qquad \text{because } 1 \leq 1$$

$$f(-4) = -(-4) = 4 \qquad \text{because } -4 \leq 1$$

Piecewise functions come up in daily life. For example, suppose a company pays the regular hourly wage for someone who works up to eight hours but time and a half for someone who works more than eight hours but no more than ten hours and double time for more than ten hours. Then a worker whose regular hourly pay is \$10 has the daily pay function below.

$$p(h) = \begin{cases} 10h & \text{if } 0 \leq h \leq 8 \\ 15(h - 8) + 80 & \text{if } 8 < h \leq 10 \\ 20(h - 10) + 110 & \text{if } 10 < h \leq 24 \end{cases}$$

Below is an example of a piecewise function taken from an Internal Revenue Service (IRS) publication. The  $y$ -value is the amount of personal income tax for a single person. The  $x$ -value is the amount of taxable income.

$$f(x) = \begin{cases} 4316 & \text{if } 30,000 \leq x < 30,050 \\ 4329 & \text{if } 30,050 \leq x < 30,100 \\ 4341 & \text{if } 30,100 \leq x < 30,150 \\ 4354 & \text{if } 30,150 \leq x < 30,200 \end{cases}$$

A single person whose taxable income was \$30,120 would pay \$4341. (Source: 2003, 1040 Forms and Instructions)

### PRACTICE

1. Find  $f(-1)$  and  $f(0)$  for  $f(x) = 3x^2 + 2x - 1$ .
2. Evaluate  $f(x) = \frac{1}{x+1}$  at  $x = -3$ ,  $x = 1$ , and  $x = \frac{1}{2}$ .
3. Evaluate  $g(x) = \sqrt{x-6}$  at  $x = 6$ ,  $x = 8$ , and  $x = 10$ .
4. Find  $f(5)$ ,  $f(3)$ ,  $f(2)$ ,  $f(0)$ , and  $f(-1)$ .

$$f(x) = \begin{cases} x^2 + x & \text{if } x \leq -1 \\ 10 & \text{if } -1 < x \leq 2 \\ -6x & \text{if } x > 2 \end{cases}$$

5. The function below gives the personal income tax for a single person for the 2003 year. If a single person had a taxable income of \$63,575, what is her tax?

$$f(x) = \begin{cases} 12,666 & \text{if } 63,400 \leq x < 63,450 \\ 12,679 & \text{if } 63,450 \leq x < 63,500 \\ 12,691 & \text{if } 63,500 \leq x < 63,550 \\ 12,704 & \text{if } 63,550 \leq x < 63,600 \end{cases}$$

### SOLUTIONS

1.  $f(-1) = 3(-1)^2 + 2(-1) - 1 = 3 - 2 - 1 = 0$   
 $f(0) = 3(0)^2 + 2(0) - 1 = -1$



$$2. \quad f(-3) = \frac{1}{-3+1} = \frac{1}{-2} \text{ or } -\frac{1}{2}$$

$$f(1) = \frac{1}{1+1} = \frac{1}{2}$$

$$f\left(\frac{1}{2}\right) = \frac{1}{\frac{1}{2}+1} = \frac{1}{\frac{1}{2}+\frac{2}{2}} = \frac{1}{\frac{3}{2}} = 1 \div \frac{3}{2} = 1 \cdot \frac{2}{3} = \frac{2}{3}$$

$$3. \quad g(6) = \sqrt{6-6} = \sqrt{0} = 0$$

$$g(8) = \sqrt{8-6} = \sqrt{2}$$

$$g(10) = \sqrt{10-6} = \sqrt{4} = 2$$

$$4. \quad f(5) = -6(5) = -30 \qquad f(3) = -6(3) = -18$$

$$f(2) = 10 \qquad f(0) = 10$$

$$f(-1) = (-1)^2 + (-1) = 0$$

5. The tax is \$12,704 because  $63,550 \leq 63,575 < 63,600$ .

Functions can be evaluated at quantities that are not numbers, but the idea is the same—substitute the quantity in the parentheses for  $x$  and simplify.

## EXAMPLES

- Evaluate  $f(a+3)$ ,  $f(a^2)$ ,  $f(u-v)$ , and  $f(a+h)$  for  $f(x) = 8x + 5$ . We will let  $x = a+3$ ,  $x = a^2$ ,  $x = u-v$ , and  $x = a+h$  in the function.

$$f(a+3) = 8(a+3) + 5 = 8a + 24 + 5 = 8a + 29$$

$$f(a^2) = 8(a^2) + 5 = 8a^2 + 5$$

$$f(u-v) = 8(u-v) + 5 = 8u - 8v + 5$$

$$f(a+h) = 8(a+h) + 5 = 8a + 8h + 5$$

- Evaluate  $f(10a)$ ,  $f(-a)$ ,  $f(a+h)$ , and  $f(x+1)$  for  $f(x) = x^2 + 3x - 4$ .

$$f(10a) = (10a)^2 + 3(10a) - 4 = 10^2a^2 + 30a - 4 = 100a^2 + 30a - 4$$

$$f(-a) = (-a)^2 + 3(-a) - 4 = a^2 - 3a - 4$$

Remember,  $(-a)^2 = (-a)(-a) = a^2$ , not  $-a^2$ .

$$f(a+h) = (a+h)^2 + 3(a+h) - 4 = (a+h)(a+h) + 3(a+h) - 4$$

$$= a^2 + 2ah + h^2 + 3a + 3h - 4$$

$$f(x+1) = (x+1)^2 + 3(x+1) - 4 = (x+1)(x+1) + 3(x+1) - 4$$

$$= x^2 + 2x + 1 + 3x + 3 - 4 = x^2 + 5x$$

- Find  $f(a-12)$ ,  $f(a^2+1)$ ,  $f(a+h)$ , and  $f(x+3)$  for  $f(x) = -4$ . This is a constant function, so the  $y$ -value is  $-4$  no matter what is in the parentheses.

$$f(a-12) = -4$$

$$f(a^2+1) = -4$$

$$f(a+h) = -4$$

$$f(x+3) = -4$$

- Find  $f(2u+v)$ ,  $f\left(\frac{1}{u}\right)$ , and  $f(2x)$  for

$$f(x) = \frac{x+1}{x+2}$$

$$f(2u+v) = \frac{2u+v+1}{2u+v+2}$$

$$f\left(\frac{1}{u}\right) = \frac{\frac{1}{u}+1}{\frac{1}{u}+2} = \frac{\frac{1}{u} + \frac{u}{u} \cdot 1}{\frac{1}{u} + \frac{u}{u} \cdot 2}$$

$$= \frac{\frac{1}{u} + \frac{u}{u}}{\frac{1}{u} + \frac{2u}{u}} = \frac{\frac{1+u}{u}}{\frac{1+2u}{u}}$$

$$= \frac{1+u}{u} \div \frac{1+2u}{u} = \frac{1+u}{u} \cdot \frac{u}{1+2u} = \frac{1+u}{1+2u}$$

$$f(2x) = \frac{2x+1}{2x+2}$$

Very early in an introductory calculus course, students use function evaluation to evaluate an important formula called *Newton's Quotient*.

$$\frac{f(a+h) - f(a)}{h}$$

When evaluating Newton's Quotient, we will be given a function such as  $f(x) = x^2 + 3$ . We need to find  $f(a+h)$  and  $f(a)$ . Once we have these two quantities, we will put them into the quotient and simplify. Simplifying the quotient is usually the messiest part. For  $f(x) = x^2 + 3$ , we have  $f(a+h) = (a+h)^2 + 3 = (a+h)(a+h) + 3 = a^2 + 2ah + h^2 + 3$ , and  $f(a) = a^2 + 3$ . We will substitute  $a^2 + 2ah + h^2 + 3$  for  $f(a+h)$  and  $a^2 + 3$  for  $f(a)$ .

$$\frac{f(a+h) - f(a)}{h} = \frac{\overbrace{a^2 + 2ah + h^2 + 3}^{f(a+h)} - \overbrace{(a^2 + 3)}^{f(a)}}{h}$$

Now we need to simplify this fraction.

$$\begin{aligned} \frac{a^2 + 2ah + h^2 + 3 - (a^2 + 3)}{h} &= \frac{a^2 + 2ah + h^2 + 3 - a^2 - 3}{h} \\ &= \frac{2ah + h^2}{h} && \text{Factor } h. \\ &= \frac{h(2a + h)}{h} = 2a + h \end{aligned}$$

## EXAMPLES

Evaluate Newton's Quotient for the given functions.

- $f(x) = 3x^2$

$$\begin{aligned} f(a+h) &= 3(a+h)^2 = 3(a+h)(a+h) = 3(a^2 + 2ah + h^2) \\ &= 3a^2 + 6ah + 3h^2 \end{aligned}$$

$$f(a) = 3a^2$$

$$\begin{aligned} \frac{f(a+h) - f(a)}{h} &= \frac{3a^2 + 6ah + 3h^2 - 3a^2}{h} = \frac{6ah + 3h^2}{h} \\ &= \frac{h(6a + 3h)}{h} = 6a + 3h \end{aligned}$$

- $f(x) = x^2 - 2x + 5$

$$f(a+h) = (a+h)^2 - 2(a+h) + 5 = (a+h)(a+h) - 2(a+h) + 5$$

$$= a^2 + 2ah + h^2 - 2a - 2h + 5$$

$$f(a) = a^2 - 2a + 5$$

$$\frac{f(a+h) - f(a)}{h} = \frac{a^2 + 2ah + h^2 - 2a - 2h + 5 - (a^2 - 2a + 5)}{h}$$

$$= \frac{a^2 + 2ah + h^2 - 2a - 2h + 5 - a^2 + 2a - 5}{h}$$

$$= \frac{2ah + h^2 - 2h}{h} = \frac{h(2a + h - 2)}{h}$$

$$= 2a + h - 2$$

- $f(x) = \frac{1}{x}$

$$f(a+h) = \frac{1}{a+h} \quad \text{and} \quad f(a) = \frac{1}{a}$$

$$\frac{f(a+h) - f(a)}{h} = \frac{\frac{1}{a+h} - \frac{1}{a}}{h}$$

$$= \frac{\frac{1}{a+h} \cdot \frac{a}{a} - \frac{1}{a} \cdot \frac{a+h}{a+h}}{h}$$

$$= \frac{\frac{a}{a(a+h)} - \frac{a+h}{a(a+h)}}{h}$$

$$= \frac{\frac{a-(a+h)}{a(a+h)}}{h} = \frac{\frac{a-a-h}{a(a+h)}}{h}$$

$$= \frac{\frac{-h}{a(a+h)}}{h} = \frac{-h}{a(a+h)} \div h$$

$$= \frac{-h}{a(a+h)} \cdot \frac{1}{h} = \frac{-1}{a(a+h)}$$

Do not worry—you will not spend a lot of time evaluating Newton's Quotient in calculus, there are formulas that do most of the work. What is Newton's Quotient,

anyway? It is nothing more than the slope formula where  $x_1 = a$ ,  $y_1 = f(a)$ ,  $x_2 = a + h$ , and  $y_2 = f(a + h)$ .

$$m = \frac{y_2 - y_1}{x_2 - x_1} = \frac{f(a + h) - f(a)}{a + h - a} = \frac{f(a + h) - f(a)}{h}$$

## PRACTICE

1. Evaluate  $f(u + 1)$ ,  $f(u^3)$ ,  $f(a + h)$ , and  $f(2x - 1)$  for  $f(x) = 7x - 4$ .
2. Find  $f(-a)$ ,  $f(2a)$ ,  $f(a + h)$ , and  $f(x + 5)$  for  $f(x) = 2x^2 - x + 3$ .
3. Find  $f(u + v)$ ,  $f(u^2)$ ,  $f(\frac{1}{u})$ , and  $f(x^2 + 3)$  for

$$f(x) = \frac{10x + 1}{3x + 2}$$

4. Evaluate Newton's Quotient for  $f(x) = 3x^2 + 2x - 1$ .
5. Evaluate Newton's Quotient for  $f(x) = \frac{15}{2x-3}$ .

## SOLUTIONS

$$1. \quad f(u + 1) = 7(u + 1) - 4 = 7u + 7 - 4 = 7u + 3$$

$$f(u^3) = 7(u^3) - 4 = 7u^3 - 4$$

$$f(a + h) = 7(a + h) - 4 = 7a + 7h - 4$$

$$f(2x - 1) = 7(2x - 1) - 4 = 14x - 7 - 4 = 14x - 11$$

$$2. \quad f(-a) = 2(-a)^2 - (-a) + 3 = 2a^2 + a + 3$$

$$f(2a) = 2(2a)^2 - 2a + 3 = 2(4a^2) - 2a + 3 = 8a^2 - 2a + 3$$

$$f(a + h) = 2(a + h)^2 - (a + h) + 3 = 2(a + h)(a + h) - (a + h) + 3$$

$$= 2(a^2 + 2ah + h^2) - a - h + 3 = 2a^2 + 4ah + 2h^2 - a - h + 3$$

$$f(x + 5) = 2(x + 5)^2 - (x + 5) + 3 = 2(x + 5)(x + 5) - (x + 5) + 3$$

$$= 2(x^2 + 10x + 25) - x - 5 + 3 = 2x^2 + 19x + 48$$

$$3. \quad f(u+v) = \frac{10(u+v)+1}{3(u+v)+2} = \frac{10u+10v+1}{3u+3v+2}$$

$$f(u^2) = \frac{10u^2+1}{3u^2+2}$$

$$f\left(\frac{1}{u}\right) = \frac{10\left(\frac{1}{u}\right)+1}{3\left(\frac{1}{u}\right)+2}$$

$$= \frac{\frac{10}{u}+1}{\frac{3}{u}+2} = \frac{\frac{10}{u}+1 \cdot \frac{u}{u}}{\frac{3}{u}+2 \cdot \frac{u}{u}} = \frac{\frac{10}{u}+\frac{u}{u}}{\frac{3}{u}+\frac{2u}{u}}$$

$$= \frac{\frac{10+u}{u}}{\frac{3+2u}{u}} = \frac{10+u}{u} \div \frac{3+2u}{u}$$

$$= \frac{10+u}{u} \cdot \frac{u}{3+2u} = \frac{10+u}{3+2u}$$

$$f(x^2+3) = \frac{10(x^2+3)+1}{3(x^2+3)+2}$$

$$= \frac{10x^2+31}{3x^2+11}$$

$$4. \quad f(a+h) = 3(a+h)^2 + 2(a+h) - 1 = 3(a+h)(a+h) + 2(a+h) - 1$$

$$= 3(a^2 + 2ah + h^2) + 2a + 2h - 1$$

$$= 3a^2 + 6ah + 3h^2 + 2a + 2h - 1$$

$$f(a) = 3a^2 + 2a - 1$$

$$\frac{f(a+h) - f(a)}{h} = \frac{3a^2 + 6ah + 3h^2 + 2a + 2h - 1 - (3a^2 + 2a - 1)}{h}$$

$$= \frac{3a^2 + 6ah + 3h^2 + 2a + 2h - 1 - 3a^2 - 2a + 1}{h}$$

$$= \frac{6ah + 3h^2 + 2h}{h}$$

$$= \frac{h(6a + 3h + 2)}{h} = 6a + 3h + 2$$

$$5. \quad f(a+h) = \frac{15}{2(a+h)-3} = \frac{15}{2a+2h-3} \text{ and } f(a) = \frac{15}{2a-3}$$

$$\begin{aligned} \frac{f(a+h) - f(a)}{h} &= \frac{\frac{15}{2a+2h-3} - \frac{15}{2a-3}}{h} \\ &= \frac{\frac{15}{2a+2h-3} \cdot \frac{2a-3}{2a-3} - \frac{15}{2a-3} \cdot \frac{2a+2h-3}{2a+2h-3}}{h} \\ &= \frac{\frac{15(2a-3) - 15(2a+2h-3)}{(2a+2h-3)(2a-3)}}{h} = \frac{\frac{30a-45-30a-30h+45}{(2a+2h-3)(2a-3)}}{h} \\ &= \frac{\frac{-30h}{(2a+2h-3)(2a-3)}}{h} = \frac{-30h}{(2a+2h-3)(2a-3)} \div h \\ &= \frac{-30h}{(2a+2h-3)(2a-3)} \cdot \frac{1}{h} = \frac{-30}{(2a+2h-3)(2a-3)} \end{aligned}$$

## Domain and Range

The *domain* of a function from set  $A$  to set  $B$  is all of set  $A$ . The *range* is either all or part of set  $B$ . In our example at the beginning of the chapter, we had  $A = \{1, 2, 3, 4\}$ ,  $B = \{a, b, c\}$  and our function was  $\{(1, a), (2, a), (3, b), (4, b)\}$ . The domain of this function is  $\{1, 2, 3, 4\}$ , and the range is all of the elements from  $B$  that were paired with elements from  $A$ . These were  $\{a, b\}$ .

For the functions in this book, the domain will consist of all the real numbers we are allowed to use for  $x$ . The range will be all of the  $y$ -values. In this chapter, we will find the domain algebraically. In Chapter 3, we will find both the domain and range from graphs of functions.

Very often, we find the domain of a function by thinking about what we cannot do. For now the things we cannot do are limited to division by zero and taking even roots of negative numbers. If a function has  $x$  in a denominator, set the denominator equal to zero and solve for  $x$ . The domain will *not* include the solution(s) to this equation (assuming the equation has a solution). If a function has  $x$  under an even root sign, set the quantity under the sign greater than or equal to zero to find the domain. Later when we learn about logarithm functions and functions from trigonometry, we will have other things we cannot do. The domain and range are

usually given in interval notation. There is a review of interval notation in the Appendix.

## EXAMPLES

- $f(x) = \frac{x^2 - 4}{x + 3}$

We cannot let  $x + 3$  be zero, so we cannot let  $x = -3$ . The domain is  $x \neq -3$ , or  $(-\infty, -3) \cup (-3, \infty)$ .

- $f(x) = \frac{1}{x^3 + 2x^2 - x - 2}$

We will use factoring by grouping to factor the denominator. (There is a review of factoring by grouping in the Appendix.)

$$x^3 + 2x^2 - x - 2 = 0$$

$$x^2(x + 2) - 1(x + 2) = 0$$

$$(x + 2)(x^2 - 1) = 0$$

$$(x + 2)(x - 1)(x + 1) = 0$$

$$x + 2 = 0$$

$$x = -2$$

$$x - 1 = 0$$

$$x = 1$$

$$x + 1 = 0$$

$$x = -1$$

The domain is all real numbers except 1, -1, and -2. The domain is shaded on the number line in Figure 2.1.

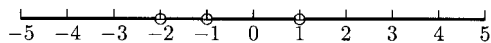

Fig. 2.1.

The domain is  $(-\infty, -2) \cup (-2, -1) \cup (-1, 1) \cup (1, \infty)$ .

- $g(x) = \frac{x + 5}{x^2 + 1}$

Because  $x^2 + 1 = 0$  has no real number solution, we can let  $x$  equal any real number. The domain is all real numbers, or  $(-\infty, \infty)$ .



- $f(x) = \sqrt{x - 8}$

Because we can only take the square root of nonnegative numbers,  $x - 8$  must be nonnegative. We represent “ $x - 8$  must be nonnegative” as “ $x - 8 \geq 0$ .” Solving  $x - 8 \geq 0$ , we get  $x \geq 8$ . The domain is  $x \geq 8$ , or  $[8, \infty)$ .

- $f(x) = \sqrt{x^2 - x - 2}$

(The Appendix has a review on solving nonlinear inequalities.) We need to solve  $x^2 - x - 2 \geq 0$ . Factoring  $x^2 - x - 2$ , we have  $(x - 2)(x + 1)$ .

$$\begin{array}{rcl} x - 2 = 0 & & x + 1 = 0 \\ x = 2 & & x = -1 \end{array}$$

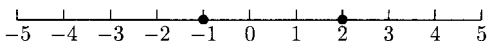

Fig. 2.2.

We will use  $x = -2$  for the number to the left of  $-1$ ,  $x = 0$  for the number between  $-1$  and  $2$ , and  $x = 3$  for the number to the right of  $2$  in  $x^2 - x - 2 \geq 0$  to see which of these numbers makes it true.

Is  $(-2)^2 - (-2) - 2 \geq 0$ ? Yes. Put “True” to the left of  $-1$ .

Is  $0^2 - 0 - 2 \geq 0$ ? No. Put “False” between  $-1$  and  $2$ .

Is  $3^2 - 3 - 2 \geq 0$ ? Yes. Put “True” to the right of  $2$ .

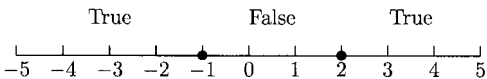

Fig. 2.3.

The inequality is true for  $x \leq -1$  and  $x \geq 2$ , so the domain is  $(-\infty, -1] \cup [2, \infty)$ .

- $f(x) = \sqrt[4]{x^2 + 5}$

Because  $x^2 + 5$  is always positive, we can let  $x$  be any real number. The domain is  $(-\infty, \infty)$ .

- $g(x) = \sqrt[3]{x + 7}$

We can take the cube root of any number, so the domain is all real numbers, or  $(-\infty, \infty)$ .

- $f(x) = x^4 - x^2 + 1$

There is no  $x$  in a denominator and no  $x$  under an even root sign, so the domain is all real numbers, or  $(-\infty, \infty)$ .

There are some functions that have  $x$  in a denominator and under an even root. At times, it will be useful to shade a number line to keep track of the domain.

- $f(x) = \frac{x^2 + x - 3}{\sqrt{4 - x}}$

We cannot let  $\sqrt{4 - x}$  be zero, and we cannot let  $4 - x$  be negative. These restrictions mean that we must have  $4 - x > 0$  (instead of  $4 - x \geq 0$ ). The domain is  $4 > x$  (or  $x < 4$ ), which is the interval  $(-\infty, 4)$ .

- $h(x) = \frac{15 - x}{x^2 + 3x - 4} + \sqrt{x + 10}$

For  $\sqrt{x + 10}$  we need  $x + 10 \geq 0$ , or  $x \geq -10$ .

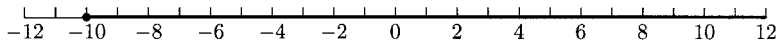

Fig. 2.4.

We also need for  $x^2 + 3x - 4$  not to be zero.

$$x^2 + 3x - 4 = 0$$

$$(x + 4)(x - 1) = 0$$

$$x + 4 = 0$$

$$x - 1 = 0$$

$$x = -4$$

$$x = 1$$

We cannot let  $x = -4$  and  $x = 1$ , so we will remove these numbers from  $x \geq -10$ . The domain is  $[-10, -4) \cup (-4, 1) \cup (1, \infty)$ .

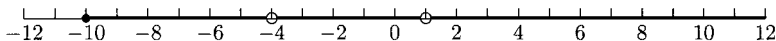

Fig. 2.5.

**PRACTICE**

For Problems 2–11, give the domain in interval notation.

1. A function consists of the ordered pairs  $\{(h, 5), (z, 3), (i, 12)\}$ . List the elements in the domain.
2.  $f(x) = \frac{2x + 3}{x - 8}$
3.  $f(x) = \frac{-1}{x^2 - 2x}$
4.  $f(x) = \frac{x - 3}{x^2 + 10}$
5.  $g(x) = \sqrt[3]{6 - x}$
6.  $h(x) = \sqrt{x + 3}$
7.  $f(x) = \sqrt{4 - x^2}$
8.  $f(x) = \sqrt{3x^2 + 5}$
9.  $f(x) = \frac{1}{\sqrt{x - 9}}$
10.  $f(x) = 4x^3 - 2x + 5$
11.  $f(x) = \frac{\sqrt{x + 5}}{x^2 + 2x - 8}$

**SOLUTIONS**

1. The domain consists of the first coordinate of the ordered pairs— $h$ ,  $z$ , and  $i$ .
2. We cannot let  $x - 8 = 0$ , so we cannot let  $x = 8$ . The domain is  $x \neq 8$ , or  $(-\infty, 8) \cup (8, \infty)$ .
3. We cannot let  $x^2 - 2x = x(x - 2) = 0$ , so we cannot let  $x = 0$  or  $x = 2$ . The domain is all real numbers except 0 and 2, or  $(-\infty, 0) \cup (0, 2) \cup (2, \infty)$ .
4. Because  $x^2 + 10 = 0$  has no real number solution, the domain is all real numbers, or  $(-\infty, \infty)$ .
5. We can take the cube root of any number, so the domain is all real numbers, or  $(-\infty, \infty)$ .
6. We must have  $x + 3 \geq 0$ , or  $x \geq -3$ . The domain is  $[-3, \infty)$ .

7. We need to solve  $4 - x^2 = (2 - x)(2 + x) \geq 0$ .

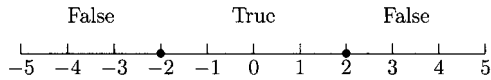

Fig. 2.6.

The domain is  $[-2, 2]$ .

8. Because  $3x^2 + 5 \geq 0$  is true for all real numbers, the domain is  $(-\infty, \infty)$ .
9. We need  $x - 9 > 0$ . The domain is  $x > 9$ , or  $(9, \infty)$ .
10. The domain is all real numbers, or  $(-\infty, \infty)$ .
11. From  $x + 5 \geq 0$ , we have  $x \geq -5$ .

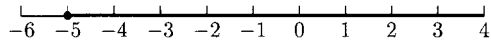

Fig. 2.7.

Now we need to solve  $x^2 + 2x - 8 = (x + 4)(x - 2) = 0$ .

$$\begin{array}{ll} x + 4 = 0 & x - 2 = 0 \\ x = -4 & x = 2 \end{array}$$

Now we need to remove  $-4$  and  $2$  from  $x \geq -5$ . The domain is  $[-5, -4) \cup (-4, 2) \cup (2, \infty)$ .

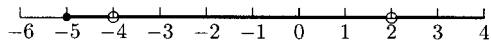

Fig. 2.8.

At times the domain of a function will matter when we are solving an applied problem. For example, suppose there is a  $10'' \times 18''$  piece of cardboard that will be made into an open-topped box. After cutting a square  $x$  by  $x$  inches from each corner, the sides will be folded up to form the box.

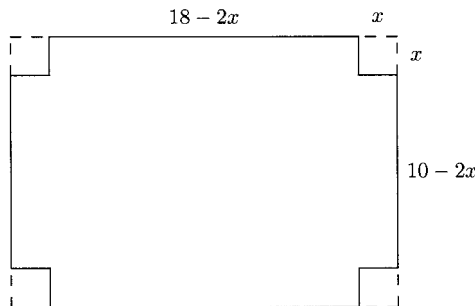

Fig. 2.9.

The volume of the box is a function of  $x$ ,  $V(x) = x(18 - 2x)(10 - 2x)$ . What is the domain of this function? We obviously cannot cut a negative number of inches from each corner. If we cut 0 inches from each corner, we do not have a box, so  $x$  must be positive. Finally, the box is only 10 inches wide, so we can cut up to five inches from each corner. These facts make the domain  $0 < x < 5$ . Maximizing the volume of this box is a typical problem in a first semester of calculus. The solutions to the mathematical problem are  $\frac{14 \pm \sqrt{61}}{3}$  (approximately 2.0635, and 7.27008). Only one of these numbers is in the domain of the applied function, so only one of these numbers is the solution.

## CHAPTER 2 REVIEW

- Evaluate  $f(x) = 4 - 2x^2$  at  $x = 3$ .  
 (a)  $-14$       (b)  $-12$       (c)  $-10$       (d)  $-8$
- Evaluate  $f(-1)$  for

$$f(x) = \begin{cases} 5 & \text{if } x < 0 \\ x + 3 & \text{if } x \geq 0 \end{cases}$$

- (a)  $-1$       (b)  $5$       (c)  $2$       (d)  $2, 5$
- Evaluate  $f(u^2 + v)$  for  $f(x) = 4x + 6$ .  
 (a)  $(u^2 + v)(4x + 6)$       (b)  $4u^2 + v + 6$   
 (c)  $4v^2x + 6$       (d)  $4u^2 + 4v + 6$
- What is the domain for  $f(x) = \sqrt{x^2 + 1}$ ?  
 (a)  $(-\infty, \infty)$       (b)  $(-\infty, -1] \cup [1, \infty)$   
 (c)  $(-\infty, -1) \cup (1, \infty)$       (d)  $[-1, 1]$
- Evaluate  $\frac{f(a+h)-f(a)}{h}$  for  $f(x) = x^2 + 3$ .  
 (a)  $2a + h^2$       (b)  $2a + h^2 + 3$   
 (c)  $2a + h$       (d)  $2a + h + 3$
- What is the domain for  $f(x) = \sqrt{x - 5}$ ?  
 (a)  $(-\infty, 5) \cup (5, \infty)$       (b)  $[5, \infty)$   
 (c)  $(-\infty, 5]$       (d)  $(-\infty, -5) \cup (5, \infty)$

7. What is the domain for  $f(x) = \frac{1}{x^2-9}$ ?
- (a)  $(-\infty, 9) \cup (9, \infty)$                       (b)  $(-\infty, 3) \cup (3, \infty)$   
 (c)  $[3, \infty)$     (d)  $(-\infty, -3) \cup (-3, 3) \cup (3, \infty)$

8. What is the domain for the function  $\{(a, 6), (b, 6), (d, 9)\}$ ?
- (a)  $\{a, b, d\}$     (b)  $\{6, 9\}$   
 (c)  $\{a, b, d, 6, 9\}$                                       (d)  $\{a, b, d, 9\}$

9. What is the domain for

$$f(x) = \frac{x-5}{\sqrt{x-4}}?$$

- (a)  $[4, 5) \cup (5, \infty)$                                   (b)  $(-\infty, 4) \cup (4, \infty)$   
 (c)  $[4, \infty)$     (d)  $(4, \infty)$

10. What is the domain for

$$f(x) = \frac{\sqrt{x-4}}{x-5}?$$

- (a)  $[4, 5) \cup (5, \infty)$                                   (b)  $(-\infty, 4) \cup (4, \infty)$   
 (c)  $[4, \infty)$     (d)  $(4, \infty)$

**SOLUTIONS**

1. A      2. B      3. D      4. A      5. C  
 6. B      7. D      8. A      9. D      10. A



## CHAPTER

# Functions and Their Graphs

The graph of a function can give us a great deal of information about the function. In this chapter we will use the graph of a function to evaluate the function, find the  $x$ - and  $y$ -intercepts (if any), the domain and range, and determine where the function is increasing or decreasing (an important idea in calculus).

To say that  $f(-3) = 1$  means that the point  $(-3, 1)$  is on the graph of  $f(x)$ . If  $(5, 4)$  is a point on the graph of  $f(x)$ , then  $f(5) = 4$ .

### EXAMPLE

- The graph in Figure 3.1 is the graph of  $f(x) = x^3 - x^2 - 4x + 4$ . Find  $f(-1)$ ,  $f(0)$ ,  $f(3)$ , and  $f(-2)$ .

The point  $(-1, 6)$  is on the graph means that  $f(-1) = 6$ .

The point  $(0, 4)$  is on the graph means that  $f(0) = 4$ .

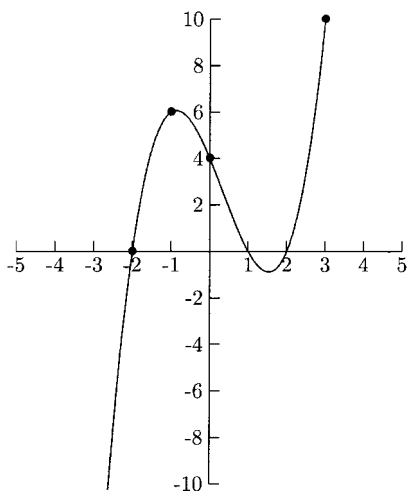

Fig. 3.1.

The point  $(3, 10)$  is on the graph means that  $f(3) = 10$ .

The point  $(-2, 0)$  is on the graph means that  $f(-2) = 0$ .

The graph also shows the *intercepts* of the graph. Remember that an  $x$ -intercept is a point where the graph touches the  $x$ -axis, and the  $y$ -intercept is a point where the graph touches the  $y$ -axis. We can tell that the  $y$ -intercept for the graph in Figure 3.1 is 4 (or  $(0, 4)$ ) and the  $x$ -intercepts are  $-2$ ,  $1$ , and  $2$  (or  $(-2, 0)$ ,  $(1, 0)$  and  $(2, 0)$ ).

An equation “gives  $y$  as a function of  $x$ ” means that for every  $x$ -value, there is a unique  $y$ -value. From this fact we can look at a graph of an equation to decide if the equation gives  $y$  as a function of  $x$ . If an  $x$ -value has more than one  $y$ -value in the equation, then there will be more than one point on the graph that has the same  $x$ -coordinate. A line through points that have the same  $x$ -coordinate is vertical. This is the idea behind the *Vertical Line Test*. The graph of an equation passes the Vertical Line Test if every vertical line touches the graph at one point or not at all. If so, then the equation is a function.

The graph of  $y^2 = x$  is shown in Figure 3.2. The vertical line  $x = 4$  touches the graph in two places,  $(4, 2)$  and  $(4, -2)$ , so  $y$  is not a function of  $x$  in the equation  $y^2 = x$ .

The domain of a function consists of all possible  $x$ -values. We can find the domain of a function by looking at its graph. The graph’s extension horizontally shows the function’s domain. The range of a function consists of all possible  $y$ -values. The graph’s vertical extension shows the function’s range.



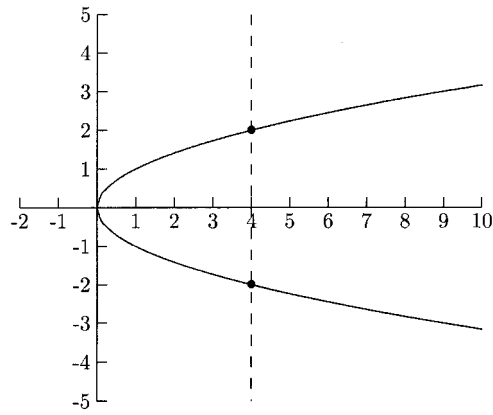

Fig. 3.2.

## EXAMPLES

Give the domain and range in interval notation.

•

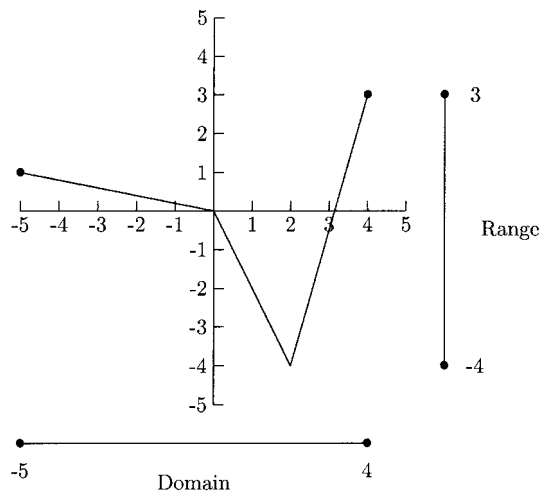

Fig. 3.3.

The graph extends horizontally from  $x = -5$  to  $x = 4$ . Because there are closed dots on these endpoints (instead of open dots),  $x = -5$  and  $x = 4$  are part of the domain, too. The domain is  $[-5, 4]$ . The graph extends vertically from  $y = -4$  to  $y = 3$ . The range is  $[-4, 3]$ .

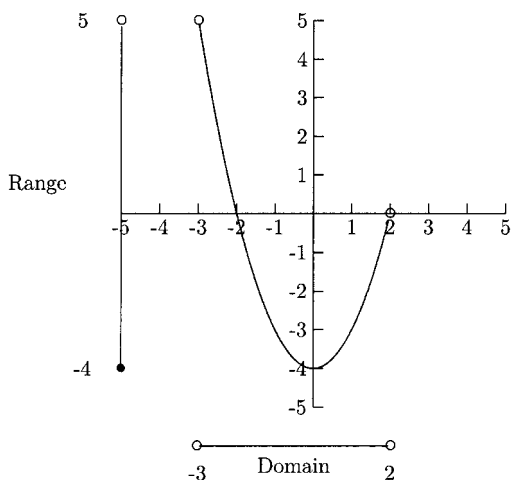

Fig. 3.4.

The graph extends horizontally from  $x = -3$  to  $x = 2$ . Because open dots are used on  $(-3, 5)$  and  $(2, 0)$ , these points are not on the graph, so  $x = -3$  and  $x = 2$  are not part of the domain. The domain is  $(-3, 2)$ . The graph extends vertically from  $y = -4$  and  $y = 5$ . The range is  $[-4, 5)$ . We need to use a bracket around  $-4$  because  $(0, -4)$  is a point on the graph, and a parenthesis around  $5$  because the point  $(-3, 5)$  is not a point on the graph.

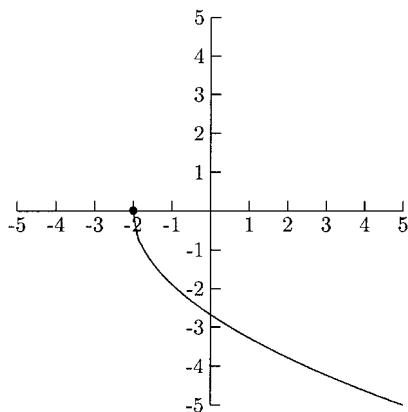

Fig. 3.5.

The graph extends horizontally from  $x = -2$  on the left and vertically from below  $y = 0$ . The domain is  $[-2, \infty)$ , and the range is  $(-\infty, 0]$ .

A function is increasing on an interval if moving toward the right in the interval means the graph is going up. A function is decreasing on an interval if moving

toward the right in the interval means the graph is going down. The function whose graph is in Figure 3.6 is increasing from  $x = -3$  to  $x = 0$  as well as to the right of  $x = 2$ . It is decreasing to the left of  $x = -3$  and between  $x = 0$  and  $x = 2$ . Using interval notation, we say the function is increasing on the intervals  $(-3, 0)$  and  $(2, \infty)$  and decreasing on the intervals  $(-\infty, -3)$  and  $(0, 2)$ . For reasons covered in calculus, parentheses are used for the interval notation.

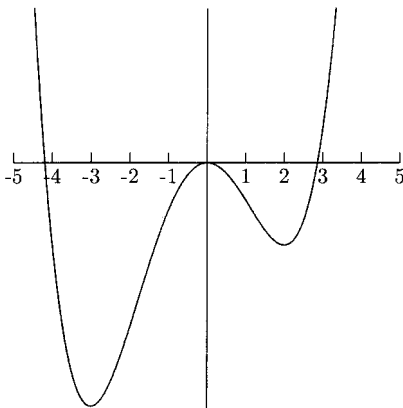

Fig. 3.6.

A function is constant on an interval if the  $y$ -values do not change. This part of the graph will be part of a horizontal line.

### EXAMPLES

Determine the intervals on which the functions are increasing, decreasing or constant.

- 

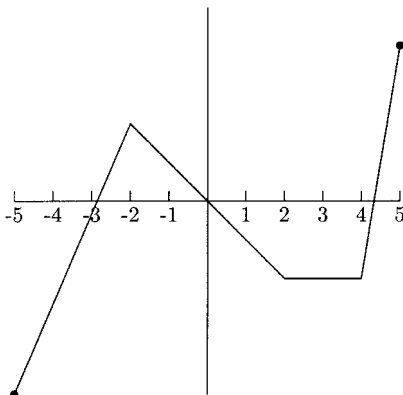

Fig. 3.7.

This function is increasing on  $(-5, -2)$  and  $(4, 5)$ . It is decreasing on  $(-2, 2)$  and constant on  $(2, 4)$ .

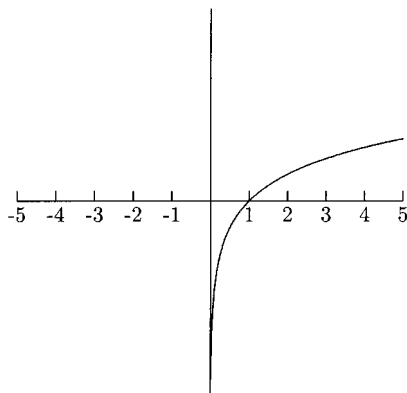

Fig. 3.8.

The function is increasing on all of its domain,  $(0, \infty)$ .

### PRACTICE

- Is the graph in Figure 3.9 the graph of a function?

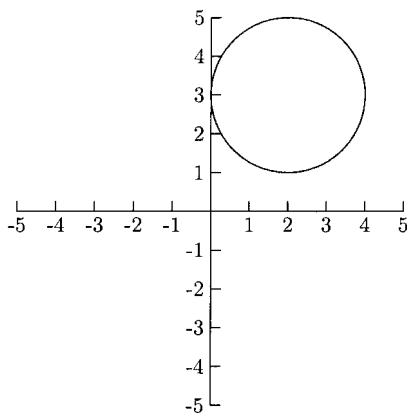

Fig. 3.9.

- Refer to the graph of  $f(x)$  in Figure 3.10.
  - What is  $f(-3)$ ?
  - What is  $f(5)$ ?
  - What is the domain?

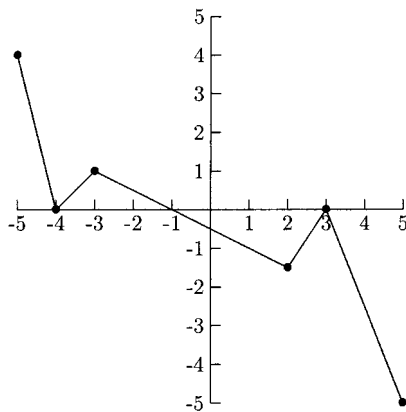

Fig. 3.10.

- (d) What is the range?
  - (e) What are the  $x$ -intercepts?
  - (f) What is the  $y$ -intercept?
  - (g) What is/are the increasing interval(s)?
  - (h) What is/are the decreasing interval(s)?
3. Refer to the graph of  $f(x)$  in Figure 3.11.

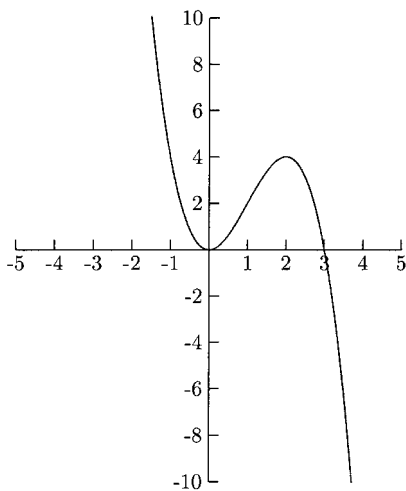

Fig. 3.11.

- (a) What is  $f(2)$ ?  $f(1)$ ?
- (b) What are the  $x$ -intercepts? What is the  $y$ -intercept?

- (c) What is the domain? Range?
- (d) What is the increasing interval? What are the decreasing intervals?

## SOLUTIONS

1. No. The graph fails the Vertical Line Test.
2. (a)  $f(-3) = 1$  because  $(-3, 1)$  is a point on the graph.  
(b)  $f(5) = -5$  because  $(5, -5)$  is a point on the graph.  
(c) The domain is  $[-5, 5]$ .  
(d) The range is  $[-5, 4]$ .  
(e) The  $x$ -intercepts are  $-4$ ,  $-1$ , and  $3$ .  
(f) The  $y$ -intercept is  $-\frac{1}{2}$ .  
(g) The increasing intervals are  $(-4, -3)$  and  $(2, 3)$ .  
(h) The decreasing intervals are  $(-5, -4)$ ,  $(-3, 2)$  and  $(3, 5)$ .
3. (a)  $f(2) = 4$  because  $(2, 4)$  is a point on the graph.  $f(1) = 2$  because  $(1, 2)$  is a point on the graph.  
(b) The  $x$ -intercepts are  $0$  and  $3$ . The  $y$ -intercept is  $0$ .  
(c) The domain and range are each all real numbers,  $(-\infty, \infty)$ .  
(d) The increasing interval is  $(0, 2)$ , and the decreasing intervals are  $(-\infty, 0)$  and  $(2, \infty)$ .

Graphs are useful tools to present a lot of information in a small space. Being able to read a graph and draw conclusions from it are important in many subjects in addition to mathematics. In the example below, we will practice drawing conclusions based on information given in the graph in Figure 3.12. This graph shows the daily balance of a checking account for about two weeks. No more than one transaction (a deposit or a check written) is made in one day. For example, the balance at the end of the second day is \$350 and \$300 at the end of the third day, so a \$50 check was written on the third day.

1. On what day was a check for \$200 written?  
On the 12th day when the balance dropped from \$150 to  $-\$50$ .
2. What is the largest deposit?  
The largest increase was \$200, on the 8th day when the balance increased from \$200 to \$400.
3. What is the largest check written?  
The largest check was written on the tenth day when the balance dropped from \$400 to \$150.

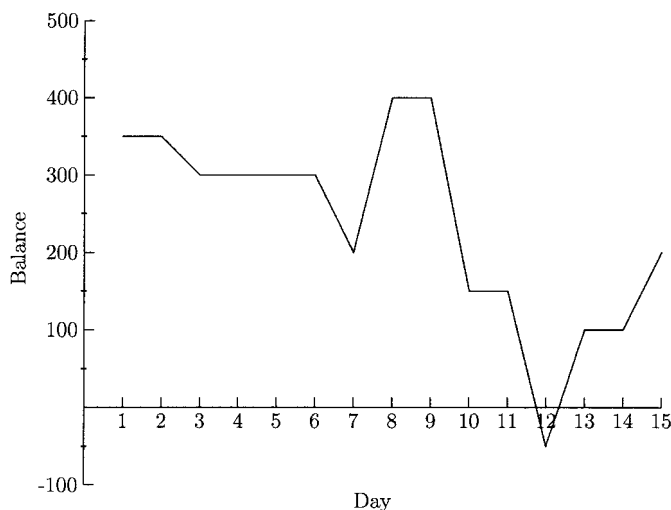

Fig. 3.12.

4. When was the account overdrawn?  
The balance was negative on the 12th day.

## Average Rate of Change

Calculus deals with the rate of change. A familiar example of a rate of change is speed (or more accurately, velocity). Velocity is the rate of change of distance per unit of time. A car traveling in city traffic will generally have a lower rate of change of distance per hour than a car traveling on an interstate freeway. A glass of water placed in a refrigerator will have a lower rate of temperature change than a glass of water placed in a freezer. In calculus, you will study instantaneous rates of change of functions at different values of  $x$ . We will study the *average rate of change* in this book. As you will see in the following examples, the average rate of change can hide a lot of variation.

## EXAMPLES

- Suppose \$1000 was invested in company stock of some manufacturing company. The value of the investment at the beginning of each year is given in Table 3.1.
  1. How much did the stock increase per year on average from the beginning of Year 3 to the beginning of Year 6?

Table 3.1

Year	Value (in dollars)	Change from the previous year
1	1000	New investment of \$1000
2	1205	Gain of \$205
3	1162	Loss of \$43
4	1025	Loss of \$137
5	1190	Gain of \$165
6	1252	Gain of \$62
7	1434	Gain of \$182
8	1621	Gain of \$187
9	2015	Gain of \$394
10	2845	Gain of \$830

For this three-year period the investment increased in value from \$1162 to \$1252. The average rate of change is

$$\frac{1252 - 1162}{6 - 3} = \frac{90}{3} = 30 \text{ per year.}$$

2. What was the average annual loss from the beginning of Year 2 to the beginning of Year 5?

The average rate of change during this three-year period is

$$\frac{1190 - 1205}{5 - 2} = \frac{-15}{3} = -5 \text{ per year.}$$

The negative symbol means that this change is a loss, not a gain.

3. What was the average annual increase over the full period?

The average increase in the investment over the full nine years is

$$\frac{2845 - 1000}{10 - 1} = \frac{1845}{9} = 205 \text{ per year.}$$

- Find the average rate of change between  $(-3, 9)$  and  $(-1, 3)$  and between  $(1, 1.5)$  and  $(3, 1.125)$  for the function whose graph is given in Figure 3.13.

The average rate of change of a function between two points on the graph is the slope of the line containing the two points. For the points  $(-3, 9)$  and  $(-1, 3)$ ,  $x_1 = -3$ ,  $y_1 = 9$  and  $x_2 = -1$  and  $y_2 = 3$ .

$$\text{Average rate of change} = \frac{y_2 - y_1}{x_2 - x_1} = \frac{3 - 9}{-1 - (-3)} = \frac{-6}{2} = \frac{-3}{1} = -3$$



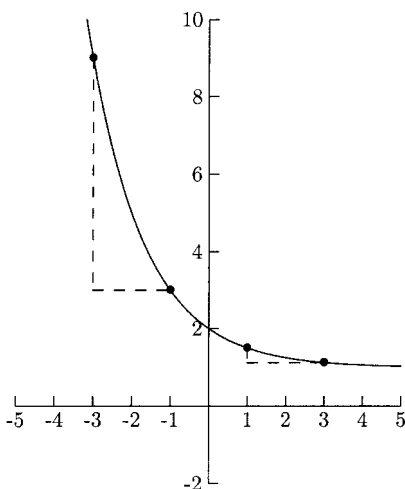

Fig. 3.13.

Between  $x = -3$  and  $x = -1$ , the  $y$ -values of this function *decrease* by 3 as  $x$  increases by 1, on average.

For the points  $(1, 1.5)$  and  $(3, 1.125)$   $x_1 = 1$ ,  $y_1 = 1.5$  and  $x_2 = 3$ ,  $y_2 = 1.125$ .

$$\text{Average rate of change} = \frac{y_2 - y_1}{x_2 - x_1} = \frac{1.125 - 1.5}{3 - 1} = \frac{-0.375}{2} = -0.1875$$

Between  $x = 1$  and  $x = 3$ , the  $y$ -values of this function decrease on average by 0.1875 as  $x$  increases by 1.

- Find the average rate of change of  $f(x) = -3x^2 + 10$  between  $x = -1$  and  $x = 2$ .

Once we have found the  $y$ -values by putting these  $x$ -values into the function, we will find the slope of the line containing these two points.

$$y_1 = f(x_1) = f(-1) = -3(-1)^2 + 10 = 7$$

$$y_2 = f(x_2) = f(2) = -3(2)^2 + 10 = -2$$

$$\text{Average rate of change} = \frac{y_2 - y_1}{x_2 - x_1} = \frac{-2 - 7}{2 - (-1)} = \frac{-9}{3} = \frac{-3}{1} = -3$$

Between  $x = -1$  and  $x = 2$ , this function decreases on average by 3 as  $x$  increases by 1.

**PRACTICE**

1. A sales representative's pay is based on his sales. Table 3.2 shows his salary during one year.

**Table 3.2**

Month	Pay
January (1)	2100
February (2)	2000
March (3)	2400
April (4)	2700
May (5)	2500
June (6)	3000
July (7)	3500
August (8)	3600
September (9)	2500
October (10)	2000
November (11)	2000
December (12)	2100

How much did his monthly pay change on average between January and July? Between July and December? Between October and December?

2. Find the average rate of change between the indicated points of the function whose graph is given in Figure 3.14.

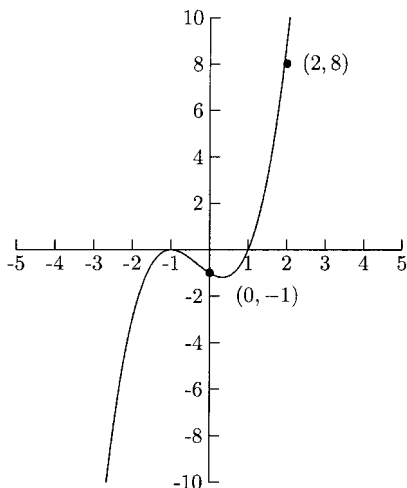

**Fig. 3.14.**

- Find the average rate of change for  $f(x) = 2 - x^3$  between  $x = -2$  and  $x = 1$ .
- Find the average rate of change for  $f(x) = 6x - 3$  between  $x = -5$  and  $x = 3$  and between  $x = 0$  and  $x = 8$ .

## SOLUTIONS

- The average monthly increase between January and July is the slope of the line containing the points  $(1, 2100)$  and  $(7, 3500)$ .

$$\frac{3500 - 2100}{7 - 1} \approx 233$$

The average monthly decrease between July and December is the slope of the line containing the points  $(7, 3500)$  and  $(12, 2100)$ .

$$\frac{2100 - 3500}{12 - 7} = -280$$

The average monthly increase from October to December is the slope of the line containing the points  $(10, 2000)$  and  $(12, 2100)$ .

$$\frac{2100 - 2000}{12 - 10} = 50$$

- $x_1 = 0$ ,  $y_1 = -1$  and  $x_2 = 2$ ,  $y_2 = 8$

$$\text{Average rate of change} = \frac{8 - (-1)}{2 - 0} = \frac{9}{2}$$

- 

$$y_1 = f(x_1) = f(-2) = 2 - (-2)^3 = 10$$

$$y_2 = f(x_2) = f(1) = 2 - (1)^3 = 1$$

$$\text{Average rate of change} = \frac{1 - 10}{1 - (-2)} = -3$$

- For  $x_1 = -5$  and  $x_2 = 3$ —

$$y_1 = f(x_1) = f(-5) = 6(-5) - 3 = -33$$

$$y_2 = f(x_2) = f(3) = 6(3) - 3 = 15$$

$$\text{Average rate of change} = \frac{15 - (-33)}{3 - (-5)} = 6$$

For  $x_1 = 0$  and  $x_2 = 8$ —

$$y_1 = f(x_1) = f(0) = 6(0) - 3 = -3$$

$$y_2 = f(x_2) = f(8) = 6(8) - 3 = 45$$

$$\text{Average rate of change} = \frac{45 - (-3)}{8 - 0} = 6$$

The average rate of change between *any* two points on a linear function is the slope.

Newton's Quotient gives the average rate of change of  $f(x)$  between  $x_1 = a$  and  $x_2 = a + h$ .

$$y_1 = f(x_1) = f(a)$$

$$y_2 = f(x_2) = f(a + h)$$

$$\text{Average rate of change} = \frac{y_2 - y_1}{x_2 - x_1} = \frac{f(a + h) - f(a)}{a + h - a} = \frac{f(a + h) - f(a)}{a}$$

## Even and Odd Functions

A graph is *symmetric* if one half looks like the other half. We might also say that one half of the graph is a reflection of the other.

When a graph has symmetry, we usually say that it is symmetric with respect to a line or a point. The graph in Figure 3.15 is symmetric with respect to the  $x$ -axis because the half of the graph above the  $x$ -axis is a reflection of the half below the  $x$ -axis. The graph in Figure 3.16 is symmetric with respect to the  $y$ -axis.

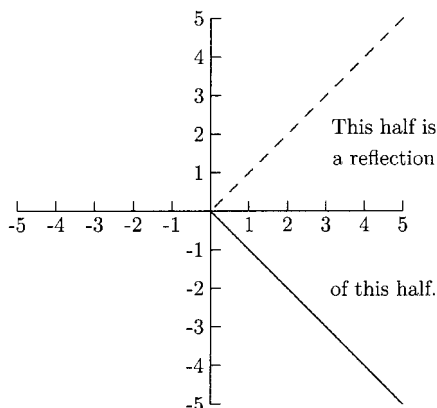

**Fig. 3.15.**

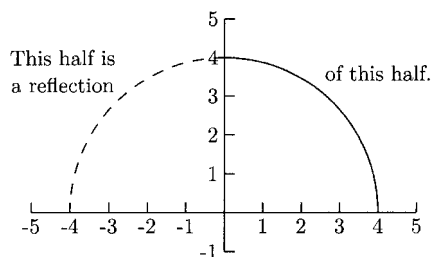

Fig. 3.16.

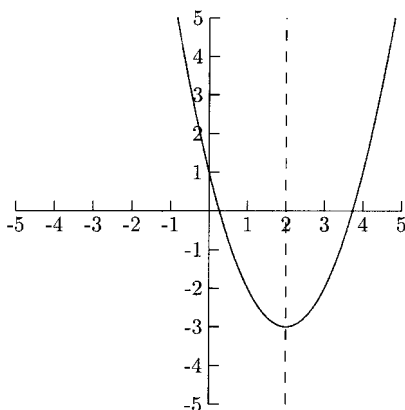

Fig. 3.17.

The graph in Figure 3.17 is symmetric with respect to the vertical line  $x = 2$ .

One type of symmetry that is a little harder to see is *origin symmetry*. A graph has origin symmetry if folding the graph along the  $x$ -axis then again along the  $y$ -axis would have one part of the graph coincide with the other part. The graphs in Figures 3.18 and 3.19 have origin symmetry.

Knowing in advance whether or not the graph of a function is symmetric can make sketching the graph less work. We can use algebra to decide if the graph of a function has  $y$ -axis symmetry or origin symmetry. Except for the function  $f(x) = 0$ , the graph of a function will not have  $x$ -axis symmetry because  $x$ -axis symmetry would cause a graph to fail the Vertical Line Test.

For the graph of a function to be symmetric with respect to the  $y$ -axis, a point on the left side of the  $y$ -axis will have a mirror image on the right side of the graph.

The graph of a function with  $y$ -axis symmetry has the property that  $(x, y)$  is on the graph means that  $(-x, y)$  is also on the graph. The functional notation for this idea is  $f(x) = f(-x)$ . “ $f(x) = f(-x)$ ” says that the  $y$  value for  $x$  ( $f(x)$ )

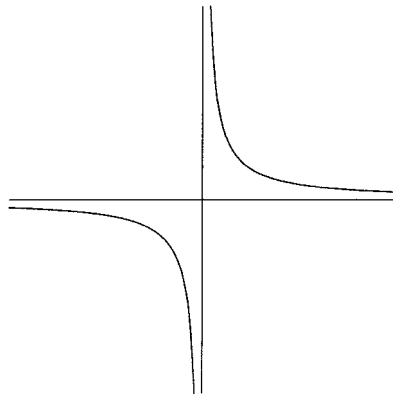

Fig. 3.18.

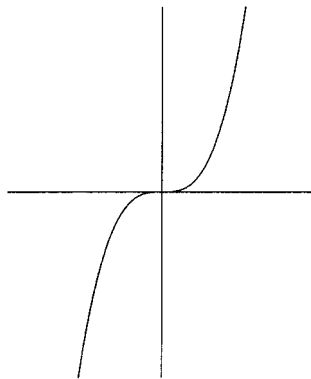

Fig. 3.19.

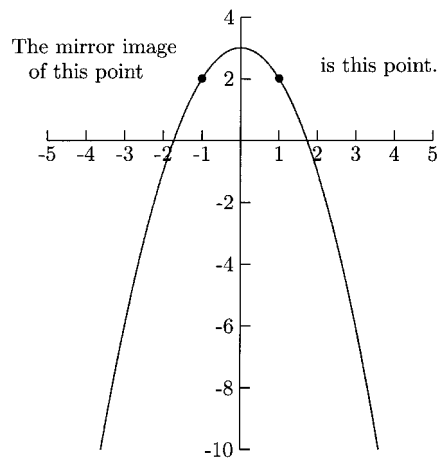

Fig. 3.20.

is the same as the  $y$ -value for  $-x$  ( $f(-x)$ ). If evaluating a function at  $-x$  does not change the equation, then its graph will have  $y$ -axis symmetry. Such functions are called *even functions*.

For a function whose graph is symmetric with respect to the origin, the mirror image of  $(x, y)$  is  $(-x, -y)$ .

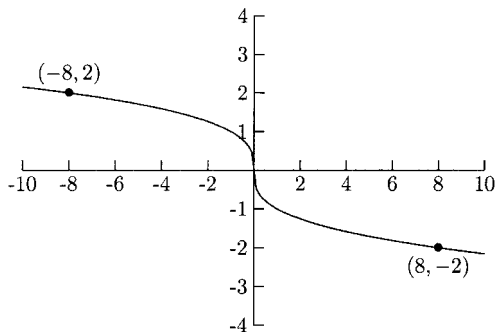

Fig. 3.21.

The functional notation for this idea is  $f(-x) = -f(x)$ . “ $f(-x) = -f(x)$ ” says that the  $y$ -value for  $-x$  ( $f(-x)$ ) is the opposite of the  $y$ -value for  $x$  ( $-f(x)$ ). If evaluating a function at  $-x$  changes the equation to its negative, then the graph of the function will be symmetric with respect to the origin. These functions are called *odd functions*.

In order to work the following problems, we will need the following facts.

$$a(-x)^{\text{even power}} = ax^{\text{even power}} \quad \text{and} \quad a(-x)^{\text{odd power}} = -ax^{\text{odd power}}$$

## EXAMPLES

Determine if the given function is even (its graph is symmetric with respect to the  $y$ -axis), odd (its graph is symmetric with respect to the origin), or neither.

- $f(x) = x^2 - 2$   
Does evaluating  $f(x)$  at  $-x$  change the function? If so, is  $f(-x) = -(x^2 - 2) = -f(x)$ ?

$$f(-x) = (-x)^2 - 2 = x^2 - 2$$

Evaluating  $f(x)$  at  $-x$  does not change the function, so the function is even.

- $f(x) = x^3 + 5x$

Does evaluating  $f(x)$  at  $-x$  change the function? If so, is  $f(-x) = -(x^3 + 5x) = -f(x)$ ?

$$f(-x) = (-x)^3 + 5(-x) = -x^3 - 5x = -(x^3 + 5x) = -f(x)$$

Evaluating  $f(x)$  at  $-x$  gives us  $-f(x)$ , so the function is odd.

- $f(x) = \frac{x}{x+1}$

Does evaluating  $f(x)$  at  $-x$  change the function? If so, is  $f(-x) = -\frac{x}{x+1} = -f(x)$ ?

$$f(-x) = \frac{-x}{-x+1}$$

Because  $f(-x)$  is not the same as  $f(x)$  nor the same as  $-f(x)$ , the function is neither even nor odd.

## PRACTICE

For 1–4, determine whether or not the graph has symmetry. If it does, determine the kind of symmetry it has. For 5–8, determine if the functions are even, odd, or neither.

1.

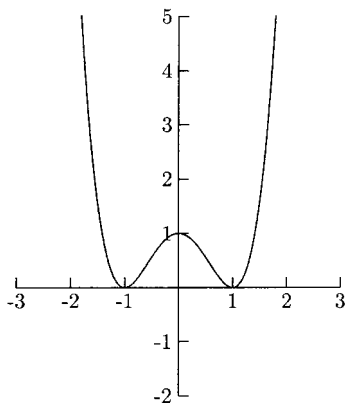

Fig. 3.22.



2.

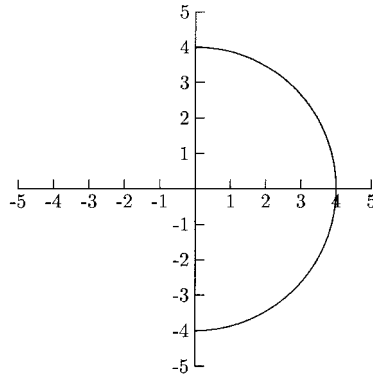

Fig. 3.23.

3.

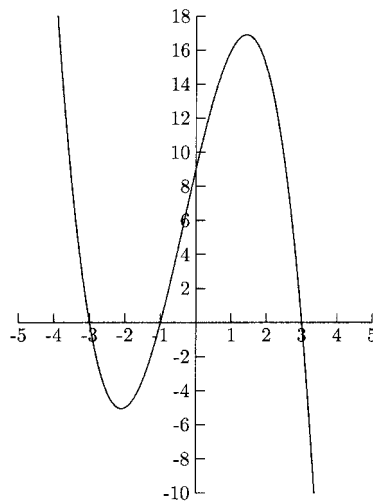

Fig. 3.24.

4.

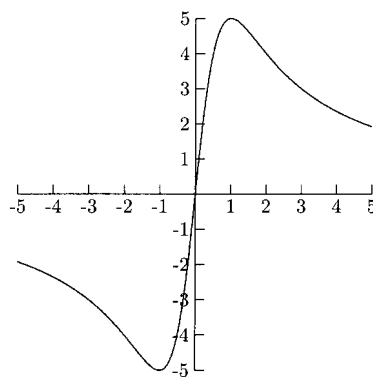

Fig. 3.25.

5.  $f(x) = x^3 + 6$
6.  $f(x) = 3x^2 - 2$
7.  $f(x) = \frac{x^2 - 3}{x^3 + 2x}$
8.  $g(x) = \sqrt[3]{x}$

### SOLUTIONS

1. This graph has  $y$ -axis symmetry.
2. This graph has  $x$ -axis symmetry.
3. This graph does not have symmetry.
4. This graph has origin symmetry.

$$5. f(-x) = (-x)^3 + 6 = -x^3 + 6$$

$f(-x) \neq f(x)$  and  $f(-x) \neq -f(x)$ , making  $f(x)$  neither even nor odd.

$$6. f(-x) = 3(-x)^2 - 2 = 3x^2 - 2$$

$f(-x) = f(x)$ , making  $f(x)$  even.

$$7. f(-x) = \frac{(-x)^2 - 3}{(-x)^3 + 2(-x)} = \frac{x^2 - 3}{-x^3 - 2x} = \frac{x^2 - 3}{-(x^3 + 2x)}$$

$$= -\frac{x^2 - 3}{x^3 + 2x} = -f(x)$$

$f(-x) = -f(x)$ , making  $f(x)$  odd.

$$8. g(-x) = \sqrt[3]{-x} = -\sqrt[3]{x} = -g(x)$$

$g(-x) = -g(x)$  making  $g(x)$  odd.

### CHAPTER 3 REVIEW

Problems 1–2 refer to the graph in Figure 3.26.

1. Find  $f(1)$ .
 

(a) -1	(b) -2	(c) 1	(d) 2
--------	--------	-------	-------

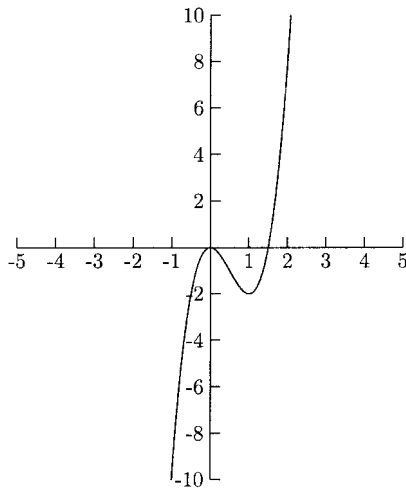

Fig. 3.26.

2. Where is the function decreasing?  
 (a)  $(-\infty, 0) \cup (1, \infty)$     (b)  $(0, -2)$     (c)  $(0, 1)$     (d)  $(1, \infty)$
- Problems 3–6 refer to the graph of  $f(x)$  in Figure 3.27.

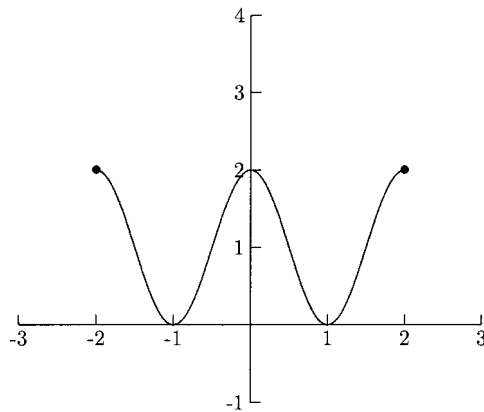

Fig. 3.27.

3. What is the domain?  
 (a)  $[0, 2]$     (b)  $[2, 0]$     (c)  $[-2, 2]$     (d)  $[-2, 0]$
4. What is the range?  
 (a)  $[0, 2]$     (b)  $[2, 0]$     (c)  $[-2, 2]$     (d)  $[-2, 0]$

5. What is the average rate of change of the function between  $x = -2$  and  $x = 1$ ?
- (a)  $-\frac{1}{2}$       (b)  $-\frac{2}{3}$       (c)  $-\frac{3}{4}$       (d)  $-1$
6. Is the graph in Figure 3.27 symmetric?
- (a) Yes, with respect to the  $x$ -axis. (c) Yes, with respect to the origin.  
 (b) Yes, with respect to the  $y$ -axis. (d) No.
7. Find the average rate of change for  $f(x) = \frac{1}{x+1}$  between  $x = 0$  and  $x = 2$ .
- (a)  $-3$       (b)  $-\frac{1}{3}$       (c)  $3$       (d)  $\frac{1}{3}$
8. Is the function  $f(x) = 3x^2 + 5$  even, odd, or neither?
- (a) Even  
 (b) Odd  
 (c) Neither  
 (d) Cannot be determined without the graph
9. Is the function  $f(x) = 3x^3 + 5$  even, odd, or neither?
- (a) Even  
 (b) Odd  
 (c) Neither  
 (d) Cannot be determined without the graph
10. Is the function  $f(x) = 4x^2/x^3 + x$  even, odd, or neither?
- (a) Even  
 (b) Odd  
 (c) Neither  
 (d) Cannot be determined without the graph

## SOLUTIONS

1. B      2. C      3. C      4. A      5. B  
 6. B      7. B      8. A      9. C      10. B



## CHAPTER

# Combinations of Functions and Inverse Functions

Most of the functions studied in calculus are some combination of only a few families of functions, most of the combinations are arithmetic. We can add two functions,  $f + g(x)$ , subtract them,  $f - g(x)$ , multiply them,  $fg(x)$ , and divide them  $\frac{f}{g}(x)$ . The domain of  $f + g(x)$ ,  $f - g(x)$ , and  $fg(x)$ , is the intersection of the domain of  $f(x)$  and  $g(x)$ . In other words, their domain is where the domain of  $f(x)$  overlaps the domain of  $g(x)$ . The domain of  $\frac{f}{g}(x)$  is the same, except we need to remove any  $x$  that makes  $g(x) = 0$ .

XI

## EXAMPLES

Find  $f + g(x)$ ,  $f - g(x)$ ,  $fg(x)$ , and  $\frac{f}{g}(x)$  and their domain.

- $f(x) = x^2 - 2x + 5$  and  $g(x) = 6x - 10$

$$f + g(x) = f(x) + g(x) = (x^2 - 2x + 5) + (6x - 10) = x^2 + 4x - 5$$

$$f - g(x) = f(x) - g(x) = (x^2 - 2x + 5) - (6x - 10) = x^2 - 8x + 15$$

$$\begin{aligned} fg(x) &= f(x)g(x) = (x^2 - 2x + 5)(6x - 10) = 6x^3 - 10x^2 - 12x^2 \\ &\quad + 20x + 30x - 50 \\ &= 6x^3 - 22x^2 + 50x - 50 \end{aligned}$$

$$\frac{f}{g}(x) = \frac{f(x)}{g(x)} = \frac{x^2 - 2x + 5}{6x - 10}$$

The domain of  $f + g(x)$ ,  $f - g(x)$ , and  $fg(x)$  is  $(-\infty, \infty)$ . The domain of  $\frac{f}{g}(x)$  is  $x \neq \frac{5}{3}$  (from  $6x - 10 = 0$ ), or  $(-\infty, \frac{5}{3}) \cup (\frac{5}{3}, \infty)$ .

- $f(x) = x - 3$  and  $g(x) = \sqrt{x + 2}$

$$f + g(x) = x - 3 + \sqrt{x + 2}$$

$$f - g(x) = x - 3 - \sqrt{x + 2}$$

$$fg(x) = (x - 3)\sqrt{x + 2}$$

$$\frac{f}{g}(x) = \frac{x - 3}{\sqrt{x + 2}}$$

The domain for  $f + g(x)$ ,  $f - g(x)$ , and  $fg(x)$  is  $[-2, \infty)$  (from  $x + 2 \geq 0$ ).

The domain for  $\frac{f}{g}(x)$  is  $(-2, \infty)$  because we need  $\sqrt{x + 2} \neq 0$ .

An important combination of two functions is *function composition*. This involves evaluating one function at the other. The notation for composing  $f$  with  $g$  is  $f \circ g(x)$ . By definition,  $f \circ g(x) = f(g(x))$ , this means that we substitute  $g(x)$  for  $x$  in  $f(x)$ .

## EXAMPLES

Find  $f \circ g(x)$  and  $g \circ f(x)$ .

- $f(x) = x^2 + 1$  and  $g(x) = 3x + 2$

$$\begin{aligned} f \circ g(x) &= f(g(x)) \\ &= f(3x + 2) && \text{Replace } g(x) \text{ with } 3x + 2. \\ &= (3x + 2)^2 + 1 && \text{Substitute } 3x + 2 \text{ for } x \text{ in } f(x). \\ &= (3x + 2)(3x + 2) + 1 = 9x^2 + 12x + 5 \end{aligned}$$

$$\begin{aligned} g \circ f(x) &= g(f(x)) \\ &= g(x^2 + 1) && \text{Replace } f(x) \text{ with } x^2 + 1. \\ &= 3(x^2 + 1) + 2 && \text{Substitute } x^2 + 1 \text{ for } x \text{ in } g(x). \\ &= 3x^2 + 3 + 2 = 3x^2 + 5 \end{aligned}$$

- $f(x) = \sqrt{5x - 2}$  and  $g(x) = x^2$

$$\begin{aligned} f \circ g(x) &= f(g(x)) \\ &= f(x^2) && \text{Replace } g(x) \text{ with } x^2. \\ &= \sqrt{5x^2 - 2} && \text{Substitute } x^2 \text{ for } x \text{ in } f(x). \end{aligned}$$

$$\begin{aligned} g \circ f(x) &= g(f(x)) \\ &= g(\sqrt{5x - 2}) && \text{Replace } f(x) \text{ with } \sqrt{5x - 2}. \\ &= (\sqrt{5x - 2})^2 && \text{Substitute } \sqrt{5x - 2} \text{ for } x \text{ in } g(x). \\ &= 5x - 2 \end{aligned}$$

- $f(x) = \frac{1}{x + 1}$  and  $g(x) = \frac{2x - 1}{x + 3}$

$$\begin{aligned} f \circ g(x) &= f(g(x)) = f\left(\frac{2x - 1}{x + 3}\right) \\ &= \frac{1}{\frac{2x - 1}{x + 3} + 1} = \frac{1}{\frac{2x - 1}{x + 3} + 1 \cdot \frac{x + 3}{x + 3}} \\ &= \frac{1}{\frac{2x - 1 + x + 3}{x + 3}} = \frac{1}{\frac{3x + 2}{x + 3}} \end{aligned}$$

$$\begin{aligned}
 &= 1 \div \frac{3x+2}{x+3} = 1 \cdot \frac{x+3}{3x+2} \\
 &= \frac{x+3}{3x+2}
 \end{aligned}$$

$$\begin{aligned}
 g \circ f(x) &= g(f(x)) = g\left(\frac{1}{x+1}\right) \\
 &= \frac{2\left(\frac{1}{x+1}\right) - 1}{\frac{1}{x+1} + 3} = \frac{\frac{2}{x+1} - 1 \cdot \frac{x+1}{x+1}}{\frac{1}{x+1} + 3 \cdot \frac{x+1}{x+1}} \\
 &= \frac{\frac{2-(x+1)}{x+1}}{\frac{1+3(x+1)}{x+1}} = \frac{\frac{-x+1}{x+1}}{\frac{3x+4}{x+1}} \\
 &= \frac{-x+1}{x+1} \div \frac{3x+4}{x+1} = \frac{-x+1}{x+1} \cdot \frac{x+1}{3x+4} \\
 &= \frac{-x+1}{3x+4}
 \end{aligned}$$

At times, we only need to find  $f \circ g(x)$  for a particular value of  $x$ . The  $y$ -value for  $g(x)$  becomes the  $x$ -value for  $f(x)$ .

### EXAMPLE

- Find  $f \circ g(-1)$ ,  $f \circ g(0)$ , and  $g \circ f(1)$  for  $f(x) = 4x + 3$  and  $g(x) = 2 - x^2$ .

$$\begin{array}{ll}
 f \circ g(-1) = f(g(-1)) & \text{Compute } g(-1). \\
 = f(1) & g(-1) = 2 - (-1)^2 = 1 \\
 = 4(1) + 3 = 7 & \text{Evaluate } f(x) \text{ at } x = 1.
 \end{array}$$

$$\begin{array}{ll}
 f \circ g(0) = f(g(0)) & \text{Compute } g(0). \\
 = f(2) & g(0) = 2 - 0^2 = 2 \\
 = 4(2) + 3 = 11 & \text{Evaluate } f(x) \text{ at } x = 2.
 \end{array}$$



$$\begin{aligned}
 g \circ f(1) &= g(f(1)) && \text{Compute } f(1). \\
 &= g(7) && f(1) = 4(1) + 3 = 7 \\
 &= 2 - 7^2 = -47 && \text{Evaluate } g(x) \text{ at } x = 7.
 \end{aligned}$$

We can compose two functions at a single  $x$ -value by looking at the graphs of the individual functions. To find  $f \circ g(a)$ , we will look at the graph of  $g(x)$  to find the point whose  $x$ -coordinate is  $a$ . The  $y$ -coordinate of this point will be  $g(a)$ . Then we will look at the graph of  $f(x)$  to find the point whose  $x$ -coordinate is  $g(a)$ . The  $y$ -coordinate of this point will be  $f(g(a)) = f \circ g(a)$ .

### EXAMPLE

Refer to Figure 4.1. The solid graph is the graph of  $f(x)$ , and the dashed graph is the graph of  $g(x)$ .

- Find  $f \circ g(-1)$ ,  $f \circ g(3)$ ,  $f \circ g(5)$ , and  $g \circ f(0)$ .

$$\begin{aligned}
 f \circ g(-1) &= f(g(-1)) && \text{Look for } x = -1 \text{ on } g(x). \\
 &= f(-2) && (-1, -2) \text{ is on the graph of } g(x), \text{ so } g(-1) = -2. \\
 &= 0 && (-2, 0) \text{ is on the graph of } f(x), \text{ so } f(-2) = 0.
 \end{aligned}$$

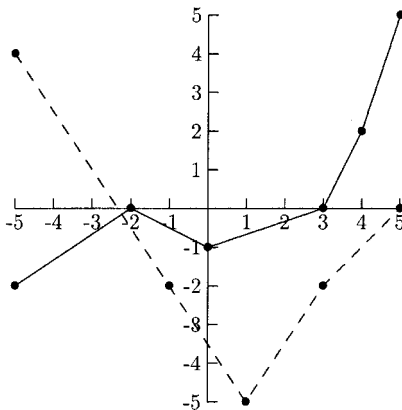

Fig. 4.1.

$$\begin{aligned}
 f \circ g(3) &= f(g(3)) && \text{Look for } x = 3 \text{ on } g(x). \\
 &= f(-2) && (3, -2) \text{ is on the graph of } g(x), \text{ so } g(3) = -2. \\
 &= 0 && (-2, 0) \text{ is on the graph of } f(x), \text{ so } f(-2) = 0.
 \end{aligned}$$

$$\begin{aligned}
 f \circ g(5) &= f(g(5)) && \text{Look for } x = 5 \text{ on } g(x). \\
 &= f(0) && (5, 0) \text{ is on the graph of } g(x), \text{ so } g(5) = 0. \\
 &= -1 && (0, -1) \text{ is on the graph of } f(x), \text{ so } f(0) = -1.
 \end{aligned}$$

$$\begin{aligned}
 g \circ f(0) &= g(f(0)) && \text{Look for } x = 0 \text{ on } f(x). \\
 &= g(-1) && (0, -1) \text{ is on the graph of } f(x), \text{ so } f(0) = -1. \\
 &= -2 && (-1, -2) \text{ is on the graph of } g(x), \text{ so } g(-1) = -2.
 \end{aligned}$$

Unfortunately, finding the domain for the composition of two functions is not straightforward. The definition for the domain of  $f \circ g(x)$  is the set of all real numbers  $x$  such that  $g(x)$  is in the domain of  $f(x)$ . When finding the domain for  $f \circ g(x)$ , begin with the domain with  $g(x)$ . Then remove any  $x$ -value whose  $y$ -value is not in the domain for  $f(x)$ . For example if  $f(x) = \frac{1}{x}g(x) = x + 3$ , the  $y$ -values for  $g(x)$  are  $x + 3$ . We need for  $x + 3$  to be nonzero for  $f \circ g(x) = \frac{1}{x+3}$ .

## EXAMPLES

Find the domain for  $f \circ g(x)$ .

- $f(x) = \frac{1}{x^2}$  and  $g(x) = \sqrt{2x - 6}$

The domain for  $g(x)$  is  $x \geq 3$  (from  $2x - 6 \geq 0$ ). Are there any  $x$ -values in  $[3, \infty)$  we cannot put into  $\frac{1}{(\sqrt{2x-6})^2}$ ? We cannot allow  $(\sqrt{2x - 6})^2$  to be zero, so we cannot allow  $x = 3$ . The domain for  $f \circ g(x)$  is  $(3, \infty)$ .

- $f(x) = \frac{1}{x}$  and  $g(x) = \frac{x-1}{x+1}$

The domain for  $g(x)$  is  $x \neq -1$ . Are there any  $x$ -values we need to remove from  $x \neq -1$ ? We need to find any real numbers that are not in the domain for

$$f \circ g(x) = f(g(x)) = f\left(\frac{x-1}{x+1}\right) = \frac{1}{\frac{x-1}{x+1}}$$

The denominator of this fraction is  $\frac{x-1}{x+1}$ , so we cannot allow  $\frac{x-1}{x+1}$  to be zero. A fraction equals zero only when the numerator is zero, so we cannot allow  $x - 1$  to be zero. We must remove  $x = 1$  from the domain of  $g(x)$ .

The domain of  $f \circ g(x)$  is  $x \neq -1, 1$ , or  $(-\infty, -1) \cup (-1, 1) \cup (1, \infty)$ . This function simplifies to  $f \circ g(x) = \frac{x+1}{x-1}$ , which hides the fact that we cannot let  $x = -1$ .

Any number of functions can be composed together. Functions can even be composed with themselves. When composing three or more functions together, we will work from the right to the left, performing one composition at a time.

## EXAMPLES

Find  $f \circ f(x)$  and  $f \circ g \circ h(x)$ .

- $f(x) = x^3$ ,  $g(x) = 2x - 5$ , and  $h(x) = x^2 + 1$ .

$$f \circ f(x) = f(f(x)) = f(x^3) = (x^3)^3 = x^9$$

For  $f \circ g \circ h(x)$ , we will begin with  $g \circ h(x) = g(h(x)) = g(x^2 + 1) = 2(x^2 + 1) - 5 = 2x^2 - 3$ . Now we need to evaluate  $f(x)$  at  $2x^2 - 3$ .

$$\begin{aligned} f \circ g \circ h(x) &= f(g(h(x))) \\ &= f(2x^2 - 3) = (2x^2 - 3)^3 \end{aligned}$$

- $f(x) = 3x + 7$ ,  $g(x) = |x - 2|$ , and  $h(x) = x^4 - 5$

$$f \circ f(x) = f(f(x)) = f(3x + 7) = 3(3x + 7) + 7 = 9x + 28$$

$$f \circ g \circ h(x) = f \circ g(h(x))$$

$$g(h(x)) = g(x^4 - 5) = |x^4 - 5 - 2| = |x^4 - 7|$$

$$\begin{aligned} f \circ g(h(x)) &= f(g(h(x))) = f(|x^4 - 7|) \\ &= 3|x^4 - 7| + 7 \end{aligned}$$

In order for calculus students to use some formulas, they need to recognize complicated functions as a combination of simpler functions. Sums, differences, products, and quotients are easy to see, but some compositions of functions are less obvious.

## EXAMPLES

Find functions  $f(x)$  and  $g(x)$  so that  $h(x) = f \circ g(x)$ .

- $h(x) = \sqrt{x + 16}$

Although there are many possibilities for  $f(x)$  and  $g(x)$ , there is usually one pair of functions that is obvious. Usually we want  $g(x)$  to be the computation that is done first and  $f(x)$ , the computation to be done last. Here, when computing the  $y$ -value for  $h(x)$ , we would calculate  $x + 16$ . This will be  $g(x)$ . The last calculation will be to take the square root. This will be  $f(x)$ . If we let  $f(x) = \sqrt{x}$  and  $g(x) = x + 16$ , we have  $f \circ g(x) = f(g(x)) = f(x + 16) = \sqrt{x + 16} = h(x)$ .

- $h(x) = \frac{2}{x^2+1}$

When computing a  $y$ -value for  $h(x)$ , we would first find  $x^2 + 1$ . This will be  $g(x)$ . This number will be the denominator of a fraction whose numerator is 2. This will be  $f(x)$ , a fraction whose numerator is 2 and whose denominator is  $x$ . If  $f(x) = \frac{2}{x}$  and  $g(x) = x^2 + 1$ ,

$$f \circ g(x) = f(g(x)) = f(x^2 + 1) = \frac{2}{x^2 + 1} = h(x).$$

## PRACTICE

1.  $f(x) = 3x^2 + x$  and  $g(x) = x - 4$ 
  - (a) Find  $f + g(x)$ ,  $f - g(x)$ ,  $fg(x)$ , and  $\frac{f}{g}(x)$ .
  - (b) What is the domain for  $\frac{f}{g}(x)$ ?
  - (c) Find  $f \circ g(x)$  and  $g \circ f(x)$ .
  - (d) What is the domain for  $f \circ g(x)$ ?
  - (e) Find  $f \circ g(1)$  and  $g \circ f(0)$ .
  - (f) Find  $f \circ f(x)$ .
2. Find  $f \circ g(x)$ ,  $g \circ f(x)$ , and the domain for  $f \circ g(x)$ .

$$f(x) = \frac{2x - 3}{x + 4} \quad \text{and} \quad g(x) = \frac{x}{x - 1}$$

3. Refer to the graphs in Figure 4.2. The solid graph is the graph of  $f(x)$ , and the dashed graph is the graph of  $g(x)$ . Find  $f \circ g(1)$ ,  $f \circ g(4)$ , and  $g \circ f(-2)$ .
4. Find  $f \circ g \circ h(x)$  for  $f(x) = \frac{1}{x+3}$ ,  $g(x) = 4x + 9$ , and  $h(x) = 5x^2 - 1$ .
5. Find functions  $f(x)$  and  $g(x)$  so that  $h(x) = f \circ g(x)$ , where  $h(x) = (x - 5)^3 + 2$ .

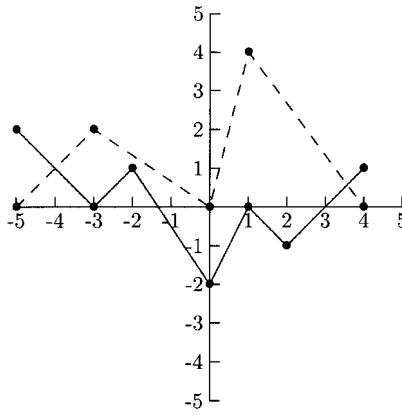

Fig. 4.2.

## SOLUTIONS

1. (a)

$$f + g(x) = (3x^2 + x) + (x - 4) = 3x^2 + 2x - 4$$

$$f - g(x) = (3x^2 + x) - (x - 4) = 3x^2 + 4$$

$$fg(x) = (3x^2 + x)(x - 4) = 3x^3 - 11x^2 - 4x$$

$$\frac{f}{g}(x) = \frac{3x^2 + x}{x - 4}$$

(b) The domain is  $x \neq 4$ , (from  $x - 4 = 0$ ), or  $(-\infty, 4) \cup (4, \infty)$ .

(c)

$$f \circ g(x) = f(g(x)) = f(x - 4) = 3(x - 4)^2 + (x - 4)$$

$$= 3(x - 4)(x - 4) + x - 4 = 3x^2 - 23x + 44$$

$$g \circ f(x) = g(f(x)) = g(3x^2 + x) = 3x^2 + x - 4$$

(d) The domain for  $g(x)$  is all real numbers. We can let  $x$  be any real number for  $f(x)$ , so we do not need to remove anything from the domain of  $g(x)$ . The domain of  $f \circ g(x)$  is all real numbers, or  $(-\infty, \infty)$ .

(e)

$$\begin{aligned}
 f \circ g(1) &= f(g(1)) \\
 &= f(-3) & g(1) &= 1 - 4 = -3 \\
 &= 24 & f(-3) &= 3(-3)^2 + (-3) = 24 \\
 g \circ f(0) &= g(f(0)) \\
 &= g(0) & f(0) &= 3(0)^2 + 0 = 0 \\
 &= -4 & g(0) &= 0 - 4 = -4
 \end{aligned}$$

(f)

$$\begin{aligned}
 f \circ f(x) &= f(f(x)) = f(3x^2 + x) = 3(3x^2 + x)^2 + (3x^2 + x) \\
 &= 3(3x^2 + x)(3x^2 + x) + 3x^2 + x = 27x^4 + 18x^3 + 6x^2 + x
 \end{aligned}$$

2.

$$\begin{aligned}
 f \circ g(x) &= f(g(x)) = f\left(\frac{x}{x-1}\right) \\
 &= \frac{2\left(\frac{x}{x-1}\right) - 3}{\frac{x}{x-1} + 4} = \frac{\frac{2x}{x-1} - 3 \cdot \frac{x-1}{x-1}}{\frac{x}{x-1} + 4 \cdot \frac{x-1}{x-1}} \\
 &= \frac{\frac{2x - 3(x-1)}{x-1}}{\frac{x + 4(x-1)}{x-1}} = \frac{\frac{-x + 3}{x-1}}{\frac{5x - 4}{x-1}} \\
 &= \frac{-x + 3}{x-1} \div \frac{5x - 4}{x-1} = \frac{-x + 3}{x-1} \cdot \frac{x-1}{5x-4} \\
 &= \frac{-x + 3}{5x - 4}
 \end{aligned}$$

$$\begin{aligned}
 g \circ f(x) &= g(f(x)) = g\left(\frac{2x-3}{x+4}\right) \\
 &= \frac{\frac{2x-3}{x+4}}{\frac{2x-3}{x+4} - 1} = \frac{\frac{2x-3}{x+4}}{\frac{2x-3}{x+4} - 1 \cdot \frac{x+4}{x+4}} \\
 &= \frac{\frac{2x-3}{x+4}}{\frac{2x-3-(x+4)}{x+4}} = \frac{\frac{2x-3}{x+4}}{\frac{x-7}{x+4}}
 \end{aligned}$$

$$\begin{aligned}
 &= \frac{2x-3}{x+4} \div \frac{x-7}{x+4} = \frac{2x-3}{x+4} \cdot \frac{x+4}{x-7} \\
 &= \frac{2x-3}{x-7}
 \end{aligned}$$

The domain of  $g(x)$  is  $x \neq 1$ . Now we need to see if there is anything we need to remove from  $x \neq 1$ . Before simplifying  $f \circ g(x)$ , we have

$$\frac{2\left(\frac{x}{x-1}\right) - 3}{\frac{x}{x-1} + 4}.$$

The denominator of this fraction cannot be zero, so we must have  $\frac{x}{x-1} + 4 \neq 0$ .

$$\begin{aligned}
 \frac{x}{x-1} + 4 &= 0 \\
 (x-1)\left(\frac{x}{x-1} + 4\right) &= (x-1)0 \\
 x + 4(x-1) &= 0 \\
 5x - 4 &= 0 \\
 x &= \frac{4}{5}
 \end{aligned}$$

The domain is  $x \neq 1, \frac{4}{5}$ , or  $(-\infty, \frac{4}{5}) \cup (\frac{4}{5}, 1) \cup (1, \infty)$ .

While it seems that  $x = -4$  might not be allowed in the domain of  $f \circ g(x)$ ,  $x = -4$  is in the domain.

$$\begin{aligned}
 f \circ g(-4) &= f(g(-4)) \\
 &= f\left(\frac{4}{5}\right) & g(-4) &= \frac{-4}{-4-1} = \frac{4}{5} \\
 &= -\frac{7}{24} & f\left(\frac{4}{5}\right) &= \frac{2(4/5) - 3}{4/5 + 4} = -\frac{7}{24}
 \end{aligned}$$

3.

$$\begin{aligned}
 f \circ g(1) &= f(g(1)) && \text{Look for } x = 1 \text{ on } g(x). \\
 &= f(4) && (1, 4) \text{ is on the graph of } g(x), \text{ so } g(1) = 4. \\
 &= 1 && (4, 1) \text{ is on the graph of } f(x), \text{ so } f(4) = 1.
 \end{aligned}$$

$$\begin{aligned}
 f \circ g(4) &= f(g(4)) && \text{Look for } x = 4 \text{ on } g(x). \\
 &= f(0) && (4, 0) \text{ is on the graph of } g(x), \text{ so } g(4) = 0. \\
 &= -2 && (0, -2) \text{ is on the graph of } f(x), \text{ so } f(0) = -2.
 \end{aligned}$$

$$\begin{aligned}
 g \circ f(-2) &= g(f(-2)) && \text{Look for } x = -2 \text{ on the graph of } f(x). \\
 &= g(1) && (-2, 1) \text{ is on the graph of } f(x), \text{ so } f(-2) = 1. \\
 &= 4 && (1, 4) \text{ is on the graph of } g(x), \text{ so } g(1) = 4.
 \end{aligned}$$

4.

$$\begin{aligned}
 f \circ g \circ h(x) &= f \circ g(h(x)) = f(g(h(x))) \\
 g(h(x)) &= g(5x^2 - 1) = 4(5x^2 - 1) + 9 = 20x^2 + 5 \\
 f(g(h(x))) &= f(20x^2 + 5) = \frac{1}{(20x^2 + 5) + 3} = \frac{1}{20x^2 + 8}
 \end{aligned}$$

5. One possibility is  $g(x) = x - 5$  and  $f(x) = x^3 + 2$ .

$$f \circ g(x) = f(g(x)) = f(x - 5) = (x - 5)^3 + 2 = h(x)$$

## Inverse Functions

In the same way operations on real numbers (like addition and multiplication) have identities and inverses, operations on functions can have identities and inverses. We can apply many operations on functions that we can apply to real numbers—adding, multiplying, raising to powers, etc. These operations can have identities and functions have inverses in the same way they do with real numbers. The additive identity for function addition is  $i(x) = 0$ . Each function has an additive inverse,  $-f(x)$  is the additive inverse for  $f(x)$ . The multiplicative identity for function multiplication is  $i(x) = 1$ , and the multiplicative inverse for  $f(x)$  is  $\frac{1}{f(x)}$ .

If we look at function composition as an operation on functions, then we can ask whether or not there is an identity for this operation and whether or not functions have inverses for this operation. There is an identity for this operation,  $i(x) = x$ . For any function  $f(x)$ ,  $f \circ i(x) = f(i(x)) = f(x)$ . Some functions have inverses. Later we will see which functions have inverses and how to find inverses. The notation for the inverse function of  $f(x)$  is  $f^{-1}(x)$ . This is different from  $(f(x))^{-1}$ , which is the multiplicative inverse for  $f(x)$ . For now, we will be given two functions that are said to be inverses of each other. We will use function composition to verify that they are.



## EXAMPLES

Verify that  $f(x)$  and  $g(x)$  are inverses.

- $f(x) = 2x + 5$  and  $g(x) = \frac{1}{2}x - \frac{5}{2}$   
We will show that  $f \circ g(x) = x$  and  $g \circ f(x) = x$ .

$$\begin{aligned} f \circ g(x) &= f(g(x)) = f\left(\frac{1}{2}x - \frac{5}{2}\right) \\ &= 2\left(\frac{1}{2}x - \frac{5}{2}\right) + 5 = x - 5 + 5 = x \end{aligned}$$

$$\begin{aligned} g \circ f(x) &= g(f(x)) = g(2x + 5) = \frac{1}{2}(2x + 5) - \frac{5}{2} \\ &= x + \frac{5}{2} - \frac{5}{2} = x \end{aligned}$$

- $f(x) = 5x^3 - 6$  and  $g(x) = \sqrt[3]{\frac{x+6}{5}}$

$$\begin{aligned} f \circ g(x) &= f(g(x)) = f\left(\sqrt[3]{\frac{x+6}{5}}\right) = 5\left(\sqrt[3]{\frac{x+6}{5}}\right)^3 - 6 \\ &= 5\left(\frac{x+6}{5}\right) - 6 = x + 6 - 6 = x \end{aligned}$$

$$\begin{aligned} g \circ f(x) &= g(f(x)) = g(5x^3 - 6) = \sqrt[3]{\frac{5x^3 - 6 + 6}{5}} \\ &= \sqrt[3]{\frac{5x^3}{5}} = \sqrt[3]{x^3} = x \end{aligned}$$

- $f(x) = \frac{2x-1}{x+4}$  and  $g(x) = \frac{4x+1}{2-x}$

$$\begin{aligned} f \circ g(x) &= f(g(x)) = f\left(\frac{4x+1}{2-x}\right) = \frac{2\left(\frac{4x+1}{2-x}\right) - 1}{\frac{4x+1}{2-x} + 4} \\ &= \frac{\frac{2(4x+1)}{2-x} - 1 \cdot \frac{2-x}{2-x}}{\frac{4x+1}{2-x} + 4 \cdot \frac{2-x}{2-x}} \end{aligned}$$

$$\begin{aligned}
 &= \frac{\frac{8x+2-(2-x)}{2-x}}{\frac{4x+1+4(2-x)}{2-x}} = \frac{9x}{2-x} \\
 &= \frac{9x}{2-x} \div \frac{9}{2-x} = \frac{9x}{2-x} \cdot \frac{2-x}{9} = x \\
 \\
 g \circ f(x) &= g(f(x)) = g\left(\frac{2x-1}{x+4}\right) = \frac{4\left(\frac{2x-1}{x+4}\right) + 1}{2 - \frac{2x-1}{x+4}} \\
 &= \frac{\frac{4(2x-1)}{x+4} + 1 \cdot \frac{x+4}{x+4}}{2 \cdot \frac{x+4}{x+4} - \frac{2x-1}{x+4}} = \frac{\frac{8x-4+x+4}{x+4}}{\frac{2(x+4)-(2x-1)}{x+4}} \\
 &= \frac{\frac{9x}{x+4}}{\frac{9}{x+4}} = \frac{9x}{x+4} \div \frac{9}{x+4} \\
 &= \frac{9x}{x+4} \cdot \frac{x+4}{9} = x
 \end{aligned}$$

If we think of a function as a collection of points on a graph, or ordered pairs, then the only thing that makes  $f(x)$  different from  $f^{-1}(x)$  is that their  $x$ -coordinates and  $y$ -coordinates are reversed. For example, if  $(3, -1)$  is a point on the graph of  $f(x)$ , then  $(-1, 3)$  is a point on the graph of  $f^{-1}(x)$ .

### EXAMPLE

The graph of a function  $f(x)$  is given in Figure 4.3. Use the graph of  $f(x)$  to sketch the graph of  $f^{-1}(x)$ .

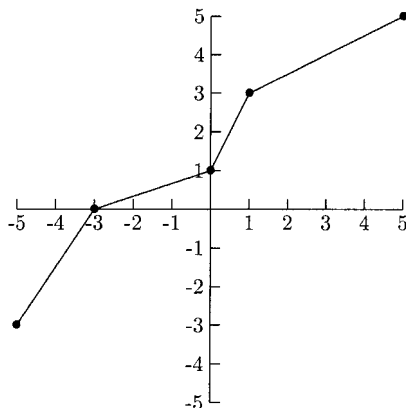

Fig. 4.3.

We will make a table of values for  $f(x)$  and switch the  $x$  and  $y$  columns for  $f^{-1}(x)$ .

Table 4.1

$x$	$y = f(x)$
-5	-3
-3	0
0	1
1	3
5	5

To get the table for  $f^{-1}(x)$ , we will switch the  $x$ - and  $y$ -values.

Table 4.2

$x$	$y = f^{-1}(x)$
-3	-5
0	-3
1	0
3	1
5	5

The solid graph is the graph of  $f(x)$ , and the dashed graph is the graph of  $f^{-1}(x)$ .

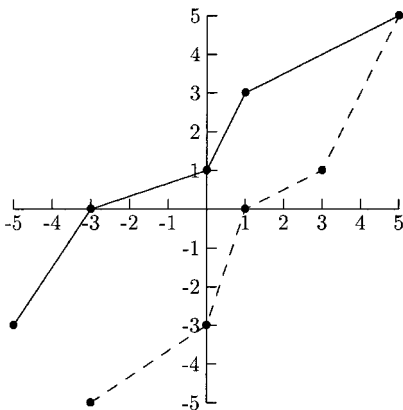

Fig. 4.4.

If  $f(x)$  is a function that has an inverse, then the graph of  $f^{-1}(x)$  is a reflection of the graph of  $f(x)$  across the line  $y = x$ .

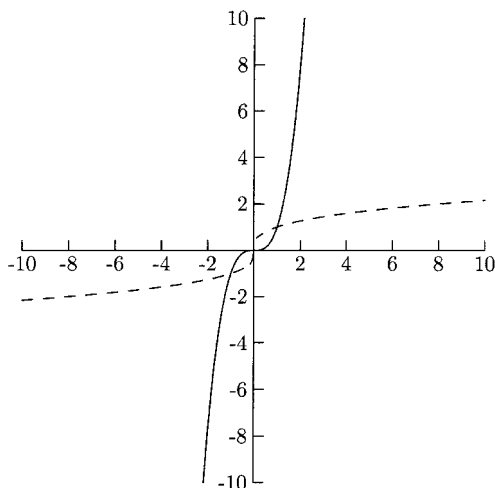

Fig. 4.5.

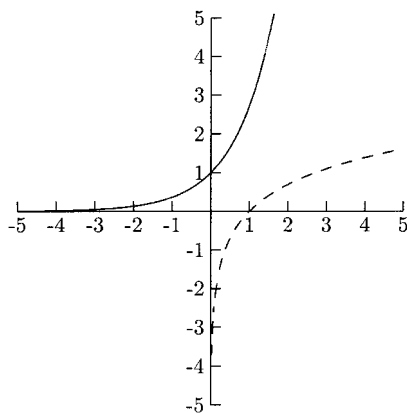
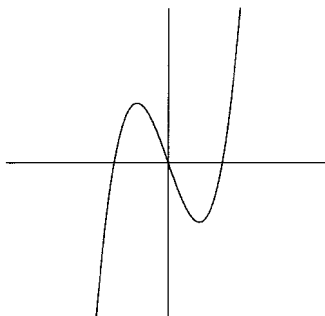

Fig. 4.6.

A function has an inverse if its graph passes the Horizontal Line Test—if any horizontal line touches the graph in more than one place, then the function will not have an inverse. Functions whose graphs pass the Horizontal Line Test are called *one-to-one* functions. For a one-to-one function, every  $x$  will be paired with exactly one  $y$  and every  $y$  will be paired with exactly one  $x$ .

**EXAMPLE**

- The graph of  $f(x)$  is given in Figure 4.7. Is  $f(x)$  one to one?

**Fig. 4.7.**

This graph fails the Horizontal Line Test, so  $f(x)$  is not one to one.

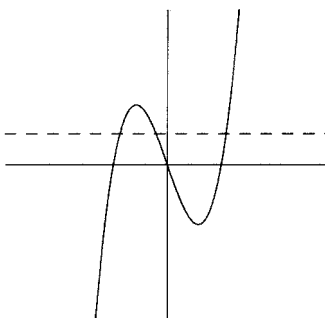
**Fig. 4.8.**

For functions that are not one to one, we can restrict the domain to force the function to be one to one. The function whose graph is in Figure 4.9,  $f(x) = x^2 - 3$ , is not one to one. If we restrict the domain to  $x \geq 0$ , then the new function is one to one.

Finding the inverse function is not hard, but it can be a little tedious. The steps below show the process of algebraically switching  $x$  and  $y$ .

1. Replace  $f(x)$  with  $x$ , and replace  $x$  with  $y$ .
2. Solve this equation for  $y$ .
3. Replace  $y$  with  $f^{-1}(x)$ .

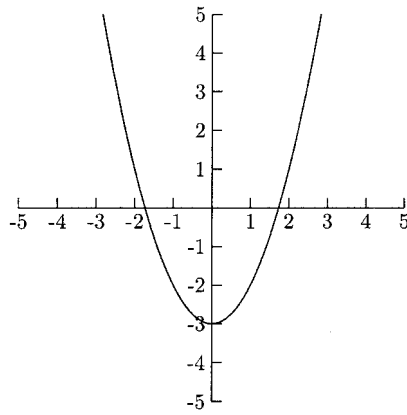

Fig. 4.9.

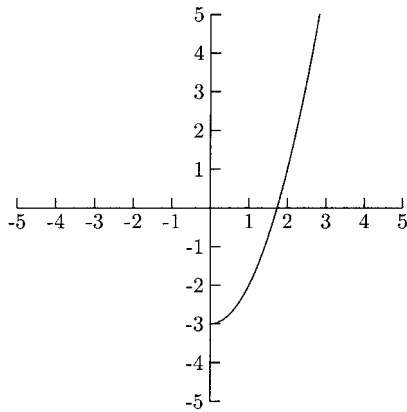

Fig. 4.10.

### EXAMPLES

Find  $f^{-1}(x)$ .

- $f(x) = 6x + 14$

$$x = 6y + 14 \quad \text{Step 1}$$

$$x - 14 = 6y \quad \text{Step 2}$$

$$\frac{x - 14}{6} = y$$

$$f^{-1}(x) = \frac{x - 14}{6} \quad \text{Step 3}$$

- $f(x) = 9(x - 4)^5$

$$x = 9(y - 4)^5 \quad \text{Step 1}$$

$$\frac{x}{9} = (y - 4)^5 \quad \text{Step 2}$$

$$\sqrt[5]{\frac{x}{9}} = y - 4$$

$$\sqrt[5]{\frac{x}{9}} + 4 = y$$

$$f^{-1}(x) = \sqrt[5]{\frac{x}{9}} + 4 \quad \text{Step 3}$$

- $f(x) = \frac{1-x}{2-x}$

$$x = \frac{1-y}{2-y} \quad \text{Step 1}$$

$$x(2-y) = 1-y \quad \text{Step 2}$$

$$2x - xy = 1 - y$$

$$2x - 1 = xy - y \quad \text{y terms on one side, non-y terms on other side}$$

$$2x - 1 = y(x - 1) \quad \text{Factor y}$$

$$\frac{2x - 1}{x - 1} = y$$

$$f^{-1}(x) = \frac{2x - 1}{x - 1} \quad \text{Step 3}$$

## PRACTICE

1. Show that  $f(x) = \frac{1}{2}x + 7$  and  $g(x) = 2x - 14$  are inverses.
2. Show that  $f(x) = \sqrt[3]{x - 8}$  and  $g(x) = x^3 + 8$  are inverses.
3. Show that  $f(x) = \frac{x+2}{x-3}$  and  $g(x) = \frac{3x+2}{x-1}$  are inverses.
4. Use the graph of  $f(x)$  in Figure 4.11 to sketch the graph of  $f^{-1}(x)$ .
5. Find  $f^{-1}(x)$  for  $f(x) = 5x + 12$ .
6. Find  $g^{-1}(x)$  for  $g(x) = \sqrt[3]{2x} - 1$ .
7. Find  $f^{-1}(x)$  for  $f(x) = \frac{2x-3}{6x+1}$ .

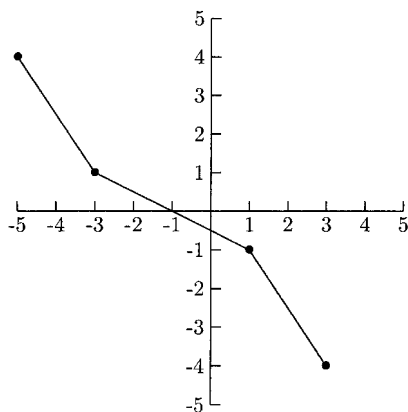

Fig. 4.11.

## SOLUTIONS

1.

$$f \circ g(x) = f(g(x)) = f(2x - 14) = \frac{1}{2}(2x - 14) + 7 = x - 7 + 7 = x$$

$$g \circ f(x) = g(f(x)) = g\left(\frac{1}{2}x + 7\right) = 2\left(\frac{1}{2}x + 7\right) - 14 = x + 14 - 14 = x$$

2.

$$f \circ g(x) = f(g(x)) = f(x^3 + 8) = \sqrt[3]{(x^3 + 8) - 8} = \sqrt[3]{x^3} = x$$

$$g \circ f(x) = g(f(x)) = g(\sqrt[3]{x - 8}) = (\sqrt[3]{x - 8})^3 + 8 = x - 8 + 8 = x$$

3.

$$f \circ g(x) = f(g(x)) = f\left(\frac{3x+2}{x-1}\right) = \frac{\frac{3x+2}{x-1} + 2}{\frac{3x+2}{x-1} - 3}$$

$$= \frac{\frac{3x+2}{x-1} + 2 \cdot \frac{x-1}{x-1}}{\frac{3x+2}{x-1} - 3 \cdot \frac{x-1}{x-1}} = \frac{\frac{3x+2+2(x-1)}{x-1}}{\frac{3x+2-3(x-1)}{x-1}}$$

$$= \frac{\frac{5x}{x-1}}{\frac{5}{x-1}} = \frac{5x}{x-1} \div \frac{5}{x-1}$$

$$= \frac{5x}{x-1} \cdot \frac{x-1}{5} = x$$



$$\begin{aligned}
 g \circ f(x) &= g(f(x)) = g\left(\frac{x+2}{x-3}\right) = \frac{3\left(\frac{x+2}{x-3}\right) + 2}{\frac{x+2}{x-3} - 1} \\
 &= \frac{\frac{3(x+2)}{x-3} + 2 \cdot \frac{x-3}{x-3}}{\frac{x+2}{x-3} - 1 \cdot \frac{x-3}{x-3}} = \frac{\frac{3x+6+2(x-3)}{x-3}}{\frac{x+2-(x-3)}{x-3}} \\
 &= \frac{\frac{5x}{x-3}}{\frac{5}{x-3}} = \frac{5x}{x-3} \div \frac{5}{x-3} \\
 &= \frac{5x}{x-3} \cdot \frac{x-3}{5} = x
 \end{aligned}$$

4. The solid graph in Figure 4.12 is the graph of  $f(x)$ , and the dashed graph is the graph of  $f^{-1}(x)$ .

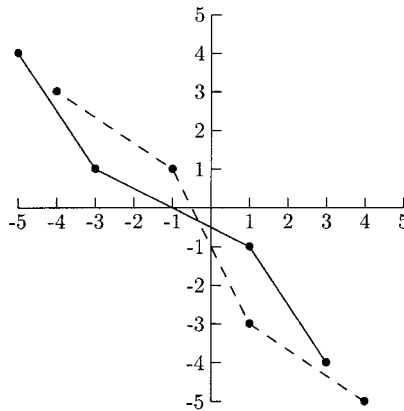

Fig. 4.12.

5.

$$x = 5y + 12$$

$$x - 12 = 5y$$

$$\frac{x - 12}{5} = y \text{ so, } f^{-1}(x) = \frac{x - 12}{5}$$

6.

$$x = \sqrt[3]{2y} - 1$$

$$x + 1 = \sqrt[3]{2y}$$

$$(x + 1)^3 = 2y$$

$$\frac{(x + 1)^3}{2} = y \text{ so } g^{-1}(x) = \frac{(x + 1)^3}{2}$$

7.

$$x = \frac{2y - 3}{6y + 1}$$

$$x(6y + 1) = 2y - 3$$

$$6xy + x = 2y - 3$$

$$x + 3 = 2y - 6xy$$

$$x + 3 = y(2 - 6x)$$

$$\frac{x + 3}{2 - 6x} = y \text{ so } f^{-1}(x) = \frac{x + 3}{2 - 6x}$$

## CHAPTER 4 REVIEW

Problems 1–5 refer to  $f(x) = \frac{1}{x-3}$  and  $g(x) = 2x + 4$ .

- Find the domain for  $f + g(x)$ .
 

(a) $(3, \infty)$	(b) $(-\infty, 3) \cup (3, \infty)$
(c) $(-\infty, 3] \cup [3, \infty)$	(d) $[3, \infty)$
- Find  $f \circ g(x)$ .
 

(a) $\frac{1}{2x+1}$	(b) $x - 3$	(c) $\frac{2}{x-3} + 4$	(d) $\frac{2x+4}{x-3}$
----------------------	-------------	-------------------------	------------------------
- Find  $g \circ f(x)$ .
 

(a) $\frac{1}{2x+1}$	(b) $x - 3$	(c) $\frac{2}{x-3} + 4$	(d) $\frac{2x+4}{x-3}$
----------------------	-------------	-------------------------	------------------------
- Find  $f \circ g(4)$ .
 

(a) 12	(b) $\frac{1}{9}$	(c) 6	(d) 48
--------	-------------------	-------	--------
- Find  $f^{-1}(x)$ .
 

(a) $x - 3$	(b) $\frac{3x+1}{x+1}$	(c) $\frac{3x+1}{x}$	(d) $\frac{3x+1}{x-3}$
-------------	------------------------	----------------------	------------------------
- The graph of  $f(x)$  is given in Figure 4.13. Does  $f(x)$  have an inverse?
 

(a) Yes	(b) No	(c) Cannot be determined
---------	--------	--------------------------

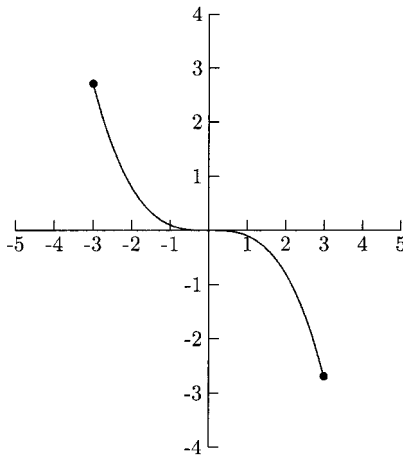

Fig. 4.13.

7. Are  $f(x) = \frac{1}{2}x + 3$  and  $g(x) = 2x - 3$  inverses?  
 (a) Yes                      (b) No                      (c) Cannot be determined
8. What is the domain for  $f \circ g(x)$  where

$$f(x) = \frac{1}{x} \quad \text{and} \quad g(x) = \frac{x-2}{x+2}?$$

- (a)  $(-\infty, -2) \cup (-2, 0) \cup (0, 2) \cup (2, \infty)$   
 (b)  $(-\infty, -2) \cup (-2, 2) \cup (2, \infty)$

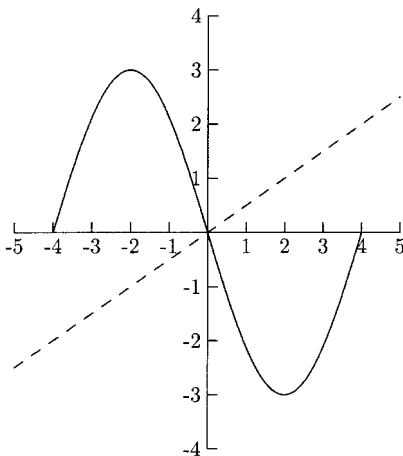

Fig. 4.14.

- (c)  $(-\infty, 0) \cup (0, 2) \cup (2, \infty)$   
(d)  $(-\infty, -2) \cup (-2, 0) \cup (0, \infty)$

9. The solid graph in Figure 4.14 is the graph of  $f(x)$ . The dashed graph is the graph of  $g(x)$ . Find  $f \circ g(4)$ .

- (a)  $-2$                       (b)  $-3$                       (c)  $2$                       (d)  $3$

### SOLUTIONS

1. B            2. A            3. C            4. B            5. C  
6. A            7. B            8. B            9. B



## CHAPTER

# Translations and Special Functions

Calculus students work with only a few families of functions—absolute value,  $n$ th root, cubic, quadratic, polynomial, rational, exponential, logarithmic, and trigonometric functions. Two or more of these functions might be combined arithmetically or by using function composition. In this chapter, we will look at the absolute value function (whose graph is in Figure 5.1), the square root function (whose graph is in Figure 5.2), and the cubic function (whose graph is in Figure 5.3).

We will also look at how these functions are affected by some simple changes. Knowing the effects certain changes have on a function will make sketching its graph by hand much easier. This understanding will also help you to use a graphing calculator. One of the simplest changes to a function is to add a number. This change will cause the graph to shift vertically or horizontally.

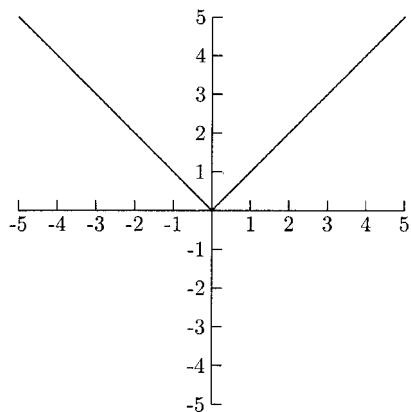

Fig. 5.1.

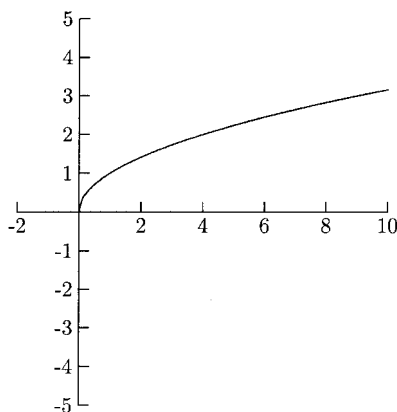

Fig. 5.2.

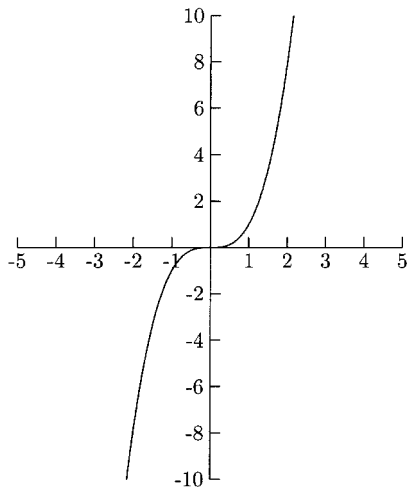

Fig. 5.3.

What effect does adding 1 to a function have on its graph? It depends on where we put “+1.” Adding 1 to  $x$  will shift the graph *left* one unit. Adding 1 to  $y$  will shift the graph *up* one unit.

- $y = |x+1|$ , 1 is added to  $x$ , shifting the graph to the left 1 unit. See Figure 5.4.
- $y = |x| + 1$ , 1 is added to  $y$  (which is  $|x|$ ) shifting the graph up 1 unit. See Figure 5.5.

For the graphs in this chapter, the solid graph will be the graph of the original function, and the dashed graph will be the graph of the transformed function.

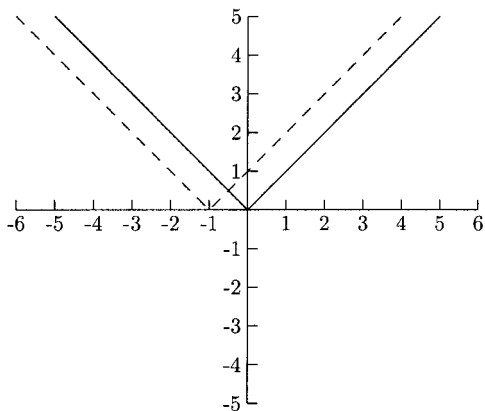

Fig. 5.4.

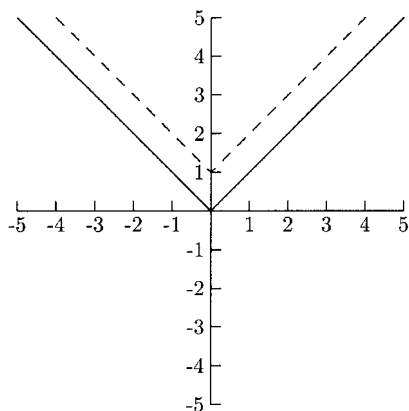

Fig. 5.5.

- $y = \sqrt{x+2}$ , 2 is added to  $x$ , shifting the graph to the left 2 units. See Figure 5.6.
- $y = \sqrt{x} + 2$ , 2 is added to  $y$  (which is  $\sqrt{x}$ ) shifting the graph up 2 units. See Figure 5.7.

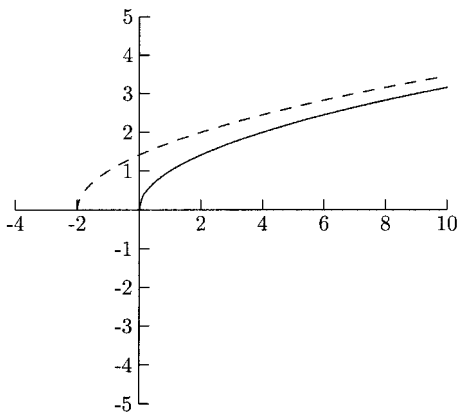

Fig. 5.6.

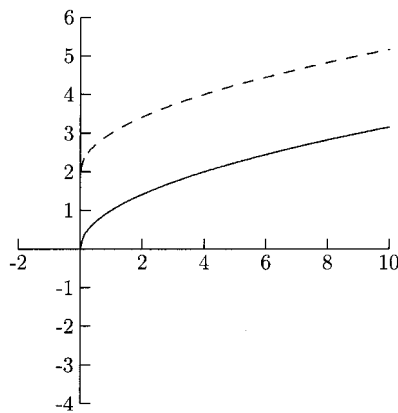

Fig. 5.7.

Subtracting a number from  $x$  will shift the graph to the right while subtracting a number from  $y$  will shift the graph down.

- $y = (x - 1)^3$ , 1 is subtracted from  $x$ , shifting the graph to the right 1 unit. See Figure 5.8.
- $y = x^3 - 1$ , 1 is subtracted from  $y$  (which is  $x^3$ ), shifting the graph down 1 unit. See Figure 5.9.

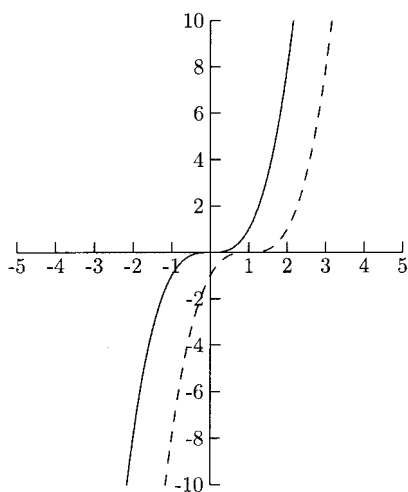

Fig. 5.8.

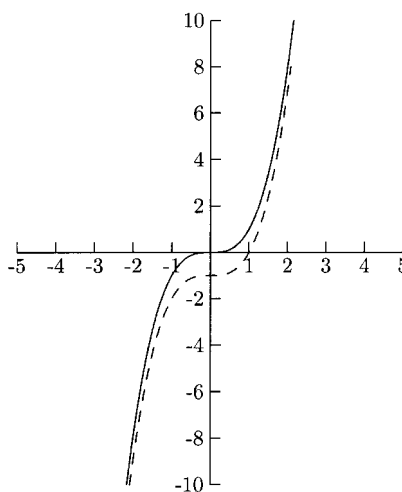

Fig. 5.9.

Multiplying the  $x$ -values or  $y$ -values by a number changes the graph, usually by stretching or compressing it. Multiplying the  $x$ -values or  $y$ -values by  $-1$  will reverse the graph. If  $a$  is a number larger than 1 ( $a > 1$ ), then multiplying  $x$  by  $a$  will horizontally compress the graph, but multiplying  $y$  by  $a$  will vertically stretch the graph. If  $a$  is positive but less than 1 ( $0 < a < 1$ ), then multiplying  $x$  by  $a$  will horizontally stretch the graph, but multiplying  $y$  by  $a$  will vertically compress the graph.

- $y = \sqrt{2x}$ , the graph is horizontally compressed. See Figure 5.10.
- $y = 2\sqrt{x}$ , the graph is vertically stretched. See Figure 5.11.
- $y = \left(\frac{1}{2}x\right)^3$ , the graph is horizontally stretched. See Figure 5.12.
- $y = \frac{1}{2}x^3$ , the graph is vertically compressed. See Figure 5.13.



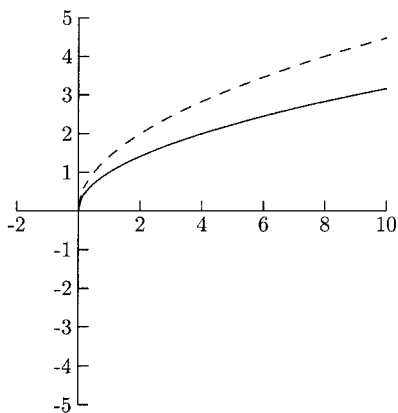

Fig. 5.10.

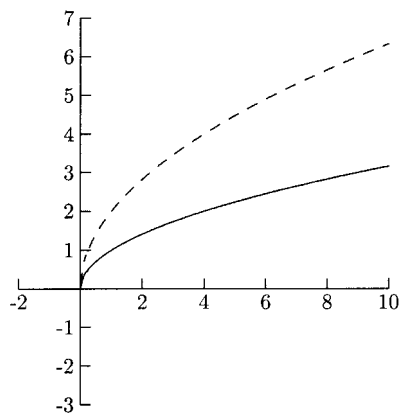

Fig. 5.11.

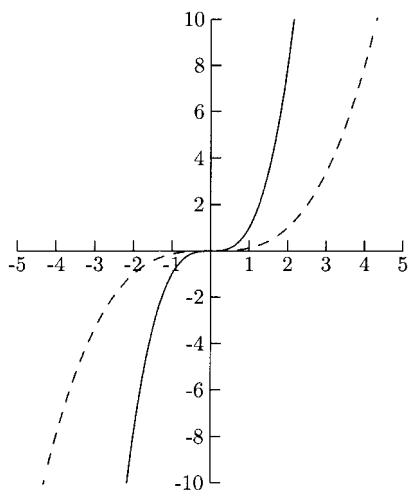

Fig. 5.12.

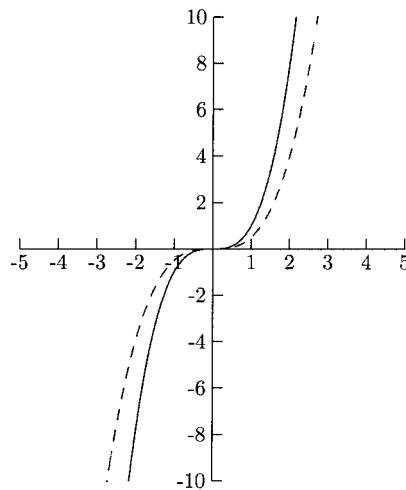

Fig. 5.13.

For many functions, but not all, vertical compression is the same as horizontal stretching, and vertical stretching is the same as horizontal compression.

Multiplying the  $x$ -values by  $-1$  will reverse the graph horizontally. This is called *reflecting the graph across the  $y$ -axis*. Multiplying the  $y$ -values by  $-1$  will reverse the graph vertically. This is called *reflecting the graph across the  $x$ -axis*.

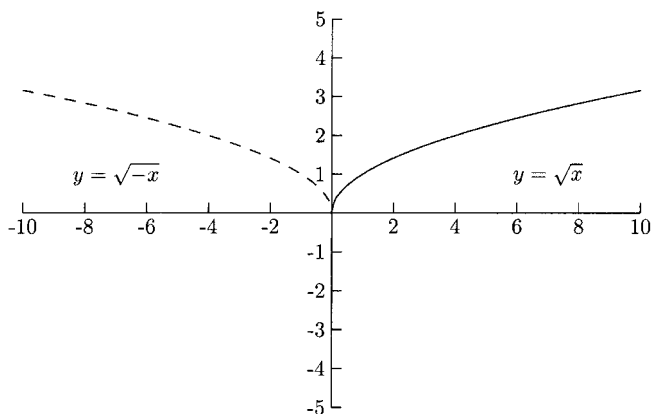

Fig. 5.14.

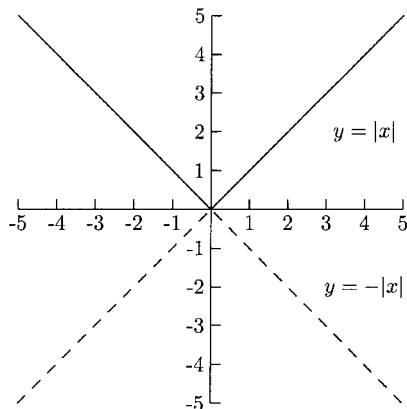

Fig. 5.15.

When a function is even, reflecting the graph across the  $y$ -axis does not change the graph. When a function is odd, reflecting the graph across the  $y$ -axis is the same as reflecting it across the  $x$ -axis.

We can use function notation to summarize these transformations.

$$y = af(x + h) + k$$

- If  $h$  is positive, the graph is shifted to the left  $h$  units.
- If  $h$  is negative, the graph is shifted to the right  $h$  units.
- If  $k$  is positive, the graph is shifted up  $k$  units.
- If  $k$  is negative, the graph is shifted down  $k$  units.

- If  $a > 1$ , the graph is vertically stretched. The larger  $a$  is, the greater the stretch.
- If  $0 < a < 1$ , the graph is vertically compressed. The closer to 0  $a$  is, the greater the compression.
- The graph of  $-f(x)$  is reflected across the  $x$ -axis.
- The graph of  $f(-x)$  is reflected across the  $y$ -axis.

The graphs below are various transformations of the graph of  $y = |x|$ .

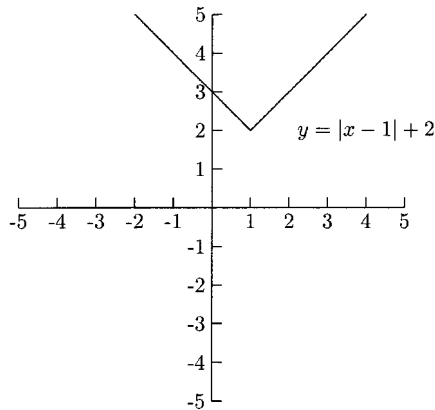

Fig. 5.16.

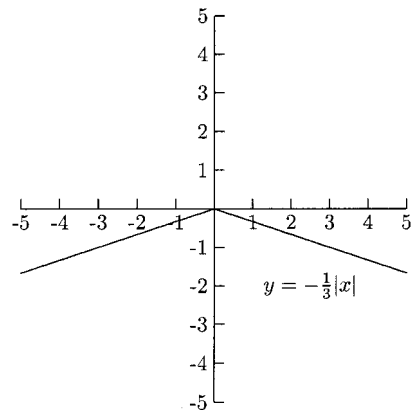

Fig. 5.17.

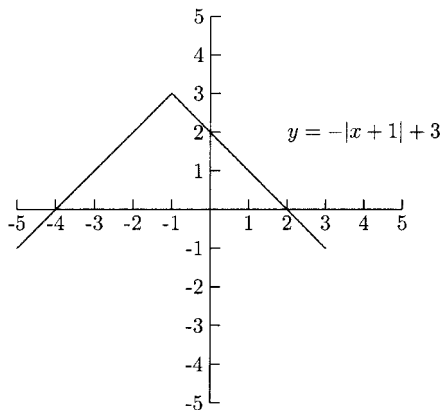

Fig. 5.18.

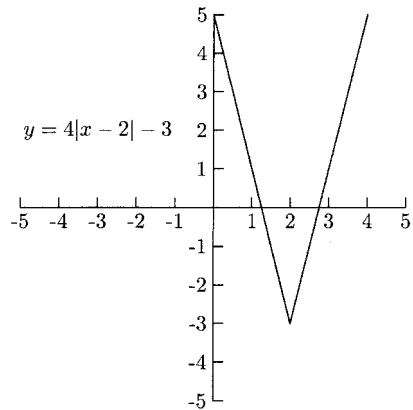
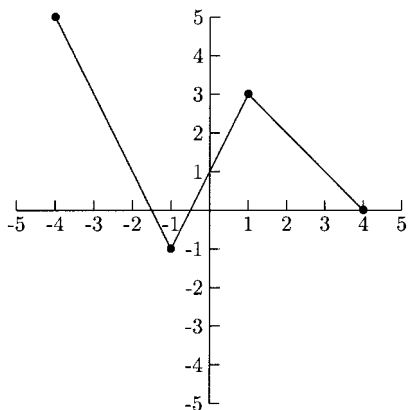

Fig. 5.19.

**EXAMPLES**

The graph of  $y = f(x)$  is given in Figure 5.20. Sketch the transformations. We will sketch the graph by moving the points  $(-4, 5)$ ,  $(-1, -1)$ ,  $(1, 3)$ , and  $(4, 0)$ .

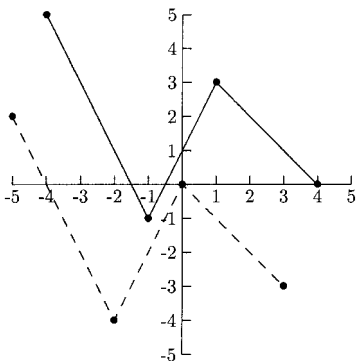

**Fig. 5.20.**

- $y = f(x + 1) - 3$

**Table 5.1**

Original point	Left 1 $x - 1$	Down 3 $y - 3$	Plot this point
$(-4, 5)$	$-4 - 1 = -5$	$5 - 3 = 2$	$(-5, 2)$
$(-1, -1)$	$-1 - 1 = -2$	$-1 - 3 = -4$	$(-2, -4)$
$(1, 3)$	$1 - 1 = 0$	$3 - 3 = 0$	$(0, 0)$
$(4, 0)$	$4 - 1 = 3$	$0 - 3 = -3$	$(3, -3)$



**Fig. 5.21.**

- $y = -f(x)$

Table 5.2

Original point	$x$ does not change $x$	Opposite of $y$ $-y$	Plot this point
$(-4, 5)$	$-4$	$-5$	$(-4, -5)$
$(-1, -1)$	$-1$	$-(-1) = 1$	$(-1, 1)$
$(1, 3)$	$1$	$-3$	$(1, -3)$
$(4, 0)$	$4$	$-0 = 0$	$(4, 0)$

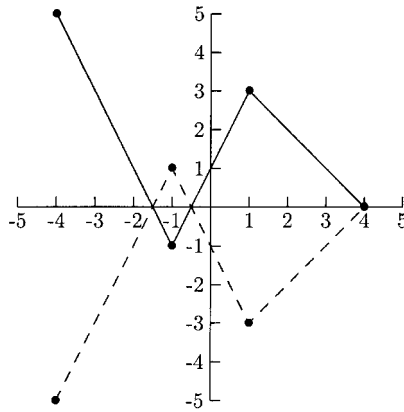

Fig. 5.22.

- $y = 2f(x - 3)$

Table 5.3

Original point	Right 3 $x + 3$	Stretched $2y$	Plot this point
$(-4, 5)$	$-4 + 3 = -1$	$2(5) = 10$	$(-1, 10)$
$(-1, -1)$	$-1 + 3 = 2$	$2(-1) = -2$	$(2, -2)$
$(1, 3)$	$1 + 3 = 4$	$2(3) = 6$	$(4, 6)$
$(4, 0)$	$4 + 3 = 7$	$2(0) = 0$	$(7, 0)$

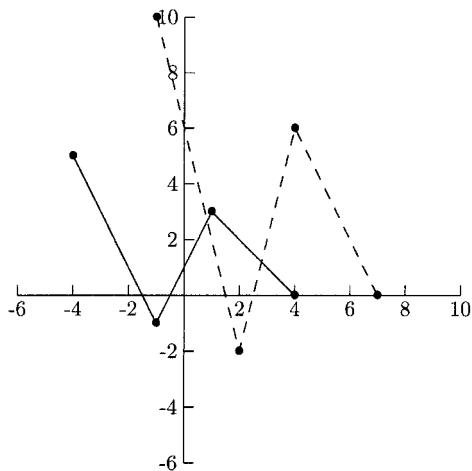

Fig. 5.23.

- $y = \frac{1}{2}f(-x) + 2$

Table 5.4

Original point	Opposite of $x$ $-x$	Compressed and up 2 $\frac{1}{2}y + 2$	Plot this point
$(-4, 5)$	$-(-4) = 4$	$\frac{1}{2}(5) + 2 = \frac{9}{2}$	$(4, \frac{9}{2})$
$(-1, -1)$	$-(-1) = 1$	$\frac{1}{2}(-1) + 2 = \frac{3}{2}$	$(1, \frac{3}{2})$
$(1, 3)$	$-1$	$\frac{1}{2}(3) + 2 = \frac{7}{2}$	$(-1, \frac{7}{2})$
$(4, 0)$	$-4$	$\frac{1}{2}(0) + 2 = 2$	$(-4, 2)$

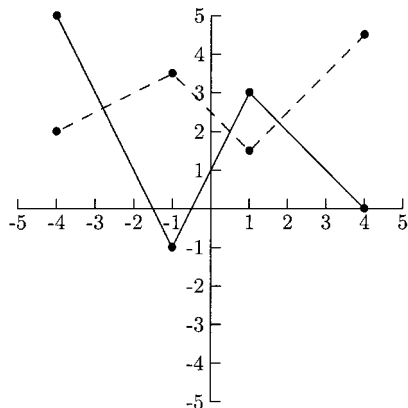
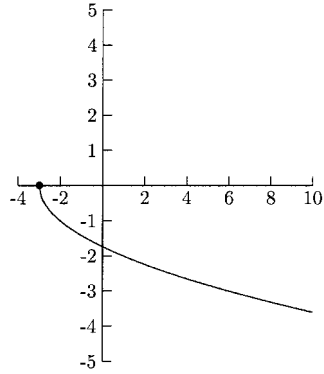

Fig. 5.24.

**PRACTICE**

For 1–4, match the graph with its function. Some functions will be left over.

1.



**Fig. 5.25.**

2.

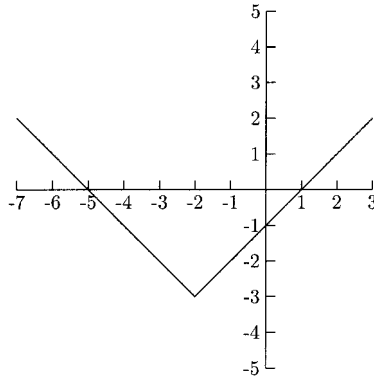

**Fig. 5.26.**

3.

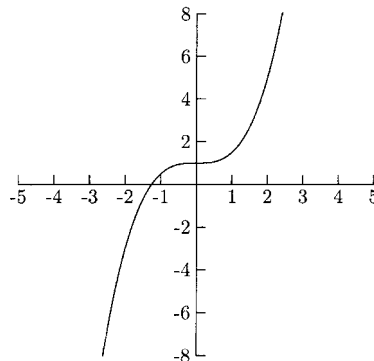

**Fig. 5.27.**

4.

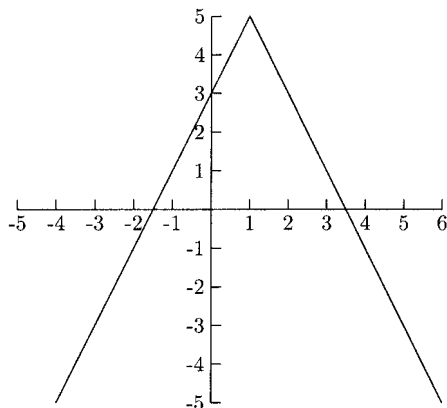

Fig. 5.28.

$$f(x) = -2|x - 1| + 5 \quad f(x) = -\sqrt{x + 3} \quad f(x) = \sqrt{3 - x}$$

$$f(x) = -\frac{1}{2}x^3 + 1 \quad f(x) = |x + 2| - 3 \quad f(x) = \frac{1}{2}x^3 + 1$$

For Problems 5–8, use the statements below to describe the transformations on  $f(x)$ . Some of the statements will be used more than once, and others will not be used.

- (A) shifts the graph to the left.
  - (B) shifts the graph to the right.
  - (C) shifts the graph up.
  - (D) shifts the graph down.
  - (E) reflects the graph across the  $y$ -axis.
  - (F) reflects the graph across the  $x$ -axis.
  - (G) vertically compresses the graph.
  - (H) vertically stretches the graph.
  - (I) reflects the graph across the  $x$ -axis and vertically compresses the graph.
  - (J) reflects the graph across the  $y$ -axis and vertically stretches the graph.
5. For the function  $f(-x) + 3$ ,
- (a) What does “+3” do?
  - (b) What does the negative sign on  $x$  do?
6. For the function  $3f(x - 1) - 4$ ,
- (a) What does “3” do?



- (b) What does “ $-1$ ” do?  
 (c) What does “ $-4$ ” do?
7. For the function  $-\frac{1}{2}f(x+3)+1$ ,
- (a) What does “ $-\frac{1}{2}$ ” do?  
 (b) What does “ $+3$ ” do?  
 (c) What does “ $+1$ ” do?
8. For the function  $\frac{1}{3}f(-x)-1$ ,
- (a) What does “ $\frac{1}{3}$ ” do?  
 (b) What does the negative sign on  $x$  do?  
 (c) What does “ $-1$ ” do?

Refer to the graph of  $f(x)$  in Figure 5.29 for Problems 9–10.

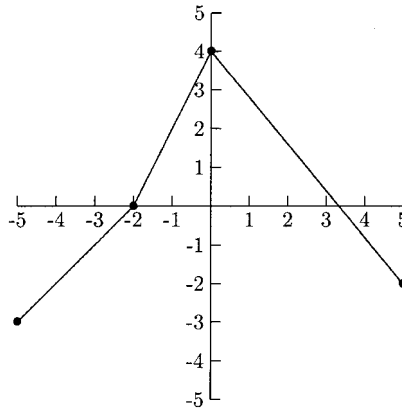

Fig. 5.29.

9. Sketch the graph of  $f(-x)-1$ .  
 10. Sketch the graph of  $-\frac{1}{2}f(x+3)+1$ .

## SOLUTIONS

- $f(x) = -\sqrt{x+3}$
- $f(x) = |x+2| - 3$
- $f(x) = \frac{1}{2}x^3 + 1$
- $f(x) = -2|x-1| + 5$

- 5. C, E
- 6. H, B, D
- 7. I, A, C
- 8. G, E, D
- 9.

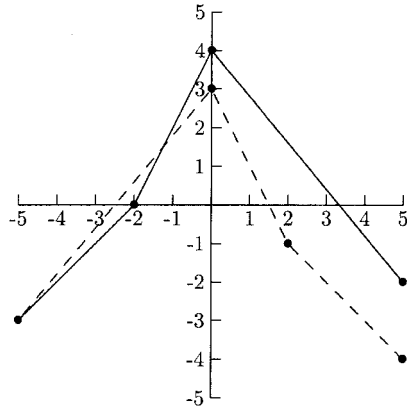

Fig. 5.30.

Table 5.5

Original point	Opposite of $x$ $-x$	Down 1 $y - 1$	Plot this point
$(-5, -3)$	$-(-5) = 5$	$-3 - 1 = -4$	$(5, -4)$
$(-2, 0)$	$-(-2) = 2$	$0 - 1 = -1$	$(2, -1)$
$(0, 4)$	$-0 = 0$	$4 - 1 = 3$	$(0, 3)$
$(5, -2)$	$-5$	$-2 - 1 = -3$	$(-5, -3)$

10.

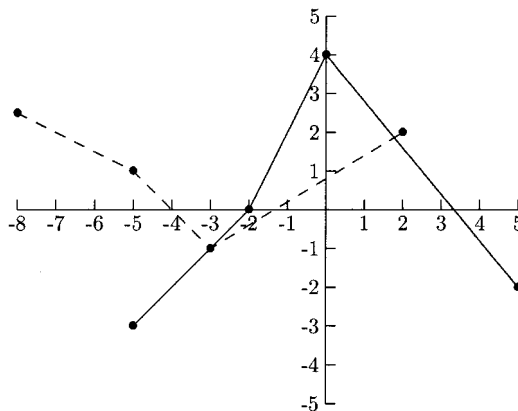

Fig. 5.31.

Table 5.6

Original point	Left 3 $x - 3$	Opposite of $y$ , compressed, up 1 $-\frac{1}{2}y + 1$	Plot this point
$(-5, -3)$	$-5 - 3 = -8$	$-\frac{1}{2}(-3) + 1 = \frac{5}{2}$	$(-8, \frac{5}{2})$
$(-2, 0)$	$-2 - 3 = -5$	$-\frac{1}{2}(0) + 1 = 1$	$(-5, 1)$
$(0, 4)$	$0 - 3 = -3$	$-\frac{1}{2}(4) + 1 = -1$	$(-3, -1)$
$(5, -2)$	$5 - 3 = 2$	$-\frac{1}{2}(-2) + 1 = 2$	$(2, 2)$

CHAPTER 5 REVIEW

Match the graphs in Figures 5.32–5.34 with the functions in Problems 1–3.

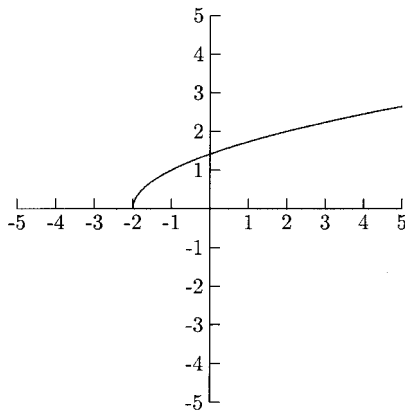

Fig. 5.32.

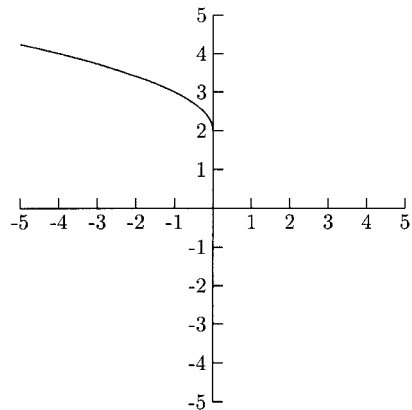

Fig. 5.33.

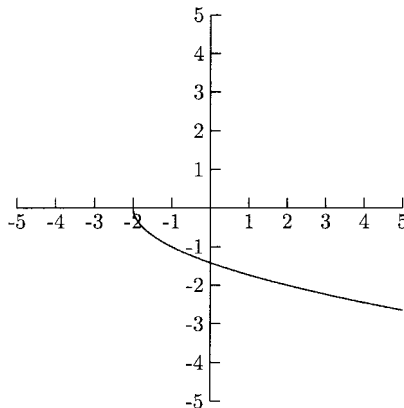

Fig. 5.34.

1.  $f(x) = \sqrt{x + 2}$
2.  $f(x) = -\sqrt{x + 2}$
3.  $f(x) = \sqrt{-x} + 2$
4. The graph of  $f(x) = (x + 1) + 2$  is the graph of  $f(x)$ 
  - (a) shifted to the left one unit and down two units.
  - (b) shifted to the left one unit and up two units.
  - (c) shifted to the right one unit and down two units.
  - (d) shifted to the right one unit and up two units.

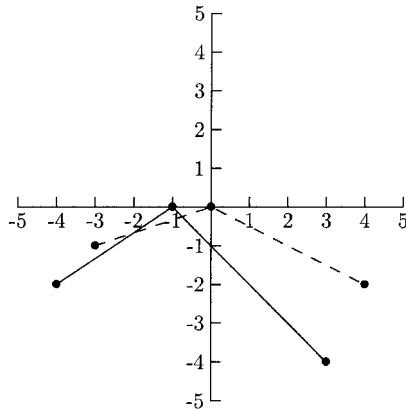

Fig. 5.35.

5. The solid graph in Figure 5.35 is the graph of  $f(x)$ , and the dashed graph is the graph of a transformation. What is the transformation?
 

(a) $\frac{1}{2}f(x - 1)$	(b) $\frac{1}{2}f(x + 1)$
(c) $f(x - 1) + \frac{1}{2}$	(d) $f(x + 1) + \frac{1}{2}$

**SOLUTIONS**

1. Figure 5.32      2. Figure 5.34      3. Figure 5.33      4. B      5. A



## CHAPTER

# Quadratic Functions

The graph of every quadratic function,  $f(x) = ax^2 + bx + c$ , is a transformation of the graph of  $y = x^2$ . (See Figure 6.1.)

When the function is written in the form  $f(x) = a(x - h)^2 + k$ , we have a pretty good idea of what its graph looks like:  $h$  will cause the graph to shift horizontally, and  $k$  will cause it to shift vertically. The point  $(0, 0)$  on  $y = x^2$  has shifted to  $(h, k)$ . This point is the *vertex*. On a parabola that opens up (when  $a$  is positive), the vertex is the lowest point on the graph. The vertex is the highest point on a parabola that opens down (when  $a$  is negative).

We need to know the vertex when sketching a parabola. Once we have the vertex, we will find two points to its left and two points to its right. We should choose points in such a way that shows the curvature around the vertex and how fast the ends are going up or down. It does not matter which points we choose, but a good rule of thumb is to find  $h - 2a$ ,  $h - a$ ,  $h + a$ , and  $h + 2a$ . Because a parabola is symmetric

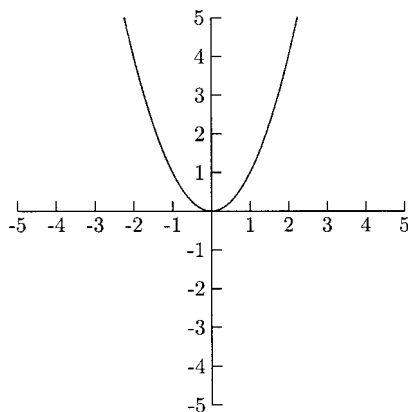

Fig. 6.1.

about the line  $x = h$  (the vertical line that goes through the vertex), the  $y$ -values for  $h - a$  and  $h + a$  will be the same and the  $y$ -values for  $h - 2a$  and  $h + 2a$  will be the same, too. We will also find the intercepts.

## EXAMPLES

Sketch the graph for the following quadratic functions. Find the  $y$ -intercept and the  $x$ -intercepts, if any.

- $f(x) = (x - 1)^2 - 4$

$a = 1$ ,  $h = 1$ ,  $k = -4$  The parabola opens up and the vertex is  $(1, -4)$ .

For the  $y$ -intercept, let  $x = 0$  in the function. The  $y$ -intercept is  $(0 - 1)^2 - 4 = -3$ . For the  $x$ -intercepts, let  $y = 0$  and solve for  $x$ .

$$(x - 1)^2 - 4 = 0$$

$$(x - 1)^2 = 4 \quad \text{Take the square root of each side.}$$

$$x - 1 = \pm 2$$

$$x = 1 \pm 2 = 1 + 2, 1 - 2 = 3, -1$$

The  $x$ -intercepts are 3 and  $-1$ .

Table 6.1

	$x$	$y$	Plot this point
$h - 2a$	$1 - 2(1) = -1$	$(-1 - 1)^2 - 4 = 0$	$(-1, 0)$
$h - a$	$1 - 1 = 0$	$(0 - 1)^2 - 4 = -3$	$(0, -3)$
$h$	$1$	$-4$	$(1, -4)$
$h + a$	$1 + 1 = 2$	$(2 - 1)^2 - 4 = -3$	$(2, -3)$
$h + 2a$	$1 + 2(1) = 3$	$(3 - 1)^2 - 4 = 0$	$(3, 0)$

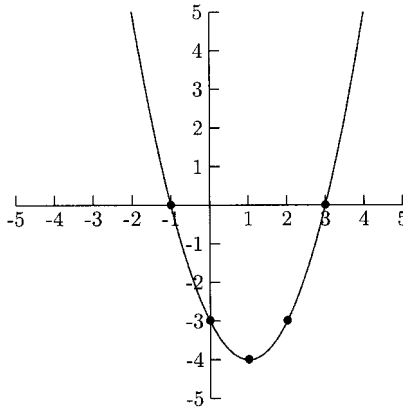

Fig. 6.2.

- $g(x) = -2(x + 1)^2 + 18$   
 $a = -2, h = -1, k = 18$  The parabola opens down, and the vertex is  $(-1, 18)$ .

$$y = -2(0 + 1)^2 + 18 \qquad -2(x + 1)^2 + 18 = 0$$

$$y = 16 \qquad -2(x + 1)^2 = -18$$

$$(x + 1)^2 = 9$$

$$x + 1 = \pm 3$$

$$x = -1 \pm 3 = -1 - 3,$$

$$-1 + 3 = -4, 2$$

The  $y$ -intercept is 16 and the  $x$ -intercepts are  $-4$  and  $2$ .

Table 6.2

	$x$	$y$	Plot this point
$h - 2a$	$-1 - 2(-2) = 3$	$-2(3 + 1)^2 + 18 = -14$	$(3, -14)$
$h - a$	$-1 - (-2) = 1$	$-2(1 + 1)^2 + 18 = 10$	$(1, 10)$
$h$	$-1$	$18$	$(-1, 18)$
$h + a$	$-1 + (-2) = -3$	$-2(-3 + 1)^2 + 18 = 10$	$(-3, 10)$
$h + 2a$	$-1 + 2(-2) = -5$	$-2(-5 + 1)^2 + 18 = -14$	$(-5, -14)$

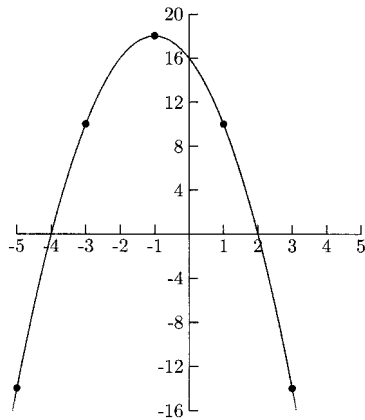

Fig. 6.3.

- $f(x) = \frac{1}{2}(x + 1)^2 + 2$   
 $a = \frac{1}{2}, h = -1, k = 2$  The parabola opens up, and the vertex is  $(-1, 2)$ . Because the parabola opens up ( $a = \frac{1}{2}$  is positive) and the vertex is above the  $x$ -axis ( $k = 2$  is positive), there will be no  $x$ -intercept. If we were to solve the equation  $\frac{1}{2}(x + 1)^2 + 2 = 0$ , we would not get a real number solution. The  $y$ -intercept is  $y = \frac{1}{2}(0 + 1)^2 + 2 = 2\frac{1}{2}$ .

Table 6.3

	$x$	$y$	Plot this point
$h - 2a$	$-1 - 2(\frac{1}{2}) = -2$	$\frac{1}{2}(-2 + 1)^2 + 2 = 2\frac{1}{2}$	$(-2, 2\frac{1}{2})$
$h - a$	$-1 - \frac{1}{2} = -1\frac{1}{2}$	$\frac{1}{2}(-1\frac{1}{2} + 1)^2 + 2 = 2\frac{1}{8}$	$(-1\frac{1}{2}, 2\frac{1}{8})$
$h$	$-1$	$2$	$(-1, 2)$
$h + a$	$-1 + \frac{1}{2} = -\frac{1}{2}$	$\frac{1}{2}(-\frac{1}{2} + 1)^2 + 2 = 2\frac{1}{8}$	$(-\frac{1}{2}, 2\frac{1}{8})$
$h + 2a$	$-1 + 2(\frac{1}{2}) = 0$	$\frac{1}{2}(0 + 1)^2 + 2 = 2\frac{1}{2}$	$(0, 2\frac{1}{2})$



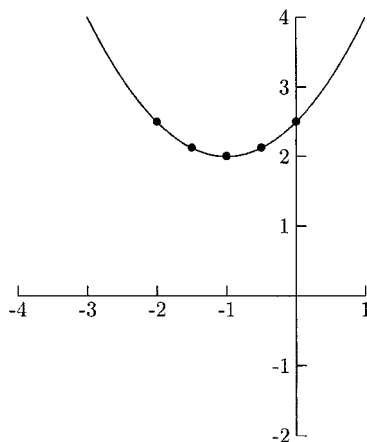

Fig. 6.4.

By knowing the vertex and one other point on the graph, we can find an equation for the quadratic function. Once we know the vertex, we have  $h$  and  $k$  in  $y = a(x - h)^2 + k$ . By using another point  $(x, y)$ , we can find  $a$ .

### EXAMPLE

- The vertex for a quadratic function is  $(-3, 4)$ , and the  $y$ -intercept is  $-10$ . Find an equation for this function.  
Let  $h = -3$ ,  $k = 4$  in  $y = a(x - h)^2 + k$  to get  $y = a(x + 3)^2 + 4$ . Saying that the  $y$ -intercept is  $-10$  is another way of saying  $(0, -10)$  is a point on the graph. We can let  $x = 0$  and  $y = -10$  in  $y = a(x + 3)^2 + 4$  to find  $a$ .

$$-10 = a(0 + 3)^2 + 4$$

$$-14 = 9a$$

$$-\frac{14}{9} = a$$

One equation for this function is  $y = -\frac{14}{9}(x + 3)^2 + 4$ .

Quadratic equations are not normally written in the convenient form  $f(x) = a(x - h)^2 + k$ . We can complete the square on  $f(x) = ax^2 + bx + c$  to find  $(h, k)$ . Begin by completing the square on the  $x^2$  and  $x$  terms.

## EXAMPLES

Find the vertex.

- $y = x^2 - 6x - 2$

$$y = x^2 - 6x - 2$$

$$y = \left[ x^2 - 6x + \left( \frac{6}{2} \right)^2 \right] - 2 + ?$$

We need to balance putting  $+(6/2)^2 = 9$  in the parentheses by adding  $-9$  to  $-2$

$$y = (x^2 - 6x + 9) - 2 - 9$$

$$y = (x - 3)^2 - 11 \quad \text{The vertex is } (3, -11).$$

- $f(x) = 4x^2 + 8x + 1$

We will begin by factoring  $a = 4$  from  $4x^2 + 8x$ . Then we will complete the square on the  $x^2$  and  $x$  terms.

$$f(x) = 4x^2 + 8x + 1$$

$$f(x) = 4(x^2 + 2x) + 1$$

$$f(x) = 4(x^2 + 2x + 1) + 1 + ?$$

By putting  $+1$  in the parentheses, we are adding  $4(1) = 4$ . We need to balance this by adding  $-4$  to  $1$ .

$$f(x) = 4(x^2 + 2x + 1) + 1 + (-4)$$

$$f(x) = 4(x + 1)^2 - 3 \quad \text{The vertex is } (-1, -3).$$

When factoring an unusual quantity from two or more terms, it is not obvious what terms go in the parentheses. We can find the terms that go in the parentheses by writing the terms to be factored as numerators of fractions and the number to be factored as the denominator. The terms that go in the parentheses are the simplified fractions.

- $f(x) = -3x^2 + 9x + \frac{1}{4}$

We need to factor  $a = -3$  from  $-3x^2 + 9x$ .

$$\frac{-3x^2}{-3} + \frac{9x}{-3} = x^2 - 3x$$

$$f(x) = -3x^2 + 9x + \frac{1}{4}$$

$$f(x) = -3(x^2 - 3x) + \frac{1}{4}$$

$$f(x) = -3\left(x^2 - 3x + \frac{9}{4}\right) + \frac{1}{4} + ? \quad \left(\frac{3}{2}\right)^2 = \frac{9}{4}$$

By putting  $+\frac{9}{4}$  in the parentheses, we are adding  $-3\left(\frac{9}{4}\right) = -\frac{27}{4}$ . We need to balance this by adding  $\frac{27}{4}$  to  $\frac{1}{4}$

$$f(x) = -3\left(x^2 - 3x + \frac{9}{4}\right) + \frac{1}{4} + \frac{27}{4} = -3\left(x^2 - 3x + \frac{9}{4}\right) + \frac{28}{4}$$

$$f(x) = -3\left(x - \frac{3}{2}\right)^2 + 7 \quad \text{The vertex is } \left(\frac{3}{2}, 7\right)$$

- $g(x) = \frac{2}{3}x^2 + x - 2$

Factoring  $a = \frac{2}{3}$  from  $\frac{2}{3}x^2 + x$ , we have

$$\frac{(2/3)x^2}{2/3} + \frac{x}{2/3} = x^2 + x \div \frac{2}{3} = x^2 + x \cdot \frac{3}{2} = x^2 + \frac{3}{2}x.$$

$$g(x) = \frac{2}{3}\left(x^2 + \frac{3}{2}x\right) - 2$$

$$= \frac{2}{3}\left(x^2 + \frac{3}{2}x + \frac{9}{16}\right) - 2 + ? \quad \left(\frac{1}{2} \cdot \frac{3}{2}\right)^2 = \frac{9}{16}$$

By adding  $\frac{9}{16}$  in the parentheses, we are adding  $\frac{2}{3} \cdot \frac{9}{16} = \frac{3}{8}$ . We need to balance this by adding  $-3/8$  to  $-2$ .

$$g(x) = \frac{2}{3} \left( x^2 + \frac{3}{2}x + \frac{9}{16} \right) - 2 - \frac{3}{8}$$

$$g(x) = \frac{2}{3} \left( x + \frac{3}{4} \right)^2 - \frac{19}{8} \quad \text{The vertex is } \left( -\frac{3}{4}, -\frac{19}{8} \right)$$

One advantage to the form  $f(x) = ax^2 + bx + c$  is that it is usually easier to use to find the intercepts. We can use factoring and the quadratic formula when it is in this form. Also,  $c$  is the  $y$ -intercept. Because  $a$  is the same number in both forms, we can tell whether the parabola opens up or down when the equation is in either form. It can be tedious to complete the square on  $f(x) = ax^2 + bx + c$  to find the vertex. Fortunately, there is a shortcut.

$$h = \frac{-b}{2a} \quad \text{and} \quad k = f\left(\frac{-b}{2a}\right)$$

This shortcut comes from completing the square to rewrite  $f(x) = ax^2 + bx + c$  as  $f(x) = a(x - h)^2 + k$ .

$$\begin{aligned} f(x) &= ax^2 + bx + c \\ &= a \left( x^2 + \frac{b}{a}x \right) + c \\ &= a \left( x^2 + \frac{b}{a}x + \left( \frac{b}{2a} \right)^2 \right) + c - a \cdot \left( \frac{b}{2a} \right)^2 \\ &= a \left( x + \frac{b}{2a} \right)^2 + c - \frac{b^2}{4a} \quad \text{The vertex is } \left( \frac{-b}{2a}, c - \frac{b^2}{4a} \right) \end{aligned}$$

It is easier to find  $k$  by evaluating the function at  $x = \frac{-b}{2a}$  than by using this formula.

## EXAMPLE

Use the shortcut to find the vertex.

- $f(x) = -3x^2 + 9x + 4$

$$h = \frac{-b}{2a} = \frac{-9}{2(-3)} = \frac{3}{2} \quad \text{and} \quad k = f\left(\frac{3}{2}\right) = -3\left(\frac{3}{2}\right)^2 + 9\left(\frac{3}{2}\right) + 4 = \frac{43}{4}$$

The vertex is  $\left(\frac{3}{2}, \frac{43}{4}\right)$ .

An important topic in calculus is optimizing functions; that is, finding a maximum and/or minimum value for the function. Precalculus students can use algebra to optimize quadratic functions. A quadratic function has a minimum value (if its graph opens up) or a maximum value (if its graph opens down). If  $a$  is positive, then  $k$  is the minimum functional value. If  $a$  is negative, then  $k$  is the maximum functional value. These values occur at  $x = h$ .

## EXAMPLES

Find the minimum or maximum functional value and where it occurs.

- $f(x) = -(x - 3)^2 + 25$

The parabola opens down because  $a = -1$  is negative. This means that  $k = 25$  is the maximum functional value. It occurs at  $x = 3$ .

- $y = 0.01x^2 - 6x + 2000$

$$h = \frac{-b}{2a} = \frac{-(-6)}{2(0.01)} = 300 \text{ and } k = 0.01(300)^2 - 6(300) + 2000 = 1100$$

$a = 0.01$  is positive, so  $k = 1100$  is the minimum functional value. The minimum occurs at  $x = 300$ .

## PRACTICE

For Problems 1–3, sketch the graph and identify the vertex and intercepts.

1.  $y = -(x - 1)^2 + 4$

2.  $f(x) = \frac{2}{3}(x + 1)^2 + 2$

3.  $y = -\frac{1}{2}x^2 - x + 12$

4. Rewrite  $f(x) = -\frac{3}{5}x^2 - 6x - 11$  in the form  $f(x) = a(x - h)^2 + k$ , using completing the square.

5. Find the maximum or minimum functional value for  $g(x) = -0.002x^2 + 5x + 150$ .

6. Find an equation for the quadratic function whose vertex is  $(2, 5)$  and whose graph contains the point  $(-8, 15)$ .

**SOLUTIONS**

1. The vertex is  $(1, 4)$ . The  $y$ -intercept is  $-(0 - 1)^2 + 4 = 3$ .

$$-(x - 1)^2 + 4 = 0$$

$$-(x - 1)^2 = -4$$

$$(x - 1)^2 = 4$$

$$(x - 1) = \pm 2$$

$$x = 1 \pm 2 = 1 + 2, 1 - 2 = 3, -1$$

The  $x$ -intercepts are 3 and  $-1$ .

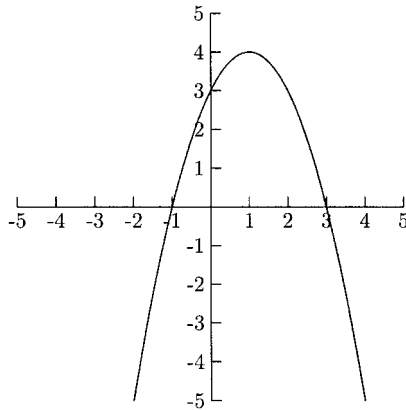

**Fig. 6.5.**

2. The vertex is  $(-1, 2)$ . The  $y$ -intercept is  $\frac{2}{3}(0 + 1) + 2 = \frac{8}{3}$ . There are two ways we can tell that there are no  $x$ -intercepts. The parabola opens up and the vertex is above the  $x$ -axis, so the parabola is always above the  $x$ -axis. Also, the equation  $\frac{2}{3}(x + 1)^2 + 2 = 0$  has no real number solution.

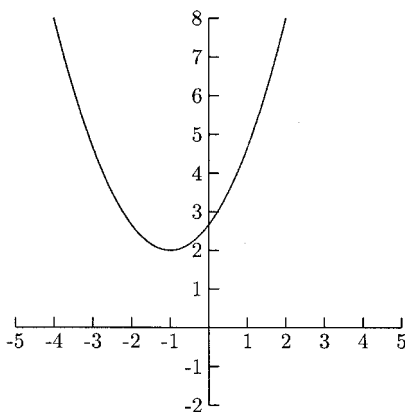

Fig. 6.6.

3. The vertex is  $(-1, \frac{25}{2})$ .

$$h = \frac{-b}{2a} = \frac{-(-1)}{2 \cdot \frac{-1}{2}} = -1 \text{ and } k = -\frac{1}{2}(-1)^2 - (-1) + 12 = \frac{25}{2}$$

The y-intercept is  $-\frac{1}{2}(0)^2 - 0 + 12 = 12$ .

$$0 = -\frac{1}{2}x^2 - x + 12$$

$$-2(0) = -2\left(-\frac{1}{2}x^2 - x + 12\right)$$

$$0 = x^2 + 2x - 24$$

$$0 = (x + 6)(x - 4)$$

$$x + 6 = 0$$

$$x = -6$$

$$x - 4 = 0$$

$$x = 4$$

The x-intercepts are  $-6$  and  $4$ .

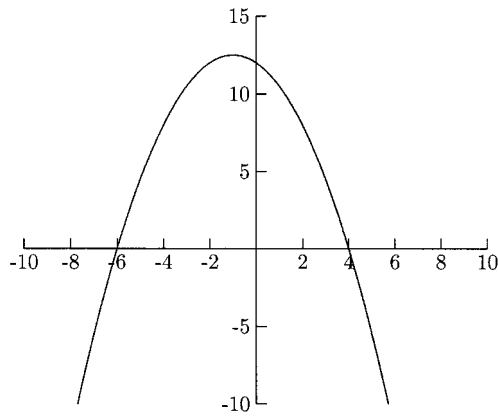

Fig. 6.7.

4.  $f(x) = -\frac{3}{5}x^2 - 6x - 11$

$$f(x) = -\frac{3}{5}(x^2 + 10x) - 11 \quad \frac{-6x}{-3/5} = -6x \div -\frac{3}{5} = -6x \cdot -\frac{5}{3} = 10x$$

$$f(x) = -\frac{3}{5}(x^2 + 10x + 25) - 11 + 15$$

$$f(x) = -\frac{3}{5}(x + 5)^2 + 4$$

5. This function has a maximum value because  $a = -0.002$  is negative. The answer is  $k$ .

$$h = \frac{-b}{2a} = \frac{-5}{2(-0.002)} = 1250 \text{ and}$$

$$k = g(1250) = -0.002(1250)^2 + 5(1250) + 150 = 3275$$

The maximum functional value is 3275.

6.  $h = 2, k = 5$  which makes  $y = a(x - h)^2 + k$  become  $y = a(x - 2)^2 + 5$ . We can find  $a$  by letting  $x = -8$  and  $y = 15$ .

$$y = a(x - 2)^2 + 5$$

$$15 = a(-8 - 2)^2 + 5$$

$$10 = a(-10)^2$$



$$10 = 100a$$

$$0.1 = a$$

The equation is  $y = 0.1(x - 2)^2 + 5$ .

These techniques to maximize/minimize quadratic functions can be applied to problems outside of mathematics. We can maximize the enclosed area, minimize the surface area of a box, maximize revenue, and optimize many other problems. In the first group of problems, the functions to be optimized will be given. In the second, we will have to find the functions based on the information given in the problem. The answers to every problem below will be one or both coordinates of the vertex.

## EXAMPLES

- The weekly profit function for a product is given by  $P(x) = -0.0001x^2 + 3x - 12,500$ , where  $x$  is the number of units produced per week, and  $P(x)$  is the profit (in dollars). What is the maximum weekly profit? How many units should be produced for this profit?

The profit function is a quadratic function which has a maximum value. What information does the vertex give us?  $h$  is the number of units needed to maximize the weekly profit, and  $k$  is the maximum weekly profit.

$$h = \frac{-b}{2a} = \frac{-3}{2(-0.0001)} = 15,000 \text{ and}$$

$$k = -0.0001(15,000)^2 + 3(15,000) - 12,500 = 10,000$$

Maximize the weekly profit by producing 15,000 units. The maximum weekly profit is \$10,000.

- The number of units of a product sold depends on the amount of money spent on advertising. If  $y = -26x^2 + 2600x + 10,000$  gives the number of units sold after  $x$  thousands of dollars is spent on advertising, find the amount spent on advertising that results in the most sales.

$h$  will give us the amount to spend on advertising in order to maximize sales, and  $k$  will tell us the maximum sales level. We only need to find  $h$ .

$$h = \frac{-b}{2a} = \frac{-2600}{2(-26)} = 50$$

\$50 thousand should be spent on advertising to maximize sales.

The height of an object propelled upward (neglecting air resistance) is given by the quadratic function  $s(t) = -16t^2 + v_0t + s_0$ , where  $s$  is the height in feet, and

$t$  is the number of seconds after the initial thrust. The initial velocity (in feet per second) of the object is  $v_0$ , and  $s_0$  is the initial height (in feet) of the object. For example, if an object is tossed up at the rate of 10 feet per second, then  $v_0 = 10$ . If an object is propelled upward from a height of 50 feet, then  $s_0 = 50$ . If an object is dropped, its initial velocity is 0, so  $v_0 = 0$ .

## EXAMPLES

- An object is tossed upward with an initial velocity of 15 feet per second from a height of four feet. What is the object's maximum height? How long does it take the object to reach its maximum height?

Because the initial velocity is 15 feet per second,  $v_0 = 15$ , and the initial height is four feet, so  $s_0 = 4$ . The function that gives the height of the object (in feet) after  $t$  seconds is  $s(t) = -16t^2 + 15t + 4$ .

$$h = \frac{-b}{2a} = \frac{-15}{2(-16)} = 0.46875 \text{ and}$$

$$k = -16(0.46875)^2 + 15(0.46875) + 4 = 7.515625$$

The object reaches its maximum height of 7.515625 feet after 0.46875 seconds.

- A projectile is fired from the ground with an initial velocity of 120 miles per hour. What is the projectile's maximum height? How long does it take to reach its maximum height?

Because the projectile is being fired from the ground, its initial height is 0, so  $s_0 = 0$ . The initial velocity is given as 120 miles per hour—we need to convert this to feet per second. There are 5280 feet per mile, so 120 miles is  $120(5280) = 633,600$  feet. There are  $60(60) = 3600$  seconds per hour.

$$\frac{120 \text{ miles}}{1 \text{ hour}} = \frac{633,600 \text{ feet}}{3600 \text{ seconds}} = 176 \text{ feet per second}$$

Now we have the function:  $s(t) = -16t^2 + 176t + 0 = -16t^2 + 176t$ .

$$h = \frac{-b}{2a} = \frac{-176}{2(-16)} = 5.5 \text{ and } k = -16(5.5)^2 + 176(5.5) = 484$$

The projectile reaches its maximum height of 484 feet after 5.5 seconds.

Another problem involving the maximum vertical height is one where we know the horizontal distance traveled instead of the time it has traveled. The  $x$ -coordinates describe the object's horizontal distance, and the  $y$ -coordinates describe its height. Here we will find the maximum height and how far it traveled horizontally to reach the maximum height.

**EXAMPLE**

- A ball is thrown across a field. Its path can be described by the equation  $y = -0.002x^2 + 0.2x + 5$ , where  $x$  is the horizontal distance (in feet) and  $y$  is the height (in feet). See Figure 6.8. What is the ball's maximum height? How far had it traveled horizontally to reach its maximum height?

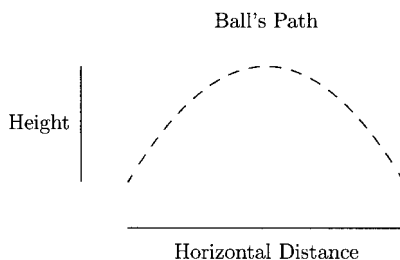
**Fig. 6.8.**

$k$  will answer the first question, and  $h$  will answer the second.

$$h = \frac{-b}{2a} = \frac{-0.2}{2(-0.002)} = 50 \text{ and } k = -0.002(50)^2 + 0.2(50) + 5 = 10$$

The ball reached a maximum height of 10 feet when it traveled 50 feet horizontally.

The revenue of a product or service can depend on its price in two ways. An increase in the price means that more revenue per unit is earned but fewer units are sold. A decrease in the price means that less revenue is earned per unit but more units are sold. Quadratic functions model some of these relationships. In the next problems, a current price and sales level are given. We will be told how a price increase or decrease affects the sales level. We will let  $x$  represent the number of price increases/decreases. Suppose every \$10 decrease in the price results in an increase of five customers. Then the revenue function is  $(\text{old price} - 10x)(\text{old sales level} + 5x)$ . If every \$50 increase in the price results in a loss of one customer, then the revenue function is  $(\text{old price} + 50x)(\text{old sales level} - 1x)$ . These functions are quadratic functions which have a maximum value. The vertex tells us the maximum revenue and how many times to decrease/increase the price to get the maximum revenue.

**EXAMPLES**

- A management firm has determined that 60 apartments in a complex can be rented if the monthly rent is \$900, and that for each \$50 increase

in the rent, three tenants are lost with little chance of being replaced. What rent should be charged to maximize revenue? What is the maximum revenue?

Let  $x$  represent the number of \$50 increases in the rent. This means if the rent is raised \$50,  $x = 1$ , if the rent is increased \$100,  $x = 2$ , and if the rent is increased \$150,  $x = 3$ . The rent function is  $900 + 50x$ . The number of tenants depends on the number of \$50 increases in the rent. So, if the rent is raised \$50, there will be  $60 - 3(1)$  tenants; if the rent is raised \$100, there will be  $60 - 3(2)$  tenants; and if the rent is raised \$150, there will be  $60 - 3(3)$  tenants. If the rent is raised \$50 $x$ , there will be  $60 - 3x$  tenants. The revenue function is

$$R = (900 + 50x)(60 - 3x) = -150x^2 + 300x + 54,000.$$

$$h = \frac{-b}{2a} = \frac{-300}{2(-150)} = 1 \text{ and } k = -150(1)^2 + 300(1) + 54,000 = 54,150$$

The maximum revenue is \$54,150. Maximize revenue by charging  $900 + 50(1) = \$950$  per month for rent.

- A cinema multiplex averages 2500 tickets sold on a Saturday when ticket prices are \$8. Concession revenue averages \$1.50 per ticket sold. A research firm has determined that for each \$0.50 increase in the ticket price, 100 fewer tickets will be sold. What is the maximum revenue (including concession revenue) and what ticket price maximizes the revenue?

Let  $x$  represent the number of \$0.50 increases in the price. The ticket price is  $8 + 0.50x$ . The average number of tickets sold is  $2500 - 100x$ . The average ticket revenue is  $(8.00 + 0.50x)(2500 - 100x)$ . The average concession revenue is  $1.50(2500 - 100x)$ . The total revenue is

$$\begin{aligned} R &= (8.00 + 0.50x)(2500 - 100x) + 1.50(2500 - 100x) \\ &= -50x^2 + 300x + 23,750. \end{aligned}$$

$$h = \frac{-b}{2a} = \frac{-300}{2(-50)} = 3 \text{ and } k = -50(3)^2 + 300(3) + 23,750 = 24,200$$

To maximize revenue, the ticket price should be  $8.00 + 0.50(3) = \$9.50$ , and the maximum revenue is \$24,200.

- The manager of a performing arts company offers a group discount price of \$45 per person for groups of 20 or more and will drop the price by \$1.50 per person for each additional person. What is the maximum revenue? What size group will maximize the revenue?

Because the price does not change until more than 20 people are in the group, we will let  $x$  represent the additional people in the group. What is the price per person if the group size is more than 20? If one extra person is in the group, the price is  $45 - 1(1.50)$ . If there are two extra people, the price is  $45 - 2(1.50)$ ; and if there are three extra people, the price is  $45 - 3(1.50)$ . So, if there are  $x$  additional people, the price is  $45 - 1.50x$ . The revenue is

$$R = (20 + x)(45 - 1.50x) = -1.50x^2 + 15x + 900.$$

$$h = \frac{-b}{2a} = \frac{-15}{2(-1.50)} = 5 \text{ and } k = -1.50(5)^2 + 15(5) + 900 = 937.50$$

The group size that maximizes revenue is  $20 + 5 = 25$ . The maximum revenue is \$937.50.

Optimizing geometric figures are common calculus and precalculus problems. In many of these problems, there are more than two variables. We will be given enough information in the problem to eliminate one of the variables. For example, if we want the area of a rectangle, the formula is  $A = LW$ . If we know the perimeter is 20, then we can use the equation  $2L + 2W = 20$  to solve for either  $L$  or  $W$  and substitute this quantity in the area function, reducing the equation from three to two variables. The new area function will be quadratic.

## EXAMPLES

- A parks department has 1200 meters of fencing available to enclose two adjacent playing fields. (See Figure 6.9.) What dimensions will maximize the enclosed area? What is the maximum enclosed area?

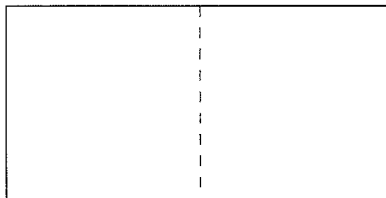

Fig. 6.9.

The total enclosed area is  $A = LW$ . Because there is 1200 meters of fencing available, we must have  $L + W + W + W + L = 1200$  (see Figure 6.10).

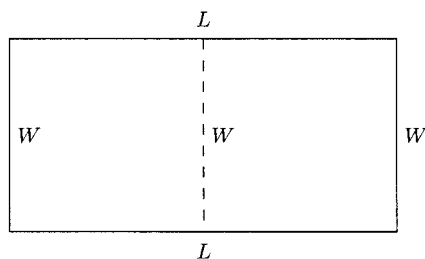

Fig. 6.10.

We can solve for  $L$  or  $W$  in this equation and substitute it in  $A = LW$ , reducing the equation to two variables. We will solve for  $L$  in  $2L + 3W = 1200$ .

$$2L + 3W = 1200$$

$$L = \frac{1200 - 3W}{2}$$

Now  $A = LW$  becomes  $A = \frac{1200-3W}{2} \cdot W = -\frac{3}{2}W^2 + 600W$ . This function has a maximum value.

$$h = \frac{-b}{2a} = \frac{-600}{2(-3/2)} = 200 \text{ and } k = -\frac{3}{2}(200)^2 + 600(200) = 60,000$$

The width that maximizes the enclosed area is 200 meters, the length is  $\frac{1200-3(200)}{2} = 300$  meters. The maximum enclosed area is 60,000 square meters.

Another common fencing problem is one where only three sides of a rectangular area needs to be fenced. The fourth side is some other boundary like a stream or the side of a building. We will call two sides  $W$  and the third side  $L$ . Then “ $2W + L =$  amount of fencing” allows us to solve for  $L$  and substitute “ $L =$  amount of fencing  $-2W$ ” in  $A = LW$  to reduce the area formula to two variables.

## EXAMPLE

- A farmer has 1000 feet of fencing materials available to fence a rectangular pasture next to a river. If the side along the river does not need to be fenced, what dimensions will maximize the enclosed area? What is the maximum enclosed area?

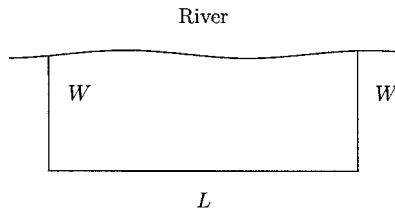

Fig. 6.11.

Using the fact that  $2W + L = 1000$ , we can solve for  $L$  and substitute this quantity in the area formula  $A = LW$ .

$$2W + L = 1000$$

$$L = 1000 - 2W$$

$$A = LW$$

$$A = (1000 - 2W)W = -2W^2 + 1000W$$

This quadratic function has a maximum value.

$$h = \frac{-b}{2a} = \frac{-1000}{2(-2)} = 250 \text{ and } k = -2(250)^2 + 1000(250) = 125,000$$

Maximize the enclosed area by letting  $W = 250$  feet and  $L = 1000 - 2(250) = 500$  feet. The maximum enclosed area is 125,000 square feet.

In the last problems, we will maximize the area of a figure but will have to work a little harder to find the area function to maximize.

## EXAMPLES

- A window is to be constructed in the shape of a rectangle surmounted by a semicircle (see Figure 6.12). The perimeter of the window needs to be 18 feet. What dimensions will admit the greatest amount of light?

The dimensions that will admit the greatest amount of light are the same that will maximize the area of the window. The area of the window is the rectangular area plus the area of the semicircle. The area of the rectangular region is  $LW$ . Because the width of the window is the diameter (or twice the

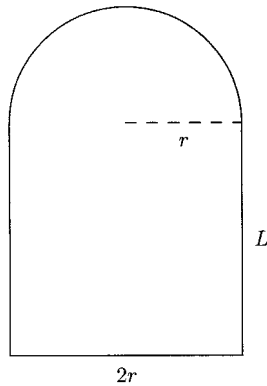

Fig. 6.12.

radius) of the semicircle, we can rewrite the area as  $L(2r) = 2rL$ . The area of the semicircle is half of the area of a circle with radius  $r$ , or  $\frac{1}{2}\pi r^2$ . The total area of the window is

$$A = 2rL + \frac{1}{2}\pi r^2.$$

Now we will use the fact that the perimeter is 18 feet to help us replace  $L$  with an expression using  $r$ . The perimeter is made up of the two sides ( $2L$ ) and the bottom of the rectangle ( $2r$ ) and the length around the semicircle. The length around the outside of the semicircle is half of the circumference of a circle with radius  $r$ ,  $\frac{1}{2}(2\pi r) = \pi r$ . The total perimeter is  $P = 2L + 2r + \pi r$ . This is equal to 18. We will solve the equation  $2L + 2r + \pi r = 18$  for  $L$ .

$$2L + 2r + \pi r = 18$$

$$2L = 18 - 2r - \pi r$$

$$L = \frac{18 - 2r - \pi r}{2} = 9 - r - \frac{1}{2}\pi r$$

Now we will substitute  $9 - r - \frac{1}{2}\pi r$  for  $L$  in the area formula.

$$A = 2rL + \frac{1}{2}\pi r^2$$

$$A = 2r(9 - r - \frac{1}{2}\pi r) + \frac{1}{2}\pi r^2$$



$$A = 18r - 2r^2 - \pi r^2 + \frac{1}{2}\pi r^2 = 18r - 2r^2 - \frac{1}{2}\pi r^2 = 18r - \left(2 + \frac{1}{2}\pi\right)r^2$$

$$A = -\left(2 + \frac{1}{2}\pi\right)r^2 + 18r$$

This quadratic function has a maximum value.

$$h = \frac{-b}{2a} = \frac{-18}{2\left[-\left(2 + \frac{1}{2}\pi\right)\right]} = \frac{18}{4 + \pi} \approx 2.52$$

Maximize the amount of light admitted in the window by letting the radius of the semicircle be about 2.52 feet, and the length about  $9 - 2.52 - \frac{\pi}{2}(2.52) \approx 2.52$  feet.

- A track is to be constructed so that it is shaped like Figure 6.13, a rectangle with a semicircle at each end. If the inside perimeter of the track is to be  $\frac{1}{4}$  mile, what is the maximum area of the rectangle?

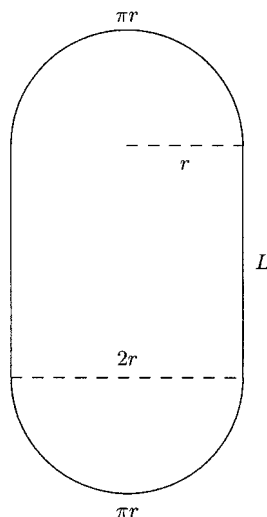

Fig. 6.13.

The length of the rectangle is  $L$ . Its width is the diameter of the semicircles (or twice their radius). The area formula for the rectangle is  $A = LW = L(2r) = 2rL$ . The perimeter of the figure is the two sides of the rectangle ( $2L$ ) plus the length around each semicircle ( $\pi r$ ). The total perimeter is  $2L + 2\pi r$ . Although we could work with the dimensions in miles, it will be easier to convert  $1/4$  mile to feet. There are  $5280/4 = 1320$  feet in  $1/4$  mile.

We will solve  $2L + 2\pi r = 1320$  for  $L$ . Solving for  $r$  works, too.

$$2L + 2\pi r = 1320$$

$$2L = 1320 - 2\pi r$$

$$L = \frac{1320 - 2\pi r}{2} = 660 - \pi r$$

$$A = 2rL$$

$$A = 2r(660 - \pi r) = -2\pi r^2 + 1320r$$

The area function has a maximum value.

$$h = \frac{-b}{2a} = \frac{-1320}{2(-2\pi)} = \frac{330}{\pi}$$

$$\begin{aligned} k &= -2\pi \left(\frac{330}{\pi}\right)^2 + 1320 \left(\frac{330}{\pi}\right) \\ &= \frac{217,800}{\pi} \approx 69,328 \end{aligned}$$

The maximum area of the rectangular region is about 69,328 square feet.

- A rectangle is to be constructed so that it is bounded below by the  $x$ -axis, on the left by the  $y$ -axis, and above by the line  $y = -2x + 12$ . (See Figure 6.14). What is the maximum area of the rectangle?

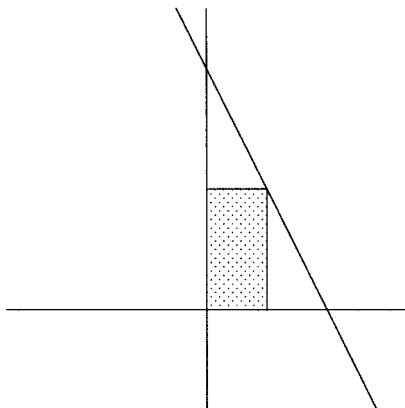

Fig. 6.14.

The coordinates of the corners will help us to see how we can find the length and width of the rectangle.

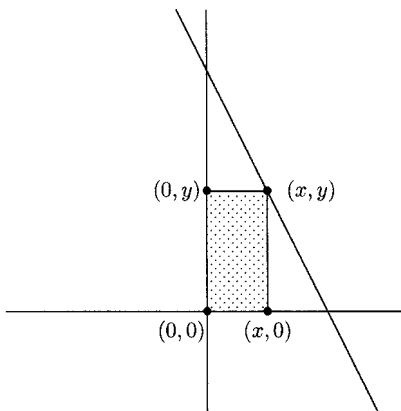

Fig. 6.15.

The height of the rectangle is  $y$  and the width is  $x$ . This makes the area  $A = xy$ . We need to eliminate  $x$  or  $y$ . Because  $y = -2x + 12$ , we can substitute  $-2x + 12$  for  $y$  in  $A = xy$  to make it the quadratic function  $A = xy = x(-2x + 12) = -2x^2 + 12x$ .

$$h = \frac{-b}{2a} = \frac{-12}{2(-2)} = 3 \text{ and } k = -2(3)^2 + 12(3) = 18$$

The maximum area is 18 square units.

## PRACTICE

1. The average cost of a product can be approximated by the function  $C(x) = 0.00025x^2 - 0.25x + 70.5$ , where  $x$  is the number of units produced and  $C(x)$  is the average cost in dollars. What level of production will minimize the average cost?
2. A frog jumps from a rock to the shore of a pond. Its path is given by the equation  $y = -\frac{5}{72}x^2 + \frac{5}{3}x$ , where  $x$  is the horizontal distance in inches, and  $y$  is the height in inches. What is the frog's maximum height? How far had it traveled horizontally when it reached its maximum height?

3. A projectile is fired upward from a ten-foot platform. The projectile's initial velocity is 108 miles per hour. What is the projectile's maximum height? When will it reach its maximum height?
4. Attendance at home games for a college basketball team averages 1000 and the ticket price is \$12. Concession sales average \$2 per person. A student survey reveals that for every \$0.25 decrease in the ticket price, 25 more students will attend the home games. What ticket price will maximize revenue? What is the maximum revenue?
5. A school has 1600 feet of fencing available to enclose three playing fields (see Figure 6.16). What dimensions will maximize the enclosed area?

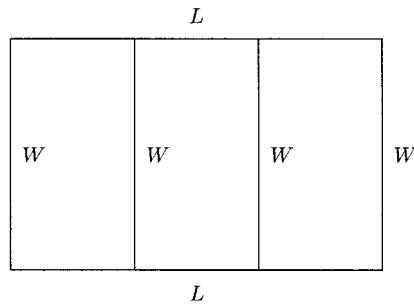

Fig. 6.16.

6. The manager of a large warehouse wants to enclose an area behind the building. He has 900 feet of fencing available. What dimensions will maximize the enclosed area? What is the maximum area?

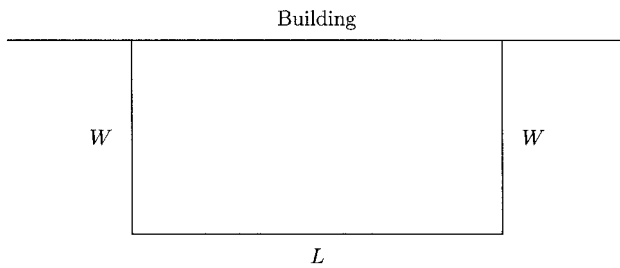

Fig. 6.17.

7. A swimming pool is to be constructed in the shape of a rectangle with a semicircle at one end (see Figure 6.12). If the perimeter is to be 120 feet, what dimensions will maximize the area? What is the maximum area?

8. A rectangle is to be constructed so that it is bounded by the  $x$ -axis, the  $y$ -axis, and the line  $y = -3x + 4$  (see Figure 6.18). What is the maximum area of the rectangle?

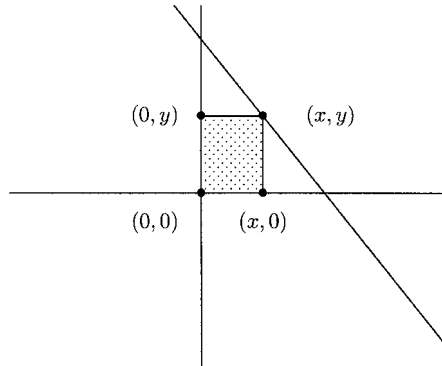

Fig. 6.18.

## SOLUTIONS

1. We only need to find  $h$ .

$$h = \frac{-b}{2a} = \frac{-(-0.25)}{2(0.00025)} = 500$$

Minimize the average cost by producing 500 units.

2.  $k$  answers the first question,  $h$  answers the second.

$$h = \frac{-b}{2a} = \frac{-5/3}{2(-5/72)} = \frac{5/3}{5/36} = \frac{5}{3} \div \frac{5}{36} = \frac{5}{3} \cdot \frac{36}{5} = 12$$

$$k = -\frac{5}{72}(12)^2 + \frac{5}{3}(12) = 10$$

The frog reached a maximum height of 10 inches and had traveled 12 inches horizontally when it reached its maximum height.

3. The formula  $s(t) = -16t^2 + v_0t + s_0$  is in feet and seconds, so we need to convert 108 miles per hour to feet per second. There are 5280 feet in a mile and  $60(60) = 3600$  seconds in an hour.

$$\frac{108 \text{ miles}}{1 \text{ hour}} = \frac{108(5280) \text{ feet}}{3600 \text{ seconds}} = 158.4 \text{ feet per second}$$

Replacing  $v_0$  with 158.4 and  $s_0$  with 10, we have the function giving the height of the projectile after  $t$  seconds,  $s(t) = -16t^2 + 158.4t + 10$ .

$$h = \frac{-b}{2a} = \frac{-158.4}{2(-16)} = 4.95 \text{ and}$$

$$k = -16(4.95)^2 + 158.4(4.95) + 10 = 402.04$$

The projectile reaches a maximum height of 402.04 feet after 4.95 seconds.

4. We will let  $x$  represent the number of \$0.25 decreases in the ticket price. The ticket price is  $12 - 0.25x$  and the average number attending the games is  $1000 + 25x$ . Ticket revenue is  $(12 - 0.25x)(1000 + 25x)$ . Revenue from concession sales is  $2(1000 + 25x)$ . Total revenue is

$$R = (12 - 0.25x)(1000 + 25x) + 2(1000 + 25x)$$

$$= -6.25x^2 + 100x + 14,000$$

$$h = \frac{-b}{2a} = \frac{-100}{2(-6.25)} = 8 \text{ and}$$

$$k = -6.25(8)^2 + 100(8) + 14,000 = 14,400$$

The ticket price that will maximize revenue is  $12 - 0.25(8) = \$10$  and the maximum revenue is \$14,400.

5. The total area is  $A = LW$ . Because there is 1600 feet of fencing available,  $2L + 4W = 1600$ . Solving this equation for  $L$ , we have  $L = 800 - 2W$ . Substitute  $800 - 2W$  for  $L$  in  $A = LW$ .

$$A = LW$$

$$= (800 - 2W)W = -2W^2 + 800W$$

$$h = \frac{-b}{2a} = \frac{-800}{2(-2)} = 200$$

Maximize the enclosed area by letting the width be 200 feet and the length be  $800 - 2(200) = 400$  feet.

6. The enclosed area is  $A = LW$ . Because 900 feet of fencing is available,  $2W + L = 900$ . Solving this for  $L$ , we have  $L = 900 - 2W$ . We will substitute  $900 - 2W$  for  $L$  in  $A = LW$ .

$$A = LW$$

$$= (900 - 2W)W = -2W^2 + 900W$$

$$h = \frac{-b}{2a} = \frac{-900}{2(-2)} = 225 \text{ and } k = -2(225)^2 + 900(225) = 101,250$$

Maximize the enclosed area by letting the width be 225 feet and the length  $900 - 2(225) = 450$  feet. The maximum enclosed area is 101,250 square feet.

7. The area of the rectangle is  $2rL$  (the width is twice the radius of the semicircle). The area of the semicircle is half the area of a circle with radius  $r$ ,  $\frac{1}{2}\pi r^2$ . The total area of the pool is  $A = 2rL + \frac{1}{2}\pi r^2$ . After finding an equation for the perimeter, we will solve the equation for  $L$  and substitute this for  $L$  in  $A = 2rL + \frac{1}{2}\pi r^2$ . The perimeter of the rectangular part is  $L + 2r + L = 2r + 2L$ . The length around the semicircle is half the circumference of a circle with radius  $r$ ,  $\frac{1}{2}(2\pi r) = \pi r$ . The total length around the pool is  $2L + 2r + \pi r$  which equals 120 feet.

$$2L + 2r + \pi r = 120$$

$$2L = 120 - 2r - \pi r$$

$$L = \frac{120 - 2r - \pi r}{2} = 60 - r - \frac{1}{2}\pi r$$

$$A = 2rL + \frac{1}{2}\pi r^2$$

$$= 2r(60 - r - \frac{1}{2}\pi r) + \frac{1}{2}\pi r^2 \text{ Substitute } 60 - r - \frac{1}{2}\pi r \text{ for } L.$$

$$= 120r - 2r^2 - \pi r^2 + \frac{1}{2}\pi r^2$$

$$= -2r^2 - \frac{1}{2}\pi r^2 + 120r$$

$$= \left(-2 - \frac{1}{2}\pi\right)r^2 + 120r$$

$$h = \frac{-b}{2a} = \frac{-120}{2(-2 - \frac{1}{2}\pi)} = \frac{-120}{-4 - \pi} = \frac{-120}{-(4 + \pi)}$$

$$= \frac{120}{4 + \pi} \approx 16.8$$

$$\begin{aligned}
 k &= \left(-2 - \frac{1}{2}\pi\right) \left(\frac{120}{4 + \pi}\right)^2 + 120 \left(\frac{120}{4 + \pi}\right) \\
 &= \frac{7200}{4 + \pi} \approx 1008.2
 \end{aligned}$$

Maximize the area by letting the radius of the semicircle be about 16.8 feet and the length of the rectangle about  $60 - 16.8 - \frac{1}{2}\pi(16.8) \approx 16.8$  feet. The maximum area is about 1008.2 square feet.

8. The area is  $A = LW$ . The length of the rectangle is  $y$  (the distance from  $(0, 0)$  and  $(0, y)$ ). The width is  $x$  (the distance from  $(0, 0)$  and  $(x, 0)$ ). The area is now  $A = xy$ . Because  $y = -3x + 4$ , we can substitute  $-3x + 4$  for  $y$  in  $A = xy$ .

$$A = xy$$

$$A = x(-3x + 4) = -3x^2 + 4x$$

$$h = \frac{-4}{2(-3)} = \frac{2}{3} \text{ and } k = -3\left(\frac{2}{3}\right)^2 + 4\left(\frac{2}{3}\right) = \frac{4}{3}$$

The maximum area is  $\frac{4}{3}$  square units.

## CHAPTER 6 REVIEW

- What is the vertex for  $f(x) = -2(x - 1)^2 + 4$ ?  
 (a)  $(1, 4)$       (b)  $(-1, 4)$       (c)  $(-2, 4)$       (d)  $(2, 4)$
- Complete the square on  $y = x^2 - 6x + 10$  to write it in the form  $y = a(x - h)^2 + k$ .  
 (a)  $y = (x - 3)^2 + 9$       (b)  $y = (x - 3)^2 + 19$   
 (c)  $y = (x - 3)^2 - 9$       (d)  $y = (x - 3)^2 + 1$
- Complete the square on  $y = 3x^2 - x + 1$  to write it in the form  $y = a(x - h)^2 + k$ .  
 (a)  $y = 3\left(x - \frac{1}{6}\right)^2 + \frac{13}{12}$       (b)  $y = 3\left(x - \frac{1}{6}\right)^2 + \frac{11}{12}$   
 (c)  $y = 3\left(x - \frac{1}{6}\right)^2 + \frac{35}{36}$       (d)  $y = 3\left(x - \frac{1}{6}\right)^2 + \frac{37}{36}$



4. What are the  $x$ - and  $y$ -intercepts for  $f(x) = 2x^2 + x - 6$ ?
- The  $y$ -intercept is  $-6$ , and the  $x$ -intercepts are  $-\frac{3}{2}$  and  $2$ .
  - The  $y$ -intercept is  $-6$ , and the  $x$ -intercepts are  $\frac{3}{2}$  and  $2$ .
  - The  $y$ -intercept is  $-6$ , and the  $x$ -intercepts are  $\frac{3}{2}$  and  $-2$ .
  - The  $y$ -intercept is  $-6$ , and the  $x$ -intercepts are  $-\frac{3}{2}$  and  $-2$ .
5. What is the vertex for  $f(x) = -0.02x^2 + 3x - 10$ ?
- $(75, -122.5)$
  - $(-75, -347.5)$
  - $(75, 102.5)$
  - $(75, 5615)$
6. Find the maximum or minimum functional value for  $f(x) = 6(x - 25)^2 + 100$ .
- The maximum functional value is  $25$ .
  - The maximum functional value is  $100$ .
  - The minimum functional value is  $25$ .
  - The minimum functional value is  $100$ .
7. Find the quadratic function with vertex  $(4, -2)$  and with the point  $(5, -\frac{5}{3})$  on its graph.
- $f(x) = \frac{1}{3}(x - 4)^2 - 2$
  - $f(x) = \frac{1}{27}(x + 4)^2 - 2$
  - $f(x) = (x - 4)^2 + 2$
  - $f(x) = -\frac{1}{81}(x + 4)^2 + 2$

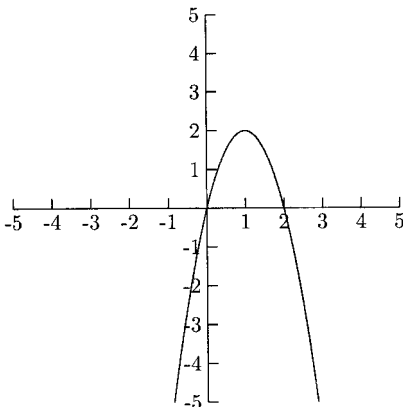

Fig. 6.19.

8. What is the function whose graph is in Figure 6.19?
- $f(x) = -2(x + 1)^2 + 2$
  - $f(x) = -2(x - 1)^2 + 2$
  - $f(x) = 2(x + 1)^2 + 2$
  - $f(x) = 2(x - 1)^2 + 2$

9. A hot dog vendor at a local fair averages 140 hot dogs per day when the price is \$3. If for every \$0.25 increase in the price, 10 fewer hot dogs are sold on average, what price maximizes the revenue?
- (a) \$3.00      (b) \$3.25      (c) \$3.50      (d) \$3.75
10. A warehouse manager wants to fence a rectangular area behind his warehouse. He has 120 meters of fencing available. If the side against the building does not need to be fenced, what is the maximum enclosed area?
- (a) 1500 square meters      (b) 1700 square meters  
(c) 1600 square meters      (d) 1800 square meters

### SOLUTIONS

1. A      2. D      3. B      4. C      5. C  
6. D      7. A      8. B      9. B      10. D



## CHAPTER

# Polynomial Functions

A polynomial function is a function in the form  $f(x) = a_nx^n + a_{n-1}x^{n-1} + \dots + a_1x + a_0$ , where each  $a_i$  is a real number and the powers on  $x$  are whole numbers. There is no  $x$  under a root sign and no  $x$  in a denominator. The number  $a_i$  is called a *coefficient*. For example, in the polynomial function  $f(x) = -2x^3 + 5x^2 - 4x + 8$ , the coefficients are  $-2$ ,  $5$ ,  $-4$ , and  $8$ . The *constant* term (the term with no variable) is  $8$ . The powers on  $x$  are  $3$ ,  $2$ , and  $1$ . The *degree* of the polynomial (and polynomial function) is the highest power on  $x$ . In this example, the degree is  $3$ . Quadratic functions are degree  $2$ . Linear functions of the form  $f(x) = mx + b$  (if  $m \neq 0$ ) are degree  $1$ . Constant functions of the form  $f(x) = b$  are degree  $0$  (this is because  $x^0 = 1$ , making  $f(x) = bx^0$ ).

The *leading term* of a polynomial (and polynomial function) is the term having  $x$  to the highest power. Usually, but not always, the leading term is written first. The *leading coefficient* is the coefficient on the leading term. In our example, the leading term is  $-2x^3$ , and the leading coefficient is  $-2$ . By looking at the leading term only, we can tell roughly what the graph looks like. The graph of any polynomial will

XI

either go up on both ends, go down on both ends, or go up on one end and down on the other. This is called the *end behavior* of the graph. The figures below illustrate the end behavior of polynomial functions. The shape of the dashed part of the graph depends on the individual function.

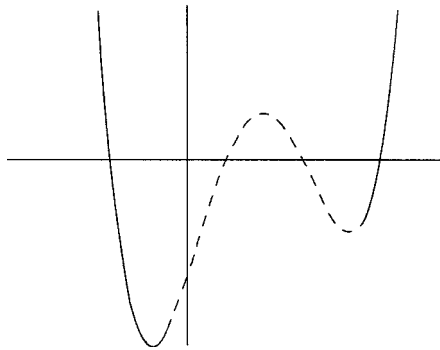

**Fig. 7.1.**

This graph goes up on both ends.

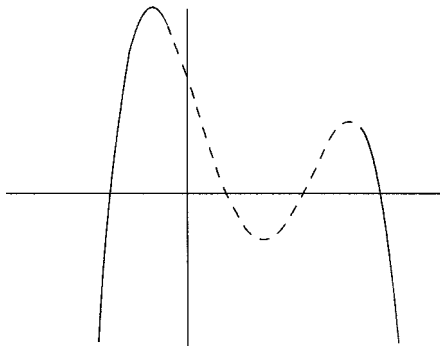

**Fig. 7.2.**

This graph goes down on both ends.

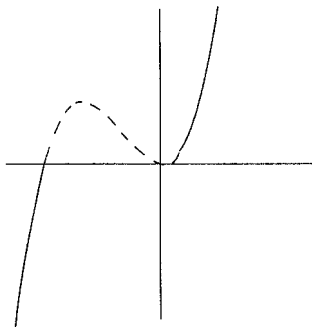

**Fig. 7.3.**

This graph goes down on the left and up on the right.

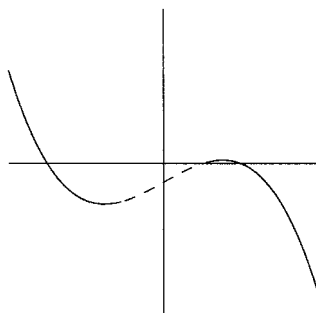

Fig. 7.4.

This graph goes up on the left and down on the right.

If the degree of the polynomial is an even number, the graph will look like the graph in Figure 7.1 or in Figure 7.2. If the leading coefficient is a positive number, the graph will look like the graph in Figure 7.1. If the leading coefficient is a negative number, the graph will look like the graph in Figure 7.2. If the degree of the polynomial is an odd number, the graph will look like the one in Figure 7.3 or in Figure 7.4. If the leading coefficient is a positive number, the graph will look like the graph in Figure 7.3. If the leading coefficient is a negative number, the graph will look like the graph in Figure 7.4.

How can one term in a polynomial function give us this information? For polynomial functions, the leading term dominates all of the other terms. For  $x$ -values large enough (both large positive numbers and large negative numbers), the other terms don't contribute much to the size of the  $y$ -values.

## EXAMPLES

Match the graph of the given function with one of the graphs in Figures 7.1–7.4.

- $f(x) = 4x^5 + 6x^3 - 2x^2 + 8x + 11$

We only need to look at the leading term,  $4x^5$ . The degree, 5, is odd, and the leading coefficient, 4, is positive. The graph of this function looks like the one in Figure 7.3.

- $P(x) = 5 + 2x - 6x^2$

The leading term is  $-6x^2$ . The degree, 2, is even, and the leading coefficient,  $-6$ , is negative. The graph of this function looks like the one in Figure 7.2.

- $h(x) = -2x^3 + 4x^2 - 7x + 9$

The leading term is  $-2x^3$ . The degree, 3, is odd, and the leading coefficient,  $-2$ , is negative. The graph of this function looks like the one in Figure 7.4.

- $g(x) = x^4 + 4x^3 - 8x^2 + 3x - 5$

The leading term is  $x^4$ . The degree, 4, is even, and the leading coefficient, 1, is positive. The graph of this function looks like the one in Figure 7.1.

Finding the  $x$ -intercepts (if any) for the graph of a polynomial function is very important. The  $x$ -intercept of any graph is where the graph touches the  $x$ -axis. This happens when the  $y$ -coordinate of the point is 0. We found the  $x$ -intercepts for some quadratic functions by factoring and setting each factor equal to zero. This is how we will find the  $x$ -intercepts for polynomial functions. It is not always easy to do. In fact, some polynomials are so hard to factor that the best we can do is approximate the  $x$ -intercepts (using graphing calculators or calculus). This will not be the case for the polynomials in this book, however. Every polynomial here will be factorable using techniques covered later.

Because an  $x$ -intercept for  $f(x) = a_nx^n + a_{n-1}x^{n-1} + \cdots + a_1x + a_0$  is a solution to the equation  $0 = a_nx^n + a_{n-1}x^{n-1} + \cdots + a_1x + a_0$ ,  $x$ -intercepts are also called *zeros* of the polynomial. All of the following statements have the same meaning for a polynomial. Let  $c$  be a real number, and let  $P(x)$  be a polynomial function.

1.  $c$  is an  $x$ -intercept of the graph of  $P(x)$ .
2.  $c$  is a zero for  $P(x)$ .
3.  $x - c$  is a factor of  $P(x)$ .

## EXAMPLES

- $x - 1$  is a factor means that 1 is an  $x$ -intercept and a zero.
- $x + 5$  is a factor means that  $-5$  is an  $x$ -intercept and a zero.
- $x$  is a factor means that 0 is an  $x$ -intercept and a zero.
- 3 is a zero means that  $x - 3$  is a factor and 3 is an  $x$ -intercept.

We can find the zeros of a function (or at least the approximate zeros) by looking at its graph.

The  $x$ -intercepts of the graph in Figure 7.5 are 2 and  $-2$ . Now we know that  $x - 2$  and  $x + 2$  (which is  $x - (-2)$ ) are factors of the polynomial.

The graph of the polynomial function in Figure 7.6 has  $x$ -intercepts of  $-1$ , 1, and 2. This means that  $x - 1$ ,  $x - 2$ , and  $x + 1$  (as  $x - (-1)$ ) are factors of the polynomial.

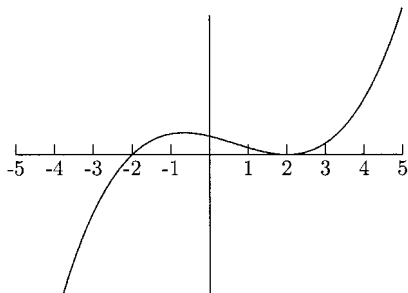

Fig. 7.5.

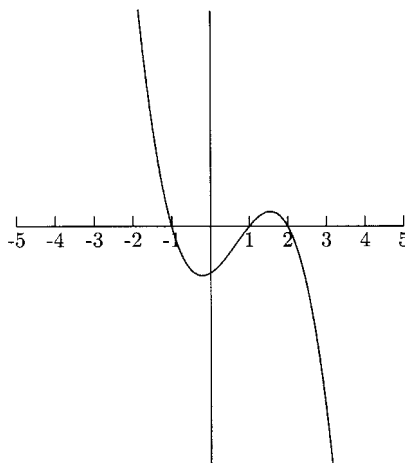

Fig. 7.6.

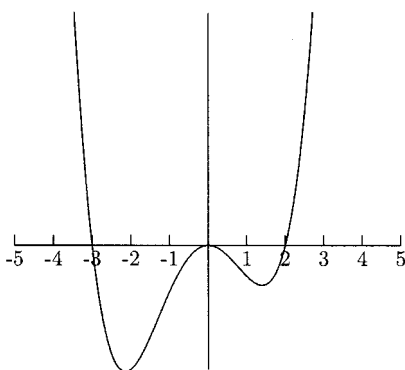

Fig. 7.7.

The  $x$ -intercepts for the graph in Figure 7.7 are  $-3$ ,  $0$ , and  $2$ , making  $x + 3$ ,  $x$  (as  $x - 0$ ), and  $x - 2$  factors of the polynomial.

Now that we know about the end behavior of the graphs of polynomial functions and the relationship between  $x$ -intercepts and factors, we can look at a polynomial and have a pretty good idea of what its graph looks like. In the next set of examples, we will match the graphs from the previous section with their polynomial functions.

## EXAMPLES

Match the functions with the graphs in Figures 7.5–7.7.

- $f(x) = \frac{1}{10}x^2(x + 3)(x - 2) = \frac{1}{10}x^4 + \frac{1}{10}x^3 - \frac{3}{5}x^2$

Because  $f(x)$  is a polynomial whose degree is even and whose leading coefficient is positive, we will look for a graph that goes up on the left and up on the right. Because the factors are  $x^2$ ,  $x + 3$ , and  $x - 2$ , we will also look for a graph with  $x$ -intercepts 0,  $-3$ , and 2. The graph in Figure 7.7 satisfies these conditions.

- $$g(x) = -\frac{1}{2}(x - 1)(x - 2)(x + 1) = -\frac{1}{2}x^3 + x^2 + \frac{1}{2}x - 1$$

Because  $g(x)$  is a polynomial whose degree is odd and whose leading coefficient is negative, we will look for a graph that goes up on the left and down on the right. The factors are  $x - 1$ ,  $x - 2$ , and  $x + 1$ , we will also look for a graph with 1, 2, and  $-1$  as  $x$ -intercepts. The graph in Figure 7.6 satisfies these conditions.

- $$P(x) = \frac{1}{10}(x - 2)^2(x + 2) = \frac{1}{10}x^3 - \frac{1}{5}x^2 - \frac{2}{5}x + \frac{4}{5}$$

Because  $P(x)$  is a polynomial whose degree is odd and whose leading term is positive, we will look for a graph that goes down on the left and up on the right. The  $x$ -intercepts are 2 and  $-2$ . The graph in Figure 7.5 satisfies these conditions.

## Sketching Graphs of Polynomials

To sketch the graph of most polynomial functions accurately, we need to use calculus (don't let that scare you—the calculus part is easier than the algebra part!) We can still get a pretty good graph using algebra alone. The general method is to plot  $x$ -intercepts (if there are any), a point to the left of the smallest  $x$ -intercept, a point between any two  $x$ -intercepts, and a point to the right of the largest  $x$ -intercept. Because  $y$ -intercepts are easy to find, it wouldn't hurt to plot these, too.

### EXAMPLES

- $f(x) = -(2x - 1)(x + 2)(x - 3)$

The  $x$ -intercepts are  $-2$ , 3, and  $\frac{1}{2}$  (from  $2x - 1 = 0$ ). In addition to the  $x$ -intercepts, we will plot the points for  $x = -2.5$  (to the left of  $x = -2$ ),  $x = -1$  (between  $x = -2$  and  $x = \frac{1}{2}$ ),  $x = 2$  (between  $x = \frac{1}{2}$  and  $x = 3$ ), and  $x = 3.5$  (to the right of  $x = 3$ ).



Table 7.1

$x$	$f(x)$
-2.5	16.5
-2	0
-1	-12
0	-6
$\frac{1}{2}$	0
2	12
3	0
3.5	-16.5

The reason we used  $x = -2.5$  instead of  $x = -3$  and  $x = 3.5$  instead of  $x = 4$  is that their  $y$ -values were too large for our graph.

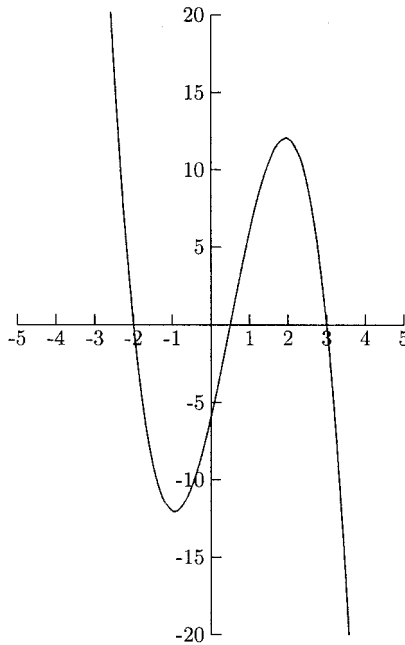

Fig. 7.8.

## PRACTICE

Match the graph of the given function with one of the graphs in Figures 7.1–7.4.

- $f(x) = -8x^3 + 4x^2 - 9x + 3$

## CHAPTER 7 Polynomial Functions

2.  $f(x) = 4x^5 + 10x^4 - 3x^3 + x^2$

3.  $P(x) = -x^2 + x - 6$

4.  $g(x) = 1 + x + x^2 + x^3$

Identify the  $x$ -intercepts and factors for the polynomial function whose graphs are given.

5.

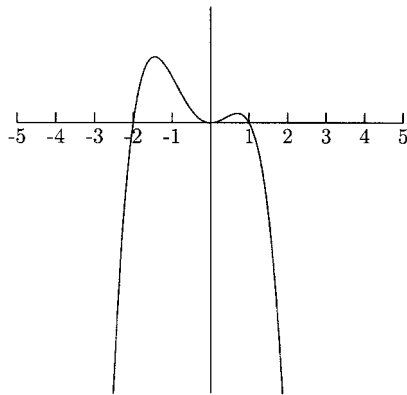

Fig. 7.9.

6.

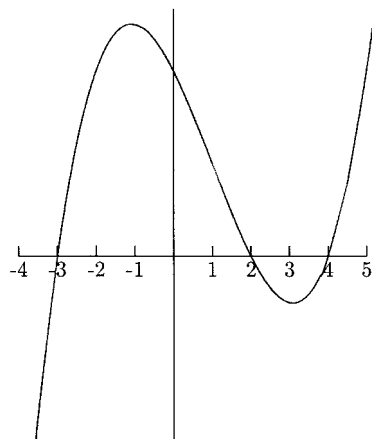

Fig. 7.10.

7.

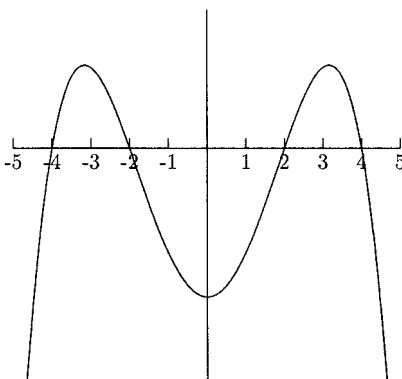

Fig. 7.11.

Match the polynomial function with one of the graphs in Figures 7.9 through 7.11.

8.  $f(x) = -\frac{1}{8}(x+4)(x+2)(x-2)(x-4) = -\frac{1}{8}x^4 + \frac{5}{2}x^2 - 8$
9.  $P(x) = -\frac{1}{2}x^2(x+2)(x-1) = -\frac{1}{2}x^4 - \frac{1}{2}x^3 + x^2$
10.  $R(x) = \frac{1}{2}(x+3)(x-2)(x-4) = \frac{1}{2}x^3 - \frac{3}{2}x^2 - 5x + 12$
11. Sketch the graph of  $f(x) = \frac{1}{2}x(x-2)(x+2)$ .
12. Sketch the graph of  $h(x) = -\frac{1}{10}(x+4)(x+1)(x-2)(x-3)$ .

## SOLUTIONS

1. Figure 7.4
2. Figure 7.3
3. Figure 7.2
4. Figure 7.3
5. The  $x$ -intercepts are  $-2$ ,  $0$ , and  $1$ , so  $x+2$ ,  $x$ , and  $x-1$  are factors of the polynomial.
6. The  $x$ -intercepts are  $-3$ ,  $2$ , and  $4$ , so  $x+3$ ,  $x-2$ , and  $x-4$  are factors of the polynomial.

## CHAPTER 7 Polynomial Functions

7. The  $x$ -intercepts are  $-4$ ,  $-2$ ,  $2$  and  $4$ , so  $x + 4$ ,  $x + 2$ ,  $x - 2$  and  $x - 4$  are factors of the polynomial.
8. Figure 7.11
9. Figure 7.9
10. Figure 7.10
- 11.

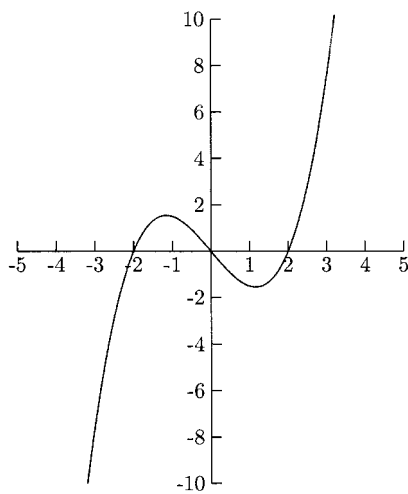

Fig. 7.12.

- 12.

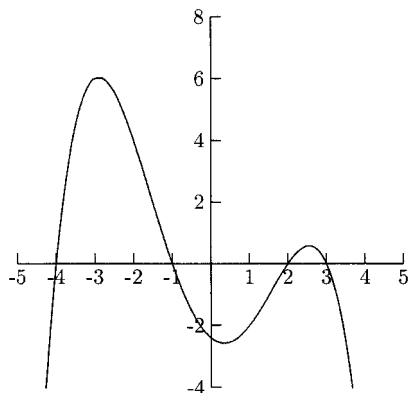

Fig. 7.13.

## Polynomial Division

Polynomials can be divided in much the same way as whole numbers. When we take the quotient of two whole numbers (where the divisor is not zero), we get a quotient and a remainder. The same happens when we take the quotient of two polynomials. Polynomial division is useful when factoring polynomials.

Polynomial division problems usually come in one of two forms.

$$\frac{\text{dividend polynomial}}{\text{divisor polynomial}} \text{ or dividend polynomial } \div \text{ divisor polynomial}$$

According to the division algorithm for polynomials, for any polynomials  $f(x)$  and  $g(x)$  (with  $g(x)$  not the zero function)

$$\frac{f(x)}{g(x)} = q(x) + \frac{r(x)}{g(x)},$$

where  $q(x)$  is the quotient (which might be 0) and  $r(x)$  is the remainder, which has degree *strictly* less than the degree of  $g(x)$ . Multiplying by  $g(x)$  to clear the fraction, we also get  $f(x) = g(x)q(x) + r(x)$ . First we will perform polynomial division using long division.

$$g(x) \overline{) f(x)} \\ \underline{\phantom{g(x)} q(x)} \\ r(x)$$

## EXAMPLES

Find the quotient and remainder using long division.

- $\frac{4x^2 + 3x - 5}{x + 2}$

$$x + 2 \overline{) 4x^2 + 3x - 5}$$

We will begin by dividing the leading term of the dividend by the leading term of the divisor. For the first step in this example, we will divide  $4x^2$  by  $x$ . You might see right away that  $4x^2 \div x$  is  $4x$ . If not, write  $4x^2 \div x$  as a fraction then reduce:  $\frac{4x^2}{x} = 4x$ . This will be the first term of the quotient.

$$x + 2 \overline{) 4x^2 + 3x - 5}$$

Multiply  $4x$  by the divisor:  $4x(x + 2) = 4x^2 + 8x$ . Subtract this from the first two terms of the dividend. Be careful to subtract all of  $4x^2 + 8x$ , not just  $4x^2$ .

$$\begin{array}{r}
 4x \\
 x + 2 \overline{) 4x^2 + 3x - 5} \\
 \underline{-(4x^2 + 8x)} \\
 -5x
 \end{array}$$

Bring down the next term.

$$\begin{array}{r}
 4x \\
 x + 2 \overline{) 4x^2 + 3x - 5} \\
 \underline{-(4x^2 + 8x)} \\
 -5x - 5
 \end{array}$$

Start the process again with  $-5x \div x = -5$ . The next term in the quotient is  $-5$ . Multiply  $x + 2$  by  $-5$ :  $-5(x + 2) = -5x - 10$ . Subtract this from  $-5x - 5$ .

$$\begin{array}{r}
 4x - 5 \\
 x + 2 \overline{) 4x^2 + 3x - 5} \\
 \underline{-(4x^2 + 8x)} \\
 -5x - 5 \\
 \underline{-(-5x - 10)} \\
 5
 \end{array}$$

We are done because  $5 \div x = \frac{5}{x}$  cannot be a term in a polynomial. The remainder is 5 and the quotient is  $4x - 5$ .

- $x^2 + 2x - 3 \overline{) 3x^4 + 5x^3 - 4x^2 + 7x - 1}$

Divide  $3x^4$  by  $x^2$  to get the first term of the quotient:  $\frac{3x^4}{x^2} = 3x^2$ . Multiply  $x^2 + 2x - 3$  by  $3x^2$ :  $3x^2(x^2 + 2x - 3) = 3x^4 + 6x^3 - 9x^2$ . Subtract this from the first three terms in the dividend.

$$\begin{array}{r}
 3x^2 \\
 x^2 + 2x - 3 \overline{) 3x^4 + 5x^3 - 4x^2 + 7x - 1} \\
 \underline{-(3x^4 + 6x^3 - 9x^2)} \\
 -x^3 + 5x^2
 \end{array}$$

Divide  $-x^3$  by  $x^2$  to get the second term in the quotient:  $\frac{-x^3}{x^2} = -x$ . Multiply  $x^2 + 2x - 3$  by  $-x$ :  $-x(x^2 + 2x - 3) = -x^3 - 2x^2 + 3x$ . Subtract this from  $-x^3 + 5x^2 + 7x$ .

$$\begin{array}{r}
 3x^2 - x \\
 x^2 + 2x - 3 \overline{) \begin{array}{l} 3x^4 + 5x^3 - 4x^2 + 7x - 1 \\ -(3x^4 + 6x^3 - 9x^2) \\ \hline -x^3 + 5x^2 + 7x \\ -(-x^3 - 2x^2 + 3x) \\ \hline 7x^2 + 4x \end{array} }
 \end{array}$$

Divide  $7x^2$  by  $x^2$  to get the third term in the quotient:  $\frac{7x^2}{x^2} = 7$ . Multiply  $x^2 + 2x - 3$  by 7:  $7(x^2 + 2x - 3) = 7x^2 + 14x - 21$ . Subtract this from  $7x^2 + 4x - 1$ .

$$\begin{array}{r}
 3x^2 - x + 7 \\
 x^2 + 2x - 3 \overline{) \begin{array}{l} 3x^4 + 5x^3 - 4x^2 + 7x - 1 \\ -(3x^4 + 6x^3 - 9x^2) \\ \hline -x^3 + 5x^2 + 7x \\ -(-x^3 - 2x^2 + 3x) \\ \hline 7x^2 + 4x - 1 \\ -(7x^2 + 14x - 21) \\ \hline -10x + 20 \end{array} }
 \end{array}$$

Because  $\frac{-10x}{x^2}$  cannot be a term in a polynomial, we are done. The quotient is  $3x^2 - x + 7$ , and the remainder is  $-10x + 20$ .

It is important that every power of  $x$ , from the highest power to the constant term, be represented in the polynomial. Although it is possible to perform long division without all powers represented, it is very easy to make an error. Also, it is not possible to perform synthetic division (later in this chapter) without a coefficient for *every* term. If a power of  $x$  is not written, we need to rewrite the polynomial (either the dividend, divisor, or both) using a coefficient of 0 on the missing powers. For example, we would write  $x^3 - 1$  as  $x^3 + 0x^2 + 0x - 1$ .

### EXAMPLE

- $(x^3 - 8) \div (x + 1)$   
Rewrite as  $(x^3 + 0x^2 + 0x - 8) \div (x + 1)$

$$\begin{array}{r}
 x^2 - x + 1 \\
 x + 1 \overline{) \begin{array}{l} x^3 + 0x^2 + 0x - 8 \\ -(x^3 + x^2) \\ \hline -x^2 + 0x \\ -(-x^2 - x) \\ \hline x - 8 \\ -(x + 1) \\ \hline -9 \end{array} }
 \end{array}$$

The quotient is  $x^2 - x + 1$ , and the remainder is  $-9$ .

Polynomial division is a little trickier when the leading coefficient of the divisor is not 1. The terms of the quotient are harder to find and are likely to be fractions.

## EXAMPLES

Find the quotient and remainder using long division.

- $\frac{x^2 - x + 2}{2x - 1}$

Find the first term in the quotient by dividing the first term of the dividend by the first term in the divisor:

$$\frac{x^2}{2x} = \frac{x}{2} = \frac{1}{2}x.$$

$$2x - 1 \overline{) \begin{array}{r} \frac{1}{2}x \\ x^2 - x + 2 \\ -(x^2 - \frac{1}{2}x) \\ \hline -\frac{1}{2}x + 2 \end{array}}$$

The second term in the quotient is

$$\frac{-\frac{1}{2}x}{2x} = \frac{-\frac{1}{2}}{2} = -\frac{1}{2} \div 2 = -\frac{1}{2} \cdot \frac{1}{2} = -\frac{1}{4}.$$

Multiply  $2x - 1$  by  $-\frac{1}{4}$ :  $-\frac{1}{4}(2x - 1) = -\frac{1}{2}x + \frac{1}{4}$ .

$$2x - 1 \overline{) \begin{array}{r} \frac{1}{2}x - \frac{1}{4} \\ x^2 - x + 2 \\ -(x^2 - \frac{1}{2}x) \\ \hline -\frac{1}{2}x + 2 \\ -(-\frac{1}{2}x + \frac{1}{4}) \\ \hline \frac{7}{4} \end{array}}$$

The quotient is  $\frac{1}{2}x - \frac{1}{4}$ , and the remainder is  $\frac{7}{4}$ .

- $(4x^2 + 5x - 6) \div \left(\frac{2}{3}x - 1\right)$

Find the first term in the quotient by dividing the leading term in the quotient by the first term in the divisor.

$$\frac{4x^2}{\frac{2}{3}x} = \frac{4x}{\frac{2}{3}} = 4x \div \frac{2}{3} = 4x \cdot \frac{3}{2} = 6x$$

$$6x \left(\frac{2}{3}x - 1\right) = 4x^2 - 6x$$



$$\frac{2}{3}x - 1 \overline{) \begin{array}{r} 4x^2 + 5x - 6 \\ -(4x^2 - 6x) \\ \hline 11x - 6 \end{array}}$$

$$\frac{11x}{\frac{2}{3}x} = \frac{11}{\frac{2}{3}} = 11 \div \frac{2}{3} = 11 \cdot \frac{3}{2} = \frac{33}{2}$$

$$\frac{33}{2} \left( \frac{2}{3}x - 1 \right) = 11x - \frac{33}{2}$$

$$\frac{2}{3}x - 1 \overline{) \begin{array}{r} 6x + \frac{33}{2} \\ 4x^2 + 5x - 6 \\ -(4x^2 - 6x) \\ \hline 11x - 6 \\ -(11x - \frac{33}{2}) \\ \hline \frac{21}{2} \end{array}}$$

The quotient is  $6x + \frac{33}{2}$ , and the remainder is  $\frac{21}{2}$ .

Synthetic division of polynomials is much easier than long division. It only works when the divisor is of a certain form, though. Here, we will use synthetic division when the divisor is of the form “ $x - \text{number}$ ” or “ $x + \text{number}$ .”

For a problem of the form

$$\frac{a_n x^n + a_{n-1} x^{n-1} + \cdots + a_1 x + a_0}{x - c} \text{ or}$$

$$(a_n x^n + a_{n-1} x^{n-1} + \cdots + a_1 x + a_0) \div (x - c),$$

write

$$c \overline{) \begin{array}{r} a_n \\ a_{n-1} \\ \dots \\ a_1 \\ a_0 \end{array}}$$

Every power of  $x$  must be represented.

In synthetic division, the tedious work in long division is reduced to a few steps.

## EXAMPLES

Find the quotient and remainder using synthetic division.

- $$\frac{4x^3 - 5x^2 + x - 8}{x - 2}$$

$$2 \overline{) 4 \quad -5 \quad 1 \quad -8}$$

Bring down the first coefficient.

$$\begin{array}{r} 2 \overline{) 4 \quad -5 \quad 1 \quad -8} \\ \underline{4} \phantom{000} \\ \phantom{4} \phantom{00} \phantom{00} \phantom{00} \end{array}$$

Multiply this coefficient by 2 (the  $c$ ) and put the product under  $-5$ , the next coefficient.

$$\begin{array}{r} 2 \overline{) 4 \quad -5 \quad 1 \quad -8} \\ \underline{4 \phantom{00} \phantom{00} \phantom{00}} \\ \phantom{4} \phantom{00} \phantom{00} \phantom{00} \phantom{00} \end{array}$$

Add  $-5$  and  $8$ . Put the sum under  $8$ .

$$\begin{array}{r} 2 \overline{) 4 \quad -5 \quad 1 \quad -8} \\ \underline{4 \phantom{00} \phantom{00} \phantom{00}} \\ \phantom{4} \phantom{00} \phantom{00} \phantom{00} \phantom{00} \phantom{00} \end{array}$$

Multiply  $3$  by  $2$  and put the product under  $1$ , the next coefficient.

$$\begin{array}{r} 2 \overline{) 4 \quad -5 \quad 1 \quad -8} \\ \underline{4 \phantom{00} \phantom{00} \phantom{00}} \\ \phantom{4} \phantom{00} \phantom{00} \phantom{00} \phantom{00} \phantom{00} \end{array}$$

Add  $1$  and  $6$ . Put the sum under  $6$ .

$$\begin{array}{r} 2 \overline{) 4 \quad -5 \quad 1 \quad -8} \\ \underline{4 \phantom{00} \phantom{00} \phantom{00}} \\ \phantom{4} \phantom{00} \phantom{00} \phantom{00} \phantom{00} \phantom{00} \end{array}$$

Multiply  $7$  by  $2$ . Put the product under  $-8$ , the last coefficient.

$$\begin{array}{r} 2 \overline{) 4 \quad -5 \quad 1 \quad -8} \\ \underline{4 \phantom{00} \phantom{00} \phantom{00}} \\ \phantom{4} \phantom{00} \phantom{00} \phantom{00} \phantom{00} \phantom{00} \end{array}$$

Add  $-8$  and  $14$ . Put the sum under  $14$ . This is the last step.

$$\begin{array}{r} 2 \overline{) 4 \quad -5 \quad 1 \quad -8} \\ \underline{4 \phantom{00} \phantom{00} \phantom{00}} \\ \phantom{4} \phantom{00} \phantom{00} \phantom{00} \phantom{00} \phantom{00} \end{array}$$

The numbers on the last row are the coefficients of the quotient and the remainder. The remainder is a constant (which is a term of degree 0), and the degree of the quotient is exactly one less degree than the degree of

the dividend. In this example, the degree of the dividend is 3, so the degree of the quotient is 2. The last number on the bottom row is the remainder. The numbers before it are the coefficients of the quotient, in order from the highest degree to the lowest. The remainder in this example is 6. The coefficients of the quotient are 4, 3, and 7. The quotient is  $4x^2 + 3x + 7$ .

- $(3x^4 - x^2 + 2x + 9) \div (x + 5)$

Because  $x + 5 = x - (-5)$ ,  $c = -5$ .

$$-5 \overline{) 3 \ 0 \ -1 \ 2 \ 9}$$

Bring down 3, the first coefficient. Multiply it by  $-5$ . Put  $3(-5) = -15$  under 0.

$$\begin{array}{r} -5 \overline{) 3 \ 0 \ -1 \ 2 \ 9} \\ \underline{-15} \phantom{00} \\ 3 \phantom{000} \end{array}$$

Add  $0 + (-15) = -15$ . Multiply  $-15$  by  $-5$  and put  $(-15)(-5) = 75$  under  $-1$ .

$$\begin{array}{r} -5 \overline{) 3 \ 0 \ -1 \ 2 \ 9} \\ \underline{-15 \ 75} \phantom{00} \\ 3 \ -15 \phantom{00} \end{array}$$

Add  $-1$  and  $75$ . Multiply  $-1 + 75 = 74$  by  $-5$  and put  $(74)(-5) = -370$  under  $2$ .

$$\begin{array}{r} -5 \overline{) 3 \ 0 \ -1 \ 2 \ 9} \\ \underline{-15 \ 75 \ -370} \phantom{00} \\ 3 \ -15 \ 74 \phantom{00} \end{array}$$

Add  $2$  to  $-370$ . Multiply  $2 + (-370) = -368$  by  $-5$  and put  $(-368)(-5) = 1840$  under  $9$ .

$$\begin{array}{r} -5 \overline{) 3 \ 0 \ -1 \ 2 \ 9} \\ \underline{-15 \ 75 \ -370 \ 1840} \\ 3 \ -15 \ 74 \ -368 \end{array}$$

Add  $9$  to  $1840$ . Put  $9 + 1840 = 1849$  under  $1840$ .

$$\begin{array}{r} -5 \overline{) 3 \ 0 \ -1 \ 2 \ 9} \\ \underline{-15 \ 75 \ -370 \ 1840} \\ 3 \ -15 \ 74 \ -368 \ 1849 \end{array}$$

The dividend has degree 4, so the quotient has degree 3. The quotient is  $3x^3 - 15x^2 + 74x - 368$  and the remainder is 1849.

When dividing a polynomial  $f(x)$  by  $x - c$ , the remainder tells us two things. If we get a remainder of 0, then both the divisor,  $(x - c)$ , and

quotient are factors of  $f(x)$ . Another fact we get from the remainder is that  $f(c) = \text{remainder}$ .

$$f(x) = (x - c)q(x) + \text{remainder}$$

$$f(c) = (c - c)q(c) + \text{remainder} \quad \text{Evaluate } f(x) \text{ at } x = c.$$

$$f(c) = 0q(c) + \text{remainder}$$

$$f(c) = \text{remainder}$$

The fact that  $f(c)$  is the remainder is called the *Remainder Theorem*. It is useful when trying to evaluate complicated polynomials. We can also use this fact to check our work with synthetic division and long division (providing the divisor is  $x - c$ ).

- $(x^3 - 6x^2 + 4x - 5) \div (x - 3)$

By the Remainder Theorem, we should get the remainder to be  $3^3 - 6(3^2) + 4(3) - 5 = -20$ .

$$\begin{array}{r|rrrr} 3 & 1 & -6 & 4 & -5 \\ & & 3 & -9 & -15 \\ \hline & 1 & -3 & -5 & -20 \end{array}$$

## EXAMPLE

Use synthetic division and the Remainder Theorem to evaluate  $f(c)$ .

- $f(x) = 14x^3 - 16x^2 + 10x + 8; c = 1$ .

We will first perform synthetic division with  $x - c = x - 1$ .

$$\begin{array}{r|rrrr} 1 & 14 & -16 & 10 & 8 \\ & & 14 & -2 & 8 \\ \hline & 14 & -2 & 8 & 16 \end{array}$$

The remainder is 16, so  $f(1) = 16$ .

Now we will use synthetic division and the Remainder Theorem to factor polynomials. Suppose  $x = c$  is a zero for a polynomial  $f(x)$ . Let us see what happens when we divide  $f(x)$  by  $x - c$ .

$$f(x) = (x - c)q(x) + r(x)$$

Because  $x = c$  is a zero, the remainder is 0, so  $f(x) = (x - c)q(x) + 0$ , which means  $f(x) = (x - c)q(x)$ . The next step in completely factoring  $f(x)$  is factoring  $q(x)$ , if necessary.

## EXAMPLES

Completely factor the polynomials.

- $f(x) = x^3 - 4x^2 - 7x + 10$ ,  $c = 1$  is a zero.  
We will use the fact that  $c = 1$  is a zero to get started. We will use synthetic division to divide  $f(x)$  by  $x - 1$ .

$$\begin{array}{r|rrrr} 1 & 1 & -4 & -7 & 10 \\ & & 1 & -3 & -10 \\ \hline & 1 & -3 & -10 & 0 \end{array}$$

The quotient is  $x^2 - 3x - 10$ . We now have  $f(x)$  partially factored.

$$\begin{aligned} f(x) &= x^3 - 4x^2 - 7x + 10 \\ &= (x - 1)(x^2 - 3x - 10) \end{aligned}$$

Because the quotient is quadratic, we can factor it directly or by using the quadratic formula.

$$x^2 - 3x - 10 = (x - 5)(x + 2)$$

Now we have the complete factorization of  $f(x)$ :

$$\begin{aligned} f(x) &= x^3 - 4x^2 - 7x + 10 \\ &= (x - 1)(x - 5)(x + 2). \end{aligned}$$

- $R(x) = x^3 - 2x + 1$ ,  $c = 1$  is a zero.

$$\begin{array}{r|rrrr} 1 & 1 & 0 & -2 & 1 \\ & & 1 & 1 & -1 \\ \hline & 1 & 1 & -1 & 0 \end{array}$$

$$R(x) = x^3 - 2x + 1 = (x - 1)(x^2 + x - 1)$$

We will use the quadratic formula to find the two zeros of  $x^2 + x - 1$ .

$$\begin{aligned} x &= \frac{-1 \pm \sqrt{1^2 - 4(1)(-1)}}{2(1)} \\ &= \frac{-1 \pm \sqrt{5}}{2} = \frac{-1 + \sqrt{5}}{2}, \frac{-1 - \sqrt{5}}{2} \end{aligned}$$

The factors for these zeros are  $x - \frac{-1+\sqrt{5}}{2}$  and  $x - \frac{-1-\sqrt{5}}{2}$ .

$$R(x) = (x - 1) \left( x - \frac{-1 + \sqrt{5}}{2} \right) \left( x - \frac{-1 - \sqrt{5}}{2} \right)$$

## PRACTICE

For Problems 1–4 use long division to find the quotient and remainder. For Problems 5 and 6, use synthetic division

- $(6x^3 - 2x^2 + 5x - 1) \div (x^2 + 3x + 2)$
- $(x^3 - x^2 + 2x + 5) \div (3x - 4)$
- $$\frac{3x^3 - x^2 + 4x + 2}{-\frac{1}{2}x^2 + 1}$$
- $$\frac{x^3 - 1}{x - 1}$$
- $$\frac{x^3 + 2x^2 + x - 8}{x + 3}$$
- $(x^3 + 8) \div (x + 2)$
- Use synthetic division and the Remainder Theorem to evaluate  $f(c)$ .  
 $f(x) = 6x^4 - 8x^3 + x^2 + 2x - 5; c = -2$
- Completely factor the polynomial.  $f(x) = x^3 + 2x^2 - x - 2; c = 1$  is a zero.
- Completely factor the polynomial.  $P(x) = x^3 - 5x^2 + 5x + 3; c = 3$  is a zero.

## SOLUTIONS

$$\begin{array}{r}
 1. \qquad \qquad \qquad 6x - 20 \\
 x^2 + 3x + 2 \overline{) 6x^3 - 2x^2 + 5x - 1} \\
 \underline{-(6x^3 + 18x^2 + 12x)} \phantom{- 1} \\
 \phantom{x^2 + 3x + 2 \overline{) }} -20x^2 - 7x - 1 \\
 \underline{-(-20x^2 - 60x - 40)} \\
 \phantom{x^2 + 3x + 2 \overline{) }} \phantom{-20x^2 - 7x - 1} 53x + 39
 \end{array}$$

The quotient is  $6x - 20$ , and the remainder is  $53x + 39$ .

2.

$$3x - 4 \overline{\begin{array}{r} \frac{1}{3}x^2 + \frac{1}{9}x \\ x^3 - x^2 + 2x + 5 \\ -(x^3 - \frac{4}{3}x^2) \\ \hline \frac{1}{3}x^2 + 2x \\ -(\frac{1}{3}x^2 - \frac{4}{9}x) \\ \hline \frac{22}{9}x + 5 \end{array}}$$

$$\frac{\frac{22}{9}x}{3x} = \frac{\frac{22}{9}}{3} = \frac{22}{9} \cdot \frac{1}{3} = \frac{22}{27}$$

$$\frac{22}{27}(3x - 4) = \frac{22}{9}x - \frac{88}{27}$$

$$3x - 4 \overline{\begin{array}{r} \frac{1}{3}x^2 + \frac{1}{9}x + \frac{22}{27} \\ x^3 - x^2 + 2x + 5 \\ -(x^3 - \frac{4}{3}x^2) \\ \hline \frac{1}{3}x^2 + 2x \\ -(\frac{1}{3}x^2 - \frac{4}{9}x) \\ \hline \frac{22}{9}x + 5 \\ -(\frac{22}{9}x - \frac{88}{27}) \\ \hline \frac{223}{27} \end{array}}$$

The quotient is  $\frac{1}{3}x^2 + \frac{1}{9}x + \frac{22}{27}$ , and the remainder is  $\frac{223}{27}$ .

$$3. \quad \frac{3x^3}{-\frac{1}{2}x^2} = \frac{3x}{-\frac{1}{2}} = 3x \div -\frac{1}{2} = 3x \cdot (-2) = -6x$$

$$-6x(-\frac{1}{2}x^2 + 0x + 1) = 3x^3 + 0x^2 - 6x$$

$$-\frac{1}{2}x^2 + 0x + 1 \overline{\begin{array}{r} -6x \\ 3x^3 - x^2 + 4x + 2 \\ -(3x^3 - 0x^2 - 6x) \\ \hline -x^2 + 10x + 2 \end{array}}$$

$$\frac{-x^2}{-\frac{1}{2}x^2} = \frac{1}{\frac{1}{2}} = 1 \div \frac{1}{2} = 1 \cdot 2 = 2$$

$$2\left(-\frac{1}{2}x^2 + 0x + 1\right) = -x^2 + 0x + 2$$

$$\begin{array}{r}
 -\frac{1}{2}x^2 + 0x + 1 \overline{) \begin{array}{r} 3x^3 - x^2 + 4x + 2 \\ -(3x^3 - 0x^2 - 6x) \\ \hline -x^2 + 10x + 2 \\ -(-x^2 + 0x + 2) \\ \hline 10x + 0 \end{array}}
 \end{array}$$

The quotient is  $-6x + 2$ , and the remainder is  $10x$ .

4.

$$\begin{array}{r}
 x^2 + x + 1 \overline{) \begin{array}{r} x^3 + 0x^2 + 0x - 1 \\ -(x^3 - x^2) \\ \hline x^2 + 0x - 1 \\ -(x^2 - x) \\ \hline x - 1 \\ -(x - 1) \\ \hline 0 \end{array}}
 \end{array}$$

The quotient is  $x^2 + x + 1$ , and the remainder is 0.

5.

$$\begin{array}{r}
 -3 \overline{) \begin{array}{r} 1 \quad 2 \quad 1 \quad -8 \\ -3 \quad 3 \quad -12 \\ \hline 1 \quad -1 \quad 4 \quad -20 \end{array}}
 \end{array}$$

The quotient is  $x^2 - x + 4$ , and the remainder is  $-20$ .

6.

$$\begin{array}{r}
 -2 \overline{) \begin{array}{r} 1 \quad 0 \quad 0 \quad 8 \\ -2 \quad 4 \quad -8 \\ \hline 1 \quad -2 \quad 4 \quad 0 \end{array}}
 \end{array}$$

The quotient is  $x^2 - 2x + 4$ , and the remainder is 0.

7.

$$\begin{array}{r}
 -2 \overline{) \begin{array}{r} 6 \quad -8 \quad 1 \quad 2 \quad -5 \\ -12 \quad 40 \quad -82 \quad 160 \\ \hline 6 \quad -20 \quad 41 \quad -80 \quad 155 \end{array}}
 \end{array}$$

The remainder is 155, so  $f(-2) = 155$ .

8.

$$\begin{array}{r}
 1 \overline{) \begin{array}{r} 1 \quad 2 \quad -1 \quad -2 \\ 1 \quad 3 \quad 2 \\ \hline 1 \quad 3 \quad 2 \quad 0 \end{array}}
 \end{array}$$

$$\begin{aligned}
 f(x) &= (x - 1)(x^2 + 3x + 2) \\
 &= (x - 1)(x + 1)(x + 2)
 \end{aligned}$$



$$9. \quad \begin{array}{r|rrrr} 3 & 1 & -5 & 5 & 3 \\ & & 3 & -6 & -3 \\ \hline & 1 & -2 & -1 & 0 \end{array}$$

$$P(x) = (x - 3)(x^2 - 2x - 1)$$

In order to factor  $x^2 - 2x - 1$ , we must first find its zeros.

$$\begin{aligned} x &= \frac{-(-2) \pm \sqrt{(-2)^2 - 4(1)(-1)}}{2(1)} \\ &= \frac{2 \pm \sqrt{8}}{2} = \frac{2 \pm 2\sqrt{2}}{2} \\ &= \frac{2(1 \pm \sqrt{2})}{2} = 1 \pm \sqrt{2} \\ &= 1 + \sqrt{2}, 1 - \sqrt{2} \end{aligned}$$

Because  $x = 1 + \sqrt{2}$  is a zero,  $x - (1 + \sqrt{2}) = x - 1 - \sqrt{2}$  is a factor.  
Because  $x = 1 - \sqrt{2}$  is a zero,  $x - (1 - \sqrt{2}) = x - 1 + \sqrt{2}$  is a factor.

$$P(x) = (x - 3)(x - 1 - \sqrt{2})(x - 1 + \sqrt{2})$$

In the above examples and practice problems, a zero was given to help us get started with factoring. Usually, we have to find a starting point ourselves. The *Rational Zero Theorem* gives us a place to start. The Rational Zero Theorem says that if a polynomial function  $f(x)$ , with integer coefficients, has a rational number  $p/q$  as a zero, then  $p$  is a divisor of the constant term and  $q$  is a divisor of the leading coefficient. Not all polynomials have rational zeros, but most of those in precalculus courses do.

The Rational Zero Theorem is used to create a list of candidates for zeros. These candidates are rational numbers whose numerators divide the polynomial's constant term and whose denominators divide its leading coefficient. Once we have this list, we will try each number in the list to see which, if any, are zeros. Once we have found a zero, we can begin to factor the polynomial.

## EXAMPLES

List the possible rational zeros.

- $f(x) = 4x^3 + 6x^2 - 2x + 9$

The numerators in our list will be the divisors of 9: 1, 3, and 9 as well as their negatives,  $-1$ ,  $-3$ , and  $-9$ . The denominators will be the divisors of 4: 1, 2, and 4. The list of possible rational zeros is—

$$\frac{1}{1}, \frac{3}{1}, \frac{9}{1}, -\frac{1}{1}, -\frac{3}{1}, -\frac{9}{1}, \frac{1}{2}, \frac{3}{2}, \frac{9}{2},$$

$$-\frac{1}{2}, -\frac{3}{2}, -\frac{9}{2}, \frac{1}{4}, \frac{3}{4}, \frac{9}{4}, -\frac{1}{4}, -\frac{3}{4}, \text{ and } -\frac{9}{4}.$$

This list could be written with a little less effort as  $\pm 1$ ,  $\pm 3$ ,  $\pm 9$ ,  $\pm \frac{1}{2}$ ,  $\pm \frac{3}{2}$ ,  $\pm \frac{9}{2}$ ,  $\pm \frac{1}{4}$ ,  $\pm \frac{3}{4}$ ,  $\pm \frac{9}{4}$ .

We only need to list the numerators with negative numbers and not the denominators. The reason is that no new numbers are added to the list, only duplicates of numbers already there. For example,  $-\frac{1}{2}$  and  $\frac{1}{-2}$  are the same number.

- $g(x) = 6x^4 - 5x^3 + 2x - 8$

The possible numerators are the divisors of 8:  $\pm 1$ ,  $\pm 2$ ,  $\pm 4$ , and  $\pm 8$ . The possible denominators are the divisors of 6: 1, 2, 3, and 6. The list of possible rational zeros is—

$$\pm 1, \pm 2, \pm 4, \pm 8, \pm \frac{1}{2}, \pm \frac{2}{2}, \pm \frac{4}{2}, \pm \frac{8}{2}, \pm \frac{1}{3}, \pm \frac{2}{3}, \pm \frac{4}{3}, \pm \frac{8}{3}, \pm \frac{1}{6}, \pm \frac{2}{6},$$

$$\pm \frac{4}{6}, \pm \frac{8}{6}.$$

There are several duplicates on this list. There will be duplicates when the constant term and leading coefficient have common factors. The duplicates don't really hurt anything, but they could waste time when checking the list for zeros.

Now that we have a starting place, we can factor many polynomials. Here is the strategy. First we will see if the polynomial can be factored directly. If not, we need to list the possible rational zeros. Then we will try the numbers in this list, one at a time, until we find a zero. Once we have found a zero, we will use polynomial division (long division or synthetic division) to find the quotient. Next, we will factor the quotient. If the quotient is a quadratic factor, we will either factor it directly or use the quadratic formula to find its zeros. If the quotient is a polynomial of degree 3 or higher, we will need to start over to factor the quotient. Eventually, the quotient will be a quadratic factor.

## EXAMPLES

Completely factor each polynomial.

- $f(x) = 3x^4 - 2x^3 - 7x^2 - 2x$

First we will factor  $x$  from each term:  $f(x) = x(3x^3 - 2x^2 - 7x - 2)$ . The possible rational zeros for  $3x^3 - 2x^2 - 7x - 2$  are  $\pm 1$ ,  $\pm 2$ ,  $\pm \frac{1}{3}$ ,  $\pm \frac{2}{3}$ .

$$3(1)^3 - 2(1)^2 - 7(1) - 2 \neq 0$$

$$3(-1)^3 - 2(-1)^2 - 7(-1) - 2 = 0$$

We will use synthetic division to find the quotient for  $(3x^3 - 2x^2 - 7x - 2) \div (x + 1)$ .

$$\begin{array}{r|rrrr} -1 & 3 & -2 & -7 & -2 \\ & & -3 & 5 & 2 \\ \hline & 3 & -5 & -2 & 0 \end{array}$$

The quotient is  $3x^2 - 5x - 2$  which factors into  $(3x + 1)(x - 2)$ .

$$\begin{aligned} f(x) &= 3x^4 - 2x^3 - 7x^2 - 2x \\ &= x(3x^3 - 2x^2 - 7x - 2) \\ &= x(x + 1)(3x^2 - 5x - 2) \\ &= x(x + 1)(3x + 1)(x - 2) \end{aligned}$$

- $h(x) = 3x^3 + 4x^2 - 18x + 5$

The possible rational zeros are  $\pm 1$ ,  $\pm 5$ ,  $\pm \frac{1}{3}$ , and  $\pm \frac{5}{3}$ .

$$h(1) = 3(1^3) + 4(1^2) - 18(1) + 5 \neq 0$$

$$h(-1) = 3(-1)^3 + 4(-1)^2 - 18(-1) + 5 \neq 0$$

$$h(5) = 3(5^3) + 4(5^2) - 18(5) + 5 \neq 0$$

Continuing in this way, we see that  $h(-5) \neq 0$ ,  $h(\frac{1}{3}) \neq 0$ ,  $h(-\frac{1}{3}) \neq 0$  and  $h(\frac{5}{3}) = 0$ .

$$\begin{array}{r|rrrr} \frac{5}{3} & 3 & 4 & -18 & 5 \\ & & 5 & 15 & -5 \\ \hline & 3 & 9 & -3 & 0 \end{array}$$

$$\begin{aligned} h(x) &= \left(x - \frac{5}{3}\right)(3x^2 + 9x - 3) \\ &= \left(x - \frac{5}{3}\right)(3)(x^2 + 3x - 1) = \left[3\left(x - \frac{5}{3}\right)\right](x^2 + 3x - 1) \\ &= (3x - 5)(x^2 + 3x - 1) \end{aligned}$$

We will find the zeros of  $x^2 + 3x - 1$  using the quadratic formula.

$$\begin{aligned} x &= \frac{-3 \pm \sqrt{3^2 - 4(1)(-1)}}{2(1)} \\ &= \frac{-3 \pm \sqrt{13}}{2} = \frac{-3 + \sqrt{13}}{2}, \quad \frac{-3 - \sqrt{13}}{2} \end{aligned}$$

$$h(x) = (3x - 5) \left(x - \frac{-3 + \sqrt{13}}{2}\right) \left(x - \frac{-3 - \sqrt{13}}{2}\right)$$

For a polynomial such as  $f(x) = 5x^3 + 20x^2 - 9x - 36$ , the list of possible rational zeros is quite long—36! There are ways of getting around having to test every one of them. The fastest way is to use a graphing calculator to sketch the graph of  $y = 5x^3 + 20x^2 - 9x - 36$ . There appears to be an  $x$ -intercept at  $x = -4$  (remember that  $x$ -intercepts are zeros.)

$$\begin{array}{r} -4 \overline{) 5 \quad 20 \quad -9 \quad -36} \\ \underline{5 \quad 20 \quad -20 \quad 0} \phantom{0} \\ 5 \quad 0 \quad -9 \quad 0 \phantom{0} \\ \underline{5 \quad 0 \quad -9 \quad 0} \\ 0 \phantom{0} \end{array}$$

$f(x) = (x + 4)(5x^2 - 9)$  We will solve  $5x^2 - 9 = 0$  to find the other zeros.

$$5x^2 - 9 = 0$$

$$5x^2 = 9$$

$$x^2 = \frac{9}{5}$$

$$x = \pm \sqrt{\frac{9}{5}} = \pm \frac{3}{\sqrt{5}}$$

$$\begin{aligned}
 &= \pm \frac{3}{\sqrt{5}} \cdot \frac{\sqrt{5}}{\sqrt{5}} \\
 &= \pm \frac{3\sqrt{5}}{5} = \frac{3\sqrt{5}}{5}, \quad -\frac{3\sqrt{5}}{5}
 \end{aligned}$$

$$f(x) = (x + 4) \left( x - \frac{3\sqrt{5}}{5} \right) \left( x + \frac{3\sqrt{5}}{5} \right)$$

There are also a couple of algebra facts that can help eliminate some of the possible rational zeros. The first we will learn is *Descartes' Rule of Signs*. The second is the *Upper and Lower Bounds Theorem*. Descartes' Rule of Signs counts the number of positive zeros and negative zeros. For instance, according to the rule  $f(x) = x^3 + x^2 + 4x + 6$  has no positive zeros at all. This shrinks the list of possible rational zeros from  $\pm 1$ ,  $\pm 2$ ,  $\pm 3$ , and  $\pm 6$  to  $-1$ ,  $-2$ ,  $-3$ , and  $-6$ . Another advantage of the sign test is that if we know that there are two positive zeros and we have found one of them, then we *know* that there is exactly one more.

The Upper and Lower Bounds Theorem gives us an idea of how large (in both the positive and negative directions) the zeros can be. For example, we can use the Upper and Lower Bounds Theorem to show that all of the zeros for  $f(x) = 5x^3 + 20x^2 - 9x - 36$  are between  $-5$  and  $5$ . This shrinks the list of possible rational zeros from  $\pm 1$ ,  $\pm 2$ ,  $\pm 3$ ,  $\pm 4$ ,  $\pm 6$ ,  $\pm 9$ ,  $\pm 12$ ,  $\pm 18$ ,  $\pm 36$ ,  $\pm \frac{1}{5}$ ,  $\pm \frac{2}{5}$ ,  $\pm \frac{3}{5}$ ,  $\pm \frac{4}{5}$ ,  $\pm \frac{6}{5}$ ,  $\pm \frac{9}{5}$ ,  $\pm \frac{12}{5}$ ,  $\pm \frac{18}{5}$ , and  $\pm \frac{36}{5}$  to  $\pm 1$ ,  $\pm 2$ ,  $\pm 3$ ,  $\pm 4$ ,  $\pm \frac{1}{5}$ ,  $\pm \frac{2}{5}$ ,  $\pm \frac{3}{5}$ ,  $\pm \frac{4}{5}$ ,  $\pm \frac{6}{5}$ ,  $\pm \frac{9}{5}$ ,  $\pm \frac{12}{5}$ , and  $\pm \frac{18}{5}$ .

Descartes' Rule of Signs counts the number of positive zeros and the number of negative zeros by counting sign changes. The maximum number of positive zeros for a polynomial function is the number of sign changes in  $f(x) = a_n x^n + a_{n-1} x^{n-1} + \cdots + a_1 x + a_0$ . The possible number of positive zeros is the number of sign changes minus an even whole number. For example, if there are 5 sign changes, there are 5 or 3 or 1 positive zeros. If there are 6 sign changes, there are 6 or 4 or 2 or 0 positive zeros. The polynomial function  $f(x) = 3x^4 - 2x^3 + 7x^2 + 5x - 8$  has 3 sign changes: from 3 to  $-2$ , from  $-2$  to 7, and from 5 to  $-8$ . There are either 3 or 1 positive zeros. The maximum number of negative zeros is the number of sign changes in the polynomial  $f(-x)$ . The possible number of negative zeros is the number of sign changes in  $f(-x)$  minus an even whole number.

## EXAMPLES

Use Descartes' Rule of Signs to count the possible number of positive zeros and negative zeros for the polynomial functions.

- $f(x) = 5x^3 - 6x^2 - 10x + 4$

There are 2 sign changes: from 5 to  $-6$  and from  $-10$  to 4. This means that there are either 2 or 0 positive zeros. Before we count the possible number of negative zeros, remember from earlier in the book that for a number  $a$ ,  $a(-x)^{\text{even power}} = ax^{\text{even power}}$  and  $a(-x)^{\text{odd power}} = -ax^{\text{odd power}}$ .

$$\begin{aligned} f(-x) &= 5(-x)^3 - 6(-x)^2 - 10(-x) + 4 \\ &= -5x^3 - 6x^2 + 10x + 4 \end{aligned}$$

There is 1 sign change, from  $-6$  to 10, so there is exactly 1 negative zero.

- $P(x) = x^5 + x^3 + x + 4$

There are no sign changes, so there are no positive zeros.

$$\begin{aligned} P(-x) &= (-x)^5 + (-x)^3 + (-x) + 4 \\ &= -x^5 - x^3 - x + 4 \end{aligned}$$

There is 1 sign change, so there is exactly 1 negative zero.

The Upper and Lower Bounds Theorem helps us to find a range of  $x$ -values that will contain all real zeros. It does *not* tell us what these bounds are. We make a guess as to what these bounds are then check them. For a negative number  $x = a$ , the statement “ $a$  is a lower bound for the real zeros” means that there is no number to the left of  $x = a$  on the  $x$ -axis that is a zero. For a positive number  $x = b$ , the statement “ $b$  is an upper bound for the real zeros” means that there is no number to the right of  $x = b$  on the  $x$ -axis that is a zero. In other words, all of the  $x$ -intercepts are between  $a$  and  $b$ .

To determine whether a negative number  $x = a$  is a lower bound for a polynomial, we need to use synthetic division. If the numbers in the bottom row alternate between nonpositive and nonnegative numbers, then  $x = a$  is a lower bound for the negative zeros. A “nonpositive” number is 0 or negative, and a “nonnegative” number is 0 or positive.

To determine whether a positive number  $x = b$  is an upper bound for the positive zeros, again we need to use synthetic division. If the numbers on the bottom row are all nonnegative, then  $x = b$  is an upper bound on the positive zeros.

## EXAMPLES

Show that the given values for  $a$  and  $b$  are lower, and upper bounds, respectively, for the following polynomials.

- $f(x) = x^4 + x^3 - 16x^2 - 4x + 48$ ;  $a = -5$  and  $b = 5$

$$\begin{array}{r|rrrrr} -5 & 1 & 1 & -16 & -4 & 48 \\ & & -5 & 20 & -20 & 120 \\ \hline & 1 & -4 & 4 & -24 & 168 \end{array}$$

The bottom row alternates between positive and negative numbers, so  $a = -5$  is a lower bound for the negative zeros of  $f(x)$ .

$$\begin{array}{r|rrrrr} 5 & 1 & 1 & -16 & -4 & 48 \\ & & 5 & 30 & 70 & 330 \\ \hline & 1 & 6 & 14 & 66 & 378 \end{array}$$

The entries on the bottom row are all positive, so  $b = 5$  is an upper bound for the positive zeros of  $f(x)$ . All of the real zeros for  $f(x)$  are between  $x = -5$  and  $x = 5$ .

If 0 appears on the bottom row when testing for an upper bound, we can consider 0 to be positive. If 0 appears in the bottom row when testing for a lower bound, we can consider 0 to be negative if the previous entry is positive and positive if the previous entry is negative. In other words, consider 0 to be the opposite sign as the previous entry.

- $P(x) = 4x^4 + 20x^3 + 7x^2 + 3x - 6$  with  $a = -5$

$$\begin{array}{r|rrrrr} -5 & 4 & 20 & 7 & 3 & -6 \\ & & -20 & 0 & -35 & 160 \\ \hline & 4 & 0 & 7 & -32 & 154 \end{array}$$

Because 0 follows a positive number, we will consider 0 to be negative. This makes the bottom row alternate between positive and negative entries, so  $a = -5$  is a lower bound for the negative zeros of  $P(x)$ .

The Upper and Lower Bounds Theorem has some limitations. For instance, it does not tell us *how* to find upper and lower bounds for the zeros of a polynomial. For any polynomial, there are infinitely many upper and lower bounds. For instance, if  $x = 5$  is an upper bound, then any number larger than 5 is also an upper bound. For many polynomials, a starting place is the quotient of the constant term and the leading coefficient and its negative:  $\pm \frac{\text{constant term}}{\text{leading coefficient}}$ . First show that these are bounds for the zeros, then work your way inward. For example, if  $f(x) = 2x^3 - 7x^2 + x + 50$ , let  $a = -\frac{50}{2} = -25$  and  $b = \frac{50}{2} = 25$ . Then, let  $a$  and  $b$  get closer together, say  $a = -10$  and  $b = 10$ .

## PRACTICE

1. List the candidates for rational zeros. Do not try to find the zeros.  $f(x) = 3x^4 + 8x^3 - 11x^2 + 3x + 4$

- List the candidates for rational zeros. Do not try to find the zeros.  $P(x) = 6x^4 - 24$
- Completely factor  $h(x) = 2x^3 + 5x^2 - 23x + 10$ .
- Completely factor  $P(x) = 7x^3 + 26x^2 - 15x + 2$ .
- Use Descartes' Rule of Signs to count the possible number of positive zeros and the possible number of negative zeros of  $f(x) = 2x^4 - 6x^3 - x^2 + 4x - 8$ .
- Use Descartes' Rule of Signs to count the possible number of positive zeros and the possible number of negative zeros of  $f(x) = -x^3 - x^2 + x + 1$ .
- Show that the given values for  $a$  and  $b$  are lower and upper, respectively, bounds for the zeros of  $f(x) = x^3 - 6x^2 + x + 5$ ;  $a = -3$ ,  $b = 7$ .
- Show that the given values for  $a$  and  $b$  are lower and upper, respectively, bounds for the zeros of  $f(x) = x^4 - x^2 - 2$ ;  $a = -2$ ,  $b = 2$ .
- Sketch the graph for  $g(x) = x^3 - x^2 - 17x - 15$ .

## SOLUTIONS

- Possible numerators:  $\pm 1$ ,  $\pm 2$ ,  $\pm 4$

Possible denominators: 1 and 3

Possible rational zeros:  $\pm 1$ ,  $\pm 2$ ,  $\pm 4$ ,  $\pm \frac{1}{3}$ ,  $\pm \frac{2}{3}$ ,  $\pm \frac{4}{3}$

- Possible numerators:  $\pm 1$ ,  $\pm 2$ ,  $\pm 3$ ,  $\pm 4$ ,  $\pm 6$ ,  $\pm 8$ ,  $\pm 12$ ,  $\pm 24$

Possible denominators: 1, 2, 3, 6

Possible rational zeros (with duplicates omitted):  $\pm 1$ ,  $\pm 2$ ,  $\pm 3$ ,  $\pm 4$ ,  $\pm 6$ ,  $\pm 8$ ,  $\pm 12$ ,  $\pm 24$ ,  $\pm \frac{1}{2}$ ,  $\pm \frac{3}{2}$ ,  $\pm \frac{1}{3}$ ,  $\pm \frac{2}{3}$ ,  $\pm \frac{4}{3}$ ,  $\pm \frac{8}{3}$ ,  $\pm \frac{1}{6}$

- The possible rational zeros are  $\pm 1$ ,  $\pm 2$ ,  $\pm 5$ ,  $\pm 10$ ,  $\pm \frac{1}{2}$ , and  $\pm \frac{5}{2}$ . Because  $h(2) = 0$ ,  $x = 2$  is a zero of  $h(x)$ .

$$\begin{array}{r|rrrr} 2 & 2 & 5 & -23 & 10 \\ & & 4 & 18 & -10 \\ \hline & 2 & 9 & -5 & 0 \end{array}$$

$$h(x) = (x - 2)(2x^2 + 9x - 5)$$

$$h(x) = (x - 2)(2x - 1)(x + 5)$$

- The possible rational zeros are  $\pm 1$ ,  $\pm 2$ ,  $\pm \frac{1}{7}$ , and  $\pm \frac{2}{7}$ . Because  $P(\frac{2}{7}) = 0$ ,  $x = \frac{2}{7}$  is a zero for  $P(x)$ .



$$\begin{array}{r} \frac{2}{7} \overline{) 7 \quad 26 \quad -15 \quad 2} \\ \underline{\phantom{2} 7 \quad 28 \quad -7 \quad 0} \phantom{0} \end{array}$$

$$\begin{aligned} P(x) &= \left(x - \frac{2}{7}\right)(7x^2 + 28x - 7) \\ &= \left(x - \frac{2}{7}\right)(7)(x^2 + 4x - 1) = \left[7\left(x - \frac{2}{7}\right)\right](x^2 + 4x - 1) \\ &= (7x - 2)(x^2 + 4x - 1) \end{aligned}$$

We will use the quadratic formula to find the zeros for  $x^2 + 4x - 1$ .

$$\begin{aligned} x &= \frac{-4 \pm \sqrt{4^2 - 4(1)(-1)}}{2(1)} = \frac{-4 \pm \sqrt{20}}{2} \\ &= \frac{-4 \pm 2\sqrt{5}}{2} = \frac{2(-2 \pm \sqrt{5})}{2} \\ &= -2 \pm \sqrt{5} = -2 + \sqrt{5}, \quad -2 - \sqrt{5} \end{aligned}$$

$$\begin{aligned} x^2 + 4x - 1 &= (x - (-2 + \sqrt{5}))(x - (-2 - \sqrt{5})) \\ &= (x + 2 - \sqrt{5})(x + 2 + \sqrt{5}) \end{aligned}$$

$$P(x) = (7x - 2)(x + 2 - \sqrt{5})(x + 2 + \sqrt{5})$$

5. There are 3 sign changes in  $f(x)$ , so there are 3 or 1 positive zeros.

$$\begin{aligned} f(-x) &= 2(-x)^4 - 6(-x)^3 - (-x)^2 + 4(-x) - 8 \\ &= 2x^4 + 6x^3 - x^2 - 4x - 8 \end{aligned}$$

There is 1 sign change in  $f(-x)$ , so there is exactly 1 negative zero.

6. There is 1 sign change in  $f(x)$ , so there is exactly 1 positive zero.

$$\begin{aligned} f(-x) &= -(-x)^3 - (-x)^2 + (-x) + 1 \\ &= x^3 - x^2 - x + 1 \end{aligned}$$

There are 2 sign changes in  $f(-x)$ , so there are 2 or 0 negative zeros.

$$7. \quad \begin{array}{r} -3 \overline{) 1 \quad -6 \quad 1 \quad 5} \\ \underline{1 \quad -9 \quad 28 \quad -79} \end{array}$$

The entries on the bottom row alternate between positive and negative (or nonnegative and nonpositive), so  $a = -3$  is a lower bound for the zeros of  $f(x)$ .

$$7 \overline{) 1 \quad -6 \quad 1 \quad 5} \\ \underline{7 \quad 7 \quad 56} \\ 1 \quad 1 \quad 8 \quad 61$$

The entries on the bottom are positive (nonnegative), so  $b = 7$  is an upper bound for the positive zeros of  $f(x)$ .

$$8. \quad \begin{array}{r} -2 \overline{) 1 \quad 0 \quad -1 \quad 0 \quad -2} \\ \underline{-2 \quad 4 \quad -6 \quad 12} \\ 1 \quad -2 \quad 3 \quad -6 \quad 10 \end{array}$$

The entries on the bottom row alternate between positive and negative, so  $a = -2$  is a lower bound for the negative zeros of  $f(x)$ .

$$2 \overline{) 1 \quad 0 \quad -1 \quad 0 \quad -2} \\ \underline{2 \quad 4 \quad 6 \quad 12} \\ 1 \quad 2 \quad 3 \quad 6 \quad 10$$

The entries on the bottom row are all positive, so  $b = 2$  is an upper bound for the positive zeros of  $f(x)$ .

9. The  $x$ -intercepts are  $-3$ ,  $-1$ , and  $5$ . We will plot points for  $x = -3.5$ ,  $x = -2$ ,  $x = 0$ ,  $x = 3$ , and  $x = 5.5$ .

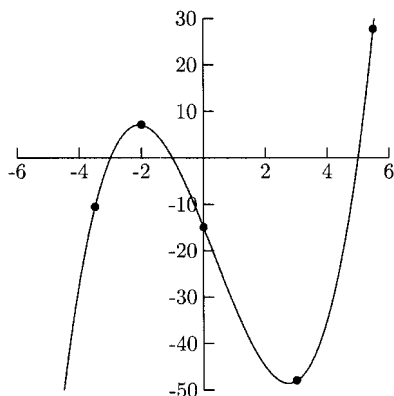

Fig. 7.14.

## Complex Numbers

Until now, zeros of polynomials have been real numbers. The next topic involves *complex* zeros. These zeros come from even roots of negative numbers like  $\sqrt{-1}$ . Before working with complex zeros of polynomials, we will first learn some complex number arithmetic. Complex numbers are normally written in the form  $a + bi$ , where  $a$  and  $b$  are real numbers and  $i = \sqrt{-1}$ . A number such as  $4 + \sqrt{-9}$  would be written as  $4 + 3i$  because  $\sqrt{-9} = \sqrt{9}\sqrt{-1} = 3i$ . Real numbers are complex numbers where  $b = 0$ .

### EXAMPLES

Write the complex numbers in the form  $a + bi$ , where  $a$  and  $b$  are real numbers.

- $\sqrt{-64} = \sqrt{64}\sqrt{-1} = 8i$
- $\sqrt{-27} = \sqrt{27}\sqrt{-1} = \sqrt{27}i = \sqrt{9 \cdot 3}i = \sqrt{9}\sqrt{3}i$   
 $= 3\sqrt{3}i$  Be careful,  $\sqrt{3i} \neq \sqrt{3}i$ .
- $6 + \sqrt{-8} = 6 + \sqrt{8}i = 6 + \sqrt{4 \cdot 2}i = 6 + \sqrt{4}\sqrt{2}i = 6 + 2\sqrt{2}i$

Adding complex numbers is a matter of adding like terms. Add the real parts,  $a$  and  $c$ , and the imaginary parts,  $b$  and  $d$ .

$$(a + bi) + (c + di) = (a + c) + (b + d)i$$

Subtract two complex numbers by distributing the minus sign in the parentheses then adding the like terms.

$$a + bi - (c + di) = a + bi - c - di = (a - c) + (b - d)i$$

### EXAMPLES

Perform the arithmetic. Write the sum or difference in the form  $a + bi$ , where  $a$  and  $b$  are real numbers.

- $(3 - 5i) + (4 + 8i) = (3 + 4) + (-5 + 8)i = 7 + 3i$
- $2i - 6 + 9i = -6 + 11i$
- $7 - \sqrt{-18} + 3 + 5\sqrt{-2} = 7 - \sqrt{18}i + 3 + 5\sqrt{2}i$   
 $= 7 - \sqrt{9 \cdot 2}i + 3 + 5\sqrt{2}i = 7 - 3\sqrt{2}i + 3 + 5\sqrt{2}i$   
 $= 10 + 2\sqrt{2}i$
- $11 - 3i - (7 + 6i) = 11 - 3i - 7 - 6i = 4 - 9i$

$$\begin{aligned} \bullet \quad 7 + \sqrt{-8} - (1 - \sqrt{-18}) &= 7 + \sqrt{8}i - 1 + \sqrt{18}i \\ &= 7 + 2\sqrt{2}i - 1 + 3\sqrt{2}i = 6 + 5\sqrt{2}i \end{aligned}$$

Multiplying complex numbers is not as straightforward as adding and subtracting them. First we will take the product of two purely imaginary numbers (numbers whose real parts are 0). Remember that  $i = \sqrt{-1}$ , which makes  $i^2 = -1$ . In most complex number multiplication problems, we will have a term with  $i^2$ . Replace  $i^2$  with  $-1$ . Multiply two complex numbers in the form  $a + bi$  using the FOIL method, substituting  $-1$  for  $i^2$  and combining like terms.

## EXAMPLES

Write the product in the form  $a + bi$ , where  $a$  and  $b$  are real numbers.

- $(5i)(6i) = 30i^2 = 30(-1) = -30$
- $(2i)(-9i) = -18i^2 = -18(-1) = 18$
- $(\sqrt{-6})(\sqrt{-9}) = (\sqrt{6}i)(\sqrt{9}i) = (\sqrt{6})(3)i^2 = 3\sqrt{6}(-1) = -3\sqrt{6}$
- $(4 + 2i)(5 + 3i) = 20 + 12i + 10i + 6i^2 = 20 + 22i + 6(-1) = 14 + 22i$
- $(8 - 2i)(8 + 2i) = 64 + 16i - 16i - 4i^2 = 64 - 4(-1) = 68$

The complex numbers  $a + bi$  and  $a - bi$  are called *complex conjugates*. The only difference between a complex number and its conjugate is the sign between the real part and the imaginary part. The product of any complex number and its conjugate is a real number.

$$\begin{aligned} (a + bi)(a - bi) &= a^2 - abi + abi - b^2i^2 \\ &= a^2 - b^2(-1) \\ &= a^2 + b^2 \end{aligned}$$

## EXAMPLES

- The complex conjugate of  $3 + 2i$  is  $3 - 2i$ .
- The complex conjugate of  $-7 - i$  is  $-7 + i$ .
- The complex conjugate of  $10i$  is  $-10i$ .
- $(7 - 2i)(7 + 2i)$ . Here,  $a = 7$  and  $b = 2$ , so  $a^2 = 49$  and  $b^2 = 4$ , making  $(7 - 2i)(7 + 2i) = 49 + 4 = 53$ .
- $(1 - i)(1 + i)$ . Here  $a = 1$  and  $b = 1$ , so  $a^2 = 1$  and  $b^2 = 1$ , making  $(1 - i)(1 + i) = 1 + 1 = 2$ .

Dividing two complex numbers can be a little complicated. These problems are normally written in fraction form. If the denominator is purely imaginary, we can simply multiply the fraction by  $\frac{i}{i}$  and simplify.

## EXAMPLES

Perform the division. Write the quotient in the form  $a + bi$ , where  $a$  and  $b$  are real numbers.

$$\begin{aligned} \bullet \quad \frac{2 + 3i}{i} &= \frac{2 + 3i}{i} \cdot \frac{i}{i} = \frac{(2 + 3i)i}{i^2} \\ &= \frac{2i + 3i^2}{i^2} = \frac{2i + 3(-1)}{-1} \\ &= \frac{-3 + 2i}{-1} = -(-3 + 2i) \\ &= 3 - 2i \end{aligned}$$

$$\begin{aligned} \bullet \quad \frac{4 + 5i}{2i} &= \frac{4 + 5i}{2i} \cdot \frac{i}{i} = \frac{4i + 5i^2}{2i^2} \\ &= \frac{4i + 5(-1)}{2(-1)} \\ &= \frac{4i - 5}{-2} = \frac{-(4i - 5)}{2} = \frac{-(-5 + 4i)}{2} \\ &= \frac{5 - 4i}{2} = \frac{5}{2} - 2i \end{aligned}$$

When the divisor (denominator) is in the form  $a + bi$ , multiplying the fraction by  $\frac{i}{i}$  will not work.

$$\frac{2 - 5i}{3 + 6i} \cdot \frac{i}{i} = \frac{2i - 5i^2}{3i + 6i^2} = \frac{5 + 2i}{-6 + 3i}$$

What *does* work is to multiply the fraction by the denominator's conjugate over itself. This works because the product of any complex number and its conjugate is a real number. We will use the FOIL method in the numerator (if necessary) and the fact that  $(a + bi)(a - bi) = a^2 + b^2$  in the denominator.

## EXAMPLES

Write the quotient in the form  $a + bi$ , where  $a$  and  $b$  are real numbers.

- $$\begin{aligned} \frac{2 + 7i}{6 + i} &= \frac{2 + 7i}{6 + i} \cdot \frac{6 - i}{6 - i} = \frac{12 - 2i + 42i - 7i^2}{6^2 + 1^2} \\ &= \frac{12 + 40i - 7(-1)}{37} = \frac{12 + 40i + 7}{37} \\ &= \frac{19 + 40i}{37} = \frac{19}{37} + \frac{40}{37}i \end{aligned}$$
- $$\begin{aligned} \frac{4 - 9i}{5 - 2i} &= \frac{4 - 9i}{5 - 2i} \cdot \frac{5 + 2i}{5 + 2i} = \frac{20 + 8i - 45i - 18i^2}{5^2 + 2^2} \\ &= \frac{20 - 37i - 18(-1)}{25 + 4} = \frac{20 - 37i + 18}{29} \\ &= \frac{38 - 37i}{29} = \frac{38}{29} - \frac{37}{29}i \end{aligned}$$

There are reasons to write complex numbers in the form  $a + bi$ . One is that complex numbers are plotted in the plane (real numbers are plotted on the number line), where the  $x$ -axis becomes the *real* axis and the  $y$ -axis becomes the *imaginary* axis. The number  $3 - 4i$  is plotted in Figure 7.15.

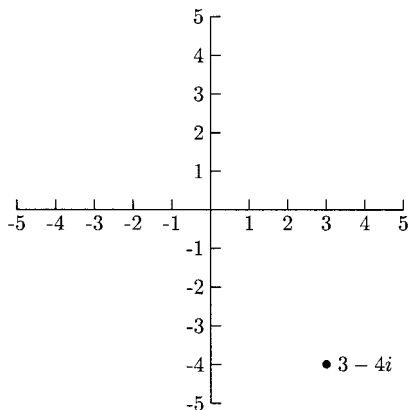

Fig. 7.15.

**PRACTICE**

For Problems 1–3, write the complex number in the form  $a + bi$ , where  $a$  and  $b$  are real numbers.

1.  $\sqrt{-25}$
2.  $\sqrt{-24}$
3.  $14 - \sqrt{-36}$

For Problems 4–15, perform the arithmetic. Write answers in the form  $a + bi$ , where  $a$  and  $b$  are real numbers.

4.  $18 - 4i + (-15) + 2i$
5.  $5 + i + 5 - i$
6.  $7 + i + 12 + i$
7.  $-5 + \sqrt{-12} + 7 + 4\sqrt{-12}$
8.  $\sqrt{-48} - (-1 - \sqrt{-75})$
9.  $(2i)(10i)$
10.  $(4\sqrt{-25})(2\sqrt{-25})$
11.  $\sqrt{-6} \cdot \sqrt{-15}$
12.  $(15 + 3i)(-2 + i)$
13.  $(3 + 2i)(3 - 2i)$
14.  $(8 - 10i)(8 + 10i)$
15.  $(1 - 9i)(1 + 9i)$

For Problems 16–18, identify the complex conjugate.

16.  $15 + 7i$
17.  $-3 + i$
18.  $-9i$

For Problems 19–21, write the quotient in the form  $a + bi$ , where  $a$  and  $b$  are real numbers.

19.  $\frac{4-9i}{-3i}$
20.  $\frac{4+2i}{1-3i}$
21.  $\frac{6+4i}{6-4i}$

## SOLUTIONS

1.  $\sqrt{-25} = \sqrt{25}i = 5i$
2.  $\sqrt{-24} = \sqrt{24}i = \sqrt{4 \cdot 6}i = 2\sqrt{6}i$
3.  $14 - \sqrt{-36} = 14 - \sqrt{36}i = 14 - 6i$
4.  $18 - 4i + (-15) + 2i = 3 - 2i$
5.  $5 + i + 5 - i = 10 + 0i = 10$
6.  $7 + i + 12 + i = 19 + 2i$
7.  $-5 + \sqrt{-12} + 7 + 4\sqrt{-12} = -5 + \sqrt{12}i + 7 + 4\sqrt{12}i$   
 $= -5 + \sqrt{4 \cdot 3}i + 7 + 4\sqrt{4 \cdot 3}i$   
 $= -5 + 2\sqrt{3}i + 7 + 4 \cdot 2\sqrt{3}i$   
 $= -5 + 2\sqrt{3}i + 7 + 8\sqrt{3}i$   
 $= 2 + 10\sqrt{3}i$
8.  $\sqrt{-48} - (-1 - \sqrt{-75}) = \sqrt{48}i + 1 + \sqrt{75}i$   
 $= \sqrt{16 \cdot 3}i + 1 + \sqrt{25 \cdot 3}i$   
 $= 4\sqrt{3}i + 1 + 5\sqrt{3}i = 1 + 9\sqrt{3}i$
9.  $(2i)(10i) = 20i^2 = 20(-1) = -20$
10.  $(4\sqrt{-25})(2\sqrt{-25}) = 4(5i)[2(5i)] = 200i^2 = 200(-1) = -200$
11.  $\sqrt{-6} \cdot \sqrt{-15} = \sqrt{6i} \cdot \sqrt{15i} = \sqrt{6 \cdot 15}i^2 = \sqrt{90}i^2 = 3\sqrt{10}(-1)$   
 $= -3\sqrt{10}$
12.  $(15 + 3i)(-2 + i) = -30 + 15i - 6i + 3i^2 = -30 + 9i + 3(-1) = -33 + 9i$
13.  $(3 + 2i)(3 - 2i) = 9 - 6i + 6i - 4i^2 = 9 - 4(-1) = 13$  (or  $3^2 + 2^2 = 13$ )
14.  $(8 - 10i)(8 + 10i) = 64 + 80i - 80i - 100i^2 = 64 - 100(-1) = 164$   
 (or  $8^2 + 10^2 = 164$ )
15.  $(1 - 9i)(1 + 9i) = 1 + 9i - 9i - 81i^2 = 1 - 81(-1) = 82$  (or  $1^2 + 9^2 = 82$ )
16. The complex conjugate of  $15 + 7i$  is  $15 - 7i$ .
17. The complex conjugate of  $-3 + i$  is  $-3 - i$ .
18. The complex conjugate of  $-9i$  is  $9i$ .
19.  $\frac{4 - 9i}{-3i} = \frac{4 - 9i}{-3i} \cdot \frac{i}{i} = \frac{4i - 9i^2}{-3i^2}$   
 $= \frac{4i - 9(-1)}{-3(-1)} = \frac{9 + 4i}{3} = 3 + \frac{4}{3}i$



$$\begin{aligned}
 20. \quad \frac{4+2i}{1-3i} &= \frac{4+2i}{1-3i} \cdot \frac{1+3i}{1+3i} = \frac{4+12i+2i+6i^2}{1^2+3^2} \\
 &= \frac{4+14i+6(-1)}{10} = \frac{-2+14i}{10} = -\frac{1}{5} + \frac{7}{5}i
 \end{aligned}$$

$$\begin{aligned}
 21. \quad \frac{6+4i}{6-4i} &= \frac{6+4i}{6-4i} \cdot \frac{6+4i}{6+4i} = \frac{36+24i+24i+16i^2}{6^2+4^2} \\
 &= \frac{36+48i+16(-1)}{36+16} = \frac{20+48i}{52} = \frac{5}{13} + \frac{12}{13}i
 \end{aligned}$$

## Complex Solutions to Quadratic Equations

Every quadratic equation has a solution, real or complex. The real solutions for a quadratic equation are the  $x$ -intercepts, for the graph of the quadratic function.

The graph for  $f(x) = x^2 + 1$  has no  $x$ -intercepts.

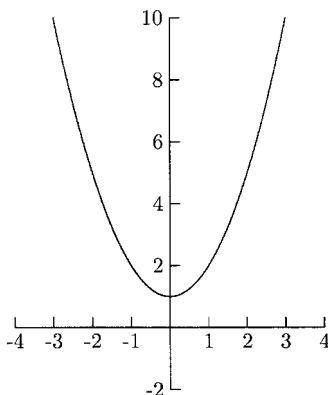

Fig. 7.16.

The equation  $x^2 + 1 = 0$  does have two complex solutions.

$$x^2 + 1 = 0$$

$$x^2 = -1$$

$$x = \pm\sqrt{-1}$$

$$= \pm i$$

**EXAMPLE**

Solve the equation and write the solutions in the form  $a + bi$ , where  $a$  and  $b$  are real numbers.

- $3x^2 + 8x + 14 = 0$

$$\begin{aligned} x &= \frac{-8 \pm \sqrt{8^2 - 4(3)(14)}}{2(3)} = \frac{-8 \pm \sqrt{-104}}{6} \\ &= \frac{-8 \pm 2\sqrt{26}i}{6} = \frac{2(-4 \pm \sqrt{26}i)}{6} \\ &= \frac{-4 \pm \sqrt{26}i}{3} = -\frac{4}{3} \pm \frac{\sqrt{26}}{3}i \\ &= -\frac{4}{3} + \frac{\sqrt{26}}{3}i, \quad -\frac{4}{3} - \frac{\sqrt{26}}{3}i \end{aligned}$$

In this problem, the complex solutions to the quadratic equation came in conjugate pairs. This always happens when the solutions are complex numbers. A quadratic expression that has complex zeros is called *irreducible* (over the reals) because it cannot be factored using real numbers. For example, the polynomial function  $f(x) = x^4 - 1$  can be factored using real numbers as  $(x^2 - 1)(x^2 + 1) = (x - 1)(x + 1)(x^2 + 1)$ . The factor  $x^2 + 1$  is irreducible because it is factored as  $(x - i)(x + i)$ .

We can tell which quadratic factors are irreducible without having to use the quadratic formula. We only need part of the quadratic formula,  $b^2 - 4ac$ . When this number is negative, the quadratic factor has two complex zeros,  $\frac{-b \pm \sqrt{\text{negative number}}}{2a}$ . When this number is positive, there are two real number solutions,  $\frac{-b \pm \sqrt{\text{positive number}}}{2a}$ . When this number is zero, there is one real zero,  $\frac{-b \pm \sqrt{0}}{2a} = \frac{-b}{2a}$ . For this reason,  $b^2 - 4ac$  is called the *discriminant*.

The graphs of some polynomials having irreducible quadratic factors need extra points plotted to get a more accurate graph. The graph in Figure 7.17 shows the graph of  $f(x) = x^4 - 3x^2 - 4$  using our usual method—plotting the  $x$ -intercepts, a point to the left of the smallest  $x$ -intercept, a point between each consecutive pair of  $x$ -intercepts, and a point to the right of the largest  $x$ -intercept.

See what happens to the graph when we plot the points for  $x = 1$  and  $x = -1$ .

The graph of  $f(x) = (x - 2)(x^2 + 6x + 10)$  is sketched in Figure 7.19. The graphs we have sketched have several vertices between  $x$ -intercepts. When this happens, we need calculus to find them.

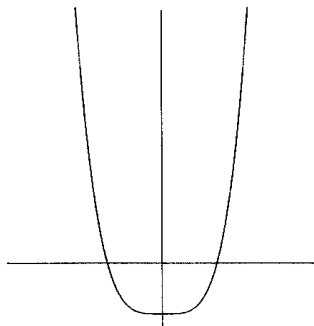

Fig. 7.17.

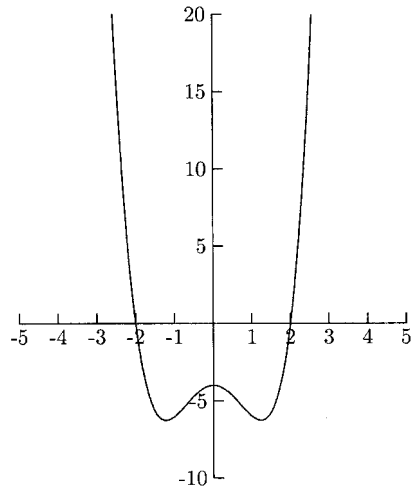

Fig. 7.18.

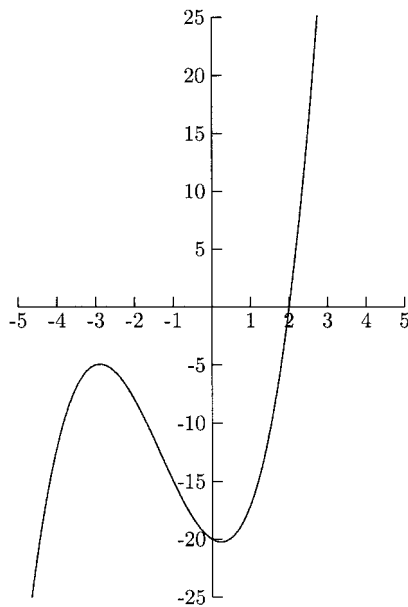

Fig. 7.19.

## The Fundamental Theorem of Algebra

By the *Fundamental Theorem of Algebra*, every polynomial of degree  $n$  has exactly  $n$  zeros (some might be counted more than once). Because  $x = c$  is a zero implies  $x - c$  is a factor, every polynomial can be completely factored in the form  $a(x - c_n)(x - c_{n-1}) \dots (x - c_1)$ , where  $a$  is a real number and  $c_i$  is real or complex. Factors in the form  $x - c$  are called *linear factors*. Factors such as  $2x + 1$  can be written in the form  $x - c$  by factoring 2:  $2(x + \frac{1}{2})$  or  $2(x - (-\frac{1}{2}))$ .

To completely factor a polynomial, we usually need to first find its zeros. At times, we will use the Rational Zero Theorem, polynomial division, and the quadratic formula.

### EXAMPLES

Find all zeros, real and complex.

- $h(x) = x^4 - 16$

$$x^4 - 16 = (x^2 - 4)(x^2 + 4) = (x - 2)(x + 2)(x^2 + 4)$$

The real zeros are 2 and  $-2$ . We will find the complex zeros by solving  $x^2 + 4 = 0$ .

$$x^2 + 4 = 0$$

$$x^2 = -4$$

$$x = \pm\sqrt{-4} = \pm 2i$$

The complex zeros are  $\pm 2i$ .

- $x^4 + 6x^3 + 9x^2 - 6x - 10$

The possible rational zeros are  $\pm 1$ ,  $\pm 2$ ,  $\pm 5$ , and  $\pm 10$ .  $P(1) = 0$ .

$$\begin{array}{r|rrrrr} 1 & 1 & 6 & 9 & -6 & -10 \\ & & 1 & 7 & 16 & 10 \\ \hline & 1 & 7 & 16 & 10 & 0 \end{array}$$

$$P(x) = (x - 1)(x^3 + 7x^2 + 16x + 10)$$

Because  $x^3 + 7x^2 + 16x + 10$  has no sign changes, there are no positive zeros;  $x = -1$  is a zero for  $x^3 + 7x^2 + 16x + 10$ .

$$\begin{array}{r|rrrr} -1 & 1 & 7 & 16 & 10 \\ & & -1 & -6 & -10 \\ \hline & 1 & 6 & 10 & 0 \end{array}$$

$$P(x) = (x - 1)(x + 1)(x^2 + 6x + 10)$$

Solve  $x^2 + 6x + 10 = 0$  to find the complex zeros.

$$\begin{aligned} x &= \frac{-6 \pm \sqrt{6^2 - 4(1)(10)}}{2(1)} = \frac{-6 \pm \sqrt{-4}}{2} \\ &= \frac{-6 \pm 2i}{2} = \frac{2(-3 \pm i)}{2} = -3 \pm i \end{aligned}$$

The zeros are  $\pm 1, -3 \pm i$ .

If we know a complex number is a zero for a polynomial, we automatically know another zero—the complex conjugate is also a zero. This gives us a quadratic factor for the polynomial. Once we have this computed, we can use long division to find the quotient, which will be another factor of the polynomial. Each time we factor a polynomial, we are closer to finding its zeros.

## EXAMPLES

Find all zeros, real and complex.

- $f(x) = 3x^4 + x^3 + 17x^2 + 4x + 20$  and  $x = 2i$  is a zero.  
Because  $x = 2i$  is a zero, its conjugate,  $-2i$ , is another zero. This tells us that two factors are  $x - 2i$  and  $x + 2i$ .

$$(x - 2i)(x + 2i) = x^2 + 2ix - 2ix - 4i^2 = x^2 - 4(-1) = x^2 + 4$$

We will divide  $f(x)$  by  $x^2 + 4 = x^2 + 0x + 4$ .

$$\begin{array}{r} 3x^2 + x + 5 \\ x^2 + 0x + 4 \overline{) 3x^4 + x^3 + 17x^2 + 4x + 20} \\ \underline{-(3x^4 + 0x^3 + 12x^2)} \phantom{+ 4x + 20} \\ x^3 + 5x^2 + 4x \phantom{+ 20} \\ \underline{-(x^3 + 0x^2 + 4x)} \phantom{+ 20} \\ 5x^2 + 0x + 20 \\ \underline{-(5x^2 + 0x + 20)} \\ 0 \end{array}$$

$$f(x) = (x^2 + 4)(3x^2 + x + 5)$$

Solving  $3x^2 + x + 5 = 0$ , we get the solutions

$$x = \frac{-1 \pm \sqrt{1^2 - 4(3)(5)}}{2(3)} = \frac{-1 \pm \sqrt{-59}}{6} = \frac{-1 \pm \sqrt{59}i}{6}$$

The zeros are  $\pm 2i, \frac{-1 \pm \sqrt{59}i}{6}$ .

- $h(x) = 2x^3 - 7x^2 + 170x - 246$ ,  $x = 1 + 9i$  is a zero.  
 Because  $x = 1 + 9i$  is a zero, we know that  $x = 1 - 9i$  is also a zero. We also know that  $x - (1 + 9i) = x - 1 - 9i$  and  $x - (1 - 9i) = x - 1 + 9i$  are factors. We will multiply these two factors.

$$\begin{aligned} (x - 1 - 9i)(x - 1 + 9i) &= x^2 - x + 9ix - x + 1 - 9i - 9ix + 9i - 81i^2 \\ &= x^2 - 2x + 1 - 81(-1) = x^2 - 2x + 82 \end{aligned}$$

$$\begin{array}{r} 2x - 3 \\ \hline x^2 - 2x + 82 \left| \begin{array}{r} 2x^3 - 7x^2 + 170x - 246 \\ -(2x^3 - 4x^2 + 164x) \\ \hline -3x^2 + 6x - 246 \\ -(-3x^2 + 6x - 246) \\ \hline 0 \end{array} \right. \end{array}$$

$$\begin{aligned} h(x) &= (2x - 3)(x^2 - 2x + 82) \\ \text{The zeros are } &1 \pm 9i \text{ and } \frac{3}{2} \text{ (from } 2x - 3 = 0). \end{aligned}$$

A consequence of the Fundamental Theorem of Algebra is that a polynomial of degree  $n$  will have  $n$  zeros, though not necessarily  $n$  different zeros. For example, the polynomial  $f(x) = (x - 2)^3 = (x - 2)(x - 2)(x - 2)$  has  $x = 2$  as a zero three times. The number of times an  $x$ -value is a zero is called its *multiplicity*. In the above example,  $x = 2$  is a zero with multiplicity 3.

### EXAMPLE

- $f(x) = x^4(x + 3)^2(x - 6)$   
 $x = 0$  is a zero with multiplicity 4 (We can think of  $x^4$  as  $(x - 0)^4$ .)  
 $x = -3$  is a zero with multiplicity 2  
 $x = 6$  is a zero with multiplicity 1

Now, instead of finding the zeros for a given polynomial, we will find a polynomial with the given zeros. Because we will know the zeros, we will know the factors. Once we know the factors of a polynomial, we pretty much know the polynomial.

### EXAMPLES

Find a polynomial with integer coefficients having the given degree and zeros.

- Degree 3 with zeros 1, 2, and 5  
 Because  $x = 1$  is a zero,  $x - 1$  is a factor. Because  $x = 2$  is a zero,  $x - 2$  is a factor. And because  $x = 5$  is a zero,  $x - 5$  is a factor. Such a polynomial

will be of the form  $a(x-1)(x-2)(x-5)$ , where  $a$  is some nonzero number. We will want to choose  $a$  so that the coefficients are integers.

$$\begin{aligned} a(x-1)(x-2)(x-5) &= a(x-1)[(x-2)(x-5)] \\ &= a(x-1)(x^2-7x+10) \\ &= a(x^3-7x^2+10x-x^2+7x-10) \\ &= a(x^3-8x^2+17x-10) \end{aligned}$$

Because the coefficients are already integers, we can let  $a = 1$ . One polynomial of degree three having integer coefficients and 1, 2, and 5 as zeros is  $x^3 - 8x^2 + 17x - 10$ .

- Degree 4 with zeros  $-3, 2 - 5i$ , with  $-3$  a zero of multiplicity 2  
Because  $-3$  is a zero of multiplicity 2,  $(x+3)^2 = x^2 + 6x + 9$  is a factor. Because  $2 - 5i$  is a zero,  $2 + 5i$  is another zero. Another factor of the polynomial is

$$\begin{aligned} (x - (2 - 5i))(x - (2 + 5i)) &= (x - 2 + 5i)(x - 2 - 5i) \\ &= x^2 - 2x - 5ix - 2x + 4 + 10i + 5ix \\ &\quad - 10i - 25i^2 \\ &= x^2 - 4x + 4 - 25(-1) = x^2 - 4x + 29. \end{aligned}$$

The polynomial has the form  $a(x^2 + 6x + 9)(x^2 - 4x + 29)$ , where  $a$  is any real number that makes all coefficients integers.

$$\begin{aligned} a(x^2 + 6x + 9)(x^2 - 4x + 29) &= a(x^4 - 4x^3 + 29x^2 + 6x^3 - 24x^2 \\ &\quad + 174x + 9x^2 - 36x + 261) \\ &= a(x^4 + 2x^3 + 14x^2 + 138x + 261) \end{aligned}$$

Because the coefficients are already integers, we can let  $a = 1$ . One polynomial that satisfies the given conditions is  $x^4 + 2x^3 + 14x^2 + 138x + 261$ .

In the previous problems, there were infinitely many answers because  $a$  could be any integer. In the following problem, there will be exactly one polynomial that satisfies the given conditions. This means that  $a$  will likely be a number other than 1.

- Degree 3 with zeros  $-1$ ,  $-2$ , and  $4$ , where the coefficient for  $x$  is  $-20$

$$\begin{aligned}
 a(x+1)(x+2)(x-4) &= a(x+1)[(x+2)(x-4)] \\
 &= a(x+1)(x^2-2x-8) \\
 &= a(x^3-2x^2-8x+x^2-2x-8) \\
 &= a(x^3-x^2-10x-8) \\
 &= ax^3-ax^2-10ax-8a
 \end{aligned}$$

Because we need the coefficient of  $x$  to be  $-20$ , we need  $-10ax = -20x$ , so we need  $a = 2$  (from  $-10a = -20$ ). The polynomial that satisfies the conditions is  $2x^3 - 2x^2 - 20x - 16$ .

## PRACTICE

For Problems 1–6 solve the equations and write complex solutions in the form  $a + bi$ , where  $a$  and  $b$  are real numbers.

- $9x^2 + 4 = 0$
- $6x^2 + 8x + 9 = 0$
- $x^4 - 81 = 0$
- $x^3 + 13x - 34 = 0$
- $x^4 - x^3 + 8x^2 - 9x - 9 = 0$ ;  $x = -3i$  is a solution.
- $x^3 - 5x^2 + 7x + 13 = 0$ ;  $x = 3 - 2i$  is a solution.

For Problems 7–10 find a polynomial with integer coefficients having the given conditions.

7. Degree 3 with zeros  $0$ ,  $-4$ , and  $6$
8. Degree 4 with zeros  $-1$  and  $6 - 7i$ , where  $x = -1$  has multiplicity 2.
9. Degree 3, zeros  $4$ , and  $\pm 1$ , with leading coefficient 3
10. Degree 4 with zeros  $i$  and  $4i$ , with constant term  $-16$
11. State each zero and its multiplicity for  $f(x) = x^2(x+4)(x+9)^6(x-5)^3$



## SOLUTIONS

1.  $9x^2 + 4 = 0$

$$9x^2 = -4$$

$$x^2 = -\frac{4}{9}$$

$$x = \pm\sqrt{-\frac{4}{9}} = \pm\frac{2}{3}i = \frac{2}{3}i, -\frac{2}{3}i$$

2.  $x = \frac{-8 \pm \sqrt{8^2 - 4(6)(9)}}{2(6)}$

$$= \frac{-8 \pm \sqrt{-152}}{12} = \frac{-8 \pm 2\sqrt{38}i}{12}$$

$$= \frac{2(-4 \pm \sqrt{38}i)}{12} = \frac{-4 \pm \sqrt{38}i}{6}$$

$$= -\frac{4}{6} \pm \frac{\sqrt{38}}{6}i = -\frac{2}{3} \pm \frac{\sqrt{38}}{6}i$$

$$= -\frac{2}{3} + \frac{\sqrt{38}}{6}i, -\frac{2}{3} - \frac{\sqrt{38}}{6}i$$

3.  $x^4 - 81 = (x^2 - 9)(x^2 + 9) = (x - 3)(x + 3)(x^2 + 9)$

$$x^2 + 9 = 0$$

$$x^2 = -9$$

$$x = \pm\sqrt{-9} = \pm 3i$$

The solutions are  $\pm 3, \pm 3i$ .

4.  $x = 2$  is a solution, so  $x - 2$  is a factor of  $x^3 + 13x - 34$ . Using synthetic division, we can find the quotient, which will be another factor.

$$\begin{array}{r|rrrr} 2 & 1 & 0 & 13 & -34 \\ & & 2 & 4 & 34 \\ \hline & 1 & 2 & 17 & 0 \end{array}$$

The quotient is  $x^2 + 2x + 17$ . We will find the other solutions by solving  $x^2 + 2x + 17 = 0$ .

$$x = \frac{-2 \pm \sqrt{2^2 - 4(1)(17)}}{2(1)} = \frac{-2 \pm \sqrt{-64}}{2} = \frac{-2 \pm 8i}{2}$$

$$= \frac{2(-1 \pm 4i)}{2} = -1 \pm 4i$$

The solutions are 2 and  $-1 \pm 4i$ .

5.  $x = -3i$  is a solution, so  $x = 3i$  is a solution, also. One factor of  $x^4 - x^3 + 8x^2 - 9x - 9$  is  $(x - 3i)(x + 3i) = x^2 + 9 = x^2 + 0x + 9$ .

$$\begin{array}{r}
 x^2 - \quad x - \quad 1 \\
 x^2 + 0x + 9 \overline{) \begin{array}{r} x^4 - \quad x^3 + \quad 8x^2 - 9x - 9 \\ -(x^4 + \quad 0x^3 + \quad 9x^2) \\ \hline \quad -x^3 - \quad x^2 - 9x \\ \quad -(-x^3 + \quad 0x^2 - 9x) \\ \hline \quad \quad -x^2 + 0x - 9 \\ \quad \quad -(-x^2 + \quad 0x - 9) \\ \hline \quad \quad \quad \quad 0 \end{array} }
 \end{array}$$

Solve  $x^2 - x - 1 = 0$ .

$$x = \frac{-(-1) \pm \sqrt{(-1)^2 - 4(1)(-1)}}{2(1)} = \frac{1 \pm \sqrt{5}}{2}$$

The solutions are  $\pm 3i, \frac{1 \pm \sqrt{5}}{2}$ .

6.  $x = 3 - 2i$  is a solution, so  $x = 3 + 2i$  is also a solution. One factor of  $x^3 - 5x^2 + 7x + 13$  is

$$\begin{aligned}
 (x - (3 - 2i))(x - (3 + 2i)) &= (x - 3 + 2i)(x - 3 - 2i) \\
 &= x^2 - 3x - 2ix - 3x + 9 + 6i + 2ix - 6i - 4i^2 \\
 &= x^2 - 6x + 9 - 4(-1) = x^2 - 6x + 13.
 \end{aligned}$$

$$\begin{array}{r}
 x + 1 \\
 x^2 - 6x + 13 \overline{) \begin{array}{r} x^3 - \quad 5x^2 + \quad 7x + 13 \\ -(x^3 - \quad 6x^2 + 13x) \\ \hline \quad \quad x^2 - \quad 6x + 13 \\ \quad \quad -(x^2 - \quad 6x + 13) \\ \hline \quad \quad \quad \quad 0 \end{array} }
 \end{array}$$

The solutions are  $3 \pm 2i$  and  $-1$ .

7. One polynomial with integer coefficients, with degree 3 and zeros 0,  $-4$  and 6 is

$$x(x + 4)(x - 6) = x(x^2 - 2x - 24) = x^3 - 2x^2 - 24x.$$

8. One polynomial with integer coefficients, with degree 4 and zeros  $-1$ ,  $6 - 7i$ , where  $x = -1$  has multiplicity 2 is

$$\begin{aligned}(x+1)^2(x-(6-7i))(x-(6+7i)) &= (x+1)^2(x-6+7i)(x-6-7i) \\ &= [(x+1)(x+1)][x^2-6x-7ix-6x+36+42i+7ix-42i-49i^2] \\ &= (x^2+2x+1)(x^2-12x+85) \\ &= x^4-12x^3+85x^2+2x^3-24x^2+170x+x^2-12x+85 \\ &= x^4-10x^3+62x^2+158x+85.\end{aligned}$$

9. The factors are  $x - 4$ ,  $x - 1$ , and  $x + 1$ .

$$\begin{aligned}a(x-4)(x-1)(x+1) &= a(x-4)[(x-1)(x+1)] = a(x-4)(x^2-1) \\ &= a[(x-4)(x^2-1)] = a(x^3-4x^2-x+4) \\ &= ax^3-4ax^2-ax+4a\end{aligned}$$

We want the leading coefficient to be 3, so  $a = 3$ . The polynomial that satisfies the conditions is  $3x^3 - 12x^2 - 3x + 12$ .

10. The factors are  $x + i$ ,  $x - i$ ,  $x - 4i$ , and  $x + 4i$ .

$$\begin{aligned}a(x+i)(x-i)(x-4i)(x+4i) &= a[(x+i)(x-i)][(x-4i)(x+4i)] \\ &= a(x^2+1)(x^2+16) = a(x^4+17x^2+16) \\ &= ax^4+17ax^2+16a\end{aligned}$$

We want  $16a = -16$ , so  $a = -1$ . The polynomial that satisfies the conditions is  $-x^4 - 17x^2 - 16$ .

11.  $x = 0$  is a zero with multiplicity 2.  
 $x = -4$  is a zero with multiplicity 1.  
 $x = -9$  is a zero with multiplicity 6.  
 $x = 5$  is a zero with multiplicity 3.

## CHAPTER 7 REVIEW

1. What are the  $x$ -intercepts of  $f(x) = x^2(x+3)(x-2)$ ?  
 (a)  $-3$  and  $2$     (b)  $3$  and  $-2$     (c)  $0$ ,  $-3$ , and  $2$     (d)  $0$ ,  $3$ , and  $-2$

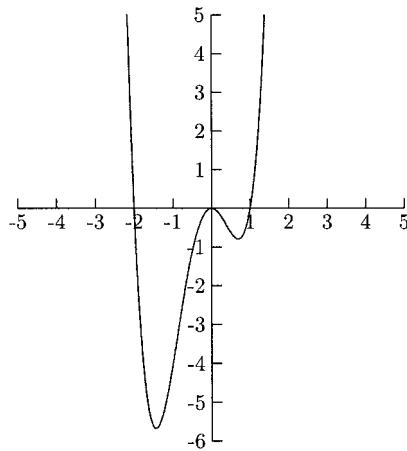

Fig. 7.20.

2. The graph in Figure 7.20 is the graph of which function?

- (a)  $f(x) = 2x^2(x - 1)(x + 2) = 2x^4 + 2x^3 - 4x^2$
- (b)  $f(x) = -2x^2(x - 1)(x + 2) = -2x^4 - 2x^3 + 4x^2$
- (c)  $f(x) = 2x(x - 1)(x + 2) = 2x^3 + 2x^2 - 4x$
- (d)  $f(x) = -2x(x - 1)(x + 2) = -2x^3 - 2x^2 + 4x$

3. What is the quotient and remainder for

$$\frac{x^3 + 1}{x^2 + x + 2}?$$

- (a) The quotient is  $x - 1$ , and the remainder is  $-3x - 3$ .
  - (b) The quotient is  $x - 1$ , and the remainder is  $-x + 3$ .
  - (c) The quotient is  $x + 1$ , and the remainder is  $x + 3$ .
  - (d) The quotient is  $x + 1$ , and the remainder is  $3x + 3$ .
4. Use synthetic division to find the quotient and remainder for  $(2x^3 - x^2 + 2x + 4) \div (x - 3)$ .
- (a) The quotient is  $2x^2 + x + 5$ , and the remainder is 19.
  - (b) The quotient is  $2x^2 + 5x + 7$ , and the remainder is 29.
  - (c) The quotient is  $2x^2 + 5x + 17$ , and the remainder is 55.
  - (d) The quotient is  $2x^2 + x + 3$ , and the remainder is 7.

5. What is the quotient for  $(x^4 + x^3 - 3x + 5) \div (-2x^2 + x - 6)$ ?
- (a) The quotient is  $-\frac{1}{2}x^2 - \frac{1}{4}x - \frac{11}{8}$ .  
 (b) The quotient is  $-\frac{1}{2}x^2 + \frac{1}{4}x + \frac{13}{8}$ .  
 (c) The quotient is  $-\frac{1}{2}x^2 - \frac{3}{4}x - \frac{15}{8}$ .  
 (d) The quotient is  $-\frac{1}{2}x^2 - \frac{3}{4}x + \frac{9}{8}$ .
6. Completely factor  $P(x) = 4x^3 + 4x^2 - x - 1$ .
- (a)  $(x - 1)^2(4x + 1)$                       (b)  $(x + 1)(2x - 1)(2x + 1)$   
 (c)  $(x + 1)^2(4x - 1)$                       (d)  $(x - 1)(2x - 1)(2x + 1)$
7. Find all solutions for  $x^2 + 2x + 4 = 0$ .
- (a)  $-1 \pm \sqrt{3}i$     (b)  $1 \pm \sqrt{3}i$     (c)  $1 \pm \sqrt{5}$     (d)  $-1 \pm \sqrt{5}$
8. What is the quotient for  $\frac{1-i}{2+3i}$ ?
- (a)  $\frac{2}{13}$                       (b)  $\frac{5}{13} + \frac{1}{13}i$     (c)  $\frac{5}{13} - \frac{1}{13}i$     (d)  $-\frac{1}{13} - \frac{5}{13}i$
9. According to the Rational Zero Theorem, which is *NOT* a possible rational zero for  $f(x) = 4x^5 - 6x^3 + 2x^2 - 6x - 9$ ?
- (a)  $-4$                       (b)  $\frac{3}{2}$                       (c)  $3$                       (d)  $-9$
10. According to Descartes' Rule of Signs, how many positive zeros does  $f(x) = 4x^5 - 6x^3 + 2x^2 - 9$  have?
- (a)  $3$                       (b)  $2$  or  $0$                       (c)  $2$                       (d)  $3$  or  $1$
11. Find all zeros for  $f(x) = x^3 - 6x^2 + 13x - 10$ .
- (a)  $-2, 2 \pm i$     (b)  $2, 2 \pm i$     (c)  $2, 1 \pm 2i$     (d)  $-2, 1 \pm 2i$

## SOLUTIONS

1. C      2. A      3. B      4. C      5. D  
 6. B      7. A      8. D      9. A      10. D      11. B

# Rational Functions

A *rational function* is a function that can be written as one polynomial divided by another.

$$f(x) = \frac{P(x)}{Q(x)} = \frac{a_n x^n + a_{n-1} x^{n-1} + \cdots + a_1 x + a_0}{b_m x^m + b_{m-1} x^{m-1} + \cdots + b_1 x + b_0}$$

Polynomial functions are a special kind of rational function whose denominator function is  $Q(x) = 1$ . While the graph of every polynomial function has exactly one  $y$ -intercept, the graph of a rational function might not have a  $y$ -intercept. If it has a  $y$ -intercept, it can be found by setting  $x$  equal to zero. If it has any  $x$ -intercepts, they can be found by setting the numerator equal to zero.

The graphs of rational functions often come in pieces. For every  $x$ -value that causes a zero in the denominator, there will be a break in the graph. If the function is reduced to lowest terms (the numerator and denominator have no common factors), then there will be a *vertical asymptote* at these breaks. The graph rises (or falls) very fast near these asymptotes. The graph in Figure 8.1 is the graph of  $f(x) = \frac{1}{x-1}$ . It has a vertical asymptote at the line  $x = 1$  because  $x = 1$  causes a zero in the denominator.

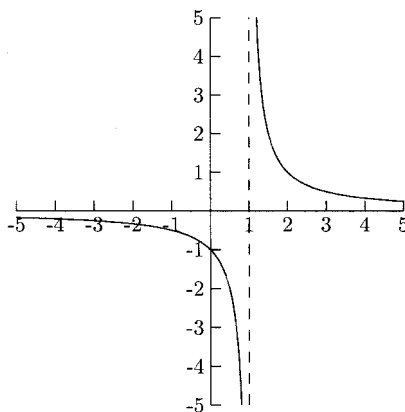

Fig. 8.1.

A vertical asymptote shows that the  $y$ -values get large when the  $x$ -values get close to a zero in the denominator. To see this, we will evaluate  $f(x) = \frac{1}{x-1}$  at  $x = 0.99$  and  $x = 1.01$ , two  $x$ -values close to a zero in the denominator.

$$f(0.99) = \frac{1}{0.99 - 1} = -100 \quad \text{and} \quad f(1.01) = \frac{1}{1.01 - 1} = 100$$

The graph flattens out horizontally near a *horizontal asymptote*. The graph in Figure 8.1 has the  $x$ -axis as its horizontal asymptote. A horizontal asymptote shows that as  $x$  gets very large, the  $y$ -values get very close to a fixed number. In the function  $f(x) = \frac{1}{x-1}$ , there is a horizontal asymptote at  $y = 0$  (the  $x$ -axis). This means that as  $x$  gets large, the  $y$ -values get close to 0.

$$f(100) = \frac{1}{100 - 1} = \frac{1}{99} \approx 0.010101 \text{ and}$$

$$f(-100) = \frac{1}{-100 - 1} = -\frac{1}{101} \approx -0.009901$$

Vertical asymptotes are easy to find—set the denominator equal to zero and solve for  $x$ . Whether or not a graph has a horizontal asymptote depends on the degree of the numerator and of the denominator.

- If the degree of the numerator is larger than the degree of the denominator, there is no horizontal asymptote.
- If the degree of the denominator is larger than the degree of the numerator, there is a horizontal asymptote at  $y = 0$ , which is the  $x$ -axis.

- If the degree of the numerator equals the degree of the denominator, there is a horizontal asymptote at  $y = \frac{a_n}{b_m}$ , where  $a_n$  is the leading coefficient of the numerator and  $b_m$  is the leading coefficient of the denominator.

## EXAMPLES

Find the intercepts, vertical asymptotes, and horizontal asymptotes.

- $f(x) = \frac{x^2 - 16}{3x + 1}$

Solving  $3x + 1 = 0$  we get  $x = -\frac{1}{3}$ . The vertical line  $x = -\frac{1}{3}$  is the vertical asymptote for this graph. There is no horizontal asymptote because the degree of the numerator, 2, is more than the degree of the denominator, 1. The  $x$ -intercepts are  $\pm 4$  (from  $x^2 - 16 = 0$ ) and the  $y$ -intercept is

$$\frac{0^2 - 16}{3(0) + 1} = -16.$$

- $g(x) = \frac{15}{x^2 - 4x - 5}$

When we solve  $x^2 - 4x - 5 = 0$ , we get the solutions  $x = 5, -1$ . This graph has two vertical asymptotes, the vertical lines  $x = 5$  and  $x = -1$ . The  $x$ -axis is the horizontal asymptote because the degree of the numerator, 0, is less than the degree of the denominator, 2. (A reminder, the degree of a constant term is 0,  $15 = 15x^0$ .) There is no  $x$ -intercept because the numerator of this fraction is always 15, it is never 0. The  $y$ -intercept is

$$\frac{15}{0^2 - 4(0) - 5} = -3.$$

- $f(x) = \frac{3x^2}{x^2 + 2}$

Because  $x^2 + 2 = 0$  has no real solutions, this graph has no vertical asymptote. There is a horizontal asymptote at  $y = \frac{3}{1} = 3$  because the degree of the numerator and denominator is the same. The  $x$ -intercept is 0 (from  $3x^2 = 0$ ). The  $y$ -intercept is

$$\frac{3(0)^2}{0^2 + 2} = \frac{0}{2} = 0.$$

The reason we can find the horizontal asymptotes so easily is that for large values of  $x$ , only the leading terms in the numerator and denominator



really matter. The examples below will show an algebraic reason for the rules above. For any fixed number  $c$  any positive power on  $x$ ,

$$\frac{c}{x^{\text{power}}}$$

is almost 0 for large values of  $x$ . For example, in  $\frac{-10}{x^2}$ , if we let  $x$  be any large number, the fraction will be close to 0.

$$\frac{-10}{(100)^2} = -0.001$$

The larger  $x$  is, the closer to 0  $\frac{-10}{x^2}$  is.

## EXAMPLES

- $f(x) = \frac{3x^3 + 5x^2 + x - 6}{2x^4 + 8x^2 - 1}$

From above, we know that the  $x$ -axis, or the horizontal line  $y = 0$ , is a horizontal asymptote. Here is why. Because the highest power on  $x$  is 4, we will multiply the fraction by  $\frac{1/x^4}{1/x^4}$ , which reduces to 1, so we are not changing the fraction.

$$\frac{3x^3 + 5x^2 + x - 6}{2x^4 + 8x^2 - 1} \cdot \frac{1}{x^4} = \frac{\frac{3x^3}{x^4} + \frac{5x^2}{x^4} + \frac{x}{x^4} - \frac{6}{x^4}}{\frac{2x^4}{x^4} + \frac{8x^2}{x^4} - \frac{1}{x^4}} = \frac{\frac{3}{x} + \frac{5}{x^2} + \frac{1}{x^3} - \frac{6}{x^4}}{2 + \frac{8}{x^2} - \frac{1}{x^4}}$$

For large values of  $x$ ,  $3/x$ ,  $5/x^2$ ,  $1/x^3$ ,  $6/x^4$ ,  $8/x^2$ , and  $1/x^4$  are very close to zero, so for large values of  $x$ ,

$$\frac{\frac{3}{x} + \frac{5}{x^2} + \frac{1}{x^3} - \frac{6}{x^4}}{2 + \frac{8}{x^2} - \frac{1}{x^4}} \text{ is close to } \frac{0 + 0 + 0 - 0}{2 + 0 - 0} = \frac{0}{2} = 0.$$

- $g(x) = \frac{4x^3 + 8x^2 - 5x + 3}{9x^3 - x^2 + 8x - 2}$

The degree of the numerator equals the degree of the denominator, so the graph of this function has a horizontal asymptote at the line  $y = 4/9$ . Here is why. Because the largest power on  $x$  is 3, we will multiply the fraction by  $\frac{1/x^3}{1/x^3}$ .

$$\frac{4x^3 + 8x^2 - 5x + 3}{9x^3 - x^2 + 8x - 2} \cdot \frac{1}{x^3} = \frac{\frac{4x^3}{x^3} + \frac{8x^2}{x^3} - \frac{5x}{x^3} + \frac{3}{x^3}}{\frac{9x^3}{x^3} - \frac{x^2}{x^3} - \frac{8x}{x^3} - \frac{2}{x^3}} = \frac{4 + \frac{8}{x} - \frac{5}{x^2} + \frac{3}{x^3}}{9 - \frac{1}{x} - \frac{8}{x^2} - \frac{2}{x^3}}$$

For large values of  $x$ ,  $\frac{4 + \frac{8}{x} - \frac{5}{x^2} + \frac{3}{x^3}}{9 - \frac{1}{x} - \frac{8}{x^2} - \frac{2}{x^3}}$  is close to  $\frac{4 + 0 - 0 + 0}{9 - 0 - 0 - 0} = \frac{4}{9}$ .

These steps are not necessary to find the horizontal asymptotes, only the three rules earlier in the chapter.

## PRACTICE

Find the intercepts, vertical asymptotes, and horizontal asymptotes.

$$1. f(x) = \frac{x + 2}{2x + 3}$$

$$2. g(x) = \frac{-3x}{x^2 + x - 20}$$

$$3. h(x) = \frac{x^2 - 1}{x^2 + 1}$$

$$4. R(x) = \frac{9x^2 - 1}{8x + 3}$$

$$5. f(x) = \frac{x^3 + 1}{x^2 + 4}$$

$$6. f(x) = \frac{2}{x^2}$$

## SOLUTIONS

- The vertical asymptote is  $x = -\frac{3}{2}$ , from  $2x + 3 = 0$ . The horizontal asymptote is  $y = \frac{1}{2}$  because the numerator and denominator have the same degree. The  $x$ -intercept is  $-2$ , from  $x + 2 = 0$ . The  $y$ -intercept is

$$\frac{0 + 2}{2(0) + 3} = \frac{2}{3}.$$

- The vertical asymptotes are  $x = -5$  and  $x = 4$ , from  $x^2 + x - 20 = 0$ . The horizontal asymptote is  $y = 0$  because the denominator has the higher degree. The  $x$ -intercept is  $0$ , from  $-3x = 0$ . The  $y$ -intercept is

$$\frac{-3(0)}{0^2 + 0 - 20} = \frac{0}{-20} = 0.$$

3. There is no vertical asymptote because  $x^2 + 1 = 0$  has no real solution. The horizontal asymptote is  $y = 1/1 = 1$  because the numerator and denominator have the same degree. The  $x$ -intercepts are  $\pm 1$ , from  $x^2 - 1 = 0$ . The  $y$ -intercept is

$$\frac{0^2 - 1}{0^2 + 1} = \frac{-1}{1} = -1.$$

4. The vertical asymptote is  $x = -\frac{3}{8}$ , from  $8x + 3 = 0$ . There is no horizontal asymptote because the numerator has the higher degree. The  $x$ -intercepts are  $\pm\frac{1}{3}$ , from  $9x^2 - 1 = 0$ . The  $y$ -intercept is

$$\frac{9(0)^2 - 1}{8(0) + 3} = \frac{-1}{3}.$$

5. There is no vertical asymptote because  $x^2 + 4 = 0$  has no real solution. There is no horizontal asymptote because the numerator has the higher degree. The  $x$ -intercept is  $-1$ , from  $x^3 + 1 = 0$ . The  $y$ -intercept is

$$\frac{0^3 + 1}{0^2 + 4} = \frac{1}{4}.$$

6. The vertical asymptote is  $x = 0$ , from  $x^2 = 0$ . The horizontal asymptote  $y = 0$  because the denominator has the higher degree. There is no  $x$ -intercept because the numerator is 2, never 0. There is no  $y$ -intercept because  $2/0^2$  is not defined.

When sketching the graph of a rational function, we use dashed lines for the asymptotes. We will sketch the graphs of rational functions in much the same way we sketched the graphs of polynomial functions. In addition to the points we plot for polynomial functions, we need to plot points to illustrate the asymptotic behavior of the graph. To show how a graph behaves near a vertical asymptote, we need to plot a point to its left and to its right. To show how a graph behaves near a horizontal asymptote, we need to plot points with large enough  $x$ -values, both positive and negative, to show how the graph flattens out. When a graph has both horizontal and vertical asymptotes, we will also plot a couple of mid-sized  $x$ -values.

## EXAMPLES

Sketch the graph of the rational function.

- $f(x) = \frac{2x + 1}{x - 4}$

The  $x$ -intercept is  $-\frac{1}{2}$ , the  $y$ -intercept is  $-\frac{1}{4}$ . The vertical asymptote is  $x = 4$ , and the horizontal asymptote is  $y = 2$ . We will use dashed lines for the asymptotes and plot the points for  $x = 3$ ,  $x = 5$ ,  $x = -10$ , and  $x = 10$  to show how the graph behaves near the asymptotes.

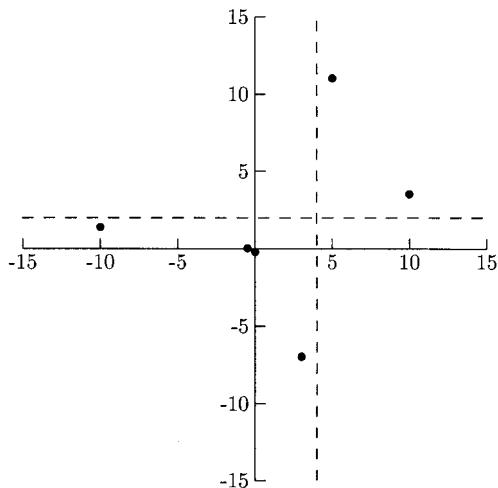

Fig. 8.2.

It is not obvious what the graph looks like so we will plot a point for  $x = 7$ . Then we will draw a smooth curve between the points.

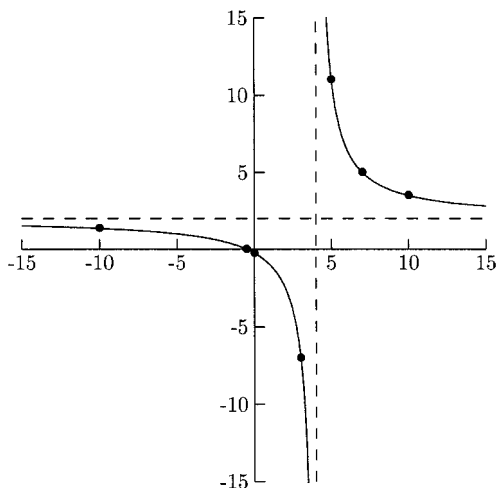

Fig. 8.3.

- $g(x) = \frac{1}{x^2 + 1}$

There is no vertical asymptote because  $x^2 + 1 = 0$  has no real solution. The  $x$ -axis is the horizontal asymptote. This graph has no  $x$ -intercept. The  $y$ -intercept is 1. We will use  $x = 5, -5$  to show the graph's horizontal asymptotic behavior. The function is even, so the left half is a reflection of the right half. We will plot points for  $x = 1, 2$ . The  $y$ -values for  $x = -1, -2$  will be the same.

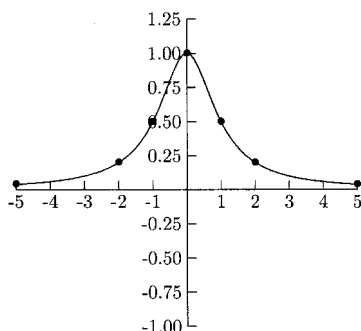

Fig. 8.4.

- $R(x) = \frac{x^2 + 1}{x^2 - 1}$

The vertical asymptotes are  $x = -1$  and  $x = 1$ . The horizontal asymptote is  $y = 1$ . There is no  $x$ -intercept, and the  $y$ -intercept is  $-1$ . We will use  $x = 5, -5$  for the horizontal asymptote and  $x = -0.9, 0.9, -1.1, 1.1$  for the vertical asymptotes. To get a better idea of what the graph looks like, we will need to plot other points. We will use  $x = 2$  and  $x = -2$ .

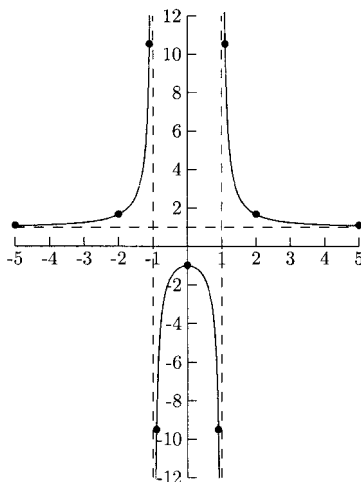

Fig. 8.5.

If the degree of the numerator is exactly one more than the degree of the denominator, then the graph has a *slant asymptote*. We can find the equation of a slant asymptote (a line whose slope is a nonzero number) by performing polynomial division. The equation for the slant asymptote is  $y = \text{quotient}$ .

## EXAMPLES

Find an equation for the slant asymptote.

- $f(x) = \frac{4x^2 + 3x - 5}{x + 2}$

When we divide  $4x^2 + 3x - 5$  by  $x + 2$ , we get a quotient of  $4x - 5$ . The slant asymptote is the line  $y = 4x - 5$ .

$$\begin{array}{r}
 4x - 5 \\
 x + 2 \overline{) 4x^2 + 3x - 5} \\
 \underline{-(4x^2 + 8x)} \phantom{- 5} \\
 -5x - 5 \\
 \underline{-(-5x - 10)} \\
 5
 \end{array}$$

- $f(x) = \frac{x^3 + 2x^2 - 1}{x^2 + x + 2}$

$$\begin{array}{r}
 x + 1 \\
 x^2 + x + 2 \overline{) x^3 + 2x^2 + 0x - 1} \\
 \underline{-(x^3 + x^2 + 2x)} \phantom{- 1} \\
 x^2 - 2x - 1 \\
 \underline{-(x^2 + x + 2)} \\
 -3x - 3
 \end{array}$$

The slant asymptote is  $y = x + 1$ .

When sketching the graph of a rational function that has a slant asymptote, we can show the behavior of the graph near the slant asymptote by plotting points for larger  $x$ -values. We can tell if an  $x$ -value is large enough by checking its  $y$ -values in both the line and rational function. If they are fairly close, then the  $x$ -value is large enough.

## EXAMPLES

Sketch the graph of rational function.

- $f(x) = \frac{x^2 + x - 6}{x + 2}$

### CHAPTER 8 Rational Functions

The  $x$ -intercepts are  $-3$  and  $2$ . The  $y$ -intercept is  $-3$ . The vertical asymptote is  $x = -2$ .

$$-2 \overline{ \begin{array}{r|rr} 1 & 1 & -6 \\ & -2 & 2 \\ \hline 1 & -1 & -4 \end{array} }$$

The quotient is  $x - 1$ , so the slant asymptote is  $y = x - 1$ . We will use  $x = 10$  and  $x = -10$  to show the graph's behavior near the slant asymptote. We will also plot points for  $x = -1$  and  $x = -2.5$  for the vertical asymptote.

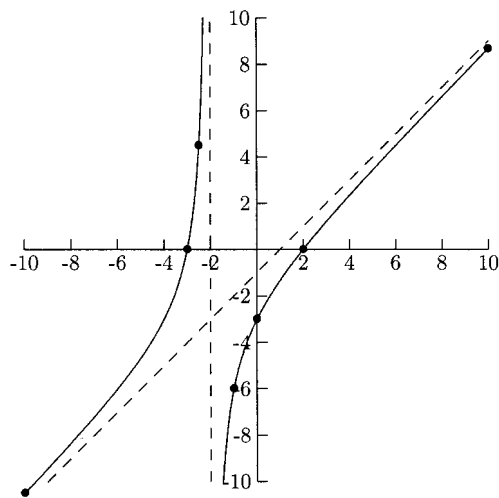

Fig. 8.6.

- $h(x) = \frac{x^3}{x^2 - 1}$

The  $x$ -intercept is  $0$ , the  $y$ -intercept is  $0$ , too. The vertical asymptotes are  $x = -1$  and  $x = 1$ .

$$x^2 + 0x - 1 \overline{ \begin{array}{r|rr} & x & \\ \hline x^3 + & 0x^2 + 0x + 0 \\ -(x^3 + 0x^2 & - x) \\ \hline & & x \end{array} }$$

The quotient is  $x$ , so the slant asymptote is  $y = x$ . We will plot points for  $x = -5$  and  $x = 5$  to show the graph's behavior near the slant asymptote,  $x = -1.1, 1.1, -0.9, 0.9$  for the vertical asymptotes, and  $x = -2, 2$  for in-between points.

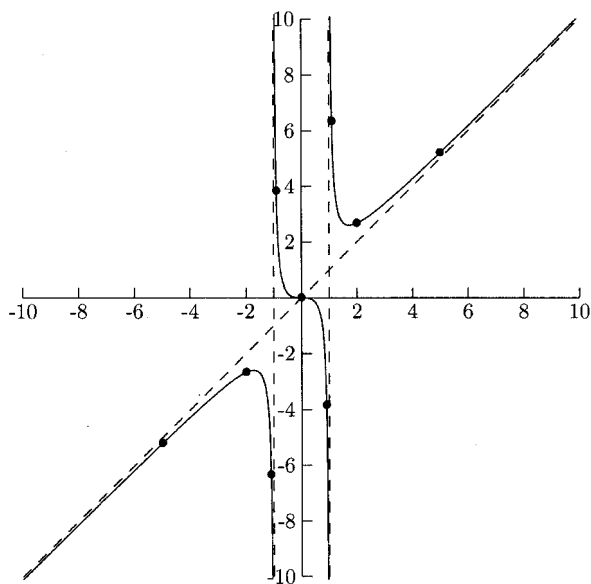

Fig. 8.7.

## PRACTICE

Find the asymptotes and intercepts and sketch the graph.

1.  $f(x) = \frac{1}{x + 2}$

2.  $g(x) = \frac{x}{x^2 - 1}$

3.  $h(x) = \frac{2x - 4}{x + 2}$

4. Hint: Rewrite as one fraction.

$$f(x) = \frac{1}{x} + \frac{1}{x - 2}$$

5.  $f(x) = \frac{x^2 + x - 12}{x - 2}$



## SOLUTIONS

1. The asymptotes are  $x = -2$  and  $y = 0$  (the  $x$ -axis). There is no  $x$ -intercept. The  $y$ -intercept is  $\frac{1}{2}$ .

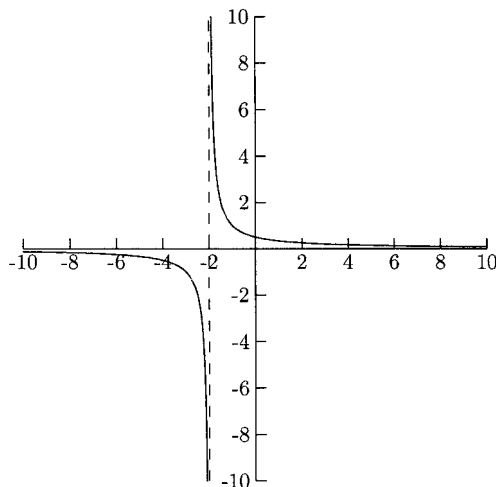

Fig. 8.8.

2. The asymptotes are  $x = -1$ ,  $x = 1$ , and  $y = 0$ . The  $x$ -intercept and  $y$ -intercept is 0.

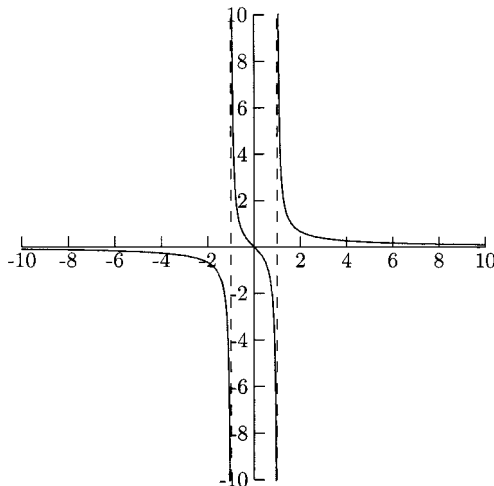

Fig. 8.9.

3. The asymptotes are  $x = -2$  and  $y = 2$ . The  $x$ -intercept is 2, and the  $y$ -intercept is  $-2$ .

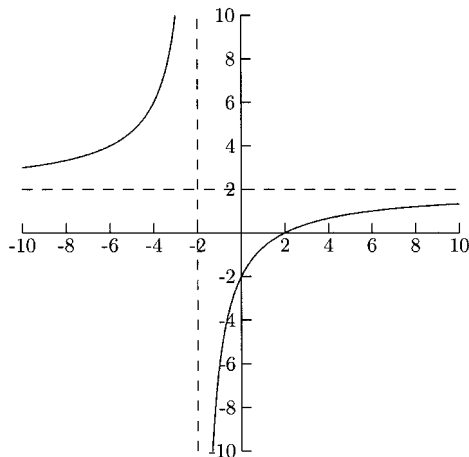

Fig. 8.10.

$$\begin{aligned}
 4. \quad f(x) &= \frac{1}{x} + \frac{1}{x-2} = \frac{1}{x} \cdot \frac{x-2}{x-2} + \frac{1}{x-2} \cdot \frac{x}{x} = \frac{x-2+x}{x(x-2)} \\
 &= \frac{2x-2}{x(x-2)} = \frac{2x-2}{x^2-2x}
 \end{aligned}$$

The asymptotes are  $x = 0$ ,  $x = 2$ , and  $y = 0$ . The  $x$ -intercept is 1, and there is no  $y$ -intercept.

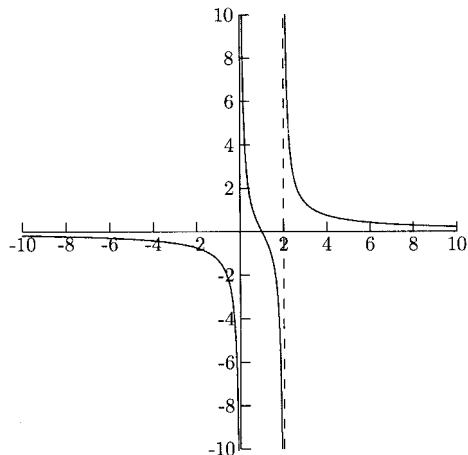

Fig. 8.11.

5. The vertical asymptote is  $x = 2$ . The  $x$ -intercepts are  $-4$  and  $3$ . The  $y$ -intercept is  $6$ . We can use synthetic division to perform polynomial division.

$$\begin{array}{r|rrr} 2 & 1 & 1 & -12 \\ & & 2 & 6 \\ \hline & 1 & 3 & -6 \end{array}$$

The quotient is  $x + 3$ , so the slant asymptote is  $y = x + 3$ .

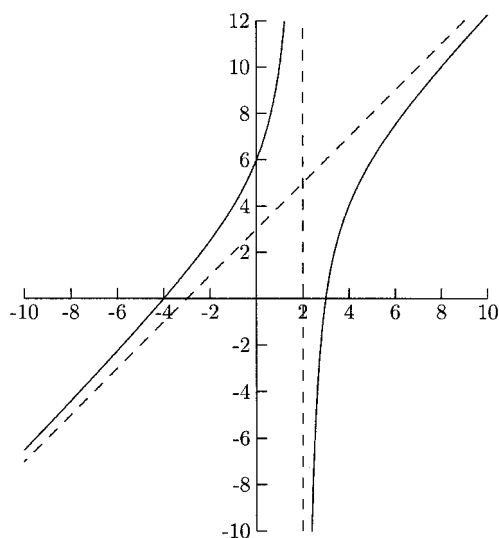

Fig. 8.12.

## CHAPTER 8 REVIEW

1. What is the horizontal asymptote for the graph of

$$f(x) = \frac{2x^4 + 6x - 7}{5x^3 - 8x + 2}?$$

- (a)  $y = 0$       (b)  $y = \frac{2}{5}$       (c) There is no horizontal asymptote.  
 (d) Cannot be determined without the graph.

2. What is the horizontal asymptote for the graph of

$$f(x) = \frac{2x^3 + 6x - 7}{5x^3 - 8x + 2}?$$

- (a)  $y = 0$       (b)  $y = \frac{2}{5}$       (c) There is no horizontal asymptote.  
 (d) Cannot be determined without the graph.
3. What is the horizontal asymptote for the graph of

$$f(x) = \frac{2x^2 + 6x - 7}{5x^3 - 8x + 2}?$$

- (a)  $y = 0$       (b)  $y = \frac{2}{5}$       (c) There is no horizontal asymptote.  
 (d) Cannot be determined without the graph.
4. What is/are the vertical asymptote(s) for the graph of

$$f(x) = \frac{x - 3}{x^2 + x - 2} = \frac{x - 3}{(x + 2)(x - 1)}?$$

- (a)  $x = 3$       (b)  $x = -2$  and  $x = 1$   
 (c)  $x = 3, x = -2,$  and  $x = 1$       (d) There are no vertical asymptotes.
5. What are the intercepts for the graph of

$$f(x) = \frac{x^2 + 1}{x - 4}?$$

- (a) There are no  $x$ -intercepts, and the  $y$ -intercept is  $-\frac{1}{4}$   
 (b) The  $x$ -intercepts are  $\pm 1$ , and the  $y$ -intercept is  $-\frac{1}{4}$   
 (c) The  $x$ -intercepts are  $\pm 1$ , and there is no  $y$ -intercept.  
 (d) There are no intercepts.
6. What is the slant asymptote for the graph of

$$f(x) = \frac{2x^2 + x - 1}{x + 2}?$$

- (a)  $y = 2x + 5$       (b)  $y = 2x - 3$       (c)  $y = 5$   
 (d) There is no slant asymptote.

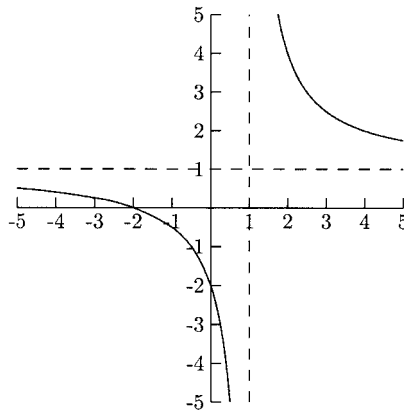

Fig. 8.13.

7. The graph in Figure 8.13 is the graph of which rational function?

(a)  $r(x) = \frac{x - 2}{x + 1}$

(b)  $q(x) = \frac{x - 2}{x - 1}$

(c)  $f(x) = \frac{x + 2}{x - 1}$

(d)  $g(x) = \frac{x + 2}{x + 1}$

## SOLUTIONS

1. C

2. B

3. A

4. B

5. A

6. B

7. C

# Exponents and Logarithms

## Compound Growth

A quantity (such as a population, amount of money, or radiation level) changes *exponentially* if the growth or loss is a fixed percentage over a period of time. To see how this works, we will see how the value of an account grows over four years if \$100 is deposited and earns 5% interest, compounded annually. *Compounded annually* means that the interest earned in the previous year earns interest.

After one year, \$100 has grown to  $100 + 0.05(100) = 100 + 5 = \$105$ . In the second year, the original \$100 earns 5% plus the \$5 earns 5% interest:  $105 + (105)(0.05) = \$110.25$ . Now this amount earns interest in the third year:  $110.25 + (110.25)(0.05) = \$115.76$ . Finally, this amount earns interest in the fourth year:  $115.76 + (115.76)(0.05) = \$121.55$ . If interest is not compounded, that is, the

interest does not earn interest, the account would only be worth \$120. The extra \$1.55 is interest earned on interest.

Compound growth is not dramatic over the short run but it is over time. If \$100 is left in an account earning 5% interest, compounded annually, for 20 years instead of four years, the difference between the compound growth and noncompound growth is a little more interesting. After 20 years, the compound amount is \$265.33 compared to \$200 for simple interest (noncompound growth). A graph of the growth of each type over 40 years is given in Figure 9.1. The line is the growth for simple (noncompounded) interest, and the curve is the growth with compound interest.

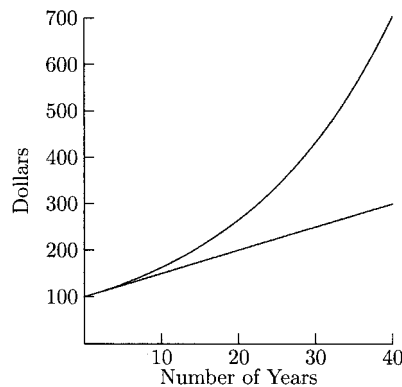

Fig. 9.1.

We can use a formula to compute the value of an account earning compounded interest. If  $P$  dollars is invested for  $t$  years, earning  $r$  interest rate, then it will grow to  $A$  dollars, where  $A = P(1 + r)^t$ .

## EXAMPLES

Find the compound amount.

- \$5000, after three years, earning 6% interest, compounded annually  
We will use the formula  $A = P(1 + r)^t$ .  $P = 5000$ ,  $r = 0.06$ , and  $t = 3$ .  
We want to know  $A$ , the compound amount.

$$\begin{aligned} A &= 5000(1 + 0.06)^3 = 5000(1.06)^3 = 5000(1.191016) \\ &= 5955.08 \end{aligned}$$

The compound amount is \$5955.08.

- \$10,000 after eight years,  $7\frac{1}{4}\%$  interest, compounded annually

$$A = 10,000(1 + 0.0725)^8 = 10,000(1.0725)^8 \approx 10,000(1.7505656) \\ \approx 17,505.66$$

The compound amount is \$17,505.66

Many investments pay more often than once a year, some paying interest daily. Instead of using the annual interest rate, we need to use the interest rate per period, and instead of using the number of years, we need to use the number of periods. If there are  $n$  compounding periods per year, then the interest rate per period is  $\frac{r}{n}$  and the total number of periods is  $nt$ . The compound amount formula becomes

$$A = P \left(1 + \frac{r}{n}\right)^{nt}.$$

## EXAMPLES

Find the compound amount.

- \$5000, after three years, earning 6% annual interest

(a) compounded semiannually

(b) compounded monthly

For (a), interest compounded semiannually means that it is compounded twice each year, so  $n = 2$ .

$$A = 5000 \left(1 + \frac{0.06}{2}\right)^{2(3)} = 5000(1.03)^6 \approx 5000(1.194052) \approx 5970.26$$

The compound amount is \$5970.26.

For (b), interest compounded monthly means that it is compounded 12 times each year, so  $n = 12$ .

$$A = 5000 \left(1 + \frac{0.06}{12}\right)^{12(3)} = 5000(1.005)^{36} \approx 5000(1.19668) \approx 5983.40$$

The compound amount is \$5983.40.

- \$10,000, after eight years, earning  $7\frac{1}{4}\%$  annual interest, compounded weekly  
Interest that is paid weekly is paid 52 times each year, so  $n = 52$ .

$$A = 10,000 \left(1 + \frac{0.0725}{52}\right)^{52(8)} \approx 10,000(1.001394231)^{416}$$

$$\approx 10,000(1.785317) \approx 17,853.17$$

The compound amount is \$17,853.17.



The more often interest is compounded per year, the more interest is earned. \$1000 earning 8% annual interest, compounded annually, is worth \$1080 after one year. If interest is compounded quarterly, it is worth \$1082.43 after one year. And if interest is compounded daily, it is worth \$1083.28 after one year. What if interest is compounded each hour? Each second? It turns out that the most this investment could be worth (at 8% interest) is \$1083.29, when interest is compounded each and every instant of time. Each instant of time, a tiny amount of interest is earned. This is called *continuous* compounding. The formula for the compound amount for interest compounded continuously is  $A = Pe^{rt}$ , where  $A$ ,  $P$ ,  $r$ , and  $t$  are the same quantities as before. The letter  $e$  stands for a constant called Euler's number. It is approximately 2.718281828. You probably have an  $e$  or  $e^x$  key on your calculator. Although  $e$  is irrational, it can be approximated by numbers of the form

$$\left(1 + \frac{1}{m}\right)^m,$$

where  $m$  is a large rational number. The larger  $m$  is, the better the approximation for  $e$ . If we make the substitution  $m = \frac{n}{r}$  and use some algebra, we can see how  $\left(1 + \frac{r}{n}\right)^{nt}$  is very close to  $e^{rt}$ , for large values of  $n$ . If interest is compounded every minute,  $n$  would be 525,600, a rather large number!

### EXAMPLE

- Find the compound amount of \$5000 after eight years, earning 12% annual interest, compounded continuously.

$$A = 5000e^{0.12(8)} = 5000e^{0.96} \approx 5000(2.611696) \approx 13,058.48$$

The compound amount is \$13,058.48.

The compound growth formula for continuously compounded interest is used for other growth and decay problems. The general exponential growth model is  $n(t) = n_0e^{rt}$ , where  $n(t)$  replaces  $A$  and  $n_0$  replaces  $P$ . Their meanings are the same— $n(t)$  is still the compound growth, and  $n_0$  is still the beginning amount. The variable  $t$  represents time in this formula; although, time will not always be measured in years. The growth rate and  $t$  need to have the same unit of measure. If the growth rate is in days, then  $t$  needs to be in days. If the growth rate is in hours, then  $t$  needs to be in hours, and so on. If the “population” is getting smaller, then the formula is  $n(t) = n_0e^{-rt}$ .

## EXAMPLES

- The population of a city is estimated to be growing at the rate of 10% per year. In 2000, its population was 160,000. Estimate its population in the year 2005.

The year 2000 corresponds to  $t = 0$ , so the year 2005 corresponds to  $t = 5$ ;  $n_0$ , the population in year  $t = 0$ , is 160,000. The population is growing at the rate of 10% per year, so  $r = 0.10$ . The formula  $n(t) = n_0e^{rt}$  becomes  $n(t) = 160,000e^{0.10t}$ . We want to find  $n(t)$  for  $t = 5$ .

$$n(5) = 160,000e^{0.10(5)} \approx 263,795$$

The city's population is expected to be 264,000 in the year 2005 (estimates and projections are normally rounded off).

- A county is losing population at the rate of 0.7% per year. If the population in 2001 is 1,000,000, what is it expected to be in the year 2008?

$n_0 = 1,000,000$ ,  $t = 0$  is the year 2001,  $t = 7$  is the year 2008, and  $r = 0.007$ . Because the county is losing population, we will use the decay model:  $n(t) = n_0e^{-rt}$ . The model for this county's population is  $n(t) = 1,000,000e^{-.007t}$ . We want to find  $n(t)$  for  $t = 7$ .

$$n(7) = 1,000,000e^{-.007(7)} \approx 952,181$$

The population is expected to be 952,000 in the year 2008.

- In an experiment, a culture of bacteria grew at the rate of 35% per hour. If 1000 bacteria were present at 10:00, how many were present at 10:45?

$$n_0 = 1000, r = 0.35, t \text{ is the number of hours after 10:00}$$

The growth model becomes  $n(t) = 1000e^{0.35t}$ . We want to find  $n(t)$  for 45 minutes, or  $t = 0.75$  hours.

$$n(0.75) = 1000e^{0.35(0.75)} = 1000e^{0.2625} \approx 1300$$

At 10:45, there were approximately 1300 bacteria present in the culture.

## Present Value

Suppose a couple wants to give their newborn grandson a gift of \$50,000 on his 20th birthday. They can earn  $7\frac{1}{2}\%$  interest, compounded annually. How much should they deposit now so that it grows to \$50,000 in 20 years? To answer this question,

we will use the formula  $A = P(1 + r)^t$ , where we know that  $A = 50,000$  but are looking for  $P$ .

$$\begin{aligned} 50,000 &= P(1 + 0.075)^{20} \\ &= P(1.075)^{20} \\ \frac{50,000}{(1.075)^{20}} &= P \end{aligned}$$

The couple should deposit \$11,770.66 now so that the investment grows to \$50,000 in 20 years.

We say that \$11,770.66 is the *present value* of \$50,000 due in 20 years, earning  $7\frac{1}{2}\%$  interest, compounded annually. The present value formula is  $P = A(1 + r)^{-t}$ , for interest compounded annually, and  $P = A(1 + \frac{r}{n})^{-nt}$ , for interest compounded  $n$  times per year.

### EXAMPLE

- Find the present value of \$20,000 due in  $8\frac{1}{2}$  years, earning 6% annual interest, compounded monthly.

$$P = 20,000 \left(1 + \frac{0.06}{12}\right)^{-12(8.5)} = 20,000(1.005)^{-102} \approx 12,025.18$$

The present value is \$12,025.18.

### PRACTICE

For Problems 1–7 find the compound amount.

1. \$800, after ten years,  $6\frac{1}{2}\%$  interest, compounded annually
2. \$1200 after six years,  $9\frac{1}{2}\%$  interest, compounded annually
3. A 20-year-old college student opens a retirement account with \$2000. If her account pays  $8\frac{1}{4}\%$  interest, compounded annually, how much will be in the account when she reaches age 65?

4. \$800, after ten years, earning  $6\frac{1}{4}\%$  annual interest
  - (a) compounded quarterly
  - (b) compounded weekly
5. \$9000, after five years, earning  $6\frac{3}{4}\%$  annual interest, compounded daily (assume 365 days per year).
6. \$800, after 10 years, earning  $6\frac{1}{2}\%$  annual interest, compounded continuously.
7. \$9000, after 5 years, earning  $6\frac{3}{4}\%$  annual interest, compounded continuously.
8. The population of a city in the year 2002 is 2,000,000 and is expected to grow 1.5% per year. Estimate the city's population for the year 2012.
9. A construction company estimates that a piece of equipment is worth \$150,000 when new. If it loses value continuously at the annual rate of 10%, what would its value be in 10 years?
10. Under certain conditions a culture of bacteria grow at the rate of about 200% per hour. If 8000 bacteria are present in a dish, how many will be in the dish after 30 minutes?
11. Find the present value of \$9000 due in five years, earning 7% annual interest, compounded annually.
12. Find the present value of \$50,000 due in 10 years, earning 4% annual interest, compounded quarterly.
13. Find the present value of \$125,000 due in  $4\frac{1}{2}$  years, earning  $6\frac{1}{2}\%$  annual interest, compounded weekly.

### SOLUTIONS

1.  $A = 800(1 + 0.065)^{10} = 800(1.065)^{10} \approx 800(1.877137) \approx 1501.71$   
The compound amount is \$1501.71.
2.  $A = 1200(1 + 0.095)^6 = 1200(1.095)^6 \approx 1200(1.72379) \approx 2068.55$   
The compound amount is \$2068.55.
3.  $A = 2000(1 + 0.0825)^{45} = 2000(1.0825)^{45} \approx 2000(35.420585) \approx 70,841.17$   
The account will be worth \$70,841.17.

4. (a)  $n = 4$

$$A = 800 \left( 1 + \frac{0.0625}{4} \right)^{4(10)} = 800(1.015625)^{40} \approx 800(1.85924) \\ \approx 1487.39$$

The compound amount is \$1487.39.

(b)  $n = 52$

$$A = 800 \left( 1 + \frac{0.0625}{52} \right)^{52(10)} = 800(1.00120192)^{520} \\ \approx 800(1.86754) \approx 1494.04$$

The compound amount is \$1494.04.

5.  $n = 365$

$$A = 9000 \left( 1 + \frac{0.0675}{365} \right)^{365(5)} \approx 9000(1.000184932)^{1825} \\ \approx 9000(1.4013959) \approx 12,612.56$$

The compound amount is \$12,612.56.

6.  $A = 800e^{0.065(10)} = 800e^{0.65} \approx 800(1.915540829) \approx 1532.43$

The compound amount is \$1532.43.

7.  $A = 9000e^{0.0675(5)} = 9000e^{0.3375} \approx 9000(1.401439608) \approx 12,612.96$

The compound amount is \$12,612.96.

8.  $n_0 = 2,000,000$ ,  $r = 0.015$  The growth formula is  $n(t) = 2,000,000e^{0.015t}$  and we want to find  $n(t)$  when  $t = 10$ .

$$n(10) = 2,000,000e^{0.015(10)} \approx 2,323,668$$

The population in the year 2012 is expected to be about 2.3 million.

9.  $n_0 = 150,000$ ,  $r = 0.10$  We will use the decay formula because value is being lost. The formula is  $n(t) = 150,000e^{-0.10t}$ . We want to find  $n(t)$  when  $t = 10$ .

$$n(10) = 150,000e^{-0.10(10)} \approx 55,181.92$$

The equipment will be worth about \$55,000 after 10 years.

10.  $n_0 = 8000$ ,  $r = 2$  The growth formula is  $n(t) = 8000e^{2t}$ . We want to find  $n(t)$  when  $t = 0.5$ .

$$n(0.5) = 8000e^{2(0.5)} \approx 21,746$$

About 21,700 bacteria will be present after 30 minutes.

11.  $P = 9000(1.07)^{-5} \approx 6416.88$

The present value is \$6416.88.

12.  $P = 50,000 \left(1 + \frac{0.04}{4}\right)^{-4(10)} = 50,000(1.01)^{-40} \approx 33,582.66$

The present value is \$33,582.66.

13.  $P = 125,000 \left(1 + \frac{0.065}{52}\right)^{-52(4.5)} = 125,000(1.00125)^{-234} \approx 93,316.45$

The present value is \$93,316.45.

## Graphs of Exponential Functions

A basic exponential function is of the form  $f(x) = a^x$ , where  $a$  is any positive number except 1. The graph of  $f(x) = a^x$  comes in two shapes depending whether  $0 < a < 1$  ( $a$  is positive but smaller than 1) or  $a > 1$ . Figure 9.2 is the graph of  $f(x) = (\frac{1}{2})^x$  and Figure 9.3 is the graph of  $f(x) = 2^x$ .

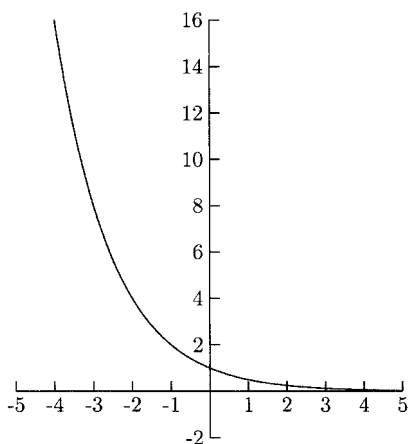

Fig. 9.2.

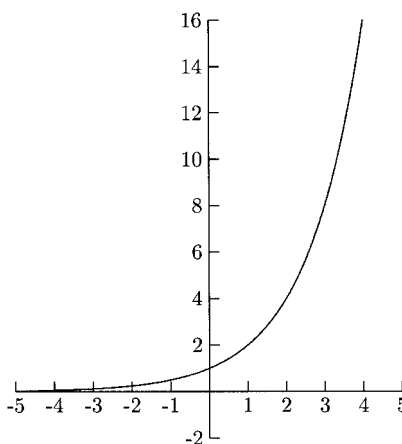

Fig. 9.3.

Sketch the graph of  $f(x) = a^x$  by plotting points for  $x = -3$ ,  $x = -2$ ,  $x = -1$ ,  $x = 0$ ,  $x = 1$ ,  $x = 2$ , and  $x = 3$ . If  $a$  is too large or too small, points for  $x = -3$

and  $x = 3$  might be too awkward to graph because their  $y$ -values are too large or too close to 0. Before we begin sketching graphs, we will review the following exponent properties.

$$a^{-n} = \frac{1}{a^n} \quad \left(\frac{1}{a}\right)^{-n} = a^n$$

## EXAMPLES

Sketch the graphs.

- $f(x) = 2.5^x$

We will begin with  $x = -3, -2, -1, 0, 1, 2,$  and  $3$  in a table of values.

**Table 9.1**

$x$	$f(x)$
-3	0.064 ( $2.5^{-3} = \frac{1}{2.5^3}$ )
-2	0.16 ( $2.5^{-2} = \frac{1}{2.5^2}$ )
-1	0.40 ( $2.5^{-1} = \frac{1}{2.5}$ )
0	1
1	2.5
2	6.25
3	15.625

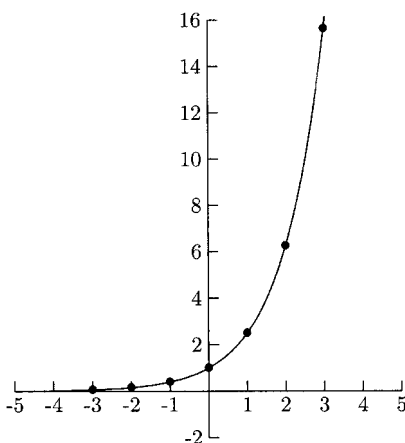
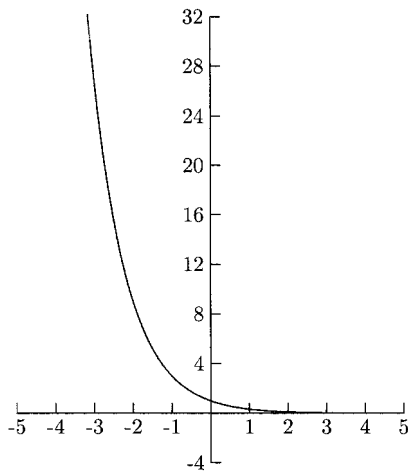

**Fig. 9.4.**

- $g(x) = \left(\frac{1}{3}\right)^x$

**Table 9.2**

$x$	$f(x)$
-3	$27 \left(\left(\frac{1}{3}\right)^{-3} = 3^3\right)$
-2	$9 \left(\left(\frac{1}{3}\right)^{-2} = 3^2\right)$
-1	$3 \left(\left(\frac{1}{3}\right)^{-1} = 3^1\right)$
0	1
1	0.33
2	0.11
3	0.037



**Fig. 9.5.**

## PRACTICE

Sketch the graphs.

1.  $f(x) = \left(\frac{3}{2}\right)^x$
2.  $g(x) = \left(\frac{2}{3}\right)^x$
3.  $h(x) = e^x$  (Use the  $e$  or  $e^x$  key on your calculator.)



SOLUTIONS

1.

Table 9.3

$x$	$f(x)$
-3	0.30 ( $(\frac{2}{3})^{-3} = (\frac{3}{2})^3 = \frac{8}{27}$ )
-2	0.44 ( $(\frac{2}{3})^{-2} = (\frac{3}{2})^2 = \frac{4}{9}$ )
-1	0.67 ( $(\frac{2}{3})^{-1} = \frac{3}{2}$ )
0	1
1	1.5
2	2.25
3	3.375

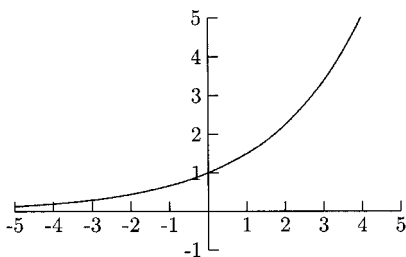

Fig. 9.6.

2.

Table 9.4

$x$	$f(x)$
-3	3.375 ( $(\frac{2}{3})^{-3} = (\frac{3}{2})^3$ )
-2	2.25 ( $(\frac{2}{3})^{-2} = (\frac{3}{2})^2$ )
-1	1.5 ( $(\frac{2}{3})^{-1} = \frac{3}{2}$ )
0	1
1	0.67
2	0.44
3	0.30

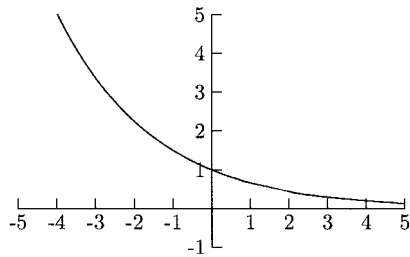

Fig. 9.7.

3.

Table 9.5

$x$	$f(x)$
-3	0.05
-2	0.14
-1	0.37
0	1
1	2.72
2	7.39
3	20.09

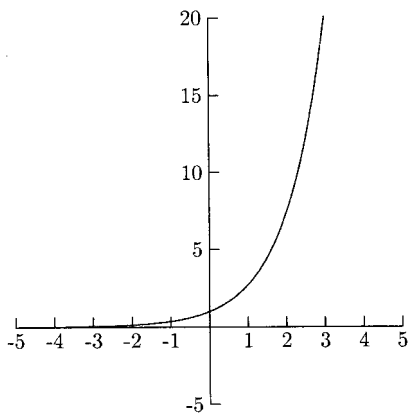

Fig. 9.8.

Transformations of the graphs of exponential functions behave in the same way as transformations of other functions.

## EXAMPLES

- The graph of  $f(x) = -2^x$  is the graph of  $y = 2^x$  reflected about the  $x$ -axis (flipped upside down).
- The graph of  $g(x) = 2^{-x}$  is the graph of  $y = 2^x$  reflected about the  $y$ -axis (flipped sideways).
- The graph of  $h(x) = 2^{x+1}$  is the graph of  $y = 2^x$  shifted to the left 1 unit.
- The graph of  $f(x) = -3 + 2^x$  is the graph of  $y = 2^x$  shifted down 3 units.

## Logarithms

A common question for investors is, “How long will it take for my investment to double?” If \$1000 is invested so that it earns 8% interest, compounded annually, how long will it take to grow to \$2000? To answer the question using the compound growth formula, we need to solve for  $t$  in the equation  $2000 = 1000(1.08)^t$ . We will divide both sides of the equation by 1000 to get  $2 = (1.08)^t$ . Now what? It does not make sense to “take the  $t^{\text{th}}$  root” of both sides. We need to use logarithms. In mathematical terms, the logarithm and exponent functions are inverses. Logarithms (or *logs*) are very useful in solving many science and business problems.

The logarithmic equation  $\log_a x = y$  is another way of writing the exponential equation  $a^y = x$ . Verbally, we say, “log base  $a$  of  $x$  is (or equals)  $y$ .” For “ $\log_a x$ , we say,” (the) log base  $a$  of  $x$ .

## EXAMPLES

Rewrite the logarithmic equation as an exponential equation.

- $\log_3 9 = 2$

The base of the logarithm is the base of the exponent, so 3 will be raised to a power. The number that is equal to the log is the power, so the power on 3 is 2.

$$\log_3 9 = 2 \text{ rewritten as an exponent is } 3^2 = 9$$

- $\log_2 \frac{1}{8} = -3$

The base is 2 and the power is  $-3$ .

$$2^{-3} = \frac{1}{8}$$

- $\log_9 3 = \frac{1}{2}$

The base is 9 and the power is  $\frac{1}{2}$ .

$$9^{\frac{1}{2}} = 3$$

Now we will work in the other direction, rewriting exponential equations as logarithmic equations. The equation  $4^3 = 64$  written as a logarithmic equation is  $\log_4 64 = 3$ .

### EXAMPLES

- $3^4 = 81$

The base of the logarithm is 3, and we are taking the log of 81. The equation rewritten as a logarithmic equation is  $\log_3 81 = 4$

- $a^3 = 4$

The base is  $a$ , and we are taking the log of 4. The equation rewritten as a logarithmic equation is  $\log_a 4 = 3$ .

- $8^{2/3} = 4$

The base is 8, and we are taking the log of 4. The equation rewritten as a logarithmic equation is  $\log_8 4 = \frac{2}{3}$ .

### PRACTICE

For Problems 1–5, rewrite the logarithmic equations as exponential equations. For Problems 6–12 rewrite the exponential equations as logarithmic equations.

1.  $\log_4 16 = 2$

2.  $\log_{100} 10 = \frac{1}{2}$

3.  $\log_e 2 = 0.6931$

4.  $\log_{(x+1)} 9 = 2$

5.  $\log_7 \frac{1}{49} = -2$

6.  $5^2 = 25$

7.  $4^0 = 1$

8.  $7^{-1} = \frac{1}{7}$

9.  $125^{1/3} = 5$
10.  $10^{-4} = 0.0001$
11.  $e^{1/2} = 1.6487$
12.  $8^x = 5$

## SOLUTIONS

1.  $\log_4 16 = 2$  rewritten as an exponential equation is  $4^2 = 16$
2.  $\log_{100} 10 = \frac{1}{2}$  rewritten as an exponential equation is  $100^{1/2} = 10$
3.  $\log_e 2 = 0.6931$  rewritten as an exponential equation is  $e^{0.6931} = 2$
4.  $\log_{(x+1)} 9 = 2$  rewritten as an exponential equation is  $(x + 1)^2 = 9$
5.  $\log_7 \frac{1}{49} = -2$  rewritten as an exponential equation is  $7^{-2} = \frac{1}{49}$
6.  $5^2 = 25$  rewritten as a logarithmic equation is  $\log_5 25 = 2$
7.  $4^0 = 1$  rewritten as a logarithmic equation is  $\log_4 1 = 0$
8.  $7^{-1} = \frac{1}{7}$  rewritten as a logarithmic equation is  $\log_7 \frac{1}{7} = -1$
9.  $125^{1/3} = 5$  rewritten as a logarithmic equation is  $\log_{125} 5 = \frac{1}{3}$
10.  $10^{-4} = 0.0001$  rewritten as a logarithmic equation is  $\log_{10} 0.0001 = -4$
11.  $e^{1/2} = 1.6487$  rewritten as a logarithmic equation is  $\log_e 1.6487 = \frac{1}{2}$
12.  $8^x = 5$  rewritten as a logarithmic equation is  $\log_8 5 = x$

The first two logarithm properties we will learn are the cancelation properties. They come directly from rewriting one form of an equation in the other form.

$$\log_a a^x = x \text{ and } a^{\log_a x} = x$$

When the bases of the exponent and logarithm are the same, they cancel. Let us see why these properties are true. What would the expression  $\log_a a^x$  be? We will rewrite the equation “ $\log_a a^x = ?$ ” as an exponential equation:  $a^? = a^x$ . Now we can see that “?” is  $x$ . This is why  $\log_a a^x = x$ . What would  $a^{\log_a x}$  be? We will rewrite “ $a^{\log_a x} = ?$ ” as a logarithmic equation:  $\log_a ? = \log_a x$ , so “?” is  $x$ , and  $a^{\log_a x} = x$ .

**EXAMPLES**

- $5^{\log_5 2}$

The bases of the logarithm and exponent are both 5, so  $5^{\log_5 2}$  simplifies to 2.

$$10^{\log_{10} 8} = 8 \quad 4^{\log_4 x} = x \quad e^{\log_e 6} = 6$$

$$29^{\log_{29} 1} = 1 \quad \log_m m^r = r \quad \log_7 7^{ab} = ab$$

Sometimes we need to use exponent properties before using the property  $\log_a a^x = x$ .

$$\sqrt[n]{a^m} = a^{\frac{m}{n}} \text{ and } \frac{1}{a^m} = a^{-m}$$

**EXAMPLES**

- $\log_9 3 = \log_9 \sqrt{9} = \log_9 9^{1/2} = \frac{1}{2}$
- $\log_7 \frac{1}{49} = \log_7 \frac{1}{7^2} = \log_7 7^{-2} = -2$
- $\log_{10} \sqrt[4]{10} = \log_{10} 10^{1/4} = \frac{1}{4}$
- $\log_{10} \sqrt[5]{100} = \log_{10} \sqrt[5]{10^2} = \log_{10} 10^{2/5} = \frac{2}{5}$

Two types of logarithms occur frequently enough to have their own notation. They are  $\log_e$  and  $\log_{10}$ . The notation for  $\log_e$  is “ln” (pronounced “ell-in”) and is called the *natural log*. The notation for  $\log_{10}$  is “log” (no base is written) and is called the *common log*. The cancel properties for these special logarithms are

$$\ln e^x = x \quad e^{\ln x} = x \quad \text{and} \quad \log 10^x = x \quad 10^{\log x} = x.$$

**EXAMPLES**

- $e^4 = x - 1$  rewritten as a log equation is  $\ln(x - 1) = 4$
- $10^x = 6$  rewritten as a log equation is  $\log 6 = x$
- $\ln 2x = 25$  rewritten as an exponent equation is  $e^{25} = 2x$
- $\log(2x - 9) = 4$  rewritten as an exponent equation is  $10^4 = 2x - 9$ 
  - $\ln e^{15} = 15$
  - $e^{\ln 14} = 14$
  - $\ln e^{-4} = -4$
  - $10^{\log 5} = 5$
  - $\log 10^{1/2} = \frac{1}{2}$
  - $\log 10^{-4} = -4$

**PRACTICE**

1. Rewrite as a logarithm:  $e^{3x} = 4$
2. Rewrite as a logarithm:  $10^{x-1} = 15$
3. Rewrite as an exponent:  $\ln 6 = x + 1$
4. Rewrite as an exponent:  $\log 5x = 3$

Use logarithm properties to simplify the expression.

5.  $9^{\log_9 3}$
6.  $10^{\log_{10} 14}$
7.  $5^{\log_5 x}$
8.  $\log_{15} 15^2$
9.  $\log_{10} 10^{-8}$
10.  $\log_e e^x$
11.  $\log_7 \sqrt{7}$
12.  $\log_5 \frac{1}{5}$
13.  $\log_3 \frac{1}{\sqrt{3}}$
14.  $\log_4 \frac{1}{16}$
15.  $\log_{25} \frac{1}{5}$
16.  $\log_8 \frac{1}{2}$
17.  $\log_{10} \sqrt{1000}$
18.  $\ln e^5$
19.  $\log 10^{\sqrt{x}}$
20.  $10^{\log 9}$
21.  $e^{\ln 6}$
22.  $\log 10^{3x-1}$
23.  $\ln e^{x+1}$

**SOLUTIONS**

1.  $\ln 4 = 3x$
2.  $\log 15 = x - 1$

3.  $e^{x+1} = 6$

4.  $10^3 = 5x$

5.  $9^{\log_9 3} = 3$

6.  $10^{\log_{10} 14} = 14$

7.  $5^{\log_5 x} = x$

8.  $\log_{15} 15^2 = 2$

9.  $\log_{10} 10^{-8} = -8$

10.  $\log_e e^x = x$

11.  $\log_7 \sqrt{7} = \log_7 7^{1/2} = \frac{1}{2}$

12.  $\log_5 \frac{1}{5} = \log_5 5^{-1} = -1$

13.  $\log_3 \frac{1}{\sqrt{3}} = \log_3 \frac{1}{3^{1/2}} = \log_3 3^{-1/2} = -\frac{1}{2}$

14.  $\log_4 \frac{1}{16} = \log_4 \frac{1}{4^2} = \log_4 4^{-2} = -2$

15.  $\log_{25} \frac{1}{5} = \log_{25} \frac{1}{\sqrt{25}} = \log_{25} \frac{1}{25^{1/2}} = \log_{25} 25^{-1/2} = -\frac{1}{2}$

16.  $2 = \sqrt[3]{8}$

$$\log_8 \frac{1}{2} = \log_8 \frac{1}{\sqrt[3]{8}} = \log_8 \frac{1}{8^{1/3}} = \log_8 8^{-1/3} = -\frac{1}{3}$$

17.  $1000 = 10^3$ , so  $\log_{10} \sqrt{1000} = \log_{10} \sqrt{10^3} = \log_{10} 10^{3/2} = 3/2$

18.  $\ln e^5 = 5$

19.  $\log 10^{\sqrt{x}} = \sqrt{x}$

20.  $10^{\log 9} = 9$

21.  $e^{\ln 6} = 6$

22.  $\log 10^{3x-1} = 3x - 1$

23.  $\ln e^{x+1} = x + 1$



## Exponent and Logarithm Equations (Part I)

Equations with exponents and logarithms come in many forms. Sometimes more than one strategy will work to solve them. We will first solve equations of the form “log = number” and “log = log.” We will solve an equation of the form “log = number” by rewriting the equation as an exponential equation.

### EXAMPLES

Solve the equation for  $x$ .

- $\log_3(x + 1) = 4$

Rewrite the equation as an exponential equation.

$$\log_3(x + 1) = 4$$

$$3^4 = x + 1$$

$$81 = x + 1$$

$$80 = x$$

- $\log_2(3x - 4) = 5$

$$2^5 = 3x - 4$$

$$32 = 3x - 4$$

$$12 = x$$

The logarithms cancel for equations in the form “log = log” as long as the bases are the same. For example, the solution to the equation  $\log_8 x = \log_8 10$  is  $x = 10$ . The cancelation law  $a^{\log_a x} = x$  makes this work.

$$\log_8 x = \log_8 10$$

$$8^{\log_8 x} = 8^{\log_8 10}$$

$$x = 10 \quad (\text{By the cancelation law})$$

## EXAMPLES

Solve for  $x$ .

- $\log_6(x + 1) = \log_6 2x$

$$\log_6(x + 1) = \log_6 2x$$

$$x + 1 = 2x \quad \text{The logs cancel.}$$

$$1 = x$$

- $\log 4 = \log(x - 1)$

$$\log 4 = \log(x - 1)$$

$$4 = x - 1 \quad \text{The logs cancel.}$$

$$5 = x$$

## PRACTICE

Solve for  $x$ .

1.  $\log_7(2x + 1) = 2$

2.  $\log_4(x + 6) = 2$

3.  $\log 5x = 1$

4.  $\log_2(8x - 1) = 4$

5.  $\log_3(4x - 1) = \log_3 2$

6.  $\log_2(3 - x) = \log_2 17$

7.  $\ln 15x = \ln(x + 4)$

8.  $\log \frac{x}{x-1} = \log \frac{1}{2}$

## SOLUTIONS

1.  $\log_7(2x + 1) = 2$

$$7^2 = 2x + 1$$

$$24 = x$$

$$2. \log_4(x + 6) = 2$$

$$4^2 = x + 6$$

$$10 = x$$

$$3. \log 5x = 1$$

$$10^1 = 5x$$

$$2 = x$$

$$4. \log_2(8x - 1) = 4$$

$$2^4 = 8x - 1$$

$$\frac{17}{8} = x$$

$$5. \log_3(4x - 1) = \log_3 2$$

$$4x - 1 = 2$$

$$x = \frac{3}{4}$$

$$6. \log_2(3 - x) = \log_2 17$$

$$3 - x = 17$$

$$x = -14$$

$$7. \ln 15x = \ln(x + 4)$$

$$15x = x + 4$$

$$x = \frac{4}{14} = \frac{2}{7}$$

$$8. \log \frac{x}{x-1} = \log \frac{1}{2}$$

$$\frac{x}{x-1} = \frac{1}{2} \quad \text{Cross-multiply.}$$

$$2x = x - 1$$

$$x = -1$$

We need to use calculators to find approximate solutions for exponential equations whose base is  $e$  or 10. We will rewrite the exponential equation as a

logarithmic equation, solve for  $x$ , and then use a calculator to get an approximate solution.

## EXAMPLES

Solve for  $x$ . Give solutions accurate to four decimal places.

- $e^{2x} = 3$

$$e^{2x} = 3 \quad \text{Rewrite as a logarithmic equation.}$$

$$2x = \ln 3$$

$$x = \frac{\ln 3}{2}$$

$$x \approx \frac{1.0986}{2} \approx 0.5493$$

- $10^{x+1} = 9$

$$10^{x+1} = 9 \quad \text{Rewrite as a logarithmic equation.}$$

$$x + 1 = \log 9$$

$$x = -1 + \log 9$$

$$x \approx -1 + 0.9542 \approx -0.0458$$

- $2500 = 1000e^{x-4}$

$$2500 = 1000e^{x-4} \quad \text{Divide both sides by 1000 before rewriting the equation.}$$

$$e^{x-4} = 2.5 \quad \text{Rewrite as a logarithmic equation.}$$

$$x - 4 = \ln 2.5$$

$$x = 4 + \ln 2.5 \approx 4 + 0.9163 \approx 4.9163$$

## PRACTICE

Solve for  $x$ . Give your solutions accurate to four decimal places.

1.  $10^{3x} = 7$

2.  $e^{2x+5} = 15$

3.  $5000 = 2500e^{4x}$
4.  $32 = 8 \cdot 10^{6x-4}$
5.  $200 = 400e^{-0.06x}$

## SOLUTIONS

1.  $10^{3x} = 7$   
 $3x = \log 7$   
 $x = \frac{\log 7}{3} \approx \frac{0.8451}{3} \approx 0.2817$
2.  $e^{2x+5} = 15$   
 $2x + 5 = \ln 15$   
 $2x = -5 + \ln 15$   
 $x = \frac{-5 + \ln 15}{2} \approx \frac{-5 + 2.7081}{2} \approx -1.1460$
3.  $5000 = 2500e^{4x}$   
 $\frac{5000}{2500} = e^{4x}$   
 $4x = \ln \left( \frac{5000}{2500} \right)$   
 $4x = \ln 2$   
 $x = \frac{\ln 2}{4} \approx \frac{0.6931}{4} \approx 0.1733$
4.  $32 = 8 \cdot 10^{6x-4}$       Divide both sides by 8.  
 $4 = 10^{6x-4}$   
 $6x - 4 = \log 4$   
 $6x = 4 + \log 4$   
 $x = \frac{4 + \log 4}{6} \approx \frac{4 + 0.6021}{6} \approx 0.767$
5.  $200 = 400e^{-0.06x}$   
 $\frac{1}{2} = e^{-0.06x}$

$$-0.06x = \ln\left(\frac{1}{2}\right)$$

$$x = \frac{\ln(\frac{1}{2})}{-0.06} \approx \frac{-0.69315}{-0.06} \approx 11.5525$$

The logarithm function  $f(x) = \log_a x$  is the inverse of  $g(x) = a^x$ . The graph of  $f(x)$  is the graph of  $g(x)$  with the  $x$ - and  $y$ -values reversed. To sketch the graph by hand, we will rewrite the logarithm function as an exponent equation and graph the exponent equation.

## EXAMPLES

Sketch the graph of the logarithmic functions.

- $y = \log_2 x$

Rewrite the equation in exponential form,  $x = 2^y$ , and let the exponent,  $y$ , be the numbers  $-3, -2, -1, 0, 1, 2,$  and  $3$ .

**Table 9.6**

$x$	$y$
$\frac{1}{8}$	$-3$
$\frac{1}{4}$	$-2$
$\frac{1}{2}$	$-1$
$1$	$0$
$2$	$1$
$4$	$2$
$8$	$3$

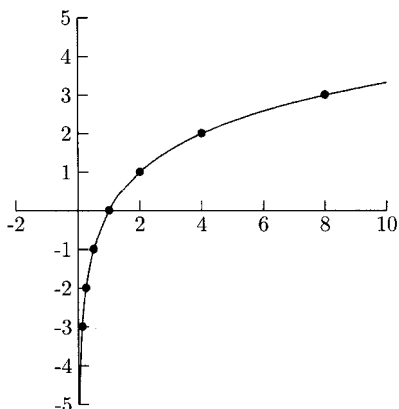

**Fig. 9.9.**

- $y = \ln x$

Rewritten as an exponent equation, this is  $x = e^y$ . Let  $y = -3, -2, -1, 0, 1, 2,$  and  $3$ .

**Table 9.7**

$x$	$y$
0.05	-3
0.14	-2
0.37	-1
1	0
2.72	1
7.39	2
20.09	3

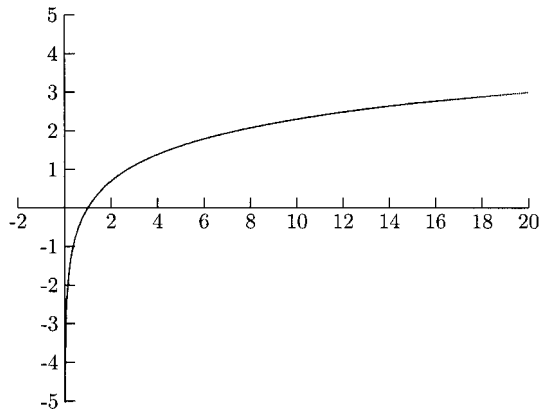

**Fig. 9.10.**

As you can see by these graphs, the domain of the function  $f(x) = \log_a x$  is all positive real numbers,  $(0, \infty)$ .

## PRACTICE

Sketch the graph of the logarithmic function.

1.  $y = \log_{1.5} x$
2.  $y = \log_3 x$

SOLUTIONS

1.

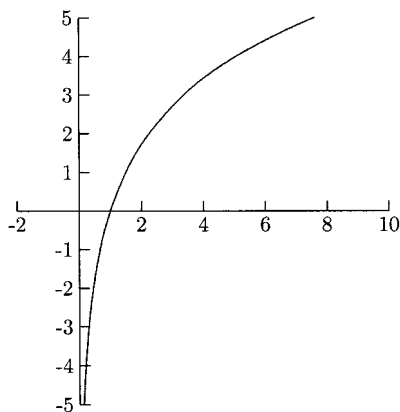

Fig. 9.11.

2.

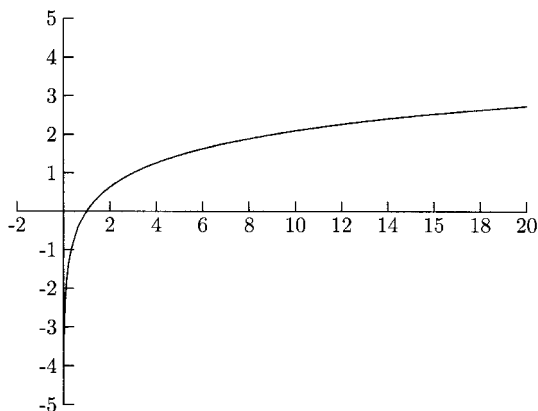

Fig. 9.12.

As long as  $a$  is larger than 1, all graphs for  $f(x) = \log_a x$  look pretty much the same. The larger  $a$  is, the flatter the graph is to the right of  $x = 1$ . Knowing this and knowing how to graph transformations, we have a good idea of the graphs of many logarithmic functions.

- The graph of  $f(x) = \log_2(x - 2)$  is the graph of  $y = \log_2 x$  shifted to the right 2 units.
- The graph of  $f(x) = -5 + \log_3 x$  is the graph of  $y = \log_3 x$  shifted down 5 units.



- $f(x) = \frac{1}{3} \log x$  is the graph of  $y = \log x$  flattened vertically by a factor of one-third.

The domain of  $f(x) = \log_a x$  is all positive numbers. This means that we cannot take the log of 0 or the log of a negative number. The reason is that  $a$  is a positive number. Raising a positive number to *any* power is always another positive number.

## EXAMPLES

Find the domain. Give your answers in interval notation.

- $f(x) = \log_5(2 - x)$

Because we are taking the log of  $2 - x$ ,  $2 - x$  needs to be positive.

$$2 - x > 0$$

$$-x > -2$$

$$x < 2$$

The domain is  $(-\infty, 2)$ .

- $f(x) = \log(x^2 - x - 2)$

$$x^2 - x - 2 > 0$$

$$(x - 2)(x + 1) > 0$$

Put  $x = 2$  and  $x = -1$  on the number line and test to see where  $(x - 2)(x + 1) > 0$  is true.

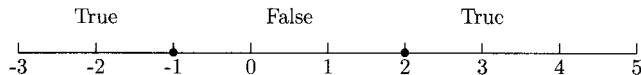

Fig. 9.13.

We want the “True” intervals, so the domain is  $(-\infty, -1) \cup (2, \infty)$ .

- $g(x) = \ln(x^2 + 1)$

Because  $x^2 + 1$  is always positive, the domain is all real numbers,  $(-\infty, \infty)$ .

## PRACTICE

Find the domain. Give your answers in interval notation.

1.  $f(x) = \ln(10 - 2x)$

2.  $h(x) = \log(x^2 - 4)$

3.  $f(x) = \log(x^2 + 4)$

### SOLUTIONS

1. Solve  $10 - 2x > 0$ . The domain is  $x < 5, (-\infty, 5)$ .

2. Solve  $x^2 - 4 > 0$

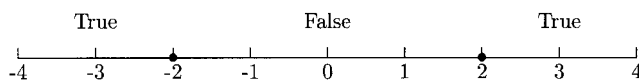

Fig. 9.14.

The domain is  $(-\infty, -2) \cup (2, \infty)$ .

3. Because  $x^2 + 4 > 0$  is always positive, the domain is all real numbers,  $(-\infty, \infty)$ .

### Exponent and Logarithmic Equations (Part II)

For some logarithmic equations, a solution might be extraneous solution. That is, such a solution is a solution to the rewritten equations but not to the original equations. Some solutions to the rewritten equations will cause logarithms of 0 or of negative numbers. We can check them in the original equation to see which solutions are true solutions.

### EXAMPLES

Solve for  $x$ .

- $\log_2(x^2 + 3x - 10) = 3$

We will rewrite this as an exponent equation:  $2^3 = x^2 + 3x - 10$  and solve for  $x$ .

$$x^2 + 3x - 10 = 8$$

$$x^2 + 3x - 18 = 0$$

$$(x + 6)(x - 3) = 0$$

The solutions are  $x = -6$  and  $x = 3$ . We will check them in the original equation.

$$\log_2((-6)^2 + 3(-6) - 10) = 3? \qquad \log_2(3^2 + 3(3) - 10) = 3?$$

$$\log_2 8 = 3 \text{ True} \qquad \log_2 8 = 3 \text{ True}$$

The solutions to the original equation are  $x = -6$  and  $x = 3$ .

- $\log_5(x^2 + 5x - 4) = \log_5(x + 1)$

The logs cancel leaving  $x^2 + 5x - 4 = x + 1$ .

$$x^2 + 5x - 4 = x + 1$$

$$x^2 + 4x - 5 = 0$$

$$(x + 5)(x - 1) = 0$$

The solutions are  $x = -5$  and  $x = 1$ . We cannot allow  $x = -5$  as a solution because  $\log_5(-5 + 1)$  is not defined. We need to check  $x = 1$ .

$$\log_5(1^2 + 5(1) - 4) = \log_5(1 + 1) \quad \text{is true}$$

The solution is  $x = 1$ .

## PRACTICE

Solve for  $x$ .

1.  $\ln(x^2 + x - 20) = \ln(3x + 4)$
2.  $\log_4(2x^2 - 3x + 59) = 3$

## SOLUTIONS

1.  $\ln(x^2 + x - 20) = \ln(3x + 4)$

$$x^2 + x - 20 = 3x + 4$$

$$x^2 - 2x - 24 = 0$$

$$(x - 6)(x + 4) = 0$$

The solutions are  $x = 6$  and  $x = -4$ . Because  $\ln[3(-4) + 4]$  is not defined, we only need to check  $x = 6$ .

$$\ln(6^2 + 6 - 20) = \ln[3(6) + 4] \quad \text{is true.}$$

The only solution is  $x = 6$ .

$$2. \log_4(2x^2 - 3x + 59) = 3$$

$$2x^2 - 3x + 59 = 4^3 \quad (4^3 = 64)$$

$$2x^2 - 3x - 5 = 0$$

$$(2x - 5)(x + 1) = 0$$

We need to check the solutions  $x = \frac{5}{2}$  and  $x = -1$ .

$$\log_4 \left[ 2 \left( \frac{5}{2} \right)^2 - 3 \left( \frac{5}{2} \right) + 59 \right] = 3? \quad \log_4 [2(-1)^2 - 3(-1) + 59] = 3?$$

$$\log_4 64 = 3 \text{ is true}$$

$$\log_4 64 = 3 \text{ is true}$$

The solutions are  $x = \frac{5}{2}$  and  $x = -1$ .

## Three More Important Logarithm Properties

The following three logarithm properties come directly from the exponent properties  $a^m \cdot a^n = a^{m+n}$ ,  $\frac{a^m}{a^n} = a^{m-n}$ , and  $a^{mn} = (a^m)^n$ .

$$1. \log_b mn = \log_b m + \log_b n$$

$$2. \log_b \frac{m}{n} = \log_b m - \log_b n$$

$$3. \log_b m^t = t \log_b m$$

We will see why Property 1 works. Let  $x = \log_b m$  and  $y = \log_b n$ . Rewriting these equations as exponential equations, we get  $b^x = m$  and  $b^y = n$ . Multiplying  $m$  and  $n$ , we have  $mn = b^x \cdot b^y = b^{x+y}$ . Rewriting the equation  $mn = b^{x+y}$  as a logarithmic equation, we get  $\log_b mn = x + y$ . Because  $x = \log_b m$  and  $y = \log_b n$ ,  $\log_b mn = x + y$  becomes  $\log_b mn = \log_b m + \log_b n$ .

## EXAMPLES

Use Property 1 to rewrite the logarithms.

- $\log_4 7x = \log_4 7 + \log_4 x$
- $\ln 15t = \ln 15 + \ln t$
- $\log_6 19t^2 = \log_6 19 + \log_6 t^2$
- $\log 100y^4 = \log 10^2 + \log y^4 = 2 + \log y^4$

- $\log_9 3 + \log_9 27 = \log_9 3(27) = \log_9 81 = 2$
- $\ln x + \ln \sqrt{y} = \ln x \sqrt{y}$

Use Property 2 to rewrite the logarithms.

- $\log \left( \frac{x}{4} \right) = \log x - \log 4$
- $\ln \left( \frac{5}{x} \right) = \ln 5 - \ln x$
- $\log_{15} 3 - \log_{15} 2 = \log_{15} \left( \frac{3}{2} \right)$
- $\ln 16 - \ln t = \ln \frac{16}{t}$
- $\log_4 \left( \frac{4}{3} \right) = \log_4 4 - \log_4 3 = 1 - \log 3$

The exponent property  $\sqrt[n]{a^m} = a^{m/n}$  allows us to apply the third logarithm property to roots as well as to powers. The third logarithm property is especially useful in science and business applications.

## EXAMPLES

Use Property 3 to rewrite the logarithms.

- $\log_4 3^x = x \log_4 3$
- $\frac{1}{3} \ln t = \ln t^{1/3}$
- $\log_6 \sqrt{2x} = \log_6 (2x)^{1/2} = \frac{1}{2} \log_6 2x$
- $\ln \sqrt[4]{t^3} = \ln t^{3/4} = \frac{3}{4} \ln t$
- $\log x^2 = 2 \log x$
- $-3 \log 8 = \log 8^{-3}$

## PRACTICE

Use Property 1 to rewrite the logarithms in Problems 1–6.

1.  $\ln 59t$
2.  $\log 0.10y$
3.  $\log_{30} 148x^2$

4.  $\log_6 3 + \log_6 12$

5.  $\log_5 9 + \log_5 10$

6.  $\log 5 + \log 20$

Use Property 2 to rewrite the logarithms in Problems 7–12.

7.  $\log_4 \frac{10}{9x}$

8.  $\log_2 \frac{7}{8}$

9.  $\ln \frac{t}{4}$

10.  $\log \frac{100}{x^2}$

11.  $\log_7 2 - \log_7 4$

12.  $\log_8 x - \log_8 3$

Use Property 3 to rewrite the logarithms in Problems 13–20.

13.  $\ln 5^x$

14.  $\log_{12} \sqrt{3}$

15.  $\log \sqrt{16x}$

16.  $\log_5 6^{-t}$

17.  $2 \log_8 3$

18.  $(x + 6) \log_4 3$

19.  $\log_{16} 10^{2x}$

20.  $-2 \log_4 5$

## SOLUTIONS

1.  $\ln 59t = \ln 59 + \ln t$

2.  $\log 0.10y = \log 0.10 + \log y = \log 10^{-1} + \log y = -1 + \log y$

3.  $\log_{30} 148x^2 = \log_{30} 148 + \log_{30} x^2$

4.  $\log_6 3 + \log_6 12 = \log_6(3 \cdot 12) = \log_6 36 = \log_6 6^2 = 2$

5.  $\log_5 9 + \log_5 10 = \log_5(9 \cdot 10) = \log_5 90$

6.  $\log 5 + \log 20 = \log(5 \cdot 20) = \log 100 = \log 10^2 = 2$

7.  $\log_4 \frac{10}{9x} = \log_4 10 - \log_4 9x$

8.  $\log_2 \frac{7}{8} = \log_2 7 - \log_2 8 = \log_2 7 - \log_2 2^3 = (\log_2 7) - 3$
9.  $\ln \frac{t}{4} = \ln t - \ln 4$
10.  $\log \frac{100}{x^2} = \log 100 - \log x^2 = \log 10^2 - \log x^2 = 2 - \log x^2$
11.  $\log_7 2 - \log_7 4 = \log_7 \frac{2}{4} = \log_7 \frac{1}{2}$
12.  $\log_8 x - \log_8 3 = \log_8 \frac{x}{3}$
13.  $\ln 5^x = x \ln 5$
14.  $\log_{12} \sqrt{3} = \log_{12} 3^{1/2} = \frac{1}{2} \log_{12} 3$
15.  $\log \sqrt{16x} = \log(16x)^{1/2} = \frac{1}{2} \log 16x$
16.  $\log_5 6^{-t} = -t \log_5 6$
17.  $2 \log_8 3 = \log_8 3^2 = \log_8 9$
18.  $(x + 6) \log_4 3 = \log_4 3^{x+6}$
19.  $\log_{16} 10^{2x} = 2x \log_{16} 10$
20.  $-2 \log_4 5 = \log_4 5^{-2} = \log_4 \frac{1}{5^2} = \log_4 \frac{1}{25}$

Sometimes we will need to use several logarithm properties to rewrite more complicated logarithms. The hardest part of this is to use the properties in the correct order. For example, which property should be used first on  $\log \frac{x}{y^3}$ ? Do we first use the third property or the second property? We will use the second property first. For the expression  $\log(\frac{x}{y})^3$ , we would use the third property first.

Going in the other direction, we need to use all three properties in the expression  $\log_2 9 - \log_2 x + 3 \log_2 y$ . We need to use the second property to combine the first two terms.

$$\log_2 9 - \log_2 x + 3 \log_2 y = \log_2 \frac{9}{x} + 3 \log_2 y$$

We cannot use the first property on  $\log_2 \frac{9}{x} + 3 \log_2 y$  until we have used the third property to move the 3.

$$\log_2 \frac{9}{x} + 3 \log_2 y = \log_2 \frac{9}{x} + \log_2 y^3 = \log_2 y^3 \frac{9}{x} = \log_2 \frac{9y^3}{x}$$

## EXAMPLES

Rewrite as a single logarithm.

- $\log_2 3x - 4 \log_2 y$

We need use the third property to move the 4, then we can use the second property.

$$\log_2 3x - 4 \log_2 y = \log_2 3x - \log_2 y^4 = \log_2 \frac{3x}{y^4}$$

- $3 \log 4x + 2 \log 3 - 2 \log y$

$$3 \log 4x + 2 \log 3 - 2 \log y = \log(4x)^3 + \log 3^2 - \log y^2 \quad \text{Property 3}$$

$$= \log 4^3 x^3 \cdot 3^2 - \log y^2 \quad \text{Property 1}$$

$$= \log 576x^3 - \log y^2 = \log \frac{576x^3}{y^2} \quad \text{Property 2}$$

- $t \ln 4 + \ln 5$

$$t \ln 4 + \ln 5 = \ln 4^t + \ln 5 = \ln(5 \cdot 4^t) \quad (\text{not } \ln 20^t)$$

Expand each logarithm.

- $\ln \frac{3\sqrt{x}}{y^2}$

$$\ln \frac{3\sqrt{x}}{y^2} = \ln 3(x^{1/2}) - \ln y^2 = \ln 3 + \ln x^{1/2} - \ln y^2 = \ln 3 + \frac{1}{2} \ln x - 2 \ln y$$

- $\log_7 \frac{4}{10xy^2}$

$$\log_7 \frac{4}{10xy^2} = \log_7 4 - \log_7 10xy^2 = \log_7 4 - (\log_7 10 + \log_7 x + \log_7 y^2)$$

$$= \log_7 4 - (\log_7 10 + \log_7 x + 2 \log_7 y) \text{ or}$$

$$\log_7 4 - \log_7 10 - \log_7 x - 2 \log_7 y$$

## PRACTICE

For Problems 1–5, rewrite each as a single logarithm.

1.  $2 \log x + 3 \log y$



2.  $\log_6 2x - 2 \log_6 3$
3.  $3 \ln t - \ln 4 + 2 \ln 5$
4.  $t \ln 6 + 2 \ln 5$
5.  $\frac{1}{2} \log x - 2 \log 2y + 3 \log z$

For Problems 6–10, expand each logarithm.

6.  $\log \frac{4x}{y}$
7.  $\ln \frac{6}{\sqrt{y}}$
8.  $\log_4 \frac{10x}{\sqrt[3]{z}}$
9.  $\ln \frac{\sqrt{4x}}{5y^2}$
10.  $\log \sqrt{\frac{2y^3}{x}}$

## SOLUTIONS

1.  $2 \log x + 3 \log y = \log x^2 + \log y^3 = \log x^2 y^3$
2.  $\log_6 2x - 2 \log_6 3 = \log_6 2x - \log_6 3^2$   
 $= \log_6 2x - \log_6 9 = \log_6 \frac{2x}{9}$
3.  $3 \ln t - \ln 4 + 2 \ln 5 = \ln t^3 - \ln 4 + \ln 5^2$   
 $= \ln \frac{t^3}{4} + \ln 25$   
 $= \ln 25 \frac{t^3}{4} = \ln \frac{25t^3}{4}$
4.  $t \ln 6 + 2 \ln 5 = \ln 6^t + \ln 5^2 = \ln[25(6^t)]$
5.  $\frac{1}{2} \log x - 2 \log 2y + 3 \log z = \log x^{1/2} - \log(2y)^2 + \log z^3$   
 $= \log x^{1/2} - \log 2^2 y^2 + \log z^3$   
 $= \log x^{1/2} - \log 4y^2 + \log z^3$

$$\begin{aligned}
 &= \log \frac{x^{1/2}}{4y^2} + \log z^3 = \log z^3 \frac{x^{1/2}}{4y^2} \\
 &= \log \frac{z^3 x^{1/2}}{4y^2} \text{ or } \log \frac{z^3 \sqrt{x}}{4y^2}
 \end{aligned}$$

$$6. \log \frac{4x}{y} = \log 4x - \log y = \log 4 + \log x - \log y$$

$$7. \ln \frac{6}{\sqrt{y}} = \ln 6 - \ln \sqrt{y} = \ln 6 - \ln y^{1/2} = \ln 6 - \frac{1}{2} \ln y$$

$$\begin{aligned}
 8. \log_4 \frac{10x}{\sqrt[3]{z}} &= \log_4 10x - \log_4 \sqrt[3]{z} = \log_4 10x - \log_4 z^{1/3} \\
 &= \log_4 10 + \log_4 x - \frac{1}{3} \log_4 z
 \end{aligned}$$

$$\begin{aligned}
 9. \ln \frac{\sqrt{4x}}{5y^2} &= \ln \sqrt{4x} - \ln 5y^2 = \ln(4x)^{1/2} - \ln 5y^2 \\
 &= \frac{1}{2} \ln 4x - (\ln 5 + \ln y^2) = \frac{1}{2}(\ln 4 + \ln x) - (\ln 5 + 2 \ln y) \\
 &\text{or } \frac{1}{2} \ln 4 + \frac{1}{2} \ln x - \ln 5 - 2 \ln y
 \end{aligned}$$

$$\begin{aligned}
 10. \log \sqrt{\frac{2y^3}{x}} &= \log \left( \frac{2y^3}{x} \right)^{1/2} = \frac{1}{2} \log \frac{2y^3}{x} \\
 &= \frac{1}{2}(\log 2y^3 - \log x) = \frac{1}{2}(\log 2 + \log y^3 - \log x) \\
 &= \frac{1}{2}(\log 2 + 3 \log y - \log x) \text{ or } \frac{1}{2} \log 2 + \frac{3}{2} \log y - \frac{1}{2} \log x
 \end{aligned}$$

## More Logarithm Equations

With these logarithm properties we can solve more logarithm equations. We will use these properties to rewrite equations either in the form “log = log” or “log = number.” When the equation is in the form “log = log,” the logs cancel. When the equation is in the form “log = number,” we will rewrite the equation as an exponential equation. Instead of checking solutions in the original equation, we only need to make sure that the original logarithms are defined for the solutions.

## EXAMPLES

- $\log_2(x - 5) + \log_2(x + 2) = 3$

We will use Property 1 to rewrite the equation in the form “log = number.”

$$\log_2(x - 5) + \log_2(x + 2) = 3$$

$$\log_2(x - 5)(x + 2) = 3$$

$$(x - 5)(x + 2) = 2^3$$

$$x^2 - 3x - 10 = 8$$

$$x^2 - 3x - 18 = 0$$

$$(x - 6)(x + 3) = 0$$

The solutions are  $x = 6$  and  $x = -3$ . Because  $\log_2(x + 2)$  is not defined for  $x = -3$ , the only solution is  $x = 6$ .

- $2 \log_5(x + 1) - \log_5(x - 3) = \log_5 25$

We will use Property 3 followed by Property 2 to rewrite the equation in the form “log = log.”

$$2 \log_5(x + 1) - \log_5(x - 3) = \log_5 25$$

$$\log_5(x + 1)^2 - \log_5(x - 3) = \log_5 25$$

$$\log_5 \frac{(x + 1)^2}{x - 3} = \log_5 25$$

$$\frac{(x + 1)^2}{x - 3} = 25$$

$$(x + 1)^2 = 25(x - 3)$$

$$(x + 1)(x + 1) = 25x - 75$$

$$x^2 + 2x + 1 = 25x - 75$$

$$x^2 - 23x + 76 = 0$$

$$(x - 4)(x - 19) = 0$$

Both  $\log_5(x + 1)$  and  $\log_5(x - 3)$  are defined for  $x = 4$  and  $x = 19$ . The solutions are  $x = 4$  and  $x = 19$ .

**PRACTICE**

1.  $\log_3(2x + 1) + \log_3(x + 4) = 2$
2.  $\ln(3x - 4) + \ln(x + 2) = \ln(2x + 1) + \ln(x + 2)$
3.  $\log_2(5x + 1) - \log_2(x - 1) = 3$
4.  $2\log_7(x + 1) = 2$

**SOLUTIONS**

1.  $\log_3(2x + 1) + \log_3(x + 4) = 2$       Use Property 1.  
 $\log_3(2x + 1)(x + 4) = 2$       Rewrite as an exponent equation.  
 $(2x + 1)(x + 4) = 3^2$   
 $2x^2 + 9x + 4 = 9$   
 $2x^2 + 9x - 5 = 0$   
 $(2x - 1)(x + 5) = 0$

Both  $\log_3(2x + 1)$  and  $\log_3(x + 5)$  are undefined for  $x = -5$ , so the only solution is  $x = \frac{1}{2}$ .

2.  $\ln(3x - 4) + \ln(x + 2) = \ln(2x + 1) + \ln(x + 2)$       Use Property 1.  
 $\ln(3x - 4)(x + 2) = \ln(2x + 1)(x + 2)$       The logs cancel.  
 $(3x - 4)(x + 2) = (2x + 1)(x + 2)$   
 $3x^2 + 2x - 8 = 2x^2 + 5x + 2$   
 $x^2 - 3x - 10 = 0$   
 $(x - 5)(x + 2) = 0$

All of  $\ln(3x - 4)$ ,  $\ln(x + 2)$ , and  $\ln(x + 2)$  are not defined for  $x = -2$ , so the only solution is  $x = 5$ .

3.  $\log_2(5x + 1) - \log_2(x - 1) = 3$       Use Property 2.  
 $\log_2 \frac{5x + 1}{x - 1} = 3$       Rewrite as an exponent.  
 $\frac{5x + 1}{x - 1} = 2^3 = 8$       Cross-multiply.  
 $5x + 1 = 8(x - 1)$

$$5x + 1 = 8x - 8$$

$$x = 3$$

4.  $2 \log_7(x + 1) = 2$  Use Property 3.  
 $\log_7(x + 1)^2 = 2$  Rewrite as an exponent.

$$(x + 1)^2 = 7^2$$

$$(x + 1)(x + 1) = 49$$

$$x^2 + 2x + 1 = 49$$

$$x^2 + 2x - 48 = 0$$

$$(x + 8)(x - 6) = 0$$

The only solution is  $x = 6$  because  $\log_7(x + 1)$  is not defined at  $x = -8$ . We could have solved this problem in fewer steps if we had divided both sides by 2 in the first step, getting  $\log_7(x + 1) = 1$ .

The domains for  $f(x) = \log(x - 1)(x + 2)$  and  $g(x) = \log(x - 1) + \log(x + 2)$  are not the same, which *seems* to contradict the first logarithm property. Neither  $\log(x - 1)$  nor  $\log(x + 2)$  is defined for  $x = -3$  because  $-3 - 1$  and  $-3 + 2$  are negative. But  $\log(x - 1)(x + 2)$  is defined for  $x = -3$  because  $(-3 - 1)(-3 + 2)$  is *positive*. The domain of  $f(x)$  will include  $x$ -values for which both  $(x - 1)$  and  $(x + 2)$  are negative.

## The Change of Base Formula

There are countless bases for logarithms but calculators usually have only two logarithms— $\log$  and  $\ln$ . How can we use our calculators to approximate  $\log_2 5$ ? We can use the change of base formula but first, let us use logarithm properties to find this number. Let  $x = \log_2 5$ . Then  $2^x = 5$ . Take the common log of each side.

$$\log 2^x = \log 5$$

Now use the third log property.

$$x \log 2 = \log 5$$

Divide both sides by the number  $\log 2$ .

$$x = \frac{\log 5}{\log 2} \approx \frac{0.698970004}{0.301029996} \approx 2.321928095$$

This means that  $2^{2.321928095}$  is very close to 5.

We just proved that  $\log_2 5 = \frac{\log_{10} 5}{\log_{10} 2}$ . Replace 2 with  $b$ , 5 with  $x$ , and 10 with  $a$  and we have the change of base formula.

$$\log_b x = \frac{\log_a x}{\log_a b}$$

This formula converts a logarithm with old base  $b$  to new base  $a$ . Usually, the new base is either  $e$  or 10.

## EXAMPLE

- Evaluate  $\log_7 15$ . Give your solution accurate to four decimal places.

$$\begin{aligned} \log_7 15 &= \frac{\log 15}{\log 7} \approx \frac{1.176091259}{0.84509804} \approx 1.3917 \\ &= \frac{\ln 15}{\ln 7} \approx \frac{2.708050201}{1.945910149} \approx 1.3917 \end{aligned}$$

The change of base formula can be used to solve equations like  $4^{2x+1} = 8$  by rewriting the equation in logarithmic form and using the change of base formula. The equation becomes  $\log_4 8 = 2x + 1$ . Because  $\log_4 8 = \frac{\ln 8}{\ln 4}$ , the equation can be written as  $2x + 1 = \frac{\ln 8}{\ln 4}$ .

$$\begin{aligned} 2x + 1 &= \frac{\ln 8}{\ln 4} \\ 2x &= -1 + \frac{\ln 8}{\ln 4} \\ x &= \frac{1}{2} \left( -1 + \frac{\ln 8}{\ln 4} \right) = \frac{1}{4} \end{aligned}$$

## EXAMPLE

- $8^x = \frac{1}{3}$

Rewriting this as a logarithm equation, we get  $x = \log_8 \frac{1}{3}$ . Now we can use the change of base formula.

$$x = \log_8 \frac{1}{3} = \frac{\ln \frac{1}{3}}{\ln 8} \approx -0.5283$$

**PRACTICE**

Evaluate the logarithms. Give your solution accurate to four decimal places.

1.  $\log_6 25$

2.  $\log_{20} 5$

Solve for  $x$ . Give your solutions accurate to four decimal places.

3.  $3^{x+2} = 12$

4.  $15^{3x-2} = 10$

5.  $24^{3x+5} = 9$

**SOLUTIONS**

$$\begin{aligned} 1. \log_6 25 &= \frac{\ln 25}{\ln 6} \approx \frac{3.218875825}{1.791759469} \approx 1.7965 \\ &= \frac{\log 25}{\log 6} \approx \frac{1.397940009}{0.7781525} \approx 1.7965 \end{aligned}$$

$$\begin{aligned} 2. \log_{20} 5 &= \frac{\ln 5}{\ln 20} \approx \frac{1.609437912}{2.995732274} \approx 0.5372 \\ &= \frac{\log 5}{\log 20} \approx \frac{0.698970004}{1.301029996} \approx 0.5372 \end{aligned}$$

3. Rewrite  $3^{x+2} = 12$  as a logarithm equation:  $x + 2 = \log_3 12$

$$x + 2 = \log_3 12 \quad \text{Use the change of base formula.}$$

$$= \frac{\ln 12}{\ln 3}$$

$$x = -2 + \frac{\ln 12}{\ln 3} \approx 0.2619$$

4. Rewrite  $15^{3x-2} = 10$  as a logarithm equation:  $3x - 2 = \log_{15} 10$

$$3x - 2 = \log_{15} 10$$

$$= \frac{\ln 10}{\ln 15} \quad \text{Use the change of base formula.}$$

$$3x = 2 + \frac{\ln 10}{\ln 15}$$

$$x = \frac{1}{3} \left( 2 + \frac{\ln 10}{\ln 15} \right) \approx 0.9501$$

5. Rewrite  $24^{3x+5} = 9$  as a logarithm equation:  $3x + 5 = \log_{24} 9$ .

$$3x + 5 = \log_{24} 9 \quad \text{Use the change of base formula.}$$

$$= \frac{\ln 9}{\ln 24}$$

$$3x = -5 + \frac{\ln 9}{\ln 24}$$

$$x = \frac{1}{3} \left( -5 + \frac{\ln 9}{\ln 24} \right) \approx -1.4362$$

When both sides of an exponential equation have an exponent, we will use another method to solve for  $x$ . We will take either the natural log or the common log of each side and will use the third logarithm property to move the exponents in front of the logarithm. Once we have used the third logarithm property, we will perform the following steps to find  $x$ .

1. Distribute the logarithms.
2. Collect the  $x$  terms on one side of the equation and the non- $x$  terms on the other side.
3. Factor  $x$ .
4. Divide both sides of the equation by  $x$ 's coefficient (found in Step 3).



## EXAMPLES

- $3^{2x} = 2^{x+1}$

We will begin by taking the natural log of each side.

$$\ln 3^{2x} = \ln 2^{x+1} \quad \text{Use the third log property.}$$

$$2x \ln 3 = (x + 1) \ln 2$$

$$2x \ln 3 = x \ln 2 + \ln 2 \quad \text{Distribute } \ln 2 \text{ over } (x + 1).$$

Now we want both terms with an  $x$  in them on one side of the equation and the term without  $x$  in it on the other side. This means that we will move  $x \ln 2$  to the left side of the equation.

$$2x \ln 3 - x \ln 2 = \ln 2 \quad \text{Factor } x \text{ on the left side.}$$

$$x(2 \ln 3 - \ln 2) = \ln 2 \quad \text{Divide each side by } 2 \ln 3 - \ln 2.$$

$$x = \frac{\ln 2}{2 \ln 3 - \ln 2} \quad \text{We are finished here.}$$

$$x = \frac{\ln 2}{\ln \frac{9}{2}} \quad \text{This is easier to calculate.}$$

$$x \approx 0.4608$$

- $10^{x+4} = 6^{3x-1}$

Because one of the bases is 10, we will use common logarithms. This will simplify some of the steps. We will begin by taking the common log of both sides.

$$\log 10^{x+4} = \log 6^{3x-1} \quad \text{The left side simplifies to } x + 4.$$

$$x + 4 = \log 6^{3x-1} \quad \text{Use the third log property.}$$

$$x + 4 = (3x - 1) \log 6 \quad \text{Distribute } \log 6 \text{ in } (3x - 1).$$

$$x + 4 = 3x \log 6 - \log 6 \quad \text{Collect } x \text{ terms on one side.}$$

$$x - 3x \log 6 = -4 - \log 6 \quad \text{Factor } x \text{ on the left.}$$

$$x(1 - 3 \log 6) = -4 - \log 6 \quad \text{Divide both sides by } 1 - 3 \log 6.$$

$$x = \frac{-4 - \log 6}{1 - 3 \log 6} = \frac{-4 - \log 6}{1 - \log 216} \approx 3.5806$$

## PRACTICE

Solve for  $x$ . Give your solutions accurate to four decimal places.

- $4^x = 5^{x-1}$
- $6^{2x} = 8^{3x-1}$
- $10^{2-x} = 5^{x+3}$

## SOLUTIONS

- Take the natural log of each side of  $4^x = 5^{x-1}$ .

$$\ln 4^x = \ln 5^{x-1} \quad \text{Use the third log property.}$$

$$x \ln 4 = (x - 1) \ln 5$$

$$x \ln 4 = x \ln 5 - \ln 5 \quad \text{This is Step 1.}$$

$$x \ln 4 - x \ln 5 = -\ln 5 \quad \text{This is Step 2.}$$

$$x(\ln 4 - \ln 5) = -\ln 5 \quad \text{This is Step 3.}$$

$$x = \frac{-\ln 5}{\ln 4 - \ln 5} \quad \text{This is Step 4.}$$

$$\approx 7.2126$$

- Take the natural log of each side of  $6^{2x} = 8^{3x-1}$ .

$$\ln 6^{2x} = \ln 8^{3x-1} \quad \text{Use the third log property.}$$

$$2x \ln 6 = (3x - 1) \ln 8$$

$$2x \ln 6 = 3x \ln 8 - \ln 8 \quad \text{This is Step 1.}$$

$$2x \ln 6 - 3x \ln 8 = -\ln 8 \quad \text{This is Step 2.}$$

$$x(2 \ln 6 - 3 \ln 8) = -\ln 8 \quad \text{This is Step 3.}$$

$$x = \frac{-\ln 8}{2 \ln 6 - 3 \ln 8} \quad \text{This is Step 4.}$$

$$\approx 0.7833$$

3. Take the common log of each side of  $10^{2-x} = 5^{x+3}$ . This lets us use the fact that  $\log 10^{2-x} = 2 - x$ .

$$\log 10^{2-x} = \log 5^{x+3}$$

$$2 - x = (x + 3) \log 5$$

$$2 - x = x \log 5 + 3 \log 5 \quad \text{This is Step 1.}$$

$$-x - x \log 5 = -2 + 3 \log 5 \quad \text{This is Step 2.}$$

$$x(-1 - \log 5) = -2 + 3 \log 5 \quad \text{This is Step 3.}$$

$$x = \frac{-2 + 3 \log 5}{-1 - \log 5} \quad \text{This is Step 4.}$$

$$\approx -0.0570$$

## Applications of Logarithm and Exponential Equations

Now that we can solve exponential and logarithmic equations, we can solve many applied problems. We will need the compound growth formula for an investment earning interest rate  $r$ , compounded  $n$  times per year for  $t$  years,  $A(t) = P(1 + \frac{r}{n})^{nt}$  and the exponential growth formula for a population growing at the rate of  $r$  per year for  $t$  years,  $n(t) = n_0 e^{rt}$ . In the problems below, we will be looking for the time required for an investment to grow to a specified amount.

### EXAMPLES

- How long will it take for \$1000 to grow to \$1500 if it earns 8% annual interest, compounded monthly?  
In the formula  $A(t) = P(1 + \frac{r}{n})^{nt}$  we know  $A(t) = 1500$ ,  $P = 1000$ ,  $r = 0.08$ , and  $n = 12$ . We do not know  $t$ .

$$1500 = 1000 \left(1 + \frac{0.08}{12}\right)^{12t}$$

We will solve this equation for  $t$  and will round up to the nearest month.

$$1500 = 1000 \left(1 + \frac{0.08}{12}\right)^{12t} \quad \text{Divide both sides by 1000.}$$

$$1.5 = \left(1 + \frac{0.08}{12}\right)^{12t}$$

$$1.5 = 1.00667^{12t} \quad \text{Take the natural log of both sides.}$$

$$\ln 1.5 = \ln 1.00667^{12t} \quad \text{Use the third log property.}$$

$$\ln 1.5 = 12t \ln 1.00667 \quad \text{Divide both sides by } 12 \ln 1.00667.$$

$$\frac{\ln 1.5}{12 \ln 1.00667} = t$$

$$t \approx 5.085$$

In five years and one month, the investment will grow to about \$1500.

- How long will it take an investment to double if it earns  $6\frac{1}{2}\%$  annual interest, compounded daily?

An investment of \$ $P$  doubles when it grows to \$ $2P$ , so let  $A(t) = 2P$  in the compound growth formula.

$$2P = P \left(1 + \frac{0.065}{365}\right)^{365t} \quad \text{Divide both sides by } P.$$

$$2 = \left(1 + \frac{0.065}{365}\right)^{365t}$$

$$2 = 1.000178^{365t} \quad \text{Take the natural log of both sides.}$$

$$\ln 2 = \ln 1.000178^{365t} \quad \text{Use the third log property.}$$

$$\ln 2 = 365t \ln 1.000178 \quad \text{Divide both sides by } 365 \ln 1.000178.$$

$$\frac{\ln 2}{365 \ln 1.000178} = t$$

$$t \approx 10.66$$

In about 10 years, 8 months, the investment will double.

## PRACTICE

Give your answers rounded up to the nearest compounding period.

1. How long will it take \$2000 to grow to \$40,000 if it earns 9% annual interest, compounded annually?

- How long will it take for \$5000 to grow to \$7500 if it earns  $6\frac{1}{2}\%$  annual interest, compounded weekly?
- How long will it take an investment to double if it earns  $6\frac{1}{4}\%$  annual interest, compounded quarterly?

## SOLUTIONS

$$1. \quad 40,000 = 2000(1 + 0.09)^t$$

$$20 = 1.09^t$$

$$\ln 20 = \ln 1.09^t$$

$$\ln 20 = t \ln 1.09$$

$$\frac{\ln 20}{\ln 1.09} = t$$

$$34.76 \approx t$$

The \$2000 investment will grow to \$40,000 in 35 years.

$$2. \quad 7500 = 5000 \left( 1 + \frac{0.065}{52} \right)^{52t}$$

$$1.5 = 1.00125^{52t}$$

$$\ln 1.5 = \ln 1.00125^{52t}$$

$$\ln 1.5 = 52t \ln 1.00125$$

$$\frac{\ln 1.5}{52 \ln 1.00125} = t$$

$$t \approx 6.24$$

In 6 years, 13 weeks ( $0.24 \times 52 = 12.48$  rounds up to 13), the \$5000 investment will grow to \$7500.

$$3. \quad 2P = P \left( 1 + \frac{0.0625}{4} \right)^{4t}$$

$$2 = 1.015625^{4t}$$

$$\ln 2 = \ln 1.015625^{4t}$$

$$\ln 2 = 4t \ln 1.015625$$

$$\frac{\ln 2}{4 \ln 1.015625} = t$$

$$t \approx 11.18$$

In 11 years and 3 months (0.18 rounded up to the nearest quarter is 0.25, one quarter is 3 months), the investment will double.

This method works with population models where the population (either of people, animals, insects, bacteria, etc.) grows or decays at a certain percent every period. We will use the growth formula  $n(t) = n_0e^{rt}$ . If the population is decreasing, we will use the decay formula,  $n(t) = n_0e^{-rt}$ . Because we will be working with the base  $e$ , instead of taking the log of both sides, we will be rewriting the equations as log equations (this is equivalent to taking the natural log of both sides).

## EXAMPLES

- A school district estimates that its student population will grow about 5% per year for the next 15 years. How long will it take the student population to grow from the current 8000 students to 12,000?

We will solve for  $t$  in the equation  $12,000 = 8000e^{0.05t}$ .

$$12,000 = 8000e^{0.05t} \quad \text{Divide both sides by 8000.}$$

$$1.5 = e^{0.05t} \quad \text{Rewrite as a log.}$$

$$0.05t = \ln 1.5$$

$$t = \frac{\ln 1.5}{0.05} \approx 8.1$$

The population is expected to reach 12,000 in about 8 years.

- The population of a certain city in the year 2004 is about 650,000. If it is losing 2% of its population each year, when will the population decline to 500,000?

Because the population is declining, we will use the formula  $n(t) = n_0e^{-rt}$ . Solve for  $t$  in the equation  $500,000 = 650,000e^{-0.02t}$ .

$$500,000 = 650,000e^{-0.02t}$$

$$\frac{10}{13} = e^{-0.02t} \quad \text{Rewrite as a log.}$$

$$-0.02t = \ln \frac{10}{13}$$

$$t = \frac{\ln \frac{10}{13}}{-0.02} \approx 13.1$$

The population is expected to drop to 500,000 around the year 2017.

- At 2:00 a culture contained 3000 bacteria. They are growing at the rate of 150% per hour. When will there be 5400 bacteria in the culture?  
A growth rate of 150% per hour means that  $r = 1.5$  and that  $t$  is measured in hours.

$$5400 = 3000e^{1.5t}$$

$$1.8 = e^{1.5t}$$

$$1.5t = \ln 1.8$$

$$t = \frac{\ln 1.8}{1.5} \approx 0.39$$

At about 2:24 ( $0.39 \times 60 = 23.4$  minutes) there will be 5400 bacteria in the culture.

## PRACTICE

1. In 2003 a rural area had 1800 birds of a certain species. If the bird population is increasing at the rate of 15% per year, when will it reach 3000?
2. In 2002, the population of a certain city was 2 million. If the city's population is declining at the rate of 1.8% per year, when will it fall to 1.5 million?
3. At 9:00 a petrie dish contained 5000 bacteria. The bacteria population is growing at the rate of 160% per hour. When will the dish contain 20,000 bacteria?

## SOLUTIONS

$$1. \quad 3000 = 1800e^{0.15t}$$

$$\frac{5}{3} = e^{0.15t}$$

$$0.15t = \ln \frac{5}{3}$$

$$t = \frac{\ln \frac{5}{3}}{0.15} \approx 3.4$$

The bird population should reach 3000 in the year 2006.

$$2. \quad 1.5 = 2e^{-0.018t}$$

$$0.75 = e^{-0.018t}$$

$$-0.018t = \ln 0.75$$

$$t = \frac{\ln 0.75}{-0.018} \approx 16$$

In the year 2018, the population will decline to 1.5 million.

$$3. \quad 20,000 = 5000e^{1.6t}$$

$$4 = e^{1.6t}$$

$$1.6t = \ln 4$$

$$t = \frac{\ln 4}{1.6} \approx 0.87$$

At about 9:52 ( $0.87 \times 60 = 52.2$  minutes), there will be 20,000 bacteria in the dish.

## Finding the Growth Rate

We can find the growth rate of a population if we have reason to believe that it is growing exponentially and if we know the population level at two different times. We will use the first population level as  $n_0$ . Because we will know another population level, we have a value for  $n(t)$  and for  $t$ . This means that the equation  $n(t) = n_0e^{rt}$  will have only one unknown,  $r$ . We can find  $r$  using natural logarithms in the same way we found  $t$  in the problems above.

## EXAMPLES

- The population of a country is growing exponentially. In the year 2000, it was 10 million and in 2005, it was 12 million. What is the growth rate?  
In the year  $t = 0$  (2000), the population was 10 million, so  $n_0 = 10$ . The growth formula becomes  $n(t) = 10e^{rt}$ . When  $t = 5$  (the year 2005),



the population is 12 million, so  $n(t) = 12$ . We will solve the equation  $12 = 10e^{5r}$  for  $r$ .

$$12 = 10e^{5r}$$

$$1.2 = e^{5r}$$

$$5r = \ln 1.2$$

$$r = \frac{\ln 1.2}{5} \approx 0.036$$

The country's population is growing at the rate of 3.6% per year.

- Suppose a bacteria culture contains 2500 bacteria at 1:00 and at 1:30 there are 6000. What is the hourly growth rate?

Because we are asked to find the hourly growth rate,  $t$  must be measured in hours and not minutes. Initially, at  $t = 0$ , the population is 2500, so  $n_0 = 2500$ . Half an hour later, the population is 6000, so  $t = 0.5$  and  $n(t) = 6000$ . We will solve for  $r$  in the equation  $6000 = 2500e^{0.5r}$ .

$$6000 = 2500e^{0.5r}$$

$$2.4 = e^{0.5r}$$

$$0.5r = \ln 2.4$$

$$r = \frac{\ln 2.4}{0.5} \approx 1.75$$

The bacteria are increasing at the rate of 175% per hour.

- A certain species of fish is introduced in a large lake. Wildlife biologists expect the fish's population to double every four months for the first few years. What is the annual growth rate?

If  $n_0$  represents the fish's population when first put in the lake, then it will double to  $2n_0$  after  $t = 4$  months  $= \frac{4}{12}$  years  $= \frac{1}{3}$  years. The growth formula becomes  $2n_0 = n_0e^{\frac{1}{3}r}$ . This equation has two unknowns,  $n_0$  and  $r$ , not one. But after we divide both sides of the equation by  $n_0$ ,  $r$  becomes the only unknown.

$$2n_0 = n_0e^{\frac{1}{3}r}$$

$$2 = e^{\frac{1}{3}r}$$

$$\frac{1}{3}r = \ln 2$$

$$r = 3 \ln 2 \approx 2.08$$

The fish population is expected to grow at the rate of 208% per year.

## PRACTICE

1. The population of school children in a city grew from 125,000 to 200,000 in five years. Assuming exponential growth, find the annual growth rate for the number of school children.
2. A corporation that owns a chain of retail stores operated 500 stores in 2000 and 700 stores in 2003. Assuming that the number of stores is growing exponentially, what is its annual growth rate?
3. At 10:30, 1500 bacteria are present in a culture. At 11:00, 3500 are present. What is the hourly growth rate?

## SOLUTIONS

1.  $200,000 = 125,000e^{5r}$   
 $1.6 = e^{5r}$   
 $5r = \ln 1.6$   
 $r = \frac{\ln 1.6}{5} \approx 0.094$

The population of school children grew at the rate of 9.4% per year.

2.  $700 = 500e^{3r}$   
 $1.4 = e^{3r}$   
 $3r = \ln 1.4$   
 $r = \frac{\ln 1.4}{3} \approx 0.112$

The number of stores is growing at the rate of 11.2% per year.

3.  $3500 = 1500e^{0.5r}$   
 $\frac{7}{3} = e^{0.5r}$

$$0.5r = \ln \frac{7}{3}$$

$$r = \frac{\ln \frac{7}{3}}{0.5} \approx 1.69$$

The bacteria are increasing at the rate of 169% per hour.

## Radioactive Decay

Some radioactive substances decay at the rate of nearly 100% per year and others at nearly 0% per year. For this reason, we use the *half-life* of a radioactive substance to describe how fast its radioactivity decays. For example, bismuth-210 has a half-life of 5 days. After 5 days, 16 grams of bismuth-210 decays to 8 grams of bismuth-210 (and 8 grams of another substance); after 10 days, 4 grams remain, and after 15 days, only 2 grams remains. We can use logarithms and the half-life to find the rate of decay. We will use the decay formula  $n(t) = n_0 e^{-rt}$  in the following problems.

## EXAMPLES

- Find the daily decay rate of bismuth-210.  
Because its half-life is 5 days, at  $t = 5$ , one-half of  $n_0$  remains, so  $n(t) = \frac{1}{2}n_0$ .

$$\frac{1}{2}n_0 = n_0 e^{-5r} \quad \text{Divide both sides by } n_0.$$

$$\frac{1}{2} = e^{-5r} \quad \text{Rewrite as a log.}$$

$$-5r = \ln \frac{1}{2}$$

$$r = \frac{\ln \frac{1}{2}}{-5} \approx 0.1386$$

Bismuth-210 decays at the rate of 13.86% per day.

- The half-life of radium-226 is 1600 years. What is its annual decay rate?

$$\frac{1}{2}n_0 = n_0e^{-1600r} \quad \text{Divide both sides by } n_0.$$

$$\frac{1}{2} = e^{-1600r} \quad \text{Rewrite as a log.}$$

$$-1600r = \ln \frac{1}{2}$$

$$r = \frac{\ln \frac{1}{2}}{-1600} \approx 0.000433$$

The decay rate for radium-226 is about 0.0433% per year.

In the same way we found the decay rate from the half-life, we can find the half-life from the decay rate. In the formula  $\frac{1}{2}n_0 = n_0e^{-rt}$ , we know  $r$  and want to find  $t$ .

## EXAMPLE

- Suppose a radioactive substance decays at the rate of 2.5% per hour. What is its half-life?

$$\frac{1}{2}n_0 = n_0e^{-0.025t} \quad \text{Divide both sides by } n_0.$$

$$\frac{1}{2} = e^{-0.025t} \quad \text{Rewrite as a log.}$$

$$-0.025t = \ln \frac{1}{2}$$

$$t = \frac{\ln \frac{1}{2}}{-0.025} \approx 27.7$$

The half-life is 27.7 hours.

## PRACTICE

- Suppose a substance has a half-life of 45 days. Find its daily decay rate.

- The half-life of lead-210 is 22.3 years. Find its annual decay rate.
- Suppose the half-life for a substance is 1.5 seconds. What is its decay rate per second?
- Suppose a radioactive substance decays at the rate of 0.1% per day. What is its half-life?
- A radioactive substance decays at the rate of 0.02% per year. What is its half-life?

## SOLUTIONS

$$1. \quad \frac{1}{2}n_0 = n_0e^{-45r}$$

$$\frac{1}{2} = e^{-45r}$$

$$-45r = \ln \frac{1}{2}$$

$$r = \frac{\ln \frac{1}{2}}{-45} \approx 0.0154$$

The decay rate is 1.5% per day.

$$2. \quad \frac{1}{2}n_0 = n_0e^{-22.3r}$$

$$\frac{1}{2} = e^{-22.3r}$$

$$-22.3r = \ln \frac{1}{2}$$

$$r = \frac{\ln \frac{1}{2}}{-22.3} \approx 0.0311$$

The decay rate is 3.1% per year.

$$3. \quad \frac{1}{2}n_0 = n_0e^{-1.5r}$$

$$\frac{1}{2} = e^{-1.5r}$$

$$-1.5r = \ln \frac{1}{2}$$

$$r = \frac{\ln \frac{1}{2}}{-1.5} \approx 0.462$$

The substance decays at the rate of 46.2% per second.

$$4. \quad \frac{1}{2}n_0 = n_0e^{-0.001t}$$

$$\frac{1}{2} = e^{-0.001t}$$

$$-0.001t = \ln \frac{1}{2}$$

$$t = \frac{\ln \frac{1}{2}}{-0.001} \approx 693.1$$

The half-life is 693 days.

$$5. \quad \frac{1}{2}n_0 = n_0e^{-0.0002t}$$

$$\frac{1}{2} = e^{-0.0002t}$$

$$-0.0002t = \ln \frac{1}{2}$$

$$t = \frac{\ln \frac{1}{2}}{-0.0002} \approx 3466$$

The half-life is about 3466 years.

All living things have carbon-14 in them. Once they die, the carbon-14 is not replaced and begins to decay. The half-life of carbon-14 is approximately 5700 years. This information is used to find the age of many archeological finds. We will first find the annual decay rate for carbon-14 then will answer some typical carbon-14 dating questions.

$$\frac{1}{2}n_0 = n_0e^{-5700r}$$

$$\frac{1}{2} = e^{-5700r}$$

$$-5700r = \ln \frac{1}{2}$$

$$r = \frac{\ln \frac{1}{2}}{-5700} \approx 0.000121605$$

Carbon-14 decays at the rate of 0.012% per year.

### EXAMPLES

- How long will it take for 80% of the carbon-14 to decay in an animal after it has died?

If 80% of the initial amount has decayed, then 20% remains, or  $0.20n_0$ .

$$0.20n_0 = n_0e^{-0.00012t}$$

$$0.20 = e^{-0.00012t}$$

$$-0.00012t = \ln 0.20$$

$$t = \frac{\ln 0.20}{-0.00012} \approx 13,412$$

After about 13,400 years, 80% of the carbon-14 will have decayed.

- Suppose a bone is discovered and has 60% of its carbon-14. How old is the bone? 60% of its carbon-14 is  $0.60n_0$ .

$$0.60n_0 = n_0e^{-0.00012t}$$

$$0.60 = e^{-0.00012t}$$

$$-0.00012t = \ln 0.60$$

$$t = \frac{\ln 0.60}{-0.00012} \approx 4257$$

The bone is about 4260 years old.

- Suppose an animal dies today. How much of its carbon-14 will remain after 250 years?

$$n(250) = n_0e^{-0.00012(250)} \approx 0.97n_0$$

About 97% of its carbon-14 will remain after 250 years.

**PRACTICE**

1. Suppose a piece of wood from an archeological dig is being carbon-14 dated, and found to have 70% of its carbon-14 remaining. Estimate the age of the piece of wood.
2. How long would it take for an object to lose 25% of its carbon-14?
3. Suppose a tree fell 400 years ago. How much of its carbon-14 remains?

**SOLUTIONS**

1. 
$$0.70n_0 = n_0e^{-0.00012t}$$

$$0.70 = e^{-0.00012t}$$

$$-0.00012t = \ln 0.70$$

$$t = \frac{\ln 0.70}{-0.00012} \approx 2972$$

The wood is about 2970 years old.

2. An object has lost 25% of its carbon-14 when 75% of it remains.

$$0.75n_0 = n_0e^{-0.00012t}$$

$$0.75 = e^{-0.00012t}$$

$$-0.00012t = \ln 0.75$$

$$t = \frac{\ln 0.75}{-0.00012} \approx 2397$$

After about 2400 years, an object will lose 25% of its carbon-14.

3. 
$$n(400) = n_0e^{-0.00012(400)} \approx 0.953n_0$$

About 95% of its carbon-14 remains after 400 years.

**CHAPTER 9 REVIEW**

1. If \$10,000 is invested earning 6% annual interest, compounded quarterly, what will it be worth after eight years?  
 (a) \$15,938.48 (b) \$16,103.24 (c) \$11,264.93 (d) \$10,613.64



2. What is the present value of \$50,000 due in 10 years, earning 8% annual interest, compounded annually?
- (a) \$107,946.25                      (b) \$19,277.16  
(c) \$23,159.67                        (d) \$27,013.44
3. Rewrite  $\log_a x = w$  as an exponential equation.
- (a)  $a^w = x$             (b)  $a^x = w$             (c)  $x^a = w$             (d)  $w^a = x$
4. Rewrite  $7^m = n$  as a logarithmic equation.
- (a)  $\log_n 7 = m$     (b)  $\log_7 m = n$     (c)  $\log_m 7 = n$     (d)  $\log_7 n = m$
5.  $e^{\ln 7} =$
- (a)  $\ln 7$                       (b) 7                      (c)  $e^7$                       (d)  $(\ln 7)e$
6. Rewrite as a single logarithm.

$$\ln x - 2 \ln y + \ln z$$

- (a)  $\ln \frac{xz}{y^2}$             (b)  $\ln \left( \frac{xz}{y} \right)^2$             (c)  $\ln \frac{xz}{2y}$             (d)  $\frac{\ln xz}{2 \ln y}$
7. Expand the logarithm.

$$\log_5 \sqrt[3]{\frac{ab^2}{c}}$$

- (a)  $\sqrt[3]{\log_5 a + \log_5 b^2 - \log_5 c}$   
 (b)  $\frac{1}{3} \log_5 a + 2 \log_5 b - \log_5 c$   
 (c)  $\sqrt[3]{\log_5 a} + \sqrt[3]{\log_5 b^2} - \sqrt[3]{\log_5 c}$   
 (d)  $\frac{1}{3} [\log_5 a + 2 \log_5 b - \log_5 c]$
8. Solve for  $x$ :  $\log_6(x - 1) = 2$ .
- (a)  $x = 3$             (b)  $x = 37$             (c)  $x = 13$             (d)  $x = 65$
9. Solve for  $x$ :  $\log_4(x + 1) + \log_4(x - 1) = \log_4 8$ .
- (a)  $x = 4$             (b)  $x = \pm 3$             (c)  $x = 3$             (d) No solution

10. What is the domain for  $f(x) = \log(x + 4)$ ?
- (a)  $(-\infty, -4) \cup (-4, \infty)$       (b)  $(-\infty, -4)$   
 (c)  $(-4, \infty)$       (d)  $[-4, \infty)$
11. Solve for  $x$ :  $3^{x+1} = 15$ .
- (a)  $x = -1 + \frac{\ln 3}{\ln 15}$       (b)  $x = -1 + \frac{\ln 15}{\ln 3}$   
 (c)  $x = 4$       (d) No solution
12. How long will it take for an investment to double if it earns 10% annual interest, compounded quarterly?
- (a) About 4 years      (b) About 5 years  
 (c) About 6 years      (d) About 7 years
13. The half-life of a substance is about 40 years. What is its annual decay rate?
- (a) About 1%      (b) About 1.5%      (c) About 1.7%      (d) About 2.1%

## SOLUTIONS

1. B      2. C      3. A      4. D      5. B      6. A  
 7. D      8. B      9. C      10. B      11. B      12. D      13. C

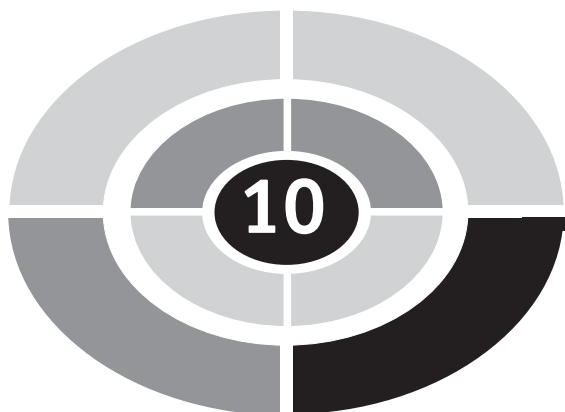

## CHAPTER

# Systems of Equations and Inequalities

A system of equations is a collection of two or more equations whose graphs might or might not intersect (share a common point or points). If the graphs do intersect, then we say that the solution to the system is the point or points where the graphs intersect. For example, the solution to the system

$$\begin{cases} x + y = 4 \\ 3x - y = 0 \end{cases}$$

is  $(1, 3)$  because the point  $(1, 3)$  is on both graphs. See Figure 10.1.

X1



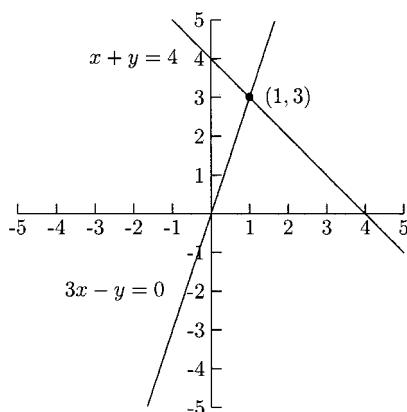

Fig. 10.1.

We say that  $(1, 3)$  *satisfies* the system because if we let  $x = 1$  and  $y = 3$  in each equation, they will both be true.

$$1 + 3 = 4 \quad \text{This is a true statement.}$$

$$3(1) - 3 = 0 \quad \text{This is a true statement.}$$

There are several methods for solving systems of equations. One of them is by sketching the graphs and seeing where, if anywhere, the graphs intersect. Even with a graphing calculator, though, these solutions might only be approximations. When the equations are lines, *matrices* can be used. Graphing calculators are useful for these, too. We will use two algebraic methods in this chapter and two matrix methods in the next. One of the algebraic methods is *substitution* and the other is *elimination by addition*. Both methods will work with many kinds of systems of equations, but we will start out with systems of linear equations.

Substitution works by solving for one variable in one equation and making a substitution in the other equation. Usually, it does not matter which variable we use or which equation we begin with, but some choices are easier than others.

## EXAMPLES

Solve the systems of equations. Put your solutions in the form of a point,  $(x, y)$ .

$$\bullet \begin{cases} x + y = 5 \\ -2x + y = -1 \end{cases}$$

We have four places to start.

1. Solve for  $x$  in the first equation:  $x = 5 - y$

2. Solve for  $y$  in the first equation:  $y = 5 - x$
3. Solve for  $x$  in the second equation:  $x = \frac{1}{2} + \frac{1}{2}y$
4. Solve for  $y$  in the second equation:  $y = 2x - 1$

The third option looks like it would be the most trouble, so we will use one of the others. We will use the first option. Because  $x = 5 - y$  came from the *first* equation, we will substitute  $5 - y$  for  $x$  in the *second* equation. Then  $-2x + y = -1$  becomes  $-2(5 - y) + y = -1$ . Now we have one equation with one variable.

$$-2(5 - y) + y = -1$$

$$-10 + 2y + y = -1$$

$$3y = 9$$

$$y = 3$$

Now that we know  $y = 3$ , we could use any of the equations above to find  $x$ . We know that  $x = 5 - y$ , so we will use this.

$$x = 5 - 3 = 2$$

The solution is  $x = 2$  and  $y = 3$  or the point  $(2, 3)$ . It is a good idea to check the solution.

$$2 + 3 = 5 \quad \text{This is true.}$$

$$-2(2) + 3 = -1 \quad \text{This is true.}$$

$$\bullet \begin{cases} 4x - y = 12 & \text{A} \\ 3x + y = 2 & \text{B} \end{cases}$$

We will solve for  $y$  in equation B:  $y = 2 - 3x$ . Next we will substitute  $2 - 3x$  for  $y$  in equation A and solve for  $x$ .

$$4x - y = 12$$

$$4x - (2 - 3x) = 12$$

$$4x - 2 + 3x = 12$$

$$7x = 14$$

$$x = 2$$

Now that we know  $x = 2$ , we will put  $x = 2$  in one of the above equations. We will use  $y = 2 - 3x$ :  $y = 2 - 3(2) = -4$ . The solution is  $x = 2$ ,  $y = -4$ , or

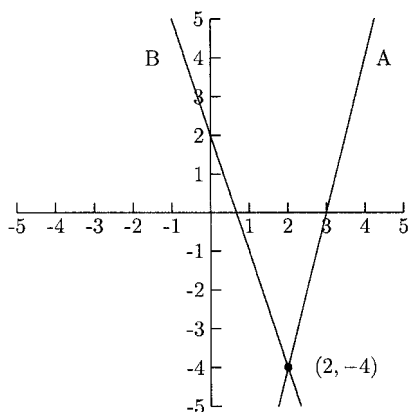

Fig. 10.2.

$(2, -4)$ . The graphs in Figure 10.2 verify that the solution  $(2, -4)$  is on both lines.

$$\bullet \begin{cases} y = 4x + 1 & A \\ y = 3x + 2 & B \end{cases}$$

Both equations are already solved for  $y$ , so all we need to do is to set them equal to each other.

$$A = B$$

$$4x + 1 = 3x + 2$$

$$x = 1$$

Use either equation A or equation B to find  $y$  when  $x = 1$ . We will use A:  $y = 4x + 1 = 4(1) + 1 = 5$ . The solution is  $x = 1$  and  $y = 5$ , or  $(1, 5)$ . We can see from the graphs in Figure 10.3 that  $(1, 5)$  is the solution to the system.

Solving a system of equations by substitution can be messy when none of the coefficients is 1. Fortunately, there is another way. We can always *add* the two equations to eliminate one of the variables. Sometimes, though, we need to multiply one or both equations by a number to make it work.

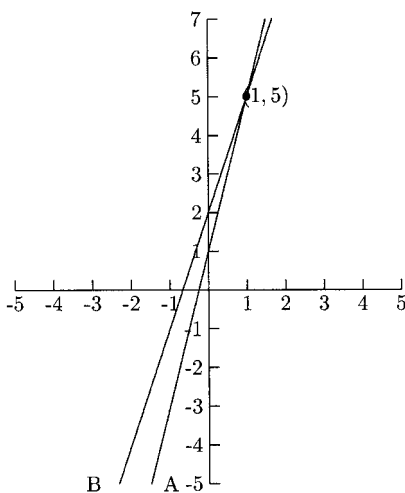

Fig. 10.3.

**EXAMPLE**

Solve the systems of equations. Put your solutions in the form of a point,  $(x, y)$ .

$$\bullet \begin{cases} 2x - 3y = 16 & \text{A} \\ 5x + 3y = -2 & \text{B} \end{cases}$$

Add the equations by adding like terms. Because we will be adding  $-3y$  to  $3y$ , the  $y$ -term will cancel, leaving one equation with only one variable.

$$2x - 3y = 16$$

$$\underline{5x + 3y = -2}$$

$$7x + 0y = 14$$

$$x = 2$$

We can put  $x = 2$  into either A or B to find  $y$ . We will put  $x = 2$  into A.

$$2x - 3y = 16$$

$$2(2) - 3y = 16$$

$$-3y = 12$$

$$y = -4$$

The solution is  $(2, -4)$ .

Sometimes we need to multiply one or both equations by some number or numbers so that one of the variables cancels. Multiplying both sides of *any* equation by a nonzero number never changes the solution.

## EXAMPLES

$$\bullet \begin{cases} 3x + 6y = -12 & \text{A} \\ 2x + 6y = -14 & \text{B} \end{cases}$$

Because the coefficients on  $y$  are the same, we only need to make one of them negative. Multiply either A or B by  $-1$ , then add.

$$\begin{array}{r} -3x - 6y = 12 \quad -\text{A} \\ \underline{2x + 6y = -14} \quad +\text{B} \\ -x = -2 \\ x = 2 \\ 3(2) + 6y = -12 \quad \text{Put } x = 2 \text{ in A} \\ y = -3 \end{array}$$

The solution is  $(2, -3)$ .

$$\bullet \begin{cases} 2x + 7y = 1 & \text{A} \\ 4x - 2y = 18 & \text{B} \end{cases}$$

Several options will work. We could multiply A by  $-2$  so that we could add  $-4x$  (in  $-2A$ ) to  $4x$  in B. We could multiply A by 2 and multiply B by 7 so that we could add  $14y$  (in  $2A$ ) to  $-14y$  (in  $7B$ ). We could also divide B by  $-2$  so that we could add  $2x$  (in A) to  $-2x$  (in  $-\frac{1}{2}B$ ). We will add  $-2A + B$ .

$$\begin{array}{r} -4x - 14y = -2 \quad -2A \\ \underline{4x - 2y = 18} \quad +B \\ -16y = 16 \\ y = -1 \\ 2x + 7(-1) = 1 \quad \text{Put } y = -1 \text{ in A} \\ x = 4 \end{array}$$

The solution is  $(4, -1)$ .

Both equations in each of the following systems will need to be changed to eliminate one of the variables.



## EXAMPLES

$$\bullet \begin{cases} 8x - 5y = -2 & A \\ 3x + 2y = 7 & B \end{cases}$$

There are many options. Some are  $3A - 8B$ ,  $-3A + 8B$ , and  $2A + 5B$ . We will compute  $2A + 5B$ .

$$16x - 10y = -4 \quad 2A$$

$$\underline{15x + 10y = 35} \quad +5B$$

$$31x = 31$$

$$x = 1$$

$$8(1) - 5y = -2 \quad \text{Put } x = 1 \text{ in } A$$

$$y = 2$$

The solution is  $(1, 2)$ .

$$\bullet \begin{cases} \frac{2}{3}x - \frac{1}{4}y = \frac{25}{72} & A \\ \frac{1}{2}x + \frac{2}{3}y = -\frac{1}{30} & B \end{cases}$$

First, we will eliminate the fractions. The LCD for A is 72, and the LCD for B is 30.

$$48x - 18y = 25 \quad 72A$$

$$15x + 12y = -1 \quad 30B$$

Now we will multiply the first equation by 2 and the second by 3.

$$96x - 36y = 50$$

$$\underline{45x + 36y = -3}$$

$$141x = 47$$

$$x = \frac{47}{141} = \frac{1}{3}$$

$$96\left(\frac{1}{3}\right) - 36y = 50$$

$$y = -\frac{1}{2}$$

The solution is  $(\frac{1}{3}, -\frac{1}{2})$ .

## Applications of Systems of Equations

Systems of two linear equations can be used to solve many kinds of word problems. In these problems, two facts will be given about two variables. Each pair of facts can be represented by a linear equation. This gives us a system of two equations with two variables.

### EXAMPLES

- A movie theater charges \$4 for each children's ticket and \$6.50 for each adult's ticket. One night 200 tickets were sold, amounting to \$1100 in ticket sales. How many of each type of ticket was sold?

Let  $x$  represent the number of children's tickets sold and  $y$ , the number of adult tickets sold. One equation comes from the fact that a total of 200 adult and children's tickets were sold, giving us  $x + y = 200$ . The other equation comes from the fact that the ticket revenue was \$1100. The ticket revenue from children's tickets is  $4x$ , and the ticket revenue from adult tickets is  $6.50y$ . Their sum is 1100 giving us  $4x + 6.50y = 1100$ .

$$\begin{cases} 4x + 6.50y = 1100 & \text{A} \\ x + y = 200 & \text{B} \end{cases}$$

We could use either substitution or addition to solve this system. Substitution is a little faster. We will solve for  $x$  in B.

$$x = 200 - y$$

$$4(200 - y) + 6.50y = 1100 \quad \text{Put } 200 - y \text{ into A}$$

$$800 - 4y + 6.50y = 1100$$

$$y = 120$$

$$x = 200 - y = 200 - 120 = 80$$

Eighty children's tickets were sold, and 120 adult tickets were sold.

- A farmer had a soil test performed. He was told that his field needed 1080 pounds of Mineral A and 920 pounds of Mineral B. Two mixtures of fertilizers provide these minerals. Each bag of Brand I provides 25 pounds of Mineral A and 15 pounds of Mineral B. Brand II provides 20 pounds of Mineral A and 20 pounds of Mineral B. How many bags of each brand should he buy?

Let  $x$  represent the number of bags of Brand I and  $y$  represent the number of bags of Brand II. Then the number of pounds of Mineral A he will get from Brand I is  $25x$  and the number of pounds of Mineral B is  $15x$ . The number

of pounds of Mineral A he will get from Brand II is  $20y$  and the number of pounds of Mineral B is  $20y$ . He needs 1080 pounds of Mineral A,  $25x$  pounds will come from Brand I and  $20y$  will come from Brand II. This gives us the equation  $25x + 20y = 1080$ . He needs 920 pounds of Mineral B,  $15x$  will come from Brand I and  $20y$  will come from Brand II. This gives us the equation  $15x + 20y = 920$ .

$$\begin{cases} 25x + 20y = 1080 & \text{A} \\ 15x + 20y = 920 & \text{B} \end{cases}$$

We will compute  $A - B$ .

$$\begin{array}{r} 25x + 20y = 1080 \quad \text{A} \\ -15x - 20y = -920 \quad -\text{B} \\ \hline 10x = 160 \\ x = 16 \\ 25(16) + 20y = 1080 \\ y = 34 \end{array}$$

He needs 16 bags of Brand I and 34 bags of Brand II.

- A furniture manufacturer has some discontinued fabric and trim in stock. He can use them on sofas and chairs. There are 160 yards of fabric and 110 yards of trim. Each sofa takes 6 yards of fabric and 4.5 yards of trim. Each chair takes 4 yards of fabric and 2 yards of trim. How many sofas and chairs should be produced in order to use all the fabric and trim?

Let  $x$  represent the number of sofas to be produced and  $y$ , the number of chairs. The manufacturer needs to use 160 yards of fabric,  $6x$  will be used on sofas and  $4y$  yards on chairs. This gives us the equation  $6x + 4y = 160$ . There are 110 yards of trim,  $4.5x$  yards will be used on the sofas and  $2y$  on the chairs. This gives us the equation  $4.5x + 2y = 110$ .

$$\begin{cases} 6x + 4y = 160 & \text{F} \\ 4.5x + 2y = 110 & \text{T} \end{cases}$$

## CHAPTER 10 Systems of Equations

We will compute  $F - 2T$ .

$$\begin{array}{r} 6x + 4y = 160 \quad F \\ -9x - 4y = -220 \quad -2T \\ \hline -3x = -60 \\ x = 20 \\ 6(20) + 4y = 160 \\ y = 10 \end{array}$$

The manufacturer needs to produce 20 sofas and 10 chairs.

### PRACTICE

For Problems 1–9, solve the systems of equations. Put your solutions in the form of a point,  $(x, y)$ .

1.

$$\begin{cases} 2x + 3y = 1 & A \\ x - 2y = -3 & B \end{cases}$$

2.

$$\begin{cases} x + y = 3 & A \\ x + 4y = 0 & B \end{cases}$$

3.

$$\begin{cases} -2x + 7y = 19 & A \\ 2x - 4y = -10 & B \end{cases}$$

4.

$$\begin{cases} 15x - y = 9 & A \\ 2x + y = 8 & B \end{cases}$$

5.

$$\begin{cases} -3x + 2y = 12 & A \\ 4x + 2y = -2 & B \end{cases}$$

6.

$$\begin{cases} 6x - 5y = 1 & \text{A} \\ 3x - 2y = 1 & \text{B} \end{cases}$$

7.

$$\begin{cases} 5x - 9y = -26 & \text{A} \\ 3x + 2y = 14 & \text{B} \end{cases}$$

8.

$$\begin{cases} 7x + 2y = 1 & \text{A} \\ 2x + 3y = -7 & \text{B} \end{cases}$$

9.

$$\begin{cases} \frac{3}{4}x + \frac{1}{5}y = \frac{23}{60} & \text{A} \\ \frac{1}{6}x - \frac{1}{4}y = -\frac{1}{9} & \text{B} \end{cases}$$

10. A grocery store sells two different brands of milk. The price for the name brand is \$3.50 per gallon, and the price for the store's brand is \$2.25 per gallon. On one Saturday, 4500 gallons of milk were sold for sales of \$12,875. How many of each brand were sold?
11. A gardener wants to add 39 pounds of Nutrient A and 16 pounds of Nutrient B to her garden. Each bag of Brand X provides 3 pounds of Nutrient A and 2 pounds of Nutrient B. Each bag of Brand Y provides 4 pounds of Nutrient A and 1 pound of Nutrient B. How many bags of each brand should she buy?
12. A clothing manufacturer has 70 yards of a certain fabric and 156 buttons in stock. It manufactures jackets and slacks that use this fabric and button. Each jacket requires  $1\frac{1}{3}$  yards of fabric and 4 buttons. Each pair of slacks required  $1\frac{3}{4}$  yards of fabric and 3 buttons. How many jackets and pairs of slacks should the manufacturer produce to use all the available fabric and buttons?

**SOLUTIONS**

1. Solve for  $x$  in B:  $x = -3 + 2y$  and substitute this for  $x$  in A.

$$\begin{aligned} 2x + 3y &= 1 \\ 2(-3 + 2y) + 3y &= 1 \\ -6 + 4y + 3y &= 1 \\ 7y &= 7 \\ y &= 1 \quad \text{Put } y = 1 \text{ in } x = -3 + 2y \\ x &= -3 + 2(1) = -1 \end{aligned}$$

The solution is  $(-1, 1)$ .

2. Solve for  $x$  in B:  $x = -4y$  and substitute this for  $x$  in A.

$$\begin{aligned} x + y &= 3 \\ -4y + y &= 3 \\ -3y &= 3 \\ y &= -1 \quad \text{Put } y = -1 \text{ in } x = -4y \\ x &= -4(-1) = 4 \end{aligned}$$

The solution is  $(4, -1)$ .

3. We will add A + B.

$$\begin{array}{r} -2x + 7y = 19 \quad \text{A} \\ \underline{2x - 4y = -10} \quad \text{+B} \\ 3y = 9 \\ y = 3 \\ -2x + 7(3) = 19 \quad \text{Put } y = 3 \text{ in A} \\ x = 1 \end{array}$$

The solution is  $(1, 3)$ .

4.

$$\begin{array}{r}
 15x - y = 9 \quad A \\
 \underline{2x + y = 8} \quad +B \\
 17x = 17 \\
 x = 1 \\
 15(1) - y = 9 \quad \text{Put } x = 1 \text{ in } A \\
 y = 6
 \end{array}$$

The solution is (1, 6).

5. We will add  $-A + B$ .

$$\begin{array}{r}
 3x - 2y = -12 \quad -A \\
 \underline{4x + 2y = -2} \quad +B \\
 7x = -14 \\
 x = -2 \\
 -3(-2) + 2y = 12 \quad \text{Put } x = -2 \text{ in } A \\
 y = 3
 \end{array}$$

The solution is (-2, 3).

6. We will compute  $A - 2B$ .

$$\begin{array}{r}
 6x - 5y = 1 \quad A \\
 \underline{-6x + 4y = -2} \quad -2B \\
 -y = -1 \\
 y = 1 \\
 6x - 5(1) = 1 \quad \text{Put } y = 1 \text{ in } A \\
 x = 1
 \end{array}$$

The solution is (1, 1).

## CHAPTER 10 Systems of Equations

7. We will compute  $3A - 5B$ .

$$\begin{array}{r} 15x - 27y = -78 \quad 3A \\ -15x - 10y = -70 \quad -5B \\ \hline \end{array}$$

$$-37y = -148$$

$$y = 4$$

$$5x - 9(4) = -26 \quad \text{Put } y = 4 \text{ in } A$$

$$x = 2$$

The solution is  $(2, 4)$ .

8. We will compute  $3A - 2B$ .

$$\begin{array}{r} 21x + 6y = 3 \quad 3A \\ -4x - 6y = 14 \quad -2B \\ \hline \end{array}$$

$$17x = 17$$

$$x = 1$$

$$7(1) + 2y = 1 \quad \text{Put } x = 1 \text{ in } A$$

$$y = -3$$

The solution is  $(1, -3)$ .

9. First clear the fractions.

$$45x + 12y = 23 \quad 60A$$

$$6x - 9y = -4 \quad 36B$$

Add 3 times the first to 4 times the second.

$$135x + 36y = 69$$

$$\underline{24x - 36y = -16}$$

$$159x = 53$$

$$x = \frac{53}{159} = \frac{1}{3}$$



$$45\left(\frac{1}{3}\right) + 12y = 23$$

$$y = \frac{2}{3}$$

The solution is  $(\frac{1}{3}, \frac{2}{3})$ .

10. Let  $x$  represent the number of gallons of the name brand sold and  $y$  represent the number of gallons of the store brand sold. The total number of gallons sold is 4500, giving us  $x + y = 4500$ . Revenue from the name brand is  $3.50x$  and is  $2.25y$  for the store brand. Total revenue is \$12,875, giving us the equation  $3.50x + 2.25y = 12,875$ .

$$\begin{cases} x + y = 4,500 \\ 3.50x + 2.25y = 12,875 \end{cases}$$

We will use substitution.

$$x = 4500 - y$$

$$3.50(4500 - y) + 2.25y = 12,875$$

$$y = 2300$$

$$x = 4500 - y = 4500 - 2300 = 2200$$

The store sold 2200 gallons of the name brand and 2300 gallons of the store brand.

11. Let  $x$  represent the number of bags of Brand X and  $y$ , the number of bags of Brand Y. She will get  $3x$  pounds of Nutrient A from  $x$  bags of Brand X and  $4y$  pounds from  $y$  bags of Brand Y, so we need  $3x + 4y = 39$ . She will get  $2x$  pounds of Nutrient B from  $x$  bags of Brand X and  $1y$  pounds of Nutrient B from  $y$  bags of Brand Y, so we need  $2x + y = 16$ . We will use substitution.

$$y = 16 - 2x$$

$$3x + 4(16 - 2x) = 39$$

$$x = 5$$

$$y = 16 - 2x = 16 - 2(5) = 6$$

The gardener needs to buy 5 bags of Brand X and 6 bags of Brand Y.

12. Let  $x$  represent the number of jackets to be produced and  $y$  the number of pairs of slacks. To use 70 yards of fabric, we need  $1\frac{1}{3}x + 1\frac{3}{4}y = 70$ . To use 156 buttons, we need  $4x + 3y = 156$ .

$$\begin{aligned}
 1\frac{1}{3}x + 1\frac{3}{4}y &= 70 \\
 \frac{4}{3}x + \frac{7}{4}y &= 70 \quad \text{F} \\
 4x + 3y &= 156 \quad \text{B} \\
 16x + 21y &= 840 \quad 12\text{F} \\
 \hline
 -16x - 12y &= -624 \quad -4\text{B} \\
 \hline
 9y &= 216 \\
 y &= 24 \\
 4x + 3(24) &= 156 \\
 x &= 21
 \end{aligned}$$

The manufacturer should produce 21 jackets and 24 pairs of slacks.

Two lines in the plane either intersect in one point, are parallel, or are really the same line. Until now, our lines have intersected in one point. When solving a system of two linear equations that are parallel or are on the same line, both variables will cancel and we are left with a true statement such as “ $3 = 3$ ” or a false statement such as “ $5 = 1$ .” We will get a true statement when the two lines are the same and a false statement when they are parallel.

### EXAMPLES

$$\bullet \begin{cases} 2x - 3y = 6 & \text{A} \\ -4x + 6y = 8 & \text{B} \end{cases}$$

$$\begin{aligned}
 4x - 6y &= 12 \quad 2\text{A} \\
 \hline
 -4x + 6y &= 8 \quad +\text{B} \\
 \hline
 0 &= 20
 \end{aligned}$$

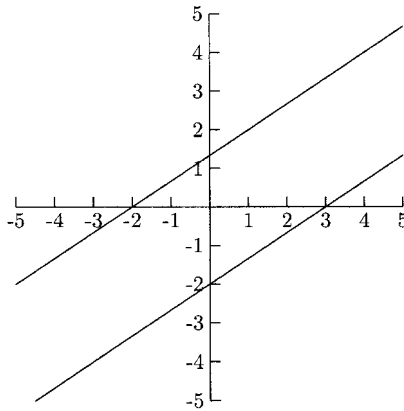

Fig. 10.4.

This is a false statement, so the lines are parallel. They are sketched in Figure 10.4

- $$\begin{cases} y = \frac{2}{3}x - 1 \\ 2x - 3y = 3 \end{cases}$$

We will use substitution.

$$2x - 3\left(\frac{2}{3}x - 1\right) = 3$$

$$2x - 2x + 3 = 3$$

$$0 = 0$$

Because  $0 = 0$  is a true statement, these lines are the same.

When the system of equations is not a pair of lines, there could be no solutions, one solution, or more than one solution. The same methods used for pairs of lines will work with other kinds of systems.

## EXAMPLES

- $$\begin{cases} y = x^2 - 2x - 3 & \text{A} \\ 3x - y = 7 & \text{B} \end{cases}$$

Elimination by addition would not work to eliminate  $x^2$  because B has no  $x^2$  term to cancel  $x^2$  in A. Solving for  $x$  in B and substituting it in for  $x$  in A

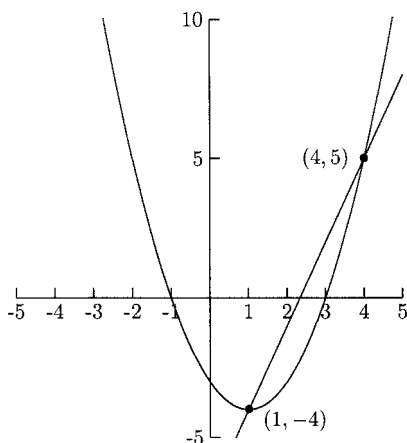

Fig. 10.5.

would work to eliminate  $x$ . Both addition and substitution will work to eliminate  $y$ . We will use addition to eliminate  $y$ .

$$\begin{array}{r}
 y = x^2 - 2x - 3 \quad \text{A} \\
 3x - y = 7 \quad \quad \quad \text{+B} \\
 \hline
 3x = x^2 - 2x + 4 \\
 0 = x^2 - 5x + 4 \\
 0 = (x - 1)(x - 4)
 \end{array}$$

The solutions occur when  $x = 1$  or  $x = 4$ . We need to find two  $y$ -values. We will let  $x = 1$  and  $x = 4$  in A.

$$y = 1^2 - 2(1) - 3 = -4 \quad (1, -4) \text{ is one solution.}$$

$$y = 4^2 - 2(4) - 3 = 5 \quad (4, 5) \text{ is the other solution.}$$

We can see from the graphs in Figure 10.5 that these solutions are correct.

- $$\begin{cases}
 x^2 + y^2 = 25 & \text{A} \\
 y = -\frac{1}{3}x^2 + 7 & \text{B}
 \end{cases}$$

We could solve for  $x^2$  in A and substitute this in B. We cannot add the equations to eliminate  $y$  or  $y^2$  because A does not have a  $y$  term to cancel  $y$  in B and B does not have a  $y^2$  term to cancel  $y^2$  in A. We will move  $-\frac{1}{3}x^2$

to the left side of B and multiply B by  $-3$ . Then we can add this to A to eliminate  $x^2$ .

$$\begin{aligned}\frac{1}{3}x^2 + y &= 7 & \text{B} \\ x^2 + y^2 &= 25 & \text{A} \\ \hline -x^2 - 3y &= -21 & -3\text{B} \\ y^2 - 3y &= 4 \\ y^2 - 3y - 4 &= 0 \\ (y - 4)(y + 1) &= 0\end{aligned}$$

The solutions occur when  $y = 4, -1$ . Put  $y = 4, -1$  in A to find their  $x$ -values.

$$x^2 + 4^2 = 25$$

$$x^2 = 9$$

$$x = \pm 3 \quad (-3, 4) \text{ and } (3, 4) \text{ are solutions.}$$

$$x^2 + (-1)^2 = 25$$

$$x^2 = 24$$

$$x = \pm\sqrt{24} = \pm 2\sqrt{6} \quad (2\sqrt{6}, -1) \text{ and } (-2\sqrt{6}, -1) \text{ are solutions.}$$

$$\bullet \begin{cases} x^2 + y^2 = 4 & \text{A} \\ y = \frac{2}{x} & \text{B} \end{cases}$$

Addition will not work on this system but substitution will. We will substitute  $y = \frac{2}{x}$  for  $y$  in A.

$$x^2 + \left(\frac{2}{x}\right)^2 = 4$$

$$x^2 + \frac{4}{x^2} = 4$$

The LCD is  $x^2$

$$x^2 \left( x^2 + \frac{4}{x^2} \right) = x^2(4)$$

$$x^4 + 4 = 4x^2$$

$$\begin{aligned}
 x^4 - 4x^2 + 4 &= 0 \\
 (x^2 - 2)(x^2 - 2) &= 0 \\
 x^2 &= 2 \\
 x &= \pm\sqrt{2}
 \end{aligned}$$

We will put  $x = \sqrt{2}$  and  $x = -\sqrt{2}$  in  $y = \frac{2}{x}$ .

$$y = \frac{2}{\sqrt{2}} = \frac{2\sqrt{2}}{\sqrt{2}\sqrt{2}} = \frac{2\sqrt{2}}{2} = \sqrt{2}; \quad (\sqrt{2}, \sqrt{2}) \text{ is a solution.}$$

$$y = \frac{2}{-\sqrt{2}} = \frac{2\sqrt{2}}{-\sqrt{2}\sqrt{2}} = \frac{2\sqrt{2}}{-2} = -\sqrt{2}; \quad (-\sqrt{2}, -\sqrt{2}) \text{ is a solution.}$$

## PRACTICE

Solve the systems of equations. Put your solutions in the form of a point,  $(x, y)$ .

1.

$$\begin{cases} y = x^2 - 4 & \text{A} \\ x + y = 8 & \text{B} \end{cases}$$

2.

$$\begin{cases} x^2 + y^2 + 6x - 2y = -5 & \text{A} \\ y = -2x - 5 & \text{B} \end{cases}$$

3.

$$\begin{cases} x^2 - y^2 = 16 & \text{A} \\ x^2 + y^2 = 16 & \text{B} \end{cases}$$

4.

$$\begin{cases} 4x^2 + y^2 = 5 & \text{A} \\ y = \frac{1}{x} & \text{B} \end{cases}$$

## SOLUTIONS

1.

$$y = x^2 - 4 \quad \text{A}$$

$$\frac{-x - y = -8}{\phantom{-x - y = -8}} \quad \text{-B}$$

$$-x = x^2 - 12$$

$$0 = x^2 + x - 12 = (x + 4)(x - 3)$$

There are solutions for  $x = -4$  and  $x = 3$ . Put these in A.

$$y = (-4)^2 - 4 = 12; \quad (-4, 12) \text{ is a solution.}$$

$$y = 3^2 - 4 = 5; \quad (3, 5) \text{ is a solution.}$$

2. Substitute  $-2x - 5$  for  $y$  in A.

$$x^2 + (-2x - 5)^2 + 6x - 2(-2x - 5) = -5$$

$$x^2 + 4x^2 + 20x + 25 + 6x + 4x + 10 = -5$$

$$5x^2 + 30x + 40 = 0 \quad \text{Divide by 5}$$

$$x^2 + 6x + 8 = 0$$

$$(x + 4)(x + 2) = 0$$

There are solutions for  $x = -4$  and  $x = -2$ . We will put these in B instead of A because there is less computation to do in B.

$$y = -2(-4) - 5 = 3; \quad (-4, 3) \text{ is a solution.}$$

$$y = -2(-2) - 5 = -1; \quad (-2, -1) \text{ is a solution.}$$

3.

$$x^2 - y^2 = 16 \quad \text{A}$$

$$\frac{x^2 + y^2 = 16}{\phantom{x^2 + y^2 = 16}} \quad \text{+B}$$

$$2x^2 = 32$$

$$x^2 = 16$$

$$x = \pm 4$$

## CHAPTER 10 Systems of Equations

Put  $x = 4$  and  $x = -4$  in A.

$$(-4)^2 - y^2 = 16 \quad 4^2 - y^2 = 16$$

$$16 - y^2 = 16 \quad 16 - y^2 = 16$$

$$y^2 = 0 \quad y^2 = 0$$

$$y = 0 \quad y = 0$$

The solutions are  $(-4, 0)$  and  $(4, 0)$ .

4. Substitute  $\frac{1}{x}$  for  $y$  in A.

$$4x^2 + \left(\frac{1}{x}\right)^2 = 5$$

$$x^2 \left(4x^2 + \frac{1}{x^2}\right) = x^2(5)$$

$$4x^4 + 1 = 5x^2$$

$$4x^4 - 5x^2 + 1 = 0$$

$$(4x^2 - 1)(x^2 - 1) = 0$$

$$(2x - 1)(2x + 1)(x - 1)(x + 1) = 0$$

The solutions are  $x = \pm\frac{1}{2}$  (from  $2x - 1 = 0$  and  $2x + 1 = 0$ ) and  $x = \pm 1$ .  
Put these in B.

$$y = \frac{1}{\frac{1}{2}} = 2; \quad \left(\frac{1}{2}, 2\right) \text{ is a solution.}$$

$$y = \frac{1}{-\frac{1}{2}} = -2; \quad \left(-\frac{1}{2}, -2\right) \text{ is a solution.}$$

$$y = \frac{1}{1} = 1; \quad (1, 1) \text{ is a solution.}$$

$$y = \frac{1}{-1} = -1; \quad (-1, -1) \text{ is a solution.}$$



## Systems of Inequalities

The solution (if any) for a system of inequalities is usually a region in the plane. The solution to a polynomial inequality (the only kind in this book) is the region above or below the curve. We will begin with linear inequalities.

When sketching the graph for an inequality, we will use a solid graph for “ $\leq$ ” and “ $\geq$ ” inequalities, and a dashed graph for “ $<$ ” and “ $>$ ” inequalities. We can decide which side of the graph to shade by choosing *any* point not on the graph itself. We will put this point into the inequality. If it makes the inequality true, we will shade the side that has that point. If it makes the inequality false, we will shade the other side. *Every* point in the shaded region is a solution to the inequality.

### EXAMPLES

- $2x + 3y \leq 6$

We will sketch the line  $2x + 3y = 6$ , using a solid line because the inequality is “ $\leq$ .”

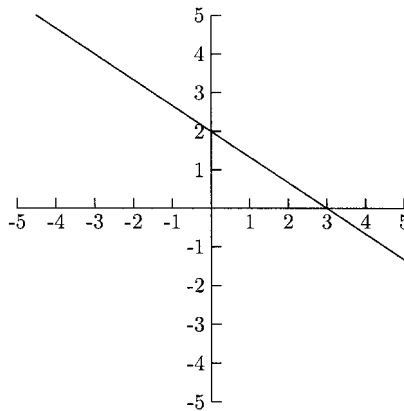

Fig. 10.6.

We will always use the origin,  $(0, 0)$  in our inequalities unless the graph goes through the origin. Does  $x = 0$  and  $y = 0$  make  $2x + 3y \leq 6$  true?  $2(0) + 3(0) \leq 6$  is a true statement, so we will shade the side that has the origin.

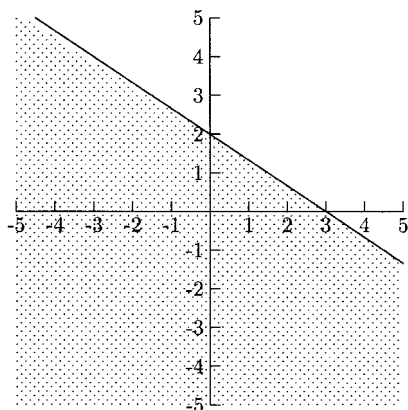

Fig. 10.7.

- $x - 2y > 4$

We will sketch the line  $x - 2y = 4$  using a dashed line because the inequality is “>.”

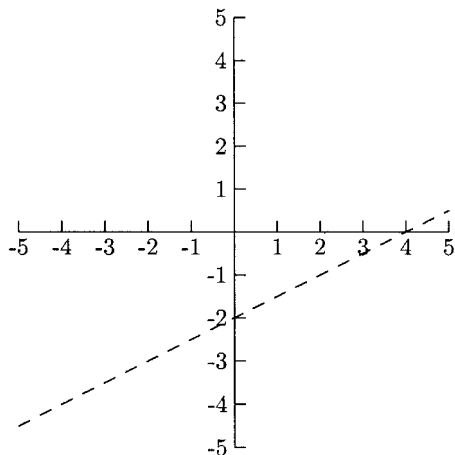

Fig. 10.8.

Now we need to decide which side of the line to shade. When we put  $(0, 0)$  in  $x - 2y > 4$ , we get the false statement  $0 - 2(0) > 4$ . We need to shade the side of the line that does *not* have the origin.

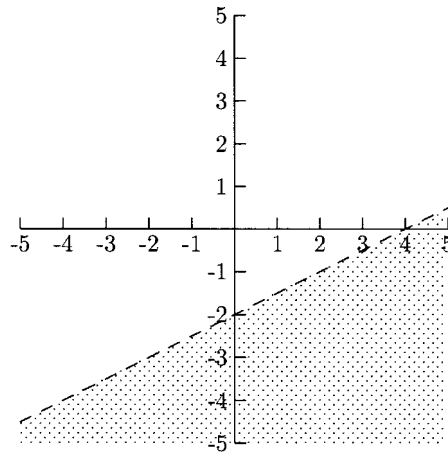

Fig. 10.9.

- $y < 3x$

We use a dashed line to sketch the line  $y = 3x$ . Because the line goes through  $(0, 0)$ , we cannot use it to determine which side of the line to shade. This is because any point on the line makes the equality true. We want to know where the inequality is true. The point  $(1, 0)$  is not on the line, so we can use it.  $0 < 3(1)$  is true so we will shade the side of the line that has the point  $(1, 0)$ , which is the right side.

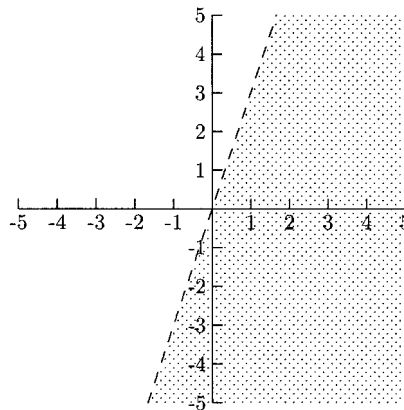

Fig. 10.10.

- $x \geq -3$

The line  $x = -3$  is a vertical line through  $x = -3$ . Because we want  $x \geq -3$  we will shade to the right of the line.

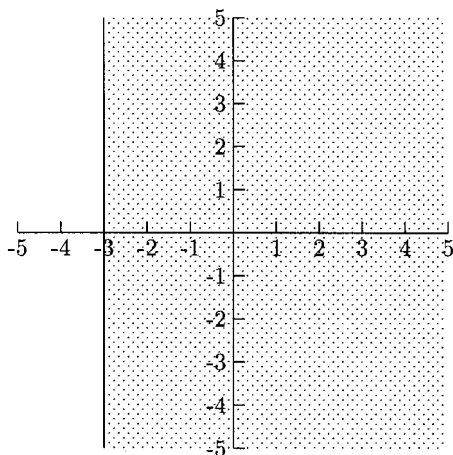

Fig. 10.11.

- $y < 2$

The line  $y = 2$  is a horizontal line at  $y = 2$ . Because we want  $y < 2$ , we will shade below the line.

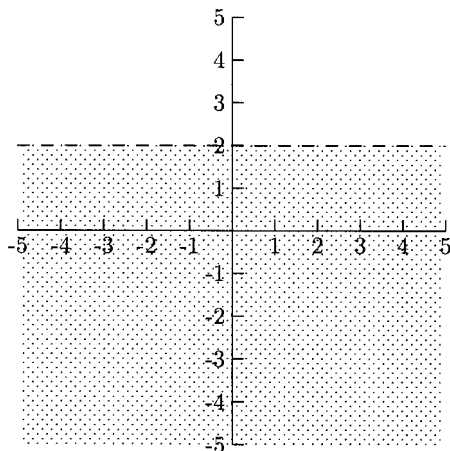

Fig. 10.12.

Graphing the solution region for nonlinear inequalities is done the same way—graph the inequality, using a solid graph for “ $\leq$ ” and “ $\geq$ ” inequalities and a dashed graph for “ $<$ ” and “ $>$ ” inequalities, then checking a point to see which side of the graph to shade.

## EXAMPLES

- $y \leq x^2 - x - 2$

The equality is  $y = x^2 - x - 2 = (x - 2)(x + 1)$ . The graph for this equation is a parabola.

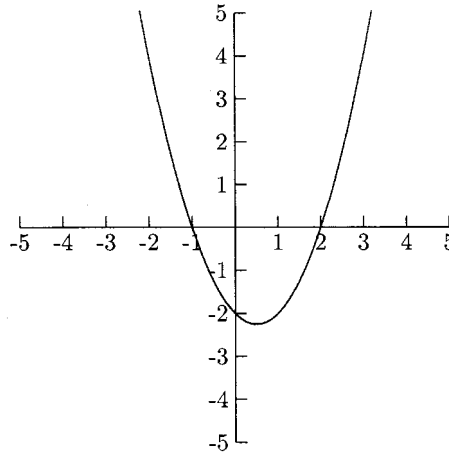

Fig. 10.13.

Because  $(0, 0)$  is not on the graph, we can use it to decide which side to shade;  $0 \leq 0^2 - 0 - 2$  is false, so we shade below the graph, the side that does not contain  $(0, 0)$ .

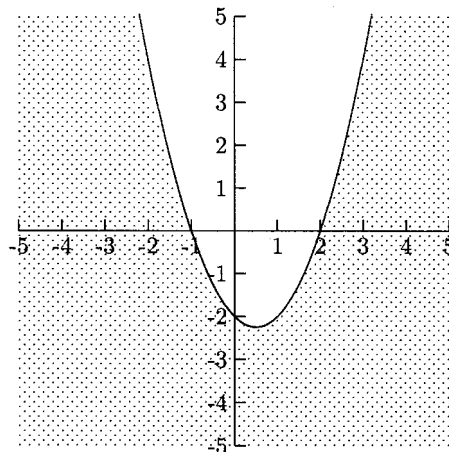

Fig. 10.14.

- $y > (x + 2)(x - 2)(x - 4)$

When we check  $(0, 0)$  in the inequality, we get the false statement  $0 > (0 + 2)(0 - 2)(0 - 4)$ . We will shade above the graph, the region that does not contain  $(0, 0)$ .

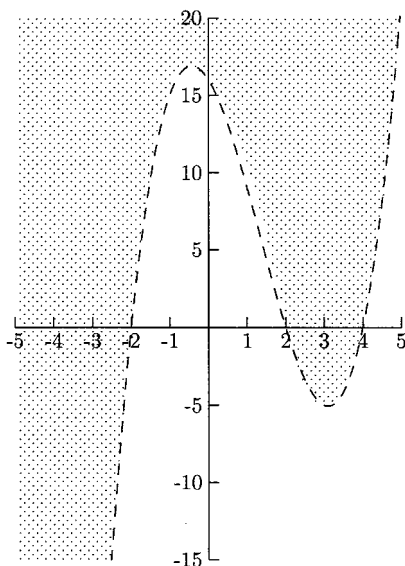

Fig. 10.15.

The solution (if there is one) to a system of two or more inequalities is the region that is part of each solution for the individual inequalities. For example, if we have a system of two inequalities and shade the solution to one inequality in blue and the other in yellow, then the solution to the system would be the region in green.

## EXAMPLES

- $$\begin{cases} x - y < 3 \\ x + 2y > 1 \end{cases}$$

Sketch the solution for each inequality. The solution to  $x - y < 3$  is the region shaded vertically. The solution to  $x + 2y > 1$  is the region shaded horizontally.

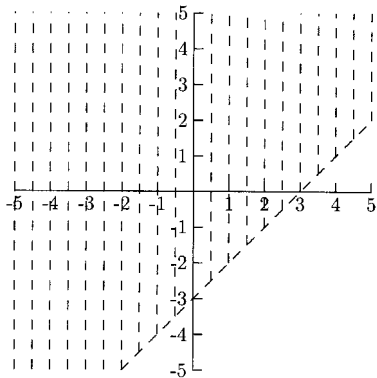

Fig. 10.16.

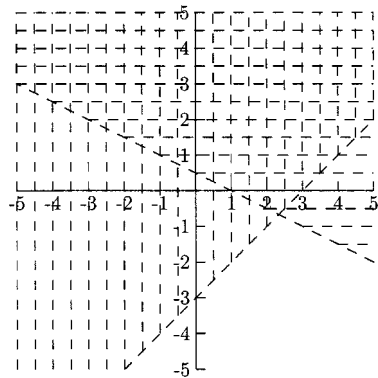

Fig. 10.17.

The region that is in both solutions is above and between the lines.

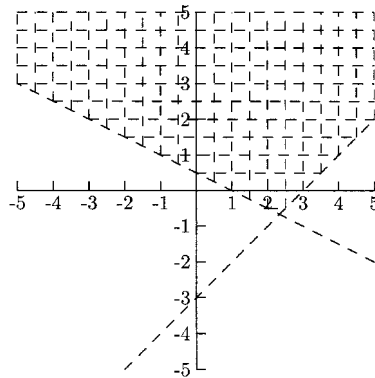

Fig. 10.18.

- $$\begin{cases} y \leq 4 - x^2 \\ x - 7y \leq 4 \end{cases}$$

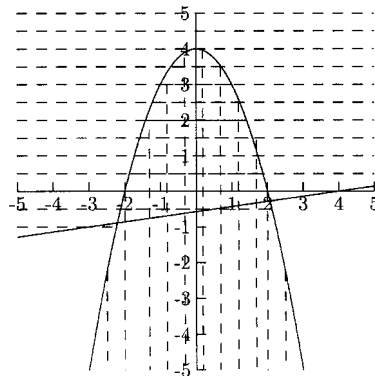

Fig. 10.19.

The solution to  $y \leq 4 - x^2$  is the region shaded vertically. The solution to  $x - 7y \leq 4$  is the region shaded horizontally. The region that is in both solutions is above the line and inside the parabola.

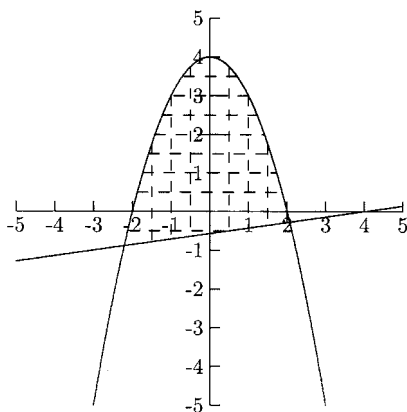

Fig. 10.20.

Because a solid graph indicates that points on the graph are also solutions, to be absolutely accurate, the correct solution uses dashed graphs for the part of the graphs that are not on the border of the shaded region.

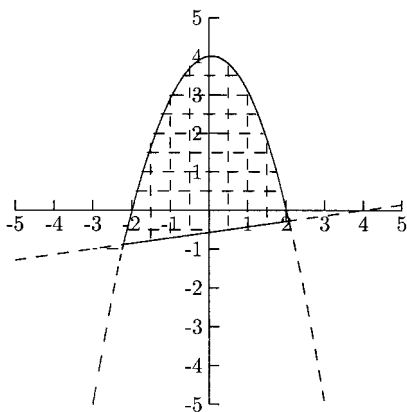

Fig. 10.21.

We will not quibble with this technicality here.

- $$\begin{cases} 2x + y \leq 5 \\ x \geq 0 \\ y \geq 0 \end{cases}$$



The inequalities  $x \geq 0$  and  $y \geq 0$  mean that we only need the top right corner of the graph. These inequalities are common in word problems.

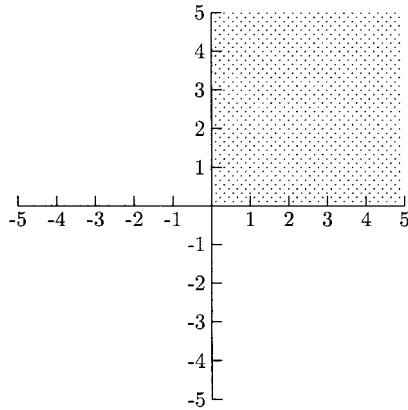

Fig. 10.22.

The solution to the system is the region in the top right corner of the graph below the line  $2x + y = 5$ .

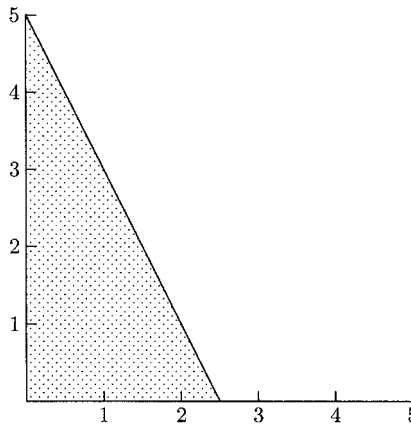

Fig. 10.23.

Some systems of inequalities have no solution. In the following example, the regions do not overlap, so there are no ordered pairs (points) that make both inequalities true.

- $$\begin{cases} y \geq x^2 + 4 \\ x - y \geq 1 \end{cases}$$

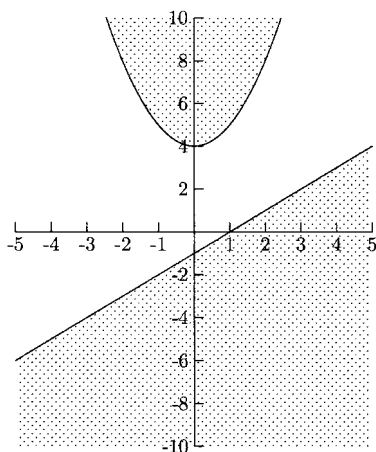

Fig. 10.24.

It is easy to lose track of the solution for a system of three or more inequalities. There are a couple of things you can do to make it easier. First, make sure the graph is large enough, using graph paper if possible. Second, shade the solution for each inequality in a different way, with different colors or shaded with horizontal, vertical, and slanted lines. The solution (if there is one) would be shaded all different ways. You could also shade one region at a time, erasing the part of the previous region that is not part of the inequality.

### EXAMPLES

- $$\begin{cases} x + y \leq 4 \\ x \geq 1 \\ y \leq x \end{cases}$$

First we will shade the solution for  $x + y \leq 4$ .

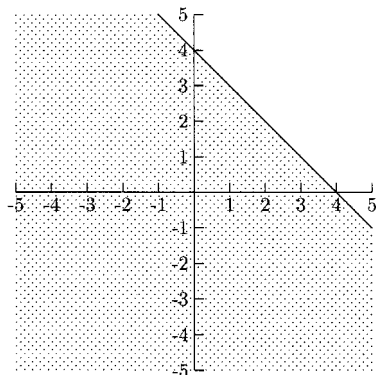

Fig. 10.25.

The region for  $x \geq 1$  is the right of the line  $x = 1$ , so we will erase the region to the *left* of  $x = 1$ .

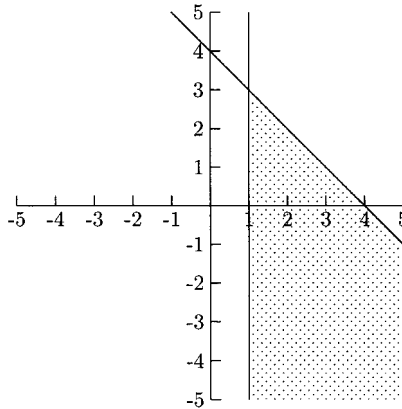

Fig. 10.26.

The solution to  $y \leq x$  is the region below the line  $y = x$ , so we will erase the shading *above* the line  $y = x$ .

The shaded region in Figure 10.27 is the solution for the system.

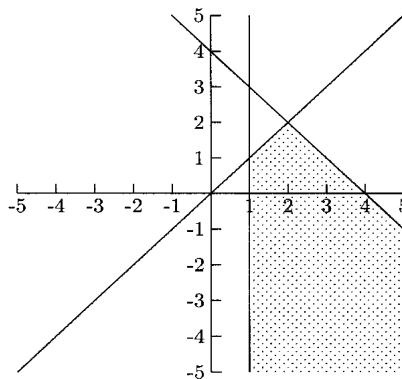

Fig. 10.27.

$$\bullet \begin{cases} y > x^2 - 16 \\ x < 2 \\ y < -5 \\ -x + y < -8 \end{cases}$$

## CHAPTER 10 Systems of Equations

We will begin with  $y > x^2 - 16$ .

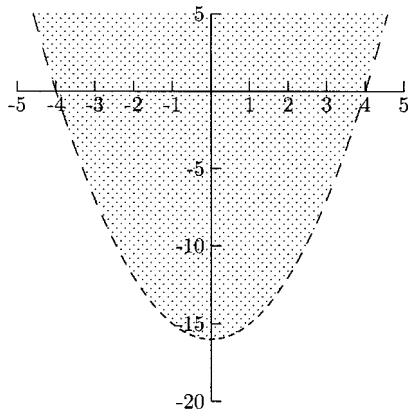

Fig. 10.28.

The solution to  $x < 2$  is the region to the left of the line  $x = 2$ . We will erase the shading to the right of  $x = 2$ .

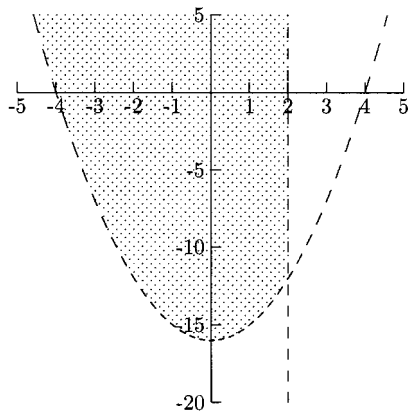

Fig. 10.29.

The solution to  $y < -5$  is the region below the line  $y = -5$ . We will erase the shading above the line  $y = -5$ .

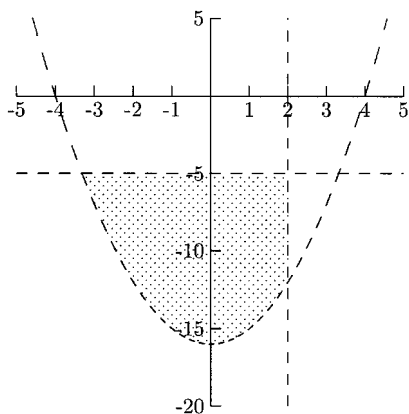

Fig. 10.30.

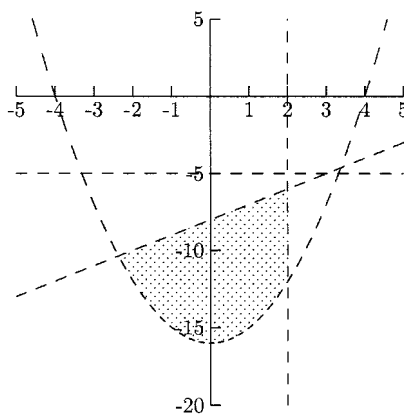

Fig. 10.31.

The solution to  $-x + y < -8$  is the region below the line  $-x + y = -8$ , so we will erase the shading above the line. The solution to the system is in Figure 10.31.

## PRACTICE

Graph the solution.

1.  $2x - 4y < 4$
2.  $x > 1$
3.  $y \leq -1$
4.  $y \leq x^2 - 4$
5.  $y > x^3$
6.  $y < |x|$
7.  $y \geq (x - 3)(x + 1)(x + 3)$
8. 
$$\begin{cases} 2x - y \leq 6 \\ x \geq 3 \end{cases}$$
9. 
$$\begin{cases} y > x^2 + 2x - 3 \\ x + y < 5 \end{cases}$$
10. 
$$\begin{cases} 2x + 3y \geq 6 \\ x \geq 0 \\ y \geq 0 \end{cases}$$

11. 
$$\begin{cases} 2x + y \geq 1 \\ -x + 2y \leq 4 \\ 5x - 3y \leq 15 \end{cases}$$

**SOLUTIONS**

1.

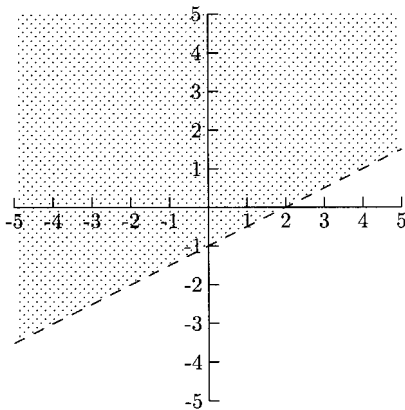

Fig. 10.32.

2.

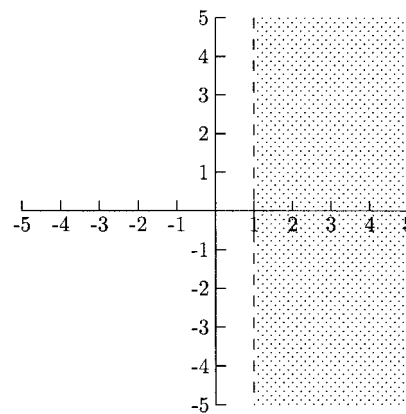

Fig. 10.33.

3.

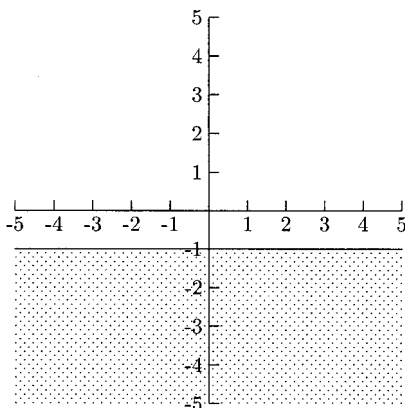

Fig. 10.34.

4.

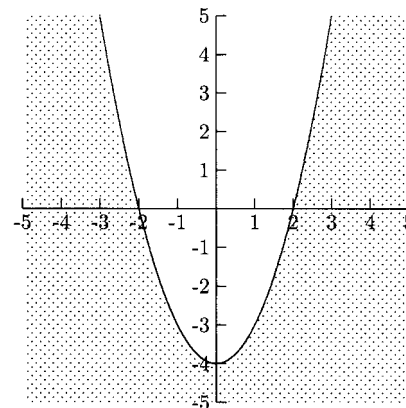

Fig. 10.35.

5.

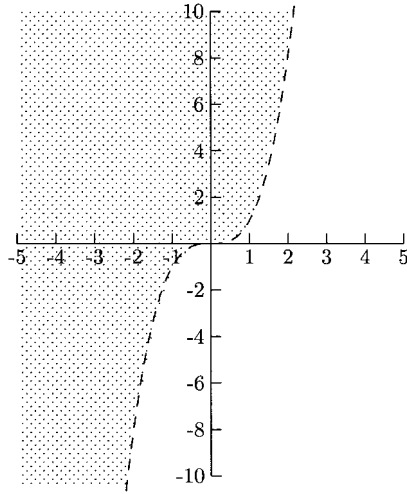

Fig. 10.36.

6.

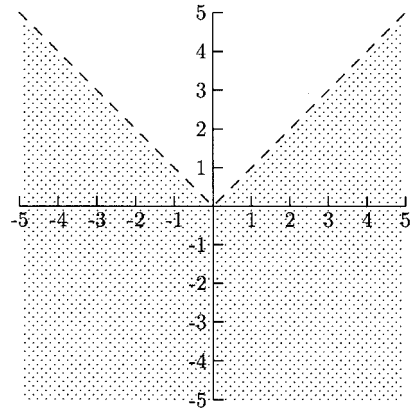

Fig. 10.37.

7.

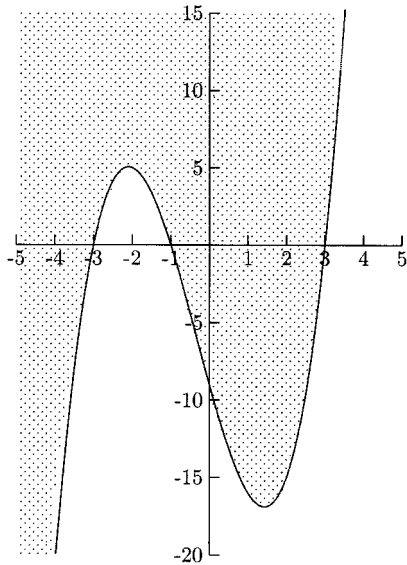

Fig. 10.38.

8.

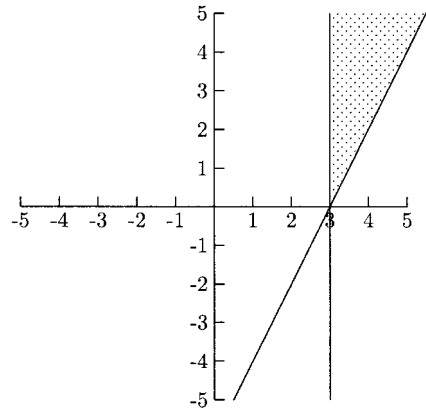

Fig. 10.39.

9.

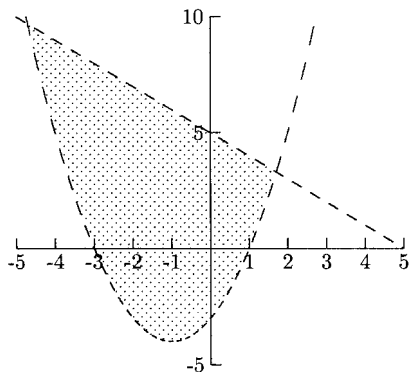

Fig. 10.40.

10.

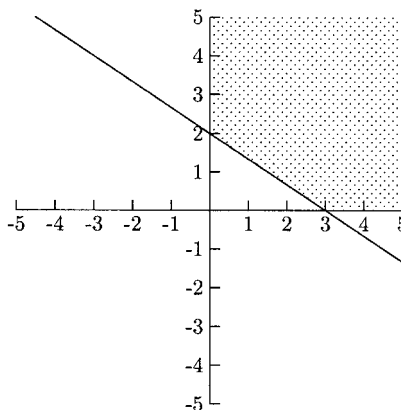

Fig. 10.41.

11.

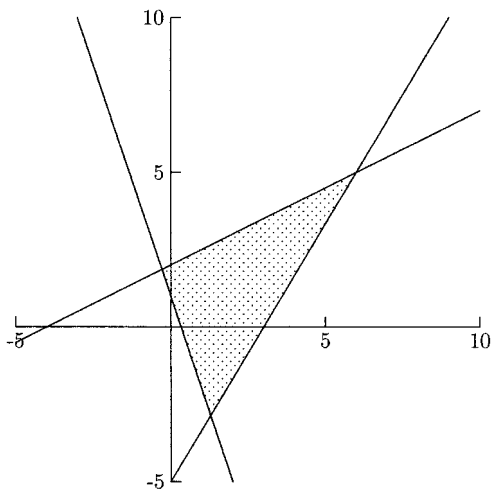

Fig. 10.42.

## CHAPTER 10 REVIEW

In some of the following problems, you will be asked to find quantities such as  $x + 2y$  for a system of equations. Solve the system and put the solution in the formula. For example, if the solution is  $x = 3$  and  $y = 5$ , then  $x + 2y$  becomes  $3 + 2(5) = 13$ .



1. Find  $x + 2y$  for the system.

$$\begin{cases} 5x - 3y = 29 \\ 2x + 3y = -1 \end{cases}$$

- (a)  $-2$                       (b)  $-1$                       (c)  $1$                       (d)  $2$

2. Find  $x + 2y$  for the system.

$$\begin{cases} y = 2x + 7 \\ y = -4x + 1 \end{cases}$$

- (a)  $8$                       (b)  $9$                       (c)  $10$                       (d)  $11$

3. Find  $x + y$  for the system.

$$\begin{cases} 3x + 2y = 16 \\ 2x + 5y = 18 \end{cases}$$

- (a)  $4$                       (b)  $5$                       (c)  $6$                       (d)  $7$

4. Find  $x + y$  for the system.

$$\begin{cases} y = x^2 - 3x - 4 \\ x - y = -8 \end{cases}$$

- (a)  $2$  and  $14$                       (b)  $3$  and  $12$                       (c)  $4$  and  $20$                       (d)  $5$  and  $15$

5. The graph in Figure 10.43 is the graph of which inequality?

- (a)  $y > 2x + 2$                       (b)  $y \geq 2x + 2$                       (c)  $y \leq 2x + 2$                       (d)  $y < 2x + 2$

6. The graph in Figure 10.44 is the graph of which inequality?

- (a)  $y > x^2 - 2x + 1$                       (b)  $y \geq x^2 - 2x + 1$   
(c)  $y \leq x^2 - 2x + 1$                       (d)  $y < x^2 - 2x + 1$

7. The graph in Figure 10.45 is the graph for which system?

- (a)  $\begin{cases} y \leq -x^2 + 4x \\ y \leq x \end{cases}$                       (b)  $\begin{cases} y \leq -x^2 + 4x \\ y \geq x \end{cases}$   
(c)  $\begin{cases} y \geq -x^2 + 4x \\ y \geq x \end{cases}$                       (d)  $\begin{cases} y \geq -x^2 + 4x \\ y \leq x \end{cases}$

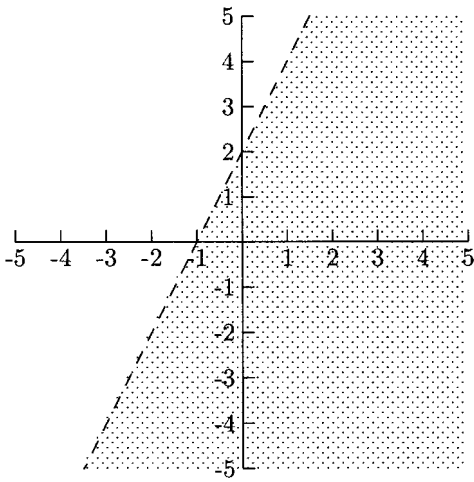

Fig. 10.43.

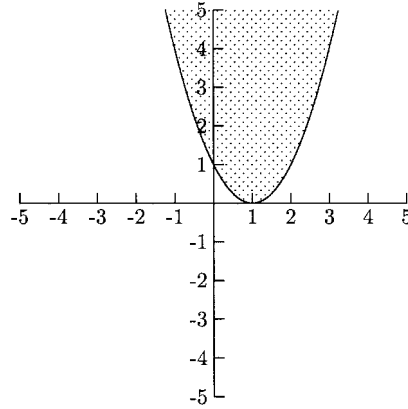

Fig. 10.44.

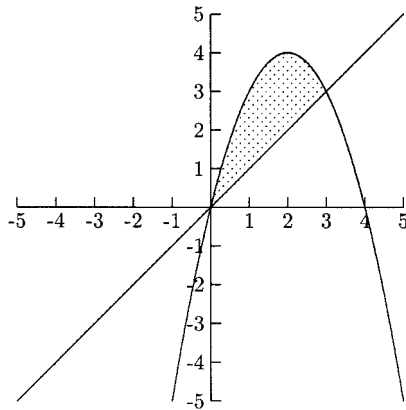

Fig. 10.45.

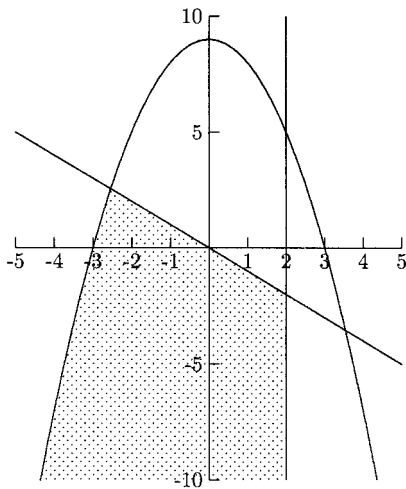

Fig. 10.46.

8. The graph in Figure 10.46 is the graph of which system?

$$(a) \begin{cases} y \leq -x^2 + 9 \\ y \geq -x \\ x \geq 2 \end{cases}$$

$$(c) \begin{cases} y \leq -x^2 + 9 \\ y \leq -x \\ x \geq 2 \end{cases}$$

$$(b) \begin{cases} y \leq -x^2 + 9 \\ y \geq -x \\ x \leq 2 \end{cases}$$

$$(d) \begin{cases} y \leq -x^2 + 9 \\ y \leq -x \\ x \leq 2 \end{cases}$$

## SOLUTIONS

1. A      2. B      3. C      4. C      5. D      6. B      7. B      8. D

# Matrices

A matrix is an array of numbers or symbols made up of rows and columns. Matrices are used in science and business to represent several variables and relationships at once. For example, suppose there are three brands of fertilizers that provide different levels of three minerals that a gardener might need. The following matrix shows how much of each mineral is provided by each brand.

	Mineral A	Mineral B	Mineral C
Brand X	6	2	1
Brand Y	2	1	2
Brand Z	1	3	6

We will learn some matrix arithmetic as well as two matrix methods used to solve systems of linear equations. Most of the calculations are tedious. Fortunately graphing calculators and computer programs (including spreadsheets) can do most of them.

## Matrix Arithmetic

The numbers in a matrix are called cells or entries. A matrix's size is given by the number of rows and columns it has. For example, a matrix that has two rows and three columns is called a  $2 \times 3$  (pronounced "2 by 3") matrix. A matrix that has the same number of rows as columns is called a square matrix.

Two matrices need to be the same size before we can add them or find their difference. The sum of two or more matrices is the sum of their corresponding entries.

$$\begin{bmatrix} 2 & -1 \\ 3 & 4 \end{bmatrix} + \begin{bmatrix} 5 & 9 \\ 4 & 1 \end{bmatrix} = \begin{bmatrix} 2+5 & -1+9 \\ 3+4 & 4+1 \end{bmatrix} = \begin{bmatrix} 7 & 8 \\ 7 & 5 \end{bmatrix}$$

Subtract one matrix from another by subtracting their corresponding entries.

$$\begin{bmatrix} 2 & -1 \\ 3 & 4 \end{bmatrix} - \begin{bmatrix} 5 & 9 \\ 4 & 1 \end{bmatrix} = \begin{bmatrix} 2-5 & -1-9 \\ 3-4 & 4-1 \end{bmatrix} = \begin{bmatrix} -3 & -10 \\ -1 & 3 \end{bmatrix}$$

The *scalar product* of a matrix is a matrix whose entries are multiplied by a fixed number.

$$3 \begin{bmatrix} 6 & -4 \\ 2 & 1 \\ 5 & 0 \end{bmatrix} = \begin{bmatrix} 3 \cdot 6 & 3 \cdot (-4) \\ 3 \cdot 2 & 3 \cdot 1 \\ 3 \cdot 5 & 3 \cdot 0 \end{bmatrix} = \begin{bmatrix} 18 & -12 \\ 6 & 3 \\ 15 & 0 \end{bmatrix}$$

It might seem that matrix multiplication is carried out the same way addition and subtraction are—multiply their corresponding entries. This operation is not very useful. The matrix multiplication operation that is useful requires more work. Two matrices do not need to be the same size, but the number of columns of the first matrix must be the same as the number of rows of the second matrix. This is because we get the entries of the product matrix by multiplying the rows of the first matrix by the columns of the second matrix. Here, we will multiply a  $3 \times 3$  matrix by a  $3 \times 2$  matrix.

$$\begin{bmatrix} A & B & C \\ D & E & F \\ G & H & I \end{bmatrix} \cdot \begin{bmatrix} K & L \\ M & N \\ O & P \end{bmatrix} = \begin{bmatrix} \text{Row 1} \times \text{Column 1} & \text{Row 1} \times \text{Column 2} \\ \text{Row 2} \times \text{Column 1} & \text{Row 2} \times \text{Column 2} \\ \text{Row 3} \times \text{Column 1} & \text{Row 3} \times \text{Column 2} \end{bmatrix}$$

Row 1 of the first matrix is  $A B C$  and Column 1 of the second matrix is  $\begin{matrix} K \\ M \\ O \end{matrix}$ . The first entry on the product matrix is Row 1  $\times$  Column 1, which is this sum.

$$\begin{array}{rcc} & \text{Row 1} & \text{Column 1} \\ & A & \times & K \\ & B & \times & M \\ + & C & \times & O \\ \hline \end{array}$$

$$\begin{bmatrix} \text{Row 1} \times \text{Column 1} & \text{Row 1} \times \text{Column 2} \\ \text{Row 2} \times \text{Column 1} & \text{Row 2} \times \text{Column 2} \\ \text{Row 3} \times \text{Column 1} & \text{Row 3} \times \text{Column 2} \end{bmatrix} = \begin{bmatrix} AK + BM + CO & AL + BN + CP \\ DK + EM + FO & DL + EN + FP \\ GK + HM + IO & GL + HN + IP \end{bmatrix}$$

**EXAMPLES**

- $$\begin{bmatrix} 1 & -8 & 2 \\ 5 & 0 & -1 \\ 2 & 1 & 1 \end{bmatrix} \cdot \begin{bmatrix} 4 & -7 \\ -2 & 1 \\ 3 & 0 \end{bmatrix}$$

$$= \begin{bmatrix} 1 \cdot 4 + (-8)(-2) + 2 \cdot 3 & 1(-7) + (-8)1 + 2 \cdot 0 \\ 5 \cdot 4 + 0(-2) + (-1)3 & 5(-7) + 0 \cdot 1 + (-1)0 \\ 2 \cdot 4 + 1(-2) + 1 \cdot 3 & 2(-7) + 1 \cdot 1 + 1 \cdot 0 \end{bmatrix} = \begin{bmatrix} 26 & -15 \\ 17 & -35 \\ 9 & -13 \end{bmatrix}$$

- $$\begin{bmatrix} -6 & 2 \\ 7 & 1 \end{bmatrix} \cdot \begin{bmatrix} 4 & 1 & 0 \\ -3 & 5 & 2 \end{bmatrix}$$

$$= \begin{bmatrix} -6 \cdot 4 + 2(-3) & -6 \cdot 1 + 2 \cdot 5 & -6 \cdot 0 + 2 \cdot 2 \\ 7 \cdot 4 + 1(-3) & 7 \cdot 1 + 1 \cdot 5 & 7 \cdot 0 + 1 \cdot 2 \end{bmatrix} = \begin{bmatrix} -30 & 4 & 4 \\ 25 & 12 & 2 \end{bmatrix}$$

An identity matrix is a square matrix with 1s on the main diagonal (from the upper left corner to the bottom right corner) and 0s everywhere else. The following are the  $2 \times 2$  and  $3 \times 3$  identity matrices.

$$\begin{bmatrix} 1 & 0 \\ 0 & 1 \end{bmatrix} \text{ and } \begin{bmatrix} 1 & 0 & 0 \\ 0 & 1 & 0 \\ 0 & 0 & 1 \end{bmatrix}$$

If we multiply any matrix by its corresponding identity matrix, we will get the original matrix back.

$$\begin{bmatrix} 1 & 0 \\ 0 & 1 \end{bmatrix} \cdot \begin{bmatrix} 3 & 6 & -2 \\ 2 & 1 & 5 \end{bmatrix} = \begin{bmatrix} 1 \cdot 3 + 0 \cdot 2 & 1 \cdot 6 + 0 \cdot 1 & 1(-2) + 0 \cdot 5 \\ 0 \cdot 3 + 1 \cdot 2 & 0 \cdot 6 + 1 \cdot 1 & 0(-2) + 1 \cdot 5 \end{bmatrix}$$

$$= \begin{bmatrix} 3 & 6 & -2 \\ 2 & 1 & 5 \end{bmatrix}$$

Matrix multiplication is not commutative. Reversing the order of the multiplication usually gets a different matrix, if the multiplication is even possible.

The matrix

$$\begin{bmatrix} 1 & -3 \\ 2 & 4 \end{bmatrix} \cdot \begin{bmatrix} 0 & 1 \\ 2 & -1 \end{bmatrix} = \begin{bmatrix} 1 \cdot 0 + (-3)2 & 1 \cdot 1 + (-3)(-1) \\ 2 \cdot 0 + 4 \cdot 2 & 2 \cdot 1 + 4(-1) \end{bmatrix} = \begin{bmatrix} -6 & 4 \\ 8 & -2 \end{bmatrix}$$

is not the same as

$$\begin{bmatrix} 0 & 1 \\ 2 & -1 \end{bmatrix} \cdot \begin{bmatrix} 1 & -3 \\ 2 & 4 \end{bmatrix} = \begin{bmatrix} 0 \cdot 1 + 1 \cdot 2 & 0(-3) + 1 \cdot 4 \\ 2 \cdot 1 + (-1)2 & 2(-3) + (-1)4 \end{bmatrix} = \begin{bmatrix} 2 & 4 \\ 0 & -10 \end{bmatrix}.$$

## PRACTICE

Compute the following.

$$1. \begin{bmatrix} 4 & 0 & -2 \\ 1 & 1 & 5 \end{bmatrix} - \begin{bmatrix} -3 & -2 & 2 \\ 6 & -4 & 3 \end{bmatrix}$$

$$2. 5 \begin{bmatrix} 3 & -6 \\ 2 & 4 \end{bmatrix}$$

$$3. \begin{bmatrix} 2 & -5 \\ 3 & 8 \end{bmatrix} \cdot \begin{bmatrix} 1 & 4 & -1 \\ 0 & -1 & 2 \end{bmatrix}$$

$$4. \begin{bmatrix} 1 & 0 & 3 \\ 2 & 1 & 0 \\ 3 & 1 & -2 \end{bmatrix} \cdot \begin{bmatrix} 4 & 2 & 1 \\ 1 & -3 & 1 \\ 3 & 6 & 2 \end{bmatrix}$$

## SOLUTIONS

$$1. \begin{bmatrix} 4 - (-3) & 0 - (-2) & -2 - 2 \\ 1 - 6 & 1 - (-4) & 5 - 3 \end{bmatrix} = \begin{bmatrix} 7 & 2 & -4 \\ -5 & 5 & 2 \end{bmatrix}$$

$$2. \begin{bmatrix} 5 \cdot 3 & 5 \cdot (-6) \\ 5 \cdot 2 & 5 \cdot 4 \end{bmatrix} = \begin{bmatrix} 15 & -30 \\ 10 & 20 \end{bmatrix}$$

$$3. \begin{bmatrix} 2 \cdot 1 + (-5)0 & 2 \cdot 4 + (-5)(-1) & 2(-1) + (-5)2 \\ 3 \cdot 1 + 8 \cdot 0 & 3 \cdot 4 + 8(-1) & 3(-1) + 8 \cdot 2 \end{bmatrix} = \begin{bmatrix} 2 & 13 & -12 \\ 3 & 4 & 13 \end{bmatrix}$$

$$4. \begin{bmatrix} 1 \cdot 4 + 0 \cdot 1 + 3 \cdot 3 & 1 \cdot 2 + 0(-3) + 3 \cdot 6 & 1 \cdot 1 + 0 \cdot 1 + 3 \cdot 2 \\ 2 \cdot 4 + 1 \cdot 1 + 0 \cdot 3 & 2 \cdot 2 + 1(-3) + 0 \cdot 6 & 2 \cdot 1 + 1 \cdot 1 + 0 \cdot 2 \\ 3 \cdot 4 + 1 \cdot 1 + (-2)3 & 3 \cdot 2 + 1(-3) + (-2)6 & 3 \cdot 1 + 1 \cdot 1 + (-2)2 \end{bmatrix}$$

$$= \begin{bmatrix} 13 & 20 & 7 \\ 9 & 1 & 3 \\ 7 & -9 & 0 \end{bmatrix}$$

## Row Operations and Inverses

We will use *row operations* to solve systems of equations and to find the multiplicative inverse of a matrix. These operations are similar to the elimination by addition method studied in Chapter 10. We will add two rows at a time (or some multiple of the rows) to make a particular entry 0. For example in the matrix  $\begin{bmatrix} 1 & -3 & 2 \\ 4 & 1 & 6 \end{bmatrix}$  we might want to change the entry with a 4 in it to 0. To do so, we can multiply the first row (Row 1) by  $-4$  and add it to the second row (Row 2).

$$-4 \text{ Row 1} = -4(1 \quad -3 \quad 2) = -4 \quad 12 \quad -8$$

$$\begin{array}{r} -4 \text{ Row 1} \quad -4 \quad 12 \quad -8 \\ +\text{Row 2} \quad \quad 4 \quad 1 \quad 6 \\ \hline \text{New Row 2} \quad 0 \quad 13 \quad -2 \end{array}$$

The matrix changes to  $\begin{bmatrix} 1 & -3 & 2 \\ 0 & 13 & -2 \end{bmatrix}$ .

### EXAMPLE

Using Row 2 and Row 3, change the entry with a 3 in it on the second row to 0.

$$\begin{bmatrix} 1 & 8 & 5 \\ -2 & 1 & 3 \\ 1 & 0 & 4 \end{bmatrix}$$

When adding the rows together, we need the last entry in each column to be opposites. If we multiply Row 2 by  $-4$  and Row 3 by 3, we will be adding  $-4(3)$  to  $3(4)$  to get 0. Multiplying Row 2 by 4 and Row 3 by  $-3$  also works.

$$\begin{array}{r} -4 \text{ Row 2} = -4(-2) \quad -4(1) \quad -4(3) = 8 \quad -4 \quad -12 \\ +3 \text{ Row 3} = 3(1) \quad 3(0) \quad 3(4) = 3 \quad 0 \quad 12 \\ \hline \text{New Row 2} \quad 11 \quad -4 \quad 0 \end{array}$$

The new matrix is  $\begin{bmatrix} 1 & 8 & 5 \\ 11 & -4 & 0 \\ 1 & 0 & 4 \end{bmatrix}$ .

Our first use for row operations is to find the inverse of a matrix (if it has one). If we multiply a matrix by its inverse, we get the corresponding identity matrix. For example,

$$\begin{bmatrix} 1 & -2 \\ -1 & 4 \end{bmatrix} \cdot \begin{bmatrix} 2 & 1 \\ \frac{1}{2} & \frac{1}{2} \end{bmatrix} = \begin{bmatrix} 1 & 0 \\ 0 & 1 \end{bmatrix}.$$



To find the inverse of  $\begin{bmatrix} A & B \\ C & D \end{bmatrix}$ , we first need to write the *augmented* matrix. An augmented matrix for this method has the original matrix on the left and the identity matrix on the right.

$$\left[ \begin{array}{cc|cc} A & B & 1 & 0 \\ C & D & 0 & 1 \end{array} \right]$$

We will use row operations to change the left half of the matrix to the  $2 \times 2$  identity matrix. The inverse matrix will be the right half of the augmented matrix in Step 6.

- Step 1** Use row operations to make the  $C$  entry a 0 for the new Row 2.  
**Step 2** Use row operations to make the  $B$  entry a 0 for the new Row 1.  
**Step 3** Write the next matrix.  
**Step 4** Divide Row 1 by the  $A$  entry.  
**Step 5** Divide Row 2 by the  $D$  entry.  
**Step 6** Write the new matrix. The inverse matrix will be the right half of this matrix.

### EXAMPLE

•  $\begin{bmatrix} 1 & -2 \\ -1 & 4 \end{bmatrix}$

The augmented matrix is  $\left[ \begin{array}{cc|cc} 1 & -2 & 1 & 0 \\ -1 & 4 & 0 & 1 \end{array} \right]$ .

- Step 1** We want to change  $-1$ , the  $C$  entry, to 0.

$$\begin{array}{rcccl} \text{Row 1} & 1 & -2 & 1 & 0 \\ +\text{Row 2} & -1 & 4 & 0 & 1 \\ \hline \text{New Row 2} & 0 & 2 & 1 & 1 \end{array}$$

- Step 2** We want to change  $-2$ , the  $B$  entry, to 0.

$$\begin{array}{rcccl} 2 \text{ Row 1} & 2 & -4 & 2 & 0 \\ + \text{Row 2} & -1 & 4 & 0 & 1 \\ \hline \text{New Row 1} & 1 & 0 & 2 & 1 \end{array}$$

**Step 3**  $\left[ \begin{array}{cc|cc} 1 & 0 & 2 & 1 \\ 0 & 2 & 1 & 1 \end{array} \right]$

- Step 4** This step is not necessary because dividing Row 1 by 1, the  $A$  entry, will not change any of its entries.

- Step 5** Divide Row 2 by 2, the  $D$  entry.  $\frac{1}{2}(0 \ 2 \ 1 \ 1) = 0 \ 1 \ \frac{1}{2} \ \frac{1}{2}$ .

$$\text{Step 6} \quad \left[ \begin{array}{cc|cc} 1 & 0 & 2 & 1 \\ 0 & 1 & \frac{1}{2} & \frac{1}{2} \end{array} \right]$$

The inverse matrix is  $\left[ \begin{array}{cc} 2 & 1 \\ \frac{1}{2} & \frac{1}{2} \end{array} \right]$ .

Finding the inverse of a  $3 \times 3$  matrix takes a few more steps. Again, we will begin by writing the augmented matrix.

$$\left[ \begin{array}{ccc|ccc} A & B & C & 1 & 0 & 0 \\ D & E & F & 0 & 1 & 0 \\ G & H & I & 0 & 0 & 1 \end{array} \right] \longrightarrow \left[ \begin{array}{ccc|ccc} A & B & C & 1 & 0 & 0 \\ D & E & F & 0 & 1 & 0 \\ G & H & I & 0 & 0 & 1 \end{array} \right]$$

We will use row operations to turn the left half of the augmented matrix into the  $3 \times 3$  identity matrix. There are many methods for getting from the first matrix to the last. The method outlined below will always work, assuming the matrix has an inverse.

**Step 1** Use Row 1 and Row 2 to make the  $D$  entry to 0 for new Row 2.

**Step 2** Use Row 1 and Row 3 to make the  $G$  entry to 0 for new Row 3.

**Step 3** Write the next matrix.  $\left[ \begin{array}{c} \text{Old Row 1} \\ \text{New Row 2} \\ \text{New Row 3} \end{array} \right]$

**Step 4** Use Row 1 and Row 2 to make the  $B$  entry a 0 for new Row 1.

**Step 5** Use Row 2 and Row 3 to make the  $H$  entry a 0 for new Row 3.

**Step 6** Write the next matrix.  $\left[ \begin{array}{c} \text{New Row 1} \\ \text{Old Row 2} \\ \text{New Row 3} \end{array} \right]$ .

**Step 7** Use Row 1 and Row 3 to make the  $C$  entry a 0 for new Row 1.

**Step 8** Use Row 2 and Row 3 to make the  $F$  entry a 0 for new Row 2.

**Step 9** Write the next matrix.  $\left[ \begin{array}{c} \text{New Row 1} \\ \text{New Row 2} \\ \text{Old Row 3} \end{array} \right]$

**Step 10** Divide Row 1 by  $A$ , Row 2 by  $E$ , and Row 3 by  $I$ . The inverse is the right half of the augmented matrix.

## EXAMPLES

- Find the inverse matrix

$$\left[ \begin{array}{ccc} 1 & 0 & -1 \\ 2 & 2 & 3 \\ 4 & -2 & 1 \end{array} \right]$$

The augmented matrix is

$$\left[ \begin{array}{ccc|ccc} 1 & 0 & -1 & 1 & 0 & 0 \\ 2 & 2 & 3 & 0 & 1 & 0 \\ 4 & -2 & 1 & 0 & 0 & 1 \end{array} \right].$$

**Step 1** Use Row 1 and Row 2 to make the  $D$  entry a 0 by computing  $-2$  Row 1 + Row 2.

$$\begin{array}{r} -2 \text{ Row 1} \quad -2 \quad 0 \quad 2 \quad -2 \quad 0 \quad 0 \\ + \text{ Row 2} \quad \quad 2 \quad 2 \quad 3 \quad \quad 0 \quad 1 \quad 0 \\ \hline \text{New Row 2} \quad 0 \quad 2 \quad 5 \quad -2 \quad 1 \quad 0 \end{array}$$

**Step 2** Use Row 1 and Row 3 to make the  $G$  entry a 0 by computing  $-4$  Row 1 + Row 3.

$$\begin{array}{r} -4 \text{ Row 1} \quad -4 \quad 0 \quad 4 \quad -4 \quad 0 \quad 0 \\ + \text{ Row 3} \quad \quad 4 \quad -2 \quad 1 \quad \quad 0 \quad 0 \quad 1 \\ \hline \text{New Row 3} \quad 0 \quad -2 \quad 5 \quad -4 \quad 0 \quad 1 \end{array}$$

**Step 3**

$$\left[ \begin{array}{ccc|ccc} 1 & 0 & -1 & 1 & 0 & 0 \\ 0 & 2 & 5 & -2 & 1 & 0 \\ 0 & -2 & 5 & -4 & 0 & 1 \end{array} \right]$$

**Step 4** This step is not necessary because the  $B$  entry is already 0. New Row 1 is old Row 1.

**Step 5** Use Row 2 and Row 3 to make the  $H$  entry a 0 by computing Row 2 + Row 3.

$$\begin{array}{r} \text{Row 2} \quad 0 \quad 2 \quad 5 \quad -2 \quad 1 \quad 0 \\ + \text{Row 3} \quad 0 \quad -2 \quad 5 \quad -4 \quad 0 \quad 1 \\ \hline \text{New Row 3} \quad 0 \quad 0 \quad 10 \quad -6 \quad 1 \quad 1 \end{array}$$

**Step 6**

$$\left[ \begin{array}{ccc|ccc} 1 & 0 & -1 & 1 & 0 & 0 \\ 0 & 2 & 5 & -2 & 1 & 0 \\ 0 & 0 & 10 & -6 & 1 & 1 \end{array} \right]$$

**Step 7** Use Row 1 and Row 3 to make the  $C$  entry a 0 by computing  $10$  Row 1 + Row 3.

$$\begin{array}{r} 10 \text{ Row 1} \quad 10 \quad 0 \quad -10 \quad 10 \quad 0 \quad 0 \\ + \text{ Row 3} \quad \quad 0 \quad 0 \quad 10 \quad -6 \quad 1 \quad 1 \\ \hline \text{New Row 1} \quad 10 \quad 0 \quad 0 \quad 4 \quad 1 \quad 1 \end{array}$$

**Step 8** Use Row 2 and Row 3 to make the  $F$  entry a 0 by computing  $-2$  Row 2 + Row 3.

$$\begin{array}{r} -2 \text{ Row 2} \quad 0 \quad -4 \quad -10 \quad 4 \quad -2 \quad 0 \\ + \text{ Row 3} \quad 0 \quad 0 \quad 10 \quad -6 \quad 1 \quad 1 \\ \hline \text{New Row 2} \quad 0 \quad -4 \quad 0 \quad -2 \quad -1 \quad 1 \end{array}$$

**Step 9**

$$\left[ \begin{array}{ccc|ccc} 10 & 0 & 0 & 4 & 1 & 1 \\ 0 & -4 & 0 & -2 & -1 & 1 \\ 0 & 0 & 10 & -6 & 1 & 1 \end{array} \right]$$

**Step 10** Divide the Row 1 by 10, the Row 2 by  $-4$ , and Row 3 by 10 to get the next matrix.

$$\left[ \begin{array}{ccc|ccc} 1 & 0 & 0 & \frac{2}{5} & \frac{1}{10} & \frac{1}{10} \\ 0 & 1 & 0 & \frac{1}{2} & \frac{1}{4} & -\frac{1}{4} \\ 0 & 0 & 1 & -\frac{3}{5} & \frac{1}{10} & \frac{1}{10} \end{array} \right]$$

The inverse matrix is

$$\left[ \begin{array}{ccc} \frac{2}{5} & \frac{1}{10} & \frac{1}{10} \\ \frac{1}{2} & \frac{1}{4} & -\frac{1}{4} \\ -\frac{3}{5} & \frac{1}{10} & \frac{1}{10} \end{array} \right].$$

- Find the inverse matrix.

$$\left[ \begin{array}{ccc} 6 & 0 & 2 \\ 1 & -1 & 0 \\ 0 & 1 & 1 \end{array} \right]$$

The augmented matrix is

$$\left[ \begin{array}{ccc|ccc} 6 & 0 & 2 & 1 & 0 & 0 \\ 1 & -1 & 0 & 0 & 1 & 0 \\ 0 & 1 & 1 & 0 & 0 & 1 \end{array} \right].$$

**Step 1** Use Row 1 and Row 2 to make the 1 entry a 0.

$$\begin{array}{r} \text{Row 1} \quad 6 \quad 0 \quad 2 \quad 1 \quad 0 \quad 0 \\ +(-6) \text{ Row 2} \quad -6 \quad 6 \quad 0 \quad 0 \quad -6 \quad 0 \\ \hline \text{New Row 1} \quad 0 \quad 6 \quad 2 \quad 1 \quad -6 \quad 0 \end{array}$$

**Step 2** This step is not necessary because 0 is already in the  $G$  entry. New Row 3 is old Row 3.

**Step 3**

$$\left[ \begin{array}{ccc|cc} 6 & 0 & 2 & 1 & 0 & 0 \\ 0 & 6 & 2 & 1 & -6 & 0 \\ 0 & 1 & 1 & 0 & 0 & 1 \end{array} \right]$$

**Step 4** This step is not necessary because the  $B$  entry is already 0. New Row 1 is old Row 1.

**Step 5** Use Row 2 and Row 3 to make the 1 entry a 0.

$$\begin{array}{r} \text{Row 2} \quad 0 \quad 6 \quad 2 \quad 1 \quad -6 \quad 0 \\ +(-6) \text{ Row 3} \quad 0 \quad -6 \quad -6 \quad 0 \quad 0 \quad -6 \\ \hline \text{New Row 3} \quad 0 \quad 0 \quad -4 \quad 1 \quad -6 \quad -6 \end{array}$$

**Step 6**

$$\left[ \begin{array}{ccc|ccc} 6 & 0 & 2 & 1 & 0 & 0 \\ 0 & 6 & 2 & 1 & -6 & 0 \\ 0 & 0 & -4 & 1 & -6 & -6 \end{array} \right]$$

**Step 7** Use Row 1 and Row 3 to make 2, the  $C$  entry, a 0.

$$\begin{array}{r} 2 \text{ Row 1} \quad 12 \quad 0 \quad 4 \quad 2 \quad 0 \quad 0 \\ + \text{ Row 3} \quad 0 \quad 0 \quad -4 \quad 1 \quad -6 \quad -6 \\ \hline \text{New Row 1} \quad 12 \quad 0 \quad 0 \quad 3 \quad -6 \quad -6 \end{array}$$

**Step 8** Use Row 2 and Row 3 to make 2, the  $F$  entry, a 0.

$$\begin{array}{r} 2 \text{ Row 2} \quad 0 \quad 12 \quad 4 \quad 2 \quad -12 \quad 0 \\ + \text{ Row 3} \quad 0 \quad 0 \quad -4 \quad 1 \quad -6 \quad -6 \\ \hline \text{New Row 2} \quad 0 \quad 12 \quad 0 \quad 3 \quad -18 \quad -6 \end{array}$$

**Step 9**

$$\left[ \begin{array}{ccc|ccc} 12 & 0 & 0 & 3 & -6 & -6 \\ 0 & 12 & 0 & 3 & -18 & -6 \\ 0 & 0 & -4 & 1 & -6 & -6 \end{array} \right]$$

**Step 10** Divide Row 1 and Row 2 by 12 and Row 3 by  $-4$ .

$$\left[ \begin{array}{ccc|ccc} 1 & 0 & 0 & \frac{1}{4} & -\frac{1}{2} & -\frac{1}{2} \\ 0 & 1 & 0 & \frac{1}{4} & -\frac{3}{2} & -\frac{1}{2} \\ 0 & 0 & 1 & -\frac{1}{4} & \frac{3}{2} & \frac{3}{2} \end{array} \right]$$

The inverse matrix is

$$\begin{bmatrix} \frac{1}{4} & -\frac{1}{2} & -\frac{1}{2} \\ \frac{1}{4} & -\frac{3}{2} & -\frac{1}{2} \\ -\frac{1}{4} & \frac{3}{2} & \frac{3}{2} \end{bmatrix}.$$

## PRACTICE

Find the inverse matrix.

1.  $\begin{bmatrix} 1 & -1 \\ 2 & 3 \end{bmatrix}$

2.  $\begin{bmatrix} -3 & 5 & 1 \\ 1 & 1 & -2 \\ 2 & -1 & 6 \end{bmatrix}$

## SOLUTIONS

1.  $\left[ \begin{array}{cc|cc} 1 & -1 & 1 & 0 \\ 2 & 3 & 0 & 1 \end{array} \right]$

**Step 1**

$$\begin{array}{r} -2 \text{ Row 1} \quad -2 \quad 2 \quad -2 \quad 0 \\ + \text{ Row 2} \quad \quad 2 \quad 3 \quad 0 \quad 1 \\ \hline \text{New Row 2} \quad 0 \quad 5 \quad -2 \quad 1 \end{array}$$

**Step 2**

$$\begin{array}{r} 3 \text{ Row 1} \quad 3 \quad -3 \quad 3 \quad 0 \\ + \text{ Row 2} \quad 2 \quad 3 \quad 0 \quad 1 \\ \hline \text{New Row 1} \quad 5 \quad 0 \quad 3 \quad 1 \end{array}$$

**Step 3**

$$\left[ \begin{array}{cc|cc} 5 & 0 & 3 & 1 \\ 0 & 5 & -2 & 1 \end{array} \right]$$

**Step 4** Divide Row 1 by 5.

**Step 5** Divide Row 2 by 5.

**Step 6**

$$\left[ \begin{array}{cc|cc} 1 & 0 & \frac{3}{5} & \frac{1}{5} \\ 0 & 1 & -\frac{2}{5} & \frac{1}{5} \end{array} \right]$$

The inverse matrix is

$$\begin{bmatrix} \frac{3}{5} & \frac{1}{5} \\ -\frac{2}{5} & \frac{1}{5} \end{bmatrix}.$$

$$2. \left[ \begin{array}{ccc|ccc} -3 & 5 & 1 & 1 & 0 & 0 \\ 1 & 1 & -2 & 0 & 1 & 0 \\ 2 & -1 & 6 & 0 & 0 & 1 \end{array} \right]$$

**Step 1**

$$\begin{array}{r} \text{Row 1} \quad -3 \quad 5 \quad 1 \quad 1 \quad 0 \quad 0 \\ +3 \text{ Row 2} \quad 3 \quad 3 \quad -6 \quad 0 \quad 3 \quad 0 \\ \hline \text{New Row 2} \quad 0 \quad 8 \quad -5 \quad 1 \quad 3 \quad 0 \end{array}$$

**Step 2**

$$\begin{array}{r} 2 \text{ Row 1} \quad -6 \quad 10 \quad 2 \quad 2 \quad 0 \quad 0 \\ +3 \text{ Row 3} \quad 6 \quad -3 \quad 18 \quad 0 \quad 0 \quad 3 \\ \hline \text{New Row 3} \quad 0 \quad 7 \quad 20 \quad 2 \quad 0 \quad 3 \end{array}$$

**Step 3**

$$\left[ \begin{array}{ccc|ccc} -3 & 5 & 1 & 1 & 0 & 0 \\ 0 & 8 & -5 & 1 & 3 & 0 \\ 0 & 7 & 20 & 2 & 0 & 3 \end{array} \right]$$

**Step 4**

$$\begin{array}{r} 8 \text{ Row 1} \quad -24 \quad 40 \quad 8 \quad 8 \quad 0 \quad 0 \\ +(-5) \text{ Row 2} \quad 0 \quad -40 \quad 25 \quad -5 \quad -15 \quad 0 \\ \hline \text{New Row 1} \quad -24 \quad 0 \quad 33 \quad 3 \quad -15 \quad 0 \end{array}$$

**Step 5**

$$\begin{array}{r} -7 \text{ Row 2} \quad 0 \quad -56 \quad 35 \quad -7 \quad -21 \quad 0 \\ +8 \text{ Row 3} \quad 0 \quad 56 \quad 160 \quad 16 \quad 0 \quad 24 \\ \hline \text{New Row 3} \quad 0 \quad 0 \quad 195 \quad 9 \quad -21 \quad 24 \end{array}$$

**Step 6**

$$\left[ \begin{array}{ccc|ccc} -24 & 0 & 33 & 3 & -15 & 0 \\ 0 & 8 & -5 & 1 & 3 & 0 \\ 0 & 0 & 195 & 9 & -21 & 24 \end{array} \right]$$

To make the numbers smaller, replace Row 1 with  $\frac{1}{3}$  Row 1 and Row 3 by  $\frac{1}{3}$  Row 3.

$$\left[ \begin{array}{ccc|ccc} -8 & 0 & 11 & 1 & -5 & 0 \\ 0 & 8 & -5 & 1 & 3 & 0 \\ 0 & 0 & 65 & 3 & -7 & 8 \end{array} \right]$$

**Step 7**

$$\begin{array}{r} 65 \text{ Row 1} \quad -520 \quad 0 \quad 715 \quad 65 \quad -325 \quad 0 \\ +(-11) \text{ Row 3} \quad 0 \quad 0 \quad -715 \quad -33 \quad 77 \quad -88 \\ \hline \text{New Row 1} \quad -520 \quad 0 \quad 0 \quad 32 \quad -248 \quad -88 \end{array}$$

**Step 8**

$$\begin{array}{r}
 13 \text{ Row 2} \quad 0 \quad 104 \quad -65 \quad 13 \quad 39 \quad 0 \\
 + \text{ Row 3} \quad 0 \quad 0 \quad 65 \quad 3 \quad -7 \quad 8 \\
 \hline
 \text{New Row 2} \quad 0 \quad 104 \quad 0 \quad 16 \quad 32 \quad 8
 \end{array}$$

**Step 9**

$$\left[ \begin{array}{ccc|ccc}
 -520 & 0 & 0 & 32 & -248 & -88 \\
 0 & 104 & 0 & 16 & 32 & 8 \\
 0 & 0 & 65 & 3 & -7 & 8
 \end{array} \right].$$

**Step 10** Divide Row 1 by  $-520$ , Row 2 by  $104$ , and Row 3 by  $65$ .

$$\left[ \begin{array}{ccc|ccc}
 1 & 0 & 0 & -\frac{4}{65} & \frac{31}{65} & \frac{11}{65} \\
 0 & 1 & 0 & \frac{2}{13} & \frac{4}{13} & \frac{1}{13} \\
 0 & 0 & 1 & \frac{3}{65} & -\frac{7}{65} & \frac{8}{65}
 \end{array} \right]$$

The inverse matrix is

$$\left[ \begin{array}{ccc}
 -\frac{4}{65} & \frac{31}{65} & \frac{11}{65} \\
 \frac{2}{13} & \frac{4}{13} & \frac{1}{13} \\
 \frac{3}{65} & -\frac{7}{65} & \frac{8}{65}
 \end{array} \right].$$

## Matrices and Systems of Equations

There are three ways we can use matrices to solve a system of linear equations. Two of them will be discussed in this book. Solving systems using these methods will be very much like finding inverses. We will begin with  $2 \times 2$  systems (two equations and two variables) and an augmented matrix of the form  $\left[ \begin{array}{cc|c} A & B & E \\ C & D & F \end{array} \right]$ .  $A$ ,  $B$ ,  $C$ , and  $D$  are the coefficients of  $x$  and  $y$  in the equations and  $E$  and  $F$  are the constant terms. We will use the same steps above to change this matrix to one of the form  $\left[ \begin{array}{cc|c} 1 & 0 & \text{number} \\ 0 & 1 & \text{number} \end{array} \right]$ . The numbers in the last column will be the solution.

### EXAMPLE

$$\bullet \quad \begin{cases} 2x - 3y = 17 \\ -x + y = -7 \end{cases}$$

The coefficients  $2$ ,  $-3$ ,  $-1$ , and  $1$  are the entries in the left side of the matrix.

The constant terms  $17$  and  $-7$  are the entries on the right side of the matrix.

The augmented matrix is  $\left[ \begin{array}{cc|c} 2 & -3 & 17 \\ -1 & 1 & -7 \end{array} \right]$ .



**Step 1** We want  $-1$ , the  $C$  entry, to be  $0$ .

$$\begin{array}{r} \text{Row 1} \quad 2 \quad -3 \quad 17 \\ +2 \text{ Row 2} \quad -2 \quad 2 \quad -14 \\ \hline \text{New Row 2} \quad 0 \quad -1 \quad 3 \end{array}$$

**Step 2** We want  $-3$ , the  $B$  entry, to be  $0$ .

$$\begin{array}{r} \text{Row 1} \quad 2 \quad -3 \quad 17 \\ +3 \text{ Row 2} \quad -3 \quad 3 \quad -21 \\ \hline \text{New Row 1} \quad -1 \quad 0 \quad -4 \end{array}$$

**Step 3**

$$\left[ \begin{array}{cc|c} -1 & 0 & -4 \\ 0 & -1 & 3 \end{array} \right] \quad \begin{array}{l} \text{This row represents the equation } -1x + 0y = -4 \\ \text{This row represents the equation } 0x + (-1)y = 3 \end{array}$$

**Step 4** Divide Row 1 by  $-1$ .

**Step 5** Divide Row 2 by  $-1$ .

**Step 6**

$$\left[ \begin{array}{cc|c} 1 & 0 & 4 \\ 0 & 1 & -3 \end{array} \right] \quad \begin{array}{l} \text{This row represents the equation } 1x + 0y = 4. \\ \text{This row represents the equation } 0x + 1y = -3. \end{array}$$

The solution is  $x = 4$  and  $y = -3$ .

Begin solving a  $3 \times 3$  system (three equations and three variables) by writing

the augmented matrix  $\left[ \begin{array}{ccc|c} A & B & C & J \\ D & E & F & K \\ G & H & I & L \end{array} \right]$ . Using the same steps we used to find

the inverse of a matrix, we want to change this matrix to one of the form

$$\left[ \begin{array}{ccc|c} 1 & 0 & 0 & \text{number} \\ 0 & 1 & 0 & \text{number} \\ 0 & 0 & 1 & \text{number} \end{array} \right]. \text{ The numbers in the fourth column will be the solution.}$$

## EXAMPLE

$$\bullet \begin{cases} x + 3z = 3 \\ -x + y - z = 5 \\ 2x + y = -2 \end{cases}$$

The augmented matrix is  $\left[ \begin{array}{ccc|c} 1 & 0 & 3 & 3 \\ -1 & 1 & -1 & 5 \\ 2 & 1 & 0 & -2 \end{array} \right]$ .

**Step 1** Use Row 1 and Row 2 to change the  $D$  entry to 0.

$$\begin{array}{r} \text{Row 1} \quad 1 \quad 0 \quad 3 \quad 3 \\ + \text{Row 2} \quad -1 \quad 1 \quad -1 \quad 5 \\ \hline \text{New Row 2} \quad 0 \quad 1 \quad 2 \quad 8 \end{array}$$

**Step 2** Use Row 1 and Row 3 to change the  $G$  entry to 0.

$$\begin{array}{r} -2 \text{ Row 1} \quad -2 \quad 0 \quad -6 \quad -6 \\ + \text{Row 3} \quad 2 \quad 1 \quad 0 \quad -2 \\ \hline \text{New Row 3} \quad 0 \quad 1 \quad -6 \quad -8 \end{array}$$

**Step 3**

$$\left[ \begin{array}{ccc|c} 1 & 0 & 3 & 3 \\ 0 & 1 & 2 & 8 \\ 0 & 1 & -6 & -8 \end{array} \right]$$

**Step 4** Because the  $B$  entry is already 0, this step is not necessary. New Row 1 is old Row 1.

**Step 5** Use Row 2 and Row 3 to change the  $H$  entry to 0.

$$\begin{array}{r} -\text{Row 2} \quad 0 \quad -1 \quad -2 \quad -8 \\ + \text{Row 3} \quad 0 \quad 1 \quad -6 \quad -8 \\ \hline \text{New Row 3} \quad 0 \quad 0 \quad -8 \quad -16 \end{array}$$

**Step 6**

$$\left[ \begin{array}{ccc|c} 1 & 0 & 3 & 3 \\ 0 & 1 & 2 & 8 \\ 0 & 0 & -8 & -16 \end{array} \right]$$

**Step 7** Use Row 1 and Row 3 to make the  $C$  entry a 0.

$$\begin{array}{r} 8 \text{ Row 1} \quad 8 \quad 0 \quad 24 \quad 24 \\ +3 \text{ Row 3} \quad 0 \quad 0 \quad -24 \quad -48 \\ \hline \text{New Row 1} \quad 8 \quad 0 \quad 0 \quad -24 \end{array}$$

**Step 8** Use Row 2 and Row 3 to make the  $F$  entry a 0.

$$\begin{array}{r} 4 \text{ Row 2} \quad 0 \quad 4 \quad 8 \quad 32 \\ + \text{Row 3} \quad 0 \quad 0 \quad -8 \quad -16 \\ \hline \text{New Row 2} \quad 0 \quad 4 \quad 0 \quad 16 \end{array}$$

**Step 9**

$$\left[ \begin{array}{ccc|c} 8 & 0 & 0 & -24 \\ 0 & 4 & 0 & 16 \\ 0 & 0 & -8 & -16 \end{array} \right]$$

**Step 10** Divide Row 1 by 8, Row 2 by 4, and Row 3 by  $-8$ .

$$\left[ \begin{array}{ccc|c} 1 & 0 & 0 & -3 \\ 0 & 1 & 0 & 4 \\ 0 & 0 & 1 & 2 \end{array} \right] \text{The solution is } x = -3, y = 4, \text{ and } z = 2.$$

The second method we will use to solve systems of equations involves finding the inverse of a matrix and multiplying two matrices. We begin by creating the coefficient matrix and the constant matrix for the system.

$$\begin{cases} Ax + By = E \\ Cx + Dy = F \end{cases}$$

The coefficient matrix is  $\begin{bmatrix} A & B \\ C & D \end{bmatrix}$  and the constant matrix is  $\begin{bmatrix} E \\ F \end{bmatrix}$ . We will find the inverse of the coefficient matrix and multiply the inverse by the constant matrix. The product matrix will consist of one column of two numbers. These two numbers will be the solution to the system.

### EXAMPLE

$$\bullet \begin{cases} -2x + y = -7 \\ x - 3y = 1 \end{cases}$$

The coefficient matrix and constant matrix are

$$\begin{bmatrix} -2 & 1 \\ 1 & -3 \end{bmatrix} \text{ and } \begin{bmatrix} -7 \\ 1 \end{bmatrix}.$$

$$\left[ \begin{array}{cc|cc} -2 & 1 & 1 & 0 \\ 1 & -3 & 0 & 1 \end{array} \right]$$

$$\begin{array}{rcc} \text{Row 1} & -2 & 1 & 1 & 0 & & 3 \text{ Row 1} & -6 & 3 & 3 & 0 \\ +2 \text{ Row 2} & 2 & -6 & 0 & 2 & \text{and} & + \text{ Row 2} & 1 & -3 & 0 & 1 \\ \hline \text{New Row 2} & 0 & -5 & 1 & 2 & & \text{New Row 1} & -5 & 0 & 3 & 1 \end{array}$$

The next matrix is  $\left[ \begin{array}{cc|cc} -5 & 0 & 3 & 1 \\ 0 & -5 & 1 & 2 \end{array} \right]$ . We need to divide Row 1 and Row 2 by  $-5$ .

$$\left[ \begin{array}{cc|cc} 1 & 0 & -\frac{3}{5} & -\frac{1}{5} \\ 0 & 1 & -\frac{1}{5} & -\frac{2}{5} \end{array} \right] \text{The inverse matrix is } \begin{bmatrix} -\frac{3}{5} & -\frac{1}{5} \\ -\frac{1}{5} & -\frac{2}{5} \end{bmatrix}.$$

Multiply the inverse matrix by the coefficient matrix.

$$\begin{bmatrix} -\frac{3}{5} & -\frac{1}{5} \\ -\frac{1}{5} & -\frac{2}{5} \end{bmatrix} \cdot \begin{bmatrix} -7 \\ 1 \end{bmatrix} = \begin{bmatrix} -\frac{3}{5} \cdot (-7) + \left(-\frac{1}{5}\right) \cdot 1 \\ -\frac{1}{5} \cdot (-7) + \left(-\frac{2}{5}\right) \cdot 1 \end{bmatrix} = \begin{bmatrix} 4 \\ 1 \end{bmatrix}$$

The solution is  $x = 4$  and  $y = 1$ .

The strategy is the same for a  $3 \times 3$  system of equations.

$$\begin{cases} Ax + By + Cz = J \\ Dx + Ey + Fz = K \\ Gx + Hy + Iz = L \end{cases}$$

The coefficient matrix and the constant matrix are

$$\begin{bmatrix} A & B & C \\ D & E & F \\ G & H & I \end{bmatrix} \text{ and } \begin{bmatrix} J \\ K \\ L \end{bmatrix}.$$

We will find the inverse matrix of the coefficient matrix and multiply it by the constant matrix.

### EXAMPLE

$$\bullet \begin{cases} -3x + 2y + z = 3 \\ 2x + y - z = 5 \\ -y + 2z = -3 \end{cases}$$

The coefficient matrix and constant matrix are

$$\begin{bmatrix} -3 & 2 & 1 \\ 2 & 1 & -1 \\ 0 & -1 & 2 \end{bmatrix} \text{ and } \begin{bmatrix} 3 \\ 5 \\ -3 \end{bmatrix}.$$

$$\left[ \begin{array}{ccc|ccc} -3 & 2 & 1 & 1 & 0 & 0 \\ 2 & 1 & -1 & 0 & 1 & 0 \\ 0 & -1 & 2 & 0 & 0 & 1 \end{array} \right]$$

$$\begin{array}{rcccccc} 2 \text{ Row 1} & -6 & 4 & 2 & 2 & 0 & 0 \\ +3 \text{ Row 2} & 6 & 3 & -3 & 0 & 3 & 0 \\ \hline \text{New Row 2} & 0 & 7 & -1 & 2 & 3 & 0 \end{array}$$

New Row 3 is old Row 3. The next matrix is 
$$\left[ \begin{array}{ccc|ccc} -3 & 2 & 1 & 1 & 0 & 0 \\ 0 & 7 & -1 & 2 & 3 & 0 \\ 0 & -1 & 2 & 0 & 0 & 1 \end{array} \right].$$

$$\begin{array}{r} 7 \text{ Row 1} \quad -21 \quad 14 \quad 7 \quad 7 \quad 0 \quad 0 \\ +(-2) \text{ Row 2} \quad \quad 0 \quad -14 \quad 2 \quad -4 \quad -6 \quad 0 \\ \hline \text{New Row 1} \quad -21 \quad \quad 0 \quad 9 \quad 3 \quad -6 \quad 0 \end{array}$$

$$\begin{array}{r} \text{Row 2} \quad 0 \quad 7 \quad -1 \quad 2 \quad 3 \quad 0 \\ +7 \text{ Row 3} \quad 0 \quad -7 \quad 14 \quad 0 \quad 0 \quad 7 \\ \hline \text{New Row 3} \quad 0 \quad 0 \quad 13 \quad 2 \quad 3 \quad 7 \end{array}$$

The next matrix is 
$$\left[ \begin{array}{ccc|ccc} -21 & 0 & 9 & 3 & -6 & 0 \\ 0 & 7 & -1 & 2 & 3 & 0 \\ 0 & 0 & 13 & 2 & 3 & 7 \end{array} \right].$$

$$\begin{array}{r} 13 \text{ Row 1} \quad -273 \quad 0 \quad 117 \quad 39 \quad -78 \quad 0 \\ +(-9) \text{ Row 3} \quad \quad 0 \quad 0 \quad -117 \quad -18 \quad -27 \quad -63 \\ \hline \text{New Row 1} \quad -273 \quad 0 \quad \quad 0 \quad 21 \quad -105 \quad -63 \end{array}$$

$$\begin{array}{r} 13 \text{ Row 2} \quad 0 \quad 91 \quad -13 \quad 26 \quad 39 \quad 0 \\ + \text{ Row 3} \quad 0 \quad 0 \quad 13 \quad 2 \quad 3 \quad 7 \\ \hline \text{New Row 2} \quad 0 \quad 91 \quad \quad 0 \quad 28 \quad 42 \quad 7 \end{array}$$

The next matrix is 
$$\left[ \begin{array}{ccc|ccc} -273 & 0 & 0 & 21 & -105 & -63 \\ 0 & 91 & 0 & 28 & 42 & 7 \\ 0 & 0 & 13 & 2 & 3 & 7 \end{array} \right].$$

Divide Row 1 by  $-273$ , Row 2 by  $91$ , and Row 3 by  $13$ .

$$\left[ \begin{array}{ccc|ccc} 1 & 0 & 0 & -\frac{1}{13} & \frac{5}{13} & \frac{3}{13} \\ 0 & 1 & 0 & \frac{4}{13} & \frac{6}{13} & \frac{1}{13} \\ 0 & 0 & 1 & \frac{2}{13} & \frac{3}{13} & \frac{7}{13} \end{array} \right]$$

Multiply the inverse matrix by the constant matrix.

$$\begin{bmatrix} -\frac{1}{13} & \frac{5}{13} & \frac{3}{13} \\ \frac{4}{13} & \frac{6}{13} & \frac{1}{13} \\ \frac{2}{13} & \frac{3}{13} & \frac{7}{13} \end{bmatrix} \cdot \begin{bmatrix} 3 \\ 5 \\ -3 \end{bmatrix} = \begin{bmatrix} 3\left(-\frac{1}{13}\right) + 5\left(\frac{5}{13}\right) + (-3)\left(\frac{3}{13}\right) \\ 3\left(\frac{4}{13}\right) + 5\left(\frac{6}{13}\right) + (-3)\left(\frac{1}{13}\right) \\ 3\left(\frac{2}{13}\right) + 5\left(\frac{3}{13}\right) + (-3)\left(\frac{7}{13}\right) \end{bmatrix} = \begin{bmatrix} 1 \\ 3 \\ 0 \end{bmatrix}$$

The solution is  $x = 1$ ,  $y = 3$  and  $z = 0$ .



**PRACTICE**

1. Use the first method to solve the system.

$$\begin{cases} -5x + 2y + 3z = -8 \\ x + y - z = -5 \\ 2x + y + 3z = 23 \end{cases}$$

2. Use the first method to solve the system.

$$\begin{cases} 6x + 2z = -12 \\ x - y = -3 \\ y + z = 1 \end{cases}$$

3. Use the second method to solve the system.

$$\begin{cases} x + z = 6 \\ 3x - y + 2z = 17 \\ 6x + y - z = 5 \end{cases}$$

**SOLUTIONS**

1. The augmented matrix is  $\left[ \begin{array}{ccc|c} -5 & 2 & 3 & -8 \\ 1 & 1 & -1 & -5 \\ 2 & 1 & 3 & 23 \end{array} \right]$ .

$$\begin{array}{r} \text{Row 1} \quad -5 \quad 2 \quad 3 \quad -8 \quad \quad \quad 2 \text{ Row 1} \quad -10 \quad 4 \quad 6 \quad -16 \\ +5 \text{ Row 2} \quad 5 \quad 5 \quad -5 \quad -25 \quad \quad \quad +5 \text{ Row 3} \quad 10 \quad 5 \quad 15 \quad 115 \\ \hline \text{New Row 2} \quad 0 \quad 7 \quad -2 \quad -33 \quad \quad \quad \text{New Row 3} \quad 0 \quad 9 \quad 21 \quad 99 \end{array}$$

The next matrix is  $\left[ \begin{array}{ccc|c} -5 & 2 & 3 & -8 \\ 0 & 7 & -2 & -33 \\ 0 & 9 & 21 & 99 \end{array} \right]$ .

$$\begin{array}{r} 7 \text{ Row 1} \quad -35 \quad 14 \quad 21 \quad -56 \quad \quad \quad 9 \text{ Row 2} \quad 0 \quad 63 \quad -18 \quad -297 \\ +(-2) \text{ Row 2} \quad 0 \quad -14 \quad 4 \quad 66 \quad \quad \quad +(-7) \text{ Row 3} \quad 0 \quad -63 \quad -147 \quad -693 \\ \hline \text{New Row 1} \quad -35 \quad 0 \quad 25 \quad 10 \quad \quad \quad \text{New Row 3} \quad 0 \quad 0 \quad -165 \quad -990 \end{array}$$

The next matrix is  $\left[ \begin{array}{ccc|c} -35 & 0 & 25 & 10 \\ 0 & 7 & -2 & -33 \\ 0 & 0 & -165 & -990 \end{array} \right]$ .

We can make the numbers in Row 1 and Row 3 smaller by dividing Row 1 by 5 and Row 3 by  $-165$ .

$$\left[ \begin{array}{ccc|c} -7 & 0 & 5 & 2 \\ 0 & 7 & -2 & -33 \\ 0 & 0 & 1 & 6 \end{array} \right]$$

$$\begin{array}{rcccl} \text{Row 1} & -7 & 0 & 5 & 2 & & \text{Row 2} & 0 & 7 & -2 & -33 \\ +(-5) \text{ Row 3} & & & -5 & -30 & & +2 \text{ Row 3} & & & 2 & 12 \\ \hline \text{New Row 1} & -7 & 0 & 0 & -28 & & \text{New Row 2} & 0 & 7 & 0 & -21 \end{array}$$

The next matrix is

$$\left[ \begin{array}{ccc|c} -7 & 0 & 0 & -28 \\ 0 & 7 & 0 & -21 \\ 0 & 0 & 1 & 6 \end{array} \right].$$

Divide Row 1 by  $-7$  and Row 2 by  $7$ .

$$\left[ \begin{array}{ccc|c} 1 & 0 & 0 & 4 \\ 0 & 1 & 0 & -3 \\ 0 & 0 & 1 & 6 \end{array} \right]$$

The solution is  $x = 4$ ,  $y = -3$ , and  $z = 6$ .

2. The augmented matrix is  $\left[ \begin{array}{ccc|c} 6 & 0 & 2 & -12 \\ 1 & -1 & 0 & -3 \\ 0 & 1 & 1 & 1 \end{array} \right]$ .

$$\begin{array}{rcccl} \text{Row 1} & 6 & 0 & 2 & -12 \\ +(-6) \text{ Row 2} & -6 & 6 & 0 & 18 \\ \hline \text{New Row 2} & 0 & 6 & 2 & 6 \end{array}$$

New Row 3 is old Row 3. The next matrix is  $\left[ \begin{array}{ccc|c} 6 & 0 & 2 & -12 \\ 0 & 6 & 2 & 6 \\ 0 & 1 & 1 & 1 \end{array} \right]$ .

$$\begin{array}{rcccl} \text{Row 2} & 0 & 6 & 2 & 6 \\ +(-6) \text{ Row 3} & 0 & -6 & -6 & -6 \\ \hline \text{New Row 3} & 0 & 0 & -4 & 0 \end{array}$$

New Row 1 is old Row 1. The next matrix is  $\begin{bmatrix} 6 & 0 & 2 & | & -12 \\ 0 & 6 & 2 & | & 6 \\ 0 & 0 & -4 & | & 0 \end{bmatrix}$ .

$$\begin{array}{r} \text{Row 1} \quad 6 \quad 0 \quad 2 \quad -12 \\ +\frac{1}{2} \text{ Row 3} \quad 0 \quad 0 \quad -2 \quad 0 \\ \hline \text{New Row 1} \quad 6 \quad 0 \quad 0 \quad -12 \end{array} \qquad \begin{array}{r} \text{New Row 2} \quad 0 \quad 6 \quad 2 \quad 6 \\ +\frac{1}{2} \text{ Row 3} \quad 0 \quad 0 \quad -2 \quad 0 \\ \hline \text{New Row 2} \quad 0 \quad 6 \quad 0 \quad 6 \end{array}$$

The next matrix is  $\begin{bmatrix} 6 & 0 & 0 & | & -12 \\ 0 & 6 & 0 & | & 6 \\ 0 & 0 & -4 & | & 0 \end{bmatrix}$ . Divide Row 1 and Row 2 by 6 and Row 3 by  $-4$ .

$$\begin{bmatrix} 1 & 0 & 0 & | & -2 \\ 0 & 1 & 0 & | & 1 \\ 0 & 0 & 1 & | & 0 \end{bmatrix} \text{ The solution is } x = -2, y = 1, \text{ and } z = 0.$$

3. The augmented matrix is

$$\begin{bmatrix} 1 & 0 & 1 & | & 1 & 0 & 0 \\ 3 & -1 & 2 & | & 0 & 1 & 0 \\ 6 & 1 & -1 & | & 0 & 0 & 1 \end{bmatrix}.$$

$$\begin{array}{r} -3 \text{ Row 1} \quad -3 \quad 0 \quad -3 \quad -3 \quad 0 \quad 0 \\ + \text{ Row 2} \quad 3 \quad -1 \quad 2 \quad 0 \quad 1 \quad 0 \\ \hline \text{New Row 2} \quad 0 \quad -1 \quad -1 \quad -3 \quad 1 \quad 0 \end{array} \qquad \begin{array}{r} -6 \text{ Row 1} \quad -6 \quad 0 \quad -6 \quad -6 \quad 0 \quad 0 \\ + \text{ Row 3} \quad 6 \quad 1 \quad -1 \quad 0 \quad 0 \quad 1 \\ \hline \text{New Row 3} \quad 0 \quad 1 \quad -7 \quad -6 \quad 0 \quad 1 \end{array}$$

The next matrix is

$$\begin{bmatrix} 1 & 0 & 1 & | & 1 & 0 & 0 \\ 0 & -1 & -1 & | & -3 & 1 & 0 \\ 0 & 1 & -7 & | & -6 & 0 & 1 \end{bmatrix}.$$

$$\begin{array}{r} \text{Row 2} \quad 0 \quad -1 \quad -1 \quad -3 \quad 1 \quad 0 \\ + \text{ Row 3} \quad 0 \quad 1 \quad -7 \quad -6 \quad 0 \quad 1 \\ \hline \text{New Row 3} \quad 0 \quad 0 \quad -8 \quad -9 \quad 1 \quad 1 \end{array}$$

New Row 1 is old Row 1. The next matrix is

$$\begin{bmatrix} 1 & 0 & 1 & | & 1 & 0 & 0 \\ 0 & -1 & -1 & | & -3 & 1 & 0 \\ 0 & 0 & -8 & | & -9 & 1 & 1 \end{bmatrix}.$$



$$\begin{array}{r}
 8 \text{ Row 1} \quad 8 \quad 0 \quad 8 \quad 8 \quad 0 \quad 0 \\
 + \text{ Row 3} \quad 0 \quad 0 \quad -8 \quad -9 \quad 1 \quad 1 \\
 \hline
 \text{New Row 1} \quad 8 \quad 0 \quad 0 \quad -1 \quad 1 \quad 1 \\
 \\
 -8 \text{ Row 2} \quad 0 \quad 8 \quad 8 \quad 24 \quad -8 \quad 0 \\
 + \text{ Row 3} \quad 0 \quad 0 \quad -8 \quad -9 \quad 1 \quad 1 \\
 \hline
 \text{New Row 2} \quad 0 \quad 8 \quad 0 \quad 15 \quad -7 \quad 1
 \end{array}$$

The next matrix is 
$$\left[ \begin{array}{ccc|ccc} 8 & 0 & 0 & -1 & 1 & 1 \\ 0 & 8 & 0 & 15 & -7 & 1 \\ 0 & 0 & -8 & -9 & 1 & 1 \end{array} \right].$$

Divide Row 1 and Row 2 by 8 and Row 3 by  $-8$ .

$$\left[ \begin{array}{ccc|ccc} 1 & 0 & 0 & -\frac{1}{8} & \frac{1}{8} & \frac{1}{8} \\ 0 & 1 & 0 & \frac{15}{8} & -\frac{7}{8} & \frac{1}{8} \\ 0 & 0 & 1 & \frac{9}{8} & -\frac{1}{8} & -\frac{1}{8} \end{array} \right]$$

The inverse matrix is

$$\left[ \begin{array}{ccc} -\frac{1}{8} & \frac{1}{8} & \frac{1}{8} \\ \frac{15}{8} & -\frac{7}{8} & \frac{1}{8} \\ \frac{9}{8} & -\frac{1}{8} & -\frac{1}{8} \end{array} \right].$$

Multiply the inverse matrix, by the coefficient matrix  $\begin{bmatrix} 6 \\ 17 \\ 5 \end{bmatrix}$ .

$$\left[ \begin{array}{ccc} -\frac{1}{8} & \frac{1}{8} & \frac{1}{8} \\ \frac{15}{8} & -\frac{7}{8} & \frac{1}{8} \\ \frac{9}{8} & -\frac{1}{8} & -\frac{1}{8} \end{array} \right] \cdot \begin{bmatrix} 6 \\ 17 \\ 5 \end{bmatrix} = \begin{bmatrix} 6\left(-\frac{1}{8}\right) + 17\left(\frac{1}{8}\right) + 5\left(\frac{1}{8}\right) \\ 6\left(\frac{15}{8}\right) + 17\left(-\frac{7}{8}\right) + 5\left(\frac{1}{8}\right) \\ 6\left(\frac{9}{8}\right) + 17\left(-\frac{1}{8}\right) + 5\left(-\frac{1}{8}\right) \end{bmatrix} = \begin{bmatrix} 2 \\ -3 \\ 4 \end{bmatrix}$$

The solution is  $x = 2$ ,  $y = -3$  and  $z = 4$

The last computation we will learn is finding a matrix's *determinant*. Although we will not use the determinant here, it is used in vector mathematics courses, some theoretical algebra courses, and in algebra courses that cover Cramer's Rule (used to solve systems of linear equations). An interesting fact about determinants is that a square matrix has an inverse only when its determinant is a nonzero number.

The usual notation for a determinant is to enclose the matrix using two vertical bars instead of two brackets. The determinant for the matrix  $\begin{bmatrix} A & B \\ C & D \end{bmatrix}$  is  $\begin{vmatrix} A & B \\ C & D \end{vmatrix}$ .

Finding the determinant for a  $2 \times 2$  matrix is not hard.

$$\begin{vmatrix} A & B \\ C & D \end{vmatrix} = AD - BC$$

### EXAMPLE

- $\begin{vmatrix} 4 & -3 \\ 5 & 2 \end{vmatrix} = 4(2) - (-3)(5) = 23$

We find the determinant of larger matrices by breaking down the larger matrix into several  $2 \times 2$  sub-matrices. For larger matrices, there are numerous formulas for computing their determinants. Some of them come from *expanding the matrix* along each row and along each column. This means that we will multiply the entries in a row or a column by the determinant of a smaller matrix. This smaller matrix comes from deleting the row and column an entry is in. When working with a  $3 \times 3$  matrix, these sub-matrices will be  $2 \times 2$  matrices.

Suppose we want to expand the following matrix along the first row.

$$\begin{bmatrix} A & B & C \\ D & E & F \\ G & H & I \end{bmatrix}$$

We will multiply the  $A$  entry by the submatrix obtained by removing the first row  $ABC$  and the first column  $\begin{smallmatrix} A \\ D \\ G \end{smallmatrix}$ . This leaves us with the matrix

$$\begin{bmatrix} - & - & - \\ - & E & F \\ - & H & I \end{bmatrix}. \text{ Our first calculation will be}$$

$$A \begin{vmatrix} E & F \\ H & I \end{vmatrix} = A(EI - FH).$$

Similarly, when we use entry  $B$ , we will need to remove the first row  $ABC$  and the second column  $\begin{smallmatrix} B \\ E \\ H \end{smallmatrix}$ . This leaves us with  $\begin{vmatrix} D & F \\ G & I \end{vmatrix}$ . There is a complication—the signs on the entries must alternate when we perform these expansions. For our matrix, the signs will alternate beginning with  $A$  not changing, but  $B$  and  $D$  changing.

$$\begin{array}{ccc} A & -B & C \\ -D & E & -F \\ G & -H & J \end{array}$$

For our  $3 \times 3$  matrix, the expansion along the first row looks like this.

$$A \begin{vmatrix} E & F \\ H & I \end{vmatrix} - B \begin{vmatrix} D & F \\ G & I \end{vmatrix} + C \begin{vmatrix} D & E \\ G & H \end{vmatrix} = A(EI - FH) - B(DI - FG) \\ + C(DH - EG)$$

The expansion along the second column looks like this.

$$-B \begin{vmatrix} D & F \\ G & I \end{vmatrix} + E \begin{vmatrix} A & C \\ G & I \end{vmatrix} - H \begin{vmatrix} A & C \\ D & F \end{vmatrix} = -B(DI - FG) + E(AI - CG) \\ - H(AF - CD)$$

### EXAMPLE

- Find the determinant for  $\begin{bmatrix} 4 & 1 & -3 \\ 2 & 0 & 4 \\ -2 & 2 & 1 \end{bmatrix}$ .

We will use two calculations, along Row 2 and along Column 3. By Row 2 we have

$$-2 \begin{vmatrix} 1 & -3 \\ 2 & 1 \end{vmatrix} + 0 \begin{vmatrix} 4 & -3 \\ -2 & 1 \end{vmatrix} - 4 \begin{vmatrix} 4 & 1 \\ -2 & 2 \end{vmatrix} \\ = -2(1 \cdot 1 - (-3)2) + 0(4 \cdot 1 - (-3)(-2)) - 4(4 \cdot 2 - 1(-2)) = -54.$$

By Column 3 we have

$$-3 \begin{vmatrix} 2 & 0 \\ -2 & 2 \end{vmatrix} - 4 \begin{vmatrix} 4 & 1 \\ -2 & 2 \end{vmatrix} + 1 \begin{vmatrix} 4 & 1 \\ 2 & 0 \end{vmatrix} \\ = -3(2 \cdot 2 - 0(-2)) - 4(4 \cdot 2 - 1(-2)) + 1(4 \cdot 0 - 1 \cdot 2) = -54$$

The method is the same for larger matrices except that there are more levels of work.

$$\begin{bmatrix} A & B & C & D \\ E & F & G & H \\ I & J & K & L \\ M & N & O & P \end{bmatrix}$$

Expanding this matrix along Row 1 gives us

$$A \begin{vmatrix} F & G & H \\ J & K & L \\ N & O & P \end{vmatrix} - B \begin{vmatrix} E & G & H \\ I & K & L \\ M & O & P \end{vmatrix} + C \begin{vmatrix} E & F & H \\ I & J & L \\ M & N & P \end{vmatrix} - D \begin{vmatrix} E & F & G \\ I & J & K \\ M & N & O \end{vmatrix}.$$

Each of these four determinants must be computed using the previous method for a  $3 \times 3$  matrix.

## PRACTICE

1. 
$$\begin{bmatrix} -8 & 1 & 3 \\ 2 & 5 & 0 \\ 6 & -4 & 2 \end{bmatrix}$$

## SOLUTION

1. Expanding this matrix along Row 2, we have

$$-2 \begin{vmatrix} 1 & 3 \\ -4 & 2 \end{vmatrix} + 5 \begin{vmatrix} -8 & 3 \\ 6 & 2 \end{vmatrix} - 0 \begin{vmatrix} -8 & 1 \\ 6 & -4 \end{vmatrix}$$

$$= -2(1 \cdot 2 - 3(-4)) + 5(-8 \cdot 2 - 3 \cdot 6) - 0((-8)(-4) - 1 \cdot 6) = -198$$

## CHAPTER 11 REVIEW

1. 
$$\begin{bmatrix} 8 & 4 \\ -1 & -5 \end{bmatrix} - \begin{bmatrix} 3 & -1 \\ -2 & 6 \end{bmatrix} =$$

(a) 
$$\begin{bmatrix} 5 & 3 \\ -3 & 1 \end{bmatrix}$$

(b) 
$$\begin{bmatrix} 11 & 3 \\ -3 & 1 \end{bmatrix}$$

(c) 
$$\begin{bmatrix} 5 & 5 \\ -1 & 1 \end{bmatrix}$$

(d) 
$$\begin{bmatrix} 5 & 5 \\ 1 & -11 \end{bmatrix}$$

2. 
$$\begin{bmatrix} 7 & 4 \\ 1 & 1 \end{bmatrix} \cdot \begin{bmatrix} 0 & -2 \\ 3 & 1 \end{bmatrix} =$$

(a) 
$$\begin{bmatrix} 0 & -8 \\ 3 & 1 \end{bmatrix}$$

(b) 
$$\begin{bmatrix} 12 & -10 \\ 3 & -1 \end{bmatrix}$$

(c) 
$$\begin{bmatrix} 8 & -10 \\ 4 & 2 \end{bmatrix}$$

(d) 
$$\begin{bmatrix} 0 & -10 \\ 4 & -1 \end{bmatrix}$$

3.  $\begin{bmatrix} -1 & 4 \\ 0 & 2 \end{bmatrix} \cdot \begin{bmatrix} 1 & 1 & -1 \\ 2 & -1 & 3 \end{bmatrix} =$
- (a)  $\begin{bmatrix} 7 & 4 & -2 \\ 2 & 2 & -2 \end{bmatrix}$  (b)  $\begin{bmatrix} 7 & 2 \\ 4 & 2 \\ -2 & -2 \end{bmatrix}$
- (c)  $\begin{bmatrix} 7 & -5 & 13 \\ 4 & -2 & 6 \end{bmatrix}$  (d) The product does not exist.
4. What is the determinant for  $\begin{bmatrix} -8 & 1 \\ 4 & 5 \end{bmatrix}$ ?
- (a)  $-36$  (b)  $-37$  (c)  $-44$  (d)  $-27$
5. What is the inverse for  $\begin{bmatrix} 2 & -3 \\ -1 & 1 \end{bmatrix}$ ?
- (a)  $\begin{bmatrix} \frac{1}{2} & -\frac{1}{3} \\ -1 & 1 \end{bmatrix}$  (b)  $\begin{bmatrix} -1 & -3 \\ -1 & -2 \end{bmatrix}$
- (c)  $\begin{bmatrix} \frac{1}{5} & -\frac{4}{5} \\ \frac{1}{2} & 2 \end{bmatrix}$  (d)  $\begin{bmatrix} -1 & 1 \\ 2 & -3 \end{bmatrix}$
6. What is the determinant for  $\begin{bmatrix} 6 & 0 & 2 \\ 1 & -1 & 0 \\ 0 & 1 & 1 \end{bmatrix}$ ?
- (a)  $-4$  (b)  $-5$  (c)  $-6$  (d)  $-7$
7. What is the inverse for  $\begin{bmatrix} 1 & 0 & 3 \\ -1 & 1 & -1 \\ 2 & 1 & 0 \end{bmatrix}$ ?
- (a)  $\begin{bmatrix} -\frac{1}{8} & -\frac{3}{8} & \frac{3}{8} \\ \frac{1}{4} & \frac{3}{4} & \frac{1}{4} \\ \frac{3}{8} & \frac{1}{8} & -\frac{1}{8} \end{bmatrix}$  (b)  $\begin{bmatrix} \frac{1}{4} & \frac{3}{4} & \frac{1}{4} \\ \frac{3}{8} & \frac{1}{8} & -\frac{1}{8} \\ -\frac{1}{8} & -\frac{3}{8} & \frac{3}{8} \end{bmatrix}$
- (c)  $\begin{bmatrix} \frac{3}{8} & \frac{1}{8} & -\frac{1}{8} \\ -\frac{1}{8} & -\frac{3}{8} & \frac{3}{8} \\ \frac{1}{4} & \frac{3}{4} & \frac{1}{4} \end{bmatrix}$  (d)  $\begin{bmatrix} \frac{1}{8} & \frac{3}{8} & -\frac{1}{8} \\ -\frac{3}{8} & -\frac{1}{8} & \frac{3}{8} \\ \frac{3}{4} & \frac{1}{4} & \frac{1}{4} \end{bmatrix}$

For Problems 8–10, use different matrix methods to solve the systems.

8. What is  $x + y$  for the system?

$$\begin{cases} 5x - 8y = 29 \\ 2x + 2y = -4 \end{cases}$$

- (a)  $-2$             (b)  $-3$             (c)  $-4$             (d)  $-5$

9. What is  $x + y + z$  for the system?

$$\begin{cases} x + y + z = 1 \\ 2x - y + z = 3 \\ -x + y - 3z = -7 \end{cases}$$

- (a)  $0$             (b)  $1$             (c)  $2$             (d)  $3$

10. What is  $x + y + z$  for the system?

$$\begin{cases} 6x + \quad -z = -22 \\ x + y - z = -6 \\ \quad y + z = 5 \end{cases}$$

- (a)  $-1$             (b)  $-2$             (c)  $1$             (d)  $2$

## SOLUTIONS

1. D      2. B      3. C      4. C      5. B  
6. A      7. A      8. A      9. B      10. D

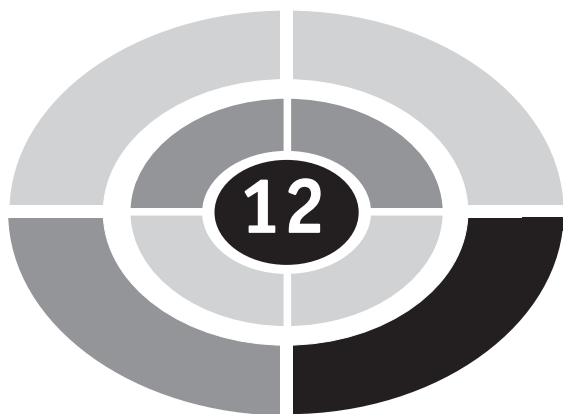

## CHAPTER

# Conic Sections

A *conic section* is a shape obtained when a cone is sliced. The study of conic sections began over two thousand years ago and we use their properties today. Planets in our solar system move around the sun in elliptical orbits. The cross-section of many reflecting surfaces is in the shape of a parabola. In fact, all of the conic sections have useful reflecting properties. There are three conic sections—parabolas, ellipses (including circles), and hyperbolas.

## Parabolas

In Chapter 6, we learned how to graph parabolas when their equations were in the form  $y = a(x - h)^2 + k$  or  $y = ax^2 + bx + c$ . Now we will learn the formal definition for a parabola and another form for its equation.

**DEFINITION:** A parabola is the set of all points whose distance to a fixed point and a fixed line are the same.

The fixed point is the *focus*. The fixed line is the *directrix*. For example, the focus for the parabola  $y = -\frac{1}{2}x^2 - 3x + 2$  is  $(-3, 6)$ , and the directrix is the horizontal line  $y = 7$ . The point  $(0, 2)$  is on the parabola. Its distance from the line  $y = 7$  is 5.

Its distance from the focus  $(-3, 6)$  is also 5.

$$\sqrt{(-3 - 0)^2 + (6 - 2)^2} = \sqrt{25} = 5$$

The new form for a parabola that opens up or down is  $(x - h)^2 = 4p(y - k)$ . The vertex is still at  $(h, k)$ , but  $p$  helps us to find the focus and the equation for the directrix. The focus is the point  $(h, k + p)$ , and the directrix is the horizontal line  $y = k - p$ . The form for the equation for a parabola that opens to the side is  $(y - k)^2 = 4p(x - h)$ . The focus for a parabola that opens to the right or to the left is the point  $(h + p, k)$ , and the directrix is the vertical line  $x = h - p$ . This information is summarized in Table 12.1 and in Figures 12.1 and 12.2.

Table 12.1

$(x - h)^2 = 4p(y - k)$	$(y - k)^2 = 4p(x - h)$
The vertex is $(h, k)$ .	The vertex is $(h, k)$ .
The parabola opens up if $p$ is positive and down if $p$ is negative.	The parabola opens to the right if $p$ is positive and to the left if $p$ is negative.
The focus is $(h, k + p)$ .	The focus is $(h + p, k)$ .
The directrix is $y = k - p$ .	The directrix is $x = h - p$ .
The axis of symmetry is $x = h$ .	The axis of symmetry is $y = k$ .

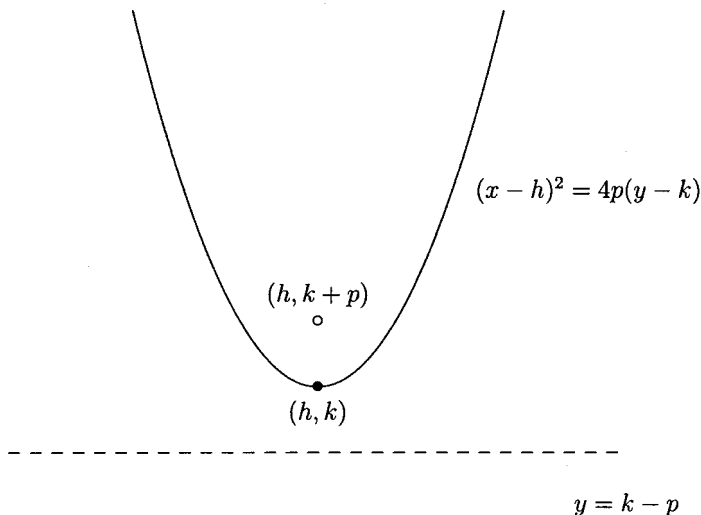

Fig. 12.1.



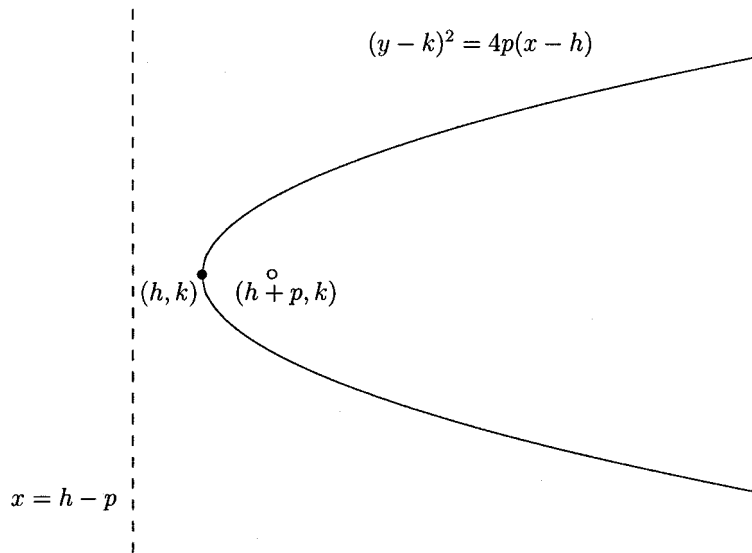

Fig. 12.2.

In the following examples, we will be asked to match the equation to its graph. The vertex for each parabola will be at  $(0, 0)$ . We can decide which graph goes to which equation either by finding the focus or the directrix in the equation and finding which graph has this focus or directrix.

**EXAMPLES**

Match the graphs in Figures 12.3 through 12.6 with their equations.

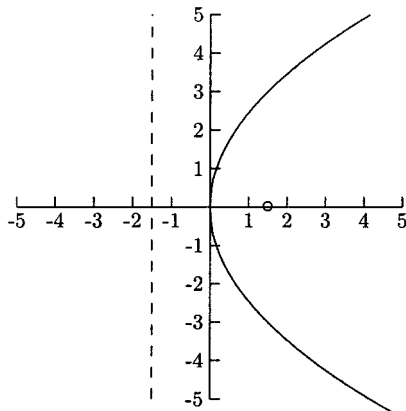

Fig. 12.3.

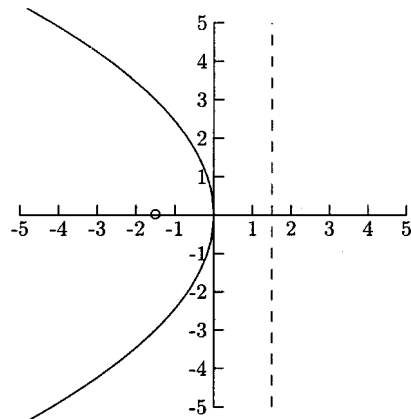

Fig. 12.4.

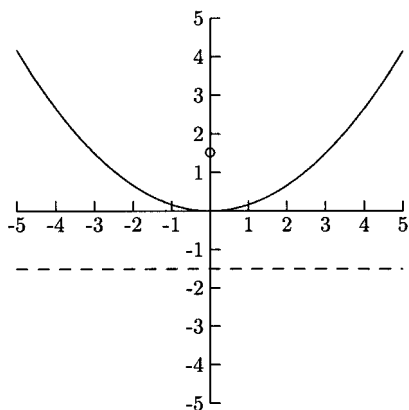

Fig. 12.5.

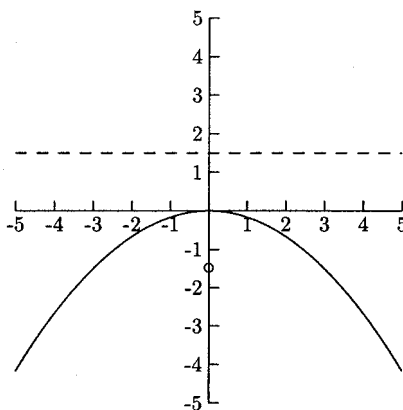

Fig. 12.6.

- $x^2 = 6y$

The equation is in the form  $(x - h)^2 = 4p(y - k)$ , so the parabola will open up or down. We have  $p = \frac{3}{2}$  (from  $6 = 4p$ ). Now we know three things—that the parabola opens up (because  $p$  is positive), that the focus is  $(h, k + p) = (0, 0 + \frac{3}{2}) = (0, \frac{3}{2})$ , and the directrix is  $y = -\frac{3}{2}$  (from  $k - p = 0 - \frac{3}{2}$ ). The graph that behaves this way is in Figure 12.5.

- $y^2 = 6x$

The equation is in the form  $(y - k)^2 = 4p(x - h)$ , so the parabola opens to the left or to the right. We have  $p = \frac{3}{2}$  (from  $6 = 4p$ ). Now we know that the parabola opens to the right, that the focus is  $(h + p, k) = (0 + \frac{3}{2}, 0) = (\frac{3}{2}, 0)$ , and that the directrix is  $x = -\frac{3}{2}$  (from  $h - p = 0 - \frac{3}{2}$ ). The graph for this equation is in Figure 12.3.

- $y^2 = -6x$

The equation is in the form  $(y - k)^2 = 4p(x - h)$ , so the parabola opens to the left or to the right. We have  $p = -\frac{3}{2}$  (from  $-6 = 4p$ ). The parabola opens to the left, the focus is  $(h + p, k) = (0 + -\frac{3}{2}, 0) = (-\frac{3}{2}, 0)$ , and the directrix is  $x = \frac{3}{2}$  (from  $h - p = 0 - (-\frac{3}{2})$ ). The graph for this equation is in Figure 12.4.

- $x^2 = -6y$

The equation is in the form  $(x - h)^2 = 4p(y - k)$ , so the parabola opens up or down. We have  $p = -\frac{3}{2}$  (from  $-6 = 4p$ ). The parabola opens down, the focus is  $(h, k + p) = (0, 0 + (-\frac{3}{2})) = (0, -\frac{3}{2})$ . The directrix is  $y = \frac{3}{2}$  (from  $k - p = 0 - (-\frac{3}{2})$ ). The graph for this equation is in Figure 12.6.

Using the information in Table 12.1, we can find the vertex, focus, directrix, and whether the parabola opens up, down, to the left, or to the right by looking at its equation.

## EXAMPLES

Find the vertex, focus, and directrix. Determine if the parabola opens up, down, to the left, or to the right.

- $(x - 3)^2 = 4(y - 2)$

This equation is in the form  $(x - h)^2 = 4p(y - k)$ . The vertex is  $(3, 2)$ . Once we have found  $p$ , we can find the focus and directrix and how the parabola opens.  $p = 1$  (from  $4 = 4p$ ). The parabola opens up because  $p$  is positive; the focus is  $(h, k + p) = (3, 2 + 1) = (3, 3)$ ; and the directrix is  $y = 1$  (from  $y = k - p = 2 - 1 = 1$ ).

- $(y + 1)^2 = 8(x - 3)$

The equation is in the form  $(y - k)^2 = 4p(x - h)$ . The vertex is  $(3, -1)$ ,  $p = 2$  (from  $8 = 4p$ ); the parabola opens to the right; the focus is  $(h + p, k) = (3 + 2, -1) = (5, -1)$ ; and the directrix is  $x = 1$  (from  $x = h - p = 3 - 2 = 1$ ).

If we know any two of the vertex, focus, and directrix, we can find an equation of the parabola. From the information given, we first need to decide which form to use. Knowing the directrix is the fastest way to decide this. If the directrix is a horizontal line ( $y = \text{number}$ ), then the equation is  $(x - h)^2 = 4p(y - k)$ . If the directrix is a vertical line ( $x = \text{number}$ ), then the equation is  $(y - k)^2 = 4p(x - h)$ . If we do not have the directrix, we need to look at the coordinates of the vertex and focus. Either both the  $x$ -coordinates will be the same or both  $y$ -coordinates will be. If both  $x$ -coordinates are the same, the parabola opens up or down. We need to use the form  $(x - h)^2 = 4p(y - k)$ . If both  $y$ -coordinates are the same, the parabola opens to the side. We need to use the form  $(y - k)^2 = 4p(x - h)$ . Once we have decided which form to use, we might need to use algebra to find  $h$ ,  $k$ , and  $p$ . For example, if we know the focus is  $(2, -1)$  and the directrix is  $x = 6$ , then we know  $h - p = 6$  and  $h + p = 2$  and  $k = -1$ . The equations  $h - p = 6$  and  $h + p = 2$  form a system of equations.

$$h - p = 6$$

$$\underline{h + p = 2}$$

$$2h = 8$$

$$h = 4$$

$$4 - p = 6 \quad \text{Let } h = 4 \text{ in } h - p = 6$$

$$p = -2$$

Now that we have all three numbers and the form, we are ready to write the equation:  $(y + 1)^2 = -8(x - 4)$ .

### EXAMPLES

Find an equation for the parabola.

- The directrix is  $y = 2$ , and the vertex is  $(3, 1)$ .  
Because the directrix is a horizontal line, the equation we want is  $(x - h)^2 = 4p(y - k)$ . The vertex is  $(3, 1)$ , giving us  $h = 3$  and  $k = 1$ . From  $y = k - p$  and  $y = 2$ , we have  $1 - p = 2$ , making  $p = -1$ . The equation is  $(x - 3)^2 = -4(y - 1)$ .
- The focus is  $(4, -2)$ , and the vertex is  $(0, -2)$ .  
The  $y$ -coordinates are the same, so this parabola opens to the side, and the equation we need is  $(y - k)^2 = 4p(x - h)$ . The vertex is  $(h, k) = (0, -2)$ , giving us  $h = 0$  and  $k = -2$ . The focus is  $(h + p, k) = (4, -2)$ . From this we have  $h + p = 0 + p = 4$ , making  $p = 4$ . The equation is  $(y + 2)^2 = 16x$ .
- 

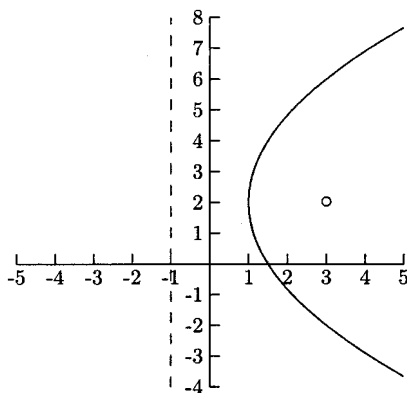

Fig. 12.7.

The directrix is the vertical line  $x = -1$ , and the focus is  $(3, 2)$ . Because the parabola opens to the right, the form we need is  $(y - k)^2 = 4p(x - h)$ .

From the focus we have  $(h + p, k) = (3, 2)$ , so  $h + p = 3$  and  $k = 2$ . The directrix is  $x = -1$  and  $x = h - p$  so  $h - p = -1$ .

$$h - p = -1$$

$$\underline{h + p = 3}$$

$$2h = 2$$

$$h = 1$$

$$1 + p = 3 \quad \text{Let } h = 1 \text{ in } h + p = 3$$

$$p = 2$$

The equation is  $(y - 2)^2 = 8(x - 1)$ .

## PRACTICE

1. Identify the vertex, focus, and directrix for  $(y - 5)^2 = 10(x - 1)$ .
2. Identify the vertex, focus, and directrix for  $(x + 6)^2 = -\frac{1}{2}(y - 4)$ .
3. Find an equation for the parabola that has directrix  $y = -2$  and focus  $(4, 10)$ .

For Problems 4–6, match the equation with its graph in Figures 12.8–12.10.

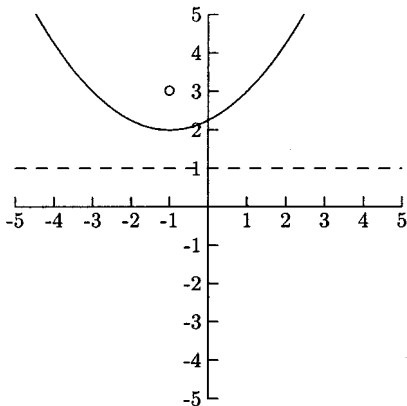

Fig. 12.8.

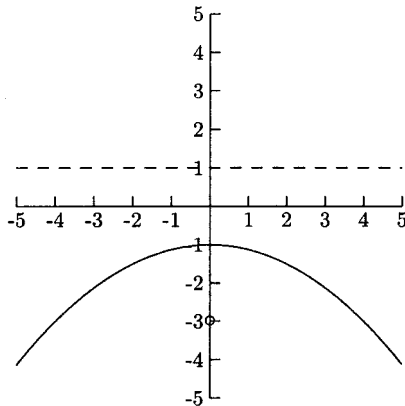

Fig. 12.9.

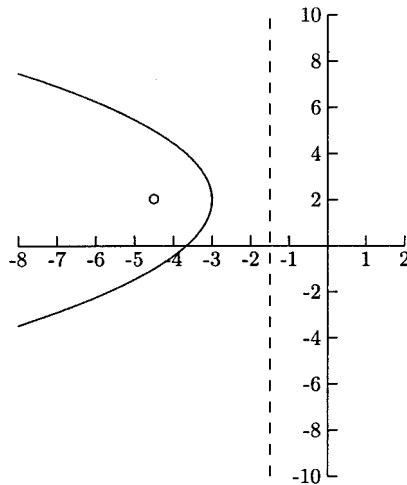

Fig. 12.10.

4.  $x^2 = -8(y + 1)$
5.  $(x + 1)^2 = 4(y - 2)$
6.  $(y - 2)^2 = -6(x + 3)$

## SOLUTIONS

1.  $h = 1$ ,  $k = 5$ , and  $p = \frac{5}{2}$  (from  $4p = 10$ ). The vertex is  $(1, 5)$ ; the focus is  $(h + p, k) = (1 + \frac{5}{2}, 5) = (\frac{7}{2}, 5)$  and the directrix is  $x = -\frac{3}{2}$  (from  $h - p = 1 - \frac{5}{2}$ ).
2.  $h = -6$ ,  $k = 4$ , and  $p = -\frac{1}{8}$  (from  $4p = -\frac{1}{2}$ ). The vertex is  $(-6, 4)$ ; the focus is  $(h, k + p) = (-6, 4 + (-\frac{1}{8})) = (-6, \frac{31}{8})$ ; and the directrix is  $y = \frac{33}{8}$  (from  $k - p = 4 - (-\frac{1}{8})$ ).
3. We want to use the equation  $(x - h)^2 = 4p(y - k)$ . The focus is  $(h, k + p)$ , so  $h = 4$  and  $k + p = 10$ . The directrix is  $y = k - p$ , so  $k - p = -2$ .

$$k + p = 10$$

$$\underline{k - p = -2}$$

$$2k = 8$$

$$k = 4$$

$$4 + p = 10 \quad \text{Let } k = 4 \text{ in } k + p = 10$$

$$p = 6$$

The equation is  $(x - 4)^2 = 24(y - 4)$ .

4. Figure 12.9
5. Figure 12.8
6. Figure 12.10

## Ellipses

Most ellipses look like flattened circles. Usually one diameter is longer than the other. In Figure 12.11, the horizontal diameter is longer than the vertical diameter. In Figure 12.12 the vertical diameter is longer than the horizontal diameter. The longer diameter is the *major axis*, and the shorter diameter is the *minor axis*. An ellipse has seven important points—the center, two endpoints of the major axis (the vertices), two endpoints of the minor axis, and two points along the major axis called the *foci* (plural for *focus*). When the equation of an ellipse is in the form

$$\frac{(x - h)^2}{a^2} + \frac{(y - k)^2}{b^2} = 1 \text{ or } \frac{(x - h)^2}{b^2} + \frac{(y - k)^2}{a^2} = 1,$$

we can find these points without much trouble.

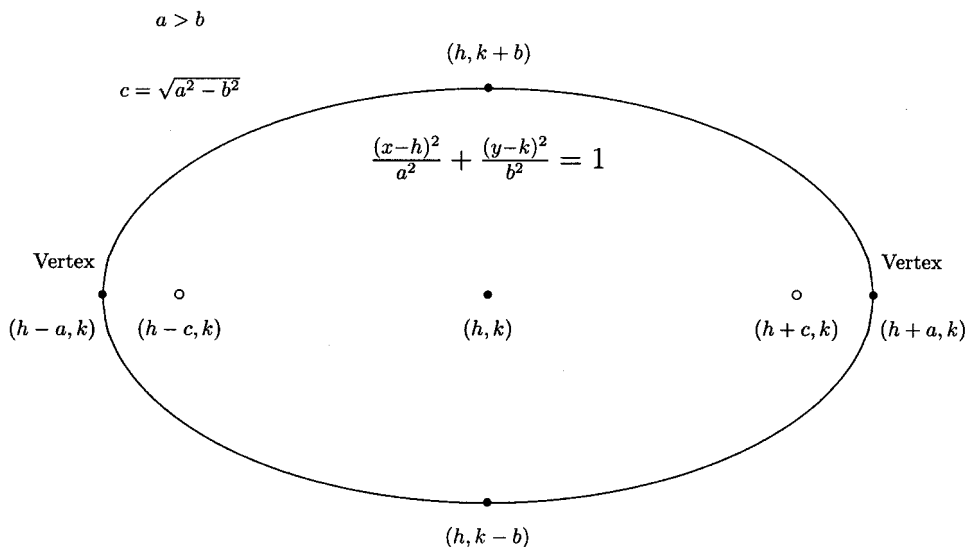

Fig. 12.11.

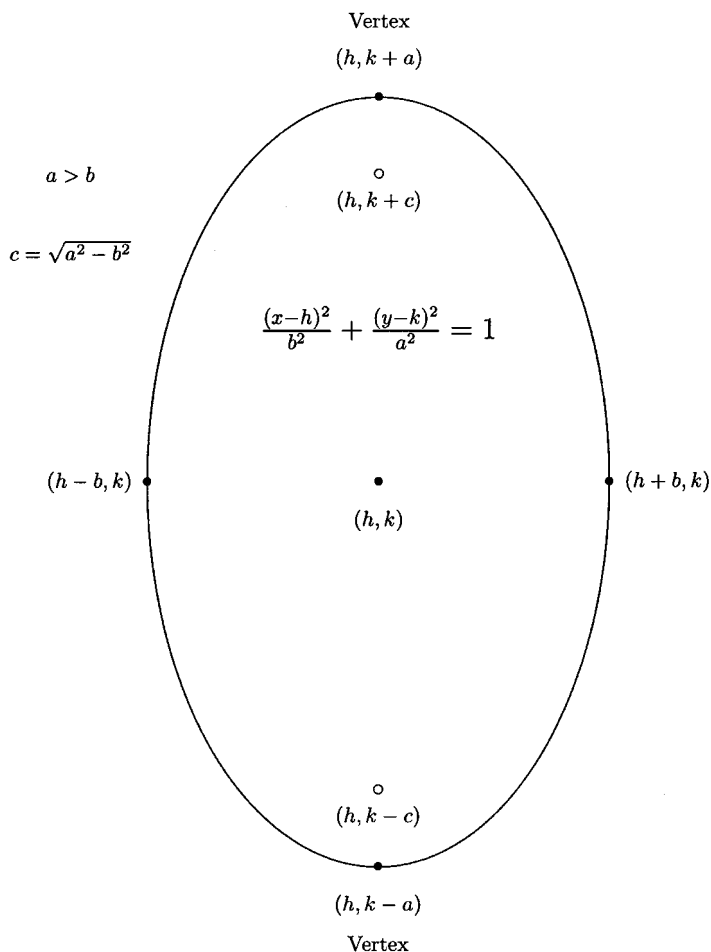

Fig. 12.12.

If all we want to do is to sketch the graph, all we really need to do is to plot the endpoints of the diameters and draw a rounded curve connecting them. For example, if we want to sketch the graph of  $\frac{(x+1)^2}{4} + \frac{(y-1)^2}{9} = 1$ ,  $a = 3$ ,  $b = 2$ ,  $h = -1$ , and  $k = 1$ . According to Figure 12.12, the diameters have coordinates  $(-1 - 2, 1) = (-3, 1)$ ,  $(-1 + 2, 1) = (1, 1)$ ,  $(-1, 1 + 3) = (-1, 4)$ , and  $(-1, 1 - 3) = (-1, -2)$ . (See Figure 12.13.)



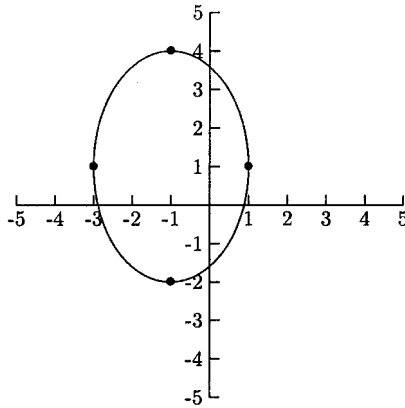

Fig. 12.13.

**DEFINITION:** An ellipse is the set of all points whose distances to two fixed points (the foci) is constant.

For example, the foci for  $\frac{x^2}{25} + \frac{y^2}{9} = 1$  are  $(-4, 0)$  and  $(4, 0)$ . If we take any point on this ellipse and calculate its distance to  $(-4, 0)$  and to  $(4, 0)$  and add these numbers, the sum will be 10. Two points on this ellipse are  $(0, 3)$  and  $(\frac{5}{3}, \sqrt{8})$ .

$$\begin{aligned} & \text{Distance from } (0, 3) \text{ to } (-4, 0) + \text{Distance from } (0, 3) \text{ to } (4, 0) \\ &= \sqrt{(-4 - 0)^2 + (0 - 3)^2} + \sqrt{(4 - 0)^2 + (0 - 3)^2} \\ &= \sqrt{16 + 9} + \sqrt{16 + 9} = \sqrt{25} + \sqrt{25} = 10 \end{aligned}$$

$$\begin{aligned} & \text{Distance from } (5/3, \sqrt{8}) \text{ to } (-4, 0) + \text{Distance from } (5/3, \sqrt{8}) \text{ to } (4, 0) \\ &= \sqrt{\left(-4 - \frac{5}{3}\right)^2 + (0 - \sqrt{8})^2} + \sqrt{\left(4 - \frac{5}{3}\right)^2 + (0 - \sqrt{8})^2} \\ &= \sqrt{\frac{289}{9} + 8} + \sqrt{\frac{49}{9} + 8} = \sqrt{\frac{361}{9}} + \sqrt{\frac{121}{9}} = 10 \end{aligned}$$

In the next set of problems, we will be given an equation for an ellipse. From the equation, we can find  $h$ ,  $k$ ,  $a$ , and  $b$ . With these numbers and the information in Figures 12.11 or 12.12 we can find the center, foci, and vertices.

## EXAMPLES

Find the center, foci, and vertices for the ellipse.

- $\frac{(x-3)^2}{16} + \frac{(y+5)^2}{25} = 1$

From the equation, we see that  $h = 3$ ,  $k = -5$ ,  $a^2$  and  $b^2$  are  $4^2$  and  $5^2$ , but which is  $a$  and which is  $b$ ?  $a$  needs to be the larger number, so  $a = 5$  and  $b = 4$ . This makes  $c = \sqrt{a^2 - b^2} = \sqrt{25 - 16} = 3$ . We need to use the information in Figure 12.12 because the larger denominator is under  $(y-k)^2$ .

Center:  $(h, k) = (3, -5)$

Foci:  $(h, k - c) = (3, -5 - 3) = (3, -8)$  and  $(h, k + c) = (3, -5 + 3) = (3, -2)$

Vertices:  $(h, k - a) = (3, -5 - 5) = (3, -10)$  and  $(h, k + a) = (3, -5 + 5) = (3, 0)$

- $\frac{x^2}{16} + (y - 2)^2 = 1$

To make it easier to find  $h$ ,  $k$ ,  $a$ , and  $b$ , we will rewrite the equation.

$$\frac{(x-0)^2}{16} + \frac{(y-2)^2}{1} = 1$$

Now we can see that  $h = 0$ ,  $k = 2$ ,  $a = 4$ ,  $b = 1$ ,  $c = \sqrt{a^2 - b^2} = \sqrt{16 - 1} = \sqrt{15}$ . Because the larger denominator is under  $(x-0)^2$ , we need to use the information in Figure 12.11.

Center:  $(h, k) = (0, 2)$

Foci:  $(h - c, k) = (0 - \sqrt{15}, 2) = (-\sqrt{15}, 2)$  and  $(h + c, k) = (0 + \sqrt{15}, 2) = (\sqrt{15}, 2)$

Vertices:  $(h - a, k) = (0 - 4, 2) = (-4, 2)$  and  $(h + a, k) = (0 + 4, 2) = (4, 2)$

Now that we can find this important information from an equation of an ellipse, we are ready to match graphs of ellipses to their equations.

## EXAMPLES

Match the equations with the graphs in Figures 12.14–12.16.

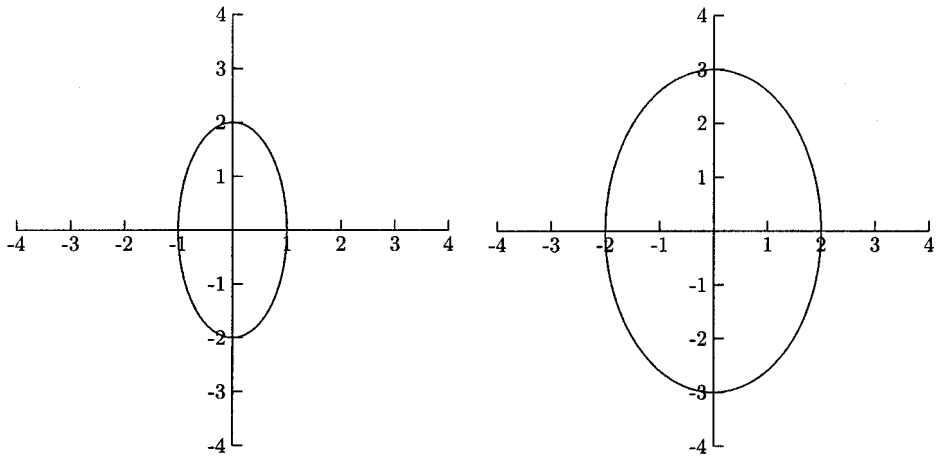

Fig. 12.14.

Fig. 12.15.

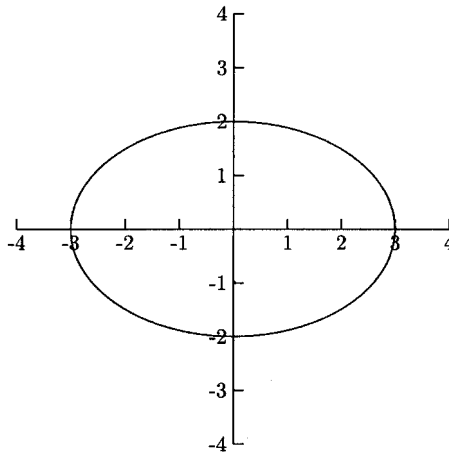

Fig. 12.16.

- $\frac{x^2}{4} + \frac{y^2}{9} = 1$

The larger denominator is under  $y^2$ , so we need to use the information in Figure 12.12. Because  $a = 3$ , we need to look for a graph with vertices (0, 3) and (0, -3). This graph is in Figure 12.15.

- $\frac{x^2}{9} + \frac{y^2}{4} = 1$

The larger denominator is under  $x^2$ , so we need to use the information in Figure 12.11. Because  $a = 3$ , the vertices are  $(-3, 0)$  and  $(3, 0)$ . This graph is in Figure 12.16.

- $x^2 + \frac{y^2}{4} = 1$

The larger denominator is under  $y^2$ , so we need to use the information in Figure 12.12. Because  $a = 2$ , the vertices are  $(0, 2)$  and  $(0, -2)$ . This graph is in Figure 12.14.

With as little as three points, we can find an equation of an ellipse. Using the formulas in Figures 12.11 and 12.12 and some algebra, we can find  $h$ ,  $k$ ,  $a$ , and  $b$ .

## EXAMPLES

Find an equation of the ellipse.

- The vertices are  $(-4, 2)$  and  $(6, 2)$ , and  $(1, 5)$  is a point on the graph. The  $y$ -coordinates are the same, so the major axis (the larger diameter) is horizontal, which means we need to use the information in Figure 12.11. The vertices are  $(h - a, k)$  and  $(h + a, k)$ . This means that  $h - a = -4$  and  $h + a = 6$ , and  $k = 2$ .

$$h - a = -4$$

$$\frac{h + a = 6}{\hline}$$

$$2h = 2$$

$$h = 1$$

$$1 - a = -4 \quad \text{Let } h = 1 \text{ in } h - a = -4$$

$$a = 5$$

So far we know that

$$\frac{(x - 1)^2}{25} + \frac{(y - 2)^2}{b^2} = 1.$$

Because  $(1, 5)$  is on the graph,  $\frac{(1-1)^2}{25} + \frac{(5-2)^2}{b^2} = 1$ . Solving this equation for  $b$ , we find that  $b = 3$ . The equation is

$$\frac{(x-1)^2}{25} + \frac{(y-2)^2}{9} = 1.$$

- The foci are  $(-4, -10)$  and  $(-4, 14)$  and  $(-4, 15)$  is a vertex. The  $x$ -values of foci are the same, so the major axis is vertical. This tells us that we need to use the information in Figure 12.12.  $(h, k - c) = (-4, -10)$  and  $(h, k + c) = (-4, 14)$ , so  $h = -4$ ,  $k - c = -10$  and  $k + c = 14$ .

$$k - c = -10$$

$$\underline{k + c = 14}$$

$$2k = 4$$

$$k = 2$$

$$2 - c = -10 \quad \text{Let } k = 2 \text{ in } k - c = -10$$

$$c = 12$$

Because  $(-4, 15)$  is a vertex,  $k + a = 15$ , so  $2 + a = 15$  and  $a = 13$ . All we need to finish is to find  $b$ . Let  $a = 13$  and  $c = 12$  in  $c = \sqrt{a^2 - b^2}$ :  $12 = \sqrt{13^2 - b^2}$ . Solving this for  $b$ , we have  $b = 5$ . The equation is

$$\frac{(x+4)^2}{25} + \frac{(y-2)^2}{169} = 1.$$

The *eccentricity* of an ellipse is a number that measures how flat it is. The formula is  $e = \frac{c}{a}$ . This number ranges between 0 and 1. The closer to 1 the eccentricity of an ellipse is, the flatter it is. If  $e = \frac{c}{a} = 0$ , then the ellipse is a circle. In a circle, the center and foci are all the same point, and  $a$  and  $b$  are the same number. For example,  $\frac{(x-5)^2}{9} + \frac{(y-4)^2}{9} = 1$  is a circle with center  $(5, 4)$  and radius  $\sqrt{9} = 3$ . Usually we see equations of circles in the form  $(x - h)^2 + (y - k)^2 = r^2$ .

## EXAMPLES

Find the ellipse's eccentricity.

- $\frac{x^2}{9} + \frac{y^2}{25} = 1$

$$a = 5, b = 3, c = \sqrt{25 - 9} = 4 \text{ and } e = \frac{c}{a} = \frac{4}{5}$$

- $\frac{(x + 8)^2}{144} + \frac{(y + 6)^2}{169} = 1$

$a = 13, b = 12, c = \sqrt{169 - 144} = 5, e = \frac{c}{a} = \frac{5}{13}$  This ellipse is more rounded than the first because  $e$  is closer to 0.

## PRACTICE

1. Identify the center, foci, vertices, and eccentricity for

$$\frac{x^2}{169} + \frac{(y - 10)^2}{25} = 1.$$

2. Identify the center, foci, vertices, and eccentricity for

$$\frac{(x + 9)^2}{20^2} + \frac{(y + 2)^2}{29^2} = 1.$$

3. Identify the center and radius for the circle

$$\frac{(x + 6)^2}{49} + \frac{(y - 1)^2}{49} = 1.$$

For Problems 4–7, match the equation with the graph in Figures 12.17–12.20.

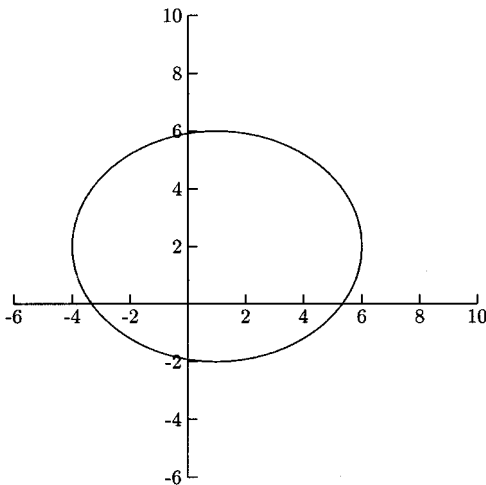

Fig. 12.17.

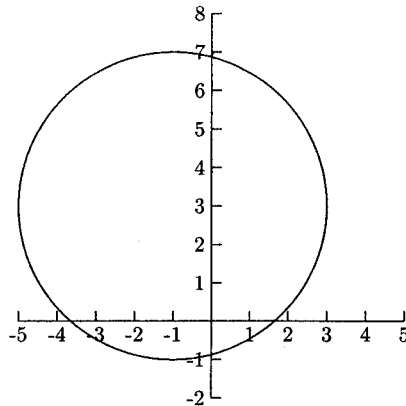

Fig. 12.18.

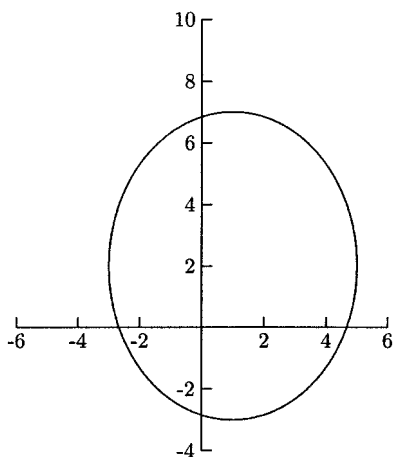

Fig. 12.19.

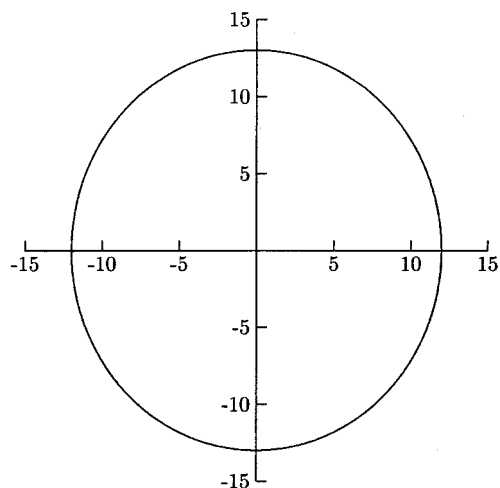

Fig. 12.20.

$$4. \frac{(x-1)^2}{16} + \frac{(y-2)^2}{25} = 1$$

$$5. \frac{x^2}{144} + \frac{y^2}{169} = 1$$

$$6. \frac{(x+1)^2}{16} + \frac{(y-3)^2}{16} = 1$$

$$7. \frac{(x-1)^2}{25} + \frac{(y-2)^2}{16} = 1$$

## SOLUTIONS

$$1. h = 0, k = 10, a = 13, b = 5, c = \sqrt{a^2 - b^2} = \sqrt{169 - 25} = 12$$

Center:  $(0, 10)$

Foci:  $(h-c, k) = (0-12, 10) = (-12, 10)$  and  $(h+c, k) = (0+12, 10) = (12, 10)$

Vertices:  $(h-a, k) = (0-13, 10) = (-13, 10)$  and  $(h+a, k) = (0+13, 10) = (13, 10)$

$$\text{Eccentricity: } \frac{c}{a} = \frac{12}{13}$$

2.  $h = -9, k = -2, a = 29, b = 20, c = \sqrt{29^2 - 20^2} = 21$

Center:  $(-9, -2)$

Foci:  $(h, k - c) = (-9, -2 - 21) = (-9, -23)$  and  $(h, k + c) = (-9, -2 + 21) = (-9, 19)$

Vertices:  $(h, k - a) = (-9, -2 - 29) = (-9, -31)$  and  $(h, k + a) = (-9, -2 + 29) = (-9, 27)$

Eccentricity:  $\frac{c}{a} = \frac{21}{29}$

3. The center is  $(-6, 1)$ , and the radius is 7.
4. Figure 12.19
5. Figure 12.20
6. Figure 12.18
7. Figure 12.17

## Hyperbolas

The last conic section is the hyperbola. Hyperbolas are formed when a slice is made through both parts of a double cone. The graph of a hyperbola comes in two pieces called *branches*. Like ellipses, hyperbolas have a center, two foci, and two vertices. Hyperbolas also have two slant asymptotes. The definition of a hyperbola involves the distance between points on the graph and two fixed points.

**DEFINITION:** A hyperbola is the set of all points such that the difference of the distance between a point and two fixed points (the foci) is constant.

For example, the foci for  $\frac{x^2}{9} - \frac{y^2}{16} = 1$  are  $(-5, 0)$  and  $(5, 0)$ . For any point on the hyperbola, the distance between this point and one focus minus the distance between the same point and the other focus is 6. Two points on the hyperbola are  $(6, \sqrt{48})$  and  $(12, \sqrt{240})$ .

$$\begin{aligned} & \text{Distance from } (6, \sqrt{48}) \text{ to } (-5, 0) - \text{Distance from } (6, \sqrt{48}) \text{ to } (5, 0) \\ &= \sqrt{(-5 - 6)^2 + (0 - \sqrt{48})^2} - \sqrt{(5 - 6)^2 + (0 - \sqrt{48})^2} \\ &= \sqrt{121 + 48} - \sqrt{1 + 48} = 13 - 7 = 6 \end{aligned}$$



And

$$\begin{aligned} & \text{Distance from } (12, \sqrt{240}) \text{ to } (-5, 0) - \text{Distance from } (12, \sqrt{240}) \text{ to } (5, 0) \\ &= \sqrt{(-5 - 12)^2 + (0 - \sqrt{240})^2} - \sqrt{(5 - 12)^2 + (0 - \sqrt{240})^2} \\ &= \sqrt{289 + 240} - \sqrt{49 + 240} = 23 - 17 = 6 \end{aligned}$$

Equations of hyperbolas come in one of two forms.

$$\frac{(x-h)^2}{a^2} - \frac{(y-k)^2}{b^2} = 1 \quad \text{or} \quad \frac{(y-k)^2}{a^2} - \frac{(x-h)^2}{b^2} = 1$$

If the  $x^2$  term is positive, one branch opens to the left and the other to the right. If the  $y^2$  term is positive, one branch opens up and the other down. The formulas for these two forms are in Figures 12.21 and 12.22.

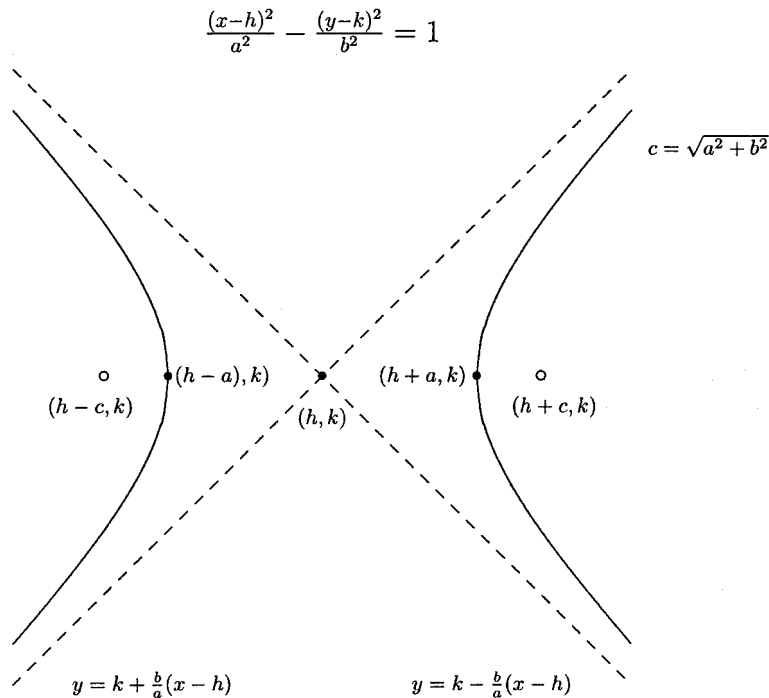

Fig. 12.21.

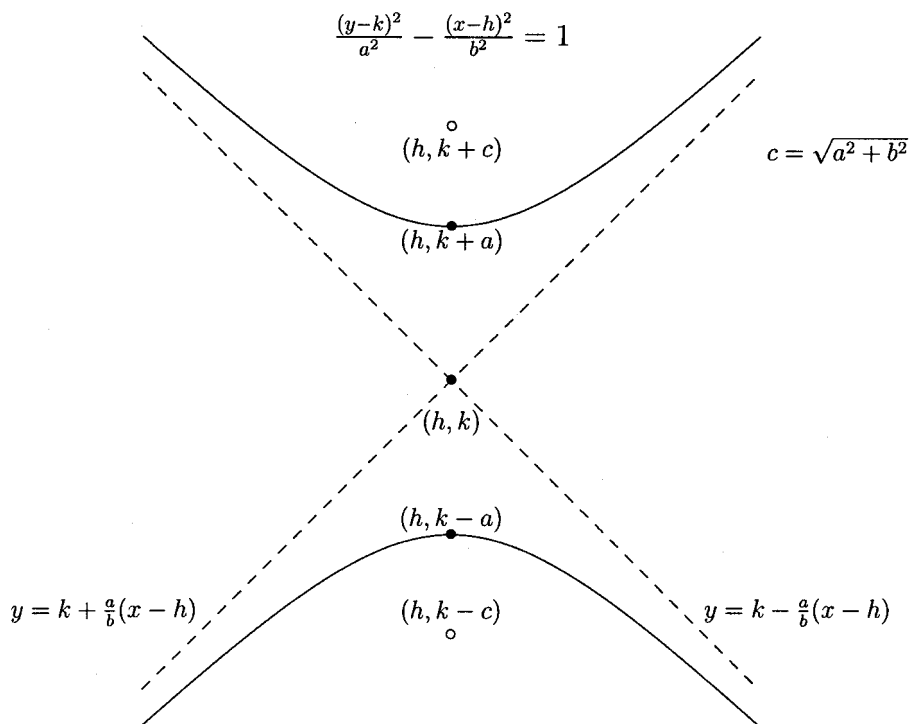

Fig. 12.22.

We can sketch a hyperbola by plotting the vertices and sketching the asymptotes, using dashed lines. We should also plot two points to the left and two points to the right of the vertices.

### EXAMPLE

- Sketch the graph for  $\frac{y^2}{4} - x^2 = 1$ .

Because  $y^2$  is positive, we will use the information in Figure 12.22. The center is  $(0, 0)$ ,  $a = 2$ , and  $b = 1$ . The vertices are  $(h, k+a) = (0, 0+2) = (0, 2)$  and  $(h, k-a) = (0, 0-2) = (0, -2)$ . The asymptote formulas are  $y = k - \frac{a}{b}(x-h)$  and  $y = k + \frac{a}{b}(x-h)$ . Using our numbers for  $h, k, a$ , and  $b$ , we have  $y = -2x$  and  $y = 2x$ . We will use  $x = 4$  and  $x = -4$  for our extra points. If we let  $x = 4$  or  $x = -4$ , we get two  $y$ -values,  $\pm\sqrt{68}$ . These give us four more points— $(4, \sqrt{68})$ ,  $(4, -\sqrt{68})$ ,  $(-4, \sqrt{68})$ , and  $(-4, -\sqrt{68})$ . (see Figure 12.23.)

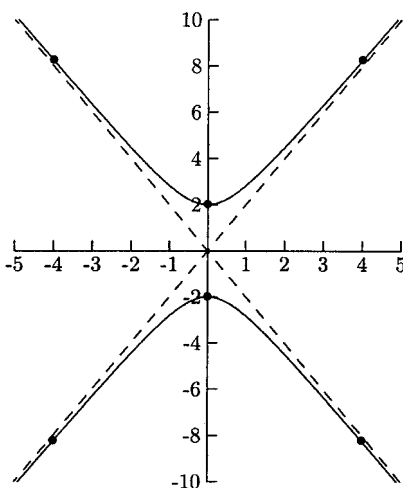

Fig. 12.23.

In the next problem, we will find the center, vertices, foci, and asymptotes for given hyperbolas. Once we have determined whether  $x^2$  is positive or  $y^2$  is positive, we can decide on which formulas to use, those in Figure 12.21 or Figure 12.22.

## EXAMPLES

Find the center, vertices, foci, and asymptotes for the hyperbola.

- $$\frac{(x + 7)^2}{36} - \frac{(y + 4)^2}{64} = 1$$

Because  $x^2$  is positive, we will use the information in Figure 12.21.

$$h = -7, k = -4, a = 6, b = 8, c = \sqrt{36 + 64} = 10$$

$$\text{Center: } (-7, -4)$$

$$\text{Vertices: } (h - a, k) = (-7 - 6, -4) = (-13, -4) \text{ and } (h + a, k) = (-7 + 6, -4) = (-1, -4)$$

$$\text{Foci: } (h - c, k) = (-7 - 10, -4) = (-17, -4) \text{ and } (h + c, k) = (-7 + 10, -4) = (3, -4)$$

$$\begin{aligned} \text{Asymptotes: } y &= k - \frac{b}{a}(x - h) = -4 - \frac{8}{6}(x + 7) = -\frac{4}{3}x - \frac{40}{3} \text{ and} \\ y &= k + \frac{b}{a}(x - h) = -4 + \frac{8}{6}(x + 7) = \frac{4}{3}x + \frac{16}{3} \end{aligned}$$

- $\frac{y^2}{144} - \frac{(x-1)^2}{25} = 1$

Because  $y^2$  is positive, we need to use the information in Figure 12.22.

$$h = 1, k = 0, a = 12, b = 5, c = \sqrt{144 + 25} = 13$$

Center: (1, 0)

Vertices:  $(h, k - a) = (1, 0 - 12) = (1, -12)$  and  $(h, k + a) = (1, 0 + 12) = (1, 12)$

Foci:  $(h, k - c) = (1, 0 - 13) = (1, -13)$  and  $(h, k + c) = (1, 0 + 13) = (1, 13)$

Asymptotes:  $y = k - \frac{a}{b}(x - h) = 0 - \frac{12}{5}(x - 1) = -\frac{12}{5}x + \frac{12}{5}$  and  $y = k + \frac{a}{b}(x - h) = 0 + \frac{12}{5}(x - 1) = \frac{12}{5}x - \frac{12}{5}$

In the next problem, we will match equations of hyperbolas with their graphs. Being able to identify the vertices will not be enough. We will also need to use the equations of the asymptotes to find  $b$  (we will know  $a$  from the vertices). Because the center of each hyperbola will be at (0, 0), the asymptotes will either be  $y = \frac{a}{b}x$  and  $y = -\frac{a}{b}x$  or  $y = \frac{b}{a}x$  and  $y = -\frac{b}{a}x$ .

## EXAMPLES

Match the equation with its graph in Figures 12.24–12.27.

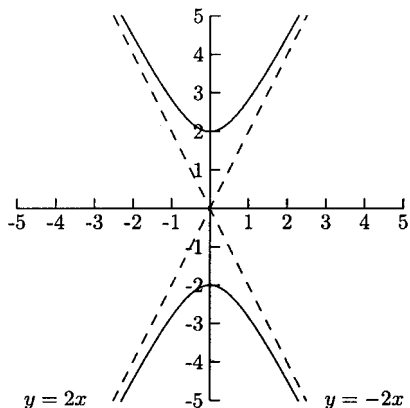

Fig. 12.24.

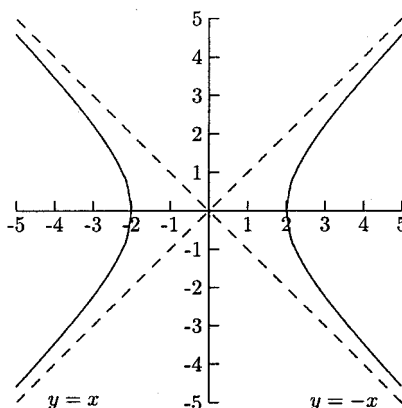

Fig. 12.25.

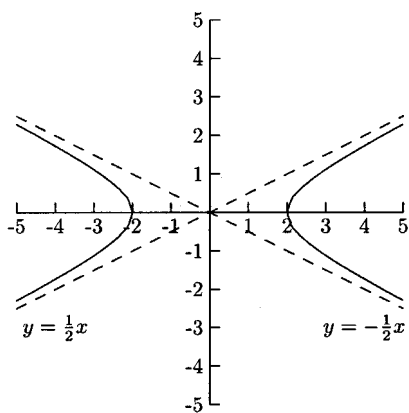

Fig. 12.26.

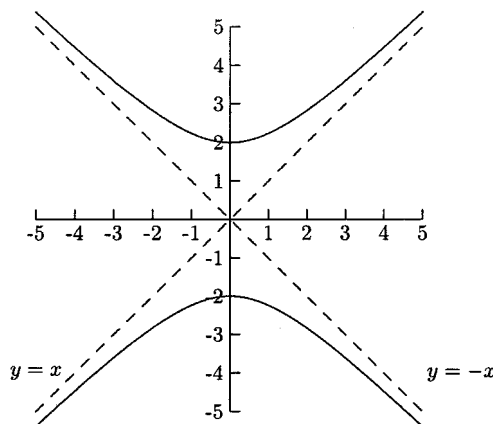

Fig. 12.27.

- $\frac{x^2}{4} - \frac{y^2}{4} = 1$

The vertices are  $(-2, 0)$  and  $(2, 0)$ . The slopes of the asymptotes are  $-1$  and  $1$ . The graph is in Figure 12.25.

- $\frac{x^2}{4} - y^2 = 1$

The vertices are  $(-2, 0)$  and  $(2, 0)$ . The slopes of the asymptotes are  $-\frac{1}{2}$  and  $\frac{1}{2}$ . The graph is in Figure 12.26.

- $\frac{y^2}{4} - \frac{x^2}{4} = 1$

The vertices are  $(0, -2)$  and  $(0, 2)$ . The slopes of the asymptotes are  $-1$  and  $1$ . The graph is in Figure 12.27.

- $\frac{y^2}{4} - x^2 = 1$

The vertices are  $(0, -2)$  and  $(0, 2)$ . The slopes of the asymptotes are  $-2$  and  $2$ . The graph is in Figure 12.24.

We can find the equation for a hyperbola when we know some points or a point and the asymptotes. If we have the vertices and foci, then finding an equation for a hyperbola will be similar to finding an equation for an ellipse. If we are given the vertices and asymptotes or foci and asymptotes, we will need to use the slope of one of the asymptotes to find either  $a$  or  $b$  (we will know one but not the other from the vertices or foci). The first thing we need to decide is which formulas

to use—those in Figures 12.21 or Figure 12.22. If the vertices or foci are on the same horizontal line (the  $y$ -coordinates are the same), we will use Figure 12.21. If they are on the same vertical line (the  $x$ -coordinates are the same), we will use Figure 12.22.

## EXAMPLES

Find an equation for the hyperbola.

- The vertices are  $(3, -1)$  and  $(3, 7)$  and  $y = \frac{4}{3}x - 1$  is an asymptote. The vertices are on the same vertical line, so we need to use the information in Figure 12.22. The vertices are  $(h, k - a) = (3, -1)$  and  $(h, k + a) = (3, 7)$ . This gives us  $h = 3$ ,  $k - a = -1$  and  $k + a = 7$ .

$$k + a = 7$$

$$\underline{k - a = -1}$$

$$2k = 6$$

$$k = 3$$

$$3 + a = 7 \quad \text{Let } k = 3 \text{ in } k + a = 7$$

$$a = 4$$

The center is  $(3, 3)$  and  $a = 4$ . Once we have  $b$ , we will be done. The slope of one of the asymptotes in Figure 12.22 is  $\frac{a}{b}$ , so we have  $\frac{a}{b} = \frac{4}{b} = \frac{4}{3}$ , so  $b = 3$ . The equation is

$$\frac{(y - 3)^2}{16} - \frac{(x - 3)^2}{9} = 1.$$

- The vertices are  $(-8, 5)$  and  $(4, 5)$ , and the foci are  $(-12, 5)$  and  $(8, 5)$ . The vertices and foci are on the same horizontal line, so we need to use the information in Figure 12.21. The vertices are  $(h - a, k) = (-8, 5)$  and  $(h + a, k) = (4, 5)$ . Now we know  $k = 5$  and we have the system  $h - a = -8$  and  $h + a = 4$ .

$$h - a = -8$$

$$\underline{h + a = 4}$$

$$2h = -4$$

$$h = -2$$

$$-2 - a = -8 \quad \text{Let } h = -2 \text{ in } h - a = -8$$

$$a = 6$$

A focus is  $(h - c, k) = (-2 - c, 5) = (-12, 5)$ , which gives us  $-2 - c = -12$ . Now that we see that  $c = 10$ , we can put this and  $a = 6$  in  $c = \sqrt{a^2 + b^2}$  to find  $b$ .

$$10 = \sqrt{36 + b^2}$$

$$100 = 36 + b^2$$

$$8 = b$$

The equation is

$$\frac{(x + 2)^2}{36} - \frac{(y - 5)^2}{64} = 1.$$

## PRACTICE

1. Find the center, vertices, foci, and asymptotes for

$$\frac{y^2}{16} - \frac{(x - 5)^2}{9} = 1.$$

2. Find the center, vertices, foci, and asymptotes for

$$\frac{(x + 8)^2}{49} - \frac{(y + 6)^2}{576} = 1.$$

3. Find an equation for the hyperbola having vertices  $(-4, 2)$  and  $(12, 2)$  and foci  $(-6, 2)$  and  $(14, 2)$ .
4. Find an equation for the hyperbola having vertices  $(-8, 0)$  and  $(-4, 0)$  and with an asymptote  $y = \frac{1}{2}x + 3$ .

In Problems 5–7, match the graphs in Figures 12.28–12.30 with their equations.

5.  $(y - 1)^2 - (x - 1)^2 = 1$

6.  $(x - 1)^2 - (y - 1)^2 = 1$

7.  $\frac{(x - 1)^2}{4} - (y - 1)^2 = 1$

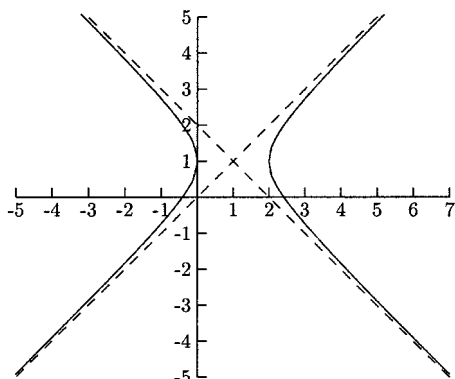

Fig. 12.28.

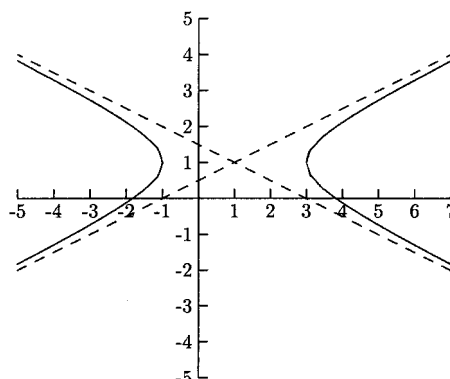

Fig. 12.29.

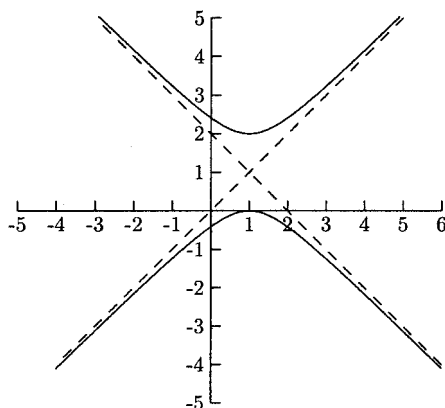

Fig. 12.30.

## SOLUTIONS

1.  $h = 5, k = 0, a = 4, b = 3,$  and  $c = \sqrt{16 + 9} = 5$

Center:  $(5, 0)$

Vertices:  $(h, k - a) = (5, 0 - 4) = (5, -4)$  and  $(h, k + a) = (5, 0 + 4) = (5, 4)$

Foci:  $(h, k - c) = (5, 0 - 5) = (5, -5)$  and  $(h, k + c) = (5, 0 + 5) = (5, 5)$

Asymptotes:  $y = k - \frac{a}{b}(x - h) = 0 - \frac{4}{3}(x - 5) = -\frac{4}{3}x + \frac{20}{3}$  and  $y = k + \frac{a}{b}(x - h) = 0 + \frac{4}{3}(x - 5) = \frac{4}{3}x - \frac{20}{3}$



2.  $h = -8, k = -6, a = 7, b = 24$ , and  $c = \sqrt{49 + 576} = 25$

Center:  $(-8, -6)$

Vertices:  $(h - a, k) = (-8 - 7, -6) = (-15, -6)$  and  $(h + a, k) = (-8 + 7, -6) = (-1, -6)$

Foci:  $(h - c, k) = (-8 - 25, -6) = (-33, -6)$  and  $(h + c, k) = (-8 + 25, -6) = (17, -6)$

Asymptotes:  $y = k - \frac{b}{a}(x - h) = -6 - \frac{24}{7}(x + 8) = -\frac{24}{7}x - \frac{234}{7}$  and

$y = k + \frac{b}{a}(x - h) = -6 + \frac{24}{7}(x + 8) = \frac{24}{7}x + \frac{150}{7}$

3. The vertices are  $(-4, 2)$  and  $(12, 2)$ , which gives us  $k = 2$  and  $(h - a, k) = (-4, 2)$  and  $(h + a, k) = (12, 2)$ .

$$h - a = -4$$

$$\frac{h + a}{\quad} = 12$$

$$2h = 8$$

$$h = 4$$

$$4 - a = -4 \quad \text{Let } h = 4 \text{ in } h - a = -4$$

$$a = 8$$

A focus is  $(-6, 2)$ , which gives us  $(h - c, k) = (-6, 2)$  and  $h - c = 4 - c = -6$ . Solving  $4 - c = -6$  gives us  $c = 10$ . We can find  $b$  by letting  $a = 8$  and  $c = 10$  in  $c = \sqrt{a^2 + b^2}$ .

$$c = \sqrt{a^2 + b^2}$$

$$10 = \sqrt{64 + b^2}$$

$$100 = 64 + b^2$$

$$6 = b$$

The equation is

$$\frac{(x - 4)^2}{64} - \frac{(y - 2)^2}{36} = 1.$$

4.  $(h - a, k) = (-8, 0)$  and  $(h + a, k) = (-4, 0)$ , so  $k = 0$  and we have the following system.

$$h - a = -8$$

$$\underline{h + a = -4}$$

$$2h = -12$$

$$h = -6$$

$$-6 - a = -8 \quad \text{Let } h = -6 \text{ in } h - a = -8$$

$$a = 2.$$

The slope of an asymptote is  $\frac{1}{2}$ , so  $\frac{b}{a} = \frac{b}{2} = \frac{1}{2}$  and  $b = 1$ . The equation is

$$\frac{(x + 6)^2}{4} - y^2 = 1.$$

5. Figure 12.30
6. Figure 12.28
7. Figure 12.29

In order to use a graphing calculator to graph a conic section, the equation probably needs to be entered as two separate functions. For example, the graph of  $y^2 = x$  could be entered as  $y = \sqrt{x}$  and  $y = -\sqrt{x}$ . To use a graphing calculator to graph a conic section that is not a function, solve for  $y$ . When taking the square root of both sides, we use a “ $\pm$ ” symbol on one of the sides. It is this sign that gives us two separate equations.

## EXAMPLES

Solve for  $y$ .

$$\bullet (y - 1)^2 + \frac{(x + 3)^2}{9} = 1$$

$$(y - 1)^2 + \frac{(x + 3)^2}{9} = 1$$

$$(y - 1)^2 = 1 - \frac{(x + 3)^2}{9}$$

$$y - 1 = \pm \sqrt{1 - \frac{(x + 3)^2}{9}}$$

$$y = 1 \pm \sqrt{1 - \frac{(x + 3)^2}{9}}$$

$$y = 1 + \sqrt{1 - \frac{(x + 3)^2}{9}}, \quad 1 - \sqrt{1 - \frac{(x + 3)^2}{9}}$$

$$\bullet \quad \frac{x^2}{9} - \frac{(y + 2)^2}{4} = 1$$

$$\frac{x^2}{9} - \frac{(y + 2)^2}{4} = 1$$

$$-\frac{(y + 2)^2}{4} = 1 - \frac{x^2}{9}$$

$$\frac{(y + 2)^2}{4} = -1 + \frac{x^2}{9}$$

$$(y + 2)^2 = 4 \left( -1 + \frac{x^2}{9} \right)$$

$$y + 2 = \pm \sqrt{4 \left( -1 + \frac{x^2}{9} \right)}$$

$$y = -2 \pm \sqrt{4 \left( -1 + \frac{x^2}{9} \right)}$$

$$y = -2 + \sqrt{4 \left( -1 + \frac{x^2}{9} \right)}, \quad y = -2 - \sqrt{4 \left( -1 + \frac{x^2}{9} \right)}$$

Equations of conic sections do not always come in the convenient forms we have been using. Sometimes they come in the general form  $Ax^2 + Bxy + Cy^2 + Dx + Ey + F = 0$ . When  $A$  and  $C$  are equal (and  $B = 0$ ), the graph is a circle. If  $A$  and  $C$  are positive and not equal (and  $B = 0$ ), the graph is an ellipse. If  $A$  and  $C$  have different signs (and  $B = 0$ ), the graph is a hyperbola. If only one of  $A$  or  $C$  is nonzero (and  $B = 0$ ), the graph is a parabola. There are some conic sections whose entire graph is one point. These are called *degenerate conics*. We can rewrite

an equation in the general form in the standard form (the form we have been using) by completing the square.

## EXAMPLES

Rewrite the equation in standard form.

- $x^2 - 2x - 4y = 11$

Because there is no  $y^2$  term, the graph of this equation is a parabola that opens up or down. The standard equation is  $(x - h)^2 = 4p(y - k)$ . We need to have the  $x$  terms on one side of the equation and the other terms on the other side.

$$x^2 - 2x - 4y = 11$$

$$x^2 - 2x = 4y + 11$$

$$x^2 - 2x + \left(\frac{2}{2}\right)^2 = 4y + 11 + \left(\frac{2}{2}\right)^2$$

$$x^2 - 2x + 1 = 4y + 12$$

$$(x - 1)^2 = 4(y + 3)$$

- $-9x^2 + 16y^2 - 18x - 160y + 247 = 0$

Because the signs on  $x^2$  and  $y^2$  are different, the graph of this equation is a hyperbola. The standard form for this equation is  $\frac{(y-k)^2}{a^2} - \frac{(x-h)^2}{b^2} = 1$ .

$$-9x^2 + 16y^2 - 18x - 160y + 247 = 0$$

$$16y^2 - 160y - 9x^2 - 18x = -247$$

$$16(y^2 - 10y) - 9(x^2 + 2x) = -247$$

$$\begin{aligned} 16\left(y^2 - 10y + \left(\frac{10}{2}\right)^2\right) - 9\left(x^2 + 2x + \left(\frac{2}{2}\right)^2\right) \\ = -247 + 16\left(\frac{10}{2}\right)^2 - 9\left(\frac{2}{2}\right)^2 \end{aligned}$$

$$16(y - 5)^2 - 9(x + 1)^2 = 144$$

$$\frac{16(y-5)^2}{144} - \frac{9(x+1)^2}{144} = \frac{144}{144}$$

$$\frac{(y-5)^2}{9} - \frac{(x+1)^2}{16} = 1$$

**PRACTICE**

1. Solve for
- $y$

$$\frac{y^2}{4} - \frac{(x-3)^2}{9} = 1$$

2. Solve for
- $y$

$$\frac{(x+10)^2}{25} + \frac{(y+3)^2}{25} = 1$$

3. Rewrite the equation in standard form:
- $36x^2 + 9y^2 - 216x - 72y + 144 = 0$
- .

**SOLUTIONS**

1. 
$$\frac{y^2}{4} - \frac{(x-3)^2}{9} = 1$$

$$\frac{y^2}{4} = 1 + \frac{(x-3)^2}{9}$$

$$y^2 = 4 \left( 1 + \frac{(x-3)^2}{9} \right)$$

$$y = \pm \sqrt{4 \left( 1 + \frac{(x-3)^2}{9} \right)}$$

2. 
$$\frac{(x+10)^2}{25} + \frac{(y+3)^2}{25} = 1$$

$$\frac{(y+3)^2}{25} = 1 - \frac{(x+10)^2}{25}$$

$$(y+3)^2 = 25 \left( 1 - \frac{(x+10)^2}{25} \right)$$

$$y + 3 = \pm \sqrt{25 \left( 1 - \frac{(x + 10)^2}{25} \right)}$$

$$y = -3 \pm \sqrt{25 \left( 1 - \frac{(x + 10)^2}{25} \right)}$$

3.  $36x^2 + 9y^2 - 216x - 72y + 144 = 0$

$$36x^2 - 216x + 9y^2 - 72y = -144$$

$$36(x^2 - 6x) + 9(y^2 - 8y) = -144$$

$$36(x^2 - 6x + 9) + 9(y^2 - 8y + 16) = -144 + 36(9) + 9(16)$$

$$36(x - 3)^2 + 9(y - 4)^2 = 324$$

$$\frac{36(x - 3)^2}{324} + \frac{9(y - 4)^2}{324} = \frac{324}{324}$$

$$\frac{(x - 3)^2}{9} + \frac{(y - 4)^2}{36} = 1$$

## CHAPTER 12 REVIEW

1. What is the directrix for the parabola  $(y + 1)^2 = -6(x - 3)$ ?

- (a)  $x = \frac{3}{2}$       (b)  $x = \frac{9}{2}$       (c)  $y = -\frac{5}{2}$       (d)  $y = \frac{1}{2}$

2. What is the focus for the parabola  $(y + 1)^2 = -6(x - 3)$ ?

- (a)  $(\frac{3}{2}, -1)$       (b)  $(\frac{9}{2}, -1)$       (c)  $(3, \frac{1}{2})$       (d)  $(3, -\frac{5}{2})$

3. What are the vertices for the ellipse

$$\frac{(x - 1)^2}{9} + \frac{(y - 2)^2}{25} = 1?$$

- (a)  $(-2, 2)$  and  $(4, 2)$       (b)  $(-4, 2)$  and  $(6, 2)$   
 (c)  $(1, -3)$  and  $(1, 7)$       (d)  $(1, -1)$  and  $(1, 5)$

4. What are the foci for the ellipse

$$\frac{(x-1)^2}{9} + \frac{(y-2)^2}{25} = 1?$$

- (a)  $(-3, 2)$  and  $(5, 2)$                       (b)  $(1 - \sqrt{34}, 2)$  and  $(1 + \sqrt{34}, 2)$   
 (c)  $(1, -2)$  and  $(1, 6)$                       (d)  $(1, 2 - \sqrt{34})$  and  $(1, 2 + \sqrt{34})$

5. Which line is an asymptote for the hyperbola

$$(x-5)^2 - \frac{(y+1)^2}{4} = 1?$$

- (a)  $y = 2x - 11$                                   (b)  $y = -2x - 9$   
 (c)  $y = \frac{1}{2}x - \frac{7}{2}$                                       (d)  $y = -\frac{1}{2}x + \frac{3}{2}$

6. Solve for  $y$ .

$$(x-4)^2 - \frac{(y-6)^2}{25} = 1$$

- (a)  $y = 6 \pm 5\sqrt{-1 + (x-4)^2}$                       (b)  $y = 6 \pm 5\sqrt{1 - (x-4)^2}$   
 (c)  $y = -6 \pm 5\sqrt{1 + (x-4)^2}$                       (d)  $y = -6 \pm 5\sqrt{1 - (x-4)^2}$

7. What is the center and radius for the circle  $(x+3)^2 + (y-4)^2 = 9$ ?

- (a) The center is  $(-3, 4)$ , and the radius is 81.  
 (b) The center is  $(-3, 4)$ , and the radius is 3.  
 (c) The center is  $(3, -4)$ , and the radius is 81.  
 (d) The center is  $(3, -4)$ , and the radius is 3.

8. The graph in Figure 12.31 is the graph of which equation?

(a)  $y^2 = 4x$       (b)  $y^2 = -4x$       (c)  $x^2 = -4y$       (d)  $x^2 = 4y$

9. Find an equation of the ellipse with vertices  $(8, -6)$  and  $(8, 4)$  with a focus at  $(8, 2)$ .

(a)  $\frac{(x-8)^2}{16} + \frac{(y+1)^2}{25} = 1$                       (b)  $\frac{(x-8)^2}{25} + \frac{(y+1)^2}{16} = 1$   
 (c)  $\frac{(x-8)^2}{16} - \frac{(y+1)^2}{25} = 1$                       (d)  $\frac{(x-8)^2}{25} + \frac{(y+1)^2}{16} = 1$

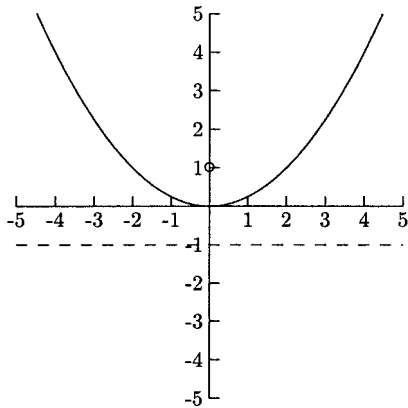

Fig. 12.31.

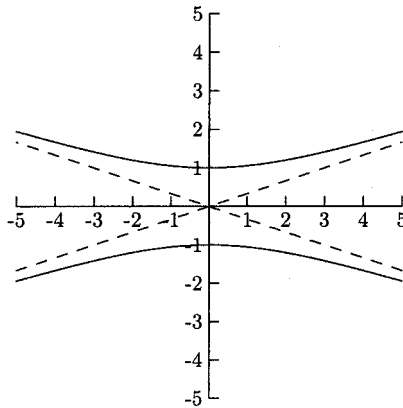

Fig. 12.32.

10. Which equation is the equation of a hyperbola with center (1, 0) and with asymptote  $y = 2x - 2$ ?

(a)  $y^2 - \frac{(x - 1)^2}{4} = 1$

(b)  $\frac{y^2}{4} + (x - 1)^2 = 1$

(c)  $\frac{(x - 1)^2}{4} - y^2 = 1$

(d)  $(x - 1)^2 - \frac{y^2}{4} = 1$

11. The graph in Figure 12.32 is the graph of which equation?

(a)  $x^2 - \frac{y^2}{9} = 1$

(b)  $\frac{x^2}{9} - y^2 = 1$

(c)  $\frac{y^2}{9} - x^2 = 1$

(d)  $y^2 - \frac{x^2}{9} = 1$

**SOLUTIONS**

1. B      2. A      3. C      4. C      5. A      6. A  
 7. B      8. D      9. A      10. D      11. D



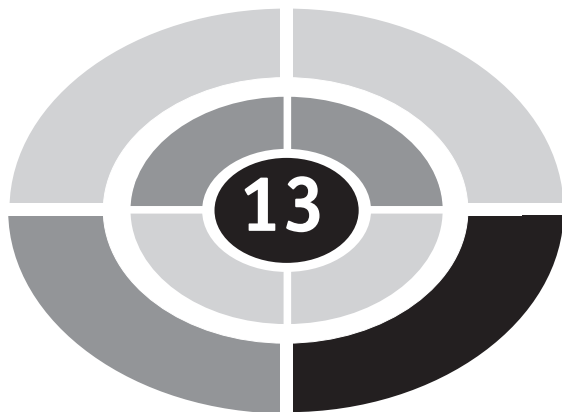

## CHAPTER

# Trigonometry

Trigonometry has been used for over two thousand years to solve many real-world problems, among them surveying, navigating, and problems in engineering. Another important use is analytic—the trigonometric functions and their graphs are important in several mathematics courses. The *unit circle* is the basis of analytic trigonometry. The unit circle is the circle centered at the origin that has radius 1. See Figure 13.1.

Angles have two sides, the initial side and the terminal side. On the unit circle, the initial side is the positive part of the  $x$ -axis. The terminal side is the side that rotates. See Figure 13.2

A positive angle rotates counterclockwise, ↶. A negative angle rotates clockwise, ↷. Angles on the unit circle are often measured in *radians*. Radian measure is based on the circumference of the unit circle,  $C = 2\pi r$ . The radius is 1, so  $2\pi r = 2\pi$ . An angle that rotates all the way around the circle is  $2\pi$  radians, half-way around is  $\pi$  radians, one-third the way is  $\frac{1}{3}(2\pi) = \frac{2\pi}{3}$  radians, and so on. The relationship  $2\pi$  radians =  $360^\circ$  gives us two equations.

$$\frac{\pi}{180} \text{ radians} = 1^\circ \quad \text{and} \quad \frac{180^\circ}{\pi} = 1 \text{ radian}$$

XI



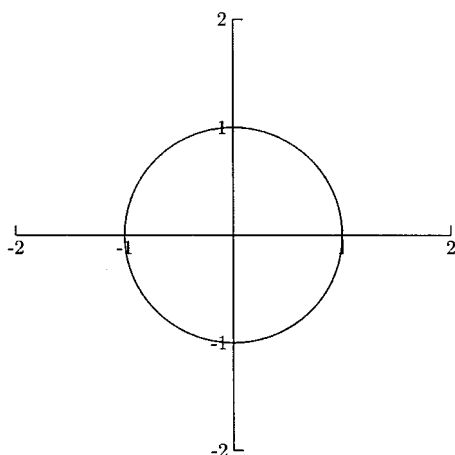

Fig. 13.1.

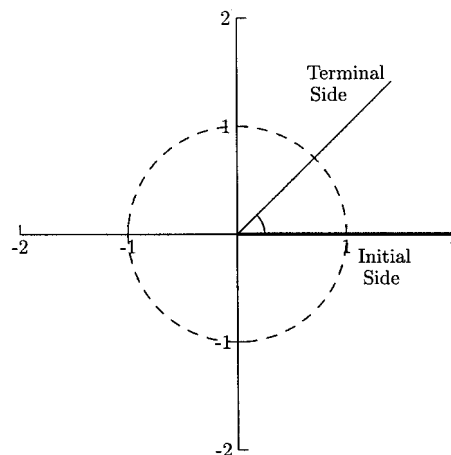

Fig. 13.2.

These equations help us to convert radian measure to degrees and degree measure to radians. We can convert radians to degrees by multiplying the angle by  $180/\pi$ . We can convert degrees to radians by multiplying the angle by  $\pi/180$ .

## EXAMPLES

- Convert  $4\pi/5$  radians to degree measure.  
Because we are going from radians to degrees, we will multiply the angle by  $180/\pi$ .

$$\frac{4\pi}{5} \cdot \frac{180}{\pi} = 144^\circ$$

- Convert  $5\pi/6$  radians to degree measure.

$$\frac{5\pi}{6} \cdot \frac{180}{\pi} = 150^\circ$$

- Convert  $48^\circ$  to radian measure.  
Because we are going from degrees to radians, we will multiply the angle by  $\pi/180$ .

$$48 \cdot \frac{\pi}{180} = \frac{4\pi}{15} \text{ radians}$$

- Convert  $-72^\circ$  to radian measure.

$$-72 \cdot \frac{\pi}{180} = -\frac{2\pi}{5}$$

Two angles are *coterminal* if their terminal sides are the same. For example, the terminal sides of the angles  $300^\circ$  and  $-60^\circ$  are the same. See Figure 13.3.

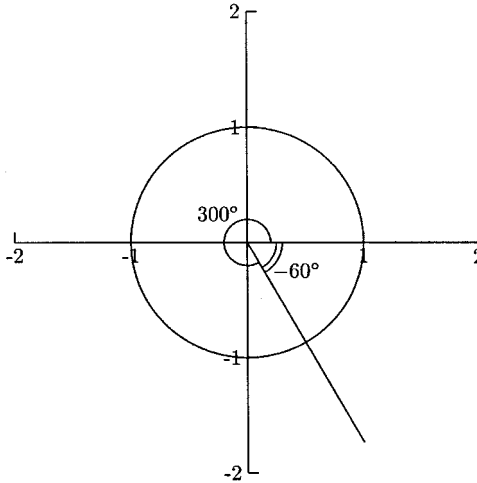

Fig. 13.3.

Two angles are coterminal if their difference is a multiple of  $360^\circ$  or  $2\pi$  radians. In the example above, the difference of  $300^\circ$  and  $-60^\circ$  is  $300^\circ - (-60^\circ) = 360^\circ$ .

## EXAMPLES

Determine whether or not the angles are coterminal.

- $18^\circ$  and  $738^\circ$   
Is the difference between  $18^\circ$  and  $738^\circ$  a multiple of  $360^\circ$ ?  $738^\circ - 18^\circ = 720^\circ$ ,  $720^\circ = 2 \cdot 360^\circ$ , so the angles are coterminal.
- $-170^\circ$  and  $350^\circ$   
 $350^\circ - (-170^\circ) = 350^\circ + 170^\circ = 520^\circ$  and  $520^\circ$  is not a multiple of  $360^\circ$ , so the angles are not coterminal.
- $\pi/8$  radians and  $-7\pi/8$  radians  
Is the difference of  $\pi/8$  and  $-7\pi/8$  a multiple of  $2\pi$ ?

$$\frac{\pi}{8} - \left(-\frac{7\pi}{8}\right) = \frac{8\pi}{8} = \pi \text{ radians}$$

Because  $\pi$  radians is not a multiple of  $2\pi$  radians, the angles are not coterminal.

Every angle,  $\theta$  (the Greek letter *theta*), has a *reference angle*,  $\bar{\theta}$ , associated with it. The reference angle is the smallest angle between the terminal side of the angle and the  $x$ -axis. A reference angle will be between  $0$  and  $\pi/2$  radians, or  $0^\circ$  and  $90^\circ$ . The reference angle for all of the angles shown in Figures 13.4 through 13.7 is  $\frac{\pi}{6}$ .

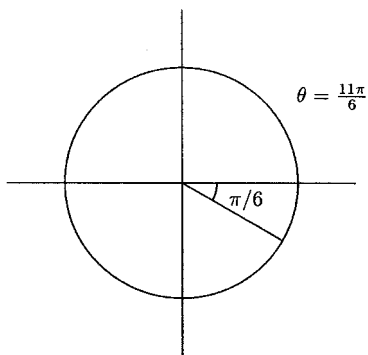

Fig. 13.4.

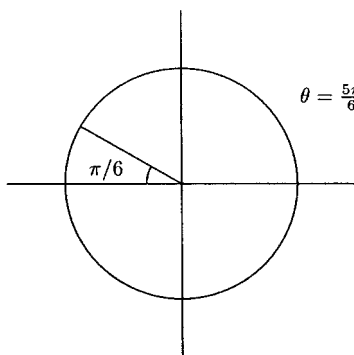

Fig. 13.5.

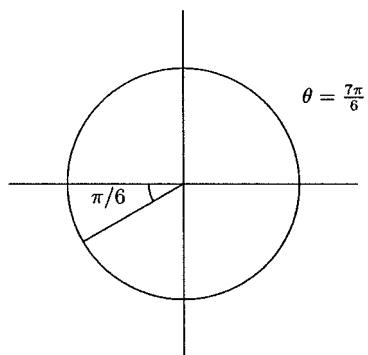

Fig. 13.6.

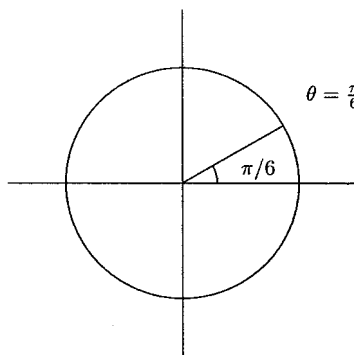

Fig. 13.7.

The  $xy$  plane is divided into four quadrants. The trigonometric functions of angles in the different quadrants will have different signs. It is important to be familiar with the signs of the trigonometric functions in the different quadrants. One reason is that formulas have  $\pm$  signs in them, and the sign of  $+$  or  $-$  depends on the quadrant in which the angle lies. Before we find reference angles, we will become familiar with the quadrants in the  $xy$  plane. (see Figure 13.8.)

## EXAMPLES

Determine the quadrant in which the point lies.

- $(5, -3)$

$x = 5$  is positive, and  $y = -3$  is negative, the point is in Quadrant IV.

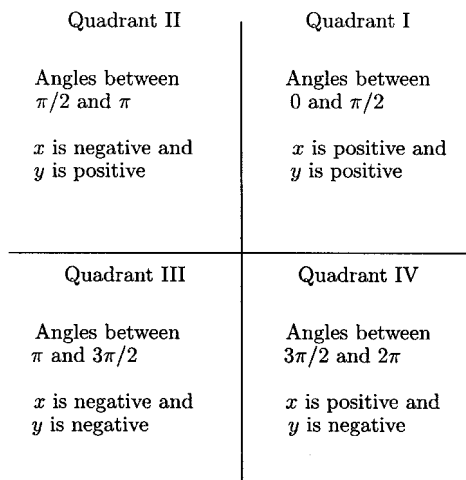

Fig. 13.8.

- $(4, 7)$   
Both  $x = 4$  and  $y = 7$  are positive, the point is in Quadrant I.
- $(-1, -6)$   
Both  $x = -1$  and  $y = -6$  are negative, the point is in Quadrant III.
- $(-2, 10)$   
 $x = -2$  is negative,  $y = 10$  is positive, the point is in Quadrant II.

Below is an outline for finding the reference angle.

1. If the angle is not between  $0$  radians and  $2\pi$  radians, find an angle between these two angles by adding or subtracting a multiple of  $2\pi$ . Call this angle  $\theta$ .
2. If  $\theta$  is in Quadrant I,  $\theta$  is its own reference angle.
3. If  $\theta$  is in Quadrant II, the reference angle is  $\pi - \theta$ .
4. If  $\theta$  is in Quadrant III, the reference angle is  $\theta - \pi$ .
5. If  $\theta$  is in Quadrant IV, the reference angle is  $2\pi - \theta$ .

## EXAMPLES

Find the reference angle.

- $\theta = \frac{9\pi}{8}$

This angle is in Quadrant III (bigger than  $\pi$  but smaller than  $3\pi/2$ ), so  $\bar{\theta} = 9\pi/8 - \pi = \pi/8$ .

- $\theta = \frac{7\pi}{3}$

This angle is not between 0 and  $2\pi$ , so we need to add or subtract some multiple of  $2\pi$  so that we do have an angle between 0 and  $2\pi$ . The coterminal angle we need is  $7\pi/3 - 2\pi = 7\pi/3 - 6\pi/3 = \pi/3$ ,  $\pi/3$  is its own reference angle because it is in Quadrant I, so  $\bar{\theta} = \pi/3$ .

- $\theta = \frac{5\pi}{7}$

This angle is in Quadrant II (between  $\pi/2$  and  $\pi$ ), so  $\bar{\theta} = \pi - 5\pi/7 = 7\pi/7 - 5\pi/7 = 2\pi/7$ .

- $\theta = -\frac{2\pi}{3}$

This angle is not between 0 and  $2\pi$ . It is coterminal with  $2\pi + (-2\pi/3) = 6\pi/3 - 2\pi/3 = 4\pi/3$ . The angles are in Quadrant III, so  $\bar{\theta} = 4\pi/3 - \pi = 4\pi/3 - 3\pi/3 = \pi/3$ .

There are six trigonometric functions, but four of them are written in terms of two of the main functions—sine and cosine. Although trigonometry was developed to solve problems involving triangles, there is a very close relationship between sine and cosine and the unit circle. Suppose an angle  $\theta$  is given. The  $x$ -coordinate of the point on the unit circle for  $\theta$  is cosine of the angle (written  $\cos \theta$ ). The  $y$ -coordinate of the point is sine of the angle (written  $\sin \theta$ ). For example, suppose the point determined by the angle  $\theta$  is  $(3/5, 4/5)$ . Then  $\cos \theta = 3/5$  and  $\sin \theta = 4/5$ . See Figure 13.9.

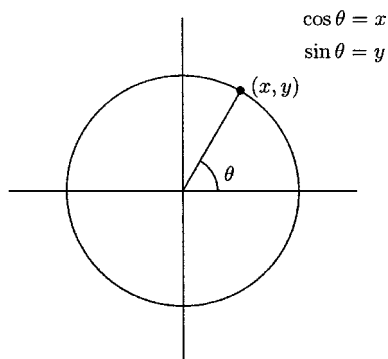

**Fig. 13.9.**

## EXAMPLES

Find  $\sin \theta$  and  $\cos \theta$ .

•

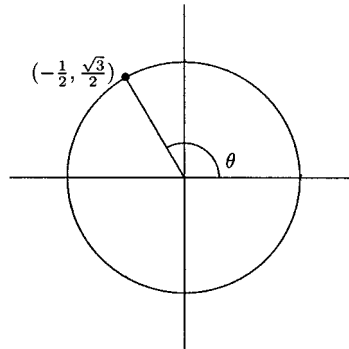

Fig. 13.10.

$$\sin \theta = \sqrt{3}/2 \text{ and } \cos \theta = -1/2$$

•

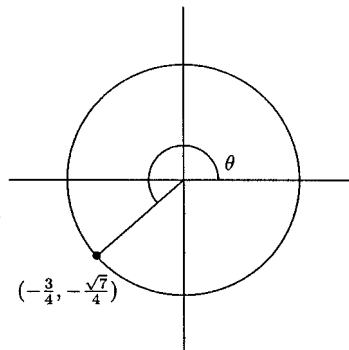

Fig. 13.11.

$$\sin \theta = -\sqrt{7}/4 \text{ and } \cos \theta = -3/4$$

The equation for the unit circle is  $x^2 + y^2 = 1$ . For an angle  $\theta$ , we can replace  $x$  with  $\cos \theta$  and  $y$  with  $\sin \theta$ . This changes the equation to  $\cos^2 \theta + \sin^2 \theta = 1$  ( $\cos^2 \theta$  means  $(\cos \theta)^2$  and  $\sin^2 \theta$  means  $(\sin \theta)^2$ ). This is an important equation. It allows us to find  $\cos \theta$  if we know  $\sin \theta$  and  $\sin \theta$  if we know  $\cos \theta$ . Solving this equation for  $\cos \theta$  gives us  $\cos \theta = \pm \sqrt{1 - \sin^2 \theta}$ . Solving it for  $\sin \theta$  gives

us  $\sin \theta = \pm\sqrt{1 - \cos^2 \theta}$ . For example, if we know  $\sin \theta = 1/2$ , we can find  $\cos \theta$ .

$$\cos \theta = \pm\sqrt{1 - \sin^2 \theta} = \pm\sqrt{1 - \left(\frac{1}{2}\right)^2} = \pm\sqrt{\frac{3}{4}} = \pm\frac{\sqrt{3}}{2}$$

Is  $\cos \theta = \sqrt{3}/2$  or  $-\sqrt{3}/2$ ? We cannot answer this without knowing where  $\theta$  is. If we know that  $\theta$  is in Quadrants I or IV, then  $\cos \theta = \sqrt{3}/2$  because cosine is positive in Quadrants I and IV. If we know that  $\theta$  is in Quadrants II or III, then  $\cos \theta = -\sqrt{3}/2$  because cosine is negative in Quadrants II and III.

## EXAMPLES

Find  $\sin \theta$  and  $\cos \theta$ .

- The terminal point for  $\theta$  is  $(-12/13, y)$ , and  $\theta$  is in Quadrant II.

$$\cos \theta = -12/13$$

$$\text{Is } \sin \theta = \sqrt{1 - \left(-\frac{12}{13}\right)^2} \quad \text{or} \quad -\sqrt{1 - \left(-\frac{12}{13}\right)^2} \quad ?$$

Because the  $y$ -values in Quadrant II are positive,  $\sin \theta$  is positive.

$$\sin \theta = \sqrt{1 - \left(-\frac{12}{13}\right)^2} = \sqrt{\frac{25}{169}} = \frac{5}{13}$$

- The terminal point for  $\theta$  is  $(x, -1/9)$ , and  $\theta$  is in Quadrant III.

Both sine and cosine are negative in Quadrant III, so we will use the negative square root. Using  $\sin \theta = -1/9$ , we have

$$\cos \theta = -\sqrt{1 - \left(-\frac{1}{9}\right)^2} = -\sqrt{\frac{80}{81}} = -\frac{4\sqrt{5}}{9}$$

The values for sine and cosine of the following angles should be memorized:  $0$ ,  $\pi/6$ ,  $\pi/4$ ,  $\pi/3$ , and  $\pi/2$ . See Figure 13.12.



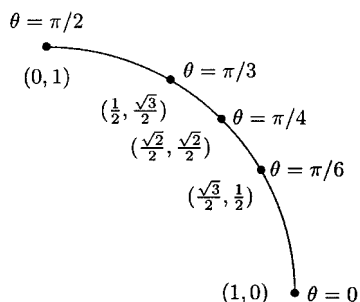

Fig. 13.12.

All of these angles are also reference angles in the other three quadrants. You should either memorize or be able to quickly compute them. The information is in the table below.

Table 13.1

	$\theta$	$\cos \theta$	$\sin \theta$		$\theta$	$\cos \theta$	$\sin \theta$
	0	1	0		$\pi$	-1	0
Quadrant I	$\frac{\pi}{6}$	$\frac{\sqrt{3}}{2}$	$\frac{1}{2}$	Quadrant III	$\pi + \frac{\pi}{6} = \frac{7\pi}{6}$	$-\frac{\sqrt{3}}{2}$	$-\frac{1}{2}$
Quadrant I	$\frac{\pi}{4}$	$\frac{\sqrt{2}}{2}$	$\frac{\sqrt{2}}{2}$	Quadrant III	$\pi + \frac{\pi}{4} = \frac{5\pi}{4}$	$-\frac{\sqrt{2}}{2}$	$-\frac{\sqrt{2}}{2}$
Quadrant I	$\frac{\pi}{3}$	$\frac{1}{2}$	$\frac{\sqrt{3}}{2}$	Quadrant III	$\pi + \frac{\pi}{3} = \frac{4\pi}{3}$	$-\frac{1}{2}$	$-\frac{\sqrt{3}}{2}$
	$\frac{\pi}{2}$	0	1		$\frac{3\pi}{2}$	0	-1
Quadrant II	$\pi - \frac{\pi}{3} = \frac{2\pi}{3}$	$-\frac{1}{2}$	$\frac{\sqrt{3}}{2}$	Quadrant IV	$2\pi - \frac{\pi}{3} = \frac{5\pi}{3}$	$\frac{1}{2}$	$-\frac{\sqrt{3}}{2}$
Quadrant II	$\pi - \frac{\pi}{4} = \frac{3\pi}{4}$	$-\frac{\sqrt{2}}{2}$	$\frac{\sqrt{2}}{2}$	Quadrant IV	$2\pi - \frac{\pi}{4} = \frac{7\pi}{4}$	$\frac{\sqrt{2}}{2}$	$-\frac{\sqrt{2}}{2}$
Quadrant II	$\pi - \frac{\pi}{6} = \frac{5\pi}{6}$	$-\frac{\sqrt{3}}{2}$	$\frac{1}{2}$	Quadrant IV	$2\pi - \frac{\pi}{6} = \frac{11\pi}{6}$	$\frac{\sqrt{3}}{2}$	$-\frac{1}{2}$

The other trigonometric functions are tangent (tan), cotangent (cot), secant (sec), and cosecant (csc). All of them can be written as a ratio with sine, cosine, or both.

$$\tan \theta = \frac{\sin \theta}{\cos \theta} = \frac{y}{x} \quad \cot \theta = \frac{\cos \theta}{\sin \theta} = \frac{x}{y}$$

$$\sec \theta = \frac{1}{\cos \theta} = \frac{1}{x} \quad \csc \theta = \frac{1}{\sin \theta} = \frac{1}{y}$$

Sine and cosine can be evaluated at any angle. This is not true for the other trigonometric functions. For example  $\tan \pi/2 = \sin \pi/2 / \cos \pi/2$  and  $\sec \pi/2 = 1 / \cos \pi/2$  are not defined because  $\cos \pi/2 = 0$ . We can find all six trigonometric functions for an angle  $\theta$  if we either know both coordinates of its terminal point or if we know one coordinate and the quadrant where  $\theta$  lies.

Before we begin the next set of problems, we will review a shortcut that will save some computation for  $\tan \theta$ . A compound fraction of the form  $(a/b)/(c/b)$  simplifies to  $a/c$ .

$$\frac{a/b}{c/b} = \frac{a}{b} \div \frac{c}{b} = \frac{a}{b} \cdot \frac{b}{c} = \frac{a}{c}$$

## EXAMPLES

- $\frac{1/8}{5/8} = \frac{1}{5}$
- $\frac{4/7}{2/7} = \frac{4}{2} = 2$
- $\frac{-2/3}{1/3} = -\frac{2}{1} = -2$
- $\frac{1/9}{-5/9} = -\frac{1}{5}$

Find all six trigonometric functions for  $\theta$ .

- The terminal point for  $\theta$  is  $(24/25, 7/25)$

$$\begin{aligned} \cos \theta &= \frac{24}{25} & \sin \theta &= \frac{7}{25} \\ \sec \theta &= \frac{25}{24} & \csc \theta &= \frac{25}{7} \\ \tan \theta &= \frac{7/25}{24/25} = \frac{7}{24} & \cot \theta &= \frac{24}{7} \end{aligned}$$

- $\theta = \pi/3$

$$\begin{aligned} \cos \theta &= \frac{1}{2} & \sin \theta &= \frac{\sqrt{3}}{2} \\ \sec \theta &= 2 & \csc \theta &= \frac{2}{\sqrt{3}} = \frac{2\sqrt{3}}{3} \\ \tan \theta &= \frac{\sqrt{3}/2}{1/2} = \frac{\sqrt{3}}{1} = \sqrt{3} & \cot \theta &= \frac{1}{\sqrt{3}} = \frac{\sqrt{3}}{3} \end{aligned}$$

- $\theta = 5\pi/6$

$$\begin{aligned} \cos \theta &= -\frac{\sqrt{3}}{2} & \sin \theta &= \frac{1}{2} \\ \sec \theta &= -\frac{2}{\sqrt{3}} = -\frac{2\sqrt{3}}{3} & \csc \theta &= 2 \\ \tan \theta &= \frac{1/2}{-\sqrt{3}/2} = -\frac{1}{\sqrt{3}} = -\frac{\sqrt{3}}{3} & \cot \theta &= -\sqrt{3} \end{aligned}$$

- The  $x$ -coordinate of  $\theta$  is  $2/5$ , and  $\theta$  is in Quadrant IV.

$$\begin{aligned} \cos \theta &= \frac{2}{5} & \sin \theta &= -\sqrt{1 - \left(\frac{2}{5}\right)^2} = -\frac{\sqrt{21}}{5} \\ \sec \theta &= \frac{5}{2} & \csc \theta &= -\frac{5}{\sqrt{21}} = -\frac{5\sqrt{21}}{21} \\ \tan \theta &= \frac{-\sqrt{21}/5}{2/5} = -\frac{\sqrt{21}}{2} & \cot \theta &= -\frac{2}{\sqrt{21}} = -\frac{2\sqrt{21}}{21} \end{aligned}$$

The graph of a trigonometric function is a record of each cycle around the unit circle. For the function  $f(x) = \sin x$ ,  $x$  is the angle and  $f(x)$  is the  $y$ -coordinate of the terminal point determined by the angle  $x$ . In the function  $g(x) = \cos x$ ,  $g(x)$  is the  $x$ -coordinate of the terminal point determined by the angle  $x$ . For example, the point determined by the angle  $\pi/6$  is  $(\sqrt{3}/2, 1/2)$ , so  $f(\pi/6) = \sin \pi/6 = 1/2$  and  $g(\pi/6) = \cos \pi/6 = \sqrt{3}/2$ . We will sketch the graph of  $f(x) = \sin x$ , using the points in Table 13.2.

Table 13.2

$x$	$\sin x$	Plot this point
$-2\pi$	$\sin(-2\pi) = 0$	$(-2\pi, 0)$
$-3\pi/2$	$\sin(-3\pi/2) = 1$	$(-3\pi/2, 1)$
$-\pi$	$\sin(-\pi) = 0$	$(-\pi, 0)$
$-\pi/2$	$\sin(-\pi/2) = -1$	$(-\pi/2, -1)$
$0$	$\sin 0 = 0$	$(0, 0)$
$\pi/2$	$\sin \pi/2 = 1$	$(\pi/2, 1)$
$\pi$	$\sin \pi = 0$	$(\pi, 0)$
$3\pi/2$	$\sin 3\pi/2 = -1$	$(3\pi/2, -1)$
$2\pi$	$\sin 2\pi = 0$	$(2\pi, 0)$

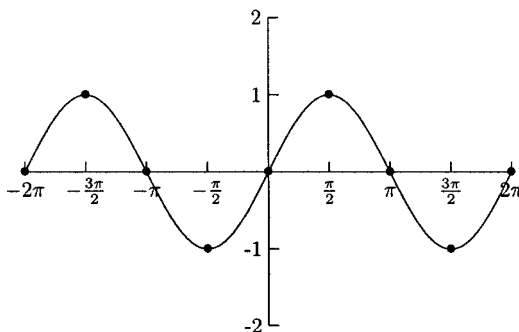

Fig. 13.13.

The graph in Figure 13.13 is two *periods* from the entire graph. This pattern repeats itself in both directions. Each period begins and ends at every multiple of  $2\pi$ :  $\dots$ ,  $[-2\pi, 0]$ ,  $[0, 2\pi]$ ,  $[2\pi, 4\pi]$ ,  $\dots$ . The graph between 0 and  $2\pi$  represents sine on the first positive cycle around the unit circle, between  $2\pi$  and  $4\pi$  represents the second positive cycle, and between 0 and  $-2\pi$  represents the first negative cycle.

The graph for  $g(x) = \cos x$  behaves in the same way. In fact, the graph of  $g(x)$  is the graph of  $f(x)$  shifted horizontally  $\pi/2$  units. (We will see why this is true when we work with right triangles.) The graph for  $g(x) = \cos x$  is shown in Figure 13.14.

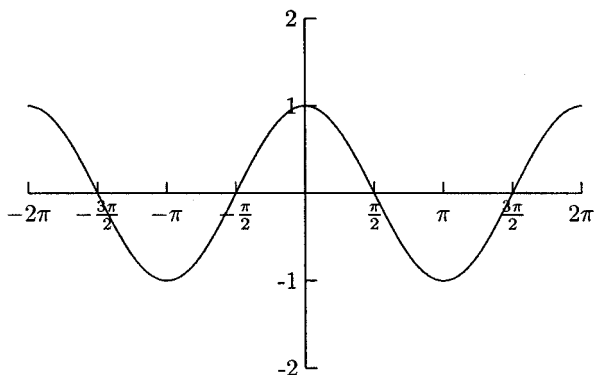

Fig. 13.14.

From their graphs, we can tell that  $f(x) = \sin x$  is an odd function ( $\sin(-x) = -\sin x$ ), and  $g(x) = \cos x$  is even ( $\cos(-x) = \cos x$ ). We can also see that their domain is all  $x$  and their range is all  $y$  values between  $-1$  and  $1$ .

The graphs of  $f(x) = \sin x$  and  $g(x) = \cos x$  can be shifted up or down, left or right, and stretched or compressed in the same way as other graphs. The graphs

of  $y = c + \sin x$  and  $y = c + \cos x$  are shifted up or down  $c$  units. The graphs of  $y = a \sin x$  and  $y = a \cos x$  are vertically stretched or compressed, and the graphs of  $y = \sin(x - b)$  and  $y = \cos(x - b)$  are shifted horizontally by  $b$  units.

**EXAMPLES**

The dashed graph in Figures 13.15 through 13.18 is one period of the graph of  $f(x) = \sin x$ , and the solid graphs are transformations. Match the equations below with their graphs.

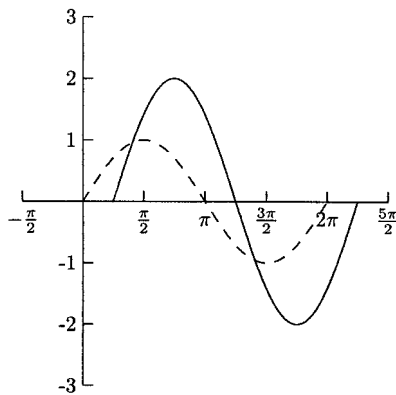

Fig. 13.15.

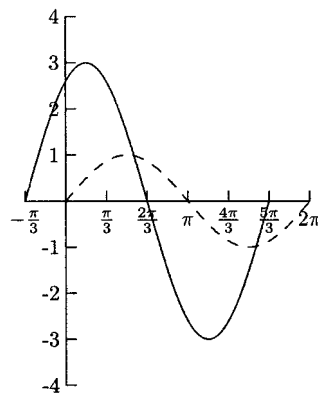

Fig. 13.16.

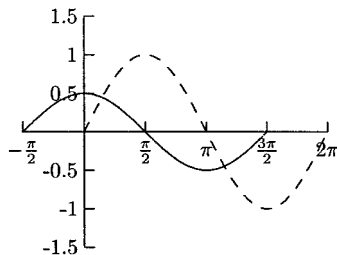

Fig. 13.17.

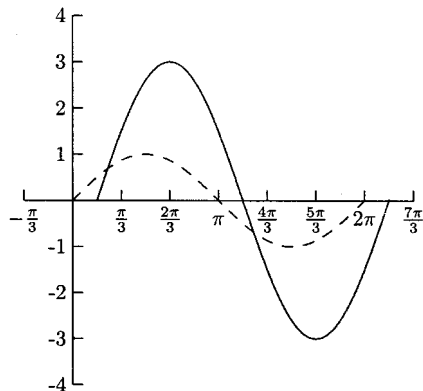

Fig. 13.18.

- $y = 3 \sin(x + \pi/3)$

The graph of this function is vertically stretched by a factor of 3, so we will look for a graph whose  $y$  values lie between  $-3$  and  $3$ . The graph will also be shifted to the left by  $\pi/3$  units. The graph for this function is shown in Figure 13.16.

- $y = 3 \sin(x - \pi/6)$

The graph of this function is also vertically stretched by a factor of three, but it is shifted to the right by  $\pi/6$  units. The graph for this function is shown in Figure 13.18.

- $y = \frac{1}{2} \sin(x + \pi/2)$

The graph of this function is vertically compressed by a factor of  $1/2$ , so we will look for a graph whose  $y$  values are between  $-1/2$  and  $1/2$ . The graph will also be shifted to the left by  $\pi/2$  units. The graph for this function is shown in Figure 13.17.

- $y = 2 \sin(x - \pi/4)$

The graph of this function is vertically stretched by a factor of 2, so we will look for a graph whose  $y$  values are between  $-2$  and  $2$ . It will also be shifted to the right  $\pi/4$  units. The graph for this function is shown in Figure 13.15.

Transformations of the graphs of sine and cosine have names. The *amplitude* is the degree of vertical stretching or compressing. The horizontal shift is called the *phase shift*. Horizontal stretching or compressing changes the length of the period. For functions of the form  $y = a \sin k(x - b)$  and  $y = a \cos k(x - b)$ ,  $|a|$  is the graph's amplitude,  $b$  is its phase shift, and  $2\pi/k$  is its period.

## EXAMPLES

Find the amplitude, period, and phase shift.

- $y = -4 \sin 2(x - \pi/3)$

The amplitude is  $|a| = |-4| = 4$ , the period is  $2\pi/k = 2\pi/2 = \pi$ , and the phase shift is  $b = \pi/3$ .

- $y = -\cos(x + \pi/2)$

The amplitude is  $|a| = |-1| = 1$ , the period is  $2\pi/k = 2\pi/1 = 2\pi$ , and the phase shift is  $b = -\pi/2$ .

- $y = \frac{1}{2} \cos(2x + 2\pi/3)$

The amplitude is  $|1/2| = 1/2$ . In order for us to find  $k$  and  $b$  for the period and phase shift, we need to write the function in the form  $y = a \cos k(x - b)$ . We need to factor 2 from  $2x + 2\pi/3$ .

$$2x + \frac{2\pi}{3} = 2 \cdot x + 2 \cdot \frac{\pi}{3} = 2 \left( x + \frac{\pi}{3} \right)$$

The function can be written as  $y = \frac{1}{2} \cos 2(x + \pi/3)$ . The period is  $2\pi/k = 2\pi/2 = \pi$ , and the phase shift is  $k = -\pi/3$ .

## Sketching the Graphs of Sine and Cosine

We can sketch one period of the graphs of sine and cosine or any of their transformations by plotting five key points. These points for  $y = \sin x$  and  $y = \cos x$  are  $x = 0, \pi/2, \pi, 3\pi/2$  and  $2\pi$ . These points are the  $x$ -intercepts and the vertices (where  $y = 1$  or  $-1$ ). For the functions  $y = a \sin k(x - b)$  and  $y = a \cos k(x - b)$ , these points are shifted to  $b, b + \frac{\pi}{2k}, b + \frac{\pi}{k}, b + \frac{3\pi}{2k},$  and  $b + \frac{2\pi}{k}$ .

## EXAMPLES

Sketch one period of the graph for the given function.

- $y = -3 \cos \frac{1}{2}x$

Table 13.3

$x$	$-3 \cos \frac{1}{2}x$	Plot this point
$b = 0$	$-3 \cos \frac{1}{2}(0) = -3 \cos 0 = -3$	$(0, -3)$
$b + \frac{\pi}{2k} = 0 + \frac{\pi}{2(\frac{1}{2})} = 0 + \pi = \pi$	$-3 \cos \frac{1}{2}(\pi) = -3 \cos \pi/2 = 0$	$(\pi, 0)$
$b + \frac{\pi}{k} = 0 + \frac{\pi}{1/2} = 0 + 2\pi = 2\pi$	$-3 \cos \frac{1}{2}(2\pi) = -3 \cos \pi = 3$	$(2\pi, 3)$
$b + \frac{3\pi}{2k} = 0 + \frac{3\pi}{2(\frac{1}{2})} = 0 + 3\pi = 3\pi$	$-3 \cos \frac{1}{2}(3\pi) = -3 \cos 3\pi/2 = 0$	$(3\pi, 0)$
$b + \frac{2\pi}{k} = 0 + \frac{2\pi}{1/2} = 0 + 4\pi = 4\pi$	$-3 \cos \frac{1}{2}(4\pi) = -3 \cos 2\pi = -3$	$(4\pi, -3)$

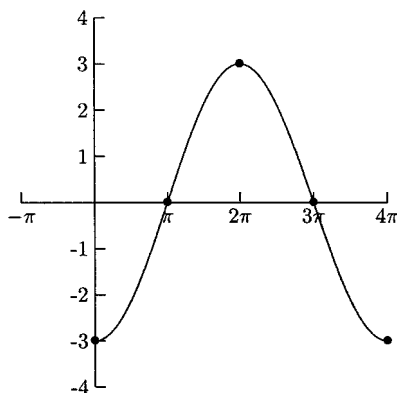

Fig. 13.19.

- $y = 5 \sin(3x + \pi/2)$

We need to write the function in the form  $y = a \sin k(x - b)$  so that we can find  $k$  and  $b$ .

$$3x + \frac{\pi}{2} = 3x + \frac{3}{3} \cdot \frac{\pi}{2} = 3 \cdot x + 3 \cdot \frac{\pi}{6} = 3 \left( x + \frac{\pi}{6} \right)$$

Table 13.4

$x$	$5 \sin 3(x + \pi/6)$	Plot this point
$b = -\pi/6$	$5 \sin 3(-\pi/6 + \pi/6) = 5 \sin 0 = 0$	$(-\pi/6, 0)$
$b + \frac{\pi}{2k} = -\frac{\pi}{6} + \frac{\pi}{2(3)} = 0$	$5 \sin 3(0 + \pi/6) = 5 \sin \pi/2 = 5$	$(0, 5)$
$b + \frac{\pi}{k} = -\frac{\pi}{6} + \frac{\pi}{3} = \pi/6$	$5 \sin 3(\pi/6 + \pi/6) = 5 \sin \pi = 0$	$(\pi/6, 0)$
$b + \frac{3\pi}{2k} = -\frac{\pi}{6} + \frac{3\pi}{2(3)} = \pi/3$	$5 \sin 3(\pi/3 + \pi/6) = 5 \sin 3\pi/2 = -5$	$(\pi/3, -5)$
$b + \frac{2\pi}{k} = -\frac{\pi}{6} + \frac{2\pi}{3} = \pi/2$	$5 \sin 3(\pi/2 + \pi/6) = 5 \sin 2\pi = 0$	$(\pi/2, 0)$

The points in Table 13.4 are used to construct the graph in Figure 13.20.

## PRACTICE

For Problems 1–3, match the function with its graph shown in Figures 13.21–13.23. The dashed graph is the graph of one period of  $y = \cos x$ . The solid graph is the graph of one period of a transformation.



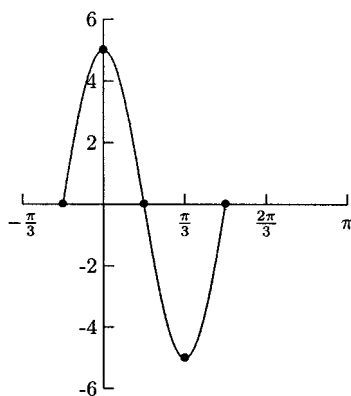

Fig. 13.20.

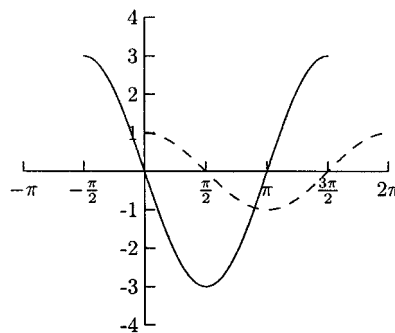

Fig. 13.21.

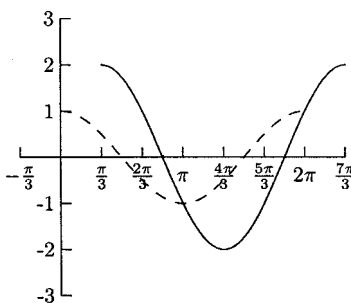

Fig. 13.22.

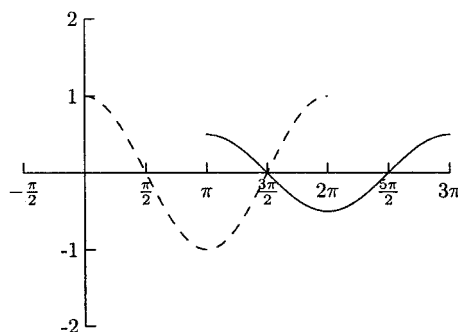

Fig. 13.23.

- $y = 2 \cos(x - \pi/3)$
- $y = 3 \cos(x + \pi/2)$
- $y = \frac{1}{2} \cos(x - \pi)$
- Find the amplitude, period, and phase shift for  $y = -3 \cos \frac{2}{3}(x - \pi/4)$ .
- Find the amplitude, period, and phase shift for  $y = 6 \sin(2x - \pi/2)$ .
- Sketch one period for the graph of  $y = 3 \cos \frac{1}{2}(x + \pi/4)$ .
- Sketch one period for the graph of  $y = -1 + 2 \sin(x - \pi/3)$

## SOLUTIONS

- Figure 13.22
- Figure 13.21

3. Figure 13.23
4. The amplitude is  $|-3| = 3$ , the period is  $\frac{2\pi}{2/3} = 2\pi \cdot 3/2 = 3\pi$ , and the phase shift is  $b = \pi/4$ .
5. In order to find  $k$  and  $b$ , we need to write the function in the form  $y = a \sin k(x - b)$ .

$$2x - \frac{\pi}{2} = 2x - \frac{2}{2} \cdot \frac{\pi}{2} = 2 \cdot x - 2 \cdot \frac{\pi}{4} = 2 \left( x - \frac{\pi}{4} \right)$$

The function can be written as  $y = 6 \sin 2(x - \pi/4)$ . Now we can see that the amplitude is  $|6| = 6$ , the period is  $2\pi/2 = \pi$ , and the phase shift is  $\pi/4$ .

6. Plot points for  $x = -\pi/4, 3\pi/4, 7\pi/4, 11\pi/4$ , and  $15\pi/4$ .

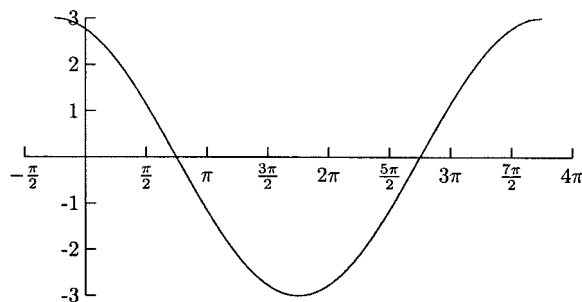

Fig. 13.24.

7. Plot points for  $x = \pi/3, 5\pi/6, 4\pi/3, 11\pi/6$ , and  $7\pi/3$ .

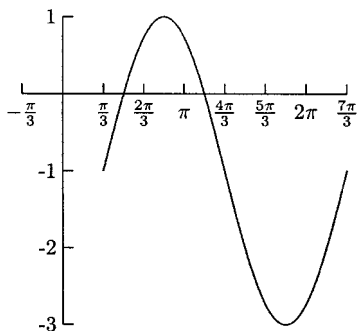

Fig. 13.25.

### Graphs for Other Trigonometric Functions

Because  $\csc x = 1/\sin x$ , the graph of  $y = \csc x$  has a vertical asymptote everywhere  $y = \sin x$  has an  $x$ -intercept (where  $\sin x = 0$ ). Because  $\sec x = 1/\cos x$ , the graph of  $y = \sec x$  has a vertical asymptote everywhere  $y = \cos x$  has an  $x$ -intercept. The period for  $y = \csc x$  and  $y = \sec x$  is  $2\pi$ . The graph for  $y = \csc x$  is shown in Figure 13.26, and the graph for  $y = \sec x$  is shown in Figure 13.27.

The domain for  $y = \csc x$  is all real numbers except for the zeros of  $\sin x$ ,  $x \neq \dots, -2\pi, -\pi, 0, \pi, 2\pi, \dots$ . The range is  $(-\infty, -1] \cup [1, \infty)$ . The domain for  $y = \sec x$  is all real numbers except for the zeros of  $\cos x$ ,  $x \neq \dots, -3\pi/2, -\pi/2, \pi/2, 3\pi/2, \dots$ . The range is  $(-\infty, -1] \cup [1, \infty)$ . Because

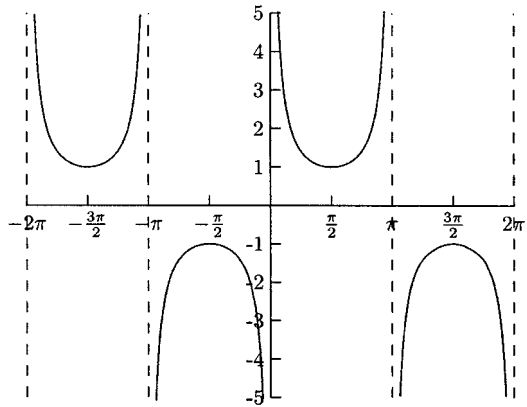

Fig. 13.26.

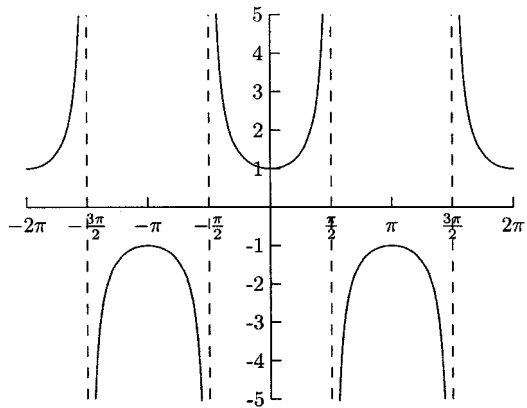

Fig. 13.27.

$y = \sin x$  is an odd function,  $y = \csc x$  is also an odd function. Because  $y = \cos x$  is an even function,  $y = \sec x$  is also an even function.

We can sketch the graphs of  $y = \csc x$  and  $y = \sec x$  using the graphs of  $y = \sin x$  and  $y = \cos x$ . We will sketch the vertical asymptotes as well as the graphs of  $y = \sin x$  or  $y = \cos x$  using dashed graphs.

The graph of  $y = \sin x$  is given in Figure 13.28. Vertical asymptotes are sketched for every  $x$ -intercept.

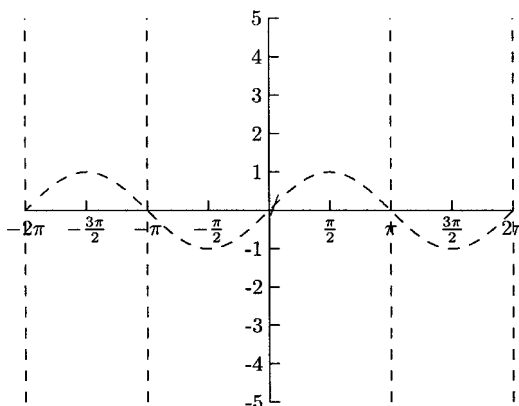

Fig. 13.28.

The vertex for each piece on the graph of  $y = \csc x$  is also a vertex for  $y = \sin x$ .

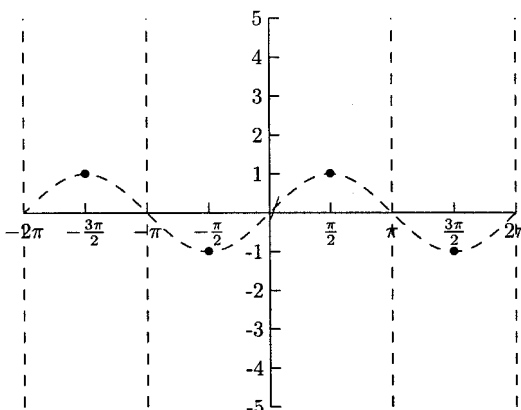

Fig. 13.29.

Then we can plot a point to the left and right of each vertex (staying inside the vertical asymptotes) to show how fast the graph gets close to the vertical asymptotes.

Table 13.5

$x$	$\csc x$
$-1.8\pi$	1.7
$-1.2\pi$	1.7
$-0.8\pi$	-1.7
$-0.2\pi$	-1.7
$0.2\pi$	1.7
$0.8\pi$	1.7
$1.2\pi$	-1.7
$1.8\pi$	-1.7

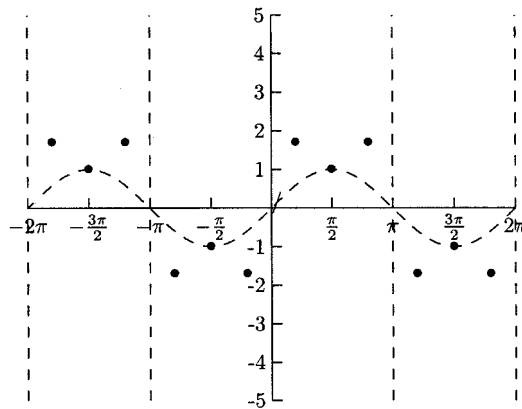

Fig. 13.30.

Now we can draw  $\cup$  or  $\cap$  through the points.

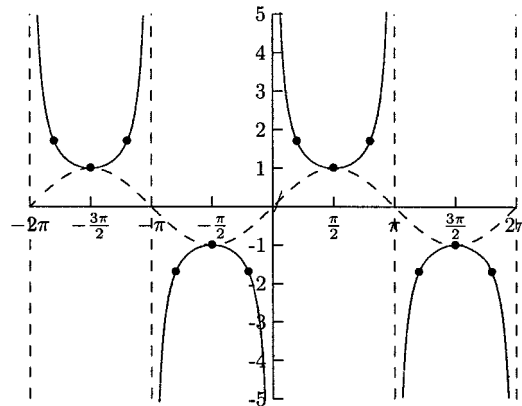

Fig. 13.31.

These steps also work for the graph of  $y = \sec x$ .

The period for the functions  $y = \tan x$  and  $y = \cot x$  is  $\pi$  instead of  $2\pi$  as it is with the other trigonometric functions. These graphs also have vertical asymptotes. The graph of  $y = \tan x$  ( $= \sin x / \cos x$ ) has a vertical asymptote at each zero of  $y = \cos x$ . The graph of  $y = \cot x$  ( $= \cos x / \sin x$ ) has a vertical asymptote at each zero of  $y = \sin x$ . The graph of  $y = \tan x$  is shown in Figure 13.32, and the graph of  $y = \cot x$  is shown in Figure 13.33.

The domain of  $y = \tan x$  is all real numbers except the zeros of  $y = \cos x$ ,  $x \neq \dots, -3\pi/2, -\pi/2, \pi/2, 3\pi/2, \dots$ . The domain for  $y = \cot x$  is all real numbers except for the zeros of  $y = \sin x$ ,  $x \neq \dots, -2\pi, -\pi, 0, \pi, 2\pi, \dots$ . The range for both  $y = \tan x$  and  $y = \cot x$  is all real numbers. Both are odd functions.

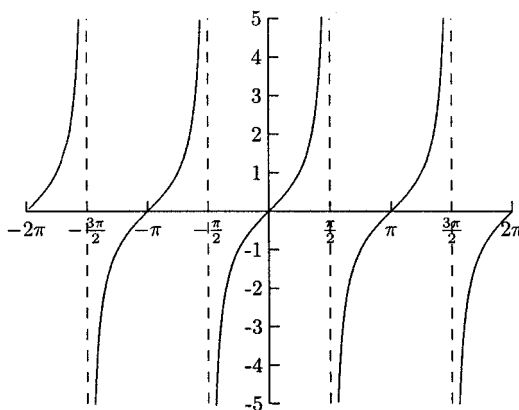

Fig. 13.32.

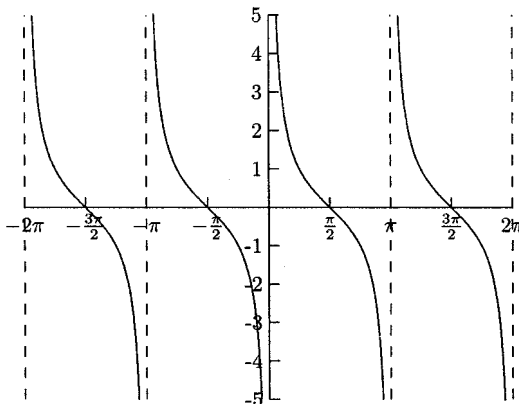

Fig. 13.33.

The transformations of these are similar to those of the other trigonometric functions. For functions of the form  $y = a \csc k(x - b)$  and  $y = a \sec k(x - b)$ , the period is  $2\pi/k$ , and the phase shift is  $b$ . For functions of the form  $y = a \tan k(x - b)$  and  $y = a \cot k(x - b)$ , the period is  $\pi/k$ , and the phase shift is  $b$ . The term *amplitude* only applies to the sine and cosine functions.

## Right Triangle Trigonometry

Using trigonometry to solve triangles is one of the oldest forms of mathematics. One of its most powerful uses is to measure distances—the height of a tree or building, the distance between earth and the moon, or the dimensions of a plot of land. The trigonometric ratios below are the same as before with the unit circle, only the labels are different. We will begin with right triangles.

In a right triangle, one angle measures  $90^\circ$  and the sum of the other angles is also  $90^\circ$ . The side opposite the  $90^\circ$  angle is the *hypotenuse*. The other sides are the *legs*. If we let  $\theta$  represent one of the acute angles, then one of the legs is the side opposite  $\theta$ , and the other side is adjacent to  $\theta$ . See Figure 13.34.

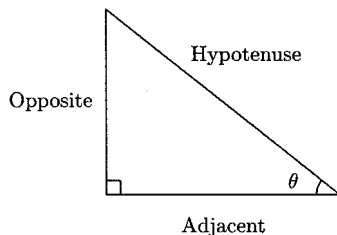

Fig. 13.34.

$$\begin{array}{lll} \sin \theta = \frac{\text{Opposite}}{\text{Hypotenuse}} & \cos \theta = \frac{\text{Adjacent}}{\text{Hypotenuse}} & \tan \theta = \frac{\text{Opposite}}{\text{Adjacent}} \\ \csc \theta = \frac{\text{Hypotenuse}}{\text{Opposite}} & \sec \theta = \frac{\text{Hypotenuse}}{\text{Adjacent}} & \cot \theta = \frac{\text{Adjacent}}{\text{Opposite}} \end{array}$$

We can get the identity  $\sin^2 \theta + \cos^2 \theta = 1$  from the Pythagorean Theorem.  
 $\text{Opposite}^2 + \text{Adjacent}^2 = \text{Hypotenuse}^2$   
 Divide both sides by  $\text{Hypotenuse}^2$ .

$$\left( \frac{\text{Opposite}}{\text{Hypotenuse}} \right)^2 + \left( \frac{\text{Adjacent}}{\text{Hypotenuse}} \right)^2 = \left( \frac{\text{Hypotenuse}}{\text{Hypotenuse}} \right)^2$$

$$\sin^2 \theta + \cos^2 \theta = 1$$

From this equation, we get two others, one from dividing both sides of the equation by  $\sin^2 \theta$ , and the other by dividing both sides by  $\cos^2 \theta$ .

$$\left(\frac{\sin \theta}{\sin \theta}\right)^2 + \left(\frac{\cos \theta}{\sin \theta}\right)^2 = \left(\frac{1}{\sin \theta}\right)^2$$

$$1 + \cot^2 \theta = \csc^2 \theta$$

$$\left(\frac{\sin \theta}{\cos \theta}\right)^2 + \left(\frac{\cos \theta}{\cos \theta}\right)^2 = \left(\frac{1}{\cos \theta}\right)^2$$

$$\tan^2 \theta + 1 = \sec^2 \theta$$

## EXAMPLES

- Find all six trigonometric ratios for  $\theta$ .

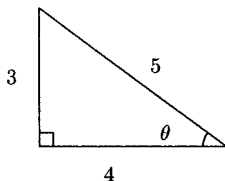

Fig. 13.35.

$$\sin \theta = \frac{\text{Opposite}}{\text{Hypotenuse}} = \frac{3}{5} \qquad \cos \theta = \frac{\text{Adjacent}}{\text{Hypotenuse}} = \frac{4}{5}$$

$$\tan \theta = \frac{\text{Opposite}}{\text{Adjacent}} = \frac{3}{4}$$

$$\csc \theta = \frac{\text{Hypotenuse}}{\text{Opposite}} = \frac{5}{3} \qquad \sec \theta = \frac{\text{Hypotenuse}}{\text{Adjacent}} = \frac{5}{4}$$

$$\cot \theta = \frac{\text{Adjacent}}{\text{Opposite}} = \frac{4}{3}$$

- Find  $\sin A$ ,  $\cos B$ ,  $\sec A$ ,  $\csc B$ ,  $\tan A$ , and  $\cot B$ .

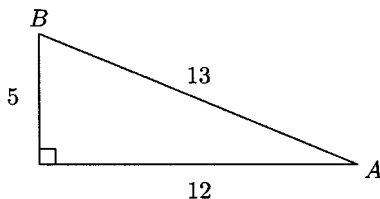

Fig. 13.36.



The hypotenuse is 13, the side opposite  $\angle A$  is 5, so  $\sin A = 5/13$ . The side adjacent to  $\angle B$  is 5, so  $\cos B = 5/13$ . The other ratios are  $\sec A = 13/12$ ,  $\csc B = 13/12$ ,  $\tan A = 5/12$ , and  $\cot B = 5/12$ .

The side opposite  $\angle A$  is the side adjacent to  $\angle B$ , and the side adjacent to  $\angle A$  is opposite  $\angle B$ . This is why sine and cosine, secant and cosecant, and tangent and cotangent are co-functions. Because  $\angle A + \angle B = 90^\circ$ , we have  $\angle B = 90^\circ - \angle A$ . These facts give us the following important relationships.

$$\sin A = \cos B = \cos(90^\circ - A) \quad \cos A = \sin B = \sin(90^\circ - A)$$

$$\tan A = \cot B = \cot(90^\circ - A)$$

$$\csc A = \sec B = \sec(90^\circ - A) \quad \sec A = \csc B = \csc(90^\circ - A)$$

$$\cot A = \tan B = \tan(90^\circ - A)$$

To “solve a triangle” means to find all three angles and the lengths of all three sides. For now, we will solve right triangles. Later, after covering inverse trigonometric functions, we can solve other triangles. When solving right triangles, we will use the Pythagorean Theorem as well as the fact that the sum of the two acute angles is  $90^\circ$ . Except for the angles  $30^\circ$ ,  $45^\circ$ , and  $60^\circ$ , we need a calculator. The calculator should be in degree mode. Also, there are probably no keys for secant, cosecant, and cotangent. You will need to use the reciprocal key, marked either  $\frac{1}{x}$  or  $x^{-1}$ . The keys marked  $\sin^{-1}$ ,  $\cos^{-1}$ , and  $\tan^{-1}$  are used to evaluate the functions covered in the next section.

## EXAMPLES

- Solve the triangle.

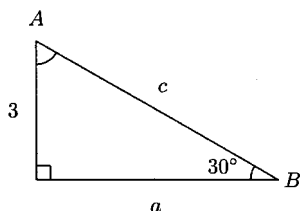

Fig. 13.37.

The side opposite the angle  $30^\circ$  is 3, so  $\sin 30^\circ = \frac{3}{c}$ . We know that  $\sin 30^\circ = 1/2$ . This gives us an equation to solve.

$$\frac{1}{2} = \frac{3}{c}$$

$$c = 6$$

We could use trigonometry to find the third side, but it is usually easier to use the Pythagorean Theorem.

$$a^2 + 3^2 = 6^2$$

$$a^2 = 36 - 9 = 27$$

$$a = \sqrt{27} = 3\sqrt{3}$$

$$A = 90^\circ - B = 90^\circ - 30^\circ = 60^\circ.$$

In some applications of right triangles, we are given the angle of *elevation* or *depression* to an object. The angle of elevation is the measure of upward rotation. The angle of depression is the measure of the downward rotation. See Figure 13.38.

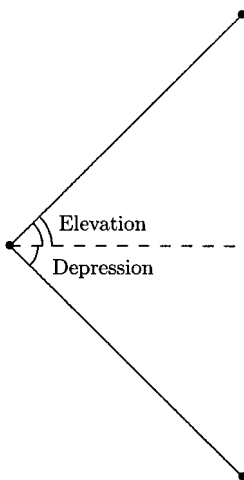

Fig. 13.38.

- A person is standing 300 feet from the base of a five-story building. He estimates that the angle of elevation to the top of the building is  $63^\circ$ . Approximately how tall is the building?

We need to find  $b$  in the following triangle.

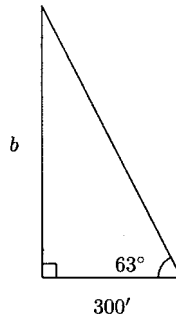

Fig. 13.39.

We could use either of the ratios that use the opposite and adjacent sides, tangent (opposite/adjacent) and cotangent (adjacent/opposite). We will use tangent.

$$\tan 63^\circ = \frac{\text{Opposite}}{\text{Adjacent}} = \frac{b}{300}$$

This gives us the equation  $\tan 63^\circ = b/300$ . When we solve for  $b$ , we have  $b = 300 \tan 63^\circ \approx (300)1.9626 \approx 588.78$ . The building is about 589 feet tall.

- A guy wire is 60 feet from the base of a tower. The angle of elevation from the top of the tower along the wire is  $73^\circ$ . How long is the wire?

We need to find  $c$  in the following triangle.

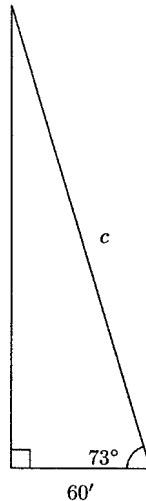

Fig. 13.40.

We could use either cosine (adjacent/hypotenuse) or secant (hypotenuse/adjacent). Using cosine, we have  $\cos 73^\circ = 60/c$ . Solving this equation for  $c$  gives us  $c = 60/\cos 73^\circ \approx 60/0.2924 \approx 205$ . The wire is about 205 feet long.

**PRACTICE**

1. Find all six trigonometric ratios for  $\theta$ .

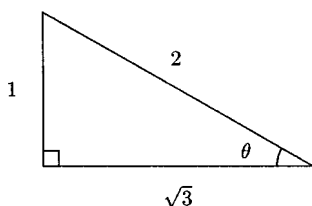

Fig. 13.41.

2. Solve the triangle.

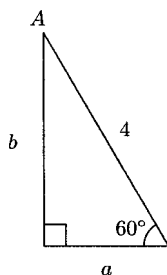

Fig. 13.42.

3. A plane is flying at an altitude of 5000 feet. The angle of elevation to the plane from a car traveling on a highway is about  $38.7^\circ$ . How far apart are the plane and car?

**SOLUTIONS**

$$\begin{aligned}
 1. \quad \sin \theta &= \frac{1}{2} & \cos \theta &= \frac{\sqrt{3}}{2} & \tan \theta &= \frac{1}{\sqrt{3}} = \frac{\sqrt{3}}{3} \\
 \csc \theta &= 2 & \sec \theta &= \frac{2}{\sqrt{3}} = \frac{2\sqrt{3}}{3} & \cot \theta &= \sqrt{3}
 \end{aligned}$$

2. We could use any of the ratios involving the hypotenuse. We will use cosine:  $\cos 60^\circ = a/4$ . Since  $\cos 60^\circ = 1/2$ , we have  $1/2 = a/4$ . Solving for  $a$  gives us  $a = 2$ .

$$2^2 + b^2 = 4^2$$

$$b = \sqrt{4^2 - 2^2} = \sqrt{12} = 2\sqrt{3}$$

$$\angle A = 90^\circ - 60^\circ = 30^\circ$$

3. We need to find  $c$  in the following triangle.

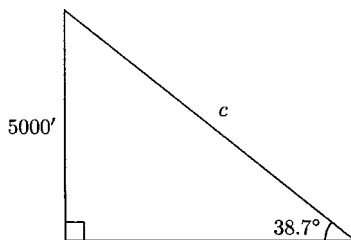

Fig. 13.43.

$$\sin 38.7^\circ = \frac{5000}{c}$$

$$c = \frac{5000}{\sin 38.7^\circ} \approx \frac{5000}{0.6252} \approx 7997$$

The plane and car are about 8000 feet apart.

## Inverse Trigonometric Functions

Only one-to-one functions can have inverses, and the trigonometric functions are certainly not one to one. But we can limit their domains and force them to be one to one. Limiting the sine function to the interval from  $x = -\pi/2$  to  $x = \pi/2$  makes  $f(x) = \sin x$  one to one. The graph in Figure 13.44 passes the Horizontal Line Test.

The domain of this function is  $[-\pi/2, \pi/2]$ , and the range is  $[-1, 1]$ . If we limit the cosine function to the interval from  $x = 0$  to  $x = \pi$ , we have another one-to-one function. Its graph is shown in Figure 13.45. The domain of this function is  $[0, \pi]$  and the range is  $[-1, 1]$ .

By limiting the tangent function from  $x = -\pi/2$  to  $x = \pi/2$ ,  $f(x) = \tan x$  is one to one. Its domain is  $(-\pi/2, \pi/2)$ , and its range is all real numbers.

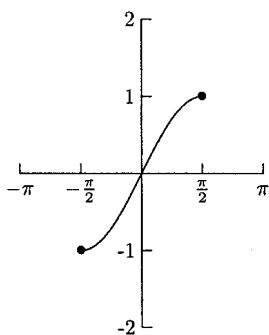

Fig. 13.44.

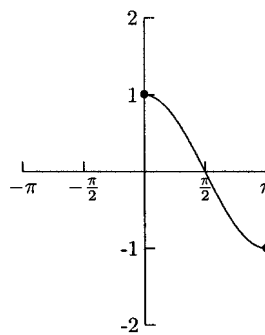

Fig. 13.45.

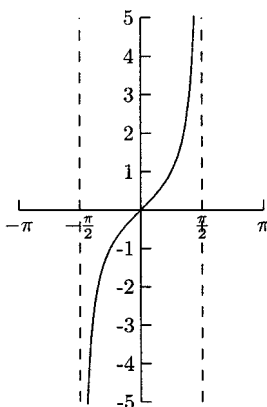

Fig. 13.46.

There are two notations for inverse trigonometric functions. One uses “ $-1$ ,” and the other uses the letters *arc*. For example, the inverse sine function is noted as  $\sin^{-1}$  or *arcsin*. Remember that for any function  $f(x)$  and its inverse  $f^{-1}(x)$ ,  $f(f^{-1}(x)) = x$  and  $f^{-1}(f(x)) = x$ . In other words, a function evaluated at its inverse “cancels” itself.

$$\cos^{-1}(\cos \pi/3) = \pi/3$$

$$\sin(\sin^{-1} 1/4) = 1/4$$

$$\tan(\tan^{-1} 1) = 1$$

$$\tan^{-1}(\tan \theta) = \theta$$

The  $x$  and  $y$  values are reversed for inverse functions. For example, if  $(4, 9)$  is a point on the graph of  $f(x)$ , then  $(9, 4)$  is a point on the graph of  $f^{-1}(x)$ . This means that the  $y$ -values for the inverse trigonometric functions are angles. Though we will need to use a calculator to evaluate most of these functions, we can find a few of them without a calculator. For  $\cos^{-1} \frac{1}{2}$ , ask yourself what angle (between 0

and  $\pi$ ) has a cosine of  $1/2$ ? Because  $\cos \pi/3 = 1/2$ ,  $\cos^{-1} \frac{1}{2} = \frac{\pi}{3}$ . When evaluating inverse trigonometric functions, we need to keep in mind what their range is. The domain of  $f(x) = \sin(x)$  is  $[-\pi/2, \pi/2]$  (Quadrants I and IV), so the range of  $y = \sin^{-1} x$  is  $[-\pi/2, \pi/2]$ . The domain of  $f(x) = \cos x$  is  $[0, \pi]$ , so the range of  $y = \cos^{-1} x$  is  $[0, \pi]$  (Quadrants I and II). And the domain of  $f(x) = \tan x$  is  $(-\pi/2, \pi/2)$ , so the range of  $y = \tan^{-1} x$  is  $(-\pi/2, \pi/2)$  (Quadrants I and IV).

## EXAMPLES

- $\sin^{-1} \sqrt{2}/2$

Because  $\sin \pi/4 = \sqrt{2}/2$ ,  $\sin^{-1} \sqrt{2}/2 = \pi/4$ .

- $\tan^{-1} \sqrt{3}$

Because  $\tan \pi/3 = \sqrt{3}$ ,  $\tan^{-1} \sqrt{3} = \pi/3$ .

- $\cos^{-1}(-1)$

$\cos^{-1}(-1) = \pi$  because  $\cos \pi = -1$ .

- $\tan^{-1}(1/3)$

None of the important angles between  $-\pi/2$  and  $\pi/2$  has a tangent of  $1/3$ , so we need to use a calculator to get an approximation:  $\tan^{-1}(1/3) \approx 0.32175$ .

- $\sin^{-1}(\cos \pi/6)$

$\cos \pi/6 = \sqrt{3}/2$ , so we need to replace  $\cos \pi/6$  with  $\sqrt{3}/2$ . This gives us  $\sin^{-1} \sqrt{3}/2$ . Because  $\sin \pi/3 = \sqrt{3}/2$ ,  $\sin^{-1} \sqrt{3}/2 = \pi/3$ .

- $\cos(\tan^{-1}(-1))$

What angle in the interval  $(-\pi/2, \pi/2)$  has a tangent of  $-1$ ? That would be  $-\pi/4$ , so  $\tan^{-1}(-1) = -\pi/4$ .

$$\cos(\tan^{-1}(-1)) = \cos\left(-\frac{\pi}{4}\right) = \frac{\sqrt{2}}{2}$$

In the next set of problems, we will use right triangles to find the exact value of expressions like  $\cos(\sin^{-1} 2/3)$ . We will begin by letting  $\sin^{-1} 2/3 = \theta$ . We can think of  $\sin^{-1} 2/3 = \theta$  as  $\sin \theta = 2/3$ . This allows us to use (Opposite/Hypotenuse) to represent  $2/3$ . We will create a right triangle with acute angle  $\theta$ , where the side opposite  $\theta$  is 2, and the hypotenuse is 3.

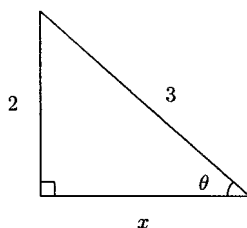

Fig. 13.47.

We want  $\cos \theta$ . We have the hypotenuse. We will use the Pythagorean Theorem to find  $x$ :  $x^2 + 2^2 = 3^2$ . This gives us  $x = \sqrt{5}$  and  $\cos \theta = \sqrt{5}/3$ . Now we have  $\cos(\sin^{-1} 2/3) = \cos \theta = \sqrt{5}/3$ .

### EXAMPLE

- $\sin(\tan^{-1} 4/5)$   
Let  $\tan^{-1} 4/5 = \theta$ , so  $\tan \theta = 4/5$ . We want a right triangle where the side opposite  $\theta$  is 4 and the side adjacent to  $\theta$  is 5.

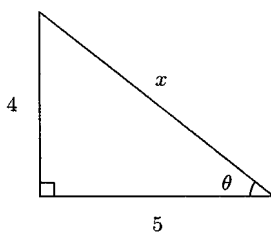

Fig. 13.48.

Solving  $4^2 + 5^2 = x^2$  gives us  $x = \sqrt{16 + 25} = \sqrt{41}$ .

$$\sin \theta = \frac{4}{\sqrt{41}} = \frac{4\sqrt{41}}{41} \text{ so, } \sin\left(\tan^{-1} \frac{4}{5}\right) = \sin \theta = \frac{4\sqrt{41}}{41}$$

We will use inverse trigonometric functions to solve right triangles when we are given one acute angle and the length of one side. We can also use them to solve right triangles when we only have the lengths of two sides.

### EXAMPLES

- Solve the triangle.



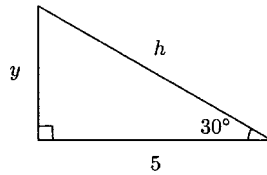

Fig. 13.49.

We need to find the side opposite  $\theta$  or the hypotenuse. If we want to find the side opposite  $\theta$ , we can use  $\tan 30^\circ = 1/\sqrt{3}$ . If we want to find the hypotenuse, we can use  $\cos 30^\circ = \sqrt{3}/2$ .

$$\cos 30^\circ = \frac{5}{h}$$

$$\frac{\sqrt{3}}{2} = \frac{5}{h}$$

$$h = 5 \cdot \frac{2}{\sqrt{3}} = \frac{10\sqrt{3}}{3}$$

$$\tan 30^\circ = \frac{y}{5}$$

$$\frac{1}{\sqrt{3}} = \frac{y}{5}$$

$$y = \frac{5}{\sqrt{3}} = \frac{5\sqrt{3}}{3}$$

The third angle is  $90^\circ - 30^\circ = 60^\circ$ .

- Solve the triangle. When rounding is necessary, give your solutions accurate to one decimal place.

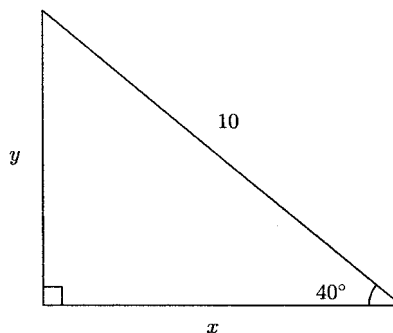

Fig. 13.50.

$$\sin 40^\circ = \frac{y}{10}$$

$$\cos 40^\circ = \frac{x}{10}$$

$$y = 10 \sin 40^\circ \approx 6.4$$

$$x = 10 \cos 40^\circ \approx 7.7$$

The third angle is  $90^\circ - 40^\circ = 50^\circ$ .

- Solve the triangle. When rounding is necessary, give your solutions accurate to one decimal place.

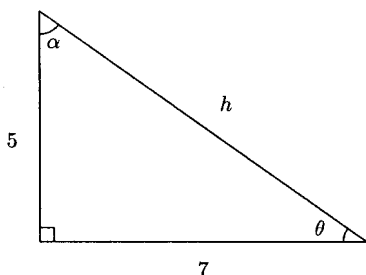

Fig. 13.51.

$$5^2 + 7^2 = h^2$$

$$h = \sqrt{25 + 49} = \sqrt{74}$$

$$\tan \theta = \frac{5}{7}$$

$$\theta = \tan^{-1} \frac{5}{7} \approx 35.5^\circ$$

$$\alpha \approx 90^\circ - 35.5^\circ \approx 54.5^\circ$$

- A 30-foot ladder is leaning against a wall. The top of the ladder is 24 feet above the ground. What angle does the ladder make with the ground?

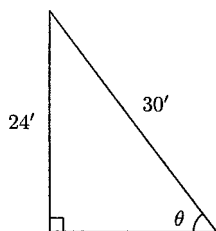

Fig. 13.52.

$$\sin \theta = \frac{24}{30}$$

$$\theta = \sin^{-1} \frac{24}{30} \approx 53.1^\circ$$

- Find  $x$ , the height of the triangle.

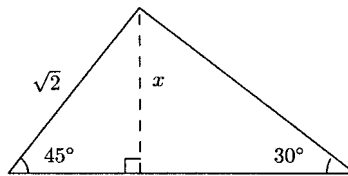

Fig. 13.53.

By viewing the triangle as two separate right triangles, the height of the triangle is the length of one of the legs of the separate triangles. We only need to use one of them.

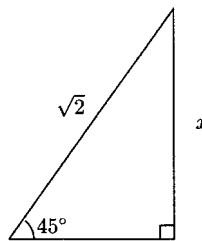

Fig. 13.54.

$$\sin 45^\circ = \frac{x}{\sqrt{2}}$$

$$x = \sqrt{2} \sin 45^\circ = \sqrt{2} \left( \frac{1}{\sqrt{2}} \right) = 1$$

We can solve other triangles using inverse trigonometric functions and the Law of Sines and/or the Law of Cosines. Although all triangles can be solved, sometimes we are given information that is true about more than one triangle or about a triangle that cannot exist. In the following problems, we will use the labels in the following triangles.

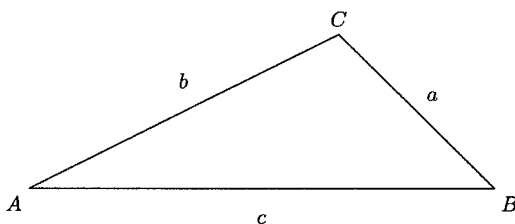

Fig. 13.55.

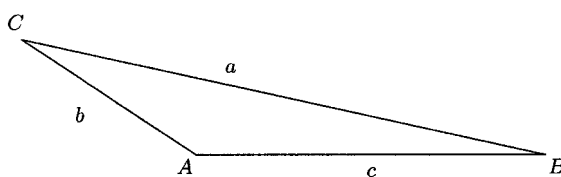

Fig. 13.56.

The angles are  $A$ ,  $B$ , and  $C$ . The sides opposite these angles are  $a$ ,  $b$ , and  $c$ , respectively.

We cannot solve a triangle if all we know are all three angles. Two triangles can be different sizes but have the same angles. Also, we might be given an angle with the side opposite the angle and another side that makes two triangles true. For example, suppose we are told to find a triangle where  $\angle A = 21^\circ$ ,  $a = 3$ , and  $b = 8$ . There are *two* triangles that satisfy these conditions.

Triangle 1	Triangle 2
$\angle A = 21^\circ$	$\angle A = 21^\circ$
$\angle B \approx 72.9^\circ$	$\angle B \approx 107.1^\circ$
$\angle C \approx 86.1^\circ$	$\angle C \approx 52^\circ$
$a = 3$	$a = 3$
$b = 8$	$b = 8$
$c \approx 8.4$	$c \approx 6.6$

There are two triangles when  $b \sin A < a < b$ . If we have another number in addition to  $A$ ,  $a$ , and  $b$ , then there will only be one triangle.

As an example of a triangle that cannot exist, let  $\angle A = 20^\circ$ ,  $b = 10$ , and  $a = 2$ . As you can see in Figure 13.57,  $a$  is too short to close the triangle. This happens when  $a < b \sin A$ .

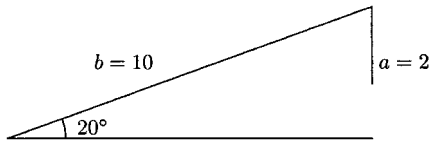

Fig. 13.57.

We can use the Law of Sines to solve a triangle if we know two sides and one of the angles opposite these sides or two angles and one side (if we know two angles, then we know all three because their sum is  $180^\circ$ ). If do not have this information, the Law of Cosines works. We can use the Law of Cosines when we have two sides and any angle or when we have all three sides.

Here is the Law of Sines.

$$\frac{\sin A}{a} = \frac{\sin B}{b} = \frac{\sin C}{c}$$

This is really three separate equations.

$$\frac{\sin A}{a} = \frac{\sin B}{b} \quad \frac{\sin B}{b} = \frac{\sin C}{c} \quad \frac{\sin A}{a} = \frac{\sin C}{c}$$

Here is the Law of Cosines.

$$a^2 = b^2 + c^2 - 2bc \cos A$$

$$b^2 = a^2 + c^2 - 2ac \cos B$$

$$c^2 = a^2 + b^2 - 2ab \cos C$$

## EXAMPLES

Solve the triangle. When rounding is necessary, give your solutions accurate to one decimal place.

- $\angle A = 30^\circ$ ,  $\angle B = 70^\circ$ , and  $a = 5$

We will use the Law of Sines because we know an angle,  $A$ , and the side opposite it,  $a$ .

$$\frac{\sin A}{a} = \frac{\sin B}{b} \text{ becomes } \frac{\sin 30^\circ}{5} = \frac{\sin 70^\circ}{b}$$

$$\frac{\sin 30^\circ}{5} = \frac{\sin 70^\circ}{b}$$

$$\frac{1/2}{5} \approx \frac{0.9397}{b} \quad (\sin 30^\circ = 1/2, \sin 70^\circ \approx 0.9397)$$

$$b \approx 10(0.9397) \approx 9.4$$

Now we will use  $(\sin A)/a = (\sin C)/c$  to find  $c$ . ( $\angle C = 180^\circ - 30^\circ - 70^\circ = 80^\circ$ )

$$\frac{\sin 30^\circ}{5} = \frac{\sin 80^\circ}{c}$$

$$\frac{1/2}{5} \approx \frac{0.9848}{c}$$

$$c \approx 10(0.9848) \approx 9.8$$

- $a = 5$ ,  $b = 8$ , and  $c = 12$

There is not enough information to get one equation with one variable using the Law of Sines, so we will use the Law of Cosines.

$$a^2 = b^2 + c^2 - 2bc \cos A$$

$$5^2 = 8^2 + 12^2 - 2(8)(12) \cos A$$

$$-183 = -192 \cos A$$

$$\frac{61}{64} = \cos A$$

$$A = \cos^{-1} \frac{61}{64}$$

$$A \approx 17.6^\circ$$

We can use either the Law of Sines or the Law of Cosines to find  $\angle B$ . The Law of Sines is a little easier.

$$\frac{\sin A}{a} = \frac{\sin B}{b}$$

$$\frac{\sin 17.6^\circ}{5} = \frac{\sin B}{8}$$

$$\sin B = \frac{8 \sin 17.6^\circ}{5} \approx 0.484$$

$$B \approx \sin^{-1} 0.484 \approx 28.9^\circ$$

$$\angle C \approx 180^\circ - 17.6^\circ - 28.9^\circ \approx 133.5^\circ$$

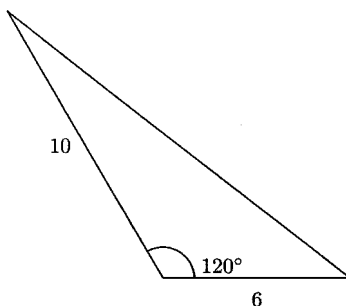

Fig. 13.58.

We will call the  $120^\circ$  angle  $A$ , then  $b = 10$  and  $c = 6$ . (It does not matter which side is  $b$  and which side is  $c$ , as long as we do not label either one of them  $a$ .) There is not enough information to use the Law of Sines, so we will use the Law of Cosines.

$$a^2 = b^2 + c^2 - 2bc \cos A$$

$$a^2 = 10^2 + 6^2 - 2(10)(6) \cos 120^\circ$$

$$a^2 = 136 - 120(-0.5)$$

$$a^2 = \sqrt{196}$$

$$a = 14$$

We can use either the Law of Sines or the Law of Cosines to find  $\angle B$  or  $\angle C$ . We will use the Law of Sines to find  $\angle B$ .

$$\frac{\sin 120^\circ}{14} = \frac{\sin B}{10}$$

$$\frac{\sqrt{3}}{2} \cdot \frac{10}{14} = \sin B \quad \left( \sin 120^\circ = \frac{\sqrt{3}}{2} \right)$$

$$B = \sin^{-1} \left( \frac{10\sqrt{3}}{28} \right) \approx \sin^{-1} 0.6186 \approx 38.2^\circ$$

$$\angle C \approx 180^\circ - 120^\circ - 38.2^\circ \approx 21.8^\circ$$

## PRACTICE

When rounding is necessary, please give your solutions accurate to one decimal place. The angles for Problems 1–6 are in radians.

- $\cos^{-1}(\cos \pi/8)$
- $\tan(\tan^{-1} -1)$
- $\cos^{-1} 1/2$
- $\sin^{-1} 1/2$
- $\tan^{-1} 0$
- $\sin^{-1} 0.9$
- Solve the triangle.

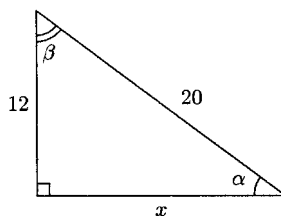

Fig. 13.59.

- A 20-foot ladder is leaning against a wall. The base of the ladder is four feet from the wall. What angle is formed by the ground and the ladder?
- Solve the triangle:  $\angle A = 42^\circ$ ,  $a = 11$ , and  $b = 6$ .
- Find all three angles for the triangle whose sides are 6, 8, and 10.
- A plane is flying over a highway at an altitude of 6000 feet. A blue car is traveling on a highway in front of the plane and a white car is on the highway behind the plane. The angle of elevation from the blue car to the plane is  $45^\circ$ . If the cars are two miles apart, how far is the plane from each car? (Hint: Consider the triangle formed by the cars and plane as two right triangles that share a leg.)

## SOLUTIONS

- $\pi/8$  radians
- $-1$  radians



3.  $\pi/3$  radians
4.  $\pi/6$  radians
5. 0 radians
6. Approximately 1.1 radians

$$7. \sin \alpha = \frac{12}{20} = \frac{3}{5}$$

$$\alpha = \sin^{-1} \frac{3}{5} \approx 36.9^\circ$$

$$\beta \approx 90^\circ - 36.9^\circ \approx 53.1^\circ$$

$$x^2 + 12^2 = 20^2$$

$$x^2 = 400 - 144$$

$$x = \sqrt{256} = 16$$

8.

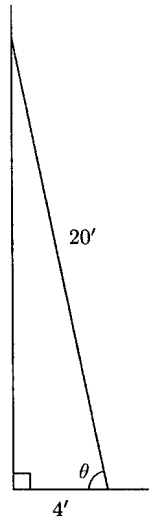

Fig. 13.60.

$$\cos \theta = \frac{4}{20} = \frac{1}{5}$$

$$\theta = \cos^{-1} \frac{1}{5} \approx 78.5^\circ$$

9. We will use the Law of Sines twice.

$$\frac{\sin 42^\circ}{11} = \frac{\sin B}{6}$$

$$\sin B = \frac{6}{11} \sin 42^\circ \approx 0.365$$

$$B \approx \sin^{-1} 0.365 \approx 21.4^\circ$$

$$C \approx 180^\circ - 21.4^\circ - 42^\circ \approx 116.6^\circ$$

$$\frac{\sin 42^\circ}{11} = \frac{\sin 116.6^\circ}{c}$$

$$c \approx \frac{11 \sin 116.6^\circ}{\sin 42^\circ} \approx 14.7$$

10. Let  $a = 6$ ,  $b = 8$ , and  $c = 10$ . We will first use the Law of Cosines to find  $\angle A$ . Then we will use the Law of Sines to find  $\angle B$ .

$$a^2 = b^2 + c^2 - 2bc \cos A$$

$$6^2 = 8^2 + 10^2 - 2(8)(10) \cos A$$

$$-128 = -160 \cos A$$

$$\frac{4}{5} = \cos A$$

$$A = \cos^{-1} \frac{4}{5} \approx 36.9^\circ$$

$$\frac{\sin 36.9^\circ}{6} = \frac{\sin B}{8}$$

$$\frac{8 \sin 36.9^\circ}{6} = \sin B$$

$$B = \sin^{-1} 0.8 \approx 53.1^\circ \quad \left( \frac{8}{6} \sin 36.9^\circ \approx 0.8 \right)$$

$$C \approx 180^\circ - 36.9^\circ - 53.1^\circ \approx 90^\circ$$

- 11.

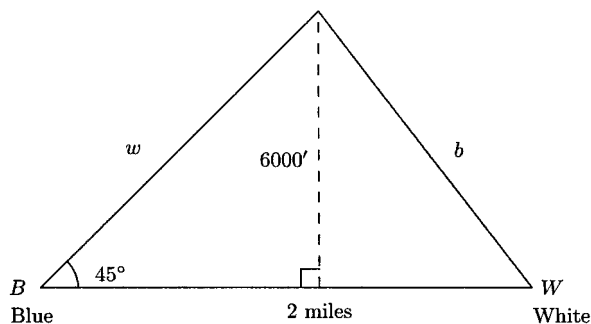

Fig. 13.61.

Let  $b$  represent the side of the original triangle that is opposite the angle  $45^\circ$ . Let  $w$  represent the side opposite  $\angle W$ , which is also the distance from the plane to the blue car. Two miles is  $2(5280) = 10,560$  feet.

$$\sin 45^\circ = \frac{6000}{w}$$

$$w = \frac{6000}{\sin 45^\circ} = \frac{6000}{1/\sqrt{2}} = \sqrt{2}(6000) \approx 8485.3$$

$$b^2 = 8485.3^2 + 10,560^2 - 2(8485.3)(10,560) \cos 45^\circ$$

$$b^2 \approx 56,793,637.9$$

$$b \approx \sqrt{56,793,637.9} \approx 7536.2$$

The plane is about 8485 feet from the blue car and about 7536 feet from the white car.

## Miscellaneous Formulas

The formulas in this section are used to find the exact value for more trigonometric ratios than the main angles— $0$ ,  $\pi/6$ ,  $\pi/4$ ,  $\pi/3$ ,  $\pi/2$ . We will find angles that are half, double, or the sum or difference of these angles. These formulas are also used to rewrite functions in a form that fits a calculus formula.

### 1. Addition and Subtraction Formulas

$$(a) \quad \sin(s + t) = \sin s \cos t + \cos s \sin t$$

$$(b) \quad \sin(s - t) = \sin s \cos t - \cos s \sin t$$

$$(c) \quad \cos(s + t) = \cos s \cos t - \sin s \sin t$$

$$(d) \quad \cos(s - t) = \cos s \cos t + \sin s \sin t$$

$$(e) \quad \tan(s + t) = \frac{\tan s + \tan t}{1 - \tan s \tan t}$$

$$(f) \quad \tan(s - t) = \frac{\tan s - \tan t}{1 + \tan s \tan t}$$

### 2. Power Reduction Formulas

$$(a) \quad \sin^2 s = \frac{1 - \cos 2s}{2}$$

$$(b) \cos^2 s = \frac{1 + \cos 2s}{2}$$

$$(c) \tan^2 s = \frac{1 - \cos 2s}{1 + \cos 2s}$$

### 3. Half-Angle and Double Angle Formulas

$$(a) \sin\left(\frac{s}{2}\right) = \pm\sqrt{\frac{1 - \cos s}{2}}$$

$$(b) \cos\left(\frac{s}{2}\right) = \pm\sqrt{\frac{1 + \cos s}{2}}$$

$$(c) \tan\left(\frac{s}{2}\right) = \frac{1 - \cos s}{\sin s} = \frac{\sin s}{1 + \cos s}$$

The sign of + or - depends on where the angle  $s/2$  lies.

$$(d) \sin 2s = 2 \sin s \cos s$$

$$(e) \cos 2s = \cos^2 s - \sin^2 s = 1 - 2 \sin^2 s = 2 \cos^2 s - 1$$

$$(f) \tan 2s = \frac{2 \tan s}{1 - \tan^2 s}$$

### 4. Product-to-Sum and Sum-to-Product Formulas

$$(a) \sin s \cos t = \frac{1}{2}[\sin(s + t) + \sin(s - t)]$$

$$(b) \cos s \sin t = \frac{1}{2}[\sin(s + t) - \sin(s - t)]$$

$$(c) \cos s \cos t = \frac{1}{2}[\cos(s + t) + \cos(s - t)]$$

$$(d) \sin s \sin t = \frac{1}{2}[\cos(s - t) - \cos(s + t)]$$

$$(e) \sin s + \sin t = 2 \sin\left(\frac{s + t}{2}\right) \cos\left(\frac{s - t}{2}\right)$$

$$(f) \sin s - \sin t = 2 \cos\left(\frac{s + t}{2}\right) \sin\left(\frac{s - t}{2}\right)$$

$$(g) \quad \cos s + \cos t = 2 \cos \left( \frac{s+t}{2} \right) \cos \left( \frac{s-t}{2} \right)$$

$$(h) \quad \cos s - \cos t = -2 \sin \left( \frac{s+t}{2} \right) \sin \left( \frac{s-t}{2} \right)$$

### EXAMPLES

- $\sin 75^\circ$

We can think of  $75^\circ$  as  $45^\circ + 30^\circ$ . This lets us use formula 1(a).

$$\sin(s+t) = \sin s \cos t + \cos s \sin t$$

$$\begin{aligned} \sin 75^\circ &= \sin(45^\circ + 30^\circ) = \sin 30^\circ \cos 45^\circ + \cos 30^\circ \sin 45^\circ \\ &= \frac{1}{2} \cdot \frac{\sqrt{2}}{2} + \frac{\sqrt{3}}{2} \cdot \frac{\sqrt{2}}{2} = \frac{\sqrt{2}}{4} + \frac{\sqrt{6}}{4} \\ &= \frac{\sqrt{2} + \sqrt{6}}{4} \end{aligned}$$

- $\cos 15^\circ$

We will use formula 3(b) because  $15^\circ = \frac{30^\circ}{2}$ .

$$\cos \frac{s}{2} = \sqrt{\frac{1 + \cos s}{2}}$$

$$\begin{aligned} \cos 15^\circ &= \cos \left( \frac{30^\circ}{2} \right) = \sqrt{\frac{1 + \cos 30^\circ}{2}} \\ &= \sqrt{\frac{1 + \sqrt{3}/2}{2}} = \sqrt{\frac{\frac{2}{2} + \frac{\sqrt{3}}{2}}{2}} = \sqrt{\frac{2 + \sqrt{3}}{2}} \\ &= \sqrt{\frac{2 + \sqrt{3}}{4}} = \frac{\sqrt{2 + \sqrt{3}}}{\sqrt{4}} = \frac{\sqrt{2 + \sqrt{3}}}{2} \end{aligned}$$

- $\tan 7\pi/12$

Because  $\frac{7\pi}{12} = \frac{\pi}{4} + \frac{\pi}{3}$ , we can use formula 1(e).

$$\begin{aligned}\tan(s+t) &= \frac{\tan s + \tan t}{1 - \tan s \tan t} \\ \tan \frac{7\pi}{12} &= \tan \left( \frac{\pi}{4} + \frac{\pi}{3} \right) = \frac{\tan \pi/4 + \tan \pi/3}{1 - \tan \pi/4 \tan \pi/3} = \frac{1 + \sqrt{3}}{1 - 1(\sqrt{3})} \\ &= \frac{1 + \sqrt{3}}{1 - \sqrt{3}} = \frac{(1 + \sqrt{3})(1 + \sqrt{3})}{(1 - \sqrt{3})(1 + \sqrt{3})} \\ &= \frac{1 + 2\sqrt{3} + (\sqrt{3})^2}{1 - (\sqrt{3})^2} \\ &= \frac{1 + 2\sqrt{3} + 3}{1 - 3} = \frac{4 + 2\sqrt{3}}{-2} = -\frac{2(2 + \sqrt{3})}{2} \\ &= -(2 + \sqrt{3})\end{aligned}$$

- If  $\cos \theta = 3/5$  and  $\theta$  is in Quadrant I, find  $\sin 2\theta$ .

By formula 3(d),  $\sin 2\theta = 2 \sin \theta \cos \theta$ . We need to find  $\sin \theta$  so that we can use the formula.

$$\sin^2 \theta + \cos^2 \theta = 1$$

$$\sin^2 \theta + \left(\frac{3}{5}\right)^2 = 1$$

$$\sin \theta = \sqrt{1 - \left(\frac{3}{5}\right)^2} = \frac{4}{5}$$

$$\sin 2\theta = 2 \sin \theta \cos \theta = 2 \left(\frac{4}{5}\right) \left(\frac{3}{5}\right) = \frac{24}{25}$$

- $\cos^2 \pi/12 - \sin^2 \pi/12$

The expression looks like formula 3(e), where  $s = \pi/12$ .

$$\begin{aligned}\cos^2 s - \sin^2 s &= \cos 2s \\ \cos^2 \frac{\pi}{12} - \sin^2 \frac{\pi}{12} &= \cos \left( 2 \cdot \frac{\pi}{12} \right) \\ &= \cos \frac{\pi}{6} = \frac{\sqrt{3}}{2}\end{aligned}$$

- Suppose  $\cos 2\theta = 1/4$ . Find  $\sin^2 \theta$ .

We will use formula 2(a).

$$\sin^2 \theta = \frac{1 - \cos 2\theta}{2} = \frac{1 - \frac{1}{4}}{2} = \frac{\frac{4}{4} - \frac{1}{4}}{2} = \frac{\frac{3}{4}}{2} = \frac{3}{4 \cdot 2} = \frac{3}{8}$$

- Write  $\cos^4 x$  without squaring any trigonometric functions.

We will use formula 2(b) twice.

$$\begin{aligned}\cos^4 x &= (\cos^2 x)(\cos^2 x) \\ &= \left( \frac{1 + \cos 2x}{2} \right) \left( \frac{1 + \cos 2x}{2} \right) \\ &= \frac{1}{2}(1 + \cos 2x) \cdot \frac{1}{2}(1 + \cos 2x) \\ &= \frac{1}{4}(1 + \cos 2x)(1 + \cos 2x) \\ &= \frac{1}{4}(1 + 2 \cos 2x + \cos^2 2x) && \text{Use the formula for } s = 2x. \\ &= \frac{1}{4} \left[ 1 + 2 \cos 2x + \left( \frac{1 + \cos 2 \cdot 2x}{2} \right) \right] \\ &= \frac{1}{4} \left[ 1 + 2 \cos 2x + \frac{1}{2} (1 + \cos 4x) \right]\end{aligned}$$

- Rewrite  $\cos 2x \cos 5x$  as a sum or difference.

Formula 4(c) tells us how to write the product of two cosines as a sum.

$$\begin{aligned}\cos 2x \cos 5x &= \frac{1}{2} [\cos(2x + 5x) + \cos(2x - 5x)] \\ &= \frac{1}{2} [\cos(7x) + \cos(-3x)] \\ &= \frac{1}{2} (\cos 7x + \cos 3x) \qquad \text{(Because cosine is even,} \\ &\qquad \qquad \qquad \cos 3x = \cos(-3x).)\end{aligned}$$

- Rewrite  $\sin 3x - \sin 2x$  as a product.

This fits formula 4(f).

$$\sin 3x - \sin 2x = 2 \cos \frac{3x + 2x}{2} \sin \frac{3x - 2x}{2} = 2 \cos \frac{5x}{2} \sin \frac{x}{2}$$

## PRACTICE

1. Find  $\tan 15^\circ$  using the half-angle formula.
2. If  $\sin \theta = 2/3$  and  $\theta$  is in Quadrant II, find  $\sin 2\theta$ .
3. Write  $\sin^4 x$  using only the first powers of trigonometric functions.
4. Write  $\cos 4x \sin 6x$  as a sum.

## SOLUTIONS

1. Use formula 3(c).

$$\begin{aligned}\tan 15^\circ &= \tan \left( \frac{30^\circ}{2} \right) = \frac{1 - \cos 30^\circ}{\sin 30^\circ} = \frac{1 - \sqrt{3}/2}{1/2} = \left( 1 - \frac{\sqrt{3}}{2} \right) \div \frac{1}{2} \\ &= \left( 1 - \frac{\sqrt{3}}{2} \right) \cdot 2 = 2 - \sqrt{3}\end{aligned}$$

2. Because  $\theta$  is in Quadrant II, cosine will be negative.

$$\sin^2 \theta + \cos^2 \theta = 1$$

$$\left( \frac{2}{3} \right)^2 + \cos^2 \theta = 1$$



$$\cos \theta = -\sqrt{1 - \left(\frac{2}{3}\right)^2} = -\sqrt{\frac{5}{9}} = -\frac{\sqrt{5}}{3}$$

$$\sin 2\theta = 2 \sin \theta \cos \theta \quad \text{Formula 3(d)}$$

$$= 2 \left(\frac{2}{3}\right) \left(\frac{-\sqrt{5}}{3}\right) = -\frac{4\sqrt{5}}{9}$$

$$3. \sin^4 x = (\sin^2 x)(\sin^2 x)$$

$$(\sin^2 x)(\sin^2 x) = \frac{1 - \cos 2x}{2} \cdot \frac{1 - \cos 2x}{2} \quad \text{Formula 2(a)}$$

$$= \frac{1}{2}(1 - \cos 2x) \cdot \frac{1}{2}(1 - \cos 2x)$$

$$= \frac{1}{4}(1 - \cos 2x)(1 - \cos 2x)$$

$$= \frac{1}{4}(1 - 2 \cos 2x + \cos^2 2x)$$

$$= \frac{1}{4} \left[ 1 - 2 \cos 2x + \left( \frac{1 + \cos 2 \cdot 2x}{2} \right) \right] \quad \text{Formula 2(b)}$$

$$= \frac{1}{4} \left[ 1 - 2 \cos 2x + \frac{1}{2}(1 + \cos 4x) \right]$$

4. We will use formula 4(b).

$$\cos 4x \sin 6x = \frac{1}{2}[\sin(4x + 6x) - \sin(4x - 6x)]$$

$$= \frac{1}{2}[\sin(10x) - \sin(-2x)]$$

$$= \frac{1}{2}[\sin 10x + \sin 2x]$$

Because sine is odd,  
 $\sin(-2x) = -\sin 2x$ .

## CHAPTER 13 REVIEW

1. Find  $\sin \theta$  if  $\cos \theta = -\frac{1}{4}$  and  $\theta$  is in Quadrant II.

(a)  $\frac{\sqrt{15}}{4}$

(b)  $-\frac{\sqrt{15}}{4}$

(c)  $\frac{\sqrt{3}}{2}$

(d)  $-\frac{\sqrt{3}}{2}$

2. What is the phase shift for  $f(x) = 2 \cos(3x + \pi/2)$ ?  
 (a)  $-\frac{\pi}{2}$                       (b)  $\frac{\pi}{2}$                       (c)  $-\frac{\pi}{6}$                       (d)  $\frac{\pi}{6}$
3. What is the period for  $f(x) = 2 \cos(3x + \pi/2)$ ?  
 (a)  $\frac{2\pi}{3}$                       (b)  $6\pi$                       (c)  $\frac{2}{3}$                       (d)  $\frac{\pi}{3}$
4. From the top of a 200-foot lighthouse, the angle of depression to a ship on the ocean is  $20^\circ$ . How far is the ship from the base of the lighthouse?  
 (a) About 400 feet                      (b) About 490 feet  
 (c) About 550 feet                      (d) About 690 feet
5.  $\cos 15^\circ \cos 10^\circ + \sin 15^\circ \sin 10^\circ =$   
 (a)  $\cos 5^\circ$                       (b)  $\cos 25^\circ$                       (c)  $\sin 5^\circ$                       (d)  $\sin 25^\circ$
6. Find the reference angle for  $7\pi/9$ .  
 (a)  $\frac{2\pi}{9}$                       (b)  $-\frac{2\pi}{9}$                       (c)  $\frac{16\pi}{9}$                       (d)  $\frac{7\pi}{9}$
7. The terminal point for  $\theta$  is  $(-3/5, 4/5)$ . What is  $\tan \theta$ ?  
 (a)  $-\frac{4}{3}$                       (b)  $-\frac{3}{4}$                       (c)  $-\frac{5}{3}$                       (d)  $\frac{5}{4}$
8.  $\tan(\cos^{-1} 3/4) =$   
 (a)  $\frac{3\sqrt{7}}{7}$                       (b)  $\frac{\sqrt{7}}{3}$                       (c)  $\frac{4\sqrt{7}}{7}$                       (d)  $\frac{\sqrt{7}}{4}$
9. The graph in Figure 13.62 is the graph of one period of which function?  
 (a)  $y = 2 \cos(x + \pi/3)$                       (b)  $y = 2 \cos(x - \pi/3)$   
 (c)  $y = \cos 2(x + \pi/3)$                       (d)  $y = \cos 2(x - \pi/3)$

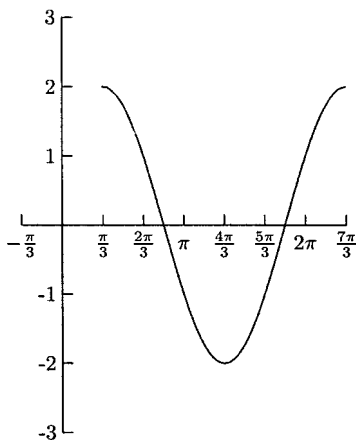

Fig. 13.62.

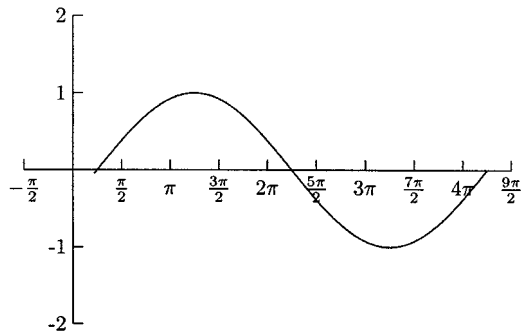

Fig. 13.63.

10. The graph in Figure 13.63 is the graph of one period of which function?
- (a)  $y = \sin \frac{1}{2}(x - \pi/4)$                       (b)  $y = \frac{1}{2} \sin(x + \pi/4)$   
 (c)  $y = \sin \frac{1}{2}(x + \pi/4)$                       (d)  $y = \frac{1}{2} \sin(x + \pi/4)$

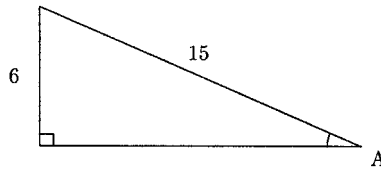

Fig. 13.64.

11. Find  $\angle A$ .
- (a) About  $68.2^\circ$                                       (b) About  $21.8^\circ$   
 (c) About  $66.4^\circ$                                       (d) About  $23.6^\circ$

## SOLUTIONS

1. A      2. C      3. A      4. B      5. A      6. A  
 7. A      8. B      9. C      10. A      11. D

# Sequences and Series

A *sequence* is an ordered list of numbers. Although they list the same numbers, the sequence 1, 2, 3, 4, 5, 6, ... is different from the sequence 2, 1, 4, 3, 6, 5, ... Usually a sequence is infinite. This means that there is no last term in the sequence. A *series* is the sum (if it exists) of a sequence. Although a sequence can be any list of numbers, we will work with sequences that can be found from a formula. Formulas describe how to compute the  $n$ th term,  $a_n$ . For example, the formula  $a_n = 2n + 1$  gives us this sequence.

$$\begin{array}{ccccccc} 3, & 5, & 7, & 9, & \dots & & \\ 2(1)+1 & 2(2)+1 & 2(3)+1 & 2(4)+1 & & & \end{array}$$

## EXAMPLES

Find the first four terms and the 50th term of the sequence.

- $a_n = n^2 - 10$

The first term is  $a_1 = 1^2 - 10 = -9$ ; the second term is  $a_2 = 2^2 - 10 = -6$ ; the third term is  $a_3 = 3^2 - 10 = -1$ ; the fourth term is  $a_4 = 4^2 - 10 = 6$ ; and the 50th term is  $a_{50} = 50^2 - 10 = 2490$ .

- $a_n = \frac{n-1}{n+1}$

$$a_1 = \frac{1-1}{1+2} = 0 \quad a_2 = \frac{2-1}{2+1} = \frac{1}{3} \quad a_3 = \frac{3-1}{3+1} = \frac{1}{2}$$

$$a_4 = \frac{4-1}{4+1} = \frac{3}{5} \quad a_{50} = \frac{50-1}{50+1} = \frac{49}{51}$$

- $a_n = (-1)^n$

$$a_1 = (-1)^1 = -1 \quad a_2 = (-1)^2 = 1 \quad a_3 = (-1)^3 = -1$$

$$a_4 = (-1)^4 = 1 \quad a_{50} = (-1)^{50} = 1$$

Finding the terms of a sequence is the same function evaluation we did earlier. Sequences are special kinds of functions whose domain is the natural numbers (instead of intervals of real numbers).

We can write the formulas for many sequences using the previous term. For example, the next term of the sequence 3, 5, 7, 9, ... can be found by adding 2 to the previous term. In other words, we could use the formula  $a_n = a_{n-1} + 2$ . This is a *recursive* formula. This formula is not of much use unless we know how to start. For this reason, the value of  $a_1$  is usually given with recursively defined sequences. A complete recursive definition for this sequence is  $a_n = a_{n-1} + 2$ ,  $a_1 = 3$ . Now we can compute the terms of the sequence.

$$\begin{array}{ccccccc} 3, & 5, & 7, & 9, & \dots & & \\ & 3+2 & 5+2 & 7+2 & & & \end{array}$$

## EXAMPLES

Find the first four terms of the sequence.

- $a_n = 3a_{n-1} + 5$ ,  $a_1 = -4$

Think of  $3a_{n-1} + 5$  as “3 times the previous term plus 5.”

$$a_1 = -4 \quad a_2 = 3(-4) + 5 = -7$$

$$a_3 = 3(-7) + 5 = -16 \quad a_4 = 3(-16) + 5 = -43$$

- $a_n = \frac{a_{n-1}}{a_{n-2}}, a_1 = 2, a_2 = 4$

The terms of this sequence are found by taking the quotient of the previous two terms.

$$a_1 = 2 \quad a_2 = 4 \quad a_3 = \frac{a_{3-1}}{a_{3-2}} = \frac{a_2}{a_1} = \frac{4}{2} = 2 \quad a_4 = \frac{a_3}{a_2} = \frac{2}{4} = \frac{1}{2}$$

A famous recursively defined sequence is the Fibonacci Sequence. Entire books are written about it! The  $n$ th term of the Fibonacci Sequence is  $a_n = a_{n-1} + a_{n-2}$  and  $a_1 = 1$  and  $a_2 = 1$ . From the third term on, each term is the sum of the previous two terms. The first few terms are 1, 1, 2, 3, 5, 8, 13, ...

Instead of using a formula to describe a sequence, we might be given the first few terms. From these terms we should be able to see enough of a pattern to write a formula for the  $n$ th term.

## EXAMPLES

Find the next term in the sequence.

- 2, 6, 18, 54, ...

The next term is  $3(54) = 162$ .

- $1, \frac{1}{2}, \frac{1}{3}, \frac{1}{4}, \dots$

The next term is  $\frac{1}{5}$

- 1, -2, 4, -8, 16, ...

The next term is  $-2(16) = -32$ .

Find a formula for the  $n$ th term for the next four examples. Do not use a recursive definition.

- 3, 9, 27, 81, ...

$$3 = 3^1, 9 = 3^2, 27 = 3^3, 81 = 3^4$$

The  $n$ th term is  $a_n = 3^n$ .

- -2, -4, -6, -8, -10, ...

$$-2 = -2(1), -4 = -2(2), -6 = -2(3), -8 = -2(4), -10 = -2(5)$$

The  $n$ th term is  $a_n = -2n$ .

- -1, 4, -9, 16, -25, ...

$$-1 = -1^2, 4 = 2^2, -9 = -3^2, 16 = 4^2, -25 = -5^2$$

If we want the signs to alternate, we can use the factor  $(-1)^n$  (if we want the odd-numbered terms to be negative) or  $(-1)^{n+1}$  (if we want the even-numbered terms to be negative). The  $n$ th term of this sequence is  $a_n = (-1)^n n^2$ .

- $\frac{1}{2}, \frac{2}{3}, \frac{3}{4}, \frac{4}{5}, \dots$

$$\frac{1}{2} = \frac{1}{1+1}, \quad \frac{2}{3} = \frac{2}{2+1}, \quad \frac{3}{4} = \frac{3}{3+1}, \quad \frac{4}{5} = \frac{4}{4+1}$$

The  $n$ th term is  $a_n = \frac{n}{n+1}$ .

There are times when we want to add the first  $n$  terms of a sequence. The sum

$$a_1 + a_2 + a_3 + \dots + a_n$$

is called the  $n$ th partial sum of the sequence. Its notation is  $S_n$ .

$$S_1 = a_1$$

$$S_2 = a_1 + a_2$$

$$S_3 = a_1 + a_2 + a_3$$

$$S_4 = a_1 + a_2 + a_3 + a_4$$

Another common notation for the  $n$ th partial sum uses the capital Greek letter sigma, “ $\Sigma$ .” This notation also makes use of  $a_n$  or a formula for  $a_n$ . “ $\sum_{n=1}^5 a_n$ ” means “add the  $a_n$ s beginning with  $a_1$  and ending with  $a_5$ .”

$$\sum_{n=1}^5 a_n = a_1 + a_2 + a_3 + a_4 + a_5$$

The subscript  $n$  is called the *index of summation*. Other common indices are  $i$ ,  $j$ , and  $k$ .

## EXAMPLES

Write the sum.

- $\sum_{n=1}^6 \frac{n^2}{4}$

$$\frac{1}{4} + 1 + \frac{9}{4} + 4 + \frac{25}{4} + 9$$

$$\frac{1^2}{4} + \frac{2^2}{4} + \frac{3^2}{4} + \frac{4^2}{4} + \frac{5^2}{4} + \frac{6^2}{4}$$

- $\sum_{n=1}^5 (-1)^{n+1} (3n - 4)$

$$(-1)^{1+1}(3 \cdot 1 - 4) - \frac{2}{(-1)^{2+1}(3 \cdot 2 - 4)} + \frac{5}{(-1)^{3+1}(3 \cdot 3 - 4)} - \frac{8}{(-1)^{4+1}(3 \cdot 4 - 4)} + \frac{11}{(-1)^{5+1}(3 \cdot 5 - 4)}$$

Write the sum using summation notation.

- $1 + \frac{1}{2} + \frac{1}{3} + \frac{1}{4} + \cdots + \frac{1}{20}$

This is the sum of the first 20 terms in a sequence, so we will begin by writing “ $\sum_{n=1}^{20}$ .” The  $n$ th term of the sequence is  $a_n = \frac{1}{n}$ , and the summation notation for this sum is

$$\sum_{n=1}^{20} \frac{1}{n}.$$

- $2 + 4 + 6 + 8 + 10 + 12$

This is the sum of the first six terms of the sequence whose  $n$ th term is  $a_n = 2n$ . The summation notation is  $\sum_{n=1}^6 2n$ .

- $\frac{1}{2} - \frac{1}{4} + \frac{1}{6} - \frac{1}{8} + \frac{1}{10} - \cdots + \frac{1}{18}$

This is the sum of the first nine terms of the sequence whose  $n$ th term is  $a_n = (-1)^{n+1} \frac{1}{2n}$ . The summation notation is

$$\sum_{n=1}^9 (-1)^{n+1} \frac{1}{2n}.$$

There are formulas for finding the  $n$ th partial sum for special sequences. Using these formulas, we can add many terms of a sequence with little work. We will learn the formulas for the sums of two important sequences, *arithmetic sequences* and *geometric sequences*, later.

## PRACTICE

1. Find the first four terms and the 100th term of the sequence whose  $n$ th term is  $a_n = \frac{2n-1}{n+1}$ .
2. Find the first four terms and the 100th term of the sequence whose  $n$ th term is  $a_n = (-1)^{n+1} \frac{n^2}{2}$ .



3. Find the first four terms of the sequence whose  $n$ th term is  $a_n = \sqrt{a_{n-1}}$  and  $a_1 = 256$ .
4. Without using a recursive definition, find the  $n$ th term for the sequence

$$10, 5, \frac{5}{2}, \frac{5}{4}, \frac{5}{8}, \frac{5}{16}, \dots$$

5. Without using a recursive definition, find the  $n$ th term for the sequence

$$\frac{0}{3}, \frac{1}{4}, \frac{2}{5}, \frac{3}{6}, \frac{4}{7}, \dots$$

6. Write the sum for  $\sum_{n=1}^6 \frac{5}{2^n}$ .
7. Write the sum using summation notation.

$$\frac{1}{3} - \frac{1}{9} + \frac{1}{27} - \frac{1}{81} + \frac{1}{243}$$

## SOLUTIONS

$$1. \quad a_1 = \frac{2(1) - 1}{1 + 1} = \frac{1}{2} \quad a_2 = \frac{2(2) - 1}{2 + 1} = 1 \quad a_3 = \frac{2(3) - 1}{3 + 1} = \frac{5}{4}$$

$$a_4 = \frac{2(4) - 1}{4 + 1} = \frac{7}{5} \quad a_{100} = \frac{2(100) - 1}{100 + 1} = \frac{199}{101}$$

$$2. \quad a_1 = (-1)^{1+1} \frac{1^2}{2} = \frac{1}{2} \quad a_2 = (-1)^{2+1} \frac{2^2}{2} = -2$$

$$a_3 = (-1)^{3+1} \frac{3^2}{2} = \frac{9}{2} \quad a_4 = (-1)^{4+1} \frac{4^2}{2} = -8$$

$$a_{100} = (-1)^{100+1} \frac{100^2}{2} = -5000$$

$$3. \quad a_1 = 256 \quad a_2 = \sqrt{256} = 16$$

$$a_3 = \sqrt{16} = 4 \quad a_4 = \sqrt{4} = 2$$

$$4. \quad a_n = 20\left(\frac{1}{2}\right)^n \text{ or } a_n = 10\left(\frac{1}{2}\right)^{n-1}$$

$$5. \quad a_n = \frac{n-1}{n+2}$$

$$6. \frac{5}{2} + \frac{5}{4} + \frac{5}{6} + \frac{5}{8} + \frac{5}{10} + \frac{5}{12}$$

$$7. \sum_{n=1}^5 (-1)^{n+1} \left(\frac{1}{3}\right)^n \quad \text{or} \quad \sum_{n=1}^5 (-1)^{n+1} \frac{1}{3^n}$$

## Arithmetic Sequences

A term in an arithmetic sequence is computed by adding a fixed number to the previous term. For example, 3, 7, 11, 15, 19, ... is an arithmetic sequence because we can add 4 to any term to find the following term. We can define the  $n$ th term recursively as  $a_n = a_{n-1} + d$  or, in more general terms,  $a_n = a_1 + (n - 1)d$ . In the sequence above,  $a_1 = 3$  and  $d = 4$ .

### EXAMPLES

Find the first four terms and the 100th term.

- $a_n = 28 + (n - 1)1.5$

$$a_1 = 28$$

$$a_2 = 28 + (2 - 1)1.5 = 29.5$$

$$a_3 = 28 + (3 - 1)1.5 = 31$$

$$a_4 = 28 + (4 - 1)1.5 = 32.5$$

$$a_{100} = 28 + (100 - 1)1.5 = 176.5$$

- $a_n = -2 + (n - 1)(-6)$

$$a_1 = -2$$

$$a_2 = -2 + (2 - 1)(-6) = -8$$

$$a_3 = -2 + (3 - 1)(-6) = -14$$

$$a_4 = -2 + (4 - 1)(-6) = -20$$

$$a_{100} = -2 + (100 - 1)(-6) = -596$$

When asked whether or not a sequence is arithmetic, we will find the difference between consecutive terms. If the difference is the same, the sequence is arithmetic.

### EXAMPLES

Determine if the sequence is arithmetic. If it is, find the common difference.

- $-8, -1, 6, 13, 20, \dots$

$$20 - 13 = 7, \quad 13 - 6 = 7, \quad 6 - (-1) = 7, \quad -1 - (-8) = 7$$

The sequence is arithmetic. The common difference is 7.

- 29, 17, 5, -7, -19, ...

$$-19 - (-7) = -12, \quad -7 - 5 = -12, \quad 5 - 17 = -12, \quad 17 - 29 = -12$$

The sequence is arithmetic, and the common difference is -12.

- $\frac{5}{3}, \frac{5}{6}, \frac{5}{12}, \frac{5}{24}, \dots$

$$\frac{5}{24} - \frac{5}{12} = -\frac{5}{24}, \quad \frac{5}{12} - \frac{5}{6} = -\frac{5}{12}$$

Because the differences are not the same, the sequence is not arithmetic.

We can find any term in an arithmetic sequence if we know either one term and the common difference or two terms. We need to use the formula  $a_n = a_1 + (n - 1)d$  and, if necessary, a little algebra. For example, if we are told the common difference is 6 and the tenth term is 141, then we can put  $a_n = 141$ ,  $n = 10$ , and  $d = 6$  in the formula to find  $a_1$ .

$$141 = a_1 + (10 - 1)6$$

$$87 = a_1$$

The  $n$ th term is  $a_n = 87 + (n - 1)6$ .

## EXAMPLES

Find the  $n$ th term for the arithmetic sequence.

- The common difference is  $\frac{2}{3}$  and the seventh term is -10.  
Using  $d = \frac{2}{3}$ ,  $n = 7$ , and  $a_n = -10$ , the formula  $a_n = a_1 + (n - 1)d$  becomes  $-10 = a_1 + (7 - 1)\frac{2}{3}$ .

$$-10 = a_1 + (7 - 1)\frac{2}{3}$$

$$-10 = a_1 + 4$$

$$-14 = a_1$$

The  $n$ th term is  $a_n = -14 + (n - 1)\frac{2}{3}$ .

- The twelfth term is 8, and the twentieth term is 32.  
The information gives us a system of two equations with two variables. In this example and the rest of the problems in this section, we will add -1

times the first equation to the second. Substitution and matrices would work, too. The equations are  $8 = a_1 + (12 - 1)d$  and  $32 = a_1 + (20 - 1)d$ .

$$-a_1 - 11d = -8$$

$$\underline{a_1 + 19d = 32}$$

$$8d = 24$$

$$d = 3$$

$$a_1 + 11(3) = 8 \quad \text{Let } d = 3 \text{ in } a_1 + 11d = 8$$

$$a_1 = -25$$

The  $n$ th term is  $a_n = -25 + (n - 1)3$ .

- The eighth term is 4, and the twentieth term is  $-38$ .  
The information in these two terms gives us the system of equations  $4 = a_1 + (8 - 1)d$  and  $-38 = a_1 + (20 - 1)d$ .

$$-a_1 - 7d = -4$$

$$\underline{a_1 + 19d = -38}$$

$$12d = -42$$

$$d = -\frac{7}{2}$$

$$a_1 + 7\left(-\frac{7}{2}\right) = 4 \quad \text{Let } d = -\frac{7}{2} \text{ in } a_1 + 7d = 4$$

$$a_1 = \frac{57}{2}$$

The  $n$ th term is  $a_n = \frac{57}{2} + (n - 1)\left(-\frac{7}{2}\right)$ .

We can add the first  $n$  terms of an arithmetic sequence using one of the following two formulas.

$$S_n = \frac{n}{2}(a_1 + a_n) \quad \text{or} \quad S_n = \frac{n}{2}[2a_1 + (n - 1)d]$$

We will use the first formula if we know all of  $a_1$ ,  $a_n$ , and  $n$ , and the second if we do not know  $a_n$ .

## EXAMPLES

- Find the sum.

$$2 + \frac{13}{5} + \frac{16}{5} + \frac{19}{5} + \frac{22}{5} + 5$$

$a_1 = 2$ ,  $a_6 = 5$ , and  $n = 6$  (because there are six terms)

$$2 + \frac{13}{5} + \frac{16}{5} + \frac{19}{5} + \frac{22}{5} + 5 = \frac{6}{2}(2 + 5) = 21$$

- Find the sum of the first 20 terms of the sequence  $-5, -1, 3, 7, 11, \dots$   
 $a_1 = -5$ ,  $d = 4$ , and  $n = 20$ .

$$S_{20} = \frac{20}{2}[2(-5) + (20 - 1)4] = 660$$

- $6 + (-2) + (-10) + (-18) + \dots + (-58)$   
We know  $a_1 = 6$ ,  $d = -8$  and  $a_n = -58$  but not  $n$ . We can find  $n$  by solving  $-58 = 6 + (n - 1)(-8)$ .

$$-58 = 6 + (n - 1)(-8)$$

$$-64 = -8(n - 1)$$

$$8 = n - 1$$

$$9 = n$$

$$6 + (-2) + (-10) + (-18) + \dots + (-58) = \frac{9}{2}[6 + (-58)] = -234$$

- Find the sum of the first thirty terms of the arithmetic sequence whose fifth term is 19 and whose tenth term is 31.5.  
In order to use the second sum formula, we need to find  $a_1$  and  $d$ . If we were to use the first formula, we would have to find  $a_{30}$ , which is a little more work. Because  $a_5 = 19$  and  $a_{10} = 31.5$ , we have the system of equations  $19 = a_1 + (5 - 1)d$  and  $31.5 = a_1 + (10 - 1)d$ .

$$-a_1 - 4d = -19$$

$$\underline{a_1 + 9d = 31.5}$$

$$5d = 12.5$$

$$d = 2.5$$

$$a_1 + 4(2.5) = 19 \quad \text{Let } d = 2.5 \text{ in } a_1 + 4d = 19$$

$$a_1 = 9$$

$$S_{30} = \frac{30}{2}[2(9) + (30 - 1)(2.5)] = 1357.5$$

## PRACTICE

1. Find the first four terms and the 40th term of the arithmetic sequence whose  $n$ th term is  $a_n = 14 + (n - 1)4$ .
2. Determine if the sequence 0.03, 0.33, 0.63, 0.93, ... is arithmetic.
3. Determine if the sequence 0.4, 0.04, 0.004, 0.0004, ... is arithmetic.
4. Find the  $n$ th term of the arithmetic sequence whose first term is 16 and whose ninth term is 54.
5. Find the  $n$ th term of the arithmetic sequence whose sixth term is 12 and whose tenth term is 36.
6. Compute the sum.

$$-8 + \left(-\frac{35}{4}\right) + \left(-\frac{38}{4}\right) + \left(-\frac{41}{4}\right) + (-11) + \left(-\frac{47}{4}\right)$$

7. Compute the sum.  $10 + 17 + 24 + 31 + \dots + 108$
8. Find the sum of the first twelve terms of the arithmetic sequence whose fourth term is 8 and whose tenth term is 56.

## SOLUTIONS

1.  $a_1 = 14$ ,  $a_2 = 14 + (2 - 1)4 = 18$ ,  $a_3 = 14 + (3 - 1)4 = 22$ ,  $a_4 = 14 + (4 - 1)4 = 26$  and  $a_{40} = 14 + (40 - 1)4 = 170$ .
2.  $0.93 - 0.63 = 0.3$ ,  $0.63 - 0.33 = 0.3$ ,  $0.33 - 0.03 = 0.3$   
The differences are the same, so the sequence is arithmetic.
3.  $0.0004 - 0.004 = -0.0036$ ,  $0.004 - 0.04 = -0.036$   
The differences are not the same, so the sequence is not arithmetic.
4. Because  $a_1 = 16$ , we have  $a_n = 16 + (n - 1)d$ . Using  $a_9 = 54$  in this formula, we have  $54 = 16 + (9 - 1)d$ . Solving this equation for  $d$  gives us  $d = \frac{19}{4}$ . The  $n$ th term is  $a_n = 16 + (n - 1)\frac{19}{4}$ .

5. From the information in the problem, we have the system  $12 = a_1 + (6-1)d$  and  $36 = a_1 + (10-1)d$ .

$$-a_1 - 5d = -12$$

$$\underline{a_1 + 9d = 36}$$

$$4d = 24$$

$$d = 6$$

$$a_1 + 5(6) = 12 \quad \text{Let } d = 6 \text{ in } a_1 + 5d = 12$$

$$a_1 = -18$$

The  $n$ th term is  $a_n = -18 + (n-1)6$ .

6.  $a_1 = -8$ ,  $a_6 = -\frac{47}{4}$ , and  $n = 6$ .  $S_n = \frac{n}{2}(a_1 + a_n)$  becomes  $S_6 = \frac{6}{2}(-8 + (-\frac{47}{4})) = -\frac{237}{4}$ .
7.  $a_1 = 10$ ,  $d = 7$ , and  $a_n = 108$ . We can find  $n$  by solving  $108 = 10 + (n-1)7$ . This gives us  $n = 15$ .  $S_{15} = \frac{15}{2}(10 + 108) = 885$ .
8. We will find  $a_1$  and  $d$  so that we can use the formula  $S_n = \frac{n}{2}[2a_1 + (n-1)d]$ . The information in the problem gives the system  $8 = a_1 + (4-1)d$  and  $56 = a_1 + (10-1)d$ .

$$-a_1 - 3d = -8$$

$$\underline{a_1 + 9d = 56}$$

$$6d = 48$$

$$d = 8$$

$$a_1 + 3(8) = 8 \quad \text{Let } d = 8 \text{ in } a_1 + 3d = 8$$

$$a_1 = -16$$

$$S_{12} = \frac{12}{2}[2(-16) + (12-1)8] = 336$$

## Geometric Sequences

In an arithmetic sequence, the difference of any two consecutive terms is the same, and in a geometric sequence, the quotient of any two consecutive terms is the same. A term in a geometric sequence can be found by multiplying the previous term by a fixed number. For example, the next term in the sequence 1, 2, 4, 8, 16, ... is  $2(16)=32$ , and the term after that is  $2(32)=64$ . This fixed number

is called the *common ratio*. We can define the  $n$ th term of a geometric sequence recursively by  $a_n = r a_{n-1}$ . The general formula is  $a_n = a_1 r^{n-1}$ .

## EXAMPLES

- Determine if the sequence 5, 15, 45, 135, 405, ... is geometric.

We need to see if the ratio of each consecutive pair of numbers is the same.

$$\frac{405}{135} = 3, \quad \frac{135}{45} = 3, \quad \frac{45}{15} = 3, \quad \text{and} \quad \frac{15}{5} = 3$$

The ratio is the same number, so the sequence is geometric.

- Determine if the sequence  $-8, 4, -2, 1, -\frac{1}{2}, \dots$  is geometric.

$$\frac{-1/2}{1} = -\frac{1}{2}, \quad \frac{1}{-2} = -\frac{1}{2}, \quad \frac{-2}{4} = -\frac{1}{2}, \quad \text{and} \quad \frac{4}{-8} = -\frac{1}{2}$$

The ratio is the same number, so the sequence is geometric.

- Determine if the sequence 2430, 729, 240.57, 80.10981, ... is geometric.

$$\frac{80.10981}{240.57} = 0.333 \quad \text{and} \quad \frac{240.57}{729} = 0.33$$

The ratios are different, so this is not a geometric sequence.

- Find the first four terms and the tenth term of the sequence  $a_n = \frac{1}{100}(-5)^{n-1}$ .

$$a_1 = \frac{1}{100} \qquad a_2 = \frac{1}{100}(-5)^{2-1} = -\frac{1}{20}$$

$$a_3 = \frac{1}{100}(-5)^{3-1} = \frac{1}{4} \qquad a_4 = \frac{1}{100}(-5)^{4-1} = -\frac{5}{4}$$

$$a_{10} = \frac{1}{100}(-5)^{10-1} = -\frac{78125}{4}$$

We can find the  $n$ th term of a geometric sequence by either knowing one term and the common ratio or by knowing two terms. This is similar to what we did to find the  $n$ th term of an arithmetic sequence.

## EXAMPLES

Find the  $n$ th term of the geometric sequence.

- The common ratio is 3 and the fourth term is 54.  
 $a_4 = 54$  and  $r = 3$ , so  $a_n = a_1 r^{n-1}$  becomes  $54 = a_1 3^{4-1}$ . This gives us  $a_1 = 2$ . The  $n$ th term is  $a_n = 2(3)^{n-1}$ .



- The third term is 320, and the fifth term is 204.8.  
 $a_3 = 320$  and  $a_5 = 204.8$  give us the system of equations  $320 = a_1r^{3-1}$  and  $204.8 = a_1r^{5-1}$ . Elimination by addition will not work for the systems in this section, so we will use substitution. Solving for  $a_1$  in  $a_1r^2 = 320$  gives us  $a_1 = 320/r^2$ . Substituting this in  $a_1r^4 = 204.8$  gives us the following.

$$a_1r^4 = 204.8$$

$$\frac{320}{r^2} \cdot r^4 = 204.8$$

$$320r^2 = 204.8$$

$$r^2 = 0.64$$

$$r = \pm 0.8$$

There are two geometric sequences whose third term is 320 and whose fifth term is 204.8, one has a common ratio of 0.8 and the other,  $-0.8$ .  $a_1$  for both the sequences is the same.

$$a_1 = \frac{320}{0.8^2} = 500 \quad \text{and} \quad a_1 = \frac{320}{(-0.8)^2} = 500$$

The  $n$ th term for one sequence is  $a_n = 500(0.8)^{n-1}$ , and the other is  $a_n = 500(-0.8)^{n-1}$ .

- The third term is 20, and the sixth term is 81.92.  
 From  $a_3 = 20$  and  $a_6 = 81.92$  we have the system of equations  $20 = a_1r^{3-1}$  and  $81.92 = a_1r^{6-1}$ . We will solve for  $a_1$  in  $20 = a_1r^2$ . Now we will substitute  $a_1 = 20/r^2$  for  $a_1$  in  $81.92 = a_1r^5$ .

$$81.92 = a_1r^5$$

$$81.92 = \frac{20}{r^2} \cdot r^5$$

$$81.92 = 20r^3$$

$$4.096 = r^3$$

$$\sqrt[3]{4.096} = r$$

$$1.6 = r$$

$$a_1 = \frac{20}{1.6^2} = 7.8125$$

The  $n$ th term is  $a_n = 7.8125(1.6)^{n-1}$ .

We can add the first  $n$  terms of a geometric sequence using the following formula (except for  $r = 1$ ).

$$S_n = a_1 \frac{1 - r^n}{1 - r}$$

## EXAMPLES

- Find the sum of the first five terms of the geometric sequence whose  $n$ th term is  $a_n = 3(2)^{n-1}$ ,  $a_1 = 3$  and  $r = 2$ .

$$S_5 = 3 \cdot \frac{1 - 2^5}{1 - 2} = 3 \cdot \frac{-31}{-1} = 93$$

- Compute  $16 + 8 + 4 + 2 + 1 + \frac{1}{2} + \frac{1}{4} + \frac{1}{8} + \frac{1}{16}$   
 $a_1 = 16$ ,  $r = \frac{1}{2}$  and  $n = 9$ .

$$\begin{aligned} S_9 &= 16 \frac{1 - (\frac{1}{2})^9}{1 - \frac{1}{2}} = 16 \frac{\frac{512}{512} - \frac{1}{512}}{\frac{1}{2}} \\ &= 16 \frac{\frac{511}{512}}{\frac{1}{2}} = 16 \left[ \frac{511}{512} \div \frac{1}{2} \right] = 16 \left[ \frac{511}{512} \cdot 2 \right] = \frac{511}{16} \end{aligned}$$

- Find the sum of the first five terms of the geometric sequence whose fourth term is 1.3824 and whose seventh term is 2.3887872.

We need to find  $a_1$  and  $r$ . The terms  $a_4 = 1.3824$  and  $a_7 = 2.3887872$  give us the system of equations  $1.3824 = a_1 r^3$  and  $2.3887872 = a_1 r^6$ . We will solve for  $a_1$  in the first equation and substitute this for  $a_1$  in the second equation.

$$a_1 = \frac{1.3824}{r^3}$$

$$2.3887872 = a_1 r^6$$

$$2.3887872 = \frac{1.3824}{r^3} r^6$$

$$2.3887872 = 1.3824 r^3$$

$$1.728 = r^3$$

$$\sqrt[3]{1.728} = r$$

$$1.2 = r$$

$$a_1 = \frac{1.3824}{1.2^3} = 0.8$$

We have enough information to compute  $S_5$ .

$$S_5 = 0.8 \frac{1 - 1.2^5}{1 - 1.2} = 5.95328$$

- $\sum_{i=1}^6 6.4(1.5)^{i-1}$

We are adding the first six terms of the geometric sequence whose  $n$ th term is  $a_n = 6.4(1.5)^{n-1}$ .

$$\sum_{i=1}^6 6.4(1.5)^{i-1} = S_6 = 6.4 \frac{1 - 1.5^6}{1 - 1.5} = 133$$

- $\sum_{k=0}^7 2(3)^{k-1}$

This problem is tricky because the sum begins with  $k=0$  instead of  $k=1$ . These terms are the first *eight* terms of the geometric sequence  $\frac{2}{3}, 2, 6, 18, 54, 162, 486, 1458, \dots$ . Now we can see that  $n=8$ ,  $a_1 = \frac{2}{3}$  and  $r=3$ .

$$\sum_{k=0}^7 2(3)^{k-1} = S_8 = \frac{2}{3} \cdot \frac{1 - 3^8}{1 - 3} = \frac{6560}{3}$$

- $54 + 18 + 6 + 2 + \frac{2}{3} + \dots + \frac{2}{81}$

We have  $a_1 = 54$  and  $r = \frac{1}{3}$ . We need  $n$  for  $a_n = \frac{2}{81}$ .

$$\frac{2}{81} = 54 \left(\frac{1}{3}\right)^{n-1}$$

$$\frac{1}{2187} = \left(\frac{1}{3}\right)^{n-1}$$

Because  $3^7 = 2187$ ,  $n - 1 = 7$ , so  $n = 8$ .

$$\begin{aligned} 54 + 18 + 6 + 2 + \frac{2}{3} + \cdots + \frac{2}{81} &= 54 \left( \frac{1 - (\frac{1}{3})^8}{1 - \frac{1}{3}} \right) = 54 \left( \frac{\frac{3^8}{3^8} - \frac{1}{3^8}}{\frac{2}{3}} \right) \\ &= 54 \left( \frac{\frac{3^8 - 1}{3^8}}{\frac{2}{3}} \right) = 54 \left( \frac{6560}{6561} \div \frac{2}{3} \right) \\ &= 54 \left( \frac{6560}{6561} \cdot \frac{3}{2} \right) = \frac{6560}{81} \end{aligned}$$

When the common ratio is small enough ( $-1 < r < 1$  and  $r \neq 0$ ), the sum of *all* terms in a geometric sequence is a number. In the finite sum  $S_n = a_1 \frac{1-r^n}{1-r}$ ,  $r^n$  is very small when the ratio is a fraction, so  $1 - r^n$  is very close to 1. Using this fact and calculus techniques (usually learned in a later calculus course), it can be shown that the sum of all terms of this kind of geometric sequence is

$$S = a_1 \frac{1}{1-r}.$$

The only difference between the infinite sum formula and the partial sum formula is that  $1 - r^n$  is replaced by 1. If  $n$  is large enough, there is very little difference between the partial sum and the entire sum. We will compare the sum of the first 20 terms of the sequence whose  $n$ th term is  $a_n = (\frac{1}{2})^{n-1}$  with the sum of all terms.

$$S_{20} = \sum_{n=1}^{20} 1 \cdot \left(\frac{1}{2}\right)^{n-1} = 1 \cdot \frac{1 - (\frac{1}{2})^{20}}{1 - \frac{1}{2}} \approx 1.999998093 \quad \text{and} \quad S = 1 \cdot \frac{1}{1 - \frac{1}{2}} = 2$$

## EXAMPLES

- $\sum_{i=1}^{\infty} 6\left(\frac{2}{3}\right)^{i-1}$   
 $a_1 = 6$ ,  $r = \frac{2}{3}$

$$\sum_{i=1}^{\infty} 6\left(\frac{2}{3}\right)^{i-1} = S = 6 \cdot \frac{1}{1 - \frac{2}{3}} = 6 \cdot \frac{1}{\frac{1}{3}} = 6 \left[ 1 \div \frac{1}{3} \right] = 6 \left[ 1 \cdot \frac{3}{1} \right] = 18$$

$$\bullet \sum_{k=0}^{\infty} 15 \left(\frac{3}{4}\right)^{k-1}$$

We need to be careful with this sum because the sum begins with  $k = 0$  instead of  $k = 1$ . This means that  $a_1$  is not 15 but

$$a_1 = 15 \left(\frac{3}{4}\right)^{0-1} = 15 \left(\frac{3}{4}\right)^{-1} = 15 \left(\frac{4}{3}\right) = 20.$$

The common ratio is  $\frac{3}{4}$ .

$$\sum_{k=0}^{\infty} 15 \left(\frac{3}{4}\right)^{k-1} = S = 20 \cdot \frac{1}{1 - \frac{3}{4}} = 20 \cdot \frac{1}{\frac{1}{4}} = 20 \cdot 4 = 80$$

## PRACTICE

1. What term comes after 18 in the sequence  $\frac{2}{9}, \frac{2}{3}, 2, 6, 18, \dots$ ?
2. Find the first four terms and the tenth term of the geometric sequence whose  $n$ th term is  $a_n = -2(4)^{n-1}$ .
3. Determine if the sequence 900, 90, 9, 0.9, 0.09,  $\dots$  is geometric.
4. Determine if the sequence 9, 99, 999, 9999,  $\dots$  is geometric.
5. Find the  $n$ th term of the geometric sequence(s) whose first term is 9 and whose fifth term is  $\frac{729}{16}$ .
6. Find the  $n$ th term of the geometric sequence whose common ratio is  $-3$  and whose sixth term is  $-1701$ .
7. Find the  $n$ th term of the geometric sequence whose third term is 1 and whose sixth term is  $\frac{27}{8}$ .
8. Compute the sum.

$$\frac{3}{4} + \frac{3}{8} + \frac{3}{16} + \cdots + \frac{3}{256}$$

9.  $\sum_{i=1}^{\infty} \frac{3}{4} \left(\frac{1}{2}\right)^{i-1}$
10.  $\sum_{n=0}^{\infty} -4 \left(\frac{3}{5}\right)^{n-1}$

## SOLUTIONS

- $3(18) = 54$
- $a_1 = -2$ ,  $a_2 = -8$ ,  $a_3 = -32$ ,  $a_4 = -128$  and  $a_{10} = -524, 288$
- The sequence is geometric because the following ratios are the same.

$$\frac{0.09}{0.9} = 0.1, \quad \frac{0.9}{9} = 0.1, \quad \frac{9}{90} = 0.1, \quad \frac{90}{900} = 0.1$$

- The sequence is not geometric because the ratios are not the same.

$$\frac{9999}{999} = \frac{1111}{111} \text{ and } \frac{999}{99} = \frac{111}{11}$$

- Because the fifth term of the sequence is  $\frac{729}{16}$ , we have the equation  $\frac{729}{16} = 9r^{5-1}$ . Once we have solved this equation for  $r$ , we will be done.

$$\begin{aligned} \frac{729}{16} &= 9r^4 \\ \frac{1}{9} \cdot \frac{729}{16} &= r^4 \\ \frac{81}{16} &= r^4 \\ \pm \frac{3}{2} = r & \quad \sqrt[4]{\frac{81}{16}} = \frac{3}{2} \end{aligned}$$

There are two sequences. The  $n$ th term for one of them is  $a_n = 9\left(\frac{3}{2}\right)^{n-1}$  and the other is  $a_n = 9\left(-\frac{3}{2}\right)^{n-1}$ .

- The sixth term is  $-1701$  and  $r = -3$ , which gives us the equation  $-1701 = a_1(-3)^{6-1}$ .

$$\begin{aligned} -1701 &= a_1(-3)^5 \\ -1701 &= -243a_1 \\ 7 &= a_1 \end{aligned}$$

The  $n$ th term is  $a_n = 7(-3)^{n-1}$ .

- The third term is 1 and the sixth term is  $\frac{27}{8}$ , which gives us the system of equations  $1 = a_1r^{3-1}$  and  $\frac{27}{8} = a_1r^{6-1}$ . Solving  $1 = a_1r^2$  for  $a_1$ , we get

$a_1 = 1/r^2$ . We will substitute this in  $\frac{27}{8} = a_1 r^5$ .

$$\frac{27}{8} = \left(\frac{1}{r^2}\right) r^5$$

$$\frac{27}{8} = r^3$$

$$\sqrt[3]{\frac{27}{8}} = r$$

$$\frac{3}{2} = r$$

$$a_1 = \frac{1}{\left(\frac{3}{2}\right)^2} = \left(\frac{2}{3}\right)^2 = \frac{4}{9}$$

The  $n$ th term is  $a_n = \frac{4}{9}\left(\frac{3}{2}\right)^{n-1}$ .

8.  $a_1 = \frac{3}{4}$  and  $r = \frac{1}{2}$ . We know  $a_n = \frac{3}{256}$  but we need  $n$ . We will solve  $\frac{3}{256} = \frac{3}{4}\left(\frac{1}{2}\right)^{n-1}$  for  $n$ .

$$\frac{3}{256} = \frac{3}{4}\left(\frac{1}{2}\right)^{n-1}$$

$$\frac{4}{3} \cdot \frac{3}{256} = \left(\frac{1}{2}\right)^{n-1}$$

$$\frac{1}{64} = \left(\frac{1}{2}\right)^{n-1}$$

Because  $2^6 = 64$ ,  $n - 1 = 6$ , so  $n = 7$ . Now we can find the sum.

$$\begin{aligned} S_7 &= \frac{3}{4} \cdot \frac{1 - \left(\frac{1}{2}\right)^7}{1 - \frac{1}{2}} = \frac{3}{4} \cdot \frac{\frac{128-1}{128}}{\frac{1}{2}} = \frac{3}{4} \left(\frac{127}{128} \div \frac{1}{2}\right) \\ &= \frac{3}{4} \left(\frac{127}{128} \cdot \frac{2}{1}\right) = \frac{381}{256} \end{aligned}$$

9.  $a_1 = \frac{3}{4}$  and  $r = \frac{1}{2}$ . This is all we need for the infinite sum formula.

$$S = \frac{3}{4} \cdot \frac{1}{1 - \frac{1}{2}} = \frac{3}{4} \cdot \frac{1}{\frac{1}{2}} = \frac{3}{4} \left(1 \div \frac{1}{2}\right) = \frac{3}{4} \cdot (1 \cdot 2) = \frac{3}{2}$$

10.  $a_1$  is not  $-4$  because the sum begins at  $n = 0$  instead of  $n = 1$ .

$$a_1 = -4 \left(\frac{3}{5}\right)^{0-1} = -4 \left(\frac{3}{5}\right)^{-1} = -4 \left(\frac{5}{3}\right) = -\frac{20}{3}$$

Now we can add all of the terms of the geometric sequence whose  $n$ th term is  $a_n = -\frac{20}{3}\left(\frac{3}{5}\right)^{n-1}$ .

$$S = -\frac{20}{3} \cdot \frac{1}{1 - \frac{3}{5}} = -\frac{20}{3} \cdot \frac{1}{\frac{2}{5}} = -\frac{20}{3} \left(1 \div \frac{2}{5}\right) = -\frac{20}{3} \left(1 \cdot \frac{5}{2}\right) = -\frac{50}{3}$$

When regular payments are made to a savings account or to a lottery winner, the monthly balances act like terms in a geometric sequence. The common ratio is either  $1 + i$  (for savings payments) or  $(1 + i)^{-1}$  (for lottery payments), where  $i$  is the interest rate per payment period. We learned in Chapter 9 that if we leave  $P$  dollars in an account, earning annual interest  $r$ , compounded  $n$  times per year, for  $t$  years, then this will grow to  $A$  dollars where  $A = P(1 + r/n)^{nt}$ . (This is why  $i$  replaces  $r/n$ .)

We will see what happens to the balance of an account if \$2000 is deposited on January 1 every year for 5 years, earning 10% per year, compounded annually. The first \$2000 will earn interest for the entire 5 years, so it will grow to  $2000(1 + 0.10/1)^5 = 2000(1.10)^5$ . The second \$2000 will earn interest for 4 years, so it will grow to  $2000(1.10)^4$ . The third \$2000 will earn interest for 3 years, so it will grow to  $2000(1.10)^3$ . The fourth \$2000 will earn interest for 2 years, so it will grow to  $2000(1.10)^2$ . And the fifth \$2000 will earn interest for 1 year, so it will grow to  $2000(1.10)^1$ . The balance after five years is

$$2000(1.10)^5 + 2000(1.10)^4 + 2000(1.10)^3 + 2000(1.10)^2 + 2000(1.10)^1.$$

This is the sum of the first five terms of the geometric sequence whose  $n$ th term is  $a_n = 2000(1.10)^n$ . If we want to use the partial sum formula, we need to rewrite the  $n$ th term in the form  $a_n = a_1 r^{n-1}$ . We will use exponent properties to change  $2000(1.10)^n$  to  $a_1(1.10)^{n-1}$ . We will also use the fact that  $n = 1 + n - 1$ .

$$\begin{aligned} 2000(1.10)^n &= 2000(1.10)^{1+n-1} = 2000(1.10)^1(1.10)^{n-1} \\ &= [2000(1.10)](1.10)^{n-1} = 2200(1.10)^{n-1} \end{aligned}$$

Now we can use the partial sum formula.

$$S_5 = 2200 \cdot \frac{1 - 1.10^5}{1 - 1.10} = 13,431.22$$

The balance in the account will be \$13,431.22.



When a lottery winner wins a \$1,000,000 jackpot, the money is likely to be paid out in \$50,000 annual payments for 20 years. Some states allow the winner to take the *cash value* as a lump sum payment instead. The cash value is the present value of \$1,000,000 to be paid in annual payments over 20 years. The formula for the present value of  $A$  dollars, due in  $t$  years, earning annual interest  $r$ , compounded  $n$  times per year is  $A(1 + r/n)^{-nt}$ . Assume that the money is expected to earn 5% per year. Then the cash value of the jackpot will need to be enough money so that at the beginning of the year (for a payment at the end of the year), they have  $50,000(1.05)^{-1}$ . For a payment at the end of two years, they need  $50,000(1.05)^{-2}$ ; at the end of three years, they need  $50,000(1.05)^{-3}$ , and so on until they reach the last payment after 20 years,  $50,000(1.05)^{-20}$ . In other words, the cash value of a \$1,000,000 jackpot with a 20-year payout (assuming 5% interest) is

$$50,000(1.05)^{-1} + 50,000(1.05)^{-2} + 50,000(1.05)^{-3} + \cdots + 50,000(1.05)^{-20}.$$

This is the sum of the first 20 terms of the geometric sequence whose  $n$ th term is  $a_n = 50,000(1.05)^{-n}$ . We need to use exponent properties to rewrite the  $n$ th term in the form  $a_n = a_1 r^{n-1}$ . We will use the fact that  $-n = -n - 1 + 1$  and the exponent facts that  $x^{m+n} = x^m x^n$  and  $x^{mn} = (x^m)^n$ .

$$\begin{aligned} 1.05^{-n} &= 1.05^{-n+1-1} = 1.05^{-1} \cdot 1.05^{-n+1} = 1.05^{-1} \cdot 1.05^{-1(n-1)} \\ &= 1.05^{-1} \cdot (1.05^{-1})^{n-1} \end{aligned}$$

Now the  $n$ th term can be written as  $a_n = [50,000(1.05)^{-1}](1.05^{-1})^{n-1}$ , where  $a_1 = 50,000(1.05)^{-1}$ . Now we can use the partial sum formula.

$$S_{20} = [50,000(1.05)^{-1}] \cdot \frac{1 - (1.05^{-1})^{20}}{1 - 1.05^{-1}} \approx 623,110.51$$

The cash value is \$623,110.51.

## CHAPTER 14 REVIEW

1. What term comes next in the sequence?

$$\frac{2}{5}, \frac{3}{6}, \frac{4}{7}, \frac{5}{8}, \frac{6}{9}, \dots$$

(a)  $\frac{7}{10}$

(b)  $\frac{7}{11}$

(c)  $\frac{8}{11}$

(d)  $\frac{8}{10}$

2. What is the fourth term of the sequence whose  $n$ th term is  $a_n = (-1)^{n+1}(\frac{2}{3})^n$ ?
- (a)  $\frac{16}{81}$       (b)  $-\frac{16}{81}$       (c)  $\frac{8}{3}$       (d)  $-\frac{8}{3}$
3. The terms in the sequence 6, 2, -4, -6, -2, 4, ... can be found using which formula?
- (a)  $a_n = a_{n-2} - a_{n-1}, a_1 = 6$  and  $a_2 = 2$   
 (b)  $a_n = 6 + (n - 1)4$   
 (c)  $a_n = a_{n-1} - a_{n-2}, a_1 = 6$  and  $a_2 = 2$   
 (d) There is no formula that works.
4. Is the sequence in Problem 3 arithmetic, geometric, or neither?
- (a) Arithmetic  
 (b) Geometric  
 (c) Neither  
 (d) There are not enough terms to tell.
5. Is the sequence  $\frac{3}{4}, \frac{1}{4}, \frac{1}{12}, \frac{1}{36}, \dots$  arithmetic, geometric, or neither?
- (a) Arithmetic  
 (b) Geometric  
 (c) Neither  
 (d) There are not enough terms to tell.
6. What is the third term of the arithmetic sequence whose 17th term is 9 and whose 21st term is 12?
- (a)  $-\frac{3}{2}$       (b)  $-\frac{4}{5}$       (c)  $\frac{5}{2}$       (d)  $-\frac{2}{5}$
7. What is the eighth term of the geometric sequence whose third term is  $\frac{5}{4}$  and whose sixth term is 10?
- (a) 36      (b) 40      (c) 45      (d) 49
8. Find the sum.

$$-\frac{2}{3} + \frac{5}{6} + \frac{7}{3} + \frac{23}{6} + \dots + \frac{59}{6}$$

- (a)  $\frac{116}{3}$       (b)  $\frac{110}{3}$       (c)  $\frac{58}{3}$   
 (d) Too many terms are missing to find the sum.

9. Find the sum.

$$\frac{4}{9} + \frac{2}{9} + \frac{1}{9} + \frac{1}{18} + \cdots + \frac{1}{144}$$

(a)  $\frac{127}{36}$                       (b)  $\frac{127}{81}$                       (c)  $\frac{127}{144}$

(d) Too many terms are missing to find the sum.

10. Find the sum.

$$\sum_{i=1}^{\infty} 5 \left( \frac{3}{5} \right)^{i-1}$$

(a)  $\frac{25}{2}$                       (b)  $\frac{75}{2}$                       (c)  $\frac{5}{2}$

(d) There are too many numbers to add.

## SOLUTIONS

- |      |      |      |      |       |
|------|------|------|------|-------|
| 1. A | 2. B | 3. C | 4. C | 5. B  |
| 6. A | 7. B | 8. B | 9. C | 10. A |



# Appendix

## Solving Equations and Inequalities

Using algebra to solve equations and inequalities is important in precalculus and calculus. Usually the solution to an equation is a number or numbers. Sometimes, the solution to an equation is simply the equation written another way. To solve for  $x$  means to have  $x$ , and  $x$  only, on one side of the equation. The equation  $x = \frac{y-5}{y^2+1}$  is solved for  $x$  but  $x = \frac{y-5}{x^2+1}$  is not solved for  $x$  because  $x$  is on both sides of the equation. Solving for  $x$  when the equation contains more than one variable is very much like solving for  $x$  when the equation has only one variable. We move quantities from one side of the equation by adding, subtracting, multiplying, and dividing.

- Solve for  $x$  in the equation  $a(x + 4) - 2a(x - 1) = 5(a + x)$ .

$$a(x + 4) - 2a(x - 1) = 5(a + x) \quad \text{Simplify both sides of the equation.}$$

$$ax + 4a - 2ax + 2a = 5a + 5x$$

$$ax - 2ax + 6a = 5a + 5x \quad \text{Move } x \text{ terms to one side of the equation.}$$

$$ax - 2ax - 5x + 6a = 5a \quad \text{Move terms without } x \text{ to the other side.}$$

$$ax - 2ax - 5x = -6a + 5a \quad \text{Simplify both sides.}$$

$$-ax - 5x = -a \quad \text{Factor } x.$$

$$x(-a - 5) = -a \quad \text{Divide both sides by } -a - 5$$

$$x = \frac{-a}{-a - 5} \text{ or } \frac{a}{a + 5}$$

## Quadratic Equations

Equations of the form  $ax^2 + bx + c = 0$  (where  $a \neq 0$ ) are *quadratic equations*. There are several techniques we can use to solve them, factoring, completing the square, and the quadratic formula. The simplest quadratic equations are in the form  $x^2 = \text{number}$ . This equation has solutions  $x = \sqrt{\text{number}}$  and  $x = -\sqrt{\text{number}}$ , or simply,  $x = \pm\sqrt{\text{number}}$ . For example, the solutions for  $x^2 = 36$  are  $x = 6$  and  $x = -6$ , or  $x = \pm 6$ .

Many quadratic equations can be solved by factoring. When there is a zero on one side of the equation, we factor the other side, set each factor equal to zero and solve both equations. This method comes from the fact that  $ab = 0$  implies  $a = 0$  or  $b = 0$ .

- $x^2 + x - 6 = 0$

$x^2 + x - 6$  factors as  $(x + 3)(x - 2)$ . Set each of  $x + 3$  and  $x - 2$  equal to 0 and solve for  $x$ .

$$x + 3 = 0 \quad x - 2 = 0$$

$$x = -3 \quad x = 2$$

- $3x^2 + 24 = -18x$

We need a zero on one side of the equation, so we will move  $18x$  to the other side.

$$3x^2 + 18x + 24 = 0$$

$$3(x^2 + 6x + 8) = 0$$

$$3(x + 2)(x + 4) = 0$$

$$x + 2 = 0 \quad x + 4 = 0$$

$$x = -2 \quad x = -4$$

Some quadratic equations are difficult to factor. The quadratic formula can solve *every* quadratic equation. If  $a \neq 0$  and  $ax^2 + bx + c = 0$ , then

$$x = \frac{-b \pm \sqrt{b^2 - 4ac}}{2a}.$$

- $3x^2 - x - 4 = 0$

$$a = 3, b = -1, \text{ and } c = -4$$

$$\begin{aligned} x &= \frac{-(-1) \pm \sqrt{(-1)^2 - 4(3)(-4)}}{2(3)} = \frac{1 \pm \sqrt{49}}{6} = \frac{1 \pm 7}{6} \\ &= \frac{8}{6}, \frac{-6}{6} = \frac{4}{3}, -1 \end{aligned}$$

- $x^2 - 1 = 0$

$$a = 1, b = 0, \text{ and } c = -1$$

$$x = \frac{-0 \pm \sqrt{0^2 - 4(1)(-1)}}{2(1)} = \frac{\pm\sqrt{4}}{2} = \frac{\pm 2}{2} = \pm 1$$

- $4x^2 + x = 1$

We need 0 on one side of the equation. Once we move 1 to the other side, we have  $4x^2 + x - 1 = 0$ .

$$x = \frac{-1 \pm \sqrt{1^2 - 4(4)(-1)}}{2(4)} = \frac{-1 \pm \sqrt{17}}{8}$$

A quadratic equation can have square roots of numbers as solutions that need to be simplified. The square root of a number is simplified when it does not have any perfect squares as factors. For example,  $\sqrt{24}$  is not simplified because  $24 = 2^2 \times 6$ . We can use the exponent properties  $\sqrt{ab} = \sqrt{a} \cdot \sqrt{b}$  and  $\sqrt[n]{a^n} = a$  to simplify  $\sqrt{24}$ .

$$\sqrt{24} = \sqrt{4 \cdot 6} = \sqrt{4} \cdot \sqrt{6} = 2\sqrt{6}$$

Square roots of fractions and square roots in denominators are also not considered simplified. These numbers often come up in trigonometry. Sometimes we can multiply the fraction by the denominator over itself.

- $\sqrt{\frac{1}{3}} = \frac{\sqrt{1}}{\sqrt{3}} = \frac{1}{\sqrt{3}} = \frac{1}{\sqrt{3}} \cdot \frac{\sqrt{3}}{\sqrt{3}} = \frac{\sqrt{3}}{(\sqrt{3})^2} = \frac{\sqrt{3}}{3}$

- $\frac{10}{\sqrt{5}} = \frac{10}{\sqrt{5}} \cdot \frac{\sqrt{5}}{\sqrt{5}} = \frac{10\sqrt{5}}{(\sqrt{5})^2} = \frac{10\sqrt{5}}{5} = 2\sqrt{5}$

This trick will not work for expressions such as  $\frac{2}{\sqrt{3}+1}$ . To simplify these fractions, we will use the fact that  $(a - b)(a + b) = a^2 - b^2$ . This allows us to square each term in the denominator individually. The denominator is in the form  $a + b$  (where  $a = \sqrt{3}$  and  $b = 1$ ). We will multiply the fraction by  $a - b$  over itself.

$$\begin{aligned}\frac{2}{\sqrt{3} + 1} &= \frac{2}{\sqrt{3} + 1} \cdot \frac{\sqrt{3} - 1}{\sqrt{3} - 1} \\ &= \frac{2(\sqrt{3} - 1)}{(\sqrt{3})^2 - 1^2} = \frac{2(\sqrt{3} - 1)}{3 - 1} \\ &= \frac{2(\sqrt{3} - 1)}{2} = \sqrt{3} - 1\end{aligned}$$

- $\frac{-8}{2-\sqrt{5}}$

The denominator is in the form  $a - b$  (with  $a = 2$  and  $b = \sqrt{5}$ ). We will multiply the fraction by  $a + b$  over itself.

$$\begin{aligned}\frac{-8}{2 - \sqrt{5}} &= \frac{-8}{2 - \sqrt{5}} \cdot \frac{2 + \sqrt{5}}{2 + \sqrt{5}} \\ &= \frac{-8(2 + \sqrt{5})}{2^2 - (\sqrt{5})^2} = \frac{-8(2 + \sqrt{5})}{4 - 5} \\ &= \frac{-8(2 + \sqrt{5})}{-1} = 8(2 + \sqrt{5}) = 16 + 8\sqrt{5}\end{aligned}$$

## Factoring by Grouping

Some expressions of the form  $ax^3 + bx^2 + cx + d$  can be factored using a technique called *factoring by grouping*. This technique takes two steps. The first step is to factor the first two terms and the second two terms so that each pair of terms has a common factor. The second step is to factor this common factor. For example, if we factor  $x^2$  from the first two terms of  $x^3 + 2x^2 + 3x + 6$ , we are left with  $x^2(x + 2) + 3x + 6$ . Now we look at the second two terms,  $3x + 6$ , and factor it so that  $x + 2$  is a factor. If we factor 3 from  $3x + 6$ , we are left with  $x + 2$  as

a factor:  $3x + 6 = 3(x + 2)$ . This leaves us with  $x^2(x + 2) + 3(x + 2)$ . In the last step, we factor  $x + 2$  from each term, leaving  $x^2$  and 3.

$$\begin{aligned}x^3 + 2x^2 + 3x + 6 &= x^2(x + 2) + 3(x + 2) \\ &= (x + 2)(x^2 + 3)\end{aligned}$$

We can use this technique to solve equations.

- $4x^3 - 5x^2 - 36x + 45 = 0$   
Once we have factored  $4x^3 - 5x^2 - 36x + 45$ , we will set each factor equal to 0 and solve for  $x$ . If we factor  $x^2$  from the first two terms, we have  $4x^3 - 5x^2 = x^2(4x - 5)$ . If we factor  $-9$  from the second two terms, we have  $-36x + 45 = -9(4x - 5)$ .

$$\begin{aligned}4x^3 - 5x^2 - 36x + 45 &= 0 \\ x^2(4x - 5) - 9(4x - 5) &= 0 \\ (4x - 5)(x^2 - 9) &= 0\end{aligned}$$

$$\begin{aligned}4x - 5 = 0 & & x^2 - 9 = 0 \\ 4x = 5 & & x^2 = 9 \\ x = \frac{5}{4} & & x = \pm 3\end{aligned}$$

## Solving $ax^n = b$ and $a\sqrt[n]{x} = b$

Solve equations of the form  $ax^n = b$  by first dividing both sides of the equation by  $a$ , then by taking the  $n$ th root of both sides. If  $n$  is even, use a  $\pm$  symbol on one side of the equation to get both solutions.

- $4x^2 = 9$   
 $x^2 = \frac{9}{4}$   
 $x = \pm\sqrt{\frac{9}{4}} = \pm\frac{3}{2}$





## Appendix

- $8x^3 = -1$

$$x^3 = -\frac{1}{8}$$

$$x = \sqrt[3]{-\frac{1}{8}} = -\frac{1}{2}$$

Solve equations of the form  $a\sqrt[n]{x} = b$  by first dividing both sides of the equation by  $a$ , then by raising both sides to the  $n$ th power.

- $4\sqrt{x} = 5$

$$4\sqrt{x} = 5$$

$$\sqrt{x} = \frac{5}{4}$$

$$(\sqrt{x})^2 = \left(\frac{5}{4}\right)^2$$

$$x = \frac{25}{16}$$

- $4\sqrt{x} - 3 = 0$

This equation needs to be in the form  $a\sqrt{x} = b$  before we square both sides of the equation.

$$4\sqrt{x} - 3 = 0$$

$$4\sqrt{x} = 3$$

$$\sqrt{x} = \frac{3}{4}$$

$$(\sqrt{x})^2 = \left(\frac{3}{4}\right)^2$$

$$x = \frac{9}{16}$$

## Inequalities

Solving linear inequalities is much like solving linear equations *except* when multiplying or dividing both sides of the inequality by a negative number, when we must reverse the inequality symbol. Solutions to inequalities are usually given

## Appendix

in interval notation. The last page of the appendix has a review of interval notation.

- $5x - 8 > 3x + 10$

$$5x - 8 > 3x + 10$$

$$2x > 18$$

$$x > 9$$

The solution is  $(9, \infty)$ .

- $3x + 7 \leq 5x - 9$

$$3x + 7 \leq 5x - 9$$

$$-2x \leq -16$$

$$\frac{-2x}{-2} \geq \frac{-16}{-2}$$

Reverse the sign at this step.

$$x \geq 8$$

The solution is  $[8, \infty)$ .

A double inequality is notation for two separate inequalities. They are solved the same way as single inequalities.

- $-3 \leq \frac{4x+7}{2} \leq 5$

This inequality means  $-3 \leq \frac{4x+7}{2}$  and  $\frac{4x+7}{2} \leq 5$ .

$$-3 \leq \frac{4x+7}{2} \leq 5$$

Clear the fraction by multiplying all three quantities by 2.

$$-6 \leq 4x + 7 \leq 10$$

Subtract 7 from all three quantities.

$$-13 \leq 4x \leq 3$$

Divide all three quantities by 4.

$$\frac{-13}{4} \leq x \leq \frac{3}{4}$$

The solution is  $[-13/4, 3/4]$ .

Nonlinear inequalities are solved in a different way. Below is a list of steps we will take to solve polynomial inequalities.

1. Rewrite the expression with 0 on one side.
2. Factor the nonzero side.
3. Set each factor equal to 0 and solve for  $x$ .

4. Put these solutions from Step 3 on a number line.
  5. Pick a number to the left of the smallest solution (from Step 3), a number between consecutive solutions, and a number to the right of the largest solution.
  6. Put these numbers in for  $x$  in the original inequality.
  7. If a number makes the inequality true, mark “True” over the interval. If a number makes the inequality false, mark “False” over the interval.
  8. Write the interval notation for the “True” intervals.
- $2x^2 - x \geq 3$

$$2x^2 - x - 3 \geq 0 \quad \text{Step 1}$$

$$(2x - 3)(x + 1) \geq 0 \quad \text{Step 2}$$

$$2x - 3 = 0 \quad x + 1 = 0 \quad \text{Step 3}$$

$$x = \frac{3}{2} \quad x = -1$$

**Step 4** Put  $-1$  and  $3/2$  on a number line.

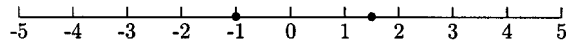

Fig. A.1.

**Step 5** We will use  $x = -2$  for the number to the left of  $-1$ ,  $x = 0$  for the number between  $-1$  and  $3/2$ , and  $x = 2$  for the number to the right of  $3/2$ .

**Step 6** We will test these numbers in  $2x^2 - x \geq 3$ .

$$\text{Let } x = -2 \quad 2(-2)^2 - (-2) \geq 3? \quad \text{True}$$

$$\text{Let } x = 0 \quad 2(0)^2 - 0 \geq 3? \quad \text{False}$$

$$\text{Let } x = 2 \quad 2(2)^2 - 2 \geq 3? \quad \text{True}$$

**Step 7** We will mark the interval to the left of  $-1$  “True,” the interval between  $-1$  and  $3/2$  “False,” and the interval to the right of  $3/2$ , “False.”

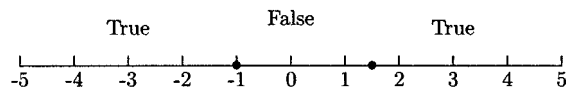

Fig. A.2.

**Step 8** The intervals that make the inequality true are  $x \leq -1$  and  $x \geq 3/2$ . The interval notation is  $(-\infty, -1] \cup [3/2, \infty)$ .

If there is an  $x$  in a denominator, the steps change slightly.

1. Get 0 on one side of the inequality.
  2. Write the nonzero side as one fraction.
  3. Factor the numerator and the denominator.
  4. Set each factor equal to 0 and solve for  $x$ .
  5. Put these solutions from Step 4 on a number line.
  6. Pick a number to the left of the smallest solution (from Step 4), a number between consecutive solutions, and a number to the right of the largest solution.
  7. Put these numbers in for  $x$  in the original inequality.
  8. If a number makes the inequality true, mark “True” over the interval. If a number makes the inequality false, mark “False” over the interval.
  9. Write the interval notation for the “True” intervals—make sure that the solution does not include any  $x$ -value that makes a denominator 0.
- $\frac{x-4}{x+5} > 2$

$$\frac{x-4}{x+5} > 2$$

$$\frac{x-4}{x+5} - 2 > 0 \quad \text{Step 1}$$

$$\frac{x-4}{x+5} - 2 \left( \frac{x+5}{x+5} \right) > 0 \quad \text{Step 2}$$

$$\frac{x-4-2(x+5)}{x+5} > 0$$

$$\frac{-x-14}{x+5} > 0$$

$$-x-14=0 \quad x+5=0 \quad \text{Step 4}$$

$$x=-14 \quad x=-5$$

Step 5

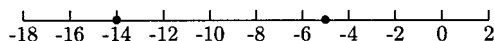

Fig. A.3.

**Step 6** We will use  $x = -15$  for the number to the left of  $-14$ ,  $x = -10$  for the number between  $-14$  and  $-5$ , and  $x = 0$  for the number to the right of  $-5$ .

## Step 7

$$\frac{-15 - 4}{-15 + 5} > 2? \quad \text{False}$$

$$\frac{-10 - 4}{-10 + 5} > 2? \quad \text{True}$$

$$\frac{0 - 4}{0 + 5} > 2? \quad \text{False}$$

We will write “False” over the interval to the left of  $-14$ , “True” over the interval between  $-14$  and  $-5$ , and “False” over the interval to the right of  $-5$ .

## Step 8

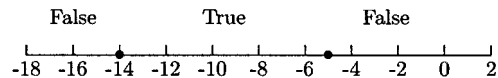

Fig. A.4.

The solution is the interval  $(-14, -5)$ .

- $\frac{x^2 - 3x}{x + 1} \leq -1$

$$\frac{x^2 - 3x}{x + 1} \leq -1$$

$$\frac{x^2 - 3x}{x + 1} + 1 \leq 0$$

$$\frac{x^2 - 3x}{x + 1} + 1 \cdot \frac{x + 1}{x + 1} \leq 0$$

$$\frac{x^2 - 3x + x + 1}{x + 1} \leq 0$$

$$\frac{x^2 - 2x + 1}{x + 1} \leq 0$$

$$\frac{(x - 1)(x - 1)}{x + 1} \leq 0$$

$$x - 1 = 0 \quad x + 1 = 0$$

$$x = 1 \quad x = -1$$

$$\frac{(-2)^2 - 3(-2)}{-2 + 1} \leq -1? \quad \text{True}$$

$$\frac{0^2 - 3(0)}{0 + 1} \leq -1? \quad \text{False}$$

$$\frac{2^2 - 3(2)}{2 + 1} \leq -1? \quad \text{False}$$

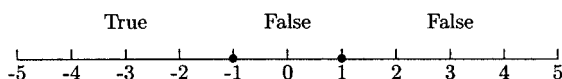
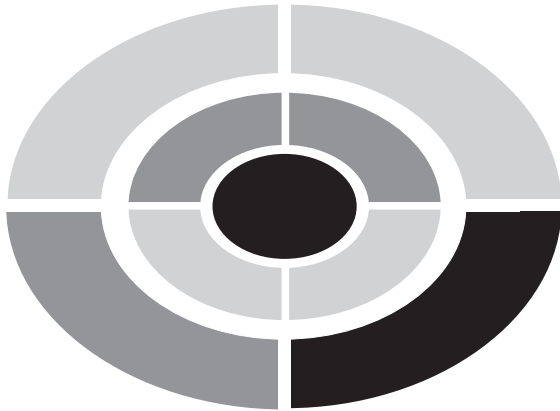

**Fig. A.5.**

The solution is  $(-\infty, -1)$ . The solution is *not*  $(-\infty, -1]$  because a bracket next to  $-1$  indicates that  $-1$  is part of the solution. We cannot allow  $x = -1$  because we would have a zero in a denominator.

**Table. A.1**

Inequality	Number Line	Interval
$x < a$	 a <b>Fig. A.6</b>	$(-\infty, a)$
$x \leq a$	 a <b>Fig. A.7</b>	$(-\infty, a]$
$x > a$	 a <b>Fig. A.8</b>	$(a, \infty)$
$x \geq a$	 a <b>Fig. A.9</b>	$[a, \infty)$
$a < x < b$	 a                      b <b>Fig. A.10</b>	$(a, b)$
$a \leq x \leq b$	 a                      b <b>Fig. A.11</b>	$[a, b]$
$x < a$ or $x > b$	 a                      b <b>Fig. A.12</b>	$(-\infty, a) \cup (b, \infty)$
$x \leq a$ or $x \geq b$	 a                      b <b>Fig. A.13</b>	$(-\infty, a] \cup [b, \infty)$
All $x$	All real numbers	$(-\infty, \infty)$



# Final Exam

1. What is the maximum or minimum functional value for  $f(x) = -(x - 5)^2 + 12$ ?
  - (a) The maximum functional value is 12.
  - (b) The maximum functional value is 5.
  - (c) The minimum functional value is 12.
  - (d) The maximum functional value is 5.

2. Find an equation of the line containing the points  $(1, 9/2)$  and  $(-2, 6)$ .
  - (a)  $y = \frac{1}{2}x + 8$
  - (b)  $y = \frac{7}{16}x + \frac{9}{2}$
  - (c)  $y = -\frac{1}{2}x + 5$
  - (d)  $y = \frac{7}{16}x + 6$

3. What is (are) the vertical asymptote(s) for the graph of

$$f(x) = \frac{x + 5}{x - 3}?$$

- (a)  $x = 3$
- (b)  $x = -5$
- (c)  $x = 3$  and  $x = -5$
- (d) There are no vertical asymptotes.

4. Find the product.

$$\begin{bmatrix} 1 & -1 \\ 0 & 2 \end{bmatrix} \cdot \begin{bmatrix} -5 & 1 & 3 \\ 2 & 2 & 1 \end{bmatrix}$$

(a)  $\begin{bmatrix} -3 & 3 & 4 \\ -4 & -4 & -2 \end{bmatrix}$

(b)  $\begin{bmatrix} -7 & -1 & 2 \\ 4 & 4 & 2 \end{bmatrix}$

(c)  $\begin{bmatrix} -5 & -1 \\ 0 & 4 \end{bmatrix}$

(d) The product does not exist.

5.  $\cos 7\pi/6 =$

(a)  $1/2$

(b)  $-1/2$

(c)  $\sqrt{3}/2$

(d)  $-\sqrt{3}/2$

6. What are the foci for the hyperbola

$$\frac{(y - 1)^2}{16} - \frac{(x + 1)^2}{9} = 1?$$

(a)  $(-1, -4)$  and  $(-1, 6)$

(b)  $(-6, 1)$  and  $(4, 1)$

(c)  $(-4, -1)$  and  $(6, -1)$

(d)  $(1, -6)$  and  $(1, 4)$

7. Find  $x + y$  for the system.

$$\begin{cases} x - 2y = 1 \\ 2x + y = 7 \end{cases}$$

(a) 4

(b) 5

(c) 6

(d) 7

8. Find the fourth term of the arithmetic sequence whose 30th term is  $-180$  and whose 45th term is  $-300$ .

(a) 20

(b) 28

(c) 35

(d) 46

9. If \$2000 is deposited into an account earning 9% annual interest, compounded monthly, what is it worth after 10 years?

(a) \$4902.71

(b) \$4734.73

(c) \$2155.17

(d) \$4870.38

10. For  $f(x) = 1 - x^2$  and  $g(x) = 2x + 5$ , what is  $f \circ g(x)$ ?

(a)  $-2x^2 + 3$

(b)  $\frac{1-x^2}{2x+5}$

(c)  $-4x^2 - 20x - 24$

(d)  $-2x^3 - 5x^2 + 2x + 5$

11. Evaluate  $f(2)$  for  $f(x) = 7$ .

(a) 2

(b) 7

(c) 14

(d) 2, 7

12. Find  $\cos \theta$  if  $\sin \theta = -4/5$  and  $\theta$  is in Quadrant IV.

(a)  $3/5$

(b)  $-3/5$

(c)  $9/25$

(d)  $-9/25$



13. What is the directrix for the parabola  $y^2 = 12(x - 3)$ ?  
 (a)  $y = -3$       (b)  $y = 3$       (c)  $x = 0$       (d)  $x = 3$
14. Are the lines  $2x - y = 5$  and  $4x - 8y = 9$  parallel, perpendicular, or neither?  
 (a) Parallel      (b) Perpendicular  
 (c) Neither      (d) Cannot be determined
15. Find the second term of the arithmetic sequence whose fifth term is  $\frac{122}{3}$  and whose tenth term is  $\frac{272}{3}$ .  
 (a)  $\frac{5}{6}$       (b)  $\frac{14}{3}$       (c)  $\frac{25}{16}$       (d)  $\frac{32}{3}$
16. What is the domain for  $f(x) = \sqrt[3]{x+1}$ ?  
 (a)  $(-\infty, -1) \cup (-1, \infty)$       (b)  $(-1, \infty)$   
 (c)  $[-1, \infty)$       (d)  $(-\infty, \infty)$
17. Find  $f \circ g(-2)$  for  $f(x) = x^2 + x$  and  $g(x) = 3x + 9$ .  
 (a) 12      (b) 15      (c) 3      (d) 2
18. What is the vertex for  $y = 4x^2 - 6x + 5$ ?  
 (a)  $(\frac{3}{2}, 5)$       (b)  $(\frac{3}{4}, \frac{11}{4})$       (c)  $(3, -4)$       (d)  $(3, 14)$
19. What is the inverse of  $\begin{bmatrix} -10 & 1 \\ 5 & 2 \end{bmatrix}$ ?  
 (a)  $\begin{bmatrix} -\frac{2}{25} & \frac{1}{25} \\ \frac{1}{5} & \frac{2}{5} \end{bmatrix}$       (b)  $\begin{bmatrix} \frac{1}{25} & -\frac{2}{25} \\ \frac{2}{5} & \frac{1}{5} \end{bmatrix}$   
 (c)  $\begin{bmatrix} -\frac{1}{25} & \frac{2}{25} \\ -\frac{2}{5} & -\frac{1}{5} \end{bmatrix}$       (d)  $\begin{bmatrix} \frac{1}{25} & \frac{2}{25} \\ \frac{2}{5} & -\frac{1}{5} \end{bmatrix}$
20. What is the fifth term of the sequence where  $a_n = n^2$ ?  
 (a) 10      (b) 15      (c) 20      (d) 25
21. What is an asymptote for the hyperbola

$$\frac{(x+1)^2}{9} - \frac{(y-1)^2}{16} = 1?$$

- (a)  $y = \frac{3}{4}x + \frac{7}{4}$       (b)  $y = \frac{4}{3}x + \frac{1}{3}$   
 (c)  $y = \frac{4}{3}x + \frac{7}{3}$       (d)  $y = \frac{3}{4}x - \frac{1}{4}$
22. What is the phase shift for  $y = 3 \sin(2x - \pi/3)$ ?  
 (a)  $-\pi/3$       (b)  $\pi/3$       (c)  $-\pi/6$       (d)  $\pi/6$

23. What is the period for  $y = 3 \sin(2x - \pi/3)$ ?  
 (a)  $\pi$                       (b)  $\pi/4$                       (c)  $4\pi$                       (d)  $\pi/2$
24. Find  $2x + y$  for the system.

$$\begin{cases} y = x^2 - x - 8 \\ y = 2x + 10 \end{cases}$$

- (a) 3 and 16                      (b) 5 and 21                      (c) 1 and 28                      (d) 3 and 9
25.  $\log_5 5^{2t} =$   
 (a)  $t$                       (b)  $2t$                       (c) 2                      (d)  $10t$
26. What is the horizontal asymptote for the graph of

$$f(x) = \frac{3x^2 + 2x + 1}{6x^2 + 3x + 4}?$$

- (a)  $y = 0$                       (b)  $y = \frac{1}{2}$                       (c) There is no horizontal asymptote.
27. Is the sequence  $-\frac{8}{3}, -\frac{13}{6}, -\frac{5}{3}, -\frac{7}{6}, -\frac{2}{3}, \dots$  arithmetic, geometric, or neither?  
 (a) Arithmetic                      (b) Geometric  
 (c) Neither                      (d) Cannot be determined

28. What is the inverse of  $\begin{bmatrix} 1 & 1 & 1 \\ 2 & -1 & 1 \\ -1 & 1 & -3 \end{bmatrix}$ ?

(a)  $\begin{bmatrix} \frac{5}{8} & -\frac{1}{4} & \frac{1}{8} \\ \frac{1}{4} & \frac{1}{2} & \frac{1}{4} \\ \frac{1}{8} & -\frac{1}{4} & -\frac{3}{8} \end{bmatrix}$

(b)  $\begin{bmatrix} -\frac{5}{8} & \frac{1}{4} & -\frac{1}{8} \\ \frac{1}{4} & \frac{1}{2} & \frac{1}{4} \\ -\frac{1}{8} & \frac{1}{4} & \frac{3}{8} \end{bmatrix}$

(c)  $\begin{bmatrix} \frac{1}{4} & \frac{1}{2} & \frac{1}{4} \\ \frac{1}{8} & -\frac{1}{4} & -\frac{3}{8} \\ \frac{5}{8} & -\frac{1}{4} & \frac{1}{8} \end{bmatrix}$

(d)  $\begin{bmatrix} \frac{1}{4} & \frac{1}{2} & \frac{1}{4} \\ \frac{5}{8} & -\frac{1}{4} & \frac{1}{8} \\ \frac{1}{8} & -\frac{1}{4} & -\frac{3}{8} \end{bmatrix}$

29. Write the product as a sum:  $\sin 4x \sin x$ .  
 (a)  $\frac{1}{2}(\cos 5x + \cos 3x)$                       (b)  $\frac{1}{2}(\cos 3x - \cos 5x)$   
 (c)  $\frac{1}{2}(\sin 5x + \sin 3x)$                       (d)  $\frac{1}{2}(\sin 5x - \sin 3x)$

Problems 30–35 refer to the graph in Figure A.14.

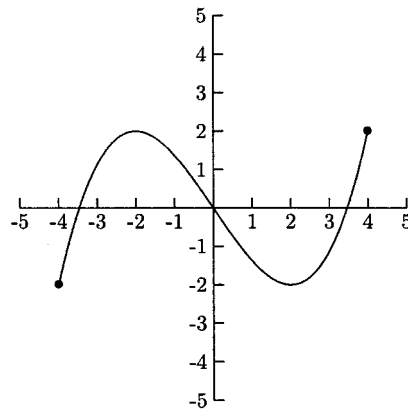

Fig. A.14.

30. Is the graph in Figure A.14 symmetric?  
 (a) Yes, with respect to the  $x$ -axis (b) Yes, with respect to the  $y$ -axis  
 (c) Yes, with respect to the origin (d) No
31. What is  $f(-4)$ ?  
 (a)  $-2$  (b)  $0$  (c)  $2$  (d)  $4$
32. What is the  $y$ -intercept?  
 (a)  $-2$  (b)  $0$  (c)  $2$  (d)  $4$
33. Does the function have an inverse?  
 (a) Yes (b) No  
 (c) Cannot be determined
34. What is the range?  
 (a)  $[-4, 4]$  (b)  $[-2, 2]$  (c)  $[-2, -4]$  (d)  $[2, 4]$
35. What is the increasing interval(s)?  
 (a)  $(-4, -2) \cup (2, 4)$  (b)  $(-4, 4)$   
 (c)  $(2, 2)$  (d)  $(-2, 2)$
36. Is the function  $f(x) = x^2 - x + 2$  even, odd, or neither?  
 (a) Even (b) Odd (c) Neither  
 (d) Cannot be determined without the graph
37. Are the points  $(-4, 2)$ ,  $(1, 3)$ ,  $(-1, 0)$ , and  $(-2, 5)$  the vertices of a parallelogram?  
 (a) Yes (b) No  
 (c) Cannot be determined

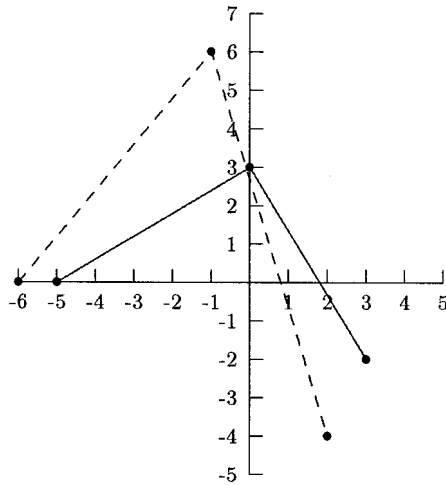

Fig. A.15.

38. The solid graph in Figure A.15 is the graph of  $f(x)$ , and the dashed graph is the graph of a transformation. What is the transformation?  
 (a)  $f(x + 1) + 3$  (b)  $f(x - 1) + 3$  (c)  $2f(x + 1)$  (d)  $2f(x - 1)$

39. Find the sum.

$$-6 + (-2) + 2 + 6 + 10 + \dots + 50$$

- (a) 660 (b) 260 (c) 330  
 (d) Too many terms are missing to find the sum.
40. What is  $x + y$  for the system? Use a matrix method.

$$\begin{cases} -x + 4y = 11 \\ 2x + 3y = 22 \end{cases}$$

- (a) 7 (b) 8 (c) 9 (d) 10
41. Are the angles  $65^\circ$  and  $-295^\circ$  coterminal?  
 (a) Yes (b) No (c) Cannot be determined
42. Find  $f^{-1}(x)$  for  $f(x) = \frac{x-3}{x+4}$ .

- (a)  $\frac{x+4}{x-3}$  (b)  $\frac{1}{x+4}$   
 (c)  $\frac{-4x-3}{x-1}$  (d)  $\frac{4x+3}{x-1}$

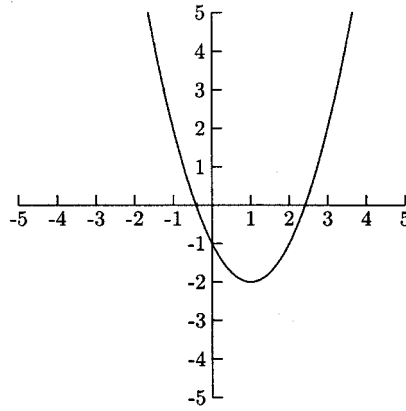

Fig. A.16.

43. The graph in Figure A.16 is the graph of what function?
- (a)  $f(x) = x^2 - 2x - 1$                       (b)  $f(x) = x^2 + 2x - 1$   
 (c)  $f(x) = x^2 - 3x - 1$                       (d)  $f(x) = x^2 + 3x - 1$
44. A biscuit recipe calls for  $\frac{2}{3}$  of a cup of milk for each cup of mix. Find an equation that gives the amount of milk in terms of the amount of mix.
- (a)  $y = \frac{3}{2}x$                                       (b)  $y = \frac{2}{3}x$   
 (c)  $y = \frac{5}{3}x$                                       (d) Cannot be determined
45. Rewrite  $m^r = n$  as a logarithmic equation.
- (a)  $\log_n r = m$                                 (b)  $\log_m r = n$   
 (c)  $\log_n m = r$                                 (d)  $\log_m n = r$
46. A museum offers group discounts for groups of 25 or more. For a group of 25, the ticket price is \$13.50. For each additional person attending, the price drops \$0.50. What group size maximizes the museum's revenue?
- (a) 26                      (b) 27                      (c) 28                      (d) 29
47. The graph in Figure A.17 is the graph of which function?
- (a)  $P(x) = (x + 3)(x - 1)^2(x + 1) = x^4 + 2x^3 - 4x^2 - 2x + 3$   
 (b)  $P(x) = -(x + 3)(x - 1)^2(x + 1) = -x^4 - 2x^3 + 4x^2 + 2x - 3$   
 (c)  $P(x) = (x + 3)(x - 1)(x + 1) = x^3 + 3x^2 - x - 3$   
 (d)  $P(x) = -(x + 3)(x - 1)(x + 1) = -x^3 - 3x^2 + x + 3$

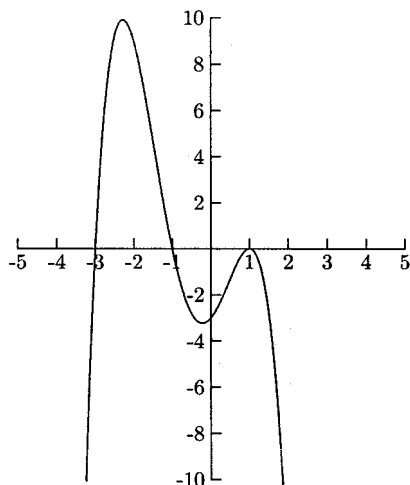

Fig. A.17.

48. What is the determinant for  $\begin{bmatrix} 1 & 1 & 0 \\ 1 & 0 & 1 \\ 3 & -2 & 1 \end{bmatrix}$ ?
- (a) 3                      (b) 4                      (c) 5                      (d) 6
49. Find the domain for  $f(x) = \frac{6}{x-8}$ .
- (a)  $(8, \infty)$                       (b)  $(-\infty, 8) \cup (8, \infty)$   
 (c)  $(-\infty, 8] \cup [8, \infty)$                       (d)  $[8, \infty)$
50. Are  $f(x) = 4x^3 + 1$  and  $g(x) = \sqrt[3]{\frac{x-1}{4}}$  inverses?
- (a) Yes                      (b) No  
 (c) Cannot be determined
51. Solve for  $x$ :  $\log_5(2x - 7) = 1$ .
- (a)  $x = 4$                       (b)  $x = 5$                       (c)  $x = 6$                       (d)  $x = 7$
52. The graph in Figure A.18 is the graph of which function?
- (a)  $f(x) = \frac{x}{x+1}$                       (b)  $f(x) = \frac{x^2}{x+1}$   
 (c)  $f(x) = \frac{x}{x-1}$                       (d)  $f(x) = \frac{x^2}{x-1}$

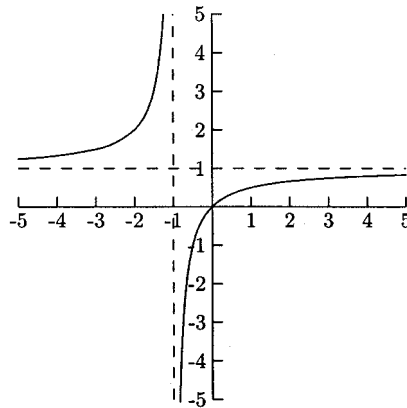

Fig. A.18.

53. According to the Rational Zero Theorem, which of the following is *NOT* a possible rational zero for  $f(x) = 6x^4 - x^3 - 3x^2 + x - 10$ ?
- (a)  $-\frac{1}{3}$       (b)  $-10$       (c)  $3$       (d)  $\frac{5}{6}$

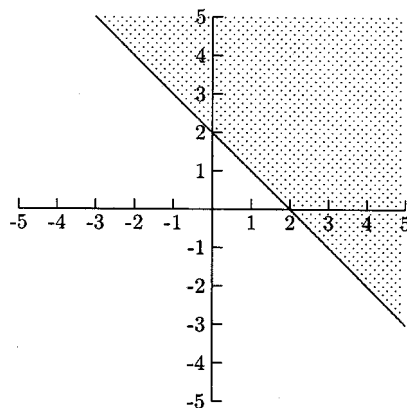

Fig. A.19.

54. The graph in Figure A.19 is the graph of which inequality?
- (a)  $x + y \geq 2$       (b)  $x + y > 2$       (c)  $x + y \leq 2$       (d)  $x + y < 2$
55. Find the quadratic function with vertex  $(-1, 3)$  with the point  $(2, -15)$  on its graph.
- (a)  $f(x) = -18(x - 1)^2 + 3$       (b)  $f(x) = 18(x - 1)^2 + 3$   
 (c)  $f(x) = -2(x + 1)^2 + 3$       (d)  $f(x) = 2(x + 1)^2 + 3$

56. Rewrite as a single logarithm:  $\ln x - 3 \ln y - \ln z$ .

(a)  $\ln \frac{x}{3yz}$

(b)  $\ln \frac{x}{y^3z}$

(c)  $\ln \frac{xz}{y^3}$

(d)  $\frac{\ln x}{3 \ln yz}$

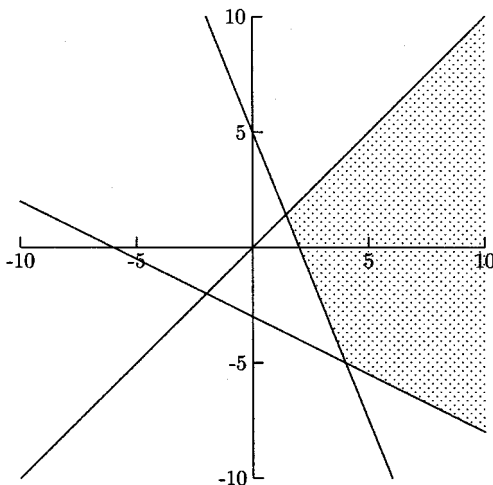

Fig. A.20.

57. The graph in Figure A.20 is the graph of which system?

(a) 
$$\begin{cases} y \leq x \\ y \leq -\frac{5}{2}x + 5 \\ y \leq -\frac{1}{2}x - 3 \end{cases}$$

(b) 
$$\begin{cases} y \leq x \\ y \geq -\frac{5}{2}x + 5 \\ y \leq -\frac{1}{2}x - 3 \end{cases}$$

(c) 
$$\begin{cases} y \geq x \\ y \leq -\frac{5}{2}x + 5 \\ y \leq -\frac{1}{2}x - 3 \end{cases}$$

(d) 
$$\begin{cases} y \leq x \\ y \geq -\frac{5}{2}x + 5 \\ y \geq -\frac{1}{2}x - 3 \end{cases}$$

58. The graph in Figure A.21 is the graph of which equation?

(a)  $x^2 - \frac{y^2}{4} = 1$

(b)  $\frac{x^2}{4} - y^2 = 1$

(c)  $x^2 + \frac{y^2}{4} = 1$

(d)  $\frac{x^2}{4} + y^2 = 1$



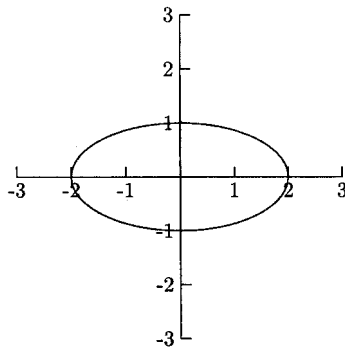

Fig. A.21.

59. What is  $x + y + z$  for the system? Use a matrix method.

$$\begin{cases} x + y & = 11 \\ x & + z = -1 \\ 3x - 2y + z & = -11 \end{cases}$$

- (a) 6      (b) 7      (c) 8      (d) 9

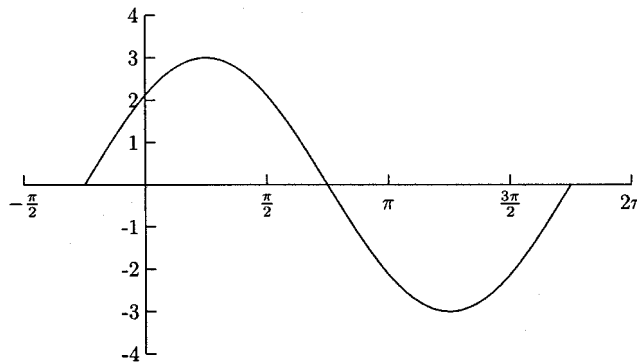

Fig. A.22.

60. The graph in Figure A.22 is the graph of one period of which function?

- (a)  $y = 3 \sin(x - \pi/4)$       (b)  $y = 3 \sin(x + \pi/4)$   
 (c)  $y = \sin 3(x - \pi/4)$       (d)  $y = \sin 3(x + \pi/4)$

61. Evaluate  $\frac{f(a+h)-f(a)}{h}$  for  $f(x) = 2x^2 - 1$ .

- (a)  $4a + 2h^2 - 2$       (b)  $4a + 2h^2 - 1$       (c)  $4a + 2h$       (d)  $4a + 2h^2$

62. According to Descartes' Rule of Signs, how many possible positive zeros are there for  $f(x) = 6x^4 - x^3 - 3x^2 + x - 10$ ?
- (a) 3 or 1      (b) 3      (c) 2 or 0      (d) 2

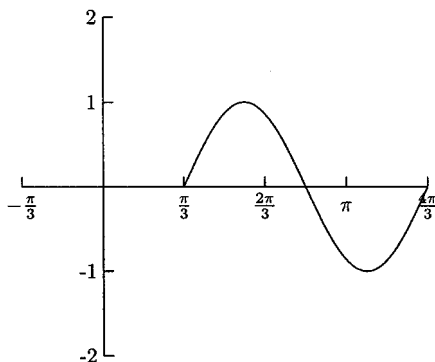

Fig. A.23.

63. The graph in Figure A.23 is the graph of one period of which function?
- (a)  $y = 2 \sin(x - \pi/3)$       (b)  $y = 2 \sin(x + \pi/3)$   
 (c)  $y = \sin 2(x - \pi/3)$       (d)  $y = \sin 2(x + \pi/3)$
64. The graph of  $3f(x - 4)$  is the graph of  $f(x)$
- (a) shifted to the right four units and vertically stretched.  
 (b) shifted to the left four units and vertically stretched.  
 (c) shifted to the right four units and vertically compressed.  
 (d) shifted to the left four units and vertically compressed.

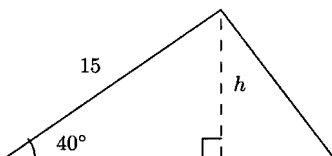

Fig. A.24.

65. Find the height of the triangle in Figure A.24.
- (a) About 11.5      (b) About 0.04      (c) About 9.6      (d) About 0.05
66. Find all zeros for  $f(x) = 3x^3 - 7x^2 + 8x - 2$ .
- (a)  $-\frac{1}{3}, 1 \pm i$       (b)  $\frac{1}{3}, 1 \pm i$       (c)  $-\frac{1}{3}, -1 \pm i$       (d)  $-\frac{1}{3}, -1 \pm i$

67. What are the intercepts for  $f(x) = -x^2 + x + 2$ ?
- (a) The  $x$ -intercepts are 1 and 2, and the  $y$ -intercept is 2.
  - (b) The  $x$ -intercepts are  $-1$  and 2, and the  $y$ -intercept is 2.
  - (c) The  $x$ -intercepts are 1 and  $-2$ , and the  $y$ -intercept is  $-2$ .
  - (d) The  $x$ -intercepts are  $-1$  and 2, and the  $y$ -intercept is  $-2$ .

68.  $\cos(\tan^{-1} 1/5) =$

- (a)  $\frac{5\sqrt{26}}{26}$       (b)  $\frac{\sqrt{26}}{5}$       (c)  $\frac{\sqrt{26}}{26}$       (d)  $\sqrt{26}$

69. What is the slant asymptote for the graph of

$$f(x) = \frac{x^2 - 9}{x + 2}?$$

- (a)  $y = x - 11$     (b)  $y = x + 2$     (c)  $y = x - 7$     (d)  $y = x - 2$
70. The population of a town grew from 2000 in the year 1980 to 10,000 in the year 2000. Assuming exponential growth, what is the town's annual growth rate?
- (a) About 6%    (b) About 7%    (c) About 8%    (d) About 9%

71. What is the quotient for  $\frac{4+5i}{2-i}$ ?

- (a)  $\frac{13}{3} + 2i$     (b)  $\frac{3}{5} + \frac{14}{5}i$     (c)  $\frac{13}{5} - \frac{6}{5}i$     (d)  $\frac{13}{5} + \frac{6}{5}i$

72. What is the quotient for  $(2x^3 - x^2 + 2) \div (x + 3)$ ?

- (a)  $2x^2 - 7x - 21$       (b)  $2x^2 + 5x + 15$   
(c)  $2x^2 - 7x + 23$       (d)  $2x^2 - 7x + 21$

73. What are the vertices for the ellipse

$$\frac{x^2}{25} + \frac{y^2}{16} = 1?$$

- (a)  $(-4, 0)$  and  $(4, 0)$       (b)  $(0, -4)$  and  $(0, 4)$   
(c)  $(-5, 0)$  and  $(5, 0)$       (d)  $(0, 5)$  and  $(0, -5)$
74. A triangle has sides of length 8, 15, and 20. Which of the following is an approximate angle in this triangle?
- (a)  $48.3^\circ$     (b)  $41.7^\circ$     (c)  $50.6^\circ$     (d)  $23.6^\circ$

# Final Exam



75. Which one of the following statements is NOT true about the polynomial function  $f(x) = x^3(x - 4)^2(x + 1)$ ?
- (a)  $x = 0$  is a zero of multiplicity 3.
  - (b)  $x = 4$  is a zero of multiplicity 2.
  - (c)  $x = 1$  is a zero of multiplicity 1.
  - (d)  $x = -1$  is a zero of multiplicity 1.

## SOLUTIONS

- |       |       |       |       |       |       |       |       |
|-------|-------|-------|-------|-------|-------|-------|-------|
| 1. A  | 2. C  | 3. A  | 4. B  | 5. D  | 6. A  | 7. A  | 8. B  |
| 9. A  | 10. C | 11. B | 12. A | 13. C | 14. C | 15. D | 16. D |
| 17. A | 18. B | 19. A | 20. D | 21. C | 22. D | 23. A | 24. C |
| 25. B | 26. B | 27. A | 28. D | 29. B | 30. C | 31. A | 32. B |
| 33. B | 34. B | 35. A | 36. C | 37. A | 38. C | 39. C | 40. C |
| 41. A | 42. C | 43. A | 44. B | 45. D | 46. A | 47. B | 48. B |
| 49. B | 50. A | 51. C | 52. A | 53. C | 54. A | 55. C | 56. B |
| 57. D | 58. D | 59. B | 60. B | 61. C | 62. A | 63. C | 64. A |
| 65. C | 66. B | 67. B | 68. A | 69. D | 70. C | 71. B | 72. D |
| 73. C | 74. B | 75. C |       |       |       |       |       |

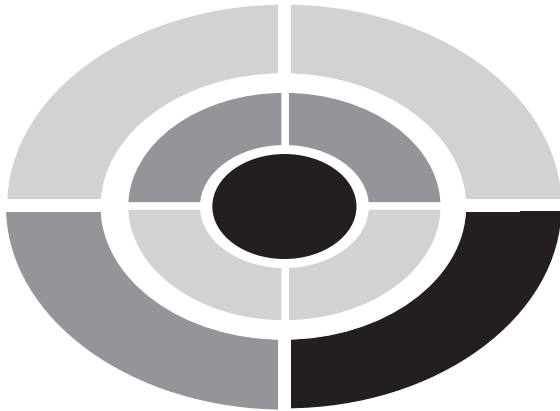

# INDEX

- Absolute value function
  - graph of, 89, 90, 93, 94
- Angles (*see also* Solving triangles)
  - coterminal, 366
  - degrees, 364, 365
  - initial side of, 364, 365
  - radians, 364, 365
  - reference, 367, 368–369
  - terminal side of, 364, 365
- Arithmetic sequences, 421–425
  - partial sums of, 423–425
- Asymptotes
  - and hyperbolas, 347, 348, 349
  - horizontal, 186–189
  - slant, 193–195
  - and trigonometric functions, 382, 383, 385
  - vertical, 185, 186–187, 190–192
- Average rate of change, 50–52
- Base
  - of exponents, 214
  - of logarithms, 214
- Change of base formula, 240–241
- Circle, 344
- Coefficient
  - leading, 134
  - matrix, 315, 318
  - of polynomial terms, 134
- Combinations of functions
  - arithmetic, 64–65
  - composition, 65–71
- Common logarithm, 217
- Completing the square, 109–111, 359–360
- Complex numbers
  - arithmetic, 166–169
  - as solutions to quadratic equations, 172–173
  - as zeros of a polynomial, 165, 175–177, 178
- Compound growth/decay, 205, 246–247, 249–250, 251–253, 254–255, 257–258
- Compound interest, 201–204
- Conics (*see* Ellipse, Hyperbola, Parabola)
- Constant
  - function, 25
  - term, 134
- Cosecant, 372–374
  - graph of, 382–384
- Cosine
  - graph of, 375, 377–379
  - inverse of, 392–394
  - and right triangles, 386–388, 395–397
  - and the unit circle, 369–374
- Cotangent, 372–374
  - graph of, 385
- Cubic function
  - graph of, 89, 91, 92
- Descartes' Rule of Signs, 160–161
- Determinant, 324–327
- Difference quotient (*see* Newton's Quotient)
- Directrix
  - of a parabola, 330, 331, 332
- Discriminant, 173
- Division of polynomials
  - long, 144–148
  - synthetic, 148–150

- Domain
- of a function, 34–37, 39–40
  - in function composition, 69–70
  - from a graph, 43–45
  - of logarithm functions, 228
  - of trigonometric functions, 375, 382, 385, 392, 393, 394
- Elimination by addition, 265–268, 279–280
- Ellipse, 338–345
- End behavior of polynomials, 135–137
- Equations
- of conic sections, 331, 332, 338, 339, 343–344, 348, 349, 352–354, 357–360,
  - exponential, 223, 241, 243–244
  - of lines, 4–11
  - of logarithms, 220–221, 229–230, 237–238
  - of polynomials, 134
  - of quadratic functions, 104–111
  - of rational functions, 185
  - solving, 439–444
  - systems of, 262–281, 315–320
  - of trigonometric functions, 374–375, 382–383
- Even functions, 58–59
- Exponent
- functions, 209
  - properties, 210, 231, 232
- Factoring by grouping, 442–443
- Focus
- in an ellipse, 338, 339
  - in a hyperbola, 347, 348, 349
  - in a parabola, 330, 331, 332
- Functions
- composition of, 65–71
  - definition of, 24
  - domain, 34–37, 39–40, 43–45
  - evaluating, 25–27, 28–29
  - even and odd, 55–59
  - exponential, 209
  - increasing and decreasing intervals, 45–47
  - logarithmic, 225, 228
  - quadratic, 104–133
  - range, 34, 43–45
  - rational, 185–200
  - trigonometric, 374–375, 382–383
- Fundamental Theorem of Algebra, 175
- Geometric sequences, 426–432
- partial sums of, 429–431
  - sums of, 431–432
- Graphs
- and domain and range, 43–45
  - of ellipses, 338–340, 342–343
  - of exponential functions, 209–211, 214
  - of functions, 42–61
  - and function composition, 68–69
  - of hyperbolas, 348–352
  - of inequalities, 284–289
  - intercepts of, 43, 105–108, 185, 187
  - of inverse functions, 77–79
  - of lines, 2–5, 7–10
  - of logarithmic functions, 225–226
  - of one-to-one functions, 79–80
  - of parabolas, 104–108, 330–333
  - of polynomial functions, 134–140
  - of quadratic functions, 104–108
  - of rational functions, 190–195
  - symmetry of, 55–58
  - of systems of equations, 263, 265, 266, 278, 279
  - of systems of inequalities, 289–296
  - transformations of, 89–97
  - of trigonometric functions, 374–379, 382–385, 393
- Half-life (*see* Radioactive decay)
- Horizontal
- asymptotes, 186–189
  - lines, 4
  - line test, 79–80
  - transformations, 89–97
- Hyperbola 347–354
- Imaginary numbers (*see* Complex numbers)
- Identity function, 75
- Inequalities
- graphs of, 284–289
  - nonlinear, 445–449
  - solving, 444–449
  - systems of, 289–296
- Intercepts, 43, 105–108, 185, 187
- as zeros of a polynomial, 137–139

- Interval
  - increasing/decreasing, 45–47
  - notation of, 449
- Inverse
  - functions, 75–82
  - of a matrix, 307–313, 318–320
  - of trigonometric functions, 392–397, 401, 402
  
- Law of Cosines, 398, 400–402
- Law of Sines, 398, 400–402
- Lines
  - equations of, 4–11
  - graphs of, 2–5, 7–10
  - horizontal, 4
  - parallel, 9, 10–11
  - perpendicular, 9–11
  - slope of, 1–4
  - vertical, 4–5
- Logarithms, 214–258
  - applications of, 246–247, 249–250, 251–253
  - base of, 214
  - equations, 220–221, 229–230, 237–238
  - functions, 225, 228
  - properties, 231–232, 234–235
  
- Matrix
  - arithmetic, 304–306
  - determinant of, 324–327
  - identity, 305
  - inverse of, 307–313, 318–320
  - row operations, 307–313, 316–320
  - and solving systems of equations, 315–320
- Multiplicity of zeros, 177, 178
  
- Natural logarithm, 217
- Newton's Quotient, 30–32
- Nonlinear inequalities
  - graphs of, 288–289, 290–291, 294–296
  - solving, 445–449
  
- Odd functions, 58–59
- One-to-one functions, 79–80
  
- Parabola, 104–108, 330–336
- Partial sums, 418–419, 423–425, 429–431
- Polynomials, 134–184
  - degree, 134
  - dividing, 144–150
  - factoring, 151–153, 157–160
  - graphs of, 134–140
  - zeros of, 137, 152–153, 157–159, 172–179
- Present value, 205–206, 436
  
- Quadrant, 367–369, 372
- Quadratic equation
  - complex solutions to, 172–173
  - solving, 440–442
- Quadratic formula, 441
- Quadratic functions, 104–133
  
- Radioactive decay, 254–255, 257–258
- Range, 34, 44–45
- Rational functions,
  - asymptotes of, 185–195
  - graphs of, 190–195
- Rational Zero Theorem, 156–157
- Remainder Theorem, 151
- Right triangles, 14–15
  - and trigonometric ratios, 386–391, 394–398
  
- Secant, 372–374
  - graph of, 382
- Sequence
  - arithmetic, 421–425
  - geometric, 426–432
  - partial sum of, 418–419, 423–425, 429–431
  - recursively defined, 416
  - terms of, 415–416, 421, 427
- Series, 415, 431–432
- Sine
  - graph of, 374–377, 379
  - inverse of, 392–394
  - and right triangles, 386–388, 395–398
  - and the unit circle, 369–374
- Slant asymptotes
  - and hyperbolas, 347, 348, 349
  - and rational functions, 193–195

- Slope  
and the average rate of change, 51, 52  
formula, 1–4  
of horizontal lines, 3  
interpreting, 1–3, 17–18  
and Newton's Quotient, 32  
of parallel and perpendicular lines, 9–11  
of vertical lines, 4
- Square root function, graph of, 89, 90, 92, 93
- Substitution method, 263–265, 280–281
- Symmetry  
axis of, 331  
of graphs, 55–58
- Synthetic division, 148–150
- Systems of equations, 262–281, 315–320
- Systems of inequalities, 289–296
- Tangent, 372–374  
graph of, 385  
inverse of, 392–394  
and right triangles, 386–388, 395–397
- Transformations and translations, 89–97
- Triangles, 386–391, 394–398, 399–402  
and the Law of Cosines, 398, 400, 402  
and the Law of Sines, 398, 400–402
- Trigonometric functions (*see also* Cosine, Sine, and Tangent)  
co-functions of, 387–388  
even, odd properties, 375, 383
- Unit circle, 364–374  
angles on, 364–369  
terminal points on, 369, 371–374  
trigonometric functions and, 369–374
- Upper and lower Bounds Theorem, 160, 161–162
- Vertical asymptotes  
and rational functions, 185, 186–187, 190–192  
and trigonometric functions, 382, 383, 385
- Vertical line test, 43–44
- Vertical lines, 4, 5
- Vertical transformations, 89–97
- Vertices  
of ellipses, 338, 339  
of hyperbolas, 347, 348, 349  
of parabolas, 104, 108–112, 331, 332
- Zeros of a polynomial, 137, 152–153, 157–159, 172–179





## ABOUT THE AUTHOR

**Rhonda Huettenmueller** is the author of the best-selling book in the *Demystified* series, *Algebra Demystified*. Popular with students for her ability to make higher math understandable and even enjoyable, she incorporates many of her teaching techniques in this book. Ms. Huettenmueller has taught mathematics at the college level for almost 15 years. She received her Ph.D. in mathematics from the University of North Texas.