

IBM System x3455 Type 7984 and 7986



Problem Determination and Service Guide

IBM System x3455 Type 7984 and 7986



Problem Determination and Service Guide

Note: Before using this information and the product it supports, read the general information in Appendix B, "Notices," on page 115 and the *Warranty and Support Information* document on the IBM System x *Documentation* CD.

First Edition (September 2006)

© Copyright International Business Machines Corporation 2006. All rights reserved.

US Government Users Restricted Rights – Use, duplication or disclosure restricted by GSA ADP Schedule Contract with IBM Corp.

Contents

Safety	vii
Guidelines for trained service technicians	viii
Inspecting for unsafe conditions	viii
Guidelines for servicing electrical equipment	viii
Safety statements	x
Chapter 1. Introduction	1
Related documentation	1
Notices and statements in this document	2
Features and specifications	3
Server controls, LEDs, and connectors	5
Front view	5
Rear view	6
Internal LEDs, connectors, and jumpers	7
System-board internal and option connectors	7
Operator information panel controls and internal connectors	8
System-board switches and jumpers	9
System-board external connectors	11
System-board LEDs	12
Chapter 2. Diagnostics	15
Diagnostic tools	15
POST	15
POST beep codes	15
Error logs	20
POST error codes	21
Checkout procedure	28
About the checkout procedure	28
Performing the checkout procedure	28
Troubleshooting tables	30
CD or DVD drive problems	30
General problems	31
Hard disk drive problems	32
Intermittent problems	32
USB keyboard, mouse, or pointing-device problems	33
Memory problems	34
Microprocessor problems	35
Monitor or video problems	36
Optional-device problems	38
Power problems	39
Serial port problems	40
ServerGuide problems	40
Software problems	41
Universal Serial Bus (USB) device problems	41
System board error LEDs and the light path button	42
Light path button	43
Power-supply LEDs	43
Diagnostic programs, messages, and error codes	45
Running the diagnostic programs	45
Diagnostic text messages	46
Viewing the test log	46
Diagnostic error codes	47
Recovering from a BIOS update failure	51

BMC system-event log messages	53
Erasing a lost or forgotten password (clearing CMOS)	57
Solving power problems	58
Solving Ethernet controller problems	59
Solving undetermined problems	60
Calling IBM for service	60
Chapter 3. Parts listing, Type 7984 and 7986 servers.	63
Replaceable server components	65
Power cords	66
Chapter 4. Removing and replacing server components	69
Installation guidelines	69
System reliability guidelines	70
Handling static-sensitive devices	70
Returning a device or component	70
Removing and replacing Tier 1 CRUs	71
Removing the cover	71
Installing the cover	71
Removing an air baffle	72
Installing an air baffle	73
Removing a riser-card assembly	74
Installing a riser-card assembly	75
Removing an adapter	76
Installing an adapter	77
Removing the CD or DVD drive	77
Installing the CD or DVD drive	79
Removing a memory module (DIMM)	80
Installing a memory module	81
Removing a fan	83
Installing a fan	84
Removing the system-board battery	84
Installing the system-board battery	85
Removing the power supply	87
Installing the power supply	89
Removing and replacing Tier 2 CRUs	90
Removing the operator information panel	90
Installing the operator information panel	91
Removing the CD or DVD backplane	92
Installing the CD or DVD backplane	93
Removing the front hard disk drive cage assembly	94
Installing the front hard disk drive cage assembly	95
Removing the rear hard disk drive cage assembly	96
Installing the rear hard disk drive cage assembly	97
Removing the front hard disk drive	97
Installing the front hard disk drive	98
Removing the rear hard disk drive	99
Installing the rear hard disk drive	100
Removing and replacing FRUs	102
Removing a microprocessor	102
Installing a microprocessor	103
Removing the system board	105
Installing the system board	106
Chapter 5. Configuration information and instructions	109
Updating the firmware	109

Configuring the server	109
Using the Configuration/Setup Utility program	109
Configuring the Ethernet controller	110
Updating the BMC firmware	110
Updating the UUID	111
Updating the DMI/SMBIOS data	111
Appendix A. Getting help and technical assistance	113
Before you call	113
Using the documentation	113
Getting help and information from the World Wide Web	114
Software service and support	114
Hardware service and support	114
Appendix B. Notices	115
Trademarks	115
Important notes	116
Product recycling and disposal	117
Battery return program	118
Electronic emission notices	119
Federal Communications Commission (FCC) statement	119
Industry Canada Class A emission compliance statement	119
Australia and New Zealand Class A statement	119
United Kingdom telecommunications safety requirement	119
European Union EMC Directive conformance statement	119
Taiwanese Class A warning statement	120
Chinese Class A warning statement	120
Japanese Voluntary Control Council for Interference (VCCI) statement	120
Index	121

Safety

Before installing this product, read the Safety Information.

قبل تركيب هذا المنتج، يجب قراءة الملاحظات الأمنية

Antes de instalar este produto, leia as Informações de Segurança.

在安装本产品之前，请仔细阅读 **Safety Information** (安全信息)。

安裝本產品之前，請先閱讀「安全資訊」。

Prije instalacije ovog produkta obavezno pročitajte Sigurnosne Upute.

Před instalací tohoto produktu si přečtěte příručku bezpečnostních instrukcí.

Læs sikkerhedsforskrifterne, før du installerer dette produkt.

Lees voordat u dit product installeert eerst de veiligheidsvoorschriften.

Ennen kuin asennat tämän tuotteen, lue turvaohjeet kohdasta Safety Information.

Avant d'installer ce produit, lisez les consignes de sécurité.

Vor der Installation dieses Produkts die Sicherheitshinweise lesen.

Πριν εγκαταστήσετε το προϊόν αυτό, διαβάστε τις πληροφορίες ασφαλείας (safety information).

לפני שתתקינו מוצר זה, קראו את הוראות הבטיחות.

A termék telepítése előtt olvassa el a Biztonsági előírásokat!

Prima di installare questo prodotto, leggere le Informazioni sulla Sicurezza.

製品の設置の前に、安全情報をお読みください。

본 제품을 설치하기 전에 안전 정보를 읽으십시오.

Пред да се инсталира овој продукт, прочитајте информацијата за безбедност.

Les sikkerhetsinformasjonen (Safety Information) før du installerer dette produktet.

Przed zainstalowaniem tego produktu, należy zapoznać się z książką "Informacje dotyczące bezpieczeństwa" (Safety Information).

Antes de instalar este produto, leia as Informações sobre Segurança.

Перед установкой продукта прочтите инструкции по технике безопасности.

Pred inštaláciou tohto zariadenia si pečítajte Bezpečnostné predpisy.

Pred namestitvijo tega proizvoda preberite Varnostne informacije.

Antes de instalar este producto, lea la información de seguridad.

Läs säkerhetsinformationen innan du installerar den här produkten.

Guidelines for trained service technicians

This section contains information for trained service technicians.

Inspecting for unsafe conditions

Use the information in this section to help you identify potential unsafe conditions in an IBM product that you are working on. Each IBM product, as it was designed and manufactured, has required safety items to protect users and service technicians from injury. The information in this section addresses only those items. Use good judgment to identify potential unsafe conditions that might be caused by non-IBM alterations or attachment of non-IBM features or optional devices that are not addressed in this section. If you identify an unsafe condition, you must determine how serious the hazard is and whether you must correct the problem before you work on the product.

Consider the following conditions and the safety hazards that they present:

- Electrical hazards, especially primary power. Primary voltage on the frame can cause serious or fatal electrical shock.
- Explosive hazards, such as a damaged CRT face or a bulging capacitor.
- Mechanical hazards, such as loose or missing hardware.

To inspect the product for potential unsafe conditions, complete the following steps:

1. Make sure that the power is off and the power cord is disconnected.
2. Make sure that the exterior cover is not damaged, loose, or broken, and observe any sharp edges.
3. Check the power cord:
 - Make sure that the third-wire ground connector is in good condition. Use a meter to measure third-wire ground continuity for 0.1 ohm or less between the external ground pin and the frame ground.
 - Make sure that the power cord is the correct type, as specified in "Power cords" on page 66.
 - Make sure that the insulation is not frayed or worn.
4. Remove the cover.
5. Check for any obvious non-IBM alterations. Use good judgment as to the safety of any non-IBM alterations.
6. Check inside the server for any obvious unsafe conditions, such as metal filings, contamination, water or other liquid, or signs of fire or smoke damage.
7. Check for worn, frayed, or pinched cables.
8. Make sure that the power-supply cover fasteners (screws or rivets) have not been removed or tampered with.

Guidelines for servicing electrical equipment

Observe the following guidelines when you service electrical equipment:

- Check the area for electrical hazards such as moist floors, nongrounded power extension cords, power surges, and missing safety grounds.
- Use only approved tools and test equipment. Some hand tools have handles that are covered with a soft material that does not provide insulation from live electrical currents.
- Regularly inspect and maintain your electrical hand tools for safe operational condition. Do not use worn or broken tools or testers.

- Do not touch the reflective surface of a dental mirror to a live electrical circuit. The surface is conductive and can cause personal injury or equipment damage if it touches a live electrical circuit.
- Some rubber floor mats contain small conductive fibers to decrease electrostatic discharge. Do not use this type of mat to protect yourself from electrical shock.
- Do not work alone under hazardous conditions or near equipment that has hazardous voltages.
- Locate the emergency power-off (EPO) switch, disconnecting switch, or electrical outlet so that you can turn off the power quickly in the event of an electrical accident.
- Disconnect all power before you perform a mechanical inspection, work near power supplies, or remove or install main units.
- Before you work on the equipment, disconnect the power cord. If you cannot disconnect the power cord, have the customer power-off the wall box that supplies power to the equipment and lock the wall box in the off position.
- Never assume that power has been disconnected from a circuit. Check it to make sure that it has been disconnected.
- If you have to work on equipment that has exposed electrical circuits, observe the following precautions:
 - Make sure that another person who is familiar with the power-off controls is near you and is available to turn off the power if necessary.
 - When you work with powered-on electrical equipment, use only one hand. Keep the other hand in your pocket or behind your back to avoid creating a complete circuit that could cause an electrical shock.
 - When you use a tester, set the controls correctly and use the approved probe leads and accessories for that tester.
 - Stand on a suitable rubber mat to insulate you from grounds such as metal floor strips and equipment frames.
- Use extreme care when you measure high voltages.
- To ensure proper grounding of components such as power supplies, pumps, blowers, fans, and motor generators, do not service these components outside of their normal operating locations.
- If an electrical accident occurs, use caution, turn off the power, and send another person to get medical aid.

Safety statements

Important:

Each caution and danger statement in this documentation begins with a number. This number is used to cross reference an English-language caution or danger statement with translated versions of the caution or danger statement in the *Safety Information* document.

For example, if a caution statement begins with a number 1, translations for that caution statement appear in the *Safety Information* document under statement 1.

Be sure to read all caution and danger statements in this documentation before performing the instructions. Read any additional safety information that comes with your server or optional device before you install the device.

Statement 1:



DANGER

Electrical current from power, telephone, and communication cables is hazardous.

To avoid a shock hazard:

- **Do not connect or disconnect any cables or perform installation, maintenance, or reconfiguration of this product during an electrical storm.**
- **Connect all power cords to a properly wired and grounded electrical outlet.**
- **Connect to properly wired outlets any equipment that will be attached to this product.**
- **When possible, use one hand only to connect or disconnect signal cables.**
- **Never turn on any equipment when there is evidence of fire, water, or structural damage.**
- **Disconnect the attached power cords, telecommunications systems, networks, and modems before you open the device covers, unless instructed otherwise in the installation and configuration procedures.**
- **Connect and disconnect cables as described in the following table when installing, moving, or opening covers on this product or attached devices.**

To Connect:

1. Turn everything OFF.
2. First, attach all cables to devices.
3. Attach signal cables to connectors.
4. Attach power cords to outlet.
5. Turn device ON.

To Disconnect:

1. Turn everything OFF.
2. First, remove power cords from outlet.
3. Remove signal cables from connectors.
4. Remove all cables from devices.

Statement 2:



CAUTION:

When replacing the lithium battery, use only IBM Part Number 33F8354 or an equivalent type battery recommended by the manufacturer. If your system has a module containing a lithium battery, replace it only with the same module type made by the same manufacturer. The battery contains lithium and can explode if not properly used, handled, or disposed of.

Do not:

- **Throw or immerse into water**
- **Heat to more than 100°C (212°F)**
- **Repair or disassemble**

Dispose of the battery as required by local ordinances or regulations.

Statement 3:



CAUTION:

When laser products (such as CD-ROMs, DVD drives, fiber optic devices, or transmitters) are installed, note the following:

- Do not remove the covers. Removing the covers of the laser product could result in exposure to hazardous laser radiation. There are no serviceable parts inside the device.
- Use of controls or adjustments or performance of procedures other than those specified herein might result in hazardous radiation exposure.



DANGER

Some laser products contain an embedded Class 3A or Class 3B laser diode. Note the following.

Laser radiation when open. Do not stare into the beam, do not view directly with optical instruments, and avoid direct exposure to the beam.



Class 1 Laser Product
Laser Klasse 1
Laser Klass 1
Luokan 1 Laserlaite
Appareil À Laser de Classe 1

Statement 4:

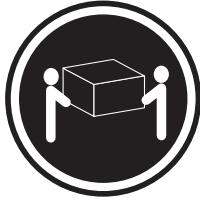

≥ 18 kg (39.7 lb)



≥ 32 kg (70.5 lb)

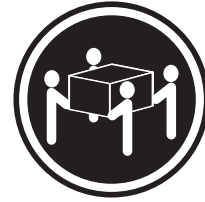

≥ 55 kg (121.2 lb)

CAUTION:

Use safe practices when lifting.

Statement 5:



CAUTION:

The power control button on the device and the power switch on the power supply do not turn off the electrical current supplied to the device. The device also might have more than one power cord. To remove all electrical current from the device, ensure that all power cords are disconnected from the power source.

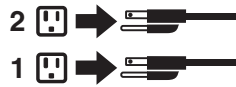

Statement 8:



CAUTION:

Never remove the cover on a power supply or any part that has the following label attached.



Hazardous voltage, current, and energy levels are present inside any component that has this label attached. There are no serviceable parts inside these components. If you suspect a problem with one of these parts, contact a service technician.

Statement 26:



CAUTION:

Do not place any object on top of rack-mounted devices.



Attention: This server is suitable for use on an IT power distribution system, whose maximum phase to phase voltage is 240 V under any distribution fault condition.

Chapter 1. Introduction

This *Problem Determination and Service Guide* contains information to help you solve problems that might occur in your IBM® System x3455 Type 7984 or 7986 server. It describes the diagnostic tools that come with the server, error codes and suggested actions, and instructions for replacing failing components.

Technical updates might be available to provide additional information that is not included in the server documentation. To check for updates, go to <http://www.ibm.com/servers/eserver/support/xseries/index.html>, select **System x3455** from the **Hardware** list, and click **Go**. For firmware updates, click the **Download** tab. For documentation updates, click the **Install and use** tab, and click **Product documentation**.

Replaceable components are of three types:

- **Tier 1 customer replaceable unit (CRU):** Replacement of Tier 1 CRUs is your responsibility. If IBM installs a Tier 1 CRU at your request, you will be charged for the installation.
- **Tier 2 customer replaceable unit:** You may install a Tier 2 CRU yourself or request IBM to install it, at no additional charge, under the type of warranty service that is designated for your server.
- **Field replaceable unit (FRU):** FRUs must be installed only by trained service technicians.

For information about the terms of the warranty and getting service and assistance, see the *Warranty and Support Information* document.

Related documentation

In addition to this document, the following documentation also comes with the server:

- *Installation Guide*

This printed document contains instructions for setting up the server and basic instructions for installing some optional devices.

- *User's Guide*

This document is in Portable Document Format (PDF) on the IBM *System x Documentation* CD. It provides general information about the server, including information about features, and how to configure the server. It also contains detailed instructions for installing, removing, and connecting optional devices that the server supports.

- *Rack Installation Instructions*

This printed document contains instructions for installing the server in a rack.

- *Safety Information*

This document is in PDF on the IBM *System x Documentation* CD. It contains translated caution and danger statements. Each caution and danger statement that appears in the documentation has a number that you can use to locate the corresponding statement in your language in the *Safety Information* document.

- *Warranty and Support Information*

This document is in PDF on the IBM *System x Documentation* CD. It contains information about the terms of the warranty and getting service and assistance.

Depending on the server model, additional documentation might be included on the *IBM System x Documentation CD*.

The System x and xSeries Tools Center is an online information center that contains information about tools for updating, managing, and deploying firmware, device drivers, and operating systems. The System x and xSeries Tools Center is at <http://publib.boulder.ibm.com/infocenter/toolsctr/v1r0/index.jsp>.

The server might have features that are not described in the documentation that comes with the server. The documentation might be updated occasionally to include information about those features, or technical updates might be available to provide additional information that is not included in the server documentation. These updates are available from the IBM Web site. To check for updated documentation and technical updates, complete the following steps.

Note: Changes are made periodically to the IBM Web site. The actual procedure might vary slightly from what is described in this document.

1. Go to <http://www.ibm.com/servers/eserver/support/xseries/index.html>
2. From the **Hardware** list, select **System x3455** and click **Go**.
3. Click the **Install and use** tab.
4. Click **Product documentation**.

Notices and statements in this document

The caution and danger statements that appear in this document are also in the multilingual *Safety Information* document, which is on the *IBM System x Documentation CD*. Each statement is numbered for reference to the corresponding statement in the *Safety Information* document.

The following notices and statements are used in this document:

- **Note:** These notices provide important tips, guidance, or advice.
- **Important:** These notices provide information or advice that might help you avoid inconvenient or problem situations.
- **Attention:** These notices indicate potential damage to programs, devices, or data. An attention notice is placed just before the instruction or situation in which damage could occur.
- **Caution:** These statements indicate situations that can be potentially hazardous to you. A caution statement is placed just before the description of a potentially hazardous procedure step or situation.
- **Danger:** These statements indicate situations that can be potentially lethal or extremely hazardous to you. A danger statement is placed just before the description of a potentially lethal or extremely hazardous procedure step or situation.

Features and specifications

The following information is a summary of the features and specifications of the server. Depending on the server model, some features might not be available, or some specifications might not apply.

Table 1. Features and specifications

<p>Microprocessors:</p> <ul style="list-style-type: none"> • Up to two dual-core AMD Opteron™ processors (one standard on all models) • 1 MB Level-2 cache per core <p>Note: Use the Configuration/Setup Utility program to determine the speed of the microprocessors.</p> <p>Memory:</p> <ul style="list-style-type: none"> • Minimum: 1024 MB • Maximum: 48 GB • Type: PC2-5300 error-correcting code (ECC), double-data-rate 2 (DDR2) SDRAM, registered DIMMs with Chipkill™ memory protection • Sizes: 512 MB, 1 GB, 2 GB, or 4 GB DIMMs in pairs <p>Note: Chipkill memory protection is not supported on 512 MB DIMMs.</p> <ul style="list-style-type: none"> • Six interleaved slots with standard microprocessor • Six additional interleaved slots with optional microprocessor • Standard: One pair of matching DIMMs 	<p>Drives:</p> <ul style="list-style-type: none"> • CD-RW/DVD: Ultrabay Enhanced IDE (standard only on some models) • Non-hot-swap hard disk drives: <ul style="list-style-type: none"> – One standard – Slim-high 3.5-inch drives – Serial Advanced Technology Attachment (SATA) <ul style="list-style-type: none"> Note: Drive capacity and speed vary with model. – Serial Attached SCSI (SAS) drives are supported if an optional SAS adapter is installed. – Maximum: Two SATA or two SAS drives <p>Expansion slots:</p> <ul style="list-style-type: none"> • Two, used in either of the following configurations: <ul style="list-style-type: none"> – One full-height, half-length Hyper Transport (HTX) riser card and one half-length PCI Express x16 riser card – One full-height, half-length PCI Express x8 and one half-length PCI Express x16 riser card • Each riser card supports one adapter • Server supports a maximum of two adapters 	<p>Video controller:</p> <ul style="list-style-type: none"> • ATI RN50b video controller on system board • Compatible with SVGA • 16 MB DDR1 video memory <p>Power supply:</p> <p>One 650 watt (115 - 230 V ac)</p> <p>Cooling:</p> <ul style="list-style-type: none"> • Three nonredundant, non-hot-swappable fans with system-board connectors • Two air baffles on the system board • Two fans built into the power supply <p>Size:</p> <ul style="list-style-type: none"> • Height: 43 mm (1.7 in.) • Depth: <ul style="list-style-type: none"> – 660.5 mm (26.0 in.) with bezel – 643.5 mm (25.3 in.) without bezel • Width: 440 mm (17.3 in.) • Weight: approximately 11.9 kg (26.2 lb) when fully configured <p>Integrated functions:</p> <ul style="list-style-type: none"> • Baseboard management controller • One SATA controller • Two Broadcom 10/100/1000 Ethernet controllers (dual-port design) with Wake on LAN® support • Six Universal Serial Bus (USB) ports <ul style="list-style-type: none"> – Two on front of server – Four on rear of server • One serial port • One video port
--	--	--

Table 1. Features and specifications (continued)

<p>Acoustical noise emissions:</p> <ul style="list-style-type: none"> • Declared sound power, idling: 6.5 bels • Declared sound power, operating: 6.5 bels <p>Environment:</p> <ul style="list-style-type: none"> • Air temperature: <ul style="list-style-type: none"> – Server on: 10° to 35°C (50.0° to 95.0°F). Altitude: 0 to 914 m (2998.7 ft) – Server on: 10° to 32°C (50.0° to 89.6°F). Altitude: 914 m (2998.7 ft) to 2133 m (6998.0 ft) – Server off: 10° to 43°C (50.0° to 109.4°F). Maximum altitude: 2133 m (6998.0 ft) • Humidity: <ul style="list-style-type: none"> – Server on: 8% to 80% – Server off: 8% to 80% • Airflow rates: <ul style="list-style-type: none"> – Minimum: 34 CFM – Maximum: 74 CFM 	<p>Heat output:</p> <p>Approximate heat output in British thermal units (Btu) per hour for dual multiprocessor configurations:</p> <ul style="list-style-type: none"> • Minimum configuration: 430 Btu (126 watts) • Maximum configuration: 1707 Btu (500 watts) <p>Electrical input:</p> <ul style="list-style-type: none"> • Sine-wave input (50-60 Hz) required • Input voltage low range: <ul style="list-style-type: none"> – Minimum: 100 V ac – Maximum: 127 V ac • Input voltage high range: <ul style="list-style-type: none"> – Minimum: 200 V ac – Maximum: 240 V ac • Input kilovolt-amperes (kVA), approximately: <ul style="list-style-type: none"> – Minimum: 0.126 kVA – Maximum: 0.500 kVA 	<p>Notes:</p> <ol style="list-style-type: none"> 1. Power consumption and heat output vary depending on the number and type of optional features installed and the power-management optional features in use. 2. These levels were measured in controlled acoustical environments according to the procedures specified by the American National Standards Institute (ANSI) S12.10 and ISO 7779 and are reported in accordance with ISO 9296. Actual sound-pressure levels in a given location might exceed the average values stated because of room reflections and other nearby noise sources. The declared sound-power levels indicate an upper limit, below which a large number of computers will operate.
--	--	---

Server controls, LEDs, and connectors

This section describes the controls, light-emitting diodes (LEDs), and connectors on the front and rear of the server.

Front view

The following illustration shows the controls, LEDs, and connectors on the front of the server. Except for the CD or DVD drive activity LED, the CD-eject or DVD-eject button, and the rack release latches, these controls, LEDs, and connectors are on the operator information panel.

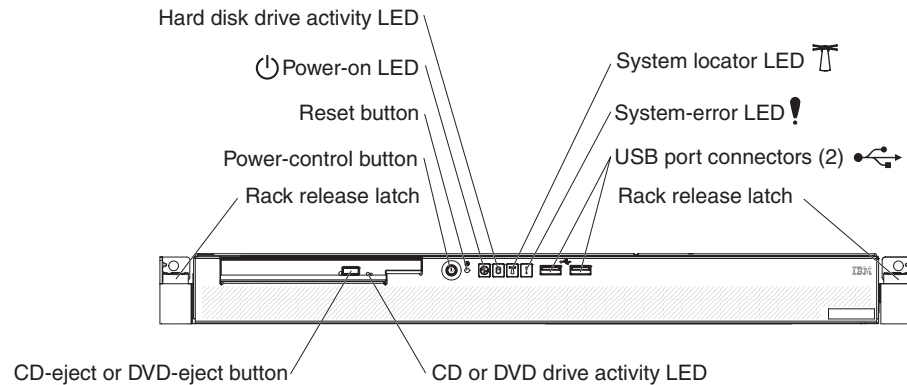

CD or DVD drive activity LED: When this LED is lit, it indicates that the CD drive or DVD drive is in use.

CD-eject or DVD-eject button: Press this button to release a CD from the CD drive or a DVD from the DVD drive.

Rack release latches: Each side of the front of the server has a rack release latch. Press these latches to remove the server from the rack.

Operator information panel: This panel contains controls, LEDs, and connectors. The following illustration shows the operator information panel.

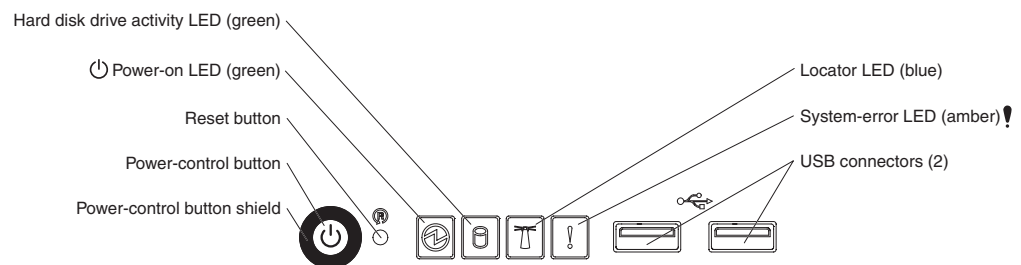

The following controls, LEDs, and connectors are on the operator information panel:

- **Power-control button:** Press this button to turn the server on and off manually. You might have to use a pen or the end of a straightened paper clip to press the button.

A power-control-button shield comes with the server. You can install it to prevent the server from being turned off accidentally.

- **Reset button:** Press this button to reset the server and run the power-on self-test (POST). You might have to use a pen or the end of a straightened paper clip to press the button.
- **Power-on LED:** When this LED is lit and not flashing, it indicates that the server is turned on. When this LED is flashing, it indicates that the server is turned off and still connected to an ac power source. When this LED is off, it indicates that ac power is not present, or the power supply or the LED itself has failed.

Notes:

1. If this LED is off, it does not mean that there is no electrical power in the server. The LED might be burned out. To remove all electrical power from the server, you must disconnect the power cord from the electrical outlet.
 2. The ac power and dc power LEDs are on the power supply and can be viewed from the rear of the server. For additional information, see “Rear view.”
- **Hard disk drive activity LED:** When this LED is lit, it indicates that either of the hard disk drives is in use.
 - **System locator LED:** This LED can be lit remotely by the system administrator to aid in visually locating the server. If the server supports IBM Director, you can use IBM Director to light this LED remotely. A system locator LED is also on the rear of the server.
 - **System-error LED (!):** When this LED is lit, it indicates that a system error has occurred. An LED near the failing component on the system board is also lit to help isolate the error.
 - **USB connectors:** Connect a USB device to either of these connectors.

Notes:

1. If you want to attach a keyboard or mouse to this server, you must use a USB keyboard or a USB mouse. For detailed information about the USB keyboard and how to connect it to your server, see the documentation that comes with the USB keyboard.
2. The server supports keyboardless operation. If a USB keyboard is not connected to the server, when the server is turned on or restarted, error message 301 will be displayed during POST. No action is required. POST will continue within 1 minute.
3. If you want to attach a diskette drive to this server, you must use an external USB diskette drive.

Rear view

The following illustration shows the connectors, switches, and LEDs on the rear of the server.

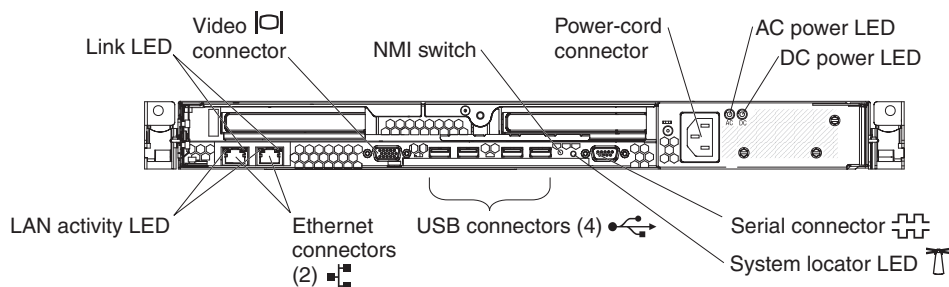

Link LEDs (Ethernet): These LEDs are on the dual Ethernet connector. When either LED is lit, it indicates that there is an active link between the server and the network device that is connected to the left or right connector.

Video connector: Connect a monitor to this connector.

NMI switch: This switch is reserved for use by service technicians only.

Power-cord connector: Connect the power cord to this connector.

AC power LED: The power supply has an ac power LED and a dc power LED. When the ac power LED is lit, it indicates that sufficient power is coming into the power supply through the power cord. During typical operation, both the ac and dc power LEDs are lit. For additional information about the ac power and dc power LEDs, see “Power-supply LEDs” on page 43.

DC power LED: The power supply has a dc power LED and an ac power LED. When the dc power LED is lit, it indicates that the power supply is supplying adequate dc power to the system. During typical operation, both the ac and dc power LEDs are lit. For additional information about the ac power and dc power LEDs, see “Power-supply LEDs” on page 43.

Serial connector: Connect a 9-pin serial device to this connector.

System locator LED: This LED can be lit remotely by the system administrator to aid in visually locating the server. If the server supports IBM Director, you can use IBM Director to light this LED remotely. A system locator LED is also on the front of the server.

USB connectors: Connect a USB device to any of these four connectors.

Gigabit Ethernet 1 (LAN 1) connector: Use this connector to connect the server to a network.

Gigabit Ethernet 2 (LAN 2) connector: Use this connector to connect the server to a network.

LAN activity LEDs (Ethernet): These green LEDs are on the dual Ethernet connector. When either LED flashes, it indicates that data is being transmitted or received between the server and the local area network (LAN) device that is connected to the left or right connector. The flashing frequency is proportional to the amount of traffic on the network link.

Internal LEDs, connectors, and jumpers

The illustrations in this section show the connectors, LEDs, and jumpers on the internal boards. The illustrations might differ slightly from your hardware.

System-board internal and option connectors

The following illustration shows the connectors for internal and user-installable optional devices.

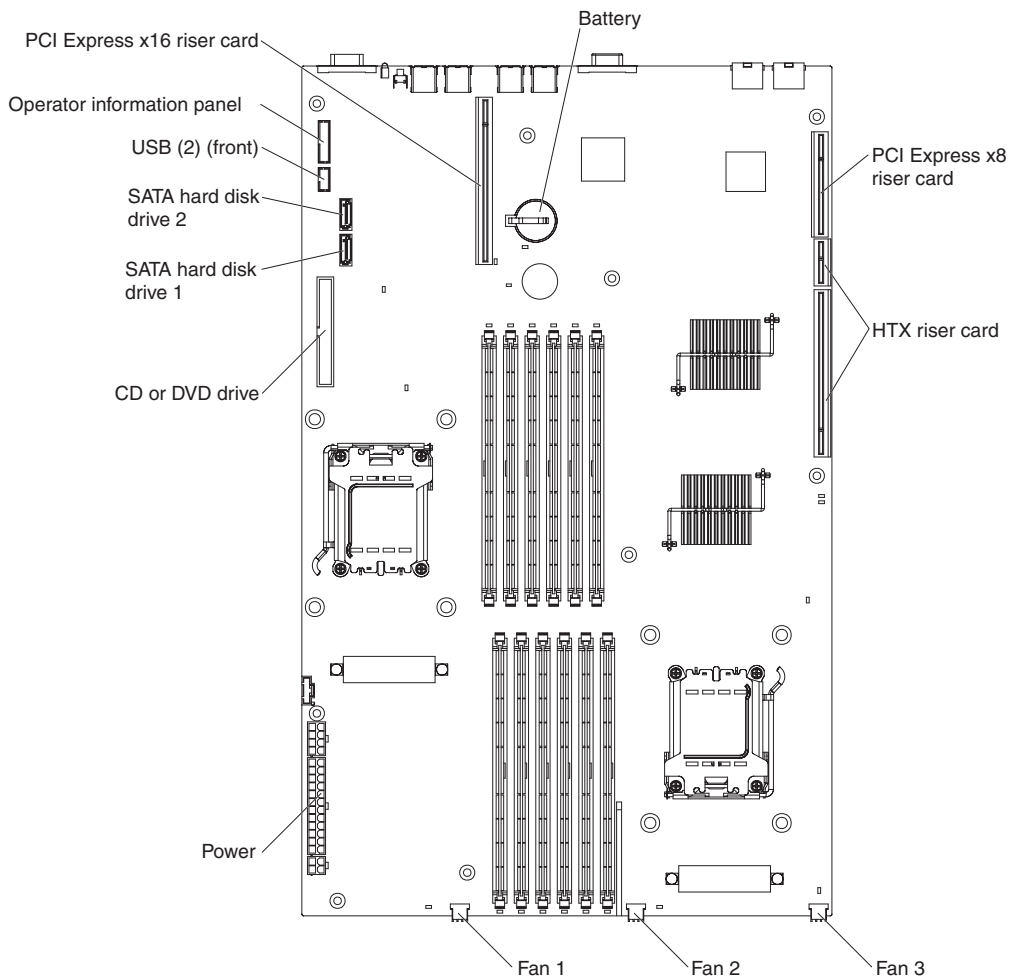

Operator information panel controls and internal connectors

The following illustration shows the controls and internal connectors on the operator information panel. When the server is turned off, you can light the system-board error LEDs for up to 30 seconds to indicate detected faults by pressing the light path button.

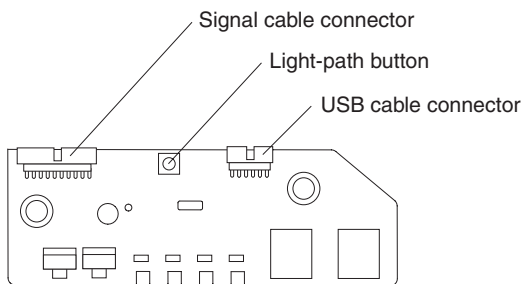

System-board switches and jumpers

The following illustration shows the switches and jumpers on the system board.

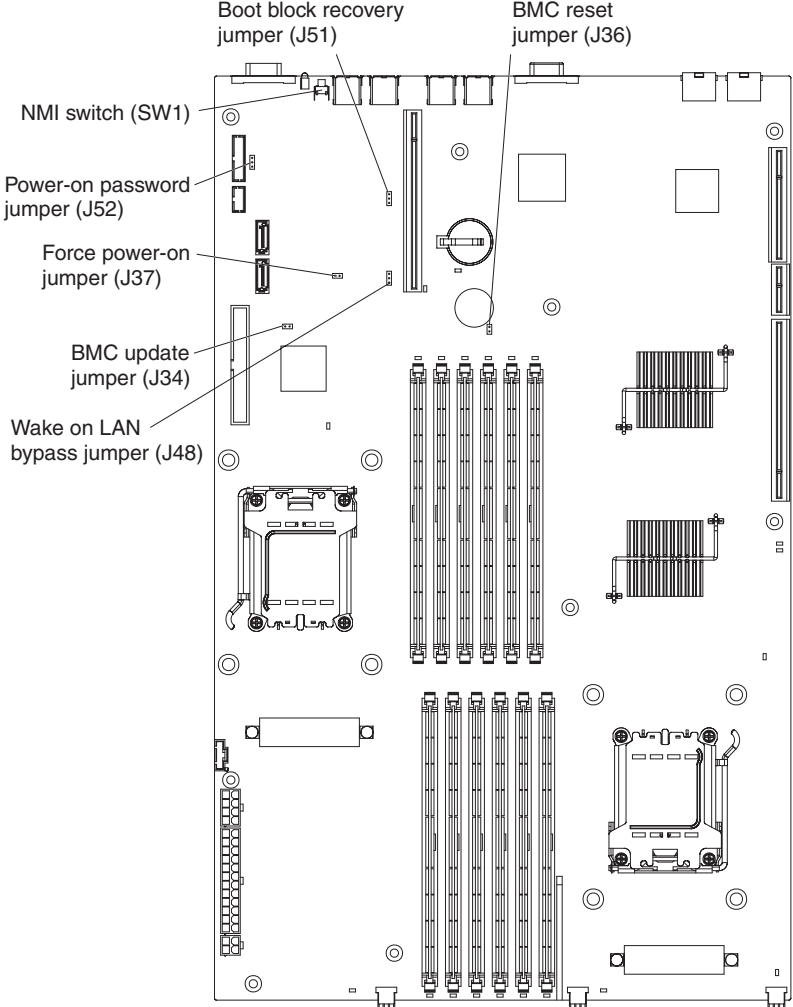
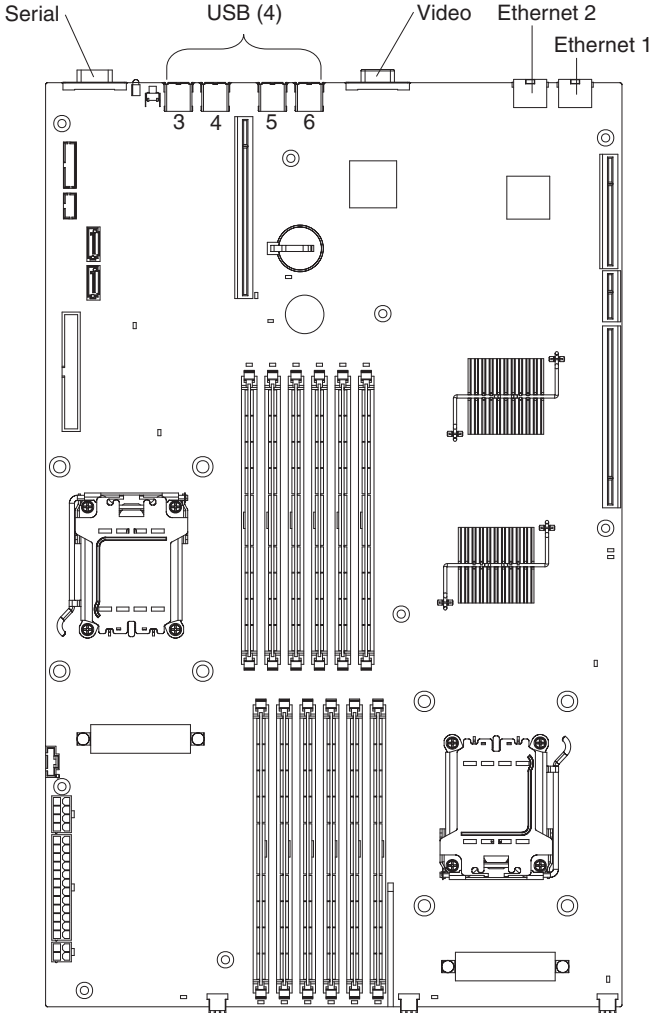

Table 2. Switch and jumper settings

Component	Default value	Settings
NMI (nonmaskable interrupt) switch (SW1)	Off	Pressing this button issues an NMI.
Boot block recovery jumper (J51)	1 and 2	<ul style="list-style-type: none"> • Pins 1 and 2: Normal (default) • Pins 2 and 3: Recover boot block.
BMC reset jumper (J36)	Off	Force BMC reset (trained service technician only). When this jumper is installed, it causes a continuous reset of the BMC.
Wake on LAN bypass jumper (J48)	1 and 2	<ul style="list-style-type: none"> • Pins 1 and 2: Wake on LAN disabled. • Pins 2 and 3: Wake on LAN enabled
BMC update jumper (J34)	Off	Force BMC update (trained service technician only). When this jumper is installed, it causes an update of BMC firmware from ROM.
Force power-on jumper (J37)	Off	Power-on override. When installed, this jumper forces the server power on, overriding the power-on button.
Power-on password override jumper (J52)	1 and 2	<p>Power-on (user) password override. Changing the position of this jumper bypasses the power-on password check the next time the server is turned on and starts the Configuration/Setup Utility program (see "Using the Configuration/Setup Utility program" on page 109) so that you can change or delete the power-on password. Move the jumper back to the default position after the password is overridden.</p> <p>Changing the position of this jumper does not bypass the administrator password check if an administrator password is set.</p>

System-board external connectors

The following illustration shows the external connectors on the system board.



System-board LEDs

The following illustration shows the light-emitting diodes (LEDs) on the system board.

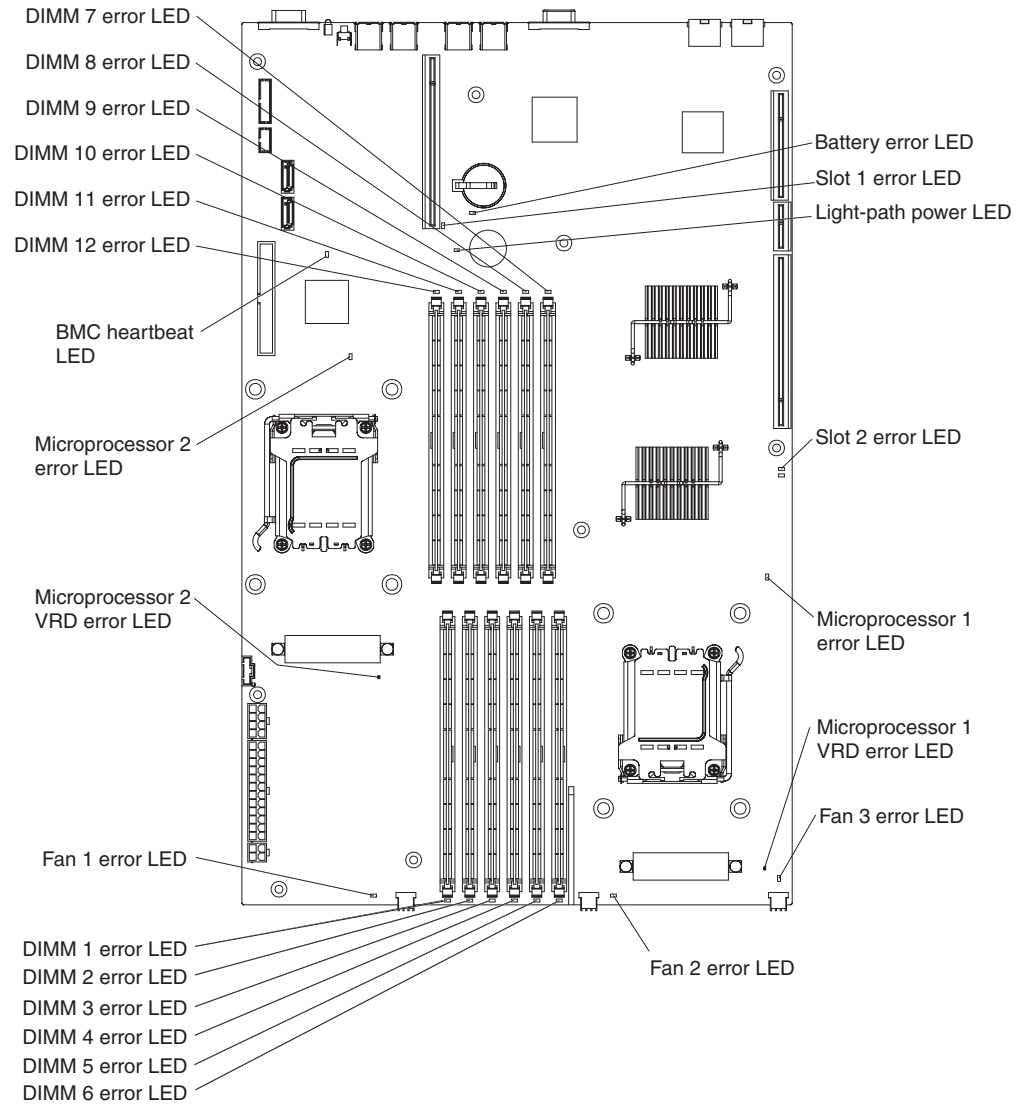

Table 3. System-board LEDs

LED	Description
System locator LED	Use this blue LED to visually locate the server. You can use IBM Director to light this LED remotely. This LED flashes during system POST and when the Configuration/Setup Utility program is in use.
Error LEDs	If an amber error LED on the system board is lit, the associated component has failed. If the Microprocessor 1 VRD error LED or the Microprocessor 2 VRD error LED is lit, the system board has failed.
Light path power LED	With the server power cord connected, this green LED remains lit. With the server power cord disconnected and the light path button pressed, this LED lights to indicate that the light path function is working.
BMC heartbeat LED	This LED flashes to indicate that the BMC (baseboard management controller) is functioning normally.

Chapter 2. Diagnostics

This chapter describes the diagnostic tools that are available to help you solve problems that might occur in the server.

If you cannot locate and correct a problem by using the information in this chapter, see Appendix A, “Getting help and technical assistance,” on page 113 for more information.

Diagnostic tools

The following tools are available to help you diagnose and solve hardware-related problems:

- **POST beep codes, error messages, and error logs**

The power-on self-test (POST) generates beep codes and messages to indicate successful test completion or the detection of a problem. See “POST” for more information.
- **Troubleshooting tables**

These tables list problem symptoms and actions to correct the problems. See “Troubleshooting tables” on page 30.
- **Error LEDs**

Use the error LEDs to diagnose system errors quickly. See “System board error LEDs and the light path button” on page 42 for more information.
- **Diagnostic programs, messages, and error messages**

The diagnostic programs are the primary method of testing the major components of the server. The diagnostic programs are on the IBM *Enhanced Diagnostics* CD that comes with the server. See “Diagnostic programs, messages, and error codes” on page 45 for more information.

POST

When you turn on the server, it performs a series of tests to check the operation of the server components and some optional devices in the server. This series of tests is called the power-on self-test, or POST.

If a power-on password is set, you must type the password and press Enter, when you are prompted, for POST to run.

If POST detects a problem, one or more beeps might sound, or an error message is displayed. See “POST beep codes” on page 15 and “POST error codes” on page 21 for more information.

POST beep codes

A beep code is a combination of short or long beeps or a series of short beeps that are separated by pauses. For example, a “1-2-3” beep code is one short beep, a pause, two short beeps, and pause, and three short beeps. A beep code indicates that POST has detected a problem.

A single problem might cause more than one error message. When this occurs, correct the cause of the first error message. The other error messages usually will not occur the next time POST runs.

Exception: If there are multiple error codes or error LEDs that indicate a microprocessor error, the error might be in the microprocessor or in the microprocessor socket. See “Microprocessor problems” on page 35 for information about diagnosing microprocessor problems.

- Follow the suggested actions in the order in which they are listed in the Action column until the problem is solved.
- See Chapter 3, “Parts listing, Type 7984 and 7986 servers,” on page 63 to determine which components are CRUs and which components are FRUs.
- If an action step is preceded by “(Trained service technician only),” that step must be performed only by a trained service technician.

Beep code	Description	Action
No beep	No beep and no video (system error LED is off)	<ol style="list-style-type: none"> 1. Verify that ac power is present 2. Verify that the power supply is functioning correctly (see “Power-supply LEDs” on page 43). 3. (Trained service technician only) Replace the system board
No beep	No beep and no video (system error LED is on)	<ol style="list-style-type: none"> 1. Check for failed components indicated by the system board error LEDs. (See “System board error LEDs and the light path button” on page 42). 2. (Trained service technician only) Replace the system board
1-1-3	CMOS write/read test failed.	<ol style="list-style-type: none"> 1. Reseat the system-board battery. 2. Replace the following components one at a time, in the order shown, restarting the server each time: <ol style="list-style-type: none"> a. System-board battery b. (Trained service technician only) System board
1-1-4	BIOS EEPROM checksum failed.	<ol style="list-style-type: none"> 1. Reinstall the server BIOS (see “Updating the firmware” on page 109). 2. (Trained service technician only) Replace the system board.
1-2-1	Programmable interval timer failed.	(Trained service technician only) Replace the system board.
1-2-2	DMA initialization failed.	(Trained service technician only) Replace the system board.
1-2-3	DMA page register write/read failed.	(Trained service technician only) Replace the system board.
1-3-1	1st 64K RAM test failed.	<ol style="list-style-type: none"> 1. Reseat the DIMMs. 2. Replace the following components, one at a time, in the order shown, restarting the server each time: <ol style="list-style-type: none"> a. DIMMs b. (Trained service technician only) System board
2-1-1	Secondary DMA register failed.	(Trained service technician only) Replace the system board.

- Follow the suggested actions in the order in which they are listed in the Action column until the problem is solved.
- See Chapter 3, “Parts listing, Type 7984 and 7986 servers,” on page 63 to determine which components are CRUs and which components are FRUs.
- If an action step is preceded by “(Trained service technician only),” that step must be performed only by a trained service technician.

Beep code	Description	Action
2-1-2	Primary DMA register failed.	(Trained service technician only) Replace the system board.
2-1-3	Primary interrupt mask register failed.	(Trained service technician only) Replace the system board.
2-1-4	Secondary interrupt mask register failed.	(Trained service technician only) Replace the system board.
2-2-2	Keyboard controller failed.	Replace the following components, one at a time, in the order shown, restarting the server each time: <ol style="list-style-type: none"> 1. Keyboard 2. (Trained service technician only) System board
2-2-3	CMOS power failure and checksum checks failed.	<ol style="list-style-type: none"> 1. Reseat the system-board battery. 2. Replace the following components, one at a time, in the order shown, restarting the server each time: <ol style="list-style-type: none"> a. System-board battery b. (Trained service technician only) System board
2-4-1	Video failed.	(Trained service technician only) Replace the system board.
3-1-1	Timer tick interrupt failed.	(Trained service technician only) Replace the system board.
3-1-2	Interval timer channel 2 failed.	(Trained service technician only) Replace the system board.
3-1-3	RAM test failed above address 0FFFFh.	<ol style="list-style-type: none"> 1. Reseat the DIMMs. 2. Replace the following components one at a time, in the order shown, restarting the server each time: <ol style="list-style-type: none"> a. DIMMs b. (Trained service technician only) System board
3-1-4	Time-of-day clock failed.	<ol style="list-style-type: none"> 1. Reseat the system-board battery. 2. Replace the following components one at a time, in the order shown, restarting the server each time: <ol style="list-style-type: none"> a. System-board battery b. (Trained service technician only) System board
3-2-1	Serial port failed.	(Trained service technician only) Replace the system board.

- Follow the suggested actions in the order in which they are listed in the Action column until the problem is solved.
- See Chapter 3, “Parts listing, Type 7984 and 7986 servers,” on page 63 to determine which components are CRUs and which components are FRUs.
- If an action step is preceded by “(Trained service technician only),” that step must be performed only by a trained service technician.

Beep code	Description	Action
3-2-4	Failed comparing CMOS memory size against actual.	<ol style="list-style-type: none"> 1. Reseat the following components: <ol style="list-style-type: none"> a. DIMMs b. System-board battery 2. Replace the following components, one at a time, in the order shown, restarting the server each time: <ol style="list-style-type: none"> a. DIMMs b. System-board battery c. (Trained service technician only) System board
3-3-1	Memory size mismatch occurred.	<ol style="list-style-type: none"> 1. Verify correct matching of DIMM pairs (see “Installing a memory module” on page 81). 2. Reseat the following components: <ol style="list-style-type: none"> a. DIMMs b. System-board battery 3. Replace the following components, one at a time, in the order shown, restarting the server each time: <ol style="list-style-type: none"> a. DIMMs b. System-board battery c. (Trained service technician only) System board
3-3-2	Critical SMBUS (I ² C bus) error occurred.	<ol style="list-style-type: none"> 1. Disconnect the server power, wait 30 seconds, and retry. 2. Reseat the following components: <ol style="list-style-type: none"> a. DIMMs b. (Trained service technician only) Microprocessor c. (Trained service technician only) System board 3. Replace the following components, one at a time, in the order shown, restarting the server each time: <ol style="list-style-type: none"> a. DIMMs b. (Trained service technician only) System board c. (Trained service technician only) Microprocessor

- Follow the suggested actions in the order in which they are listed in the Action column until the problem is solved.
- See Chapter 3, “Parts listing, Type 7984 and 7986 servers,” on page 63 to determine which components are CRUs and which components are FRUs.
- If an action step is preceded by “(Trained service technician only),” that step must be performed only by a trained service technician.

Beep code	Description	Action
3-3-3	No operational memory in system.	<ol style="list-style-type: none"> 1. Make sure that the server contains the correct number of DIMMs, in the correct order (see “Installing a memory module” on page 81). Install or reseal DIMMS; then, restart the server. Important: If some memory configuration errors occur, the 3-3-3 beep code might sound during POST, followed by a blank monitor screen. If this occurs and the Boot Fail Count option in the Start Options of the Configuration/Setup Utility program is enabled, you must restart the server three times to reset the configuration settings to the default configuration (the memory connector or bank of connectors enabled). 2. Replace the following components one at a time, in the order shown, restarting the server each time: <ol style="list-style-type: none"> a. DIMMs b. (Trained service technician only) System board

Error logs

The system event/error log includes error codes and messages that were generated during POST. The BMC (baseboard management controller) system event log contains both event messages and error codes that were generated by the BMC (see “BMC system-event log messages” on page 53).

The BMC system event log is limited in size. When the log is full, new entries will not overwrite existing entries; therefore, you must periodically clear the log through the Configuration/Setup Utility program (see “Clearing the error logs”). When you are troubleshooting an error, be sure to clear the error logs so that you can find current errors more easily.

Important: After you complete a repair or correct an error, clear the BMC system event log (see “Clearing the error logs”) to turn off the system-error LED on the front of the server.

You can view the contents of both the system event/error log and the BMC system-event log from the Configuration/Setup Utility program.

When you are troubleshooting PCI Express slots, note that the error logs report the PCI Express busses numerically. The numerical assignments vary depending on the configuration. You can check the assignments by running the Configuration/Setup Utility program (see the *User's Guide* on the IBM *System x Documentation* CD for more information).

Viewing error logs from the Configuration/Setup Utility program

For complete information about using the Configuration/Setup Utility program, see the *User's Guide* on the IBM *System x Documentation* CD. For a list of system event codes and error codes, see “BMC system-event log messages” on page 53.

To view the error logs, complete the following steps:

1. Turn on the server.
2. When the prompt Press F1 for Setup is displayed, press F1. If you have set both a power-on password and an administrator password, you must type the administrator password to view the error logs.
3. Use one of the following procedures:
 - To view the BMC System Event Log, select **Advanced Setup --> Baseboard Management Controller (BMC) Settings --> System Event Log**
 - To view the System Event/Error Log, select **Error Logs --> System Event/Error Log**

Clearing the error logs

For complete information about using the Configuration/Setup Utility program, see the *User's Guide* on the IBM *System x Documentation* CD.

To clear the BMC system event log, complete the following steps:

1. Turn on the server.
2. When the prompt Press F1 for Setup is displayed, press F1. If you have set both a power-on password and an administrator password, you must type the administrator password to access the logs.
3. Select **Advanced Setup --> Baseboard Management Controller (BMC) Settings-->System Event Log**. Select **Clear System Event Log**; then, change the setting from **Disabled** to **Enabled**.

4. Exit from the Configuration/Utility program, saving the new settings; then, restart the server.

POST error codes

The following table describes the POST error codes and suggested actions to correct the detected problems.

<ul style="list-style-type: none"> • Follow the suggested actions in the order in which they are listed in the Action column until the problem is solved. • See Chapter 3, “Parts listing, Type 7984 and 7986 servers,” on page 63 to determine which components are customer replaceable units (CRU) and which components are field replaceable units (FRU). • If an action step is preceded by “(Trained service technician only),” that step must be performed only by a trained service technician. 		
Error code	Description	Action
062	Three consecutive boot failures using the default configuration.	<ol style="list-style-type: none"> 1. Run the Configuration/Setup Utility program, save the configuration, and restart the server. 2. Update the system firmware to the latest level (see “Updating the firmware” on page 109). 3. Reseat the following components, one at a time, in the order shown, restarting the server each time: <ol style="list-style-type: none"> a. System-board battery b. (Trained service technician only) Microprocessor 1 4. Replace the components listed in step 3, one at a time, in the order shown, restarting the server each time.
101, 102	System and microprocessor error.	<ol style="list-style-type: none"> 1. (Trained service technician only) Replace the system board.
151	Real-time clock error.	<ol style="list-style-type: none"> 1. Reseat the battery. 2. Replace the following components one at a time, in the order shown, restarting the server each time: <ol style="list-style-type: none"> a. System-board battery b. (Trained service technician only) System board
161	Real-time clock battery error.	<ol style="list-style-type: none"> 1. Run the Configuration/Setup Utility program, select Load Default Settings, and save the settings. 2. Reseat the battery. 3. Replace the following components one at a time, in the order shown, restarting the server each time: <ol style="list-style-type: none"> a. System-board battery b. (Trained service technician only) System board

- Follow the suggested actions in the order in which they are listed in the Action column until the problem is solved.
- See Chapter 3, “Parts listing, Type 7984 and 7986 servers,” on page 63 to determine which components are customer replaceable units (CRU) and which components are field replaceable units (FRU).
- If an action step is preceded by “(Trained service technician only),” that step must be performed only by a trained service technician.

Error code	Description	Action
162	Device configuration error.	<ol style="list-style-type: none"> 1. Run the Configuration/Setup Utility program, select Load Default Settings, and save the settings. 2. Reseat the following components, one at a time, in the order shown, restarting the server each time: <ol style="list-style-type: none"> a. System-board battery b. Failing device (if the device is a FRU, the device must be reseated by a trained service technician only) 3. Replace the following components one at a time, in the order shown, restarting the server each time: <ol style="list-style-type: none"> a. System-board battery b. Failing device (if the device is a FRU, the device must be replaced by a trained service technician only) c. (Trained service technician only) System board
163	Real-time clock error. (time of day not set)	<ol style="list-style-type: none"> 1. Run the Configuration/Setup Utility program, select Load Default Settings, make sure that the date and time are correct, and save the settings. 2. Reseat the battery. 3. Replace the following components one at a time, in the order shown, restarting the server each time: <ol style="list-style-type: none"> a. System-board battery b. (Trained service technician only) System board
164	Memory configuration changed.	<ol style="list-style-type: none"> 1. Run the Configuration/Setup Utility program, select Load Default Settings, and save the settings. 2. Reseat the DIMMs. 3. Replace the following components one at a time, in the order shown, restarting the server each time: <ol style="list-style-type: none"> a. DIMMs b. (Trained service technician only) System board
175	Bad EEPROM CRC #1.	<ol style="list-style-type: none"> 1. Run the Configuration/Setup Utility program, select Load Default Settings, and save the settings. 2. (Trained service technician only) Replace the system board.

- Follow the suggested actions in the order in which they are listed in the Action column until the problem is solved.
- See Chapter 3, “Parts listing, Type 7984 and 7986 servers,” on page 63 to determine which components are customer replaceable units (CRU) and which components are field replaceable units (FRU).
- If an action step is preceded by “(Trained service technician only),” that step must be performed only by a trained service technician.

Error code	Description	Action
184	Power-on password damaged.	<ol style="list-style-type: none"> 1. Restart the server and enter the administrator password. Run the Configuration/Setup Utility program, select Load Default Settings; then, reset the power-on password and save the settings. 2. Reseat the battery. 3. Replace the following components one at a time, in the order shown, restarting the server each time: <ol style="list-style-type: none"> a. System-board battery b. (Trained service technician only) System board
187	VPD serial number not set.	<ol style="list-style-type: none"> 1. Run the Configuration/Setup Utility program, set the serial number, and save the configuration. 2. (Trained service technician only) Replace the system board.
188	Bad EEPROM CRC #2.	<ol style="list-style-type: none"> 1. Run the Configuration/Setup Utility program, select Load Default Settings, and save the settings. 2. Update the BMC firmware. 3. (Trained service technician only) Replace the system board.
189	An attempt was made to access the server with an incorrect password.	Restart the server and enter the administrator password; then, run the Configuration/Setup Utility program and change the power-on password.
198	Microprocessor speed mismatch detected.	<ol style="list-style-type: none"> 1. Make sure that the correct microprocessors are installed. See Table 4 on page 65 for a list of supported microprocessors. 2. (Trained service technician only) If the wrong microprocessors are installed, replace them with the correct microprocessors. If the server contains two microprocessors, both microprocessors must be the same type and have the same speed.
201	Memory test error.	<ol style="list-style-type: none"> 1. Make sure that the DIMM is installed correctly (see “Installing a memory module” on page 81). 2. Reseat the DIMM. 3. Replace the DIMM. 4. (Trained service technician only) Replace the system board.

- Follow the suggested actions in the order in which they are listed in the Action column until the problem is solved.
- See Chapter 3, “Parts listing, Type 7984 and 7986 servers,” on page 63 to determine which components are customer replaceable units (CRU) and which components are field replaceable units (FRU).
- If an action step is preceded by “(Trained service technician only),” that step must be performed only by a trained service technician.

Error code	Description	Action
289	A DIMM has been disabled by the user or by the system.	<ol style="list-style-type: none"> 1. If the DIMM was disabled by the user, run the Configuration/Setup Utility program and enable the DIMM. 2. Make sure that the DIMM is installed correctly (see “Installing a memory module” on page 81). 3. Reseat the DIMM. 4. Replace the DIMM. 5. (Trained service technician only) Replace the system board.
301	Keyboard or keyboard controller error.	<ol style="list-style-type: none"> 1. Run the Configuration/Setup Utility program and enable keyboardless operation to prevent the POST error message 301 from being displayed during startup. 2. Reseat the keyboard cable in the connector. 3. If you are using an external USB hub, disconnect the keyboard from the hub and connect it directly to the server. 4. Replace the following components one at a time, in the order shown, restarting the server each time: <ol style="list-style-type: none"> a. Keyboard b. (Trained service technician only) System board
303	Keyboard controller error.	<ol style="list-style-type: none"> 1. If you have installed a USB keyboard, run the Configuration/Setup Utility program and enable keyboardless operation to prevent the POST error message 301 from being displayed during startup. 2. Reseat the keyboard cable in the connector. 3. If you are using an external USB hub, disconnect the keyboard from the hub and connect it directly to the server. 4. Replace the following components one at a time, in the order shown, restarting the server each time: <ol style="list-style-type: none"> a. Keyboard b. (Trained service technician only) System board
1162	Serial port configuration error.	<ol style="list-style-type: none"> 1. Run the Configuration/Setup Utility program, select Load Default Settings, and save the settings. 2. (Trained service technician only) Replace the system board.

- Follow the suggested actions in the order in which they are listed in the Action column until the problem is solved.
- See Chapter 3, “Parts listing, Type 7984 and 7986 servers,” on page 63 to determine which components are customer replaceable units (CRU) and which components are field replaceable units (FRU).
- If an action step is preceded by “(Trained service technician only),” that step must be performed only by a trained service technician.

Error code	Description	Action
1762	Hard drive configuration error.	<ol style="list-style-type: none"> 1. Run the hard disk drive diagnostics tests on drive x (see “Running the diagnostic programs” on page 45). 2. Reseat the following components: <ol style="list-style-type: none"> a. Hard disk drive b. Hard disk drive cables 3. Run the Configuration/Setup Utility program, select Load Default Settings, and save the settings. 4. Replace the following components one at a time, in the order shown, restarting the server each time: <ol style="list-style-type: none"> a. Hard disk drive b. Hard disk drive cables c. (Trained service technician only) System board
1801	An adapter has requested memory resources that are not available	<ol style="list-style-type: none"> 1. Run the Configuration/Setup Utility program and verify that sufficient memory is installed in the server. 2. Run the Configuration/Setup Utility program and disable some other resources to make more space available. 3. Replace the following components one at a time, in the order shown, restarting the server each time: <ol style="list-style-type: none"> a. Each adapter b. (Trained service technician only) System board
1803	No memory above 1 MB for PCI Express adapter	<ol style="list-style-type: none"> 1. Make sure that the memory addresses for all installed adapters are set correctly in the Configuration/Setup Utility program. 2. Reseat the adapter. 3. Replace the adapter. 4. (Trained service technician only) Replace the system board

- Follow the suggested actions in the order in which they are listed in the Action column until the problem is solved.
- See Chapter 3, “Parts listing, Type 7984 and 7986 servers,” on page 63 to determine which components are customer replaceable units (CRU) and which components are field replaceable units (FRU).
- If an action step is preceded by “(Trained service technician only),” that step must be performed only by a trained service technician.

Error code	Description	Action
1962	A hard disk drive does not contain a valid boot sector.	<ol style="list-style-type: none"> 1. Make sure that a startable operating system is installed. 2. Run the hard disk drive diagnostic tests (see “Running the diagnostic programs” on page 45). 3. Reseat the following components: <ol style="list-style-type: none"> a. Hard disk drive b. Hard disk drive cables 4. Replace the following components one at a time, in the order shown, restarting the server each time: <ol style="list-style-type: none"> a. Hard disk drive cables b. Hard disk drive c. (Trained service technician only) System board d. Power supply
2462	Video memory configuration error.	<ol style="list-style-type: none"> 1. Optional video adapter (if installed) 2. (Trained service technician only) Replace the system board
8603	Pointing device error.	<ol style="list-style-type: none"> 1. Reseat the pointing-device cable. 2. If you are using an external USB hub, disconnect the pointing device from the hub and connect it directly to the server. 3. Replace the pointing device. 4. (Trained service technician only) Replace the system board.
00012000	Microprocessor machine check error.	<ol style="list-style-type: none"> 1. Update the server BIOS (see “Updating the firmware” on page 109). 2. (Trained service technician only) Reseat the following components: <ol style="list-style-type: none"> a. Microprocessor 1 b. Microprocessor 2 (if present) 3. (Trained service technician only) Replace the following components one at a time, in the order shown, restarting the server each time: <ol style="list-style-type: none"> a. Microprocessor 1 b. Microprocessor 2 (if present) c. System board
00180700	PCI Express device not responding.	(Trained service technician only) Replace the system board.

- Follow the suggested actions in the order in which they are listed in the Action column until the problem is solved.
- See Chapter 3, “Parts listing, Type 7984 and 7986 servers,” on page 63 to determine which components are customer replaceable units (CRU) and which components are field replaceable units (FRU).
- If an action step is preceded by “(Trained service technician only),” that step must be performed only by a trained service technician.

Error code	Description	Action
012980xx	No update data for microprocessor xx.	<ol style="list-style-type: none"> 1. Update the BIOS code again (see “Updating the firmware” on page 109). 2. (Trained service technician only) Replace microprocessor xx.
01298200	Microprocessor speed mismatch	<ol style="list-style-type: none"> 1. Make sure that the correct microprocessors are installed. See Table 4 on page 65 for a list of supported microprocessors. 2. (Trained service technician only) If the wrong microprocessors are installed, replace them with the correct microprocessors. If the server contains two microprocessors, both microprocessors must be the same type and have the same speed.
19990650	AC power has been restored.	<ol style="list-style-type: none"> 1. Check the power cables. 2. Check for interruption of ac power.

Checkout procedure

The checkout procedure is the sequence of tasks that you must follow to diagnose a problem in the server.

About the checkout procedure

Before performing the checkout procedure for diagnosing hardware problems, review the following information:

- Read the safety information that begins on page vii.
- The diagnostic programs provide the primary methods of testing the major components of the server, such as the system board, Ethernet controller, keyboard, mouse (pointing device), serial ports, and hard disk drives. You can also use them to test some external devices. If you are not sure whether a problem is caused by the hardware or by the software, you can use the diagnostic programs to confirm that the hardware is working correctly.
- When you run the diagnostic programs, a single problem might cause more than one error message. When this happens, correct the cause of the first error message. The other error messages usually will not occur the next time you run the diagnostic programs.

Exception: If there are multiple error codes or error LEDs that indicate a microprocessor error, the error might be in the microprocessor or in the microprocessor socket. See “Microprocessor problems” on page 35 for information about diagnosing microprocessor problems.

- Before you run the diagnostic programs, you must determine whether the failing server is part of a shared hard disk drive cluster (two or more servers sharing external storage devices). If it is part of a cluster, you can run all diagnostic programs except the ones that test the storage unit (that is, a hard disk drive in the storage unit) or the storage adapter that is attached to the storage unit. The failing server might be part of a cluster if any of the following conditions is true:
 - You have identified the failing server as part of a cluster (two or more servers sharing external storage devices).
 - One or more external storage units are attached to the failing server and at least one of the attached storage units is also attached to another server or unidentifiable device.
 - One or more servers are located near the failing server.

Important: If the server is part of a shared hard disk drive cluster, run one test at a time. Do not run any suite of tests, such as “quick” or “normal” tests, because this might enable the hard disk drive diagnostic tests.

- If the server is halted and a POST error code is displayed, see “Error logs” on page 20. If the server is halted and no error message is displayed, see “Troubleshooting tables” on page 30 and “Solving undetermined problems” on page 60.
- For information about power-supply problems, see “Solving power problems” on page 58.
- For intermittent problems, check the error log; see “Error logs” on page 20 and “Diagnostic programs, messages, and error codes” on page 45.

Performing the checkout procedure

To perform the checkout procedure, complete the following steps:

1. Is the server part of a cluster?

- **No:** Go to step 2.
 - **Yes:** Shut down all failing servers that are related to the cluster. Go to step 2.
2. Complete the following steps:
 - a. Turn off the server and all external devices.
 - b. Check all cables and power cords.
 - c. Set all display controls to the middle positions.
 - d. Turn on all external devices.
 - e. Turn on the server. If the server does not start, see “Troubleshooting tables” on page 30.
 - f. Check the system-error LED on the operator information panel. If it is flashing, check the error LEDs (see “System board error LEDs and the light path button” on page 42).
 - g. Check for the following results:
 - Successful completion of POST (see “POST” on page 15 for more information)
 - Successful completion of startup
 3. Did one or more beeps sound?
 - **No:** Find the failure symptom in “Troubleshooting tables” on page 30; if necessary, run the diagnostic programs (see “Running the diagnostic programs” on page 45).
 - If you receive an error, see “Diagnostic error codes” on page 47.
 - If the diagnostic programs were completed successfully and you still suspect a problem, see “Solving undetermined problems” on page 60.
 - **Yes:** Find the beep code in “POST beep codes” on page 15; if necessary, see “Solving undetermined problems” on page 60.

Troubleshooting tables

Use the troubleshooting tables to find solutions to problems that have identifiable symptoms.

If you cannot find a problem in these tables, see “Running the diagnostic programs” on page 45 for information about testing the server.

If you have just added new software or a new optional device and the server is not working, complete the following steps before you use the troubleshooting tables:

1. Check the system-error LED on the operator information panel; if it is lit, check the system board error LEDs (see “System board error LEDs and the light path button” on page 42).
2. Remove the software or device that you just added.
3. Run the diagnostic tests to determine whether the server is running correctly (see “Running the diagnostic programs” on page 45).
4. Reinstall the new software or new device.

CD or DVD drive problems

- Follow the suggested actions in the order in which they are listed in the Action column until the problem is solved.
- See Chapter 3, “Parts listing, Type 7984 and 7986 servers,” on page 63 to determine which components are customer replaceable units (CRU) and which components are field replaceable units (FRU).
- If an action step is preceded by “(Trained service technician only),” that step must be performed only by a trained service technician.

Symptom	Action
The CD or DVD drive is not recognized.	<ol style="list-style-type: none">1. Make sure that:<ul style="list-style-type: none">• The IDE channel to which the CD or DVD drive is attached (primary) is enabled in the Configuration/Setup Utility program.• All cables and jumpers are installed correctly.• The correct device driver is installed for the CD or DVD drive.2. Run the CD or DVD drive diagnostic programs (see “Running the diagnostic programs” on page 45).3. Reseat the following components:<ol style="list-style-type: none">a. CD or DVD driveb. CD or DVD drive cable4. Replace the following components one at a time, in the order shown, restarting the server each time:<ol style="list-style-type: none">a. CD or DVD driveb. CD or DVD drive cablec. CD or DVD drive backplaned. (Trained service technician only) System board

<ul style="list-style-type: none"> • Follow the suggested actions in the order in which they are listed in the Action column until the problem is solved. • See Chapter 3, “Parts listing, Type 7984 and 7986 servers,” on page 63 to determine which components are customer replaceable units (CRU) and which components are field replaceable units (FRU). • If an action step is preceded by “(Trained service technician only),” that step must be performed only by a trained service technician. 	
Symptom	Action
The CD or DVD is not working correctly.	<ol style="list-style-type: none"> 1. Clean the CD or DVD drive. 2. Run the CD or DVD drive diagnostic programs (see “Running the diagnostic programs” on page 45). 3. Reseat the following components one at a time, in the order shown, restarting the server each time: <ol style="list-style-type: none"> a. CD or DVD drive b. CD or DVD drive cable 4. Replace the following components one at a time, in the order shown, restarting the server each time: <ol style="list-style-type: none"> a. CD or DVD drive b. CD or DVD drive cable c. CD or DVD drive backplane d. (Trained service technician only) System board
The CD or DVD drive tray is not working.	<ol style="list-style-type: none"> 1. Make sure that the server is turned on. 2. Insert the end of a straightened paper clip into the manual tray-release opening. 3. Reseat the CD or DVD drive cable. 4. Replace the CD or DVD drive.

General problems

<ul style="list-style-type: none"> • Follow the suggested actions in the order in which they are listed in the Action column until the problem is solved. • See Chapter 3, “Parts listing, Type 7984 and 7986 servers,” on page 63 to determine which components are customer replaceable units (CRU) and which components are field replaceable units (FRU). • If an action step is preceded by “(Trained service technician only),” that step must be performed only by a trained service technician. 	
Symptom	Action
An LED is not working, or a similar problem has occurred.	If the part is a CRU, replace it. If the part is a FRU, the part must be replaced by a trained service technician.

Hard disk drive problems

<ul style="list-style-type: none"> • Follow the suggested actions in the order in which they are listed in the Action column until the problem is solved. • See Chapter 3, “Parts listing, Type 7984 and 7986 servers,” on page 63 to determine which components are customer replaceable units (CRU) and which components are field replaceable units (FRU). • If an action step is preceded by “(Trained service technician only),” that step must be performed only by a trained service technician. 	
Symptom	Action
Not all drives are recognized by the hard disk drive diagnostic test.	<ol style="list-style-type: none"> 1. Reseat the hard disk drive signal cable at both ends; then, run the hard disk drive diagnostic test again. 2. Remove the drive that is indicated by the diagnostic tests; then, run the hard disk drive diagnostic test again. If the remaining drives are recognized, replace the drive that you removed with a new one.
The server stops responding during the hard disk drive diagnostic test.	<ol style="list-style-type: none"> 1. Reseat the hard disk drive signal cable at both ends; then, run the hard disk drive diagnostic test again. 2. Remove the hard disk drive that was being tested when the server stopped responding; then, run the diagnostic test again. If the hard disk drive diagnostic test runs successfully, replace the drive that you removed with a new one.
A hard disk drive was not detected while the operating system was being started.	Reseat all hard disk drive cables; then, run the hard disk drive diagnostic tests again.
A hard disk drive that you are installing does not fit correctly in the cage.	Make sure that the type of drive is correct for this server (see Chapter 3, “Parts listing, Type 7984 and 7986 servers,” on page 63).

Intermittent problems

<ul style="list-style-type: none"> • Follow the suggested actions in the order in which they are listed in the Action column until the problem is solved. • See Chapter 3, “Parts listing, Type 7984 and 7986 servers,” on page 63 to determine which components are customer replaceable units (CRU) and which components are field replaceable units (FRU). • If an action step is preceded by “(Trained service technician only),” that step must be performed only by a trained service technician. 	
Symptom	Action
A problem occurs only occasionally and is difficult to diagnose.	<ol style="list-style-type: none"> 1. Make sure that: <ul style="list-style-type: none"> • All cables and cords are connected securely to the rear of the server and attached devices. • There is adequate cooling airflow. Reduced airflow due to a failed fan or an internal or external obstruction can cause the server to overheat and shut down. 2. Check the BMC log (see “Error logs” on page 20).

<ul style="list-style-type: none"> • Follow the suggested actions in the order in which they are listed in the Action column until the problem is solved. • See Chapter 3, “Parts listing, Type 7984 and 7986 servers,” on page 63 to determine which components are customer replaceable units (CRU) and which components are field replaceable units (FRU). • If an action step is preceded by “(Trained service technician only),” that step must be performed only by a trained service technician. 	
Symptom	Action
The server resets (restarts) occasionally.	<ol style="list-style-type: none"> 1. If the reset occurs during POST and the POST watchdog timer is enabled (click Advanced Setup --> Baseboard Management Controller (BMC) Settings --> BMC Post Watchdog in the Configuration/Setup Utility program to see the POST watchdog setting), make sure that sufficient time is allowed in the watchdog timeout value (BMC POST Watchdog Timeout). See the <i>User's Guide</i> for information about the settings in the Configuration/Setup Utility program. If the server continues to reset during POST, see “POST” on page 15 and “Diagnostic programs, messages, and error codes” on page 45. 2. If the reset occurs after the operating system starts, disable any automatic server restart (ASR) utilities, such as the IBM Automatic Server Restart IPMI Application for Windows, or ASR devices that might be installed. Note: ASR utilities operate as operating-system utilities and are related to the IPMI device driver. If the reset continues to occur after the operating system starts, the operating system might have a problem; see “Software problems” on page 41. 3. If neither condition applies, check the BMC log (see “Error logs” on page 20).

USB keyboard, mouse, or pointing-device problems

<ul style="list-style-type: none"> • Follow the suggested actions in the order in which they are listed in the Action column until the problem is solved. • See Chapter 3, “Parts listing, Type 7984 and 7986 servers,” on page 63 to determine which components are customer replaceable units (CRU) and which components are field replaceable units (FRU). • If an action step is preceded by “(Trained service technician only),” that step must be performed only by a trained service technician. 	
Symptom	Action
All or some keys on the keyboard do not work.	<ol style="list-style-type: none"> 1. Make sure that: <ul style="list-style-type: none"> • The keyboard cable is securely connected. • The server and the monitor are turned on. 2. Reseat the keyboard cable. 3. If you are using an external USB hub, disconnect the keyboard from the hub and connect it directly to the server. 4. Replace the following components one at a time, in the order shown, restarting the server each time: <ol style="list-style-type: none"> a. Keyboard b. (Trained service technician only) System board

<ul style="list-style-type: none"> • Follow the suggested actions in the order in which they are listed in the Action column until the problem is solved. • See Chapter 3, “Parts listing, Type 7984 and 7986 servers,” on page 63 to determine which components are customer replaceable units (CRU) and which components are field replaceable units (FRU). • If an action step is preceded by “(Trained service technician only),” that step must be performed only by a trained service technician. 	
Symptom	Action
The USB mouse or USB pointing device does not work.	<ol style="list-style-type: none"> 1. Make sure that: <ul style="list-style-type: none"> • The mouse or pointing-device USB cable is securely connected to the server, and the keyboard and the device drivers are installed correctly. • The server and the monitor are turned on. 2. Reseat the mouse or pointing-device cable. 3. If you are using an external USB hub, disconnect the mouse or pointing device from the hub and connect it directly to the server. 4. Replace the following components one at a time, in the order shown, restarting the server each time: <ol style="list-style-type: none"> a. Mouse or pointing device b. (Trained service technician only) System board

Memory problems

<ul style="list-style-type: none"> • Follow the suggested actions in the order in which they are listed in the Action column until the problem is solved. • See Chapter 3, “Parts listing, Type 7984 and 7986 servers,” on page 63 to determine which components are customer replaceable units (CRU) and which components are field replaceable units (FRU). • If an action step is preceded by “(Trained service technician only),” that step must be performed only by a trained service technician. 	
Symptom	Action
The amount of system memory that is displayed is less than the amount of installed physical memory.	<ol style="list-style-type: none"> 1. Make sure that: <ul style="list-style-type: none"> • No error LED is lit on the operator information panel. • If memory sparing is enabled, the installed DIMMs are configured correctly. (For information about the types of dual inline memory modules (DIMMs) that the server supports and other information that you must consider when installing DIMMs, see the <i>User’s Guide</i> on the IBM Documentation CD.) • The DIMMs are seated correctly. • You have installed the correct type of memory. See “Installing a memory module” on page 81. • If the server uses only one microprocessor, no DIMMs are installed in positions 7 through 12. 2. Run memory diagnostics (see “Running the diagnostic programs” on page 45). 3. Replace the following components one at a time, in the order shown, restarting the server each time: <ol style="list-style-type: none"> a. DIMMs b. (Trained service technician only) System board
Multiple rows of DIMMs in a branch are identified as failing.	<ol style="list-style-type: none"> 1. Reseat the DIMMs; then, restart the server. 2. Replace the lowest-numbered DIMM pair of those identified; then, restart the server. Repeat as necessary. 3. (Trained service technician only) Replace the system board.

Microprocessor problems

- Follow the suggested actions in the order in which they are listed in the Action column until the problem is solved.
- See Chapter 3, “Parts listing, Type 7984 and 7986 servers,” on page 63 to determine which components are customer replaceable units (CRU) and which components are field replaceable units (FRU).
- If an action step is preceded by “(Trained service technician only),” that step must be performed only by a trained service technician.

Symptom	Action
The server emits a continuous beep during POST, indicating that the startup (boot) microprocessor is not working correctly.	<ol style="list-style-type: none">1. Correct any errors that are indicated by the error LEDs (see “System board error LEDs and the light path button” on page 42).2. Make sure that the server supports the microprocessor. See Chapter 3, “Parts listing, Type 7984 and 7986 servers,” on page 63 for a list of supported microprocessors.3. (Trained service technician only) Make sure that the microprocessor is seated correctly.4. (Trained service technician only) Replace the microprocessor.5. (Trained service technician only) Replace the system board.

Monitor or video problems

Some IBM monitors have their own self-tests. If you suspect a problem with your monitor, see the documentation that comes with the monitor for instructions for testing and adjusting the monitor. If you cannot diagnose the problem, call for service.

<ul style="list-style-type: none"> • Follow the suggested actions in the order in which they are listed in the Action column until the problem is solved. • See Chapter 3, “Parts listing, Type 7984 and 7986 servers,” on page 63 to determine which components are customer replaceable units (CRU) and which components are field replaceable units (FRU). • If an action step is preceded by “(Trained service technician only),” that step must be performed only by a trained service technician. 	
Symptom	Action
Testing the monitor.	<ol style="list-style-type: none"> 1. Make sure that the monitor cables are firmly connected. 2. Try using a different monitor on the server, or try testing the monitor on a different server. 3. If you are using a USB-connected monitor with an external USB hub, disconnect the monitor from the hub and connect it directly to the server. 4. Run the diagnostic programs (see “Running the diagnostic programs” on page 45). If the monitor passes the diagnostic programs, the problem might be a video device driver. 5. (Trained service technician only) Replace the system board
The screen is blank.	<ol style="list-style-type: none"> 1. If you are using a USB-connected monitor with an external USB hub, disconnect the monitor from the hub and connect it directly to the server. 2. Make sure that: <ul style="list-style-type: none"> • The server is turned on. If there is no power to the server, see “Power problems” on page 39. • The monitor cables are connected correctly. • The monitor is turned on and the brightness and contrast controls are adjusted correctly. • No beep codes sound when the server is turned on. 3. Make sure that the correct server is controlling the monitor, if applicable. 4. Make sure that damaged BIOS code is not affecting the video; see “Updating the firmware” on page 109. 5. See “Solving undetermined problems” on page 60.
The monitor works when you turn on the server, but the screen goes blank when you start some application programs.	<ol style="list-style-type: none"> 1. Make sure that: <ul style="list-style-type: none"> • The application program is not setting a display mode that is higher than the capability of the monitor. • You installed the necessary device drivers for the application. 2. Run video diagnostics (see “Running the diagnostic programs” on page 45). <ul style="list-style-type: none"> • If the server passes the video diagnostics, the video is good; see “Solving undetermined problems” on page 60. • (Trained service technician only) If the server fails the video diagnostics, replace the system board.

- Follow the suggested actions in the order in which they are listed in the Action column until the problem is solved.
- See Chapter 3, “Parts listing, Type 7984 and 7986 servers,” on page 63 to determine which components are customer replaceable units (CRU) and which components are field replaceable units (FRU).
- If an action step is preceded by “(Trained service technician only),” that step must be performed only by a trained service technician.

Symptom	Action
The monitor has screen jitter, or the screen image is wavy, unreadable, rolling, or distorted.	<ol style="list-style-type: none"> 1. If the monitor self-tests show that the monitor is working correctly, consider the location of the monitor. Magnetic fields around other devices (such as transformers, appliances, fluorescent lights, and other monitors) can cause screen jitter or wavy, unreadable, rolling, or distorted screen images. If this happens, turn off the monitor. Attention: Moving a color monitor while it is turned on might cause screen discoloration. Move the device and the monitor at least 305 mm (12 in.) apart, and turn on the monitor. Notes: <ol style="list-style-type: none"> a. To prevent diskette drive read/write errors, make sure that the distance between the monitor and any external diskette drive is at least 76 mm (3 in.). b. Non-IBM monitor cables might cause unpredictable problems. 2. Reseat the monitor cable. 3. Replace the following components one at a time, in the order shown, restarting the server each time: <ol style="list-style-type: none"> a. Monitor cable b. Monitor c. (Trained service technician only) System board
Wrong characters appear on the screen.	<ol style="list-style-type: none"> 1. If the wrong language is displayed, update the BIOS code (see “Updating the firmware” on page 109) with the correct language. 2. Reseat the monitor cable. 3. Replace the following components one at a time, in the order shown, restarting the server each time: <ol style="list-style-type: none"> a. Monitor b. (Trained service technician only) System board

Optional-device problems

- Follow the suggested actions in the order in which they are listed in the Action column until the problem is solved.
- See Chapter 3, “Parts listing, Type 7984 and 7986 servers,” on page 63 to determine which components are customer replaceable units (CRU) and which components are field replaceable units (FRU).
- If an action step is preceded by “(Trained service technician only),” that step must be performed only by a trained service technician.

Symptom	Action
An IBM optional device that was just installed does not work.	<ol style="list-style-type: none"> 1. Make sure that: <ul style="list-style-type: none"> • The device is designed for the server (see http://www.ibm.com/servers/eserver/serverproven/compat/us/). • You followed the installation instructions that came with the device and the device is installed correctly. • You have not loosened any other installed devices or cables. • You updated the configuration information in the Configuration/Setup Utility program. Whenever memory or any other device is changed, you must update the configuration. 2. Reseat the device that you just installed. 3. Replace the device that you just installed.
An IBM optional device that worked previously does not work now.	<ol style="list-style-type: none"> 1. Make sure that all of the hardware and cable connections for the device are secure. 2. If the device comes with test instructions, use those instructions to test the device. 3. Reseat the failing device. 4. Replace the failing device.

Power problems

<ul style="list-style-type: none"> • Follow the suggested actions in the order in which they are listed in the Action column until the problem is solved. • See Chapter 3, “Parts listing, Type 7984 and 7986 servers,” on page 63 to determine which components are customer replaceable units (CRU) and which components are field replaceable units (FRU). • If an action step is preceded by “(Trained service technician only),” that step must be performed only by a trained service technician. 	
Symptom	Action
<p>The power-control button does not work.</p> <p>Note: The power-control button will not function until 20 seconds after the server has been connected to ac power.</p>	<ol style="list-style-type: none"> 1. Make sure that the power-control button is working correctly: <ol style="list-style-type: none"> a. Disconnect the server power cord. b. Reconnect the power cord. c. Press the power-control button. d. If the server does not start: <ul style="list-style-type: none"> • Disconnect the server power cord and reseal the operator information panel cables; then, repeat steps 1a through 1c. • If the problem remains, replace the operator information panel. 2. Make sure that: <ul style="list-style-type: none"> • The power cord is correctly connected to the server and to a working electrical outlet. • (Trained service technician only) The microprocessor is correctly installed. 3. If you just installed an optional device, remove it, and restart the server. If the server now turns on, you might have installed more devices than the power supply supports. 4. Replace the following components one at a time, in the order shown, restarting the server each time: <ol style="list-style-type: none"> a. Power supply. b. (Trained service technician only) system board. 5. See “Solving undetermined problems” on page 60.
<p>The server does not turn off.</p>	<ol style="list-style-type: none"> 1. Determine whether you are using an Advanced Configuration and Power Interface (ACPI) or a non-ACPI operating system. If you are using a non-ACPI operating system, complete the following steps: <ol style="list-style-type: none"> a. Press Ctrl+Alt+Delete. b. Turn off the server by pressing the power-control button for 5 seconds. c. Restart the server. d. If the server fails POST and the power-control button does not work, disconnect the ac power cord for 20 seconds; then, reconnect the ac power cord and restart the server.
<p>The server unexpectedly shuts down, and the LEDs on the operator information panel are not lit.</p>	<p>See “Solving undetermined problems” on page 60.</p>

Serial port problems

<ul style="list-style-type: none"> • Follow the suggested actions in the order in which they are listed in the Action column until the problem is solved. • See Chapter 3, “Parts listing, Type 7984 and 7986 servers,” on page 63 to determine which components are customer replaceable units (CRU) and which components are field replaceable units (FRU). • If an action step is preceded by “(Trained service technician only),” that step must be performed only by a trained service technician. 	
Symptom	Action
The number of serial ports that are identified by the operating system is less than the number of installed serial ports.	<ol style="list-style-type: none"> 1. Make sure that: <ul style="list-style-type: none"> • Each port is assigned a unique address in the Configuration/Setup Utility program and none of the serial ports is disabled. • The serial-port adapter (if one is present) is seated correctly. 2. Replace the serial port adapter.
A serial device does not work.	<ol style="list-style-type: none"> 1. Make sure that: <ul style="list-style-type: none"> • The device is compatible with the server. • The serial port is enabled and is assigned a unique address. • The device is connected to the correct connector (see “Internal LEDs, connectors, and jumpers” on page 7). 2. Reseat the following components: <ol style="list-style-type: none"> a. Failing serial device b. Serial cable 3. Replace the following components one at a time, in the order shown, restarting the server each time: <ol style="list-style-type: none"> a. Failing serial device b. Serial cable c. (Trained service technician only) System board

ServerGuide problems

<ul style="list-style-type: none"> • Follow the suggested actions in the order in which they are listed in the Action column until the problem is solved. • See Chapter 3, “Parts listing, Type 7984 and 7986 servers,” on page 63 to determine which components are customer replaceable units (CRU) and which components are field replaceable units (FRU). • If an action step is preceded by “(Trained service technician only),” that step must be performed only by a trained service technician. 	
Symptom	Action
The <i>ServerGuide™ Setup and Installation</i> CD will not start.	<ol style="list-style-type: none"> 1. Make sure that the server supports the ServerGuide program and has a startable (bootable) CD or DVD drive. 2. If the startup (boot) sequence settings have been changed, make sure that the CD or DVD drive is first in the startup sequence. 3. If more than one CD or DVD drive is installed, make sure that only one drive is set as the primary drive. Start the CD from the primary drive.
The operating-system installation program continuously loops.	Make more space available on the hard disk.
The ServerGuide program will not start the operating-system CD.	Make sure that the operating-system CD is supported by the ServerGuide program. See the <i>ServerGuide Setup and Installation</i> CD label for a list of supported operating-system versions.

<ul style="list-style-type: none"> • Follow the suggested actions in the order in which they are listed in the Action column until the problem is solved. • See Chapter 3, “Parts listing, Type 7984 and 7986 servers,” on page 63 to determine which components are customer replaceable units (CRU) and which components are field replaceable units (FRU). • If an action step is preceded by “(Trained service technician only),” that step must be performed only by a trained service technician. 	
Symptom	Action
The operating system cannot be installed; the option is not available.	Make sure that the server supports the operating system. Run the ServerGuide program and make sure that setup is complete.

Software problems

<ul style="list-style-type: none"> • Follow the suggested actions in the order in which they are listed in the Action column until the problem is solved. • See Chapter 3, “Parts listing, Type 7984 and 7986 servers,” on page 63 to determine which components are customer replaceable units (CRU) and which components are field replaceable units (FRU). • If an action step is preceded by “(Trained service technician only),” that step must be performed only by a trained service technician. 	
Symptom	Action
You suspect a software problem.	<ol style="list-style-type: none"> 1. To determine whether the problem is caused by the software, make sure that: <ul style="list-style-type: none"> • The server has the minimum memory that is needed to use the software. For memory requirements, see the information that comes with the software. If you have just installed an adapter or memory, the server might have a memory-address conflict. • The software is designed to operate on the server. • Other software works on the server. • The software works on another server. 2. If you receive any error messages while you use the software, see the information that comes with the software for a description of the messages and suggested solutions to the problem. 3. Contact your place of purchase of the software.

Universal Serial Bus (USB) device problems

<ul style="list-style-type: none"> • Follow the suggested actions in the order in which they are listed in the Action column until the problem is solved. • See Chapter 3, “Parts listing, Type 7984 and 7986 servers,” on page 63 to determine which components are customer replaceable units (CRU) and which components are field replaceable units (FRU). • If an action step is preceded by “(Trained service technician only),” that step must be performed only by a trained service technician. 	
Symptom	Action
A USB device does not work.	<ol style="list-style-type: none"> 1. Make sure that: <ul style="list-style-type: none"> • The correct USB device driver is installed. • The operating system supports USB devices. 2. Make sure that the USB configuration options are set correctly in the Configuration/Setup Utility program (see the <i>User's Guide</i> on the IBM System x Documentation CD for more information). 3. If you are using an external USB hub, disconnect the USB device from the hub and connect it directly to the server.

System board error LEDs and the light path button

The system-error LED on the front panel (“Front view” on page 5) is lit to indicate that a system error has occurred. The system board has error LEDs for microprocessors, fans, and memory that will help to locate the source of the error. Run the diagnostic programs (“Running the diagnostic programs” on page 45) to find the cause of the error.

When the system board error LEDs are lit to indicate an error, they remain lit when the server is turned off, provided that the server is still connected to power and the power supply is operating correctly.

Before you work inside the server to view error LEDs, read the safety information that begins on page vii and “Handling static-sensitive devices” on page 70.

Remove the server cover and look inside the server for lit LEDs (“Removing the cover” on page 71). If the server is not connected to ac power, press the light path button. A lit LED on or beside a component identifies the component that is causing the error.

The following illustration shows the LEDs on the system board.

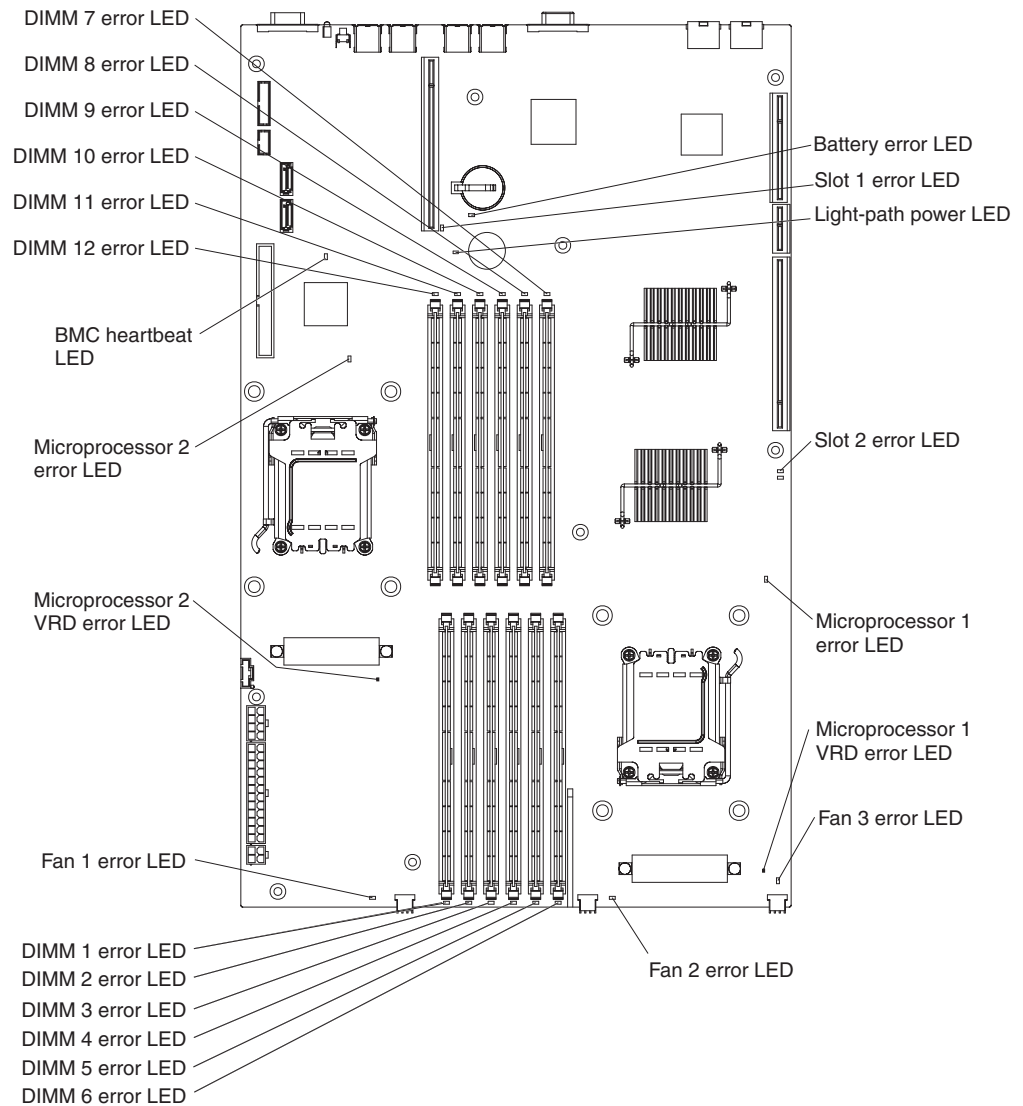

Light path button

The light path button allows you to review error indications after ac power has been removed from the server. Press and hold the button, which is behind the operator information panel, to relight the error LEDs that were lit before you removed power from the server. The LEDs will remain lit for as long as you press the button, to a maximum of 30 seconds.

Power-supply LEDs

The following minimum configuration is required for the DC LED on the power supply to be lit:

- Power supply
- Power cord

The following minimum configuration is required for the server to start:

- One microprocessor in microprocessor socket 1
- Two 512 MB DIMMs on the system board
- Power supply

- Power cord
- Three cooling fans

The following illustration shows the locations of the power-supply LEDs.

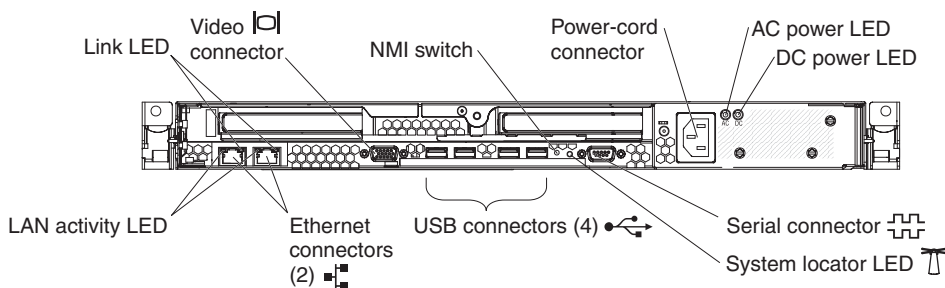

The following table describes the problems that are indicated by various combinations of the power-supply LEDs and the power-on LED on the operator information panel and suggested actions to correct the detected problems.

- Follow the suggested actions in the order in which they are listed in the Action column until the problem is solved.
- See Chapter 3, “Parts listing, Type 7984 and 7986 servers,” on page 63 to determine which components are customer replaceable units (CRU) and which components are field replaceable units (FRU).
- If an action step is preceded by “(Trained service technician only),” that step must be performed only by a trained service technician.

Power-supply LEDs		Operator information panel power-on LED	Description	Action
AC	DC			
Off	Off	Off	No power to the server, or a problem with the ac power source.	<ol style="list-style-type: none"> 1. Check the ac power to the server. 2. Make sure that the ac power cord is connected to a functioning power source.
Lit	Off	Off	DC source power problem.	<ol style="list-style-type: none"> 1. View the BMC system event log (see “Error logs” on page 20). 2. Replace the power supply (see “Removing the power supply” on page 87). 3. (Trained service technician only) Replace the system board (see “Removing the system board” on page 105).
Lit	Lit	Off	Standby power problem.	<ol style="list-style-type: none"> 1. Reseat the operator information panel signal cable. 2. Replace the operator information panel signal cable. 3. Replace the operator information panel (see “Removing the operator information panel” on page 90). 4. (Trained service technician only) Replace the system board (see “Removing the system board” on page 105).
Lit	Lit	Flashing	The power is good.	The server is not powered on. No action is necessary.
Lit	Lit	Lit	The power is good.	The server is powered on. No action is necessary.

Diagnostic programs, messages, and error codes

The diagnostic programs are the primary method of testing the major components of the server. As you run the diagnostic programs, text messages and error codes are displayed on the screen and are saved in the test log. A diagnostic text message or error code indicates that a problem has been detected; to determine what action you should take as a result of a message or error code, see the table in “Diagnostic error codes” on page 47.

Running the diagnostic programs

To run the diagnostic programs, complete the following steps:

1. If the server is running, turn off the server and all attached devices.
2. Turn on all attached devices; then, turn on the server.
3. When the prompt **Press F1 For Configuration/Setup** is displayed, press F1.
4. From the Configuration/Setup Utility menu, select **Start Options**.
5. From the **Start Options** menu, select **Startup Sequence Options**.
6. Note the device that is selected as the first startup device. Later, you must restore this setting.
7. Select **CD/DVD-ROM** as the first startup device.
8. Press Esc two times to return to the Configuration/Setup Utility menu.
9. Insert the *IBM Enhanced Diagnostics* CD in the CD drive.
10. Select **Save & Exit Setup** and follow the prompts. The diagnostic program starts.
11. From the top of the screen, select either **Extended** or **Basic**.
12. From the diagnostic programs screen, select the test that you want to run, and follow the instructions on the screen.

For help with the diagnostic programs, press F1. You also can press F1 from within a help screen to obtain online documentation from which you can select different categories. To exit from the help information, press Esc.

To determine what action you should take as a result of a diagnostic text message or error code, see the table in “Diagnostic error codes” on page 47.

If the diagnostic programs do not detect any hardware errors but the problem remains during normal server operations, a software error might be the cause. If you suspect a software problem, see the information that comes with your software.

A single problem might cause more than one error message. When this happens, correct the cause of the first error message. The other error messages usually will not occur the next time you run the diagnostic programs.

Exception: If there are multiple error codes or light path diagnostics LEDs that indicate a microprocessor error, the error might be in a microprocessor or in a microprocessor socket. See “Microprocessor problems” on page 35 for information about diagnosing microprocessor problems.

If the server stops during testing and you cannot continue, restart the server and try to run the diagnostic programs again. If the problem remains, replace the component that was being tested when the server stopped.

The keyboard and mouse (pointing device) tests assume that a keyboard and mouse are attached to the server. If no mouse or a USB mouse is attached to the server, you cannot use the **Next Cat** and **Prev Cat** buttons to select categories. All other mouse-selectable functions are available through function keys. You can use the regular keyboard test to test a USB keyboard, and you can use the regular mouse test to test a USB mouse. You can run the USB interface test only if no USB devices are attached. The USB test will not run if a Remote Supervisor Adapter II SlimLine is installed.

To view server configuration information (such as system configuration, memory contents, interrupt request (IRQ) use, direct memory access (DMA) use, device drivers, and so on), select **Hardware Info** from the top of the screen.

Diagnostic text messages

Diagnostic text messages are displayed while the tests are running. A diagnostic text message contains one of the following results:

Passed: The test was completed without any errors.

Failed: The test detected an error.

User Aborted: You stopped the test before it was completed.

Not Applicable: You attempted to test a device that is not installed in the server.

Aborted: The test could not proceed because of the server configuration.

Warning: The test could not be run. There was no failure of the hardware that was being tested, but there might be a hardware failure elsewhere, or another problem prevented the test from running; for example, there might be a configuration problem, or the hardware might be missing or is not being recognized.

The result is followed by an error code or other additional information about the error.

Viewing the test log

To view the test log when the tests are completed, select **Utility** from the top of the screen and then select **View Test Log**. The summary test log is displayed. To view the detailed test log, press the Tab key while viewing the summary log.

The test-log data is maintained only while you are running the diagnostic programs. When you exit from the diagnostic programs, the test log is cleared.

To save the test log to a file on a diskette or to the hard disk, click **Save Log** on the diagnostic programs screen and specify a location and name for the saved log file.

Notes:

1. To create and use a diskette, you must add an optional external USB diskette drive to the server before you turn the server on.
2. To save the test log to a diskette, you must use a diskette that you have formatted yourself; this function does not work with preformatted diskettes. If the diskette has sufficient space for the test log, the diskette can contain other data.

Diagnostic error codes

The following table describes the error codes that the diagnostic programs might generate and suggested actions to correct the detected problems.

If the diagnostic programs generate error codes that are not listed in the table, make sure that the latest level of BIOS code is installed (see “Updating the firmware” on page 109).

In the error codes, x can be any numeral or letter. However, if the three-digit number in the central position of the code is 000, 195, or 197, *do not* replace a CRU or FRU. When these numbers are in the central position of the code, they have the following meanings:

- 000** The server passed the test. Do not replace a CRU or FRU.
- 195** The Esc key was pressed to end the test. Do not replace a CRU or FRU.
- 197** This is a warning error, but it does not indicate a hardware failure; do not replace a CRU or FRU. Take the action that is indicated in the Action column but *do not replace a CRU or a FRU*. See the description of **Warning** in “Diagnostic text messages” on page 46 for more information.

<ul style="list-style-type: none"> • Follow the suggested actions in the order in which they are listed in the Action column until the problem is solved. • See Chapter 3, “Parts listing, Type 7984 and 7986 servers,” on page 63 to determine which components are customer replaceable units (CRU) and which components are field replaceable units (FRU). • If an action step is preceded by “(Trained service technician only),” that step must be performed only by a trained service technician. 		
Error code	Description	Action
000-197-000 000-198-000	Test aborted	<ol style="list-style-type: none"> 1. Check the test log for messages that indicate the cause of the error, and take the indicated action. 2. Reinstall and, if necessary, update the BIOS code on the server; then, rerun the test (see “Updating the firmware” on page 109).
001-250-00n	ECC test logic failed. See PC Doctor logs. Note: n = Failing CPU. (1-4)	<ol style="list-style-type: none"> 1. Restart the server. 2. Run the diagnostic test again. 3. (Trained service technician only) Replace the failing microprocessor. 4. (Trained service technician only) Replace the system board.
001-xxx-000	Failed core test.	(Trained service technician only) Replace the system board.
001-xxx-001	Failed core test.	(Trained service technician only) Replace the system board.
005-xxx-000	Failed video test.	(Trained service technician only) Replace the system board.
011-xxx-000	Failed COM1 serial port test.	<ol style="list-style-type: none"> 1. Check the loopback plug that is connected to the serial port (if installed). 2. (Trained service technician only) Replace the system board.
015-xxx-001	USB interface not found, board damaged.	(Trained service technician only) Replace the system board.

- Follow the suggested actions in the order in which they are listed in the Action column until the problem is solved.
- See Chapter 3, “Parts listing, Type 7984 and 7986 servers,” on page 63 to determine which components are customer replaceable units (CRU) and which components are field replaceable units (FRU).
- If an action step is preceded by “(Trained service technician only),” that step must be performed only by a trained service technician.

Error code	Description	Action
015-xxx-198	USB device connected during test.	<ol style="list-style-type: none"> 1. Disconnect all USB devices and run the test again. 2. (Trained service technician only) Replace the system board.
020-xxx-000	Failed PCI Express interface test.	(Trained service technician only) Replace the system board.
089-xxx-00 <i>n</i>	Failed microprocessor test. <i>n</i> = number of failing microprocessor	<ol style="list-style-type: none"> 1. Reinstall and, if necessary, update the BIOS code on the server (see “Updating the firmware” on page 109); then, run the test again. 2. Trained service technician only: <ol style="list-style-type: none"> a. Reseat microprocessor <i>n</i>. b. Replace microprocessor <i>n</i>. c. Replace the system board.
201-198-xxx	Memory test aborted.	<ol style="list-style-type: none"> 1. Restart the server. 2. Run the diagnostic test again. 3. See the error log for additional information.
201-199-xxx	Unexpected error. Test aborted.	<ol style="list-style-type: none"> 1. Restart the server. 2. Run the diagnostic test again. 3. Refer to the error log for additional information.
201-xxx-PBD	Multiple DIMM failure. <ul style="list-style-type: none"> • P = CPU Number [1 - 4]. • B = Failing Bank/Pair number. • D = Failing DIMM number within failing CPU # P. • D = 9 = Both DIMMs in the failing bank/pair of DIMMs. 	<ol style="list-style-type: none"> 1. Reseat the failing DIMM(s); then, run the memory diagnostic test again. 2. Replace the failing DIMM(s); then, run the memory diagnostic test again. 3. (Trained service technician only) Replace the system board.
206-xxx-000	Failed diskette drive test.	<ol style="list-style-type: none"> 1. Rerun the test using another diskette. 2. Reseat the diskette drive cable in the connector. 3. If you are using an external USB hub, disconnect the diskette drive from the hub and connect it directly to the server. 4. Replace the following components one at a time, in the order shown, restarting the server each time: <ol style="list-style-type: none"> a. Diskette drive. b. (Trained service technician only) System board

- Follow the suggested actions in the order in which they are listed in the Action column until the problem is solved.
- See Chapter 3, “Parts listing, Type 7984 and 7986 servers,” on page 63 to determine which components are customer replaceable units (CRU) and which components are field replaceable units (FRU).
- If an action step is preceded by “(Trained service technician only),” that step must be performed only by a trained service technician.

Error code	Description	Action
215-xxx-000	Failed CD or DVD test.	<ol style="list-style-type: none"> 1. Run the test again with a different CD or DVD. 2. Reseat the following components: <ol style="list-style-type: none"> a. CD or DVD drive b. CD or DVD drive cables 3. Replace the following components one at a time, in the order shown, restarting the server each time: <ol style="list-style-type: none"> a. CD or DVD drive cables b. CD or DVD drive c. (Trained service technician only) System board.
217-198-xxx	Could not establish drive parameters.	<ol style="list-style-type: none"> 1. Reseat the hard disk drive cables. 2. Replace the following components in the order shown, restarting the server each time: <ol style="list-style-type: none"> a. Hard disk drive cable b. Hard disk drive
217-xxx-000	Failed fixed disk test.	<ol style="list-style-type: none"> 1. Reseat the hard disk drive 1 cables. 2. Replace hard disk drive 1. 3. (Trained service technician only) Replace the system board
217-xxx-001	Failed fixed disk test.	<ol style="list-style-type: none"> 1. Reseat the hard disk drive 2 cables. 2. Replace hard disk drive 2. 3. (Trained service technician only) Replace the system board
301-xxx-000	Failed keyboard test.	<ol style="list-style-type: none"> 1. Run the Configuration/Setup Utility program and enable keyboardless operation to prevent the POST error message 301 from being displayed during startup. 2. Reseat the keyboard cable in the connector. 3. If you are using an external USB hub, disconnect the keyboard from the hub and connect it directly to the server. 4. Replace the following components one at a time, in the order shown, restarting the server each time: <ol style="list-style-type: none"> a. Keyboard b. (Trained service technician only) System board

- Follow the suggested actions in the order in which they are listed in the Action column until the problem is solved.
- See Chapter 3, “Parts listing, Type 7984 and 7986 servers,” on page 63 to determine which components are customer replaceable units (CRU) and which components are field replaceable units (FRU).
- If an action step is preceded by “(Trained service technician only),” that step must be performed only by a trained service technician.

Error code	Description	Action
302-xxx-000	Failed mouse test.	<ol style="list-style-type: none"> 1. Make sure that: <ul style="list-style-type: none"> • The mouse or pointing-device USB cable is securely connected to the server, and the keyboard and the device drivers are installed correctly. • The server and the monitor are turned on. • Keyboardless operation has been enabled in the Configuration/Setup Utility program. 2. Reseat the mouse or pointing-device cable. 3. If you are using an external USB hub, disconnect the mouse or pointing device from the hub and connect it directly to the server. 4. Replace the following components one at a time, in the order shown, restarting the server each time: <ol style="list-style-type: none"> a. Mouse or pointing device b. (Trained service technician only) System board
405-xxx-000	Failed Ethernet test on controller on the system board.	<ol style="list-style-type: none"> 1. Make sure that Ethernet is not disabled in BIOS (see “Using the Configuration/Setup Utility program” on page 109). 2. (Trained service technician only) Replace the system board.
405-xxx-00n	Failed Ethernet test on adapter in PCI Express slot <i>n</i> .	<p>Reseat the adapter in PCI Express slot <i>n</i>. Replace the following components one at a time, in the order shown, restarting the server each time:</p> <ol style="list-style-type: none"> 1. Adapter in PCI Express slot <i>n</i> 2. (Trained service technician only) System board
405-xxx-a0n	Failed Ethernet test on adapter in PCI Express slot <i>a</i> .	<ol style="list-style-type: none"> 1. For <i>a</i> = 0, (trained service technician only) replace the system board. 2. For <i>a</i> = 1 or 2, <ol style="list-style-type: none"> a. Reseat the adapter in PCI Express slot <i>a</i>. b. Replace the adapter in PCI Express slot <i>a</i>.
415-xxx-000	Failed modem test.	<ol style="list-style-type: none"> 1. Make sure that the modem is present and connected to the server. 2. Reseat the modem cable. 3. Replace the following components one at a time, in the order shown, restarting the server each time: <ol style="list-style-type: none"> a. Modem cable b. Modem c. (Trained service technician only) System board

Recovering from a BIOS update failure

If power to the server is interrupted while BIOS code is being updated, the server might not restart correctly or might not display video. If this happens, complete the following steps to recover:

1. Read the safety information that begins on page “Safety” on page vii.
2. Turn off the server and peripheral devices and disconnect all power cords and external cables; then, remove the server from the rack.
3. Remove the server cover (“Removing the cover” on page 71).
4. Locate the boot block recovery jumper (J51) on the system board, and remove any adapter that impedes access to the jumper (see “Removing an adapter” on page 76).

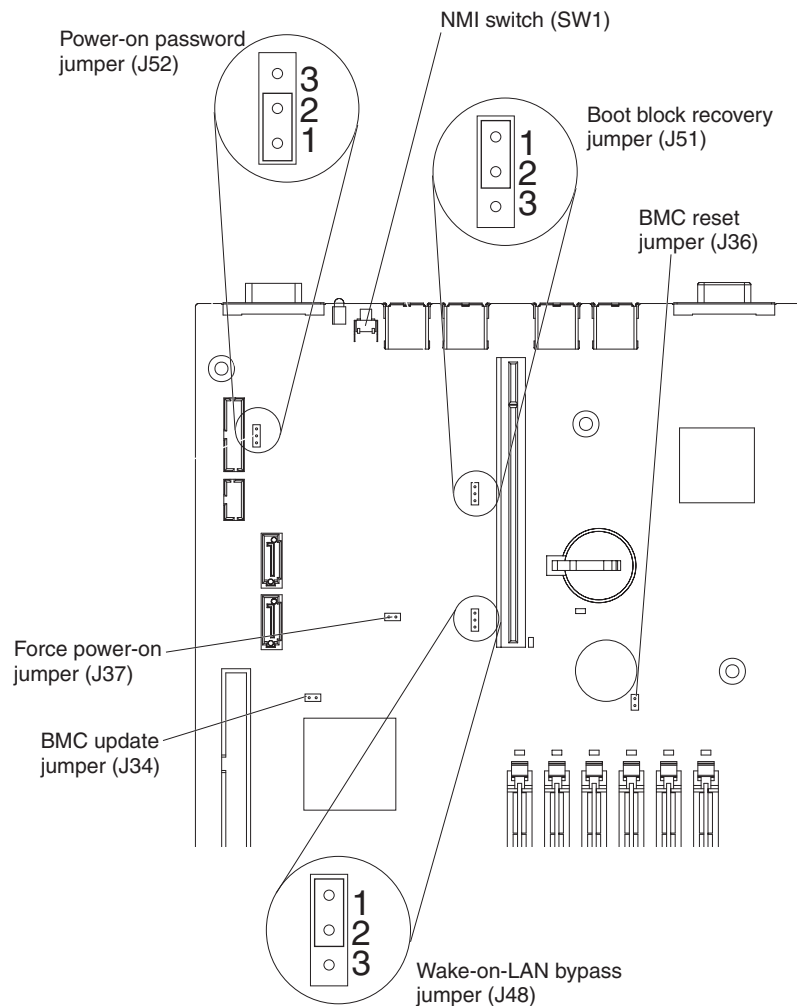

5. Move the boot block recovery jumper from pins 1 and 2 to pins 2 and 3.
6. Install the cover (see “Installing the cover” on page 71); then, install the server in the rack.
7. Reconnect all external cables and power cords.
8. Insert the BIOS update CD or diskette.
9. Turn on the server and the monitor. After the update session is completed, remove the CD or diskette from the drive.
10. Turn off the server and disconnect the power cord; then, remove the server from the rack.

11. Remove the cover.
12. Move the boot block recovery jumper from pins 2 and 3 to pins 1 and 2.
13. Replace any adapters that you removed (see “Installing an adapter” on page 77); then, install the cover (see “Installing the cover” on page 71).
14. Install the server in the rack.
15. Reconnect the external cables and power cords; then, turn on the attached devices and turn on the server.

BMC system-event log messages

The BMC system event log, which you can view through the Configuration/Setup Utility program (see “Viewing error logs from the Configuration/Setup Utility program” on page 20), contains information, warning, and error messages.

The following table describes the possible BMC system-event log messages and suggested actions to correct the detected problems.

Note: When you are instructed to reseal the microprocessor, complete the following steps:

1. (Trained service technician only) Remove the heat sink and the microprocessor from the server (see “Removing a microprocessor” on page 102).
2. (Trained service technician only) Visually inspect the microprocessor and the microprocessor socket for damage.

Attention: If the layer of thermal grease is disturbed, the microprocessor might overheat and be damaged.

3. (Trained service technician only) Reinstall the microprocessor and the heat sink in the server, taking special care that the layer of thermal grease is intact (see “Installing a microprocessor” on page 103).

- Follow the suggested actions in the order in which they are listed in the Action column until the problem is solved.
- See Chapter 3, “Parts listing, Type 7984 and 7986 servers,” on page 63 to determine which components are customer replaceable units (CRU) and which components are field replaceable units (FRU).
- If an action step is preceded by “(Trained service technician only),” that step must be performed only by a trained service technician.

BMC log message	Action
CPU <i>n</i> DIMM <i>m</i> DIMM single-bit error (Sensor number 00) <i>n</i> = the CPU number (1 or 2) <i>m</i> = the DIMM number	<ol style="list-style-type: none"> 1. Reseat DIMM <i>m</i>. 2. Replace DIMM <i>m</i>.
CPU <i>n</i> DIMM <i>m</i> DIMM multi-bit error (Sensor number 00) <i>n</i> = the CPU number (1 or 2) <i>m</i> = the DIMM number	<ol style="list-style-type: none"> 1. Reseat DIMM <i>m</i>. 2. Replace DIMM <i>m</i>.
Planar 1.2V (Sensor number 12) <ul style="list-style-type: none"> • Upper critical asserted • Lower critical asserted 	Information only.
Planar 3.3v (Sensor number 16) <ul style="list-style-type: none"> • Upper critical asserted • Lower critical asserted 	<ol style="list-style-type: none"> 1. Remove all PCI Express adapters. 2. Reinstall each PCI Express adapter, one at a time, restarting the server each time, to isolate a defective adapter. Replace any defective adapter. 3. (Trained service technician only) replace the system board.
Planar 5V (Sensor number 17) <ul style="list-style-type: none"> • Upper critical asserted • Lower critical asserted 	<ol style="list-style-type: none"> 1. Remove the following devices, which are powered by 5 volts: <ul style="list-style-type: none"> • All PCI Express adapters • USB devices • CD or DVD drive 2. Reinstall each I/O device that you removed in step 1, one at a time, restarting the server each time, to isolate a defective device. Replace any defective device. 3. (Trained service technician only) replace the system board.
Planar VBAT (Sensor number 1D) <ul style="list-style-type: none"> • Upper critical asserted • Lower critical asserted 	Replace the battery.
VRD <i>n</i> power supply failure (Sensor number 24, 25) <i>n</i> = the VRD number	<ol style="list-style-type: none"> 1. Replace the power supply. 2. (Trained service technician only) Reseat microprocessor <i>n</i>. 3. (Trained service technician only) Replace microprocessor <i>n</i>. 4. (Trained service technician only) Replace the system board.
VRD <i>n</i> presence detected (Sensor number 24, 25)	Information only.
Ambient temp upper non-critical (Sensor number 32)	<ol style="list-style-type: none"> 1. Make sure that the fans are operating and are not obstructed. 2. Make sure that the air baffle is in place and correctly installed. 3. Make sure that the server cover is installed and fully closed.

- Follow the suggested actions in the order in which they are listed in the Action column until the problem is solved.
- See Chapter 3, “Parts listing, Type 7984 and 7986 servers,” on page 63 to determine which components are customer replaceable units (CRU) and which components are field replaceable units (FRU).
- If an action step is preceded by “(Trained service technician only),” that step must be performed only by a trained service technician.

BMC log message	Action
Ambient temp upper non-recoverable (Sensor number 32)	<ol style="list-style-type: none"> 1. Make sure that the fans are operating and are not obstructed. 2. Make sure that the air baffle is in place and correctly installed. 3. Make sure that the server cover is installed and fully closed. 4. (Trained service technician only) Replace the system board.
Fan <i>n</i> tach lower-critical (Sensor number 40, 41, or 42) <i>n</i> = the fan number	<ol style="list-style-type: none"> 1. Make sure that the air baffle is in place and correctly installed. 2. Make sure that fan <i>n</i> is fully seated (press down on the fan). 3. Reseat the fan <i>n</i> cable. 4. Replace fan <i>n</i>. 5. (Trained service technician only) Replace the system board.
PS 1 fan fault asserted (Sensor number 73)	<ol style="list-style-type: none"> 1. Make sure that there are no obstructions, such as bundled cables, to the airflow on the power-supply fans. 2. Replace the power supply.
PS 1 fan fault deasserted (Sensor number 73)	Information only.
PS 1 thermal fault asserted (Sensor number 77)	<ol style="list-style-type: none"> 1. Make sure that there are no obstructions, such as bundled cables, to the airflow on the power-supply fans. 2. Replace the power supply.
PS 1 thermal fault deasserted (Sensor number 77)	Information only.
FP cable detect - device removed/absent (Sensor number 83)	<ol style="list-style-type: none"> 1. Reseat the front panel cable. 2. Replace the front panel cable. 3. Replace the front panel.
FP cable detect - device inserted/present (Sensor number 83)	Information only.
CPU <i>n</i> status - thermal trip asserted (Sensor number 90 or 91) <i>n</i> = the microprocessor number	<ol style="list-style-type: none"> 1. Make sure that the fans are operating, that there are no obstructions to the airflow, that the air baffles are in place and correctly installed, and that the server cover is installed and completely closed. 2. (Trained service technician only) Make sure that the heat sink for microprocessor <i>n</i> is installed correctly. 3. (Trained service technician only) Replace microprocessor <i>n</i>.
CPU <i>n</i> status - thermal trip de-asserted (Sensor number 90 or 91)	Information only.
CPU <i>n</i> processor presence de-asserted (Sensor number 90 or 91) <i>n</i> = the microprocessor number	<ol style="list-style-type: none"> 1. (Trained service technician only) Reseat microprocessor <i>n</i>. 2. (Trained service technician only) Replace microprocessor <i>n</i>. 3. (Trained service technician only) Replace the system board.
CPU <i>n</i> processor presence asserted (Sensor number 90 or 91)	Information only.

- Follow the suggested actions in the order in which they are listed in the Action column until the problem is solved.
- See Chapter 3, “Parts listing, Type 7984 and 7986 servers,” on page 63 to determine which components are customer replaceable units (CRU) and which components are field replaceable units (FRU).
- If an action step is preceded by “(Trained service technician only),” that step must be performed only by a trained service technician.

BMC log message	Action
CPU <i>n</i> processor disabled asserted (Sensor number 90 or 91) <i>n</i> = the microprocessor number	<ol style="list-style-type: none"> 1. (Trained service technician only) Reseat microprocessor <i>n</i>. 2. (Trained service technician only) Replace microprocessor <i>n</i>. 3. (Trained service technician only) Replace the system board.
CPU <i>n</i> processor disabled de-asserted (Sensor number 90 or 91)	Information only.
CPU <i>n</i> temp - upper non-critical asserted (Sensor number 90 or 91) <i>n</i> = the microprocessor number	<ol style="list-style-type: none"> 1. Make sure that the fans are operating, that there are no obstructions to the airflow, that the air baffles are in place and correctly installed, and that the server cover is installed and completely closed. 2. (Trained service technician only) Make sure that the heat sink for microprocessor <i>n</i> is installed correctly.
CPU <i>n</i> temp - upper non-critical de-asserted (Sensor number 98 or 99)	Information only.
CPU <i>n</i> temp - upper non-recoverable asserted (Sensor number 98 or 99) <i>n</i> = the microprocessor number	<ol style="list-style-type: none"> 1. Make sure that the fans are operating, that there are no obstructions to the airflow, that the air baffles are in place and correctly installed, and that the server cover is installed and completely closed. 2. (Trained service technician only) Make sure that the heat sink for microprocessor <i>n</i> is installed correctly. 3. (Trained service technician only) Replace microprocessor <i>n</i> 4. (Trained service technician only) Replace the system board.
CPU <i>n</i> temp - upper non-recoverable de-asserted (Sensor number 98 or 99)	Information only.
Primary HT2100 initiated sync flood: PCI-e slot <i>n</i> error (Sensor number AB)	<ol style="list-style-type: none"> 1. Reseat the adapter in slot <i>n</i>. 2. Replace the adapter in slot <i>n</i>. 3. (Trained service technician only) Replace the system board.
Primary HT2100 initiated sync flood: HT upbound or downbound error (Sensor number AB)	(Trained service technician only) Replace the system board.
HT1000 initiated sync flood: Legacy I/O error (Sensor number AB)	(Trained service technician only) Replace the system board.
Processor <i>n</i> initiated sync flood: Slot <i>n</i> error (possible timeout condition) (Sensor number AB)	<ol style="list-style-type: none"> 1. Reseat the adapter in slot <i>n</i>. 2. Replace the adapter in slot <i>n</i>. 3. (Trained service technician only) Replace the system board.
Processor <i>n</i> initiated sync flood: Processor <i>n</i> failed (Sensor number AB)	<ol style="list-style-type: none"> 1. Reseat microprocessor <i>n</i>. 2. (Trained service technician only) Replace microprocessor <i>n</i>.

<ul style="list-style-type: none"> • Follow the suggested actions in the order in which they are listed in the Action column until the problem is solved. • See Chapter 3, “Parts listing, Type 7984 and 7986 servers,” on page 63 to determine which components are customer replaceable units (CRU) and which components are field replaceable units (FRU). • If an action step is preceded by “(Trained service technician only),” that step must be performed only by a trained service technician. 	
BMC log message	Action
Processor <i>n</i> initiated sync flood: DIMM <i>n</i> failed (Sensor number AB)	<ol style="list-style-type: none"> 1. Reseat DIMM <i>n</i>. 2. Replace DIMM <i>n</i>. 3. Reseat microprocessor <i>n</i>. 4. (Trained service technician only) Replace microprocessor <i>n</i>.
System resetting due to unrecoverable error (Sensor number AB)	Check the light path error LEDs for faults.
SELx % full asserted (Sensor number B6) <i>x</i> = 100, over 90, over 75	Clear the system-event log (see “Clearing the error logs” on page 20).
CPU <i>n</i> procbat asserted (Sensor number C0 or C1) <i>n</i> = the microprocessor number	<ol style="list-style-type: none"> 1. Make sure that the fans are operating, that there are no obstructions to the airflow, that the air baffles are in place and correctly installed, and that the server cover is installed and completely closed. 2. (Trained service technician only) Make sure that the heat sink for microprocessor <i>n</i> is installed correctly. 3. (Trained service technician only) Replace microprocessor <i>n</i> 4. (Trained service technician only) Replace the system board.
CPU <i>n</i> procbat de-asserted (Sensor number C0 or C1)	Information only.
CPU <i>n</i> bad VID asserted (Sensor number 9C or 9D) <i>n</i> = the microprocessor number	<ol style="list-style-type: none"> 1. (Trained service technician only) Reseat microprocessor <i>n</i>. 2. (Trained service technician only) Replace microprocessor <i>n</i>. 3. (Trained service technician only) Replace the system board.
CPU <i>n</i> bad VID de-asserted (Sensor number 9C or 9D)	Information only.

Erasing a lost or forgotten password (clearing CMOS)

If the power-on or administrator password is lost or forgotten, you can regain access to the server through one of the following methods:

- If you have forgotten the power-on password and an administrator password is set, type the administrator password at the power-on prompt; then, start the Configuration/Setup Utility program and change the power-on password (see the *User's Guide* on the IBM System x Documentation CD for more information).
- If you have forgotten the administrator password, clear all CMOS settings by removing and reinstalling the system-board battery.

To clear CMOS and reset the administrator and power-on passwords, complete the following steps:

1. Read the safety information that begins on page vii and “Installation guidelines” on page 69.
2. Turn off the server and peripheral devices and disconnect all power cords and external cables; then, remove the server from the rack.

3. Remove the server cover (“Removing the cover” on page 71) and any adapters that restrict access to the system-board battery (“Removing an adapter” on page 76).

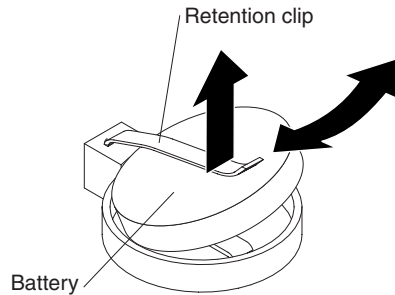

4. Slide the battery out from the retention clip.
5. Wait 60 seconds; then, reinsert the battery.
6. Replace any adapters that you removed and install the cover (see “Installing the cover” on page 71); then, slide the server into the rack.
7. Reconnect the power cord; then, connect the server to a keyboard, monitor, and mouse.
You can now start the server without having to use any password.
8. Start the Configuration/Setup Utility program and reset the configuration parameters:
 - Set the system date and time.
 - Set the administrator password.
 - Set the power-on password.
 - Reconfigure the server.See “Using the Configuration/Setup Utility program” on page 109 for details.
9. Click **Save Settings** and exit the Configuration/Setup Utility program; then, turn off the server and disconnect the keyboard, monitor, and mouse.
10. Slide the server into the rack.
11. Reconnect the power cords and any cables that you removed.
12. Turn on the peripheral devices and the server.

Solving power problems

Power problems can be difficult to solve. For example, a short circuit can exist anywhere on any of the power distribution buses. Usually, a short circuit will cause the power subsystem to shut down because of an overcurrent condition. To diagnose a power problem, use the following general procedure:

1. Turn off the server and disconnect all ac power cords.
2. Check for loose cables in the power subsystem. Also check for short circuits, for example, if a loose screw is causing a short circuit on a circuit board.
3. Remove the adapters and disconnect the cables and power cords to all internal and external devices until the server is at the minimum configuration that is required for the server to start (see “Solving undetermined problems” on page 60 for the minimum configuration).
4. Reconnect all ac power cords and turn on the server. If the server starts successfully, reseat the adapters and devices one at a time until the problem is isolated.

If the server does not start from the minimum configuration (see “Power-supply LEDs” on page 43), replace the components in the minimum configuration one at a time until the problem is isolated.

Solving Ethernet controller problems

The method that you use to test the Ethernet controller depends on which operating system you are using. See the operating-system documentation for information about Ethernet controllers, and see the Ethernet controller device-driver readme file.

Try the following procedures:

- Make sure that the correct device drivers, which come with the server, are installed and that they are at the latest level.
- Make sure that the Ethernet cable is installed correctly.
 - The cable must be securely attached at all connections. If the cable is attached but the problem remains, try a different cable.
 - If you set the Ethernet controller to operate at 100 Mbps, you must use Category 5 cabling.
 - If you directly connect two servers (without a hub), or if you are not using a hub with X ports, use a crossover cable. To determine whether a hub has an X port, check the port label. If the label contains an X, the hub has an X port.
- Determine whether the hub supports auto-negotiation. If it does not, try configuring the integrated Ethernet controller manually to match the speed and duplex mode of the hub.
- Check the Ethernet controller LEDs on the rear panel of the server. These LEDs indicate whether there is a problem with the connector, cable, or hub.
 - The Ethernet link status LED is lit when the Ethernet controller receives a link pulse from the hub. If the LED is off, there might be a defective connector or cable or a problem with the hub.
 - The Ethernet transmit/receive activity LED is lit when the Ethernet controller sends or receives data over the Ethernet network. If the Ethernet transmit/receive activity light is off, make sure that the hub and network are operating and that the correct device drivers are installed.
- Check the LAN activity LED on the rear of the server. The LAN activity LED is lit when data is active on the Ethernet network. If the LAN activity LED is off, make sure that the hub and network are operating and that the correct device drivers are installed.
- Check for operating-system-specific causes of the problem.
- Make sure that the device drivers on the client and server are using the same protocol.

If the Ethernet controller still cannot connect to the network but the hardware appears to be working, the network administrator must investigate other possible causes of the error.

Solving undetermined problems

If the diagnostic tests did not diagnose the failure or if the server is inoperative, use the information in this section.

If you suspect that a software problem is causing failures (continuous or intermittent), see “Software problems” on page 41.

Damaged data in CMOS memory or damaged BIOS code can cause undetermined problems. To reset the CMOS data, clear the CMOS memory, and override the power-on password (see “Erasing a lost or forgotten password (clearing CMOS)” on page 57). If you suspect that the BIOS code is damaged, see “Updating the firmware” on page 109.

If the power supply is working correctly, complete the following steps:

1. Turn off the server.
2. Make sure that the server is cabled correctly.
3. Remove or disconnect the following devices, one at a time, until you find the failure. Turn on the server and reconfigure it each time.
 - Any external devices.
 - Printer, mouse, and non-IBM devices.
 - Each adapter.
 - Hard disk drives.
 - CD or DVD drive
 - Memory modules. The minimum configuration requirement is 1 GB (two 512 MB DIMMs in DIMM slots 5 and 6).
 - Microprocessor 2 (if installed)
4. Turn on the server.

If the problem is solved when you remove an adapter from the server but the problem recurs when you reinstall the same adapter, suspect the adapter; if the problem recurs when you replace the adapter with a different one, suspect the riser card.

If you suspect a networking problem and the server passes all the system tests, suspect a network cabling problem that is external to the server.

Calling IBM for service

See Appendix A, “Getting help and technical assistance,” on page 113 for information about calling IBM for service.

When you call for service, have as much of the following information available as possible:

- Machine type and model
- Microprocessor and hard disk drive upgrades
- Failure symptoms
 - Does the server fail the diagnostic programs? If so, what are the error codes?
 - What occurs? When? Where?
 - Is the failure repeatable?
 - Has the current server configuration ever worked?
 - What changes, if any, were made before it failed?
 - Is this the original reported failure, or has this failure been reported before?

- Diagnostic program type and version level
- Hardware configuration (print screen of the system summary)
- BIOS code level
- Operating-system type and version level

You can solve some problems by comparing the configuration and software setups between working and nonworking servers. When you compare servers to each other for diagnostic purposes, consider them identical only if all the following factors are exactly the same in all the servers:

- Machine type and model
- BIOS level
- Memory amount, type, and configuration
- Adapters and attachments, in the same locations
- Address jumpers, terminators, and cabling
- Software versions and levels
- Diagnostic program type and version level
- Configuration option settings
- Operating-system control-file setup

Chapter 3. Parts listing, Type 7984 and 7986 servers

The following replaceable components are available for the System x3455 Types 7984 and 7986 servers. To check for an updated parts listing on the Web, complete the following steps:

1. Go to <http://www.ibm.com/servers/eserver/support/xseries/index.html>
2. From the **Hardware** list, select **System** x3455 and click **Go**.
3. Click the **Install and use** tab.
4. Under **Technical resources**, select **Parts information**.

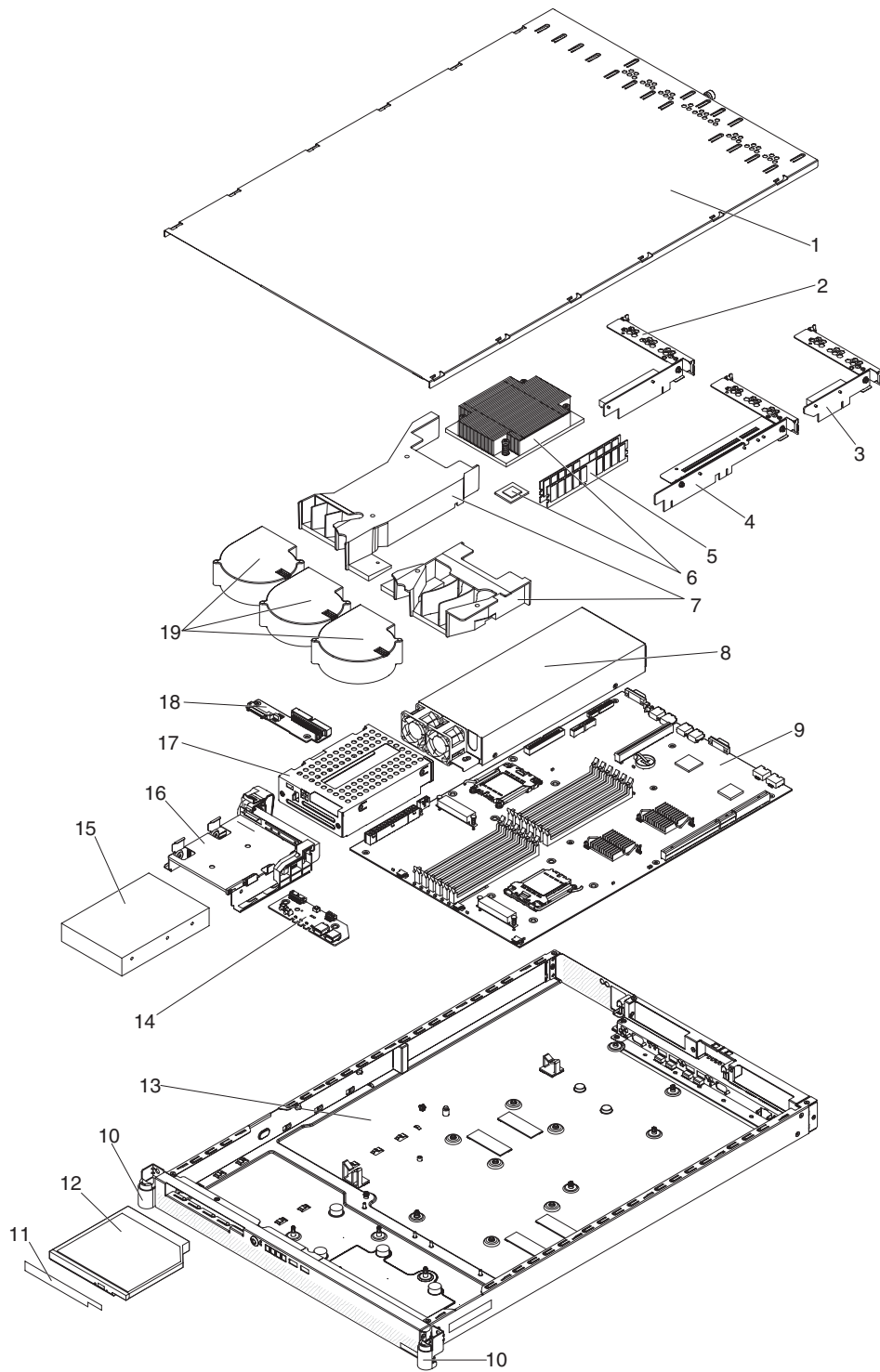

Replaceable server components

Replaceable components are of three types:

- **Tier 1 customer replaceable unit (CRU):** Replacement of Tier 1 CRUs is your responsibility. If IBM installs a Tier 1 CRU at your request, you will be charged for the installation.
- **Tier 2 customer replaceable unit:** You may install a Tier 2 CRU yourself or request IBM to install it, at no additional charge, under the type of warranty service that is designated for your server.
- **Field replaceable unit (FRU):** FRUs must be installed only by trained service technicians.

For information about the terms of the warranty and getting service and assistance, see the *Warranty and Support Information* document.

Table 4. Parts listing, Types 7984 and 7986

Index	Description	CRU part number (Tier 1)	CRU part number (Tier 2)	FRU part number
1	Top cover	40K7138		
2	Riser card, PCI Express x16		40K7160	
3	Riser card, PCI Express x8		40K7162	
4	Riser card, HTX (optional)		40K7166	
5	Memory, 512 MB (all models)	41Y2758		
5	Memory, 1 GB	41Y2761		
5	Memory, 2 GB	41Y2764		
5	Memory, 4 GB	41Y2767		
6	Microprocessor, 1.8 GHz, with heat sink (model 11x)			40K7439
6	Microprocessor, 2.2 GHz, with heat sink (model 31x)			40K7574
6	Microprocessor, 2.4 GHz, with heat sink (model 41x)			40K7441
6	Microprocessor, 2.6 GHz, with heat sink (models 51x, 52x)			40K7442
6	Microprocessor, 2.8 GHz, with heat sink (models 6Ax)			40K7440
7	Air baffle kit	40K7148		
8	Power supply, 650 W	40K7172		
9	System board			40K7164
10	EIA rack latches	90P5285		
11	Filler, CD or DVD drive bay		41Y0457	
12	CD/RW-DVD drive (model 31x)		39M3541	
13	Chassis assembly			40K7136
14	Operator information panel		40K7140	
15	Hard disk drive, 3.5-inch, 80 GB		39M4503	
16	Hard disk drive cage, front, 3.5-inch		40K7145	
17	Hard disk drive cage, rear, 3.5-inch		40K7146	
18	CD-RW/DVD backplane		40K7168	
19	Fan	40K7184		
	Battery, system board, 3.0 V	33F8354		

Table 4. Parts listing, Types 7984 and 7986 (continued)

Index	Description	CRU part number (Tier 1)	CRU part number (Tier 2)	FRU part number
	Bracket kit			42C9420
	Cable, CD-RW/DVD		40K7158	
	Cable, front panel		40K7152	
	Cable, front panel USB		40K7150	
	Cable, HDD, SAS/SATA		40K7154	
	CD-ROM combo (optional)	39M3559		
	Ethernet adapter, PRO/1000 GT (optional)		39Y6107	
	Ethernet adapter, NetXtreme 1000 express (optional)		73P3509	
	Ethernet adapter, NetXtreme 1000 SX plus fiber channel (optional)		73P4009	
	Ethernet adapter, NetXtreme 1000 T (optional)		73P4109	
	Ethernet adapter, NetXtreme 1000 T, dual port (optional)		73P4209	
	Ethernet adapter, PRO/1000 GT, dual port Server (optional)		73P5109	
	Hard disk drive, 160 GB (optional)	39M4507		
	Hard disk drive, 250 GB (optional)	39M4511		
	Heatsink, copper base			40K7170
	Heatsink, heat pipe base			40K7245
	Label kit	42C9440		
	Line cord, 125/250 Vac 10 amp 2.8M	39M5377		
	Rail kit	26K8077		
	Service label, system	40K7538		

Power cords

For your safety, IBM provides a power cord with a grounded attachment plug to use with this IBM product. To avoid electrical shock, always use the power cord and plug with a properly grounded outlet.

IBM power cords used in the United States and Canada are listed by Underwriter's Laboratories (UL) and certified by the Canadian Standards Association (CSA).

For units intended to be operated at 115 volts: Use a UL-listed and CSA-certified cord set consisting of a minimum 18 AWG, Type SVT or SJT, three-conductor cord, a maximum of 15 feet in length and a parallel blade, grounding-type attachment plug rated 15 amperes, 125 volts.

For units intended to be operated at 230 volts (U.S. use): Use a UL-listed and CSA-certified cord set consisting of a minimum 18 AWG, Type SVT or SJT, three-conductor cord, a maximum of 15 feet in length and a tandem blade, grounding-type attachment plug rated 15 amperes, 250 volts.

For units intended to be operated at 230 volts (outside the U.S.): Use a cord set with a grounding-type attachment plug. The cord set should have the appropriate safety approvals for the country in which the equipment will be installed.

IBM power cords for a specific country or region are usually available only in that country or region.

IBM power cord part number	Used in these countries and regions
39M5206	China
39M5102	Australia, Fiji, Kiribati, Nauru, New Zealand, Papua New Guinea
39M5123	Afghanistan, Albania, Algeria, Andorra, Angola, Armenia, Austria, Azerbaijan, Belarus, Belgium, Benin, Bosnia and Herzegovina, Bulgaria, Burkina Faso, Burundi, Cambodia, Cameroon, Cape Verde, Central African Republic, Chad, Comoros, Congo (Democratic Republic of), Congo (Republic of), Cote D'Ivoire (Ivory Coast), Croatia (Republic of), Czech Republic, Dahomey, Djibouti, Egypt, Equatorial Guinea, Eritrea, Estonia, Ethiopia, Finland, France, French Guyana, French Polynesia, Germany, Greece, Guadeloupe, Guinea, Guinea Bissau, Hungary, Iceland, Indonesia, Iran, Kazakhstan, Kyrgyzstan, Laos (People's Democratic Republic of), Latvia, Lebanon, Lithuania, Luxembourg, Macedonia (former Yugoslav Republic of), Madagascar, Mali, Martinique, Mauritania, Mauritius, Mayotte, Moldova (Republic of), Monaco, Mongolia, Morocco, Mozambique, Netherlands, New Caledonia, Niger, Norway, Poland, Portugal, Reunion, Romania, Russian Federation, Rwanda, Sao Tome and Principe, Saudi Arabia, Senegal, Serbia, Slovakia, Slovenia (Republic of), Somalia, Spain, Suriname, Sweden, Syrian Arab Republic, Tajikistan, Tahiti, Togo, Tunisia, Turkey, Turkmenistan, Ukraine, Upper Volta, Uzbekistan, Vanuatu, Vietnam, Wallis and Futuna, Yugoslavia (Federal Republic of), Zaire
39M5130	Denmark
39M5144	Bangladesh, Lesotho, Macao, Maldives, Namibia, Nepal, Pakistan, Samoa, South Africa, Sri Lanka, Swaziland, Uganda
39M5151	Abu Dhabi, Bahrain, Botswana, Brunei Darussalam, Channel Islands, China (Hong Kong S.A.R.), Cyprus, Dominica, Gambia, Ghana, Grenada, Iraq, Ireland, Jordan, Kenya, Kuwait, Liberia, Malawi, Malaysia, Malta, Myanmar (Burma), Nigeria, Oman, Polynesia, Qatar, Saint Kitts and Nevis, Saint Lucia, Saint Vincent and the Grenadines, Seychelles, Sierra Leone, Singapore, Sudan, Tanzania (United Republic of), Trinidad and Tobago, United Arab Emirates (Dubai), United Kingdom, Yemen, Zambia, Zimbabwe
39M5158	Liechtenstein, Switzerland
39M5165	Chile, Italy, Libyan Arab Jamahiriya
39M5172	Israel
39M5095	220 - 240 V Antigua and Barbuda, Aruba, Bahamas, Barbados, Belize, Bermuda, Bolivia, Brazil, Caicos Islands, Canada, Cayman Islands, Colombia, Costa Rica, Cuba, Dominican Republic, Ecuador, El Salvador, Guam, Guatemala, Haiti, Honduras, Jamaica, Japan, Mexico, Micronesia (Federal States of), Netherlands Antilles, Nicaragua, Panama, Peru, Philippines, Taiwan, United States of America, Venezuela

IBM power cord part number	Used in these countries and regions
39M5081	110 - 120 V Antigua and Barbuda, Aruba, Bahamas, Barbados, Belize, Bermuda, Bolivia, Caicos Islands, Canada, Cayman Islands, Colombia, Costa Rica, Cuba, Dominican Republic, Ecuador, El Salvador, Guam, Guatemala, Haiti, Honduras, Jamaica, Mexico, Micronesia (Federal States of), Netherlands Antilles, Nicaragua, Panama, Peru, Philippines, Saudi Arabia, Thailand, Taiwan, United States of America, Venezuela
39M5219	Korea (Democratic People's Republic of), Korea (Republic of)
39M5199	Japan
39M5068	Argentina, Paraguay, Uruguay
39M5226	India
39M5233	Brazil

Chapter 4. Removing and replacing server components

Replaceable components are of three types:

- **Tier 1 customer replaceable unit (CRU):** Replacement of Tier 1 CRUs is your responsibility. If IBM installs a Tier 1 CRU at your request, you will be charged for the installation.
- **Tier 2 customer replaceable unit:** You may install a Tier 2 CRU yourself or request IBM to install it, at no additional charge, under the type of warranty service that is designated for your server.
- **Field replaceable unit (FRU):** FRUs must be installed only by trained service technicians.

See Chapter 3, “Parts listing, Type 7984 and 7986 servers,” on page 63 to determine whether a component is a Tier 1 CRU, Tier 2 CRU, or FRU.

For information about the terms of the warranty and getting service and assistance, see the *Warranty and Support Information* document.

Installation guidelines

Before you remove or replace a component, read the following information:

- Read the safety information that begins on page vii and the guidelines in “Handling static-sensitive devices” on page 70. This information will help you work safely.
- Observe good housekeeping in the area where you are working. Place removed covers and other parts in a safe place.
- If you must start the server while the cover is removed, make sure that no one is near the server and that no other objects have been left inside the server.
- Do not attempt to lift an object that you think is too heavy for you. If you have to lift a heavy object, observe the following precautions:
 - Make sure that you stand safely without slipping.
 - Distribute the weight of the object equally between your feet.
 - Use a slow lifting force. Never move suddenly or twist when you lift a heavy object.
 - To avoid straining the muscles in your back, lift by standing or by pushing up with your leg muscles
- Make sure that you have an adequate number of properly grounded electrical outlets for the server, monitor, and other devices.
- Back up all important data before you make changes to disk drives.
- Have a small flat-blade screwdriver available.
- You do not have to turn off the server to install or replace hot-plug Universal Serial Bus (USB) devices.
- Blue on a component indicates touch points, where you can grip the component to remove it from or install it in the server, open or close a latch, and so on.
- When you are finished working on the server, reinstall all safety shields, guards, labels, and ground wires.
- For a list of supported optional devices for the server, see <http://www.ibm.com/servers/eserver/serverproven/compat/us/>.

System reliability guidelines

To help ensure proper cooling and system reliability, make sure that the following requirements are met:

- The CD or DVD drive tray has a drive or a filler panel and electromagnetic compatibility (EMC) shield installed in it.
- There is adequate space around the server to allow the server cooling system to work properly. Leave approximately 50 mm (2 in.) of open space around the front and rear of the server. Do not place objects in front of the fans. For proper cooling and airflow, replace the server cover before turning on the server. Operating the server for extended periods of time (more than 30 minutes) with the server cover removed might damage server components.
- You have followed the cabling instructions that come with optional adapters.
- You have replaced a failed fan as soon as possible.
- You have kept the preinstalled air deflector in place unless you are directed to remove it in this document or by IBM Service. See “Removing an air baffle” on page 72 for the location of the air deflector in the server.

Handling static-sensitive devices

Attention: Static electricity can damage the server and other electronic devices. To avoid damage, keep static-sensitive devices in their static-protective packages until you are ready to install them.

To reduce the possibility of damage from electrostatic discharge, observe the following precautions:

- Limit your movement. Movement can cause static electricity to build up around you.
- The use of a grounding system is recommended. For example, wear an electrostatic-discharge wrist strap, if one is available. Always use an electrostatic-discharge wrist strap or other grounding system when you work inside the server with the power on.
- Handle the device carefully, holding it by its edges or its frame.
- Do not touch solder joints, pins, or exposed circuitry.
- Do not leave the device where others can handle and damage it.
- While the device is still in its static-protective package, touch it to an unpainted metal part on the outside of the server for at least 2 seconds. This drains static electricity from the package and from your body.
- Remove the device from its package and install it directly into the server without setting down the device. If it is necessary to set down the device, put it back into its static-protective package. Do not place the device on the server cover or on a metal surface.
- Take additional care when handling devices during cold weather. Heating reduces indoor humidity and increases static electricity.

Returning a device or component

If you are instructed to return a device or component, follow all packaging instructions, and use any packaging materials for shipping that are supplied to you.

Removing and replacing Tier 1 CRUs

Replacement of Tier 1 CRUs is your responsibility. If IBM installs a Tier 1 CRU at your request, you will be charged for the installation.

The illustrations in this document might differ slightly from your hardware.

Removing the cover

To remove the server cover, complete the following steps.

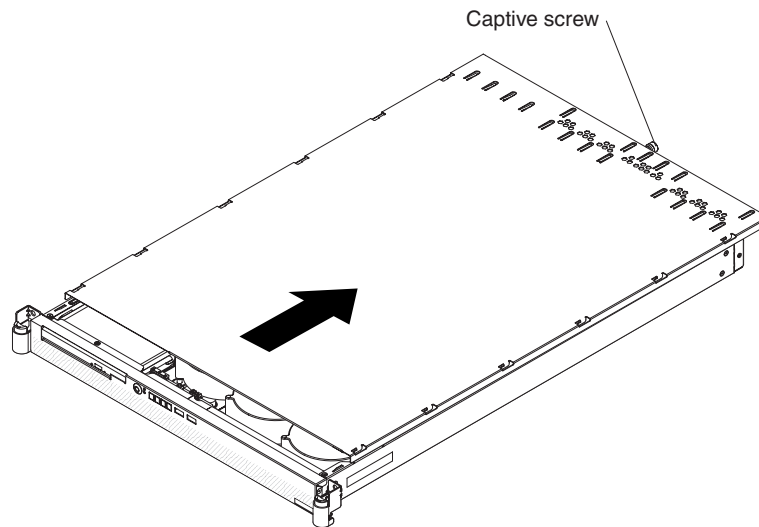

Attention:

- For proper cooling and airflow, replace the cover before you turn on the server. Operating the server for extended periods of time (more than 30 minutes) with the cover removed might damage server components.
 - Do *not* remove the server cover with the power on.
1. Read the safety information that begins on page vii and “Installation guidelines” on page 69.
 2. Turn off the server and peripheral devices and disconnect all power cords and external cables; then, remove the server from the rack.
 3. Remove the cover from the server:
 - a. Loosen the captive screw on the back of the cover.
 - b. Disengage the tabs on the sides of the cover from the matching slots on the sides of the chassis.
 - c. Slide the cover toward the rear of the server, and lift the cover off the server.

Installing the cover

To install the server cover, complete the following steps:

1. Position the internal cables so that they do not interfere with the cover installation.

Important: Before you slide the cover forward, make sure that all the tabs on the cover engage the chassis correctly. If all the tabs do not engage the chassis correctly, it will be very difficult to remove the cover later.

2. Install the cover:
 - a. Place the cover on top of the server so that all the tabs engage the matching slots on the chassis.

- b. Slide the cover forward slightly.
- c. Tighten the captive screw on the back of the cover.

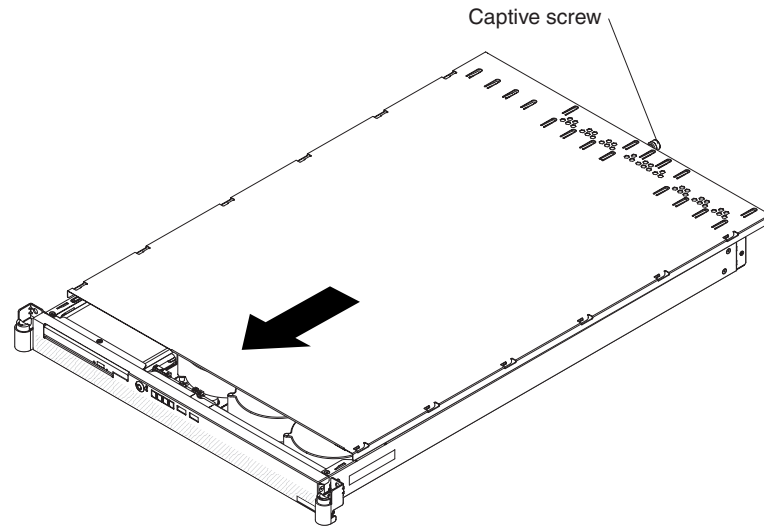

3. Slide the server all the way into the rack until it latches.
4. Reconnect the power cords and any cables that you removed.
5. Turn on the peripheral devices and the server.

Removing an air baffle

To remove an air baffle, complete the following steps.

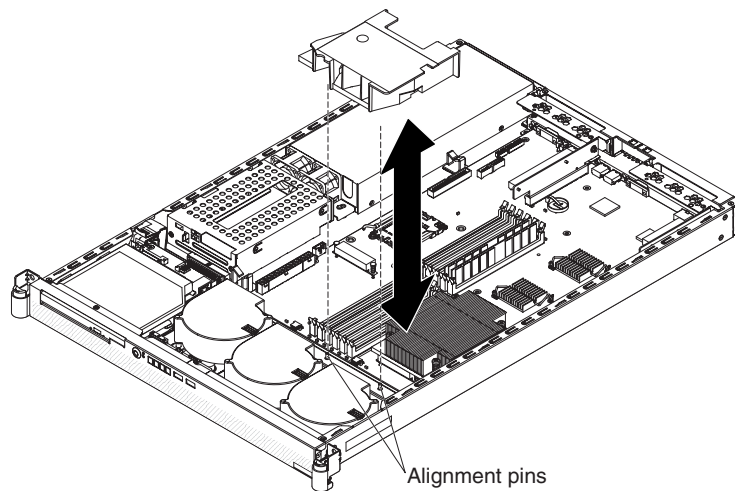

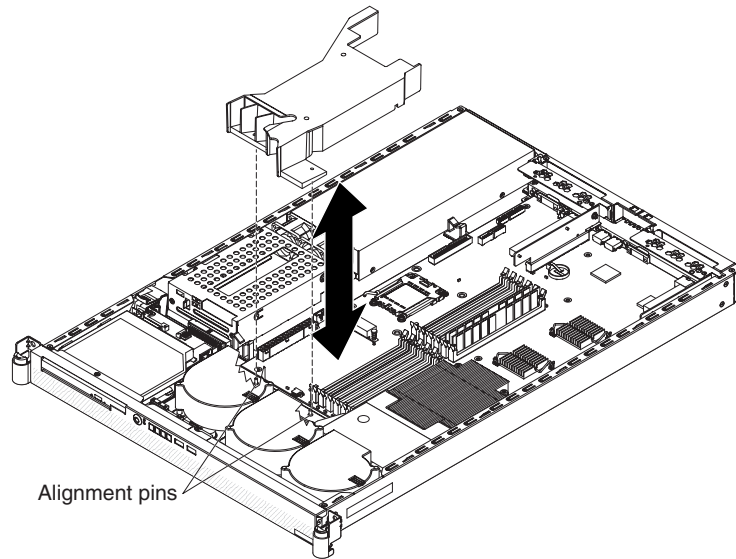

1. Read the safety information that begins on page vii and “Installation guidelines” on page 69.
2. Turn off the server and peripheral devices and disconnect all power cords and external cables; then, remove the server from the rack.
3. Remove the server cover (see “Removing the cover” on page 71).
4. Lift the baffle up and out of the server.

Attention: For proper cooling and airflow, replace the air baffle before you turn on the server. Operating the server with the air baffle removed might damage server components.
5. If you are instructed to return the air baffle, follow all packaging instructions, and use any packaging materials for shipping that are supplied to you.

Installing an air baffle

To install an air baffle, complete the following steps.

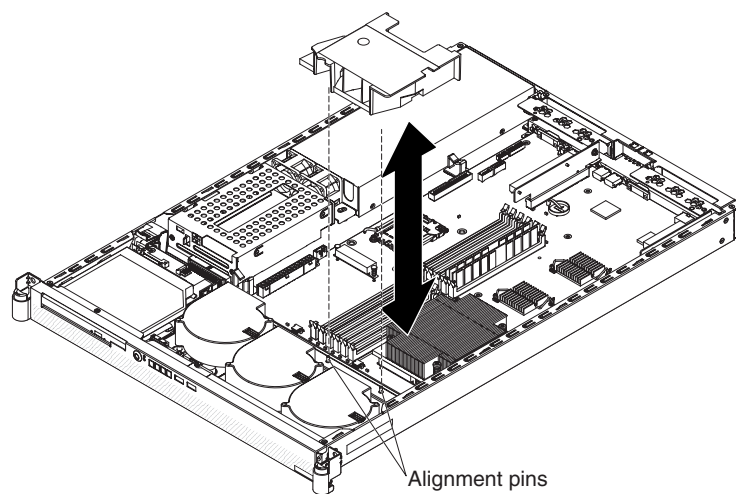

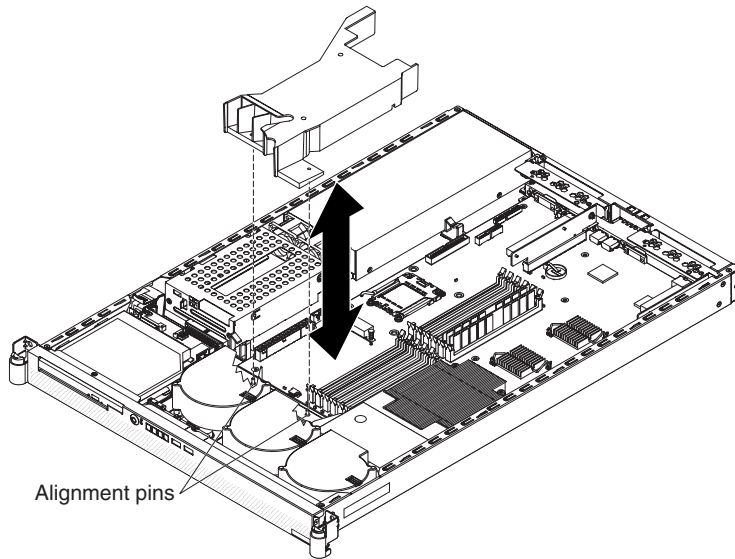

1. Read the safety information that begins on page vii and “Installation guidelines” on page 69.
2. Put the baffle into place from the top of the server, and align the holes near the front of the baffle with the pins in the server. Make sure that the pins on the rear of the baffle are seated in the system board.

Attention: For proper cooling and airflow, replace the air baffle before you turn on the server. Operating the server with the air baffle removed might damage server components.

3. Install the cover (see “Installing the cover” on page 71).
4. Slide the server all the way into the rack until it latches.
5. Reconnect the power cords and any cables that you removed.
6. Turn on the peripheral devices and the server.

Removing a riser-card assembly

To remove an HTX or PCI Express riser-card assembly, complete the following steps.

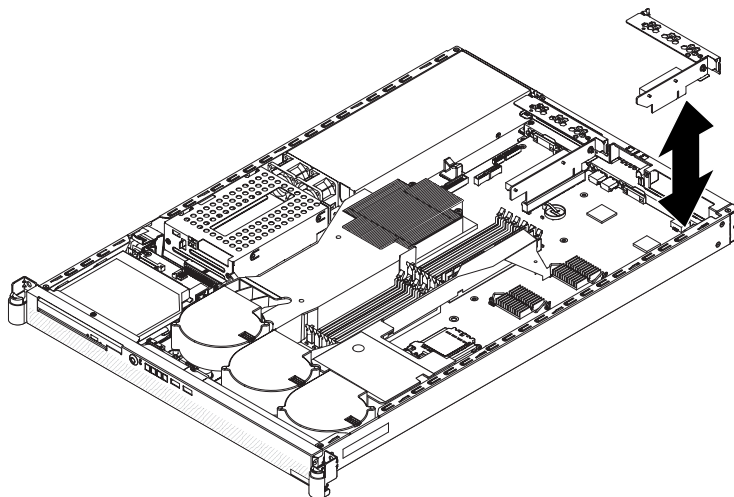

1. Read the safety information that begins on page vii and “Installation guidelines” on page 69.

2. Turn off the server and peripheral devices and disconnect all power cords and external cables; then, remove the server from the rack.
3. Remove the server cover (see “Removing the cover” on page 71).
4. Grasp the riser-card assembly at the rear edge and lift straight up to remove it from the server.
5. Place the riser-card assembly on a flat, static-protective surface.
6. If an adapter is installed, remove it from the riser-card assembly (see “Removing an adapter” on page 76).
7. If you are instructed to return the riser card, follow all packaging instructions, and use any packaging materials for shipping that are supplied to you.

Installing a riser-card assembly

To install a riser-card assembly, complete the following steps.

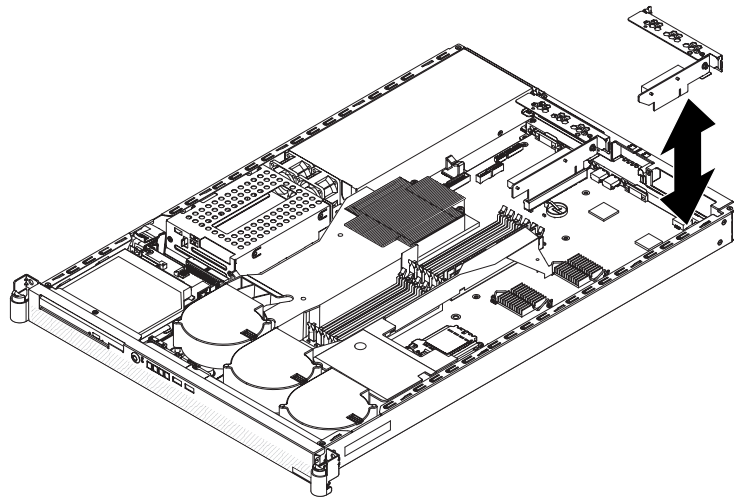

1. Reinstall any adapters that you removed from the riser card (see “Installing an adapter” on page 77).
2. Carefully align the riser-card assembly with the guides at the rear of the server and the riser-card connector on the system board; then, press down on the assembly. Make sure that the riser-card assembly is fully seated in the riser-card connector.
3. Reconnect any cables that you removed from the adapter.
4. Install the cover (see “Installing the cover” on page 71).
5. Slide the server into the rack.
6. Reconnect the power cords and any cables that you removed.
7. Turn on the peripheral devices and the server.

Removing an adapter

To remove an HTX or PCI Express adapter, complete the following steps.

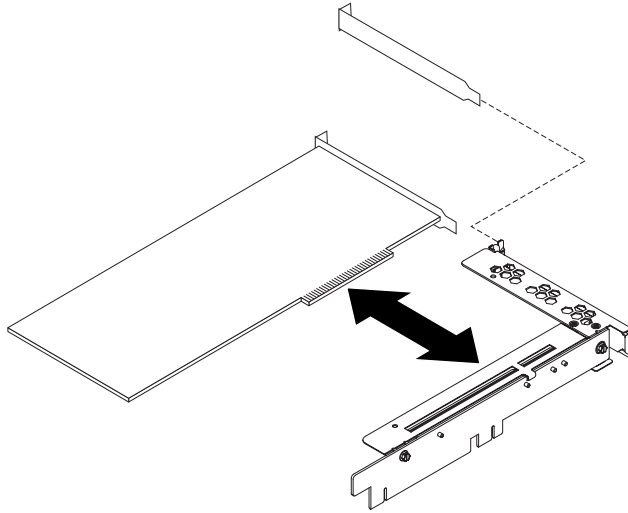

1. Read the safety information that begins on page vii and “Installation guidelines” on page 69.
2. Turn off the server and peripheral devices and disconnect all power cords and external cables; then, remove the server from the rack.
3. Remove the server cover (see “Removing the cover” on page 71).
4. Disconnect any cables from the adapter.
5. Remove the riser-card assembly from the server (see “Removing a riser-card assembly” on page 74).
6. Carefully grasp the adapter by its top edge or upper corners, and pull the adapter from the slot.
7. If you are instructed to return the adapter, follow all packaging instructions, and use any packaging materials for shipping that are supplied to you.

Installing an adapter

To install an HTX or PCI Express adapter, complete the following steps.

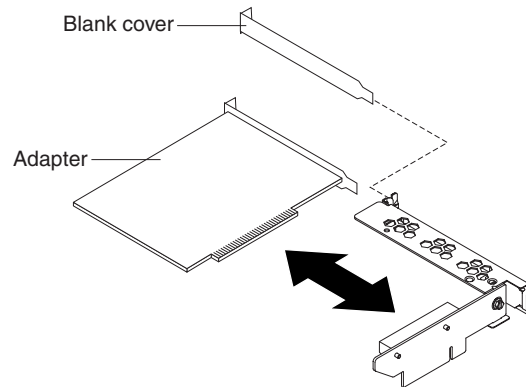

1. Remove the adapter from the static-protective package and set any jumpers or switches on the adapter as directed by the adapter manufacturer.
2. Route the adapter cables, if any, before you install the adapter in the riser-card assembly.
3. Align the edge connector on the adapter with the connector on the riser-card assembly. Press the adapter firmly into the riser-card assembly connector so that the adapter edge connector seats fully.

Attention: When you install an adapter, make sure that the adapter is correctly seated in the connector before you turn on the server. An incorrectly seated adapter might cause damage to the system board, the riser-card assembly, or the adapter.

4. Install the riser-card assembly in the server (see “Installing a riser-card assembly” on page 75).
5. Perform any configuration tasks that are required for the adapter.
6. Install the cover (see “Installing the cover” on page 71).
7. Slide the server into the rack.
8. Reconnect the power cords and any cables that were removed.
9. Turn on the peripheral devices and the server.

Removing the CD or DVD drive

To remove the CD or DVD drive, complete the following steps:

1. If you are replacing a removed drive with a new drive, make sure that:
 - You have all the cables and other equipment that is specified in the documentation that comes with the new drive.
 - You check the instructions that come with the new drive to determine whether you must set any switches or jumpers on the drive.
 - You have removed the drive retainer clip on the side of the old drive and have it available for installation on the new drive.

Note: If you are installing a drive that contains a laser, observe the following safety precaution.

Statement 3:



CAUTION:

When laser products (such as CD-ROMs, DVD drives, fiber optic devices, or transmitters) are installed, note the following:

- Do not remove the covers. Removing the covers of the laser product could result in exposure to hazardous laser radiation. There are no serviceable parts inside the device.
- Use of controls or adjustments or performance of procedures other than those specified herein might result in hazardous radiation exposure.



DANGER

Some laser products contain an embedded Class 3A or Class 3B laser diode. Note the following.

Laser radiation when open. Do not stare into the beam, do not view directly with optical instruments, and avoid direct exposure to the beam.



Class 1 Laser Product
Laser Klasse 1
Laser Klass 1
Luokan 1 Laserlaite
Appareil À Laser de Classe 1

2. Read the safety information that begins on page vii and “Installation guidelines” on page 69.
3. Turn off the server and peripheral devices and disconnect all power cords and external cables; then, remove the server from the rack.
4. Remove the server cover (see “Removing the cover” on page 71).

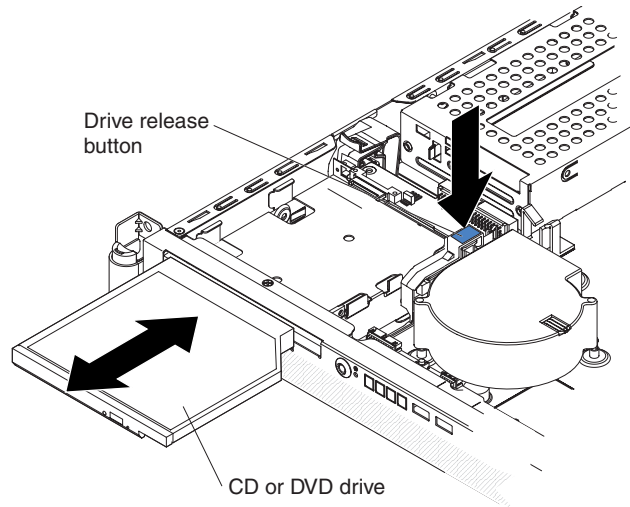

5. Press and hold the release button as you push the drive from the rear to slide it out of the bay.

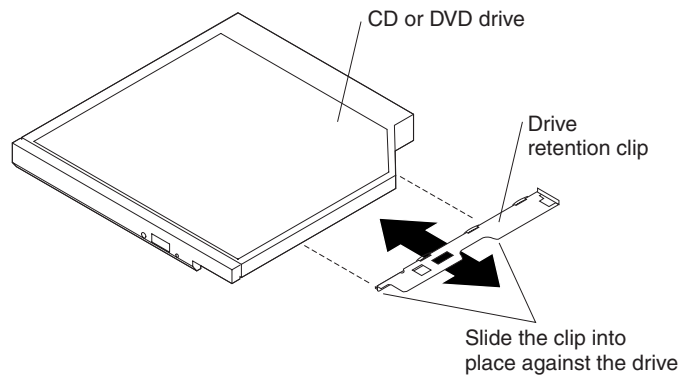

6. Slide the drive-retention clip to remove it from the drive.
7. If you are instructed to return the CD or DVD drive, follow all packaging instructions, and use any packaging materials for shipping that are supplied to you.

Installing the CD or DVD drive

To install the replacement CD or DVD drive, complete the following steps:

1. Read the safety information that begins on page vii and “Installation guidelines” on page 69.
2. Follow the instructions that come with the new drive to set any jumpers or switches.

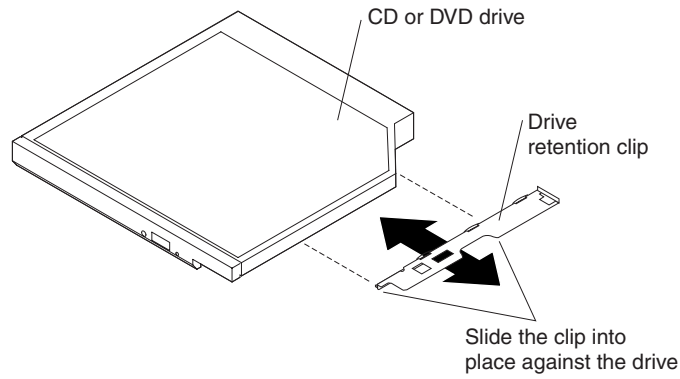

- Slide the drive-retention clip into place against the side of the drive.

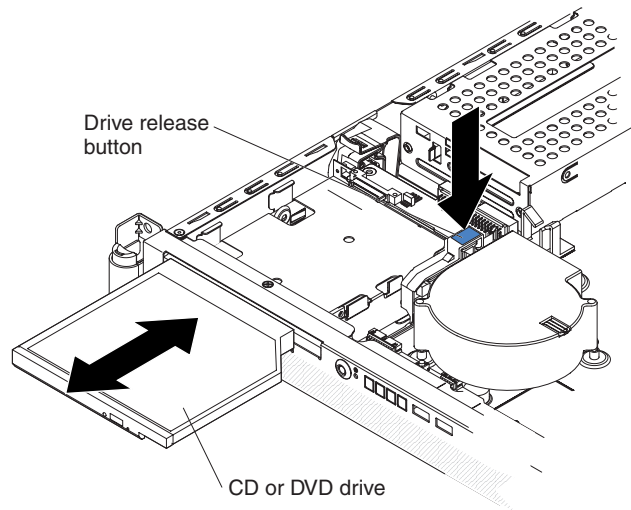

- Slide the drive into the server until the drive clicks into place.
- Install the cover (see "Installing the cover" on page 71).
- Slide the server into the rack.
- Reconnect the power cords and any cables that you removed.
- Turn on the peripheral devices and the server.

Removing a memory module (DIMM)

To remove a DIMM, complete the following steps.

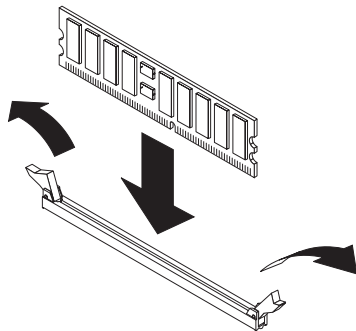

- Read the safety information that begins on page vii and "Installation guidelines" on page 69.

2. Turn off the server and peripheral devices and disconnect all power cords and external cables; then, remove the server from the rack.
3. Remove the server cover (see “Removing the cover” on page 71).
4. Open the retaining clip on each end of the DIMM connector.
Attention: To avoid breaking the retaining clips or damaging the DIMM connectors, open and close the clips gently.
5. Lift the DIMM out of the connector.
6. If you are instructed to return the DIMM, follow all packaging instructions, and use any packaging materials for shipping that are supplied to you.

Installing a memory module

For information about the types of dual inline memory modules (DIMMs) that the server supports and other information that you must consider when installing DIMMs, see the *User’s Guide* on the *IBM System x Documentation CD*.

To optimize system performance in a single-microprocessor or dual-microprocessor configuration, install DIMMs in the following sequence. Do not install DIMMs in connectors 7 through 12 if microprocessor socket 2 (system-board identifier CPU2) is empty.

Table 5. DIMM installation sequence

Number of DIMMs installed	DIMM connector population with one microprocessor installed	DIMM connector population with two microprocessors installed
2	1, 2	1, 2
4	1, 2, 3, 4	1, 2, 7, 8
6	1, 2, 3, 4, 5, 6	1, 2, 3, 4, 7, 8
8	Not supported	1, 2, 3, 4, 7, 8, 9, 10
10	Not supported	1, 2, 3, 4, 5, 6, 7, 8, 9, 10
12	Not supported	1, 2, 3, 4, 5, 6, 7, 8, 9, 10, 11, 12

The following illustration shows the DIMM slots (memory connectors) on the system board.

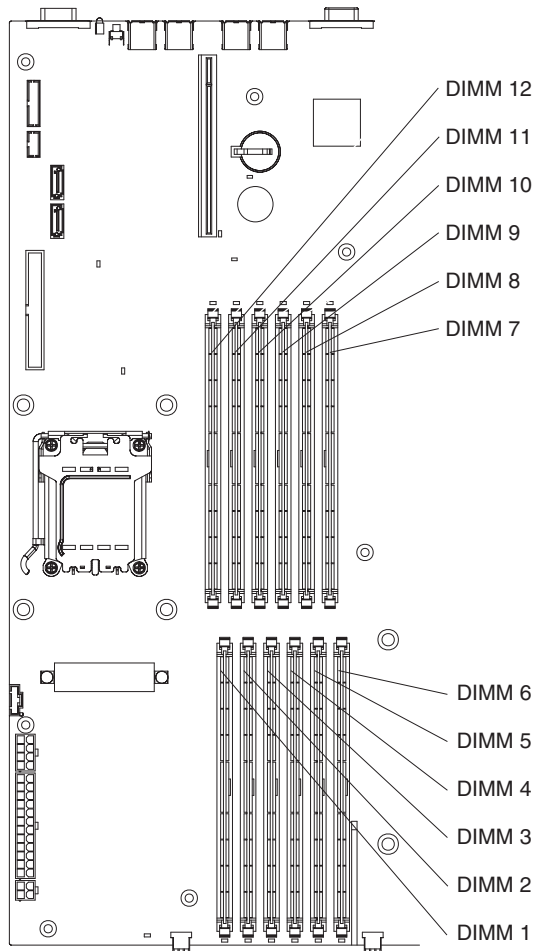

To install DIMMs, complete the following steps:

1. Read the safety information that begins on page vii and “Installation guidelines” on page 69.
2. Turn off the server and peripheral devices, and disconnect the power cords and all external cables.
3. Remove the server from the rack; then, remove the server cover (see “Removing the cover” on page 71).

Attention: To avoid breaking the retaining clips or damaging the DIMM connectors, open and close the clips gently.
4. Based on your server configuration, select the applicable DIMM installation sequence from Table 5 on page 81.
5. Open the retaining clip on each end of the DIMM connector.
6. Touch the static-protective package containing the DIMM to any unpainted metal surface on the server. Then, remove the DIMM from the package.
7. Turn the DIMM so that the DIMM keys align correctly with the slot.

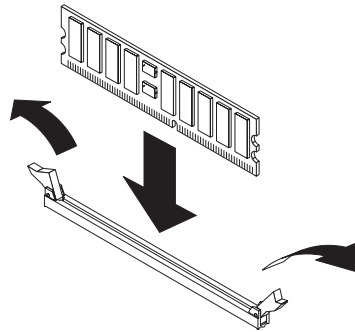

8. Insert the DIMM into the connector by aligning the edges of the DIMM with the slots at the ends of the DIMM connector. Firmly press the DIMM straight down into the connector by applying pressure on both ends of the DIMM simultaneously. The retaining clips snap into the locked position when the DIMM is firmly seated in the connector. If there is a gap between the DIMM and the retaining clips, the DIMM has not been correctly inserted; open the retaining clips, remove the DIMM, and then reinsert it.

Important: When you restart the server after you have installed DIMMs, the 162 code will be displayed to indicate that the server memory configuration has changed. You must run the Configuration/Setup Utility program to configure the DIMMs. For additional information, see the *User's Guide* on the IBM System x *Documentation CD*.

9. DIMMs must be installed in pairs. Repeat steps 5 through 8 for the second DIMM.
10. Install the cover (see "Installing the cover" on page 71).
11. Slide the server into the rack.
12. Reconnect the power cords and any cables that you removed.
13. Turn on the peripheral devices and the server.

Removing a fan

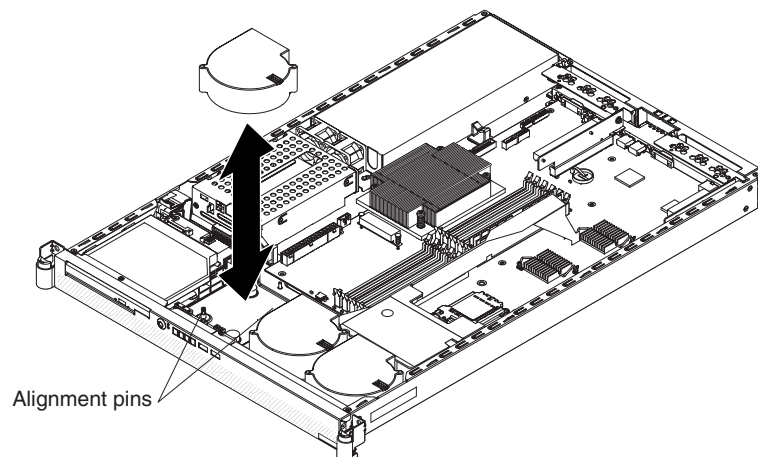

Attention: To ensure proper server operation, do not operate the server with a failed fan.

To remove a fan, complete the following steps:

1. Read the safety information that begins on page vii and "Installation guidelines" on page 69.

2. Turn off the server and peripheral devices and disconnect all power cords and external cables; then, remove the server from the rack.
3. Remove the server cover (see “Removing the cover” on page 71).
4. Disconnect the cable of the failing fan from the connector.
5. Lift the fan out of the server.
6. If you are instructed to return the fan, follow all packaging instructions, and use any packaging materials for shipping that are supplied to you.

Installing a fan

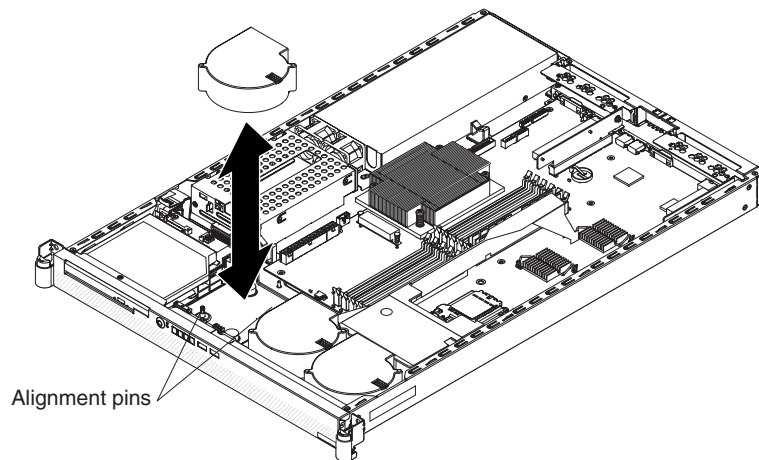

Attention: To ensure proper server operation, do not operate the server with a failed fan.

To replace a fan, complete the following steps:

1. Read the safety information that begins on page vii and “Installation guidelines” on page 69.
2. Push the fan assembly down into the server until it seats.
3. Connect the cable of the replacement fan to the connector.
4. Install the cover (see “Installing the cover” on page 71).
5. Slide the server into the rack.
6. Reconnect the power cords and any cables that you removed.
7. Turn on the peripheral devices and the server.

Removing the system-board battery

To remove the system-board battery, complete the following steps.

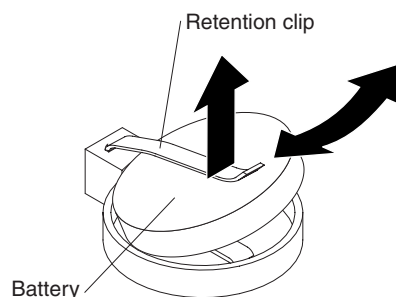

1. Read the safety information that begins on page vii and “Installation guidelines” on page 69.

2. Turn off the server and peripheral devices and disconnect all power cords and external cables; then, remove the server from the rack.
3. Remove the server cover (see “Removing the cover” on page 71).
4. Slide the battery out from the battery clip.
5. Dispose of the battery as required by local ordinances or regulations. See “Battery return program” on page 118 for more information.

Installing the system-board battery

The following notes describe information that you must consider when you replace the system-board battery in the server.

- When replacing the system-board battery, you must replace it with a lithium battery of the same type from the same manufacturer.
- To order replacement batteries, call 1-800-426-7378 within the United States, and 1-800-465-7999 or 1-800-465-6666 within Canada. Outside the U.S. and Canada, call your IBM marketing representative or authorized reseller.
- After you replace the system-board battery, you must reconfigure the server and reset the system date and time.
- To avoid possible danger, read and follow the following safety statement.

Statement 2:



CAUTION:

When replacing the lithium battery, use only IBM Part Number 33F8354 or an equivalent type battery recommended by the manufacturer. If your system has a module containing a lithium battery, replace it only with the same module type made by the same manufacturer. The battery contains lithium and can explode if not properly used, handled, or disposed of.

Do not:

- **Throw or immerse into water**
- **Heat to more than 100°C (212°F)**
- **Repair or disassemble**

Dispose of the battery as required by local ordinances or regulations.

To install the replacement system-board battery, complete the following steps.

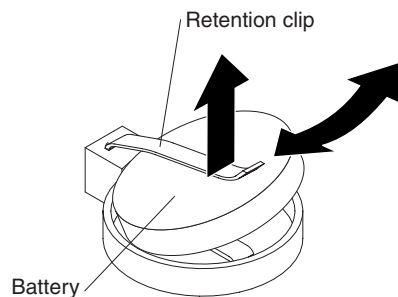

1. Follow any special handling and installation instructions that come with the replacement battery.
2. Slide the battery into place under the battery clip.
3. Install the cover (see “Installing the cover” on page 71).
4. Slide the server into the rack.
5. Reconnect the external cables; then, reconnect the power cords and turn on the peripheral devices and the server.
6. Start the Configuration/Setup Utility program and reset the configuration parameters.
 - Set the system date and time.
 - Set the power-on password.
 - Reconfigure the server.

See “Using the Configuration/Setup Utility program” on page 109 for details.

Removing the power supply

Statement 8:



CAUTION:

Never remove the cover on a power supply or any part that has the following label attached.



Hazardous voltage, current, and energy levels are present inside any component that has this label attached. There are no serviceable parts inside these components. If you suspect a problem with one of these parts, contact a service technician.

To remove the power supply, complete the following steps.

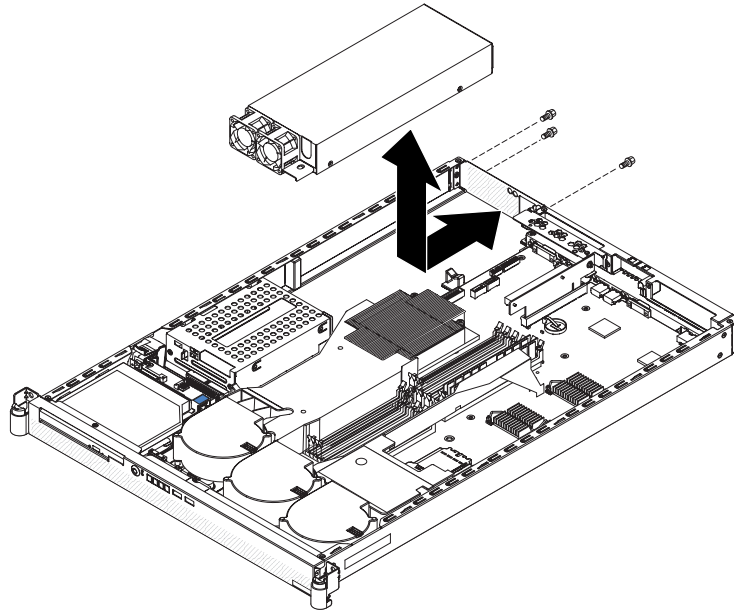

1. Read the safety information that begins on page vii and “Installation guidelines” on page 69.
2. Turn off the server and peripheral devices and disconnect all power cords and external cables; then, remove the server from the rack.
3. Remove the server cover (see “Removing the cover” on page 71).
4. Disconnect the power-supply connectors from the system board (and from all installed devices).
5. Remove the three power-supply mounting screws.

6. Slide the power supply slightly toward the front of the server to free the retainer pin from the keyhole; then, lift the power supply out of the server.
7. If you are instructed to return the power supply, follow all packaging instructions, and use any packaging materials for shipping that are supplied to you.

Installing the power supply

Statement 8:



CAUTION:

Never remove the cover on a power supply or any part that has the following label attached.



Hazardous voltage, current, and energy levels are present inside any component that has this label attached. There are no serviceable parts inside these components. If you suspect a problem with one of these parts, contact a service technician.

To install the power supply, complete the following steps.

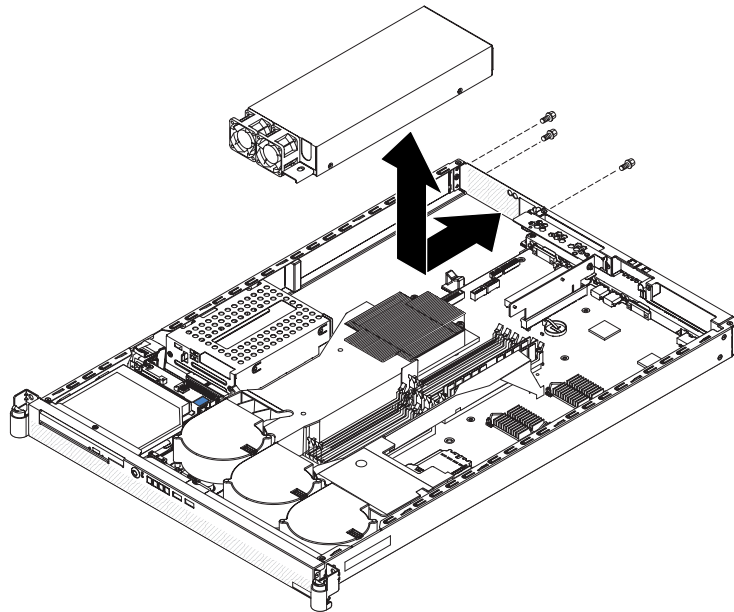

1. Read the safety information that begins on page vii and “Installation guidelines” on page 69.
2. Align the power supply keyhole with the chassis retainer pin.
3. Slide the power supply into position inside the server.
4. Install the three power-supply mounting screws.
5. Connect the power-supply cables to the system board (and to all installed devices).
6. Install the server cover (see “Installing the cover” on page 71).

7. Connect the power cord to the power-cord connector on the power supply.
8. Connect the other end of the power cord to a properly grounded electrical outlet.
9. Make sure that the ac power LED and the dc power LED on the rear of the power supply (see “Rear view” on page 6) are lit, indicating that the power supply is operating correctly.

Removing and replacing Tier 2 CRUs

You may install a Tier 2 CRU yourself or request IBM to install it, at no additional charge, under the type of warranty service that is designated for your server.

The illustrations in this document might differ slightly from your hardware.

Removing the operator information panel

To remove the operator information panel, complete the following steps.

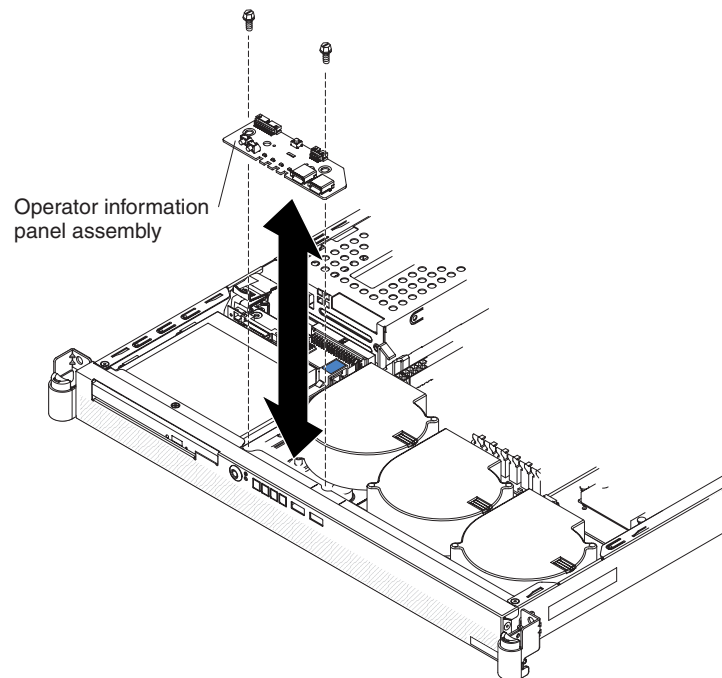

1. Read the safety information that begins on page vii and “Installation guidelines” on page 69.
2. Turn off the server and peripheral devices and disconnect all power cords and external cables; then, remove the server from the rack.
3. Remove the server cover (see “Removing the cover” on page 71).
4. Disconnect the signal cable and the USB cable from the operator information panel.
5. Remove the two mounting screws; then, remove the operator information panel from the server.
6. If you are instructed to return the operator information panel, follow all packaging instructions, and use any packaging materials for shipping that are supplied to you.

Installing the operator information panel

To install the operator information panel, complete the following steps.

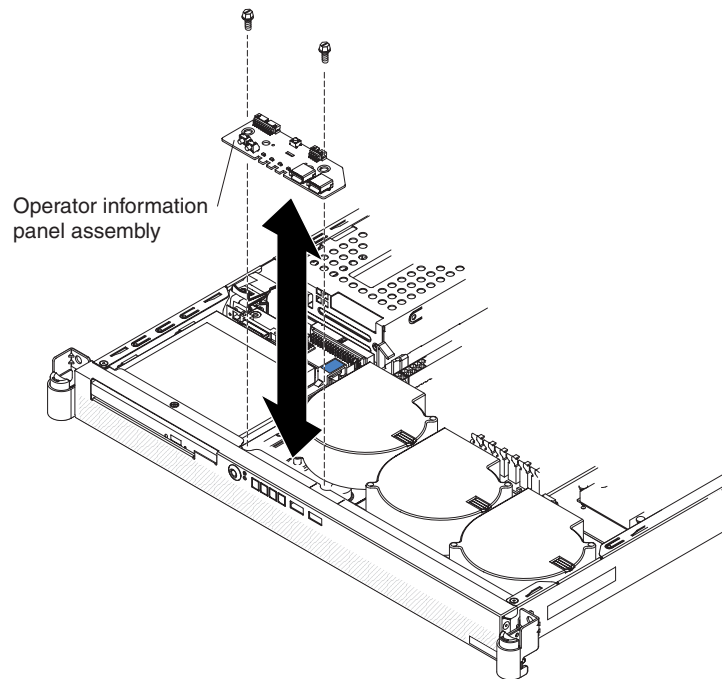

1. Install the operator information panel in the server and secure it with the two mounting screws.
2. Connect the signal cable and the USB cable to the operator information panel.
3. Install the cover (see "Installing the cover" on page 71).
4. Slide the server into the rack.
5. Reconnect the power cords and any cables that you removed.
6. Turn on the peripheral devices and the server.

Removing the CD or DVD backplane

To remove the CD or DVD backplane, complete the following steps.

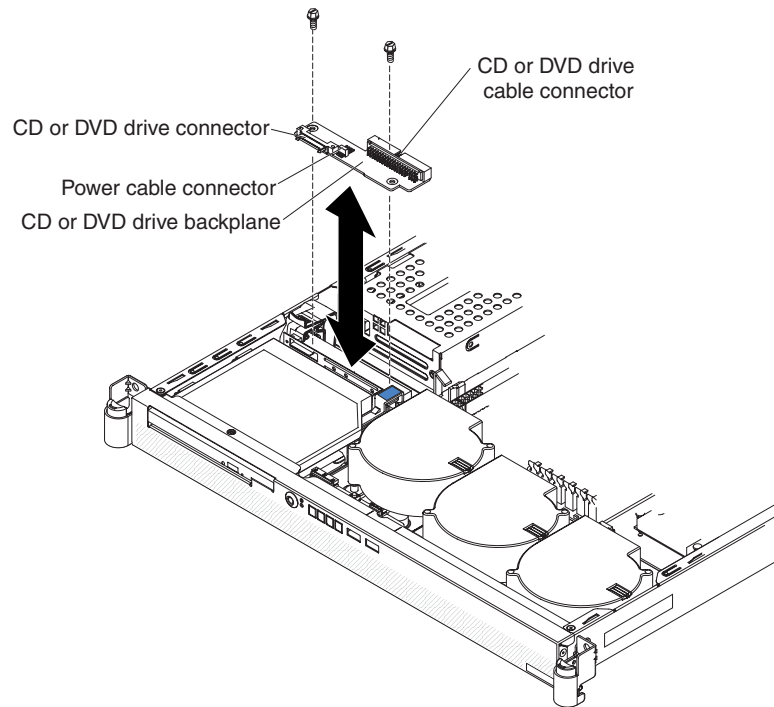

1. Read the safety information that begins on page vii and “Installation guidelines” on page 69.
2. Turn off the server and peripheral devices and disconnect all power cords and external cables; then, remove the server from the rack.
3. Remove the server cover (see “Removing the cover” on page 71).
4. Remove the CD or DVD drive (see “Removing the CD or DVD drive” on page 77), if present.
5. Disconnect the signal cable and the power cable from the CD or DVD backplane.
6. Remove the two mounting screws; then, remove the CD or DVD backplane from the server.
7. If you are instructed to return the backplane, follow all packaging instructions, and use any packaging materials for shipping that are supplied to you.

Installing the CD or DVD backplane

To install the CD or DVD backplane, complete the following steps.

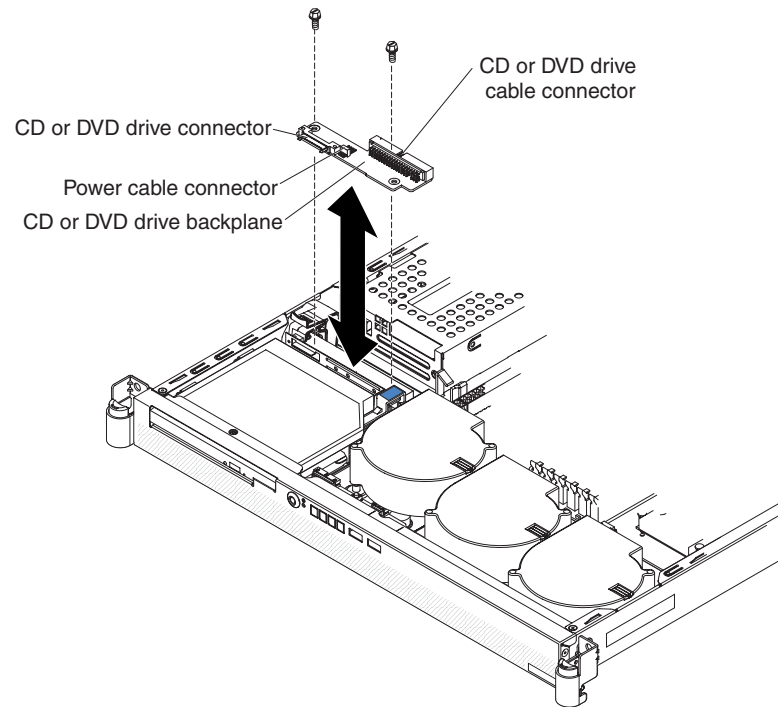

1. Install the CD or DVD backplane in the server and secure it with the two mounting screws.
2. Connect the signal cable and the power cable to the CD or DVD backplane.
3. Install the CD or DVD drive (see "Installing the CD or DVD drive" on page 79), if one was removed.
4. Install the cover (see "Installing the cover" on page 71).
5. Slide the server into the rack.
6. Reconnect the power cords and any cables that you removed.
7. Turn on the peripheral devices and the server.

Removing the front hard disk drive cage assembly

To remove the front hard disk drive cage assembly, complete the following steps.

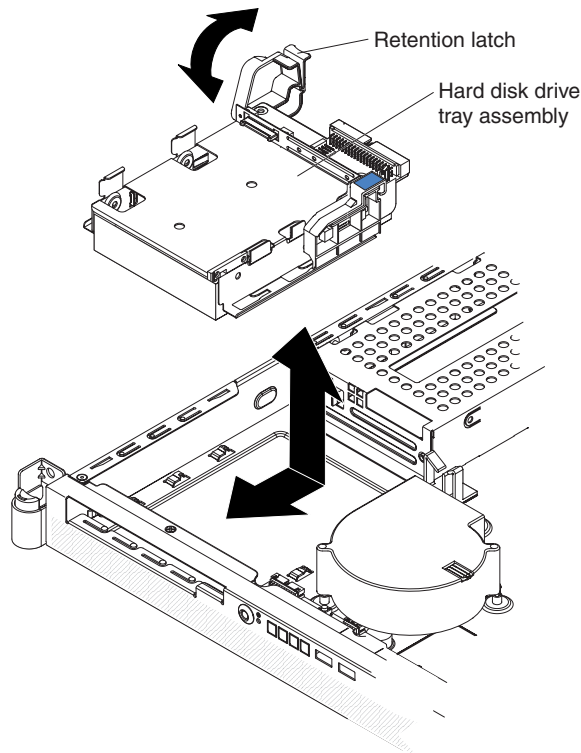

1. Read the safety information that begins on page vii and “Installation guidelines” on page 69.
2. Turn off the server and peripheral devices and disconnect all power cords and external cables; then, remove the server from the rack.
3. Remove the server cover. See “Removing the cover” on page 71.
4. If a CD or DVD drive is installed, remove it from the server (see “Removing the CD or DVD drive” on page 77).
5. Disconnect the power and signal cables from the CD or DVD drive backplane.
6. Open the drive-cage assembly retention latch; then, release the drive-cage assembly by sliding it slightly toward the rear of the server.
7. If a hard disk drive is installed, disconnect the hard disk drive power and signal cables. Note the cable locations for later use in reinstalling the hard disk drive.
8. Lift the drive-cage assembly out of the server.
9. If you are instructed to return the drive-cage assembly, follow all packaging instructions, and use any packaging materials for shipping that are supplied to you.

Installing the front hard disk drive cage assembly

To install the front hard disk drive cage assembly, complete the following steps.

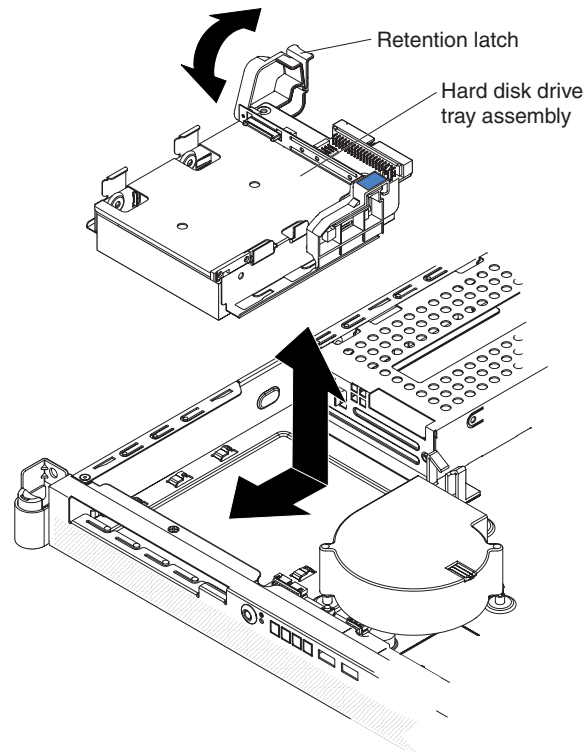

1. Read the safety information that begins on page vii and “Installation guidelines” on page 69.
2. If you removed a hard disk drive, reinstall it (see “Installing the front hard disk drive” on page 98).
3. Insert the drive-cage assembly into the server; then, slide the drive-cage assembly forward until it seats securely.
4. Close the drive-cage assembly retention latch.
5. Install the cover (see “Installing the cover” on page 71).
6. Slide the server into the rack.
7. Reconnect the power cords and any cables that you removed.
8. Turn on the peripheral devices and the server.
9. If you are instructed to return the disk drive cage assembly, follow all packaging instructions, and use any packaging materials for shipping that are supplied to you.

Removing the rear hard disk drive cage assembly

To remove the rear hard disk drive cage assembly, complete the following steps.

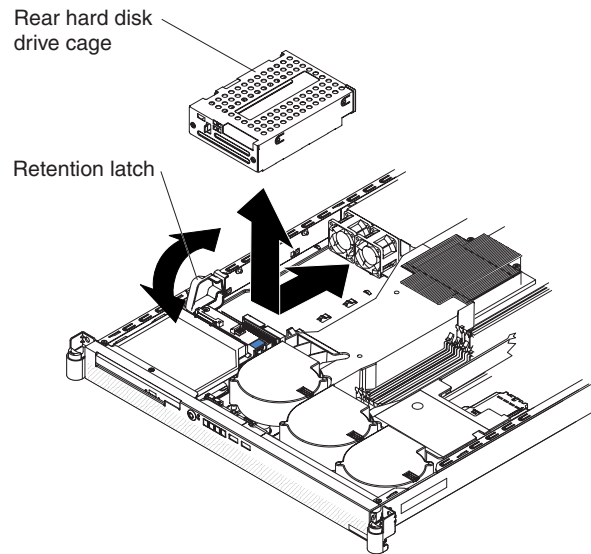

1. Read the safety information that begins on page vii and “Installation guidelines” on page 69.
2. Turn off the server and peripheral devices and disconnect all power cords and external cables; then, remove the server from the rack.
3. Remove the server cover. See “Removing the cover” on page 71.
4. Open the drive-cage assembly retention latch; then, release the drive-cage assembly by sliding it slightly toward the front of the server.
5. If a hard disk drive is installed, disconnect the hard disk drive power and signal cables. Note the cable locations for later use in reinstalling the hard disk drive.
6. Lift the drive-cage assembly out of the server.
7. If you are instructed to return the drive-cage assembly, follow all packaging instructions, and use any packaging materials for shipping that are supplied to you.

Installing the rear hard disk drive cage assembly

To install the rear hard disk drive cage assembly, complete the following steps.

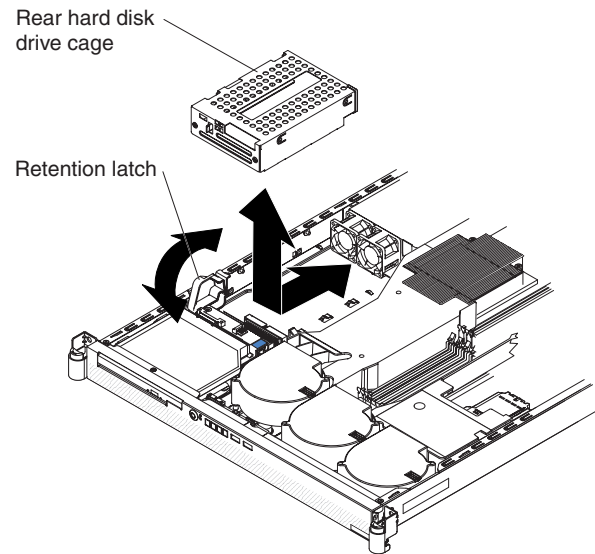

1. Read the safety information that begins on page vii and “Installation guidelines” on page 69.
2. If you removed a hard disk drive, reinstall it (see “Installing the rear hard disk drive” on page 100).
3. Insert the drive-cage assembly into the server; then, slide the drive-cage assembly toward the rear of the server until it seats securely.
4. Close the drive-cage assembly retention latch.
5. Install the cover (see “Installing the cover” on page 71).
6. Slide the server into the rack.
7. Reconnect the power cords and any cables that you removed.
8. Turn on the peripheral devices and the server.

Removing the front hard disk drive

Locate the documentation that comes with the hard disk drive and follow those instructions in addition to the instructions in this chapter.

To remove the front hard disk drive, complete the following steps.

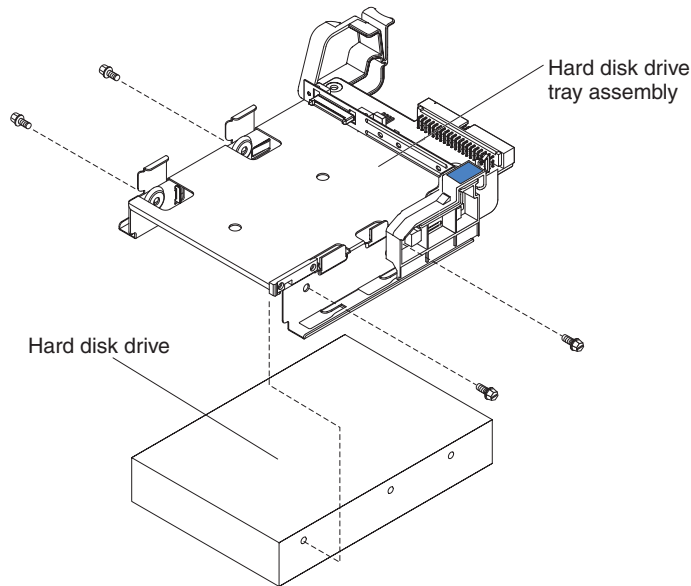

1. Read the safety information that begins on page vii and “Installation guidelines” on page 69.
2. Turn off the server and peripheral devices and disconnect all power cords and external cables; then, remove the server from the rack.
3. Remove the server cover (see “Removing the cover” on page 71).
4. Remove the CD or DVD drive from the server (see “Removing the CD or DVD drive” on page 77).
5. Remove the front hard disk drive cage from the server (see “Removing the front hard disk drive cage assembly” on page 94).
6. Disconnect the power cable and the signal cable from the hard disk drive.
7. Place the drive-cage assembly on a flat, static-protective surface.
8. Remove the four drive mounting screws from the sides of the drive cage and slide the drive out of the cage.
9. If you are instructed to return the drive, follow all packaging instructions, and use any packaging materials for shipping that are supplied to you.

Installing the front hard disk drive

Locate the documentation that comes with the hard disk drive and follow those instructions in addition to the instructions in this chapter.

To install the front hard disk drive, complete the following steps.

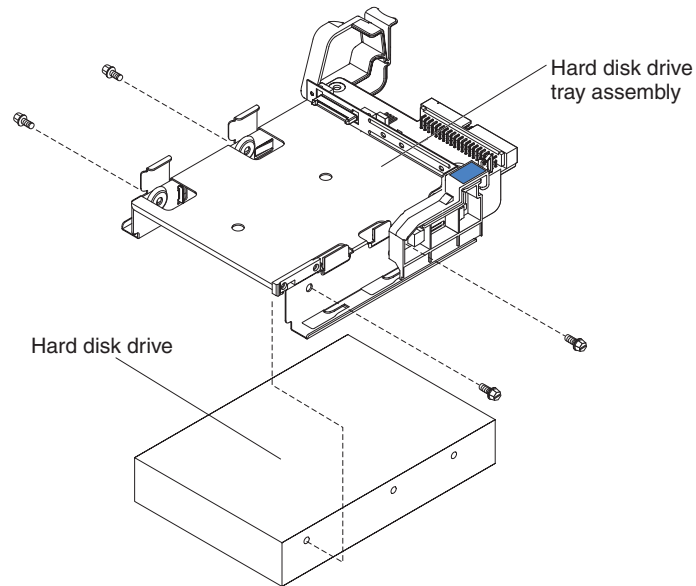

1. Read the safety information that begins on page vii and “Installation guidelines” on page 69.
2. Mount the drive in the front hard disk drive cage assembly, using the four mounting screws that you removed previously.
3. Connect the power cable and the signal cable to the drive.
4. Install the front hard disk drive cage assembly in the server (see “Installing the front hard disk drive cage assembly” on page 95).
5. Install the CD or DVD drive in the server (see “Installing the CD or DVD drive” on page 79).
6. Install the cover (see “Installing the cover” on page 71).
7. Slide the server into the rack.
8. Reconnect the power cords and any cables that you removed.
9. Turn on the peripheral devices and the server.
10. If you are instructed to return the hard disk drive, follow all packaging instructions, and use any packaging materials for shipping that are supplied to you.

Removing the rear hard disk drive

Locate the documentation that comes with the hard disk drive and follow those instructions in addition to the instructions in this section.

To remove the rear hard disk drive, complete the following steps.

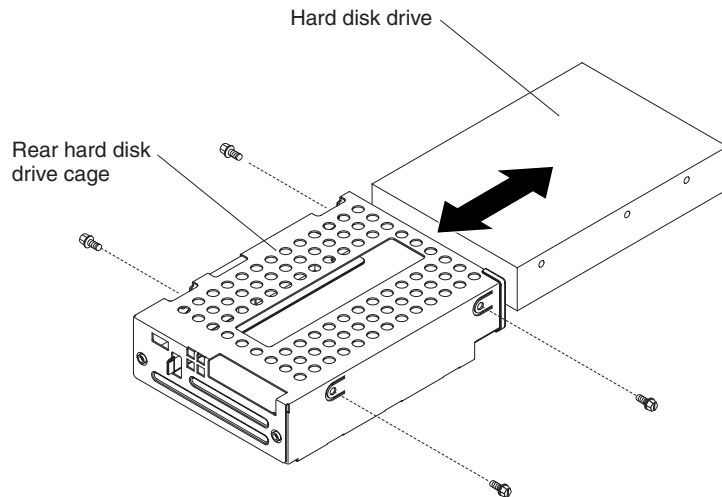

1. Read the safety information that begins on page vii and “Installation guidelines” on page 69.
2. Turn off the server and peripheral devices and disconnect all power cords and external cables; then, remove the server from the rack.
3. Remove the server cover (see “Removing the cover” on page 71).
4. Remove the hard disk drive cage assembly from the server (see “Removing the rear hard disk drive cage assembly” on page 96).
5. Disconnect the power cable and the signal cable from the hard disk drive.
6. Place the drive on a flat, static-protective surface.
7. Remove the four drive mounting screws from the sides of the drive cage and slide the drive out of the cage.
8. If you are instructed to return the drive, follow all packaging instructions, and use any packaging materials for shipping that are supplied to you.

Installing the rear hard disk drive

Locate the documentation that comes with the hard disk drive and follow those instructions in addition to the instructions in this chapter.

To install the rear hard disk drive, complete the following steps.

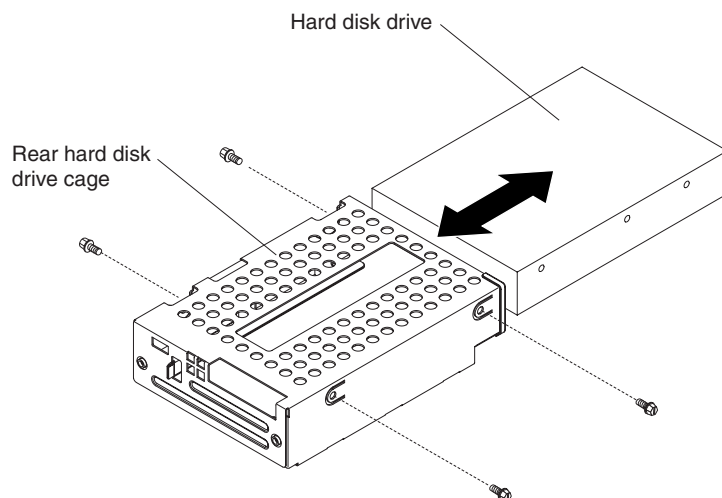

1. Read the safety information that begins on page vii and “Installation guidelines” on page 69.
2. Mount the drive in the rear hard disk drive cage assembly, using the four mounting screws that you removed previously.
3. Connect the power and signal cables to the drive.
4. Install the rear hard disk drive cage assembly in the server (see “Installing the rear hard disk drive cage assembly” on page 97).
5. Install the cover (see “Installing the cover” on page 71).
6. Slide the server into the rack.
7. Reconnect the power cords and any cables that you removed.
8. Turn on the peripheral devices and the server.

Removing and replacing FRUs

FRUs must be replaced or installed only by trained service technicians.

The illustrations in this document might differ slightly from the hardware.

Removing a microprocessor

Attention:

- Do not allow the thermal grease on the microprocessor and heat sink to come in contact with anything. Contact with any surface can compromise the thermal grease and the microprocessor socket.
- Use care when removing the microprocessor. Dropping the microprocessor during installation or removal can damage the contacts.
- Do not touch the microprocessor contacts; handle the microprocessor by the edges only. Contaminants on the microprocessor contacts, such as oil from your skin, can cause connection failures between the contacts and the socket.

To remove a microprocessor and heat sink, complete the following steps.

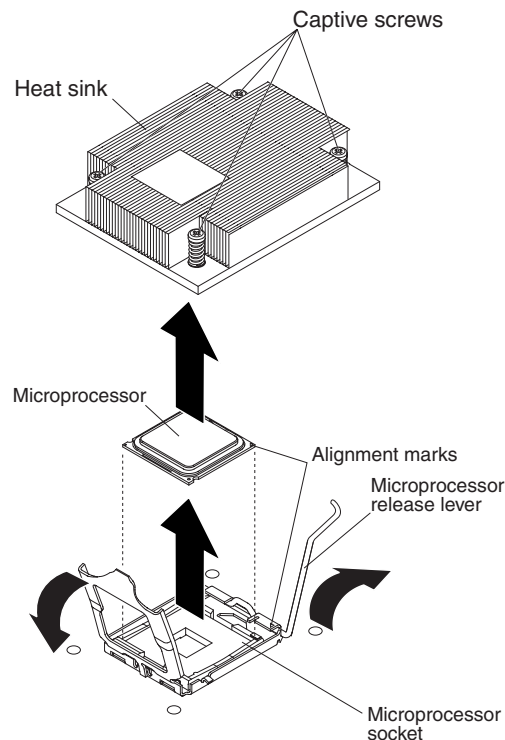

1. Read the safety information that begins on page vii and “Installation guidelines” on page 69.
2. Turn off the server and peripheral devices and disconnect all power cords and external cables; then, remove the server from the rack.
3. Remove the server cover. See “Removing the cover” on page 71.
4. Remove the heat sink. Loosen two captive screws on alternate sides of the heat sink fully before you loosen the other two captive screws (this helps to break the bond between the heat sink and the microprocessor). After the captive screws are loosened, remove the heat sink.

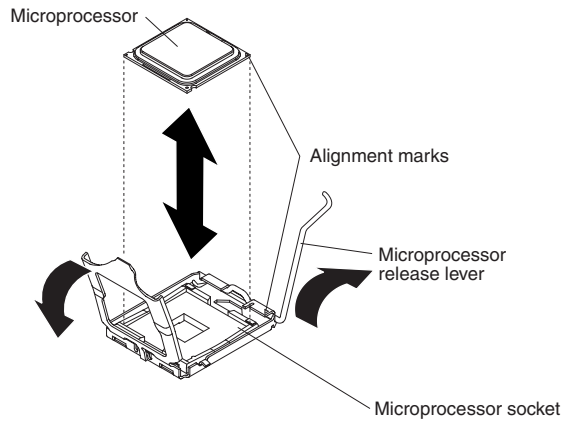

5. Open the microprocessor-release lever to the fully-open position.
6. Open the microprocessor bracket frame.
7. Carefully remove the microprocessor.
8. If you are instructed to return the microprocessor, follow all packaging instructions, and use any packaging materials for shipping that are supplied to you.

Installing a microprocessor

Attention: Do not touch the thermal grease on the bottom of the heat sink or set down the heat sink after the plastic cover is removed. Touching the thermal grease will contaminate it.

To install a microprocessor, complete the following steps:

1. Read the safety information that begins on page vii and “Installation guidelines” on page 69.

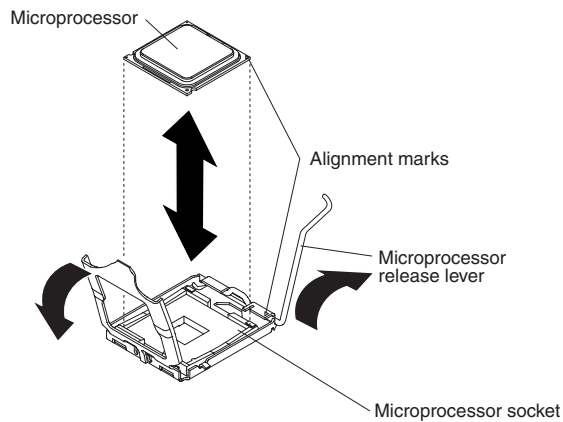

2. Align the microprocessor with the socket (note the alignment mark and the position of the notches); then, carefully place the microprocessor on the socket and close the microprocessor bracket frame.

Attention: Do not use excessive force when inserting the microprocessor into the socket.

Note: The microprocessor fits only one way on the socket.

3. Carefully close the release lever to secure the microprocessor in the socket.

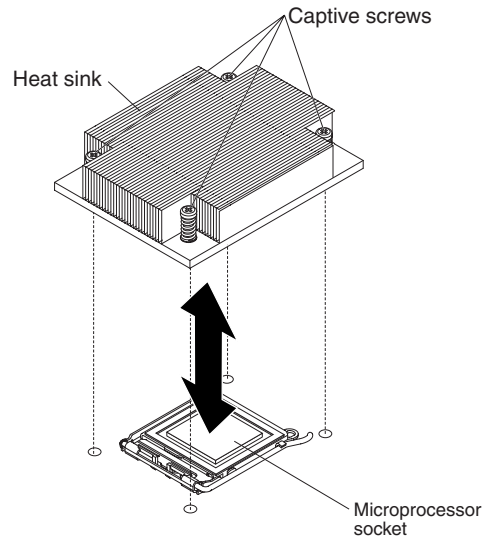

4. Install the heat sink on top of the microprocessor, and tighten the captive screws. Alternate among the screws on either side of the heat sink until they are snug, and then alternate again until they are tight, making sure that you do not overtighten any of them.
5. Install the cover (see “Installing the cover” on page 71).
6. Slide the server into the rack.
7. Reconnect the power cords and any cables that you removed.
8. Turn on the peripheral devices and the server.

Removing the system board

To remove the system board, complete the following steps.

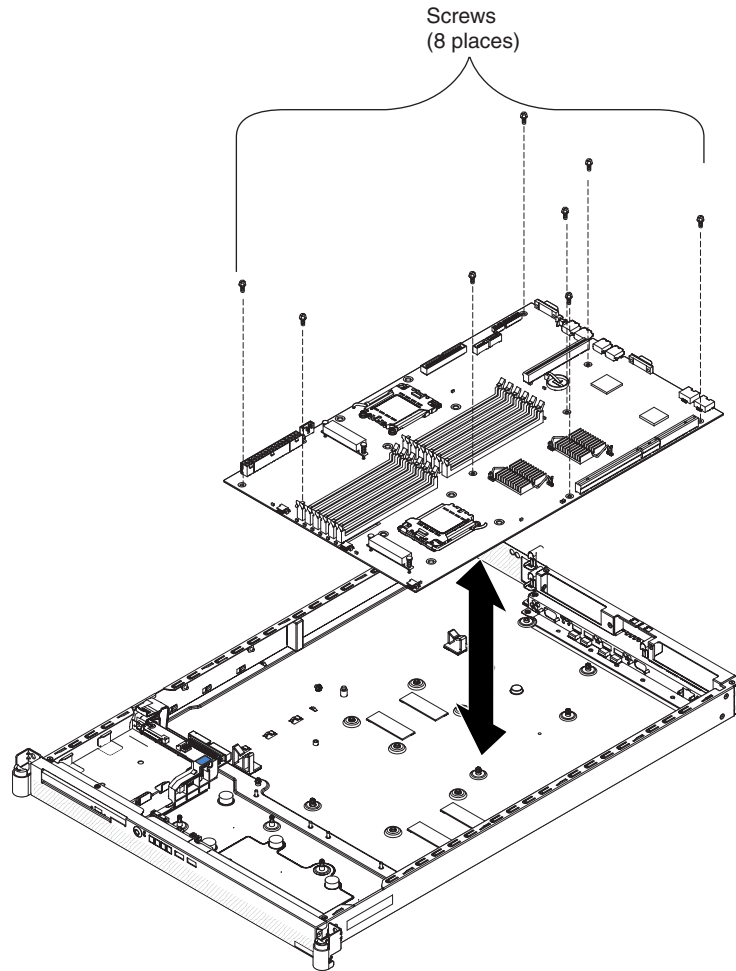

1. Read the safety information that begins on page vii and “Installation guidelines” on page 69.
2. Turn off the server and peripheral devices and disconnect all power cords and external cables; then, remove the server from the rack.
3. Remove the server cover. See “Removing the cover” on page 71.

Note: When you replace the system board, you must either update the server with the latest firmware or restore the pre-existing firmware that the customer provides on a diskette or CD image.

4. Remove all riser-card assemblies and adapters (see “Removing a riser-card assembly” on page 74).
5. Remove the two air baffles from the system board. See “Removing an air baffle” on page 72.
6. Disconnect all cables from the system board. Make a list of each cable as you disconnect it; you can then use this as a checklist when you install system board.
7. Remove all heat sinks and microprocessors, and set them aside on a static-protective surface for reinstallation (see “Removing a microprocessor” on page 102).

8. Remove the memory modules and set them aside on a static-protective surface for reinstallation (see “Removing a memory module (DIMM)” on page 80).

Note: Make a note of the location of each DIMM as you remove it, so that you can later reinstall it in the same socket.

9. Remove the eight screws that secure the system board to the chassis.
10. Remove the four hex standoff screws from the serial connector and the video connector at the rear of the server.
11. Slide the system board slightly toward the front of the server.
12. Lift up the left side (the side nearest to the power supply) of the system board.
13. Lift the rest of the system board and carefully remove it from the server, being careful not to disturb any surrounding components.
14. If you are instructed to return the system board, follow all packaging instructions, and use any packaging materials for shipping that are supplied to you.

Installing the system board

Note: When you reassemble the components in the server, be sure to route all cables carefully so that they are not exposed to excessive pressure.

To reinstall the system board, complete the following steps.

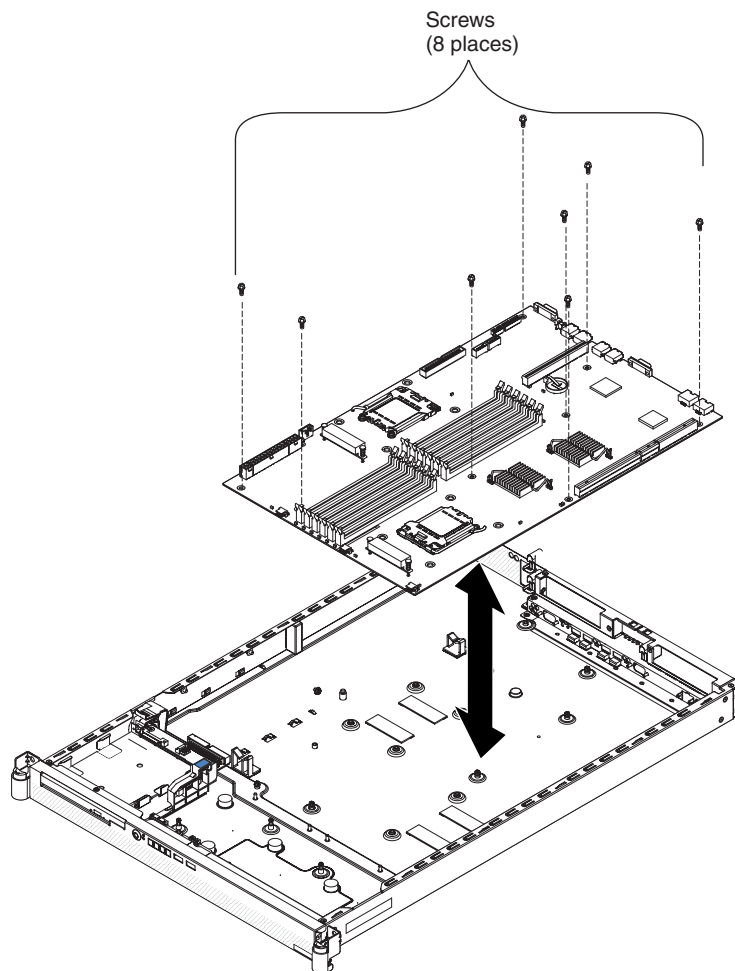

1. Read the safety information that begins on page vii and “Installation guidelines” on page 69.
2. Align the system board with the chassis and replace the eight screws that you removed.
3. Replace the microprocessor and microprocessor heat sink (see “Installing a microprocessor” on page 103).
4. Reconnect to the system board the cables that you disconnected in step 6 of “Removing the system board” on page 105.
5. Replace the DIMMs (see “Installing a memory module” on page 81).
6. Replace the air baffles (see “Installing an air baffle” on page 73).
7. Replace the riser-card assemblies and adapters, if any were installed (see “Installing a riser-card assembly” on page 75).
8. Replace the four hex standoff screws on the video connector and the serial connector at the rear of the server.
9. Install the cover (see “Installing the cover” on page 71).
10. Slide the server into the rack.
11. Reconnect the power cords and any cables that you removed.
12. Turn on the peripheral devices and the server.

Important: Perform the following updates:

- Update the UUID (see “Updating the UUID” on page 111).
- Update the DMI/SMBIOS (see “Updating the DMI/SMBIOS data” on page 111).

Chapter 5. Configuration information and instructions

This chapter provides information about updating the firmware and using the configuration utilities.

Updating the firmware

The firmware and software for the server is periodically updated and is available for download on the Web. Go to <http://www.ibm.com/servers/eserver/support/xseries/index.html> to check for the latest level of firmware, such as BIOS code, vital product data (VPD) code, device drivers, service processor firmware and diagnostic programs.

Important: To ensure proper server operation, be sure to update the baseboard management controller firmware before you update the BIOS code.

When you replace a device in the server, you might have to either update the server with the latest version of the firmware that is stored in memory on the device or restore the pre-existing firmware from a diskette or CD image.

- BIOS code is stored in ROM on the system board.
- BMC firmware is stored in ROM on the Baseboard Management Controller on the system board.
- Ethernet firmware is stored in ROM on the Ethernet controller.
- SATA firmware is stored in ROM on the integrated SATA controller.
- Major components contain vital product data (VPD) code. You can select to update the VPD code during the BIOS code update procedure.

Configuring the server

The *ServerGuide Setup and Installation* CD provides software setup tools and installation tools that are specifically designed for your IBM server. Use this CD during the initial installation of the server to configure basic hardware features and to simplify the operating-system installation.

In addition to the *ServerGuide Setup and Installation* CD, you can use the following configuration programs to customize the server hardware:

- Configuration/Setup Utility program
- SAS/SATA Configuration Utility program

For more information about these programs, see “Configuring the server” in the *User’s Guide* on the *IBM System x Documentation* CD.

Using the Configuration/Setup Utility program

The Configuration/Setup Utility program is part of the BIOS. You can use it to perform the following tasks:

- View configuration information
- View and change assignments for devices and I/O ports
- Set the date and time
- Set and change passwords
- View and clear the error log

Go to <http://www.ibm.com/servers/eserver/support/xseries/index.html> to check for the latest version of the BIOS code.

Starting the Configuration/Setup Utility program

To start the Configuration/Setup Utility program, complete the following steps:

1. Turn on the server.
2. When the message Press F1 for Setup appears, press F1. If an administrator password has been set, you must type the administrator password to access the full Configuration/Setup Utility menu.
3. Follow the instructions on the screen.

See the *User's Guide* on the IBM System x Documentation CD for more detailed information about the Configuration/Setup Utility program.

Configuring the Ethernet controller

The Ethernet controller is integrated on the system board. It provides an interface for connecting to a 10-Mbps, 100-Mbps, or 1-Gbps network and provides full-duplex (FDX) capability, which enables simultaneous transmission and reception of data on the network. If the Ethernet ports in the server support auto-negotiation, the controller detects the data-transfer rate (10BASE-T, 100BASE-TX, or 1000BASE-T) and duplex mode (full-duplex or half-duplex) of the network and automatically operates at that rate and mode.

You do not have to set any jumpers or configure the controller. However, you must install a device driver to enable the operating system to address the controller. For device drivers and information about configuring the Ethernet controller, see the *Broadcom NetXtreme Gigabit Ethernet Software CD* that comes with the server. For updated information about configuring the controller, see <http://www.ibm.com/servers/eserver/support/xseries/index.html>.

Updating the BMC firmware

Use the baseboard management controller firmware update utility program to download a baseboard management controller firmware update. This program updates the baseboard management controller firmware only and does not affect any device drivers.

Important: To ensure proper server operation, be sure to update the baseboard management controller firmware before you update the BIOS code.

To download the program, go to <http://www.ibm.com/servers/eserver/support/xseries/index.html>, select **System x3455** from the **Hardware** list, and click **Go**. Click the **Download** tab, and search for BMC software; then, copy the file Flash.exe to a firmware update CD or diskette.

If you are using a CD or diskette, complete the following steps.

1. Turn on the server.
2. If you are using a CD, insert the firmware update CD into the CD-RW/DVD drive.
3. If you are using a diskette, insert the firmware update diskette into the external USB diskette drive.
4. From a command line, type `flash -?` and press Enter.

Note: If the server does not start from the external USB diskette drive, use the Configuration/Setup Utility program to configure the external USB diskette drive as a startup device. (For information about the Configuration/Setup Utility program, see the *User's Guide* on the IBM System x Documentation CD.) Then, start again at step 1 on page 110 of this procedure.

If there is an error in updating the firmware, try the update again.

Updating the UUID

You must update the Universal Unique Identifier (UUID) when you replace the system board. To update the UUID, complete the following steps:

1. Copy the UUID utility (uuid.exe) from the BIOS flash diskette to a DOS bootable diskette.
2. Insert the diskette into an external USB diskette drive that is connected to the server.
3. Restart the server from the diskette.
4. At the a:\ prompt, type UUID /wr, and press Enter. The utility generates a random identifier.
5. Restart the server.

Updating the DMI/SMBIOS data

You must update the Desktop Management Interface (DMI) when you replace the system board. To update the DMI, complete the following steps:

1. Copy the DMI/SMBIOS utility (extrmdmi.exe) from the BIOS flash diskette to a DOS bootable diskette.
2. Insert the diskette into an external USB diskette drive that is connected to the server.
3. Restart the server from the diskette.
4. At the a:\ prompt, type extrmdmi .exe, and press Enter.
5. To change the machine type and model number, type mtm xxxxyyy, where xxxx is the model type and yyy is the model number; then, press Enter.
6. To change the serial number, type sn zzzzzzz, where zzzzzzz is the serial number; then, press Enter.
7. To change the asset tag, type asset aaaaaaaaaaaaaaaaaaaaaaaaaaaaaaaaaa, where aaaaaaaaaaaaaaaaaaaaaaaaaaaaaaaaaa is the asset tag number; then, press Enter.
8. Restart the server.

Appendix A. Getting help and technical assistance

If you need help, service, or technical assistance or just want more information about IBM products, you will find a wide variety of sources available from IBM to assist you. This appendix contains information about where to go for additional information about IBM and IBM products, what to do if you experience a problem with your system or optional device, and whom to call for service, if it is necessary.

Before you call

Before you call, make sure that you have taken these steps to try to solve the problem yourself:

- Check all cables to make sure that they are connected.
- Check the power switches to make sure that the system and any optional devices are turned on.
- Use the troubleshooting information in your system documentation, and use the diagnostic tools that come with your system. Information about diagnostic tools is in the *Hardware Maintenance Manual and Troubleshooting Guide* or *Problem Determination and Service Guide* on the IBM Documentation CD that comes with your system.

Note: For some IntelliStation models, the *Hardware Maintenance Manual and Troubleshooting Guide* is available only from the IBM support Web site.

- Go to the IBM support Web site at <http://www.ibm.com/servers/eserver/support/xseries/index.html> to check for technical information, hints, tips, and new device drivers or to submit a request for information.

You can solve many problems without outside assistance by following the troubleshooting procedures that IBM provides in the online help or in the documentation that is provided with your IBM product. The documentation that comes with IBM systems also describes the diagnostic tests that you can perform. Most systems, operating systems, and programs come with documentation that contains troubleshooting procedures and explanations of error messages and error codes. If you suspect a software problem, see the documentation for the operating system or program.

Using the documentation

Information about your IBM system and preinstalled software, if any, or optional device is available in the documentation that comes with the product. That documentation can include printed documents, online documents, readme files, and help files. See the troubleshooting information in your system documentation for instructions for using the diagnostic programs. The troubleshooting information or the diagnostic programs might tell you that you need additional or updated device drivers or other software. IBM maintains pages on the World Wide Web where you can get the latest technical information and download device drivers and updates. To access these pages, go to <http://www.ibm.com/servers/eserver/support/xseries/index.html> and follow the instructions. Also, some documents are available through the IBM Publications Center at <http://www.ibm.com/shop/publications/order/>.

Getting help and information from the World Wide Web

On the World Wide Web, the IBM Web site has up-to-date information about IBM systems, optional devices, services, and support. The address for IBM System x and xSeries information is <http://www.ibm.com/systems/x/>. The address for IBM IntelliStation information is <http://www.ibm.com/intellistation/>.

You can find service information for IBM systems and optional devices at <http://www.ibm.com/servers/eserver/support/xseries/index.html>.

Software service and support

Through IBM Support Line, you can get telephone assistance, for a fee, with usage, configuration, and software problems with System x and xSeries servers, BladeCenter products, IntelliStation workstations, and appliances. For information about which products are supported by Support Line in your country or region, see <http://www.ibm.com/services/sl/products/>.

For more information about Support Line and other IBM services, see <http://www.ibm.com/services/>, or see <http://www.ibm.com/planetwide/> for support telephone numbers. In the U.S. and Canada, call 1-800-IBM-SERV (1-800-426-7378).

Hardware service and support

Important: When you call for service, you will be asked to provide the four-digit machine type of your system, which is 7984 or 7986.

You can receive hardware service through IBM Services or through your IBM reseller, if your reseller is authorized by IBM to provide warranty service. See <http://www.ibm.com/planetwide/> for support telephone numbers, or in the U.S. and Canada, call 1-800-IBM-SERV (1-800-426-7378).

In the U.S. and Canada, hardware service and support is available 24 hours a day, 7 days a week. In the U.K., these services are available Monday through Friday, from 9 a.m. to 6 p.m.

Appendix B. Notices

This information was developed for products and services offered in the U.S.A.

IBM may not offer the products, services, or features discussed in this document in other countries. Consult your local IBM representative for information on the products and services currently available in your area. Any reference to an IBM product, program, or service is not intended to state or imply that only that IBM product, program, or service may be used. Any functionally equivalent product, program, or service that does not infringe any IBM intellectual property right may be used instead. However, it is the user's responsibility to evaluate and verify the operation of any non-IBM product, program, or service.

IBM may have patents or pending patent applications covering subject matter described in this document. The furnishing of this document does not give you any license to these patents. You can send license inquiries, in writing, to:

*IBM Director of Licensing
IBM Corporation
North Castle Drive
Armonk, NY 10504-1785
U.S.A.*

INTERNATIONAL BUSINESS MACHINES CORPORATION PROVIDES THIS PUBLICATION "AS IS" WITHOUT WARRANTY OF ANY KIND, EITHER EXPRESS OR IMPLIED, INCLUDING, BUT NOT LIMITED TO, THE IMPLIED WARRANTIES OF NON-INFRINGEMENT, MERCHANTABILITY OR FITNESS FOR A PARTICULAR PURPOSE. Some states do not allow disclaimer of express or implied warranties in certain transactions, therefore, this statement may not apply to you.

This information could include technical inaccuracies or typographical errors. Changes are periodically made to the information herein; these changes will be incorporated in new editions of the publication. IBM may make improvements and/or changes in the product(s) and/or the program(s) described in this publication at any time without notice.

Any references in this information to non-IBM Web sites are provided for convenience only and do not in any manner serve as an endorsement of those Web sites. The materials at those Web sites are not part of the materials for this IBM product, and use of those Web sites is at your own risk.

IBM may use or distribute any of the information you supply in any way it believes appropriate without incurring any obligation to you.

Trademarks

The following terms are trademarks of International Business Machines Corporation in the United States, other countries, or both:

Active Memory	IBM (logo)	Tivoli
Active PCI	IntelliStation	Tivoli Enterprise
Active PCI-X	NetBAY	Update Connector
Alert on LAN	Netfinity	Wake on LAN
BladeCenter	Predictive Failure Analysis	XA-32

Chipkill	ServeRAID	XA-64
FlashCopy	ServerGuide	X-Architecture
IBM	ServerProven	XpandOnDemand
TechConnect	System x	xSeries

Intel, Intel Xeon, Itanium, and Pentium are trademarks or registered trademarks of Intel Corporation or its subsidiaries in the United States and other countries.

Microsoft, Windows, and Windows NT are trademarks of Microsoft Corporation in the United States, other countries, or both.

UNIX is a registered trademark of The Open Group in the United States and other countries.

Java and all Java-based trademarks and logos are trademarks of Sun Microsystems, Inc. in the United States, other countries, or both.

Adaptec and HostRAID are trademarks of Adaptec, Inc., in the United States, other countries, or both.

Linux is a trademark of Linus Torvalds in the United States, other countries, or both.

Red Hat, the Red Hat “Shadow Man” logo, and all Red Hat-based trademarks and logos are trademarks or registered trademarks of Red Hat, Inc., in the United States and other countries.

Other company, product, or service names may be trademarks or service marks of others.

Important notes

Processor speeds indicate the internal clock speed of the microprocessor; other factors also affect application performance.

CD-ROM drive speeds list the variable read rate. Actual speeds vary and are often less than the maximum possible.

When referring to processor storage, real and virtual storage, or channel volume, KB stands for approximately 1000 bytes, MB stands for approximately 1 000 000 bytes, and GB stands for approximately 1 000 000 000 bytes.

When referring to hard disk drive capacity or communications volume, MB stands for 1 000 000 bytes, and GB stands for 1 000 000 000 bytes. Total user-accessible capacity may vary depending on operating environments.

Maximum internal hard disk drive capacities assume the replacement of any standard hard disk drives and population of all hard disk drive bays with the largest currently supported drives available from IBM.

Maximum memory may require replacement of the standard memory with an optional memory module.

IBM makes no representation or warranties regarding non-IBM products and services that are ServerProven[®], including but not limited to the implied warranties of merchantability and fitness for a particular purpose. These products are offered and warranted solely by third parties.

IBM makes no representations or warranties with respect to non-IBM products. Support (if any) for the non-IBM products is provided by the third party, not IBM.

Some software may differ from its retail version (if available), and may not include user manuals or all program functionality.

Product recycling and disposal

This unit must be recycled or discarded according to applicable local and national regulations. IBM encourages owners of information technology (IT) equipment to responsibly recycle their equipment when it is no longer needed. IBM offers a variety of product return programs and services in several countries to assist equipment owners in recycling their IT products. Information on IBM product recycling offerings can be found on IBM's Internet site at <http://www.ibm.com/ibm/environment/products/prp.shtml>

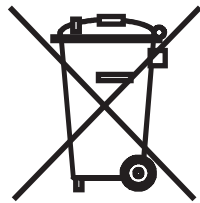

Notice: This mark applies only to countries within the European Union (EU) and Norway.

This appliance is labeled in accordance with European Directive 2002/96/EC concerning waste electrical and electronic equipment (WEEE). The Directive determines the framework for the return and recycling of used appliances as applicable throughout the European Union. This label is applied to various products to indicate that the product is not to be thrown away, but rather reclaimed upon end of life per this Directive.

注意: このマークは EU 諸国およびノルウェーにおいてのみ適用されます。

この機器には、EU 諸国に対する廃電気電子機器指令 2002/96/EC(WEEE) のラベルが貼られています。この指令は、EU 諸国に適用する使用済み機器の回収とリサイクルの骨子を定めています。このラベルは、使用済みになった時に指令に従って適正な処理をする必要があることを知らせるために種々の製品に貼られています。

Remarque: Cette marque s'applique uniquement aux pays de l'Union Européenne et à la Norvège.

L'étiquette du système respecte la Directive européenne 2002/96/EC en matière de Déchets des Equipements Electriques et Electroniques (DEEE), qui détermine les dispositions de retour et de recyclage applicables aux systèmes utilisés à travers l'Union européenne. Conformément à la directive, ladite étiquette précise que le produit sur lequel elle est apposée ne doit pas être jeté mais être récupéré en fin de vie.

In accordance with the European WEEE Directive, electrical and electronic equipment (EEE) is to be collected separately and to be reused, recycled, or recovered at end of life. Users of EEE with the WEEE marking per Annex IV of the WEEE Directive, as shown above, must not dispose of end of life EEE as unsorted municipal waste, but use the collection framework available to customers for the return, recycling, and recovery of WEEE. Customer participation is important to minimize any potential effects of EEE on the environment and human health due to the potential presence of hazardous substances in EEE. For proper collection and treatment, contact your local IBM representative.

Battery return program

This product may contain a sealed lead acid, nickel cadmium, nickel metal hydride, lithium, or lithium ion battery. Consult your user manual or service manual for specific battery information. The battery must be recycled or disposed of properly. Recycling facilities may not be available in your area. For information on disposal of batteries outside the United States, go to <http://www.ibm.com/ibm/environment/products/batteryrecycle.shtml> or contact your local waste disposal facility.

In the United States, IBM has established a return process for reuse, recycling, or proper disposal of used IBM sealed lead acid, nickel cadmium, nickel metal hydride, and battery packs from IBM equipment. For information on proper disposal of these batteries, contact IBM at 1-800-426-4333. Have the IBM part number listed on the battery available prior to your call.

In the Netherlands, the following applies.



For Taiwan: Please recycle batteries.



For California: Perchlorate material – special handling may apply. See <http://www.dtsc.ca.gov/hazardouswaste/perchlorate/>.

The foregoing notice is provided in accordance with California Code of Regulations Title 22, Division 4.5 Chapter 33. Best Management Practices for Perchlorate Materials. This product/part may include a lithium manganese dioxide battery which contains a perchlorate substance.

Electronic emission notices

Federal Communications Commission (FCC) statement

Note: This equipment has been tested and found to comply with the limits for a Class A digital device, pursuant to Part 15 of the FCC Rules. These limits are designed to provide reasonable protection against harmful interference when the equipment is operated in a commercial environment. This equipment generates, uses, and can radiate radio frequency energy and, if not installed and used in accordance with the instruction manual, may cause harmful interference to radio communications. Operation of this equipment in a residential area is likely to cause harmful interference, in which case the user will be required to correct the interference at his own expense.

Properly shielded and grounded cables and connectors must be used in order to meet FCC emission limits. IBM is not responsible for any radio or television interference caused by using other than recommended cables and connectors or by unauthorized changes or modifications to this equipment. Unauthorized changes or modifications could void the user's authority to operate the equipment.

This device complies with Part 15 of the FCC Rules. Operation is subject to the following two conditions: (1) this device may not cause harmful interference, and (2) this device must accept any interference received, including interference that may cause undesired operation.

Industry Canada Class A emission compliance statement

This Class A digital apparatus complies with Canadian ICES-003.

Avis de conformité à la réglementation d'Industrie Canada

Cet appareil numérique de la classe A est conforme à la norme NMB-003 du Canada.

Australia and New Zealand Class A statement

Attention: This is a Class A product. In a domestic environment this product may cause radio interference in which case the user may be required to take adequate measures.

United Kingdom telecommunications safety requirement

Notice to Customers

This apparatus is approved under approval number NS/G/1234/J/100003 for indirect connection to public telecommunication systems in the United Kingdom.

European Union EMC Directive conformance statement

This product is in conformity with the protection requirements of EU Council Directive 89/336/EEC on the approximation of the laws of the Member States relating to electromagnetic compatibility. IBM cannot accept responsibility for any failure to satisfy the protection requirements resulting from a nonrecommended modification of the product, including the fitting of non-IBM option cards.

This product has been tested and found to comply with the limits for Class A Information Technology Equipment according to CISPR 22/European Standard EN

55022. The limits for Class A equipment were derived for commercial and industrial environments to provide reasonable protection against interference with licensed communication equipment.

Attention: This is a Class A product. In a domestic environment this product may cause radio interference in which case the user may be required to take adequate measures.

Taiwanese Class A warning statement

警告使用者：
這是甲類的資訊產品，在居住的環境中使用時，可能會造成射頻干擾，在這種情況下，使用者會被要求採取某些適當的對策。

Chinese Class A warning statement

聲 明
此為 A 級產品。在生活環境中，該產品可能會造成無線電干擾。在這種情況下，可能需要用戶對其干擾採取切实可行的措施。

Japanese Voluntary Control Council for Interference (VCCI) statement

この装置は、情報処理装置等電波障害自主規制協議会（VCCI）の基準に基づくクラスA情報技術装置です。この装置を家庭環境で使用すると電波妨害を引き起こすことがあります。この場合には使用者が適切な対策を講ずるよう要求されることがあります。

Index

A

- ac power LED 7, 44
- acoustical noise emissions 4
- activity LEDs
 - CD drive 5
 - DVD drive 5
 - hard disk drive 6
 - local area network (LAN), Ethernet 7
- adapter
 - HTX 76
 - installing 77
 - PCI Express bus 76
 - replacing 76
- administrator password
 - resetting 57
- air baffle
 - replacing 72
- attention notices 2

B

- battery
 - replacing 84
- beep codes 15
- BIOS
 - restoring 57
 - updating 51, 109
- BMC
 - firmware, updating 110
 - heartbeat LED 13
 - system event log (SEL) 20, 53
- boot block
 - recovery 51

C

- cable connectors
 - Ethernet 7
 - power 7
 - serial 7
 - Universal Serial Bus (USB) 6, 7
 - video 7
- caution statements 2
- CD drive
 - activity LED 5
 - backplane, replacing 92
 - CD-eject button 5
 - problems 30
 - replacing 77
 - specifications 3
- CD-eject button 5
- checkout procedure 28
- Class A electronic emission notice 119
- clearing CMOS 57
- CMOS
 - clearing 57

- components
 - list of 65
- configuration
 - Configuration/Setup Utility 109
 - Ethernet controllers 110
 - ServerGuide Setup and Installation CD 109
- Configuration/Setup Utility program 109
- configuring hardware 109
- configuring your server 109
- connector
 - Ethernet 7
 - local area network (LAN) 7
 - operator information panel 5, 6
 - power cord 7
 - serial 7
 - Universal Serial Bus (USB) 6, 7
 - video 7
- connectors 8
 - external 11
 - internal 7
 - option, on system board 7
- controller
 - Ethernet
 - configuring 110
- controls
 - front 5
 - operator information panel 5, 6
 - rear 6, 7
- cooling 3
- cover
 - installing 71
 - replacing 71
- CRUs, replacing
 - adapter 76
 - air baffle 73
 - battery 84
 - CD drive backplane 92
 - CD or DVD drive 77
 - cover 71
 - DIMMs 80
 - hard disk drive 97, 99
 - memory 80
 - operator information panel 90
 - riser card assembly 74
- customer replaceable units (CRUs) 65

D

- danger statements 2
- dc power LED 7, 44
- diagnostic
 - error codes 47, 53
 - programs 45
 - programs, updating 109
 - test log, viewing 46
 - text message format 46
 - tools, overview 15

- DIMMs
 - installing 82
 - replacing 80
- disk drive cage
 - replacing 94
- diskette drive
 - USB 6
- display problems 36
- dual inline memory module (DIMM)
 - coordination with microprocessors 81
 - installation sequence
 - one microprocessor 81
 - two microprocessors 81
- DVD drive
 - activity LED 5
 - DVD-eject button 5
 - problems 30
 - replacing 77
- DVD-eject button 5

E

- electrical input specifications 4
- electronic emission Class A notice 119
- environment
 - air temperature 4
 - humidity 4
- error codes and messages
 - beep 15
 - diagnostic 47, 53
 - POST/BIOS 21
- error LEDs
 - power supply 44
 - system board 42
- error logs
 - BMC 20
 - clearing 20
 - POST 20
 - system error 20
 - viewing 20
- error symptoms
 - CD or DVD drive 30
 - general 31
 - hard disk drive 32
 - intermittent 32
 - keyboard, USB 33
 - memory 34
 - microprocessor 35
 - monitor 36
 - mouse, USB 33
 - optional devices 38
 - pointing device, USB 33
 - power 39
 - serial port 40
 - ServerGuide 40
 - software 41
 - USB device 41
- Ethernet
 - connector 7
 - controller
 - configuring 110

- Ethernet (*continued*)
 - controller (*continued*)
 - troubleshooting 59
 - LAN activity LEDs 7
 - link LED 7
- expansion slot
 - specifications 3

F

- fan
 - replacing 83, 84
- FCC Class A notice 119
- features
 - server 3
- field replaceable units (FRUs) 65
- firmware, updating 109
 - BMC 110
- front view 5
- FRUs
 - list of 69
 - replacing 69

G

- Gigabit Ethernet connectors 7

H

- handling
 - static-sensitive devices 70
- hard disk drive
 - activity LED 6
 - installing 98, 100
 - problems 32
 - replacing 97, 99
- heat output specifications 4
- heat sink
 - replacing 104
- HTX
 - riser card 7

I

- IBM service 60
- important notices 2
- input/output connectors 5, 6
- installation sequence
 - DIMMs
 - one microprocessor 81
 - two microprocessors 81
- installing
 - adapters 77
 - air baffle 73
 - battery 85
 - CD or DVD drive 79
 - CD-RW/DVD backplane 93
 - cover 71
 - fan 84
 - heat sink 104

- installing (*continued*)
 - memory 82
 - microprocessor 103
 - operator information panel 91
 - riser card assembly 75
 - system board 106
- integrated functions 3
- intermittent problems 32
- internal connectors 7

J

- jumpers 9

L

- LEDs
 - ac power 7, 44
 - activity 7
 - BMC heartbeat 13
 - CD drive activity 5
 - dc power 7, 44
 - DVD drive activity 5
 - error 13
 - front 5
 - hard disk drive activity 6
 - light path power 13
 - link 7
 - locator 6, 7
 - operator information panel 5, 6
 - power 6
 - rear 6
 - system board 12
 - system board, error 42
 - system error 6
 - system-locator 13
 - VRD error 13
- light path button 8
- light path power LED 13
- link LED 7
- local area network (LAN)
 - activity LEDs, Ethernet 7
 - connectors 7
 - link LEDs 7
- locator LED 6, 7
- log
 - BMC system event (SEL) 20, 53
 - POST errors 20
 - system event/error 20

M

- memory
 - installing 82
 - problems 34
 - replacing 80
 - specifications 3
- messages
 - diagnostic 45
- microprocessor
 - coordination with DIMMs 81

- microprocessor (*continued*)
 - installing 103
 - problems 35
 - replacing 102
 - requirements 81
 - reseating 53
 - specifications 3
- monitor problems 36
- mouse problems 34

N

- Nonmaskable interrupt (NMI) switch 7
- notes, defined 2
- notices
 - electronic emission 119
 - FCC, Class A 119
 - important notes 116
- notices and statements, defined 2

O

- online publications 2
- operator information panel
 - connector 5, 6
 - controls 5, 6
 - installing 91
 - LEDs 5, 6
 - replacing 90
 - switches and connectors 8
- option connectors 7
- optional device problems 38

P

- parts listing 65
- passwords
 - resetting 57
- PCI Express
 - riser cards 7
- pointing device problems 34
- ports
 - Ethernet 7
 - serial 7
 - USB 6, 7
 - video 7
- POST
 - beep codes 15
 - error codes 21
 - error logging 20
- power
 - cord connector 7
 - LED 6
- power cords 66
- power problems 39, 58
- power supply
 - error LEDs 44
 - LEDs 7
 - replacing 87
 - specifications 3
- power-control button 5

- power-control-button shield 5
- power-on password
 - resetting 57
- problem isolation tables 30
- problems
 - CD or DVD drive 30
 - Ethernet controller 59
 - hard disk drive 32
 - intermittent 32
 - keyboard 33
 - memory 34
 - microprocessor 35
 - monitor 36
 - optional devices 38
 - POST/BIOS 21
 - power 39, 58
 - serial port 40
 - software 41
 - undetermined 60
 - USB device 41
 - video 36
- publications 1

R

- rack release latch 5
- rear view 6
- recovering, BIOS 51
- release latch, rack 5
- replacement parts 65
- replacing
 - adapter 76
 - air baffle 72
 - battery 84, 85
 - CD drive backplane 92
 - CD or DVD drive 77
 - cover 71
 - DIMM 80
 - disk drive cage 94
 - fan 83, 84
 - hard disk drive 97, 99
 - microprocessor 102
 - operator information panel 90
 - power supply 87
 - riser card assembly 74
 - system board 105
- reseating the microprocessor 53
- reset button 6
- resetting
 - passwords 57
- riser card
 - connector location 7
 - installing 75
 - removing 74

S

- serial connector 7
- serial port problems 40
- server replaceable units 65

- ServerGuide
 - Setup and Installation CD 109
- service
 - calling for 60
 - hardware 114
- settings
 - CMOS, clearing 57
- size, server 3
- software problems 41
- specifications 3
- statements and notices, defined 2
- static-sensitive devices
 - handling 70
- status LEDs
 - Ethernet 7
 - server 6
- switch
 - light path button 8
 - nonmaskable interrupt (NMI) 7
 - power 5
- switches and jumpers 8, 9
- system board
 - error LEDs 12
 - external connectors 11
 - internal connectors 7
 - jumper blocks 9
 - replacing 105
 - switches and jumpers 9
- system cooling 3
- system event log, BMC 20, 53
- system event/error log 20
- system-error LED 6
- system-locator LED 6, 7, 13

T

- test log, viewing 46
- tools, diagnostic 15
- trademarks 115
- transmit/receive LAN activity LEDs 7

U

- undetermined problems 60
- United States electronic emission Class A notice 119
- United States FCC Class A notice 119
- Universal Serial Bus (USB)
 - connectors 6, 7
 - problems 41
 - requirements 6
 - specifications 3
- updating firmware 109
 - BMC 110
- using
 - Configuration/Setup Utility 109
 - Ethernet controllers 110

V

- video
 - connector 7

video (*continued*)
 controller specifications 3
video problems 36
VRD error LED 13



Part Number: 42D2185

Printed in USA

(1P) P/N: 42D2185

