

Service
Service
Service



Service Manual

COMPACT
disc
DIGITAL AUDIO

CONTENTS

- 1 Explanation subdivision and table of contents per page
- 2 Controls and technical specifications
- 3 Servicing hints
- 4 Measurements and adjustments
- 5 Exploded views and parts lists of mechanical components
- 6 Block diagram, circuit diagrams, PCB data, parts lists of electrical components and wiring diagram
- 7 Changes
- 8 Additional information

For repair of the CD mechanism refer to Service Manual CDM-2, version 0500.

Safety regulations require that the set be restored to its original condition and that parts which are identical with those specified be used.

**CLASS 1
LASER PRODUCT**

3122 110 03420

Documentation Technique Service Dokumentation Documentazione di Servizio Huolto-Ohje Manual de Servicio Manual de Servicio



Subject to modification
(GB) 4822 725 21605
Printed in The Netherlands
© Copyright reserved

PHILIPS

Published by Service
Consumer Electronics

CS 11 055



1. EXPLANATION ON THE LAYOUT OF THE DOCUMENTATION

The documentation consists of chapters.
The number of the chapter is indicated by the first digit of the page number.
The second digit of the page number is the sequence numbering.

If modifications or supplements require new supplementary or replacement pages, the page number is extended with a third part:

A digit behind the page number indicates that it concerns a supplementary page.
A replacement page is indicated by a letter behind the page number.

Example

3-6	is page 6 of chapter 3
3-6-1	is a supplementary page behind page 3-6
3-6-a	is the replacement page of page 3-6 (so page 3-6 can be removed from the documentation).

TABLE OF CONTENTS PER PAGE

Chapter	Page	Contents
1	1-1	Explanation of the subdivision of the documentation Table of contents per page
2	2-1	Controls
	2-2	Technical specification
3	3-1	Servicing hints
	3-2	Disassembly of top cover Servicing of front panel Servicing of tray mechanism Disassembly of CDM Servicing of servo + decoder panel Replacement of transformer fuse
4	4-1	Electrical measurements and adjustments General checkpoints
	4-2	General checkpoints
	4-3	Detailed measuring method
	4-4	Detailed measuring method
	4-5	Detailed measuring method
	4-6	Detailed measuring method
	4-7	Detailed measuring method
5	5-1	Exploded view tray mechanism Partslist of mechanical components
	5-2	Exploded view of cabinet + parts list of cabinet components
6	6-1	Block diagram
	6-2	Circuit diagram of the servo
	6-3	Circuit diagram of the power supply and Drawing of the servo + decoder panel
	6-4	Drawing of the servo + decoder panel
	6-5	Circuit diagram of decoder 1
	6-6	Drawing of the control and display panel and its circuit diagram
	6-7	Circuit diagram of decoder 2
	6-8	Wiring diagram
	6-9	Electrical partslist Partslist lead-less components
	6-10	Survey standard symbols

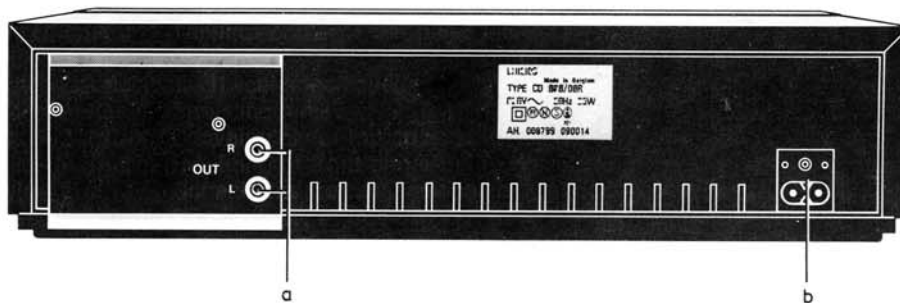
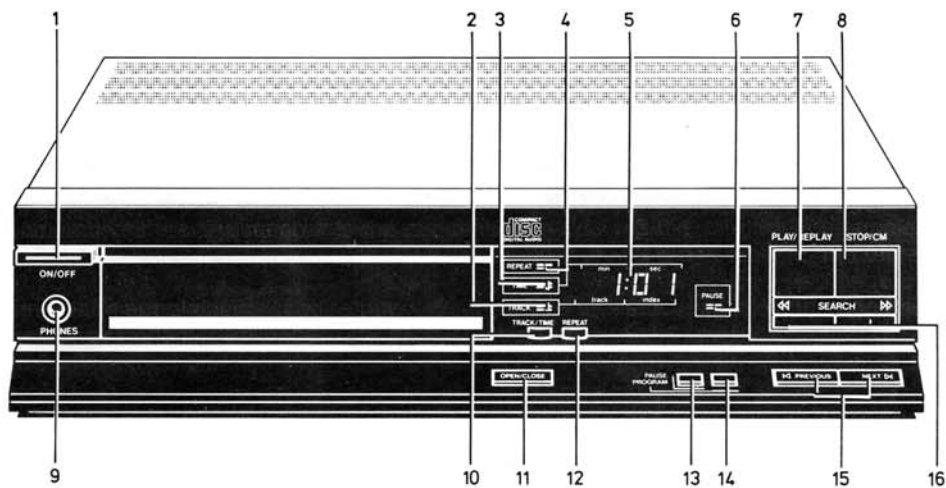

42 454 B12

2. CONTROLS

- 1 "ON/OFF" key: for switching the player on and off.
- 2 Track Led: lights during display of track numbers.
- 3 Time Led: lights during display of playing time.
- 4 Repeat Led: lights when you press the "REPEAT" key.
- 5 Display: functions as on/off indicator; gives information about the number of tracks on the disc, the playing time, the progress of play and particular functions of the player, and signals any faults occurring during operation or programming.
- 6 Pause Led lights when you press the "PAUSE" key.
- 7 "PLAY/REPLAY" key: for starting play ("PLAY") and returning to the beginning of a track ("REPLAY").
- 8 "STOP/CM" key: for stopping play during playback ("STOP") and for erasing a programme (CM = Clear Memory).
- 9 "PHONES" socket: for the connection of a headphone for listening to discs without using an amplifier.
- 10 "TRACK/TIME" key: for switching from track number to playing time indication and vice-versa.
- 11 "OPEN/CLOSE" key: for opening and closing the disc tray.
- 12 "REPEAT" key: for repeating a disc or a programme.
- 13 "PAUSE" key: for holding play at the start of a track or passage and for interrupting play.
- 14 "PROGRAM" key: for storing the track numbers of a programme and producing the display of the programme stored.
- 15 "PREVIOUS/NEXT" keys: for indicating the track number you want to begin with, and selecting track numbers when compiling a programme (<< from high to low and >> from low to high); also for returning to a previous track number or moving on to a later one during play.
- 16 "<< SEARCH >>" keys: for fast search to a particular passage (<< backwards, >> forwards).

- a. Out: for the signal output cable to the amplifier.
- b. Connections for the mains lead.

TECHNICAL SPECIFICATION

- System : Compact Disc Digital Audio system
- Mainsvoltages : 110 V, 127 V, 220 V, 240 V
± 10% (to be changed by transformer connections)
- Mains frequencies : 50-60 Hz (no adaption required)
- Power consumption : 14 W
- Frequency range : 2 Hz + 20 kHz ± 0,05 dB
- Output voltage : max. 2 V_{rms}/≥10 kOhms
- Output impedance : 200 Ohms
- S/N ratio : ≥96 dB
- Chanell separation : ≥93 dB
- Total harmonic distortion : ≤0,003% (-90 dB)
- Intermodulation distortion : ≤0,003% (-90 dB)
- De-emphasis : 0 or 15/50 μs (switched by the subcode on the disc)
- Dimensions wxhxd : 360 x 300 x 80 mm (tray closed)
360 x 425 x 80 mm (tray opened)
- Weight : approx. 2.9 kg
- Headphone
 - Output voltage : max. 5.6 Vrms
 - Output impedance : 150 Ω
 - Load impedance range: 8 Ω - 2 kΩ
 - Output power : 30 mW at 32 Ω

SERVICE AIDS

Audio test disc	4822 397 30085
Disc without errors + disc with DO errors, black spots and fingerprints	4822 397 30096
Torx screwdrivers	
Set (straight)	4822 395 50145
Set (square)	4822 395 50132
13th order filter	4822 395 30204
Service cable (4-pole)	4822 321 21284
Service cable (14-pole)	4822 322 40066
Service connector (14-pole)	4822 267 50676
Green LED CQYG II	5322 130 32182

3. SERVICING HINTS

ESD



All ICs and many other semi-conductors are susceptible to electrostatic discharges (ESD). Careless handling during repair can reduce life drastically.

When repairing, make sure that you are connected with the same potential as the mass of the set via a wrist wrap with resistance. Keep components and tools also at this potential.

The disc should always rest properly on the turntable. To achieve this a disc hold-down has been mounted in the cover.

When the cover has to be taken from the set for repair, a separate hold down should be used. Switch SK2 has to be interconnected. The set can be used normally.

In the set chip components have been applied. For disassembly and assembly of chip components see the figure below.

For measurements and adjustments it is possible to position the working mechanism outside the set.

To do this work the following service aids are available:

- Service cable (4-pole) 4822 321 21284
- Service flat cable (14-pole) 4822 322 40066
- Service connector (14-pole) 4822 267 50676

These two items should be used to assemble an extension cable between connector 11 and the flex cable of the CDM-2 unit.

Remark: The service cable should be assembled as follows (see drawing MDA 00311).

The 14-pole connector should be soldered as indicated in the drawing. Please remove the blue tape of the rear of the service flat cable-end which has to be connected to connector 11.

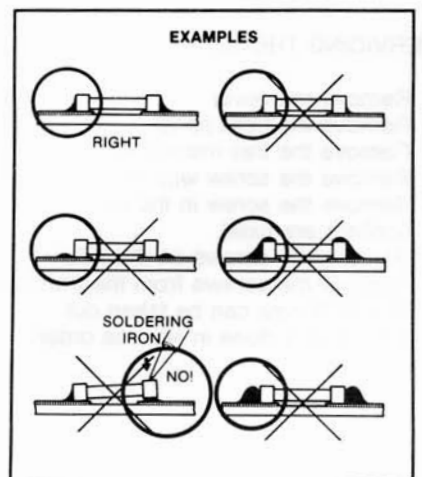
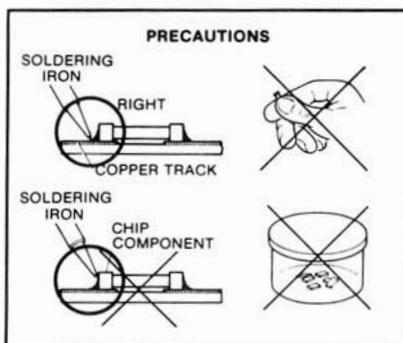
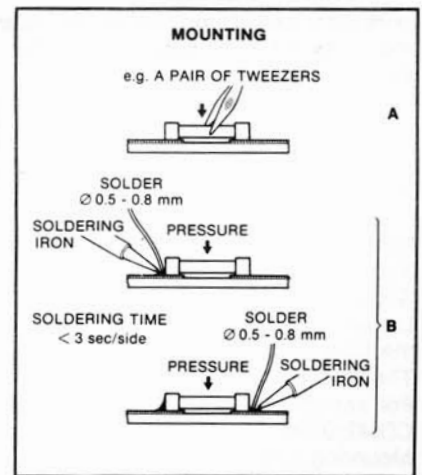
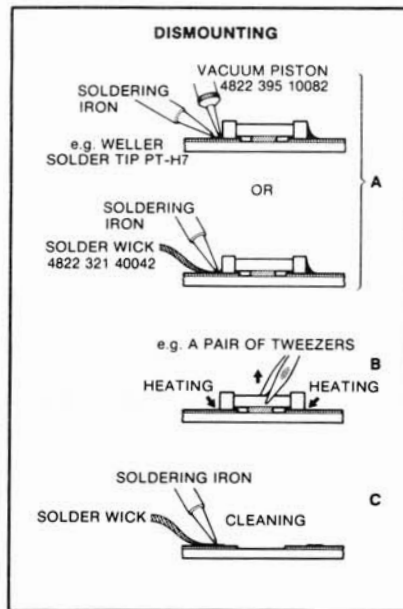
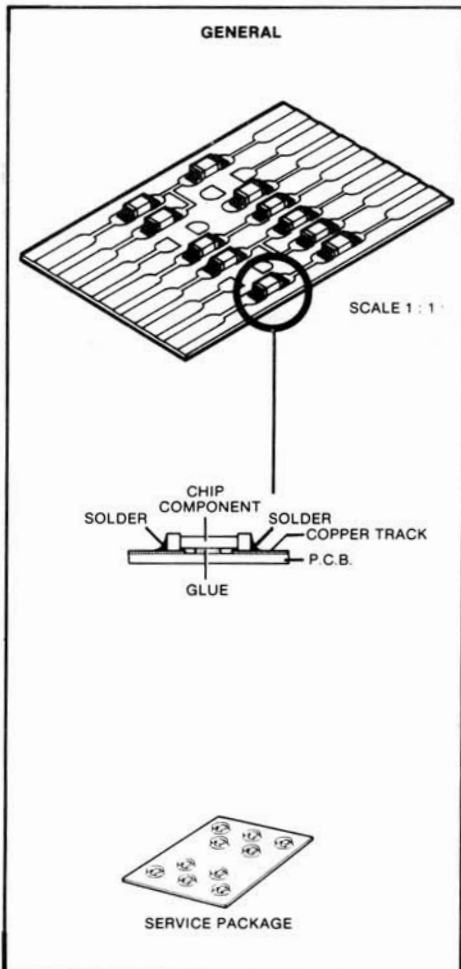
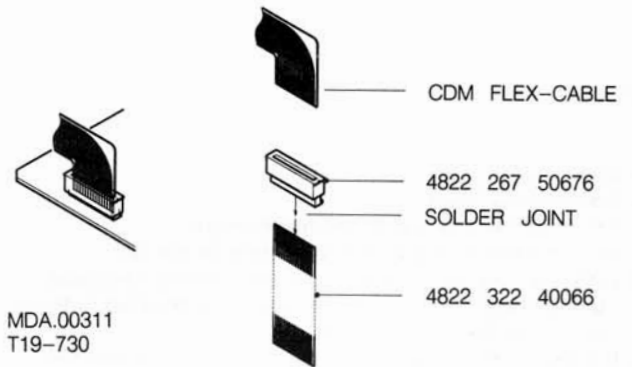

Fig. 1

DISASSEMBLY OF TOP COVER

- Remove the 4 screws out of side walls of top cover.
- Take top cover from set.

SERVICING OF THE FRONT PANEL

Disassembly of front panel

- Remove top cover.
- Remove the 3 fixing screws at upper side of front panel.
- Now the front panel can be taken off.
- Ensure during mounting that the 3 bosses of the set frame engage with the appropriate holes of the frontpanel.

Disassembly of control + display panel

- The control and display PCB can be detached by removing the 4 screws 3Mx16 at the bottom of the display panel.
- Then the control + display panel can be taken out of the front.
- When mounting, make sure that the 2 bosses on the PCB slip into the appropriate holes in the front.

SERVICING OF THE TRAY MECHANISM

- Demounting the tray mechanism.
- Remove the top cover.
- Remove the front.
- Remove the tray out of the mechanism.
- Remove the screw from the bottom of the set.
- Undo the 3 screws with which the loading has been mounted into the set. Two screws are situated in front and one in the centre at the rear.
- Lift the tray mechanism a little and undo the flexible PCB from the connector by lifting the upper part of the connector and taking the flexible PCB out. Short circuit the connections by means of a paperclip.
- Undo the 2 stocko connectors.
- Now take the tray mechanism out of the set.

DEMOUNTING THE CDM

- Remove the complete disk hold-down.
- Turn the loading upside down.
- Support the CDM.
- Loosen the 2 screws on the metal bracket with which the CDM is suspended.
- The CDM can now be removed.
- For servicing the CDM see Service Manual CDM2/0500.
- Mounting is done in reverse order.

SERVICING THE SERVO + DECODER PANEL

- Remove top cover.
- Remove the front panel.
- Remove the tray mechanism.
- Remove the screw with which the chassis part is fixed.
- Remove the screw in the rear with which the CINCH sockets are fixed.
- Remove the screws on the PCB.
- Remove the screws from the transformer.
- The PCB now can be taken out.
- Mounting is done in reverse order.

REPLACEMENT OF TRANSFORMER FUSE

- For replacing the transformer fuse the transformer must be desoldered from the main panel.

4. ELECTRICAL MEASUREMENTS AND ADJUSTMENTS

HINTS

Test disc

It is important to treat the test discs with great care. The disorders on the discs (black spots, fingerprints, etc.) are exclusive and unambiguously positioned. Damage may cause additional drop-outs, etc. rendering the intentional errors no longer exclusive. In that case it will no longer be possible to check e.g. the good working of the track detectors.

Measurements on op-amps

In the electronic circuit op-amps have been used frequently. Some of the applications are amplifiers, filters, inverters and buffers.

In those cases where in one way or the other, feedback has been applied the voltage difference at the differential inputs converges to zero. This applies to both DC and AC signals. The cause can be traced to the properties of an ideal op-amp ($Z_i = \infty$, $G = \infty$, $Z_o = 0$). If one input of an op-amp is directly connected to ground it will be virtually impossible to measure at the inverting and the non-inverting inputs. In such cases only the output signal will be measurable.

That is why in most cases the AC voltages at the inputs will not be given. The DC voltages at the inputs are equal.

Simulation with "0" and "1"

During troubleshooting sometimes certain points should be connected to ground or supply voltage. As a result certain circuit can be brought in a desired state thus shortening the diagnosis time. In a number of cases the related points are outputs of op-amps. These outputs are short-circuit-resistant, i.e. they can be brought to "0" or ground without problems.

The output of an op-amp, however, should never be connected directly to the power supply voltage.

Measurements on microprocessors

Inputs and outputs of microprocessors should **never** be connected directly to the power supply voltage. The inputs and outputs should only be brought to "0" or ground if this is stated explicitly.

Measurements with an oscilloscope

During measurements with an oscilloscope it is recommended to measure with a 1:10 test probe, since a 1:10 probe has a considerably smaller input capacitance than a 1:1 probe.

Selection of ground potential

It is very important to select a ground point that is as close as possible to the test point.

Conditions for injection

- Injection of levels or signals from an **external** source should **never** take place if the related circuit has no supply voltage.
The injected levels or signals should never be greater than the supply voltage of the related circuit.

GENERAL CHECKPOINTS

In the detailed measuring method below a number of general conditions, required for a properly functioning set, will not be mentioned. Before the detailed measuring method is started, these general points should first be checked.

- Ensure that disc and objective are clean (remove dust, fingerprints, etc.) and work with undamaged discs.
- Check if all supply voltages are present and if they have the correct values.
- Check the good working of the CD mechanism by means of the servicing programme.

Indication of test points

In the drawings of the diagrams and the panels, the test points have been indicated by a number (e.g. 12) to which the measuring method refers. In the measuring method below, the symbol (◇) has been omitted for the testpoints indicated.

Initialization of the service program of the μ P

- Servicing position "0"

Press the STOP/CM, NEXT and PAUSE keys. Keep these three keys depressed while switching on the mains voltage. This is the 1st standby position. The number of the internal ROM program of the μ P (e.g. P101) appears on the display. The "TRACK" Led lights up as well. In this position the radial arm of the CDM can be driven inwards (with SEARCH \gg) and outwards (with \ll SEARCH) with minimum torque. When one of these search keys is actuated, laser control and focus control become active as well. If a disc is put on the turntable, the working of the focus control can already be observed in this position. (If the arm moves outwards and inwards, you can hear the optical pick-up unit jump across the tracks).

Attention: After one of these keys (SEARCH \gg , \ll SEARCH) is pressed, the laser remains controlled up to service position 3.

Avoid, therefore, direct exposure to the laser beam in service positions 0, 1 and 2).

- Servicing position "1"

From service position "0" the player can be brought into service position "1" by pressing the "NEXT" key. The indication "0001" appears on the display. In this position the focus start procedure is repeated over and over again. The laser control is active. However, this start procedure does not release the focus control. So we cannot ascertain that the focal point is found. This position is very suitable, however, for measurements of the focus circuit. In service positions 1 and 2 the arm with the rafoc unit can be moved inwards and outwards with the SEARCH \ll key and the \gg SEARCH key respectively. In this way the free movement of the arm under the disc can be checked.

sturen. Daarmee kan de vrije beweging van de arm onder de plaat worden gecontroleerd.

- Service position "2"

To be attained by pressing the "NEXT" key after service position "1" is reached. The indication "0002" appears on the display. Make sure that the rafoc unit is within the reach of the disc. If a disc is put on the turntable in this position, the working of the decoder (MC signal) and the turntable motor control can be checked (turntable motor is running at the right speed). Laser control, focus control and turntable motor control are active. This position is very suitable for measurements of the turntable motor control. If the HF signal is not well coded or if no disc is present, the turntable motor will start rotating at maximum speed.

- Service position "3"

To be attained by pressing the "NEXT" key after service position "2" is reached. The indication "0003" appears briefly on the display. Then the normal standby display is shown. The set is now in the 2nd standby position. All keys have their original function again. In case of deviations an extensive error indication takes place via the display.

- If the μ P observes a system error, a system error indication will appear on the display: Er 01 to Er 08.
 - If the μ P observes an operating error, an operating error indication will appear on the display for 1.5 sec.: Er 30 to Er 37 and Er 60 to Er 61.
- For an explanation of the error indications: See Error table.

The service program can be abandoned by turning the mains switch (POWER ON/OFF) off and on again (Hardware reset).

ERROR TABLE

Er 01: RD pulse is missing. Check the start capacity Sc, the RD signal and the photodiode signal processor. (Starting error)

Er 02: TL pulse is missing during start-up. Check the TL signal, the HF-signal and the Photodiode signal processor. (Starting error)

Er 03: Lead-in track not found. Check the disc used. Check also that the radial arm rests against the inside. Check the RE-dig signal and the Radial error processor. (Starting error)

Er 04: Too many TL pulses during play. Check the quality of the disc used. Check the HFD signal. (Error during PLAY)

Er 05: TL pulse is low for more than 50 msec. Check the disc used. Check the HF-in signal and the photodiodes (Error during PLAY).

Er 06: No TL pulse received within 0.5 sec. during track jumping. Check the RE-lag circuit. (Error during SEARCH or NEXT/PREVIOUS)

Er 07: Subcode error. In case of track loss during play the information of the subcode is used to determine the place of the last information that was still well readable. In case of an interruption of HF or other signals, this will lead to Er 07. (Error during PLAY)

Er 08: TOC error (Table of Contents). Check the quality of the disc used. Check the initial speed of the turntable motor and the motor control. Check also that the radial arm rests against the inside. (Starting error)

Temporary errors

- Er 30: NEXT when repeat is off.
 Er 31: PREVIOUS when repeat is off.
 Er 32: INDEX selected when no track selected.
 Er 33: Selected index does not exist on this CD.
 Er 34: Review error: no program.
 Er 35: Program memory full.
 Er 36: Programmed track is non existing on this CD.
 Er 37: Selected track is non existing on this CD.
 Er 60: Fast forward bound.
 Er 61: Fast reverse bound.

Specification measurement

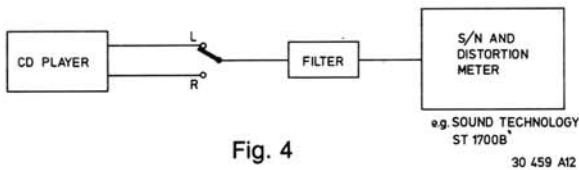

Fig. 4

To measure the specification use can be made of audio test disc 4822 397 30095.

Use 13th order filter 4822 395 30204 to measure (see Fig.4):

- Total harmonic distortion (THD)
- Intermodulation distortion
- Signal-to-noise ratio (S/N)

Continuous burning of the laser see:

Initiation of the servicing programme, service position "0".

Note: Danger

Invisible laser radiation.
 Avoid direct exposure to beam.

Check of the laser supply

The laser and, the laser supply in IC6525 plus the monitor diode form a feedback system.
 A defect in the laser supply can result in the destruction of the laser.

If, in that case, the laser (= complete CDM2 unit) is replaced, the new laser will also become defective. However, it is impossible to check and repair a feedback system if a link is missing. The laser supply can be checked with the circuit below. The green LED replaces the laser, the voltage across the 18 Ohm resistor is feed back as monitor voltage, the 33 Ohm resistor and the switch serve to draw more current from the laser supply.

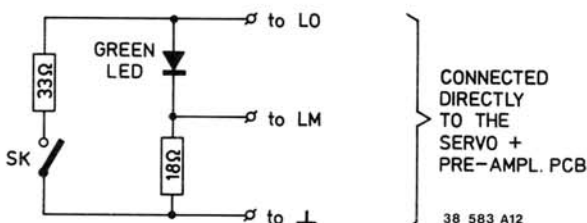

LED GREEN e.g. CQY 94 IV

5322 130 32182

The above circuit is connected to the connector on the main panel via an extension cable instead of a flex print. The normal flex print is not suited for this purpose because of its high internal resistance.

Code no. extension cable 4822 322 40066

- Take the above flex print out of the connector on the main panel.
- Connect the circuit via the extension cable to the connector.
- Select the play mode by grounding \bar{S}_i (pin 20 of IC6525).
Note: $\bar{S}_i = 0$, start initialisation low, is the play mode.
- Measure the voltage LO (Laser Out) at test point 9.

SK open: $1,8 \text{ V} \leq \text{LO} \leq 2,3 \text{ V}$
 $170 \text{ mV} \leq \text{LM} \leq 220 \text{ mV}$
 The green LED emits little light.

SK closed: $1,8 \text{ V} \leq \text{LO} \leq 2,3 \text{ V}$
 $170 \text{ mV} \leq \text{LM} \leq 220 \text{ mV}$
 The green LED emits little light.

- During the change over from SK closed to SK open, the LED will emit more light for a short moment.
- The control sees to it that the same amount of current flows through the LED when SK is open and when SK is closed.

At $\bar{S}_i = 1$, in the STAND-BY state, $\text{LO} = 0 \text{ V} \pm 0,2 \text{ V}$.

Repair procedure

Since laser, monitor diode and photodiodes are very sensitive to static charges, care should be taken that during measurements and adjustments the aids and yourself have a potential that is equal to that of the CD mechanism.

Attention: When exchanging the CDM2 unit, the laser output potentiometer 3528 should be placed in mechanical mid-position to avoid damage to the laser.

Adjusting the laser current.

Coarse adjustment

- Place potentiometer 3528 approximately in mid-position.
- Put test disc 5 on the turntable.
- Bring the player in service position 3, position Play.
- The focusing motor can now start focusing and when it has found the focal point index "01" will appear on the display.
- If this does not happen, turn potentiometer 3528 clockwise or anti-clockwise a little and press the playbutton again.
 Here after the fine adjustment of the laser current has to be carried out.

Fine adjustment

- Play track 1 of the test disc 5.
- Adjust potentiometer for a voltage across 3508 test point 1 and 2 of $50 \text{ mV} \pm 5 \text{ mV}$.

Adjustment of the focus off-set

Coarse adjustment

Adjust the focussing motor to the eye for a horizontal position by means of potentiometer 3517.
 - Here after the fine adjustment of the focus off-set has to be carried out.

Fine adjustment

- Bring the player in service position 2.
- Adjust potentiometer 3517 for a voltage across 2545 (test point 27) of $400 \text{ mV} \pm 40 \text{ mV}$.

Note: Notice that the CDM is in a horizontal position.

Changing the transformer connections

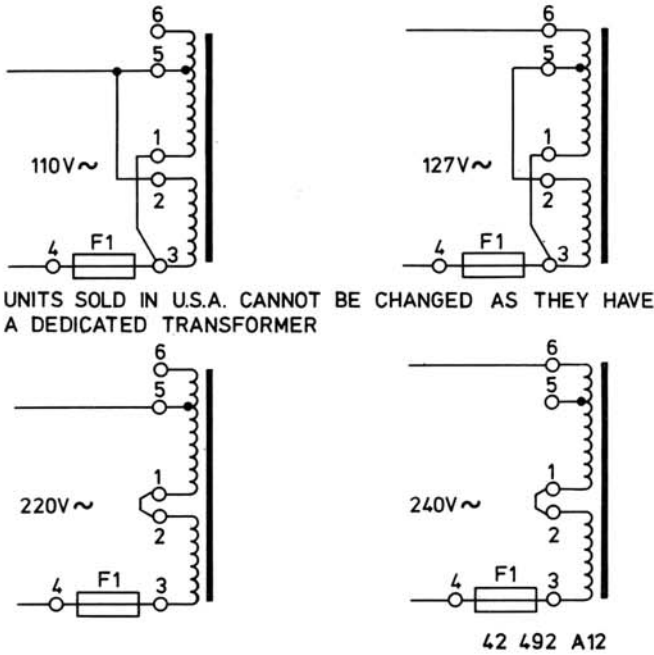

Fig. 6

If the set should be connected to a mains voltage that deviates from the voltage mentioned on the type plate, the transformer connections should be changed, as indicated in Fig. 6.

DETAILED MEASURING METHOD

I. μ P IC6551

● **Servicing program**

For initiation of the servicing program see: General checkpoint: Initiation of the service program.

● **Reset (pin 1, testpoint 14)**

When the supply voltage is switched on, a positive pulse should be present.

● **X-tal out (pin 39; test point 13)**

The frequency of this signal should be 6 MHz.

● **MSTP (pin 26; test point 78)**

When, after RD "high", the $\overline{\text{MSTP}}$ is "high" for a short moment (> 0.2 sec.), the turntable motor control will be switched on.

The turntable motor is controlled by the MC-signal (test point 12).

To check MC, see: "Decoder A IC". To check the turntable motor control see CDM2 Service Manual "Checking of the motor control".

● **B0 (pin 11; test point 36)**

B1 (pin 10; test point 34)

B2 (pin 9 ; test point 33)

B3 (pin 8 ; test point 32)

With the B0 + B3 signals

- The radial control is switched on.
- The level on the DAC output is controlled.
- In the SEARCH mode, there should be activity on all 4 test points.
- In the following positions the signals B0 + B3 are stable:

signal	STOP	PLAY	Service pos. 0,1,2	Service pos. 3 pos. Play
B0	"low"	"high"	"low"	"high"
B1	"high"	"high"	"high"	"high"
B2	"high"	"high"	"high"	"high"
B3	"low"	"low"	"low"	"low"

● **$\overline{\text{TL}}$ (pin 34; test point 16)**

- The $\overline{\text{TL}}$ signal (Track Lost) is used to tell the μ P that track loss threatens. The μ P then can give correction signals with B0 + B3.
- In the "SEARCH" mode, or when the player is bumped against, there are pulses on test point 16.

● **REdig (pin 7; test point 37)**

The REdig signal (= Radial Error Digital = radial deviation) is used to determine the place of the arm relative to the track and to check/correct in case of track jumping or bumping against the player.

In servicing position 3 position Play or in the PLAY mode, a square wave should be present on test point 37.

Because of frequency variations, this square wave is hard to trigger.

● **$\overline{\text{DODS}}$ (pin 5; test point 19)**

The $\overline{\text{DODS}}$ signal (= Drop Out Detector Suppression) avoids that Drop-Out signals influence the arm control during track jumping.

POSITION PLAYER	POWER ON	SERVICE POSITION 3	PLAY	SEARCH, PAUSE
$\overline{\text{DODS}}$ SIGNAL	"LOW"	"HIGH"	"HIGH"	

MDA.00364
T12 -638

II. PHOTODIODE SIGNAL PROCESSOR IC6525

- **SC (pin 25, testpoint 20)**
SC (= Start Capacitor)

High Ohmic measurement

Position of player	SC (pin 25)
POWER ON	-4 V
PLAY	+5 V
Servicing pos. 1	+5 V

- **Si (pin 20; test point 21)**
LO (pin 17; test point 9, 9^A, 9^B)

- With the Si signal (= Start Initialization) the laser supply, among other things, is switched on. When the Si signal is "low", the LO signal (= Laser Out) should be "high".
Via the LM signal (= Laser Monitor) the power supply for the laser diode is controlled.

Position of player	POWER ON	Servicing pos. 1*)	PLAY
Si signal	"high"	"low"	"low"
LO signal	"low"	"high"	"high"

- **LM (pin 16; test point 11) to check LM**
See general checkpoints 'check of the laser supply'
- **To check the laser supply**, see General checkpoints "Check of the Laser Supply".
- **To check the focus offset**, see General checkpoints "Adjustment of the Focus Offset".

*) To ensure that the player stays in servicing position 1, there should be a disc on the turntable.

- **FE pin (pin 5; test point 26)**

- The FE signal (= Focus Error) is used to drive the focusing unit. When the Si signal goes to "high", the focal point will be searched for.
- When the player is brought into servicing position 1, the objective will keep repeating the focus start procedure. At test point 26 the FE signal varies between +1,5 V and -1,3 V.

- **RD signal (pin 21; test point 24)**
HIGH-OHMIC MEASUREMENT

The RD signal (= Ready) will go high when the starting procedure of IC6525 has been completed.

- **RD (pin 21; testpoint 24)**

Het RD-signaal wordt "hoog" wanneer de opstart procedure van IC6525 voltooid is.

(Hoogohmig meten)

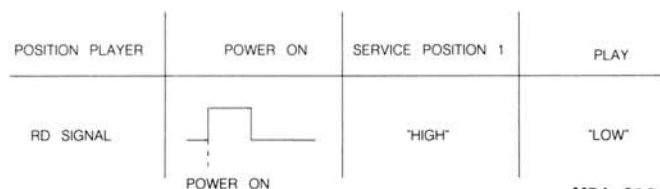

MDA 636

- **D1 (pin 9 ; test point 4)**
D2 (pin 10; test point 6)
D3 (pin 8 ; test point 7)
D4 (pin 7 ; test point 8)

- The signals D1+D4 are the error signals from the photodetector circuits.
- When in servicing position 2 the disc is moved, the focusing unit should keep in track. When the disc is moving, there should be a changing signal on test points 4, 6, 7 and 8.

Check of the photodetector.
Connected the circuit below to an alternating voltage of 17,5 V.

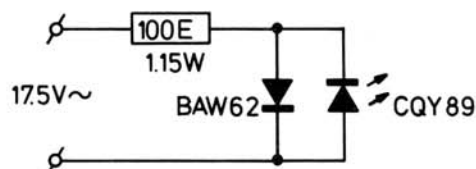

39 368 A12

- 100 E-1.5 W - 4822 116 51098
- BAW 62 - 4822 130 30613
- CQY 89 - 4822 130 31332

Switch on the supply voltage and bring the player in the stand-by mode or in servicing position 0. In this measurement, infrared diode CQY89 replaces the function of the laser diode. When this diode is held above the objective unit, the infrared light falls on the 4 photodiodes. When the 4 photodiodes are functioning, the following voltage form will be visible on test point 4, 6, 7 and 8. (The amplitude depends on the distance between the IR diode and the objective).

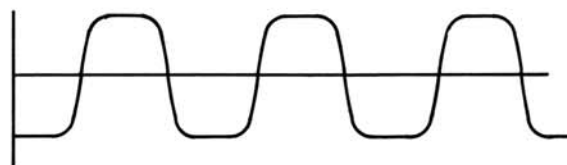

38 314 A12

Position of the oscilloscope: 100 ms/div.

- **HF-in (pin 3, test point 3)**

- The HF-signal (= High Frequency in) is the information signal from the 4 photodiodes.

- **HF-out (pin 27; test point 17)**

- The HF-out signal (= High Frequency) is the amplified information signal for the decoder circuit. During playback of test disc no. 5 (4822 897 30096), a so-called "eye pattern" should be present on test point 17 (see figure below).
- The HF signal should be present and stable in the PLAY mode.

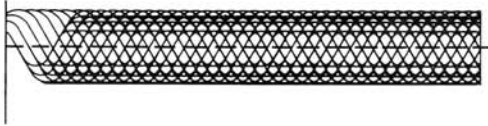

Position of the oscilloscope: 0,5 μ s/div.
Amplitude about 1,5 V_{pp}

- **DET (pin 26)**
HFD (pin 19; test point 23)
TL (pin 18; test point 16)

- The DET signal (= Detector) gives information on the level of the HF signal to the high-frequency. Level-Drop-out detector IC6525.
- When the level of the HF signal is too low, the HFD signal (= High Frequency Detector) will go "low".
- The TL signal (= Track Lost) will then go "low" in order to tell the μ P that the tracking signals Re_1 and Re_2 are unreliable.

Method:

(Can only be used in a playing set).

- Put test disc 5A 84822 397 30096) on the turntable.
 - Switch on the power-supply switch and press the PLAY key.
 - Play track number 10 or 15 and check the HFD signal at test point 23.
- When drop-out pulses are present on the DET signal (pin 26), the HFD pulses should also be present at test point 23.
(Position of oscilloscope: 2 ms/div.).

When the disc is slowly braked by hand, TL pulses will be visible at test point 16.

- **RE1 (pin 11; test point 18)**
RE2 (pin 12; test point 22)

- Signals RE1 and RE2 (Radial Error) are the control signals for the arm during tracking.
- In servicing position 3, position Play the following signals should be visible at test point 18 and 22.

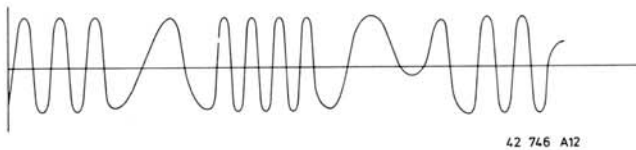

Position of the oscilloscope: 2 ms/div.
The frequency strongly depends on the eccentricity of the disc.

III. RADIAL ERROR PROCESSOR IC6529

- **Check the signals between the μ P and the Radial Error and the signals between the photo diode signal processor and the Radial Error Processor.**

- **DAC (pin 10; test point 38)**

With the DAC signal (= Digital B0+B3 signal converted into the Analogue signal) the track jumping speed is controlled.
This signal is derived from the signals B0 + B3 coming from the μ P.

- **RE-lag (pin 8; test point 41)**

Capacitor 2559 in the RE-lag circuit has a memory function.
It memorizes the degree of inclination of the disc. When a jump is made to a certain track on the disc, the memory should be cleared.
This is done by the μ P (RPU signal) via transistors 6533, 6534.

During track jumping (SEARCH), slow pulses should be visible at test point 43 (position of the oscilloscope 0,1 ms/div.)
In that case pulses should also be visible on the collector of transistor 6533, 6534.

IV. DECODER-A IC

- **Check the MC signal (pin 17; test point 12)**

- In stand-by mode, the MC signal (Motor Control) corresponds to the figure below.
- Place a disc on the turntable.
- In position PLAY or SERVICE POSITION 3 position Play the MC signal corresponds to the figure below.

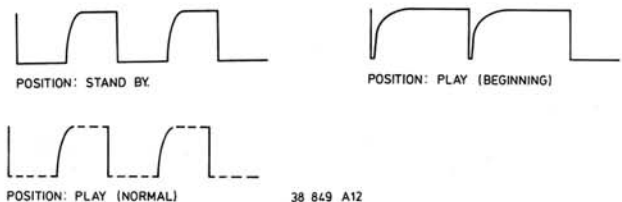

- **Check the HFD-signal on test point 66, pin 26**

- Insert a disc.
- In the PLAY mode and in SERVICING POSITION 3 position Play the HFD-signal is "high"; however, minor pulses may be present and in case of disorders on the disc.
- During playback of track no. 15 of test disc 5A HFD pulses are visible.

Position of the oscilloscope 5 ms/div.

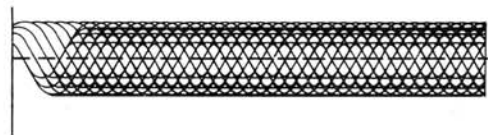

Note:

During start-up the duty cycle is 98%, then the duty cycle of the signal becomes about 50%.

- **VC (connector point 15-1; test point 46)**

- Place a disc on the turntable.
- The voltage at connector point 15-1 during playback will be:
 $V_C = 0 > V_C > -1.7 V$
To check the turntable motor control, see C.D.M.-2 Service Manual: "Checking of the motor control".

- **Check the HFI signal test point 65 pin 25 (eye pattern)**

- Place a disc on the turntable.
- The HF signal is present and stable in the position Play. See figure below.



● Check the CEFM signal (pin 27; test point 68)

- Place a disc on the turntable.
- In stand-by mode (only the mains switch is depressed), the frequency lies between 2.82 MHz and 5.64 MHz.
- In the position PLAY the frequency is 4.32 MHz.

● Check the Xin signal (pin 19; test point 69)

- The Xin frequency is 11.2896 MHz.
- If this frequency deviates, check test point 70; Xout signal, on Filter-B IC. This frequency should also be 11.2896 MHz.

● Check the timing signals meant for Filter-B IC

- Place a disc on the turntable.
- Select one of the following positions: SERVICE POSITION 3 position Play or position PLAY.
- Trigger the oscilloscope with the WSAB signal (test point 71; pin 39).
- Check signals:
 - WSAB at test point 71 (pin 39)
(Word Select from Decoder-A to Filter-B)
 - CLAB at test point 72 (pin 38)
(Clock from Decoder-A to Filter-B)
 and their interrelation.
- There must be activity a test point 73 (pin 37), DAAB signal (DATA from Decoder-A to Filter-B).

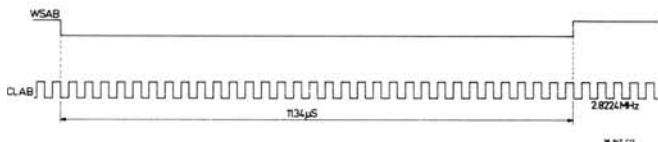

● Check the EFAB signal (Error Flag from Decoder-A to Filter-B) at test point 74 (pin 36)

- Place test disc 5A on the turntable.
- Select one of the following positions: SERVICE POSITION 3 or position PLAY.
- During playback of track no. 17, a EFAB pulse should appear at test point 61 for a short moment. The EFAB pulses also appear when the disc is gently slowed down and during fast search (Fast Forward or Fast Reverse).

Note:

Filter-B IC is capable of interpolating linearly 8 successive EFAB pulses.

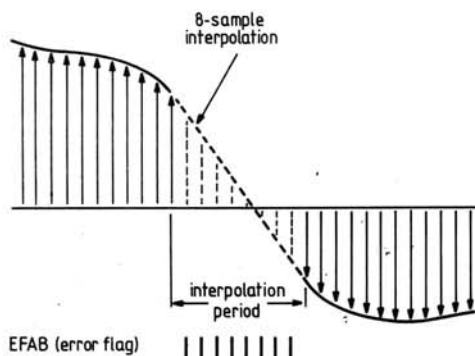

38 845 A12

● Check the Q-channel signals

- Place a disc on the turntable.
- Select one of the following positions: SERVICE POSITION 3 position Play or position PLAY.
- Trigger on the QRA signal (Q-channel Request Acknowledge) test point 75; pin30.
- Check signals: QRA at test point 75 (pin 30)
QCL a test point 76 (pin 31)
(Q-channel-clock)
and their interrelation.
- There should then be activity at test point 77 (pin 29) QDA (Q-channel Data).

Note:

The QRA request is initiated by the μP (QRA "high"). Then Decoder-A answers this request (QRA goes "low"). With the next leading clock pulse (QCL) the QRA signal is rendered "high" again by the μP . As soon as the μP has taken in enough information via QDA, QRA will go low again. That is why the QRA times vary each time.

Daarom zullen de QRA tijden telkens variëren.

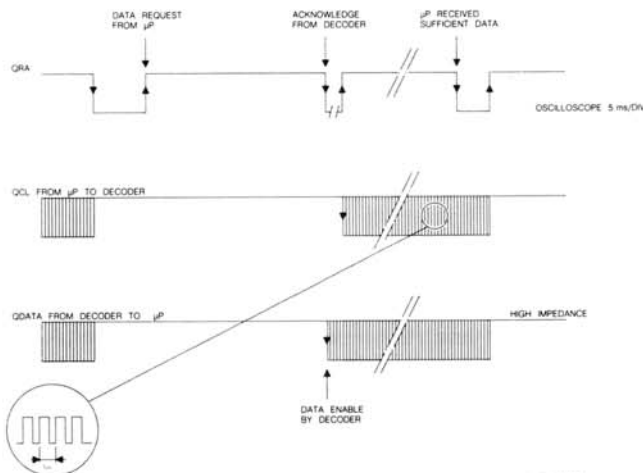

● Check the \overline{SSM} signal (test point 78; pin 33) = Start-Stop turntable motor

- Motor start pulse when test point 78 is "high" for ≥ 0.2 sec.
- Motor stop pulse when test point 78 is "low" for ≥ 0.2 sec.

Note:

After the motor start pulse, SWAB information (Subcoding Word clock) will become visible at this point. The period time of that signal is 136 μ sec.

● Check the subcode clock signals

- Place a disc on the turntable.
- Select one of the following positions: SERVICE POSITION 3 position Play or position PLAY.
- Trigger the oscilloscope with the SWAB signal at test point 78.

- Check the following signals:
SWAB at test point 78; pin 33
SCAB at test point 79; pin 35 (Subcode Clock from Decoder-A to Filter-B)
SDAB at test point 80; pin 34 (Subcode Data from Decoder-A to Filter-B)
and their interrelations.

Note:

While the burst of 10 clock pulses appear on SCAB the Q-channel information is transferred on SDAB. Hereafter the P-bit indication follows. The P-bit is "high" between two bursts of 10 clock pulses in case of pause indication and "low" in case of music indication.

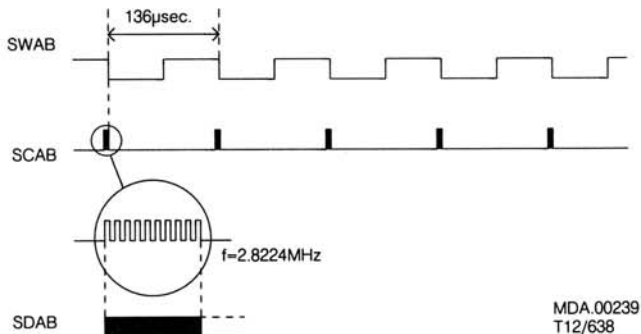

- **Check the $\overline{\text{CRI}}$ signal (pin 28)**

The $\overline{\text{CRI}}$ signal is "low" in case of track jumping. Player in position SEARCH.

- **Check the DEEM signal (test point 84; pin 32)**

- Place test disc 5 on the turntable.
- During playback of track no. 14 (recorded without PRE-EMPHASIS), the DEEM signal should be "low".
- During playback of track no. 15 (recorded without PRE-EMPHASIS), the DEEM signal should be "high".

V. FILTER-B IC

- **Check the signals between Decoder-A IC and Filter-B IC**

- See sub. "IV. Decoder-A IC":
* Check the X-tal signal
* Check the timing signals meant for Filter B (WSAB, CLAB, DAAB signals; test points 71, 72 and 73).
* Check the EFAB signal (test point 74)
* Check the subcode clock signals (SWAB, SCAB, SDAB signals; test points 78, 79 and 80).

- **Check the timing signals between Filter-B IC and DAC IC**

- Place a disc on the turntable.
- Select one of the following positions:
SERVICE POSITION 3 position Play or position PLAY.
- Trigger the oscilloscope with the WSBD signal (Word Select from Filter B to DAC) test point 85 (pin 18).

- **Check the following signals:**

WSBD at test point 85; pin 18
CLBD at test point 87; pin 16 (Clock signal from Filter B to DAC)
and their interrelation.

If an Audio Disc is used, there should be activity at test point 86 (pin 15) DABD signal (DATA from Filter B to DAC).

If a disc with Digital Data (CD-ROM) is used, this point is continuously switched "low" by transistor 6562.

- **Check the DOBM signal (Digital Output)**

- Place a disc on the turntable.
- Select the stand-by mode (only mains switch depressed).
- Trigger the oscilloscope with the WSAB signal (test point 71).
- Check the DOBM signal (test point 88; pin 14)
- An empty audio signal has a fixed pattern. See drawing "Stand-by".
- Select the PLAY mode.
Check the DOBM signal. See drawing "PLAY".

- **In position SEARCH the $\overline{\text{ATSB}}$ signal is "low" (test point 89; pin 22) (Attenuation Audio Signal)**

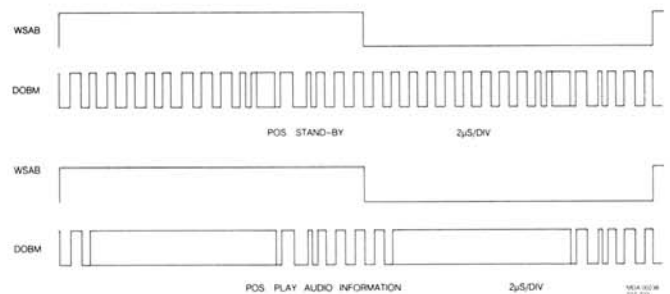

- **Check the $\overline{\text{MUSB}}$ signal test point 90; pin 23 ((Soft Mute)**

This signal is "low" in positions:

PAUSE

NEXT or PREVIOUS when jumping from one track to another.

Fast SEARCH when the search button is kept depressed for some time.

VI. DAC IC (Dual Digital Analog Converter)

- **Check the signals between Filter-B IC and DAC IC**

- See sub. "V. Filter-B IC":
* Check the timing signals between Filter-B IC and DAC IC

- **Check the output of the OP-AMP after the DAC IC**

- Place a disc on the turntable.
- In position PLAY or in SERVICE POSITION 3 position Play, the analog (music) signal should be present at the output of the OP-AMP, after the lead-in track has been read.

VII. DEEM CIRCUIT

● Check DEEM circuit

- Place test disc 5 on the turntable.
- During playback of track no. 14 (recorded without PRE-EMPHASIS) the DEEM signal at test point 84 should be "low".
- During playback of track no. 15 (recorded with PRE-EMPHASIS) the DEEM signal at test point 84 should be "high".
- During playback of track no. 14 the analogue signal should be present at the source of 6583 (test point 91) and 6582 (test point 92).
- During playback of track no. 15 the analog signal at the source of 6583 (test point 91) and 6582 (test point 92) should be 0 V.

VIII. KILL CIRCUIT

- During switching on and off the mains voltage the signal on the collector of 6580 (to be measured on a jumper, tp93) should be as indicated in the figure below.

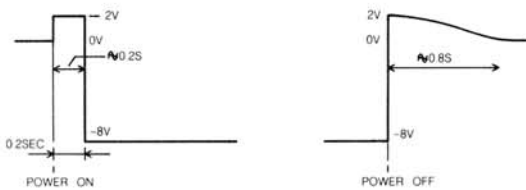

MDA 00134
T07/733

EXPLODED VIEW LOADING**Partslist
loading**

101	4822 466 92111
102	4822 325 60317
103	4822 444 50582
104	4822 358 10115
106	4822 522 32359
107	4822 532 51756
108	4822 402 61081
109	4822 528 90638
111	4822 402 61107
112	4822 492 63659
113	4822 444 60467
114	4822 492 32762
116	4822 528 90639
117	4822 532 11547
118	4822 462 50383
119	4822 492 51902
121	4822 466 61587
122	4822 492 63746
123	4822 361 20998
124	4822 402 50244
126	4822 492 51935

**Partslist
cabinet**

201	4822 444 40208
202	4822 459 10771
203	4822 492 51944
204	4822 410 26055
206	4822 450 61109
207	4822 444 60507
208	4822 444 50589
209	4822 492 32762
211	4822 402 50245
212	4822 410 26056
213	4822 462 40409

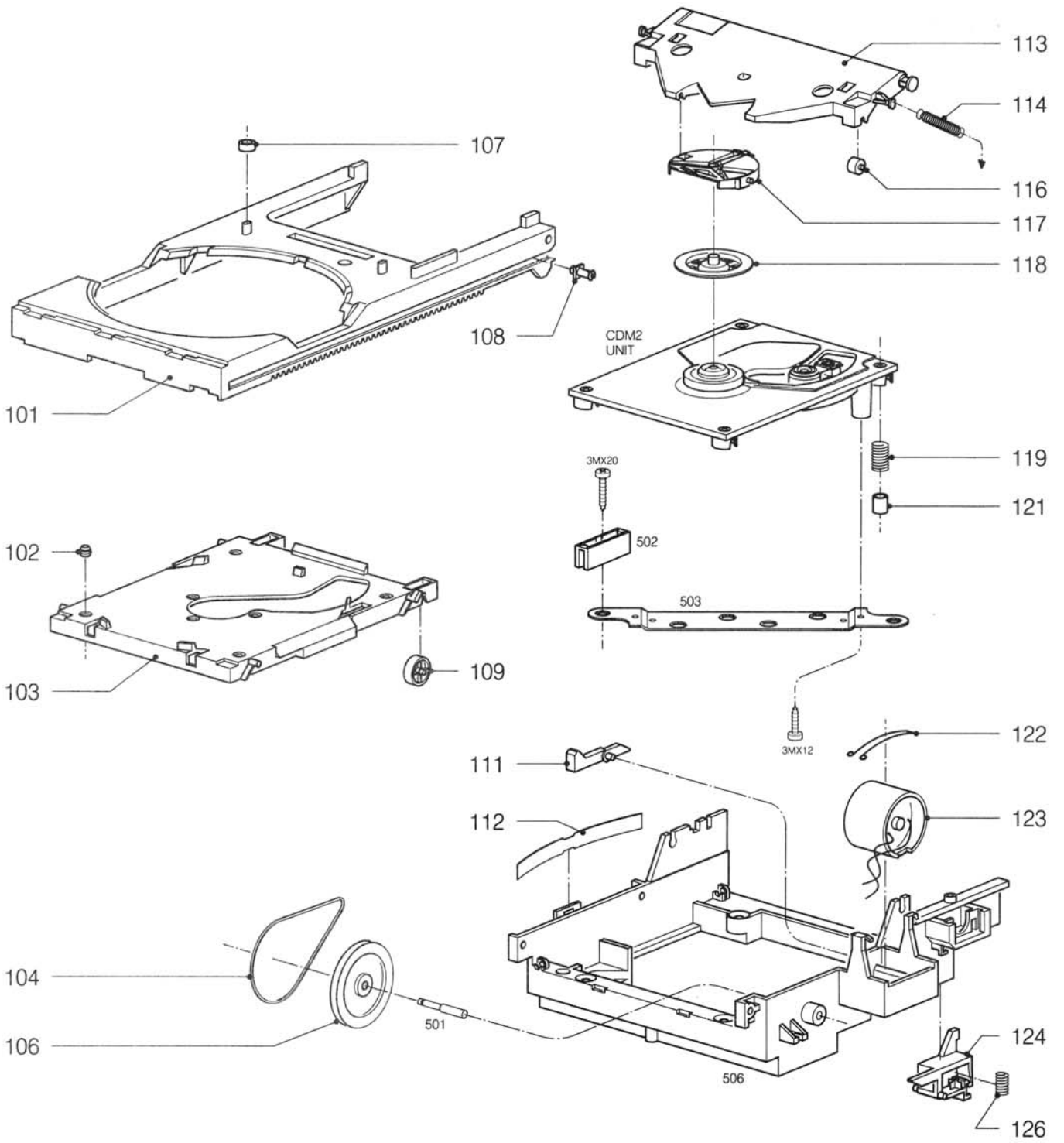

EVA.00365
T07/722

1001	J 1	2527	F 3	2532	F 6	2537	J 12	2543	K 13	2548	J 3	2557	F 21	2563	I 15	2569	N 15	2585	A 10	3512	E 8	3517	L 12	3522	K 13	3527	L 11	3533	J 3	3139	D 18	3544	G 20	3550	F 19	3555	D 19	3561	M 6	3581	A 7	3806	H 11	6526	J 12	6532	F 20	6539	M 5
1002	J 1	2528	E 5	2533	F 8	2538	J 13	2544	J 11	2549	K 13	2558	E 18	2564	I 15	2571	M 4	3508	F 3	3513	E 9	3518	L 11	3523	K 12	3528	L 3	3534	G 10	3140	I 13	3545	G 20	3551	G 19	3557	L 17	3562	L 14	3582	A 9	3807	G 11	6527	J 3	6533	J 18	6551	B 5
1003	J 1	2529	E 4	2534	F 9	2539	E 7	2545	L 9	2551	H 11	2559	G 18	2566	L 17	2581	A 8	3509	F 3	3514	E 6	3519	L 13	3524	K 11	3529	K 3	3536	D 8	3141	C 15	3546	F 20	3552	J 18	3558	L 17	3563	N 17	3583	A 10	6334	I 17	6529	D 12	6536	M 18		
1502	A 10	2530	E 5	2535	F 10	2540	L 13	2546	J 4	2555	C 17	2561	I 14	2567	L 17	2582	A 8	3510	E 7	3515	J 12	3520	L 13	3525	J 11	3530	J 3	3537	J 17	3142	D 15	3548	E 19	3553	J 18	3559	M 16	3564	M 4	3599	A 11	6525	I 5	6530	C 14	6537	M 18		
2526	F 3	2531	E 5	2536	H 10	2542	K 12	2547	I 10	2556	C 14	2562	I 14	2568	M 16	2584	A 10	3511	D 6	3516	F 6	3521	J 13	3526	K 10	3532	I 3	3538	D 11	3143	F 21	3549	F 18	3554	I 17	3560	M 16	3565	M 4	3803	H 3	6526	E 20	6531	F 20	6539	M 17		

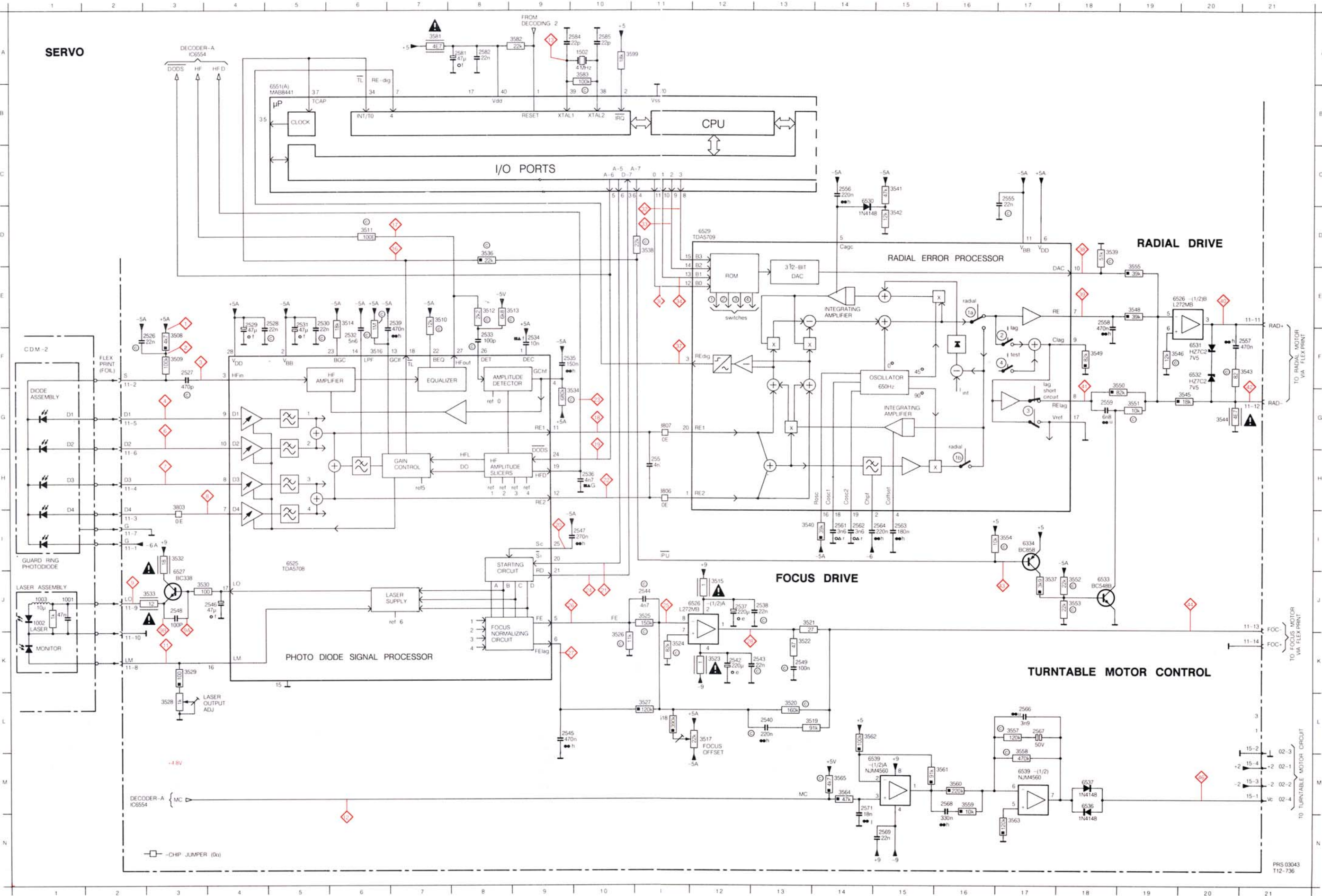

2501 F 8	2509 D 4	2512 E 6	2515 E 4	2518 F 5	3503 D 2	3808 B 1	6503 B 5	6506 C 3	6509 D 5	6512 D 3	6515 F 4	F1 G 9
2507 C 4	2510 D 3	2513 D 4	2516 E 3	2519 F 3	3504 E 2	5001 E 8	6504 B 5	6507 C 2	6510 E 5	6513 E 2	6517 B 3	SK1 G 8
2508 C 3	2511 D 6	2514 E 4	2517 E 3	3502 G 4	3505 F 2	6502 B 5	6505 C 5	6508 D 5	6511 E 5	6514 E 2	6522 G 4	

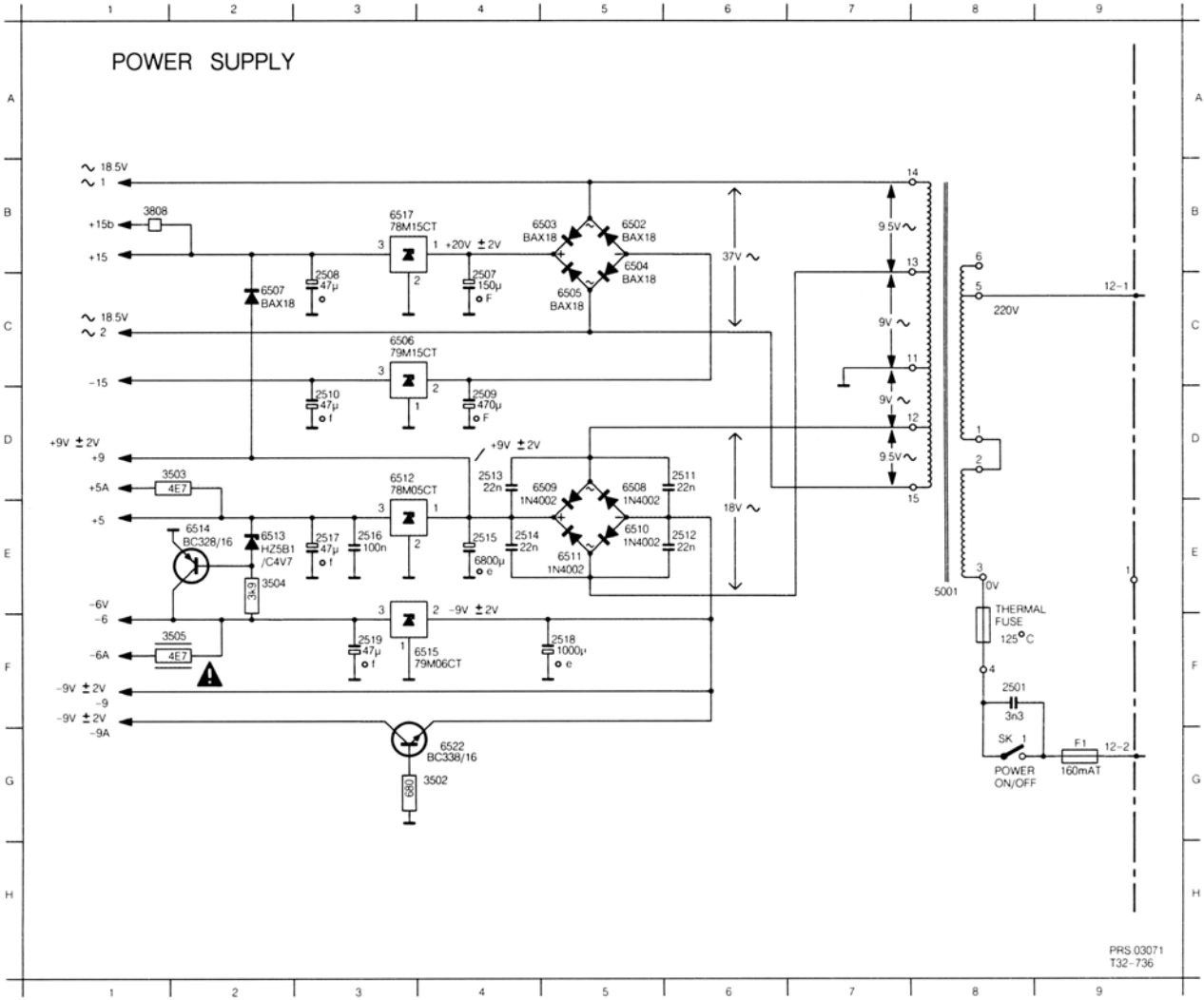

PRS 03071
132-736

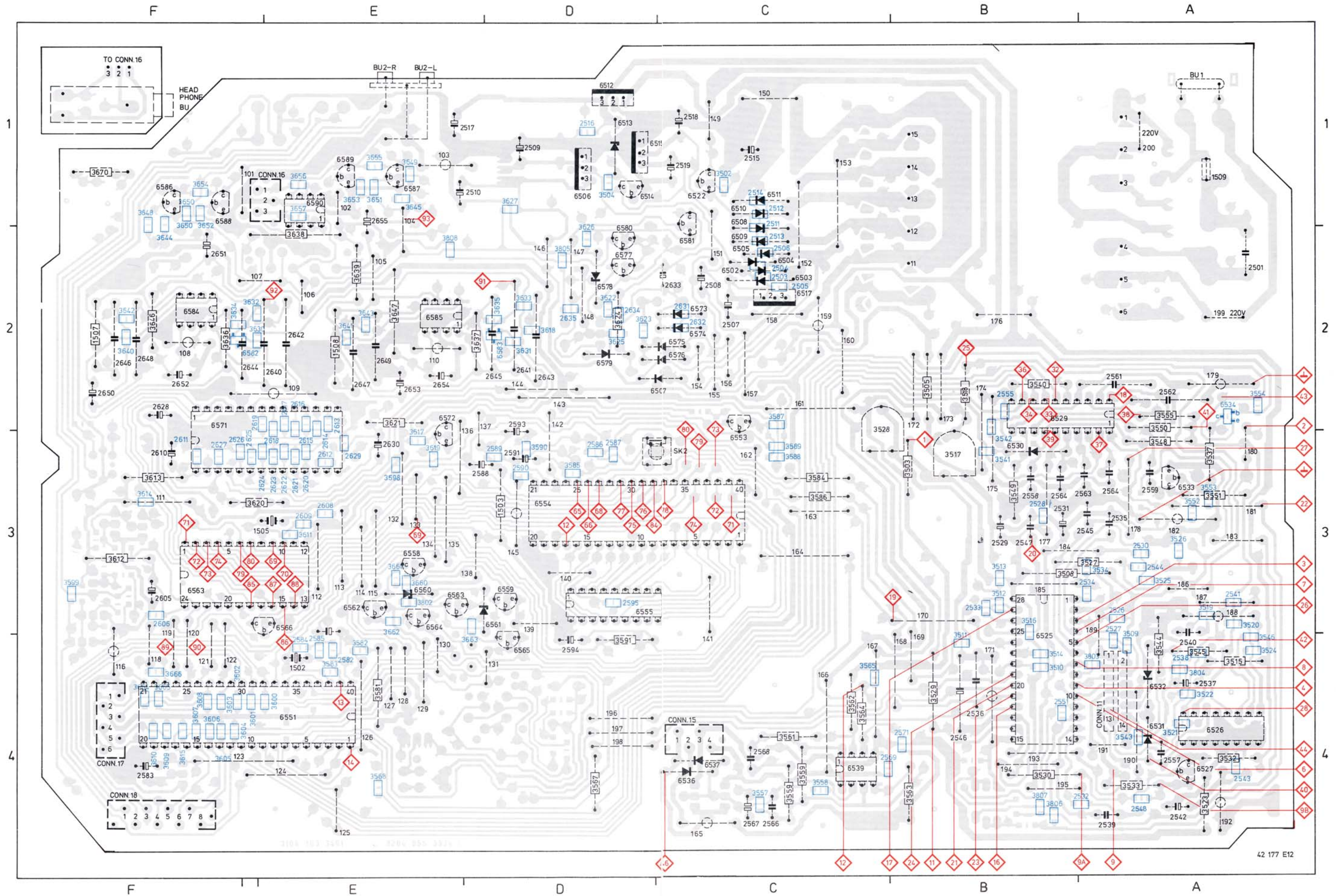

1503 L 2 2587 F 2 2590 M 4 2594 N10 2606 N18 3584 F 2 3587 H 2 3590 J 3 3600 A11 3603 B11 3606 M14 3608 B 9 3614 K20 3660 D19 3663 C18 3666 E17 6553 H 3 6558 D20 6561 C20 6563 G12 6565 C17
 1505 N14 2588 M 2 2591 G 3 2595 N 9 2608 N14 3585 F 3 3588 I 2 3591 M10 3601 B11 3604 A 6 3606 B 6 3609 B 9 3615 E 8 3661 D20 3664 C17 3802 D19 6554 E 3 6559 D19 6562 E17 6563 C18 SK-2 B13
 2586 F 2 2589 M 3 2593 J 3 2605 N19 2609 N15 3586 G 2 3589 H 3 3598 A12 3602 B11 3605 B 6 3607 B 6 3612 N18 3615 A 9 3662 C18 3665 D17 6551 B 3 6555 N 6 6560 C20 6562 B20 6564 C17

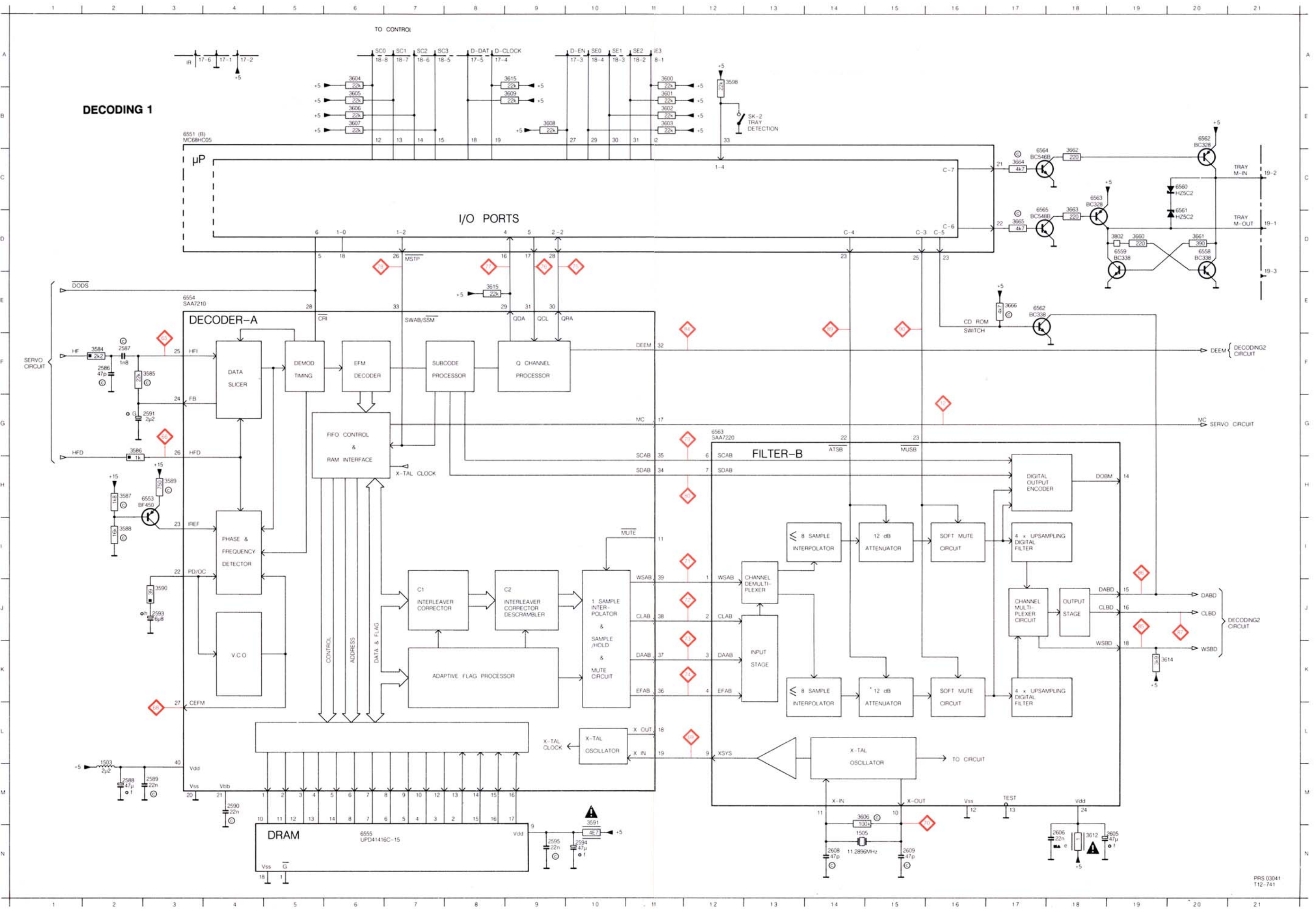

PRS 03041
 T12-741

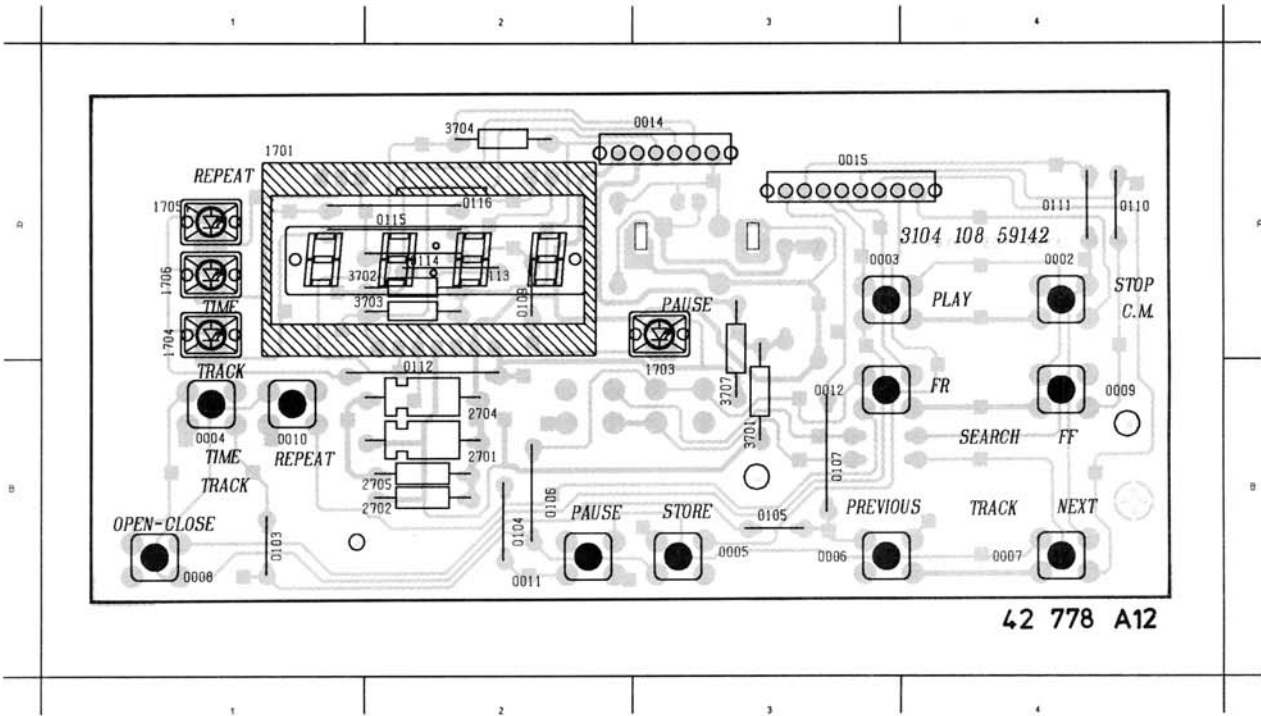

0002 A 4
0003 A 3
0004 B 1
0005 B 3
0006 B 3
0007 B 4
0008 B 1
0009 B 4
0010 B 1
0011 B 2
0012 B 3
0014 A 3
0015 A 3
1701 A 1
1703 B 3
1704 A 1
1705 A 1
1706 A 1
1706 B 2
2702 B 2
2704 B 2
2705 B 2
3701 B 3
3702 A 2
3703 A 1
3704 A 2
3707 B 3

PRS.03276
DRS. PFD
T32/042
BEH. BU 42778A

PRINCIPE DISPLAY



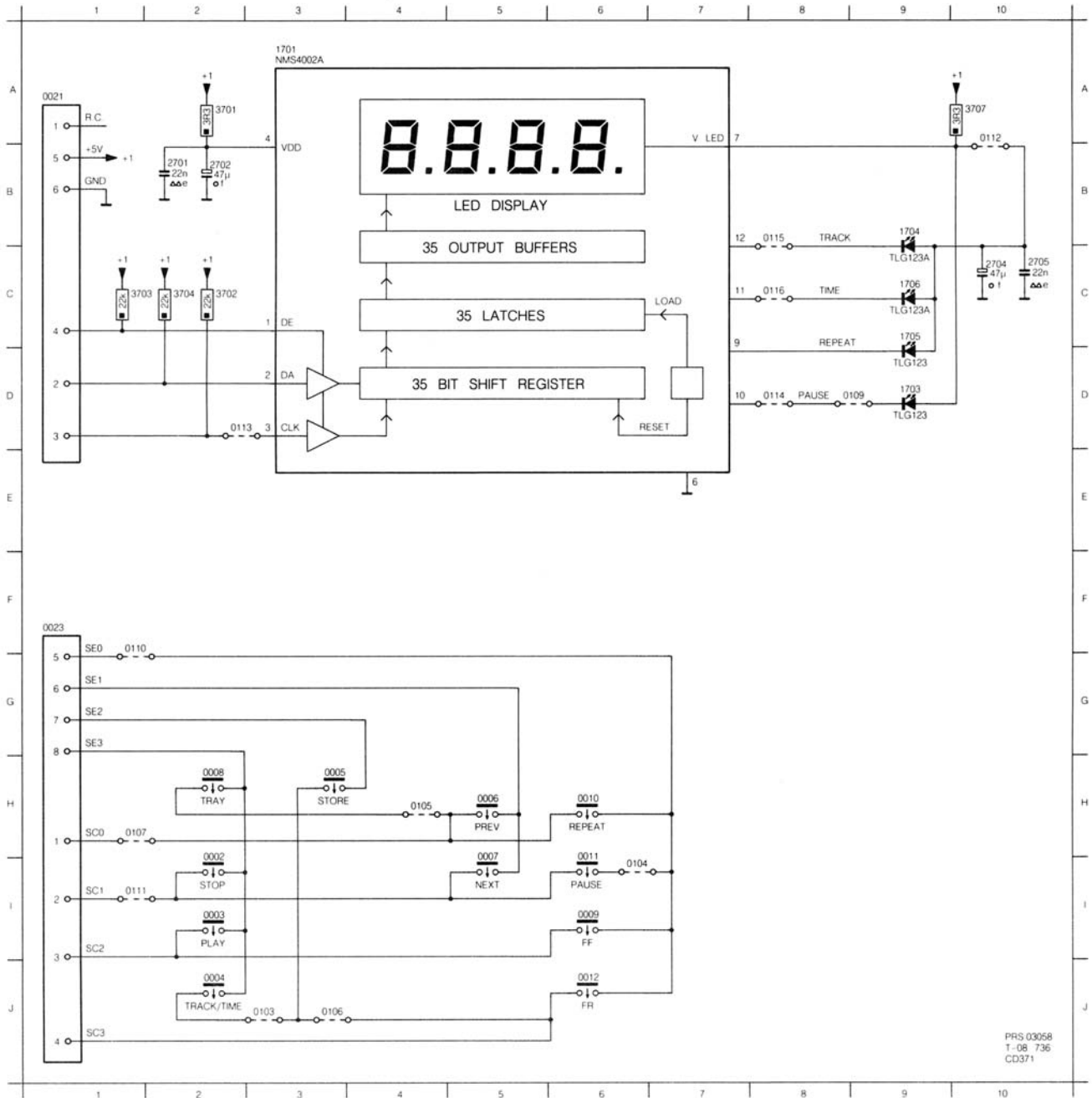



0002	H 2	0006	H 5	0010	H 6	0023	F 1	0106	J 3	0111	I 1	0115	B 8	1704	B 9	2702	B 2	3702	C 2
0003	I 2	0007	H 5	0011	H 6	0103	J 3	0107	H 1	0112	A10	0116	C 8	1705	C 9	2704	C10	3703	C 2
0004	J 2	0008	H 2	0012	J 6	0104	I 6	0109	D 9	0113	D 3	1701	A 3	1706	C 9	2705	C10	3704	C 2
0005	H 3	0009	I 6	0021	A 1	0105	H 4	0110	F 1	0114	D 8	1703	D 9	2701	B 2	3701	A 2	3707	A10

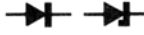

PRS 03058
T-08 736
CD371

SUPPLY + DECODER

For non active chip components see separate list

			
MC79M15CT	5322 209 86361	BAX18	4822 130 34121
MC7906CT	4822 209 82056	1N4002	5322 130 30684
TY40408 (+5 V)	4822 209 71579	1N4148	4822 130 30621
MC78M15	4822 209 80808	HZ5B1/4V7	4822 130 32986
TDA5708/C3	4822 209 83202	HZ5C2 5V1	4822 130 33293
TDA5709	4822 209 83203	HZ7C2/7V5	4822 130 32862
SAA7210P/04	4822 209 71001	BZV85 C6V2	5322 130 32962
μPD41416C-20	4822 209 50582	LED	5322 130 34957
SAA7220	4822 209 11157		
TDA1541/N5	4822 209 70295		
LM833	4822 209 72031		
NJM4560D	4822 209 83274	CSA4.000MG	4822 157 51193
L272BH	4822 209 72026	11289.6 kHz	4822 242 71644
MC68HC05C4	482 2209 72236		
MM58348	4822 209 72122		
		Coil 470 μH	4822 157 51193
BC328-16	4822 130 41023		
BC328	4822 130 44104		
BC338	4822 130 44121	Bip 2M2 50 V	4822 124 22341
BC548B	4822 130 40937	Bip 100M 16 V	4822 124 22339
BC548C	4822 130 44196		
BC558B	4822 130 44197		
BC858B	5322 130 41983	1R	4822 111 30483
BF450	4822 130 44237	4R7	4822 111 30499
BSR56	4822 130 42633	10R	4822 111 30508
		12R	4822 111 30511
		18R	4822 111 30515
		33R	4822 111 30522
		1K8	4822 116 53104
-Miscellaneous-			
Display	4822 130 90474		
Cinch socket	4822 267 40766	3517 22K	4822 100 20522
Tackt switch (for main panel)	4822 276 11276	3528 1K	4822 100 10874
Mains switch	4822 276 11309		
Mains inlet	4822 265 20291		
Transformer, mains	4822 146 30623		

Ⓢ Chips 50 V NP0 S1206				Ⓢ Chips 0,125 W S1206				Ⓢ Chips 0,125 W S1206				1T
1 pF	5%	4822 122 32479		4,7 E	5%	5322 111 90376		6,8 k	2%	4822 111 90544		
1,5 pF	5%	4822 122 31792		5,1 E	5%	4822 111 90393		7,5 k	2%	4822 111 90276		
1,8 pF	5%	4822 122 32087		5,6 E	5%	4822 111 90394		8,2 k	2%	5322 111 90118		
2,2 pF	5%	4822 122 32425		6,2 E	5%	4822 111 90395		9,1 k	2%	4822 111 90373		
3,3 pF	5%	4822 122 32079		6,8 E	5%	4822 111 90254		10 k	2%	4822 111 90249		
3,9 pF	5%	4822 122 32081		7,5 E	5%	4822 111 90396		11 k	2%	4822 111 90337		
4,7 pF	5%	4822 122 32139		8,2 E	5%	4822 111 90397		12 k	2%	4822 111 90253		
5,6 pF	5%	4822 122 32506		9,1 E	5%	4822 111 90398		13 k	2%	4822 111 90509		
6,8 pF	5%	4822 122 32507		10 E	2%	5322 111 90095		15 k	2%	4822 111 90196		
8,2 pF	5%	4822 122 32083		11 E	2%	4822 111 90338		16 k	2%	4822 111 90346		
10 pF	5%	4822 122 31971		12 E	2%	4822 111 90341		18 k	2%	4822 111 90238		
12 pF	5%	4822 122 31756		13 E	2%	4822 111 90343		20 k	2%	4822 111 90349		
15 pF	5%	4822 122 32504		15 E	2%	4822 111 90344		22 k	2%	4822 111 90251		
18 pF	5%	4822 122 31769		16 E	2%	4822 111 90347		24 k	2%	4822 111 90512		
22 pF	10%	4822 122 31837		18 E	2%	5322 111 90139		27 k	2%	4822 111 90542		
27 pF	5%	4822 122 31966		20 E	2%	4822 111 90352		30 k	2%	4822 111 90216		
33 pF	5%	4822 122 31756		22 E	2%	4822 111 90186		33 k	2%	5322 111 90267		
39 pF	5%	4822 122 31972		24 E	2%	4822 111 90355		36 k	2%	4822 111 90514		
47 pF	5%	4822 122 31772		27 E	2%	5322 111 90105		39 k	2%	5322 111 90108		
56 pF	5%	4822 122 31774		30 E	2%	4822 111 90356		43 k	2%	4822 111 90363		
68 pF	5%	4822 122 31961		33 E	2%	4822 111 90357		47 k	2%	4822 111 90543		
82 pF	10%	4822 122 31839		36 E	2%	4822 111 90359		51 k	2%	5322 111 90274		
100 pF	5%	4822 122 31765		39 E	2%	4822 111 90361		56 k	2%	4822 111 90573		
120 pF	5%	4822 122 31766		43 E	2%	5322 116 90125		62 k	2%	5322 111 90275		
150 pF	5%	4822 122 31767		47 E	2%	4822 111 90217		68 k	2%	4822 111 90202		
180 pF	2%	4822 122 31794		51 E	2%	4822 111 90365		75 k	2%	4822 111 90574		
220 pF	5%	4822 122 31965		56 E	2%	4822 111 90239		82 k	2%	4822 111 90575		
270 pF	5%	4822 122 32142		62 E	2%	4822 111 90367		91 k	2%	5322 111 90277		
330 pF	10%	4822 122 31642		68 E	2%	4822 111 90203		100 k	2%	4822 111 90214		
390 pF	5%	4822 122 31771		75 E	2%	4822 111 90371		110 k	2%	5322 111 90269		
470 pF	5%	4822 122 31727		82 E	2%	4822 111 90124		120 k	2%	4822 111 90568		
560 pF	5%	4822 122 31773		91 E	2%	4822 111 90375		130 k	2%	4822 111 90511		
680 pF	5%	4822 122 31775		100 E	2%	5322 111 90091		150 k	2%	5322 111 90099		
820 pF	5%	4822 122 31974		110 E	2%	4822 111 90335		160 k	2%	5322 111 90264		
1 nF	10%	5322 122 31647		120 E	2%	4822 111 90339		180 k	2%	4822 111 90565		
1,2 nF	5%	4822 122 31807		130 E	2%	4822 111 90164		200 k	2%	4822 111 90351		
1,5 nF	10%	4822 122 31781		150 E	2%	5322 111 90098		220 k	2%	4822 111 90197		
1,8 nF	10%	4822 122 32153		160 E	2%	4822 111 90345		240 k	2%	4822 111 90215		
2,2 nF	10%	4822 122 31644		180 E	2%	5322 111 90242		270 k	2%	4822 111 90302		
2,7 nF	10%	4822 122 31783		200 E	2%	4822 111 90348		300 k	2%	5322 111 90266		
3,3 nF	10%	4822 122 31969		220 E	2%	4822 111 90178		330 k	2%	4822 111 90513		
3,9 nF	10%	4822 122 32566		240 E	2%	4822 111 90353		360 k	2%	4822 111 90515		
4,7 nF	10%	4822 122 31784		270 E	2%	4822 111 90154		390 k	2%	4822 111 90182		
5,6 nF	10%	4822 122 31916		300 E	2%	4822 111 90156		430 k	2%	4822 111 90168		
6,8 nF	10%	4822 122 31976		330 E	2%	5322 111 90106		470 k	2%	4822 111 90161		
10 nF	10%	4822 122 31728		360 E	1%	4822 111 90288		510 k	2%	4822 111 90364		
12 nF	10%	5322 122 31648		360 E	2%	4822 111 90358		560 k	2%	4822 111 90169		
15 nF	10%	4822 122 31782		390 E	2%	5322 111 90138		620 k	2%	4822 111 90213		
18 nF	10%	4822 122 31759		430 E	2%	4822 111 90362		680 k	2%	4822 111 90368		
22 nF	10%	4822 122 31797		470 E	2%	5322 111 90109		750 k	2%	4822 111 90369		
27 nF	10%	4822 122 32541		510 E	2%	4822 111 90245		820 k	2%	4822 111 90205		
33 nF	10%	4822 122 31981		560 E	2%	5322 111 90113		910 k	2%	4822 111 90374		
47 nF	10%	4822 122 32542		620 E	2%	4822 111 90366		1 M	2%	4822 111 90252		
56 nF	10%	4822 122 32183		680 E	2%	4822 111 90162		1,1 M	5%	4822 111 90408		
100 nF	10%	4822 122 31947		750 E	2%	5322 111 90306		1,2 M	5%	4822 111 90409		
180 nF	10%	4822 122 32915		820 E	2%	4822 111 90171		1,3 M	5%	4822 111 90411		
220 nF	20%	4822 122 32715		910 E	2%	4822 111 90372		1,5 M	5%	4822 111 90412		
Ⓢ Chips 0,125 W S1206 NP0				1 k	2%	5322 111 90092		1,6 M	5%	4822 111 90413		
0 E	jumper	4822 111 90163		1,1 k	2%	4822 111 90336		1,8 M	5%	4822 111 90414		
1 E	5%	4822 111 90184		1,2 k	2%	5322 111 90096		2 M	5%	4822 111 90415		
1,1 E	5%	4822 111 90377		1,3 k	2%	4822 111 90244		2,2 M	5%	4822 111 90185		
1,2 E	5%	4822 111 90378		1,5 k	2%	4822 111 90151		2,4 M	5%	4822 111 90416		
1,3 E	5%	4822 111 90379		1,6 k	2%	5322 111 90265		2,7 M	5%	4822 111 90417		
1,5 E	5%	4822 111 90381		1,8 k	2%	5322 111 90101		3 M	5%	4822 111 90418		
1,6 E	5%	4822 111 90382		2 k	2%	4822 111 90165		3,3 M	5%	4822 111 90191		
1,8 E	5%	4822 111 90383		2,2 k	2%	4822 111 90248		3,6 M	5%	4822 111 90419		
2 E	5%	4822 111 90384		2,4 k	2%	4822 111 90289		3,9 M	5%	4822 111 90421		
2,2 E	5%	5322 111 90104		2,7 k	2%	4822 111 90569		4,3 M	5%	4822 111 90422		
2,4 E	5%	4822 111 90385		3 k	2%	4822 111 90198		4,7 M	5%	4822 111 90423		
2,7 E	5%	4822 111 90386		3,3 k	2%	4822 111 90157		5,1 M	5%	4822 111 90424		
3 E	5%	4822 111 90387		3,6 k	2%	5322 111 90107		5,6 M	5%	4822 111 90425		
3,3 E	5%	4822 111 90388		3,9 k	2%	4822 111 90571		6,2 M	5%	4822 111 90426		
3,6 E	5%	4822 111 90389		4,3 k	2%	4822 111 90167		6,8 M	5%	4822 111 90235		
3,9 E	5%	4822 111 90391		4,7 k	2%	5322 111 90111		7,5 M	5%	4822 111 90427		
4,3 E	5%	4822 111 90392		5,1 k	2%	5322 111 90268		8,2 M	5%	4822 111 90237		
				5,6 k	2%	4822 111 90572		9,1 M	5%	4822 111 90428		
				6,2 k	2%	4822 111 90545		10M	5%	5322 111 91141		

SYMBOL	DESCRIPTION
	Operational amplifier
	Differential amplifier
	Splitter
	Operational amplifier with open output
	Exclusive OR gate
	True/complement amplifier with high input
	Flip Flop
	AND gate
	OR gate
	Inverter with high input

	0.2W (CR 16)		220k Ω 5% 270k Ω 10%
	0.33W (CR 25)		1M Ω 5% 1M Ω 10%
	0.33W (SFR25)		5%
	0.25W (VR 25)		10M Ω .5% 10M Ω 10%
	0.5W (CR 37)		1M Ω 5% 1M Ω 10%
	0.67W (CR 52)		5%
	1.15W (CR 68)		5%
	Ceramic plate		
	Polyester flat foil		
	Polyester mepolesco		
	Mylar (Polyester flat foil small sized)		
	Micropoco		
	Tubular ceramic (body colour pink or yellow/green)		
	Miniature single elco		
	Subminiature tantalum		

* a=2.5V
 b=4V
 c=6.3V
 d=10V
 e=16V
 f=25V
 g=40V
 h=63V
 i=100V
 j=125V
 l=125V
 m=150V
 n=160V
 q=200V
 r=250V
 s=300V
 t=350V
 u=400V
 v=500V
 w=630V
 x=1000V
 A=1.6V
 B=6V
 C=12V
 D=15V
 E=20V
 F=35V
 G=50V
 H=75V
 I=80V

MDA 00084
 T32-735

SYMBOL	DESCRIPTION
	Capacitor, general
	Electrolytic capacitor (+ and - may be omitted)
	Bipolar electrolytic capacitor (+ may be omitted)
	Resistor, general
	N.T.C. resistor
	P.T.C. resistor
	Voltage divider with preset adjustment
	Chip jumper
	Pin contact
	Bus contact
	Coil, self-induction
	Transformer with electrically poor conducting core and adjustable pre-magnetization
	Diode
	Zener diode
	Stabistor
	Double variable capacity diode (in one envelope)
	Photoconductive diode
	LED

SYMBOL	DESCRIPTION
	Transistor (N.P.N.)
	Transistor (P.N.P.)
	Direct current (DC)
	Alternating current (AC)
	Earth (functional)
	Frame or chassis connection
	Direction in which AC voltages are passed on (optional present)
	Interrupted line
	Not-connected crossing lines
	Connected lines
	Cable tree with lead-outs
	Changer, general (arrow is optional)
	Voltage Controlled Oscillator
	Band-pass filter
	Phase changing network
	Delay element
	Amplifier, general

Due to the introduction of CDM-4 (from AH01on) the following pages have been added to the service manuals. Note A separate manual for the CDM-4 will not be published. Therefore these pages are added to the existing manual.

Change sheets:

1-1-a
6-2-a

Supplementary sheets:

7-1 Changes
8-1 Laser adjustment for CDM-4
8-3 Technical Data
8-4 Servicing hints
8-5 Servicing hints
8-6 Measurements and adjustments
8-7 Measurements and adjustments
8-8 Exploded view
8-9 Motor circuit

Service
Service
Service

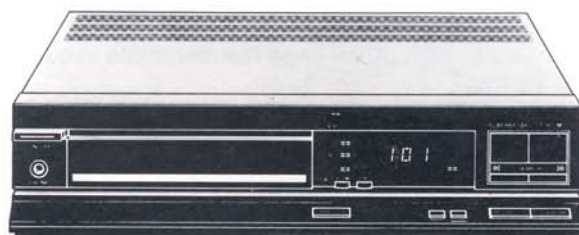

For repair of the CDM mechanism with serialnumber AH00 see Service Manual CDM-2-0500.

For serialnumber AH01 and on, see chapter 8.

Service Manual

COMPACT
disc
DIGITAL AUDIO

CONTENTS

- 1 Explanation subdivision and table of contents per page
- 2 Controls and technical specifications
- 3 Servicing hints
- 4 Measurements and adjustments
- 5 Exploded views and parts lists of mechanical components
- 6 Block diagram, circuit diagrams, PCB data, parts lists of electrical components and wiring diagram
- 7 Changes
- 8 Additional information

Safety regulations require that the set be restored to its original condition and that parts which are identical with those specified be used.

**CLASS 1
LASER PRODUCT**

3122 110 03420

Documentation Technique Service Dokumentation Documentazione di Servizio Huolto-Ohje Manual de Servicio Manual de Serviço



Subject to modification
(GB) 4822 725 21605
Printed in The Netherlands
© Copyright reserved

PHILIPS

Published by Service
Consumer Electronics

CS 13 879 GB

1. EXPLANATION ON THE LAYOUT OF THE DOCUMENTATION

The documentation consists of chapters.
The number of the chapter is indicated by the first digit of the page number.
The second digit of the page number is the sequence numbering.

If modifications or supplements require new supplementary or replacement pages, the page number is extended with a third part:

A digit behind the page number indicates that it concerns a supplementary page.

A replacement page is indicated by a letter behind the page number.

Example

3-6	is page 6 of chapter 3
3-6-1	is a supplementary page behind page 3-6
3-6-a	is the replacement page of page 3-6 (so page 3-6 can be removed from the documentation).

TABLE OF CONTENTS PER PAGE

Chapter	Page	Contents
1	1-1-a	Explanation of the subdivision of the documentation Table of contents per page
2	2-1	Controls
	2-2	Technical specification
3	3-1	Servicing hints
	3-2	Disassembly of top cover Servicing of front panel Servicing of tray mechanism Disassembly of CDM Servicing of servo + decoder panel Replacement of transformer fuse
4	4-1	Electrical measurements and adjustments General checkpoints
	4-2	General checkpoints
	4-3	Detailed measuring method
	4-4	Detailed measuring method
	4-5	Detailed measuring method
	4-6	Detailed measuring method
	4-7	Detailed measuring method
5	5-1	Exploded view tray mechanism Partslist of mechanical components
	5-2	Exploded view of cabinet + parts list of cabinet components
6	6-1	Block diagram
	6-2-a	Circuit diagram of the servo
	6-3	Circuit diagram of the power supply and Drawing of the servo + decoder panel
	6-4	Drawing of the servo + decoder panel
	6-5	Circuit diagram of decoder 1
	6-6	Drawing of the control and display panel and its circuit diagram
	6-7	Circuit diagram of decoder 2
	6-8	Wiring diagram
	6-9	Electrical partslist Partslist lead-less components
	6-10	Survey standard symbols
7	7-1	Changes
8	8-1	Laser adjustments for CDM-4
	8-3	Technical data
	8-4	Servicing hints
	8-5	Servicing hints
	8-6	Measurements and adjustments
	8-7	Measurements and adjustments
	8-8	Exploded view
	8-9	Motor circuit

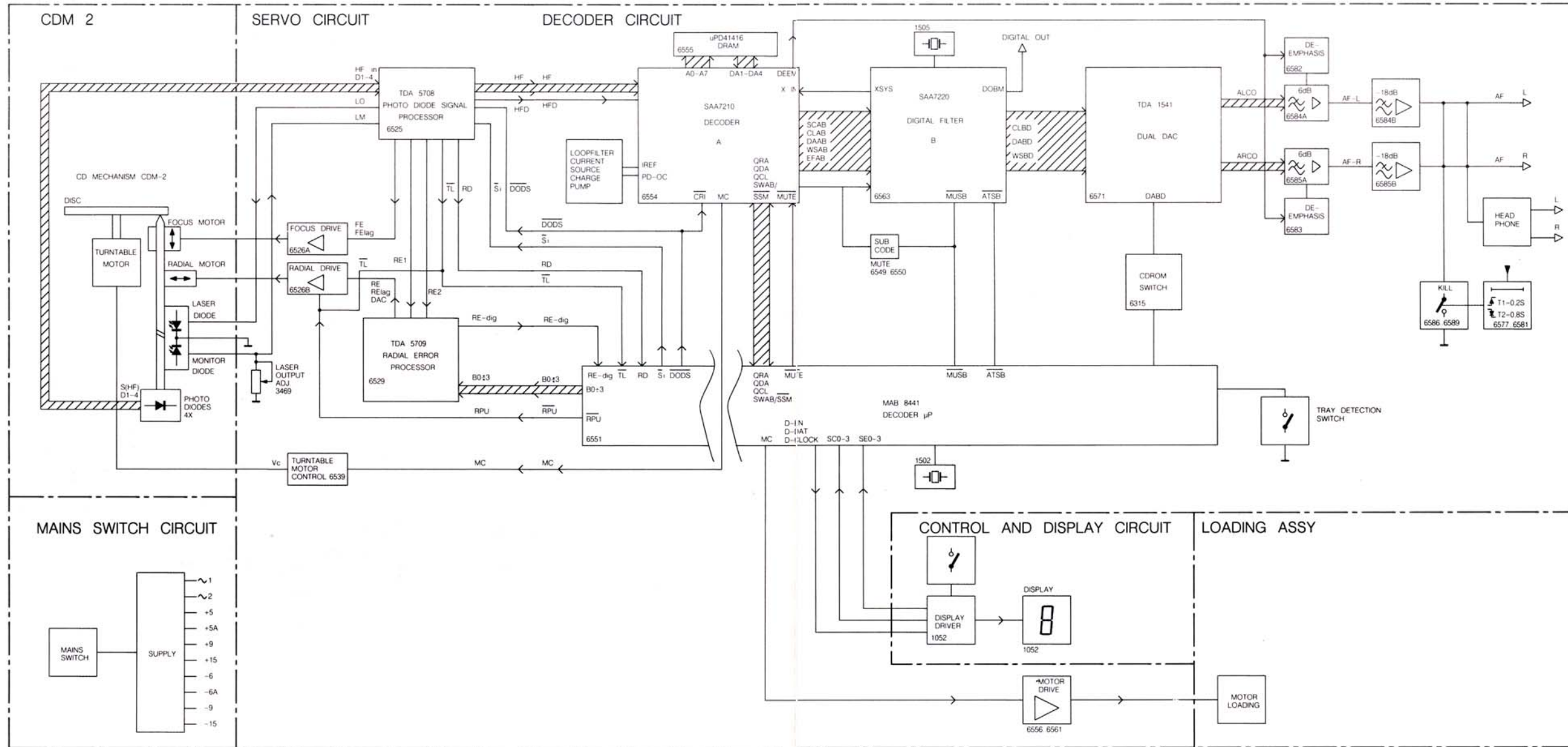

PRS 03038
112/737

BLOCK DIAGRAM

- | | | | | | | | |
|--------|--|--------|--|---------------|--|----------|--|
| B0-B3 | - Control bits for radial circuit | RE1 | - Radial error signal 1 (summation of amplified currents D_3 and D_4) | ATSB | - Attenuation of Audio level in Search position (Cueing) | MUSB | - Soft Mute signal |
| DAC | - Current output for track jumping (Digital to Analogue Converted) | RE2 | - Radial error signal 2 (summation of amplified currents D_1 and D_2) | CD ROM Switch | - Digital Data information on disc signal | QCL | - Q-channel Clock signal |
| DODS | - Drop out detector suppression | RE dig | - Radial error digital | CEFM | - Clock Eight-to-Fourteen Modulator | QDA | - Q-channel Data signal |
| D1+4 | - Photodiode currents | RE lag | - Radial error signal for LAG network | CLAB | - Clock signal Decoder-A to Filter-B | QRA | - Q-channel Request Acknowledge |
| FE | - Focus error signal | RPU | - Radial puls after track jumping | CLBD | - Clock signal Filter-B to DAC | SCAB | - Subcode clock Decoder-A to Filter-B |
| FE-lag | - Focus error signal for LAG network | Si | - On/off control for laser supply and focus circuit | CRI | - Counter Reset Inhibit | SDAB | - Subcode data Decoder-A to Filter-B |
| HF | - HF output for DEMOD | TL | - Track loss signal | DAAB | - Data signal Decoder-A to Filter-B | SWAB/SSM | - Subcode Word/Start-stop motor signal |
| HFD | - HF detector output for DEMOD | Vc | - Control voltage for turntable motor | DABD | - Clock signal Filter-B to DAC | WSAB | - Word Select Decoder-A to Filter-B |
| HF-in | - HF current input | | | DEEM | - Deemphasis | WSBD | - Word Select Filter-B to DAC |
| LM | - Laser monitor diode input | | | DOB M | - Digital out signal | XIN | - Oscillator signal in Decoder-A |
| LO | - laser amplifier current output | | | EFAB | - Error flag Decoder-A to Filter-B | XSYS | - Oscillator signal out Filter-B |
| MC | - Motor control signal | | | MSTP | - Motor start-stop signal | A0-A7 | - Adressbus A0-A7 |
| RE | - Radial error signal (amplified RE_2 - RE_1 currents) | | | MUTE | - Mute signal | | |

1001	J 1	2527	F 3	2532	F 6	2537	J12	2542	K12	2547	I 10	2556	C14	2562	I 14	2568	M16	2584	A10	3511	D 6	3516	F 6	3521	J13	3526	K10	3532	I 3	3538	D11	3543	F21	3549	F18	3554	I 17	3560	M16	3565	M14	3803	H 3	6526	J12	6532	F20	6539	M17
1002	J 1	2528	E 5	2533	F 8	2538	J13	2543	K13	2548	J 3	2557	F21	2563	I 15	2569	N15	2585	A10	3512	E 8	3517	L12	3522	K13	3527	L11	3533	J 3	3539	D18	3544	G20	3550	F19	3555	D19	3561	M16	3581	A 7	3806	H11	6527	J 3	6533	J18	6539	M15
1003	J 1	2529	E 4	2534	F 9	2539	E 7	2544	J11	2549	K13	2558	E18	2564	I 15	2571	M14	3508	F 3	3513	E 9	3518	L11	3523	K12	3528	L 3	3534	G10	3540	I 13	3545	G20	3551	G19	3557	L17	3562	L14	3582	A 9	3807	G11	6529	D12	6534	I 17	6551	B 5
1502	A10	2530	E 5	2535	F10	2540	L13	2545	L 9	2551	H11	2559	G18	2566	L17	2581	A 8	3509	F 3	3514	E 6	3519	L13	3524	K11	3529	K 3	3536	D 8	3541	C15	3546	F20	3552	J18	3558	L17	3563	M17	3583	A10	6525	I 5	6530	C14	6536	M18		
2526	F 3	2531	E 5	2536	H10	2541	K13	2546	J 4	2555	C17	2561	I 14	2567	L17	2582	A 8	3510	E 7	3515	J12	3520	L13	3525	J11	3530	J 3	3537	J17	3542	D15	3548	E19	3553	J18	3559	M16	3564	M14	3599	A11	6528	E20	6531	F20	6537	M18		

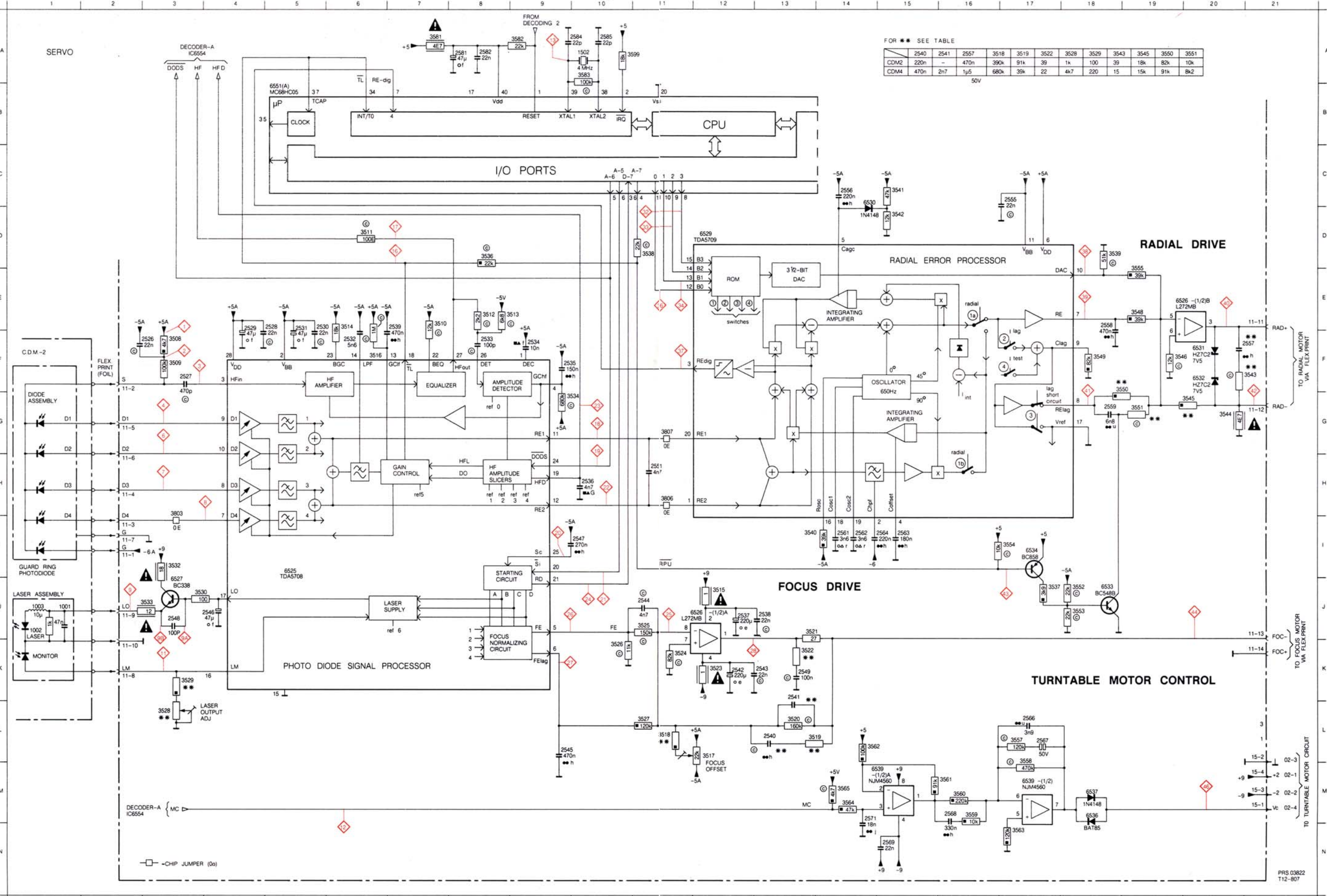

FOR ** SEE TABLE

	2540	2541	2557	3518	3519	3522	3528	3529	3543	3545	3550	3551
CDM2	220n	-	470n	390k	91k	39	1k	100	39	18k	82k	10k
CDM4	470n	2n7	1µ5	680k	39k	22	4k7	220	15	15k	91k	8k2

50V

CHANGES**Introductions with A88-105 from marking AH01**

Description		Reason
Table of contents	1-1-a	Contents adapted
Block diagram	6-1-a	Block diagram adapted
Diagram of the servo	6-2-a	Table added because of the introduction of the CDM-4
Laser adjustment	8-1	Laser current adjustment for the CDM-4
Technical data	8-3	A separate manual for the CDM-4 will not be published.
Servicing Hints	8-4	Therefore these pages are added to the existing manual.
Servicing Hints	8-5	
Measurements and adjustments	8-6	
Measurements and adjustments	8-7	
Exploded view	8-8	
Motor circuit	8-9	

Laser adjustment for CDM4

- Measure the resistance of R3529 + R3528 with an ohmmeter and adjust potentiometer R3528 so that R3528 + R3529 have a combined value of 1 k Ω .
- Check the monitor diode connections. Measure at test point 11 and ground (\perp).
- Put test disc 5 on the turntable.
- Switch on the set and select the PLAY mode or a similar service position.
- Take a DC voltmeter and measure across R3532. The voltage across this resistor should stay smaller than 1260 mV.
- Check if HF is present. If not, stop the measurement immediately and analyse the fault.
- If HF is present, play track 1 of test disc 5 and adjust the sum HF across R3508 (test points 1 and 2) to 50 mV with a DC voltmeter.
Check, during the adjustment, that the voltage across R3532 does not exceed 1260 mV.
- If the adjustment is not successful within the 1260 mV margin across R3104, check the angle setting.

2. TECHNICAL DATA

General

- Application: Compact Disc "Home Player"
- Single-stage radial and balanced actuator for track following
- Track following error detection method : Push-Pull
- Focus error detection method : Double Foucault
- Dimensions: 130 x 100 x 44 mm
- Weight : abt. 270 grams

Radial actuator

- Swing angle: 72°
- Diameter readout range: from 47.4 mm \pm 0.6 mm to 117.5 mm \pm 0.5 mm
- Squareness relative to turntable: 90° \pm 0.4°
- Bearing friction: 0.75 mNm max.
- Total ohmic resistance of the coils: 20 Ω \pm 2 Ω
- Maximum allowable voltage: 14V/DC continuous
- K factor: 0.019 Nm/A (\pm 20%)

Focus actuator

- Vertical amplitude: 1.9 mm \pm 0.2 mm
- DC voltage across the focus motor in focus: between -0.8V and +0.7V.
- Sensitivity: 21 mm/A
- Ohmic resistance: 23.5 Ω \pm 2.5 Ω
- Maximum allowable voltage: 8V/DC continuous

Laser diode LTO 22MC

- Wave length: 780 nm \pm 10 nm
- Light energy: 3 mW
- Voltage across the diode at 3mW: typical = 1.75 V, max. = 2.2 V

Turntable motor

- Hall motor

3. SERVICING HINTS

To prevent loose metal objects from getting in the CD mechanism, it will be necessary to see to a clean repair station.

The objective can be cleaned with a blow brush.

When effecting repairs to, or making measurements on the CD mechanism, be careful not to damage the flat springs of the focusing unit.

ESD



THE PHOTODIODES AND THE LASER ARE MORE SENSITIVE TO ELECTROSTATIC DISCHARGES THAN MOS ICS.

CARELESS HANDLING DURING SERVICING MAY REDUCE LIFE EXPECTANCY DRASTICALLY. FOR THIS REASON CARE SHOULD BE TAKEN THAT DURING SERVICING THE POTENTIALS OF THE AIDS AND YOURSELF ARE EQUAL TO THAT OF THE SCREENING OF THE SET.

For measurements and adjustments it is possible to position the working mechanism outside the set. For this purpose, an extension cable can be made from the following parts.

- Service flat cable (14-pole) 4822 322 40066
- Service connector (14-pole) 4822 290 60602

These two items should be used to assemble an extension cable between the connector and the flex cable of the CDM-4 unit. The two connections to the motor should be lengthened with loose wires.

Remark: The service cable should be assembled as follows; (see Fig. 1)

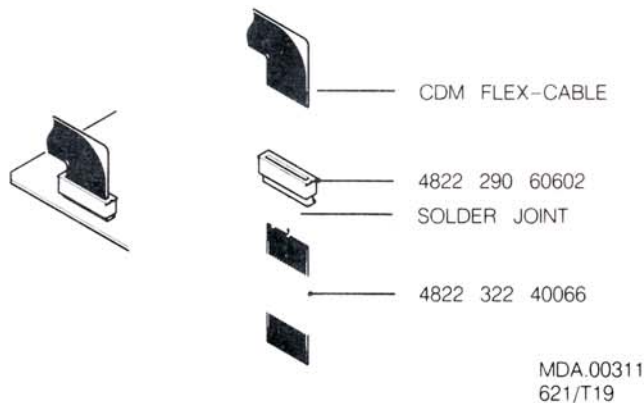

Fig. 1.

Service aids

- Audio test disc 4822 397 30085
- Disc without errors + Disc with DO errors, black spots and fingerprints 4822 397 30096
- Disc hold-down see page 3-2
- Torx screwdrivers
- Set (straight) 4822 395 50145
- Set (square) 4822 395 50132
- Glass disc 4822 395 90204

Demounting the Rafoc unit

- Take the CD-mechanism out of the set.
- Remove the flexible PCB from the connector on the PCB by lifting the upper part of the connector and taking the flexible PCB out. (see Fig. 2)

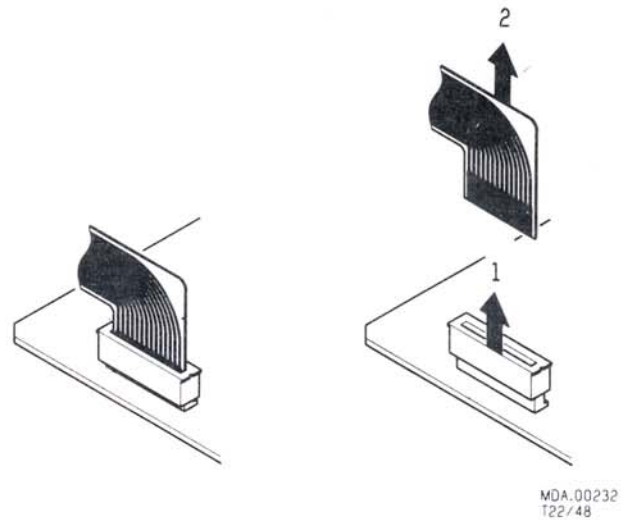

Fig. 2

- The RAFOC unit can be removed after the two fixing screws M3 x 25 have been loosened. **Caution:** when doing so, the two nuts M3 on the upper side of the CD mechanism come loose.
- Now the pivot plate, item no. 56, can be removed.
- After removing the clamping piece, item no. 51, the RAFOC unit/flexible PCB assembly can be taken out. **Attention:** when mounting the RAFOC unit, see to it that the flexible PCB reset well against the mounting plate at the height of the clamping piece (item no. 51). In some cases, after exchanging the RAFOC unit/flexible PCB assembly, it may be necessary to glue the flexible PCB with a fast-drying glue to prevent the RAFOC unit from rubbing against the flexible PCB. The glueing should be done very carefully.
- When the laser and/or the monitor diodes are defective, it will be necessary to replace the complete CDM unit.
- After mounting the RAFOC unit you should make sure that the arm runs clear over the entire disc diameter. This can be checked by means of a spring-pressure gauge which is held against the magnet of the focusing unit. The friction of the arm, measured over the entire meter reading, may not be greater than 25mN.
- A fast check of the clearance of the arm is possible in service position 0. For servicing positions see the service manual of the set.
- After mounting, the angle setting should be adjusted.

Replacing the flexible PCB item 54

- Demount the RAFOC unit.
- Desolder the connections A (see Fig. 3) of the flexible PCB.

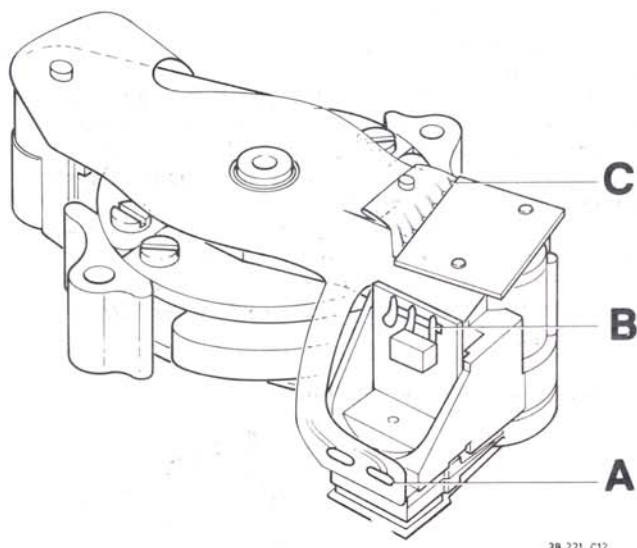

Fig. 3

- Before desoldering the connections C of the photodiode PCB, the positions of the connecting points of the photodiode PCB should be marked, so that afterwards the PCB can correctly be replaced.
- Now the 6 connections C of the photodiode PCB can be desoldered by heating the pins C one by one until the flexible PCB comes loose. This should be done very carefully.
- Desolder the 4 connections of the radial coils.

Mounting the flexible PCB (item 54).

- Solder the 4 connections of the radial coils.
- Apply the connections A and B (see Fig. 3).
- Before the 6 connections of the photodiode PCB can be soldered, they should be provided with an extra coating of tin.
- Place the flexible PCB under the photodiode PCB.
- In order to hold this position, the flexible PCB may be supported (for example by an expanded paper-clip between the arm and the underside of the flexible PCB).
- Then the 6 connections C can be heated so that they become soldered to the photodiode PCB.

Replacing electrical components

- If one of the following components is defective: photodiodes, laser diode, focus motor, radial actuator turntable motor, the entire CDM unit should be replaced.

A service disc-holddown

The disc should always bed down well on the turntable. If the mechanism has to be dismantled for repair, a service disc-holddown should be used. The CD mechanism then can function normally as in the set.

Compose a service Disc hold-down in the following way

- Cut in the most inner ring of a disc hold-down (4822 462 56383) with small and sharp nippers. See fig. below.
- Enlarge the diameter of the innermost ring slightly with the hind part of a pencil of ballpoint, so that it jams onto the turntable with sufficient force.
- If the jamming force decreases after certaintime of use, the diameter has to be enlarged with a pencil or ballpoint again.

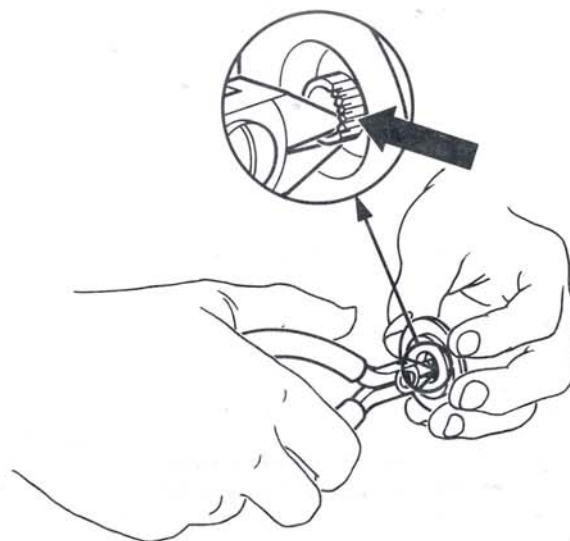

Replacing chip components

Leadless components have been applied in the set. For the insertion and removal of leadless components see the figure on page 3-1.

4. MEASUREMENTS AND ADJUSTMENTS

Checking the angle setting

The angle setting can be checked with the glass-disc method which is explained below.

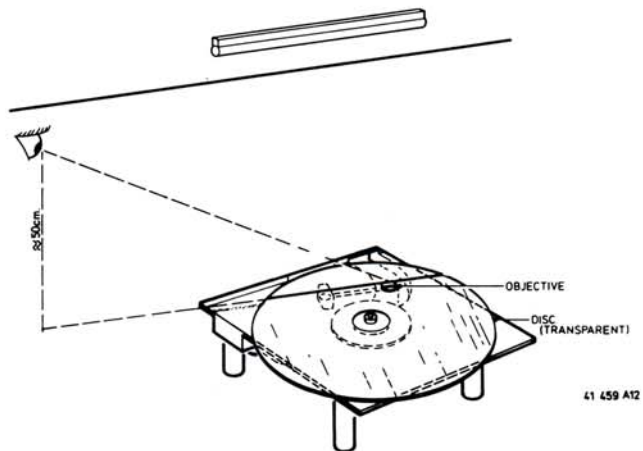

Fig. 4

Put glass disc 4822 395 90204 on the turntable. Make sure that the glass disc beds down well on the turntable. Place the CD mechanism under a light source, under which there is a straight line (e.g. under a fluorescent tube with grid). Set the arm to mid-position of its radial track. Turn the mechanism until the arm is parallel to the line under the light source (see figure below). Look into the direction and in the extension of the line to the reflection there of on the glass disc and in the objective. Locate the CDM in such a way that the line reflected by the glass disc runs across the centre of the objective. The line reflected by the objective should fall just within the surface of the objective. If this is the case, the two lines are not more than 4 mm apart and squareness is correct.

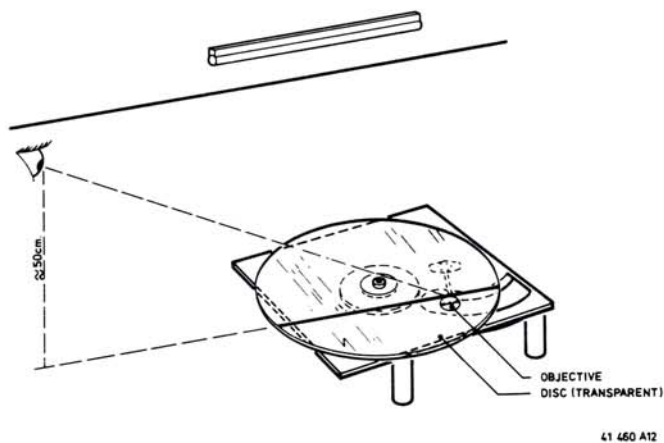

Fig. 5

Turn the CD mechanism through 90° relative to the previous position. The arm must be kept in mid-position (see figure above). Repeat the previous check.

Adjusting the angle setting

For adjusting the angle setting one or both of the two locking knocks for the bearing plate on pos. 59 must be broken.

If a check on the angle setting shows that the angle falls outside the tolerance, the angle should NOT be adjusted for minimum deviation, but it should be adjusted within the tolerance.

The new setting should lie between the old setting and the optimum setting. After adjusting the setting, the friction of the arm must be checked. This is done by means of a spring pressure gauge which is held against the magnet of the focusing unit.

The friction of the arm, measured over the entire meter reading, should not be greater than 25 mN.

When the friction appears to be too high, the RAFOC unit must be replaced and the angle between disc and light path adjusted.

The lock is adjusted as follows:

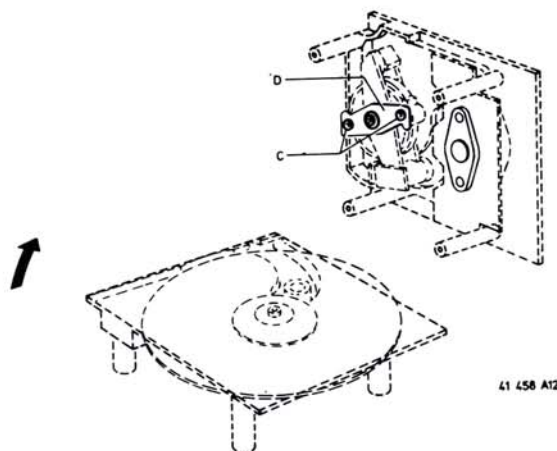

Fig. 6

Loosen screws C (see figure above) until bearing plate D can be displaced. Correct the angle setting by moving the bearing plate into the direction shown in figure below. Tighten screws C, ensuring that the setting does not drift. Then double check the setting in two directions.

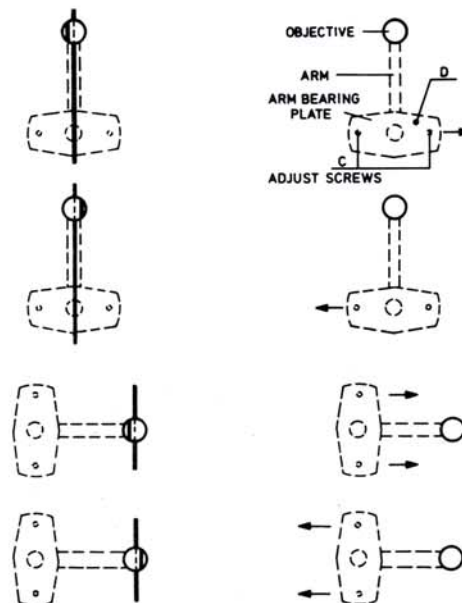

Fig. 7

Check of the motor control (Hall control)
(see motor PCB)

Principle

With the oscilloscope the form of the voltage across resistor 3094 in the +2 lead and across resistor 3093 in the -2 lead is seen. This voltage is a consequence of the current and in this way current signals (pictures) are formed.

The current through the motor-coils A and B is sinusoidal. This current is switched on and controlled by the Hall ICs.

The Hall ICs are mounted at an angle of 90 degrees with respect to each other. Consequently the currents through A and B are shifted in phase 90 degrees.

In the following figures the origin of the current signal through the +2 and -2 leads is shown graphically.

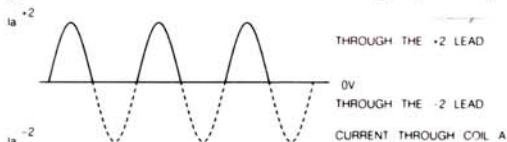

FIG 1

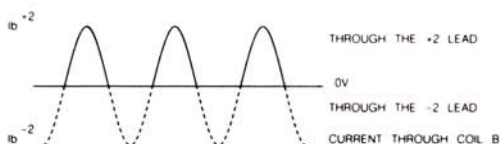

FIG 2

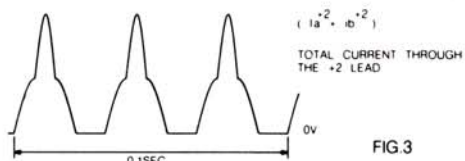
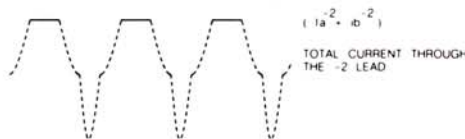

FIG 3



MDA 00336
T32-646

SERVO P.C.B

MOTOR P.C.B

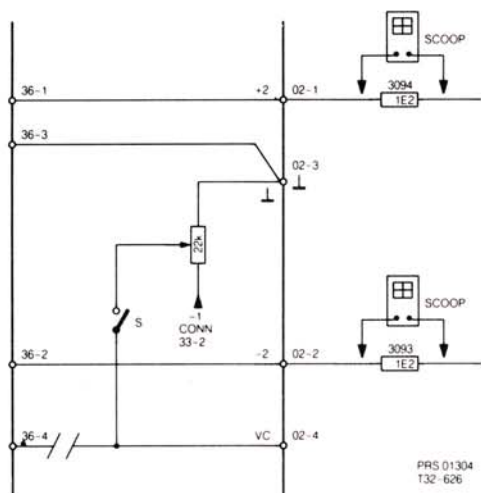

PRS 01304
T32-626

1. Interrupt the Vc connection by unsoldering the connector point 36-4 on the servo + preamplifier p.c.b.
2. Connect a trimming potentiometer of 22K Ohm to the motor print between 02-3() and connector 33-2(-1) on the servo board.

3. Connect the slider with 02-4(Vc) via switch S.
4. Measure with an oscilloscope first across 3094 and hereafter across 3093.
Do not measure across both resistors at the same time, since the currents are measured through the +2 lead and -2 lead.
5. Put the trimming potentiometer in the maximum position (the slider is then connected to connector 33-2(-1)).
6. With a disc on the turntable, put the set in service-loop 0. Switch S on and adjust the trimming potentiometer back in such a way that 3 complete pulses are visible during 0.1 sec. (fig. 3). The polarity of the oscilloscope must be chosen so that the tops of the pulses are in upward position.
The rotor magnet of the motor has 3 polespairs. Therefore the behaviour of the motor during one revolution with a speed of 600 r.p.m. is visible.
7. Measure with a DC-voltmeter on 02-4(Vc).
A. $V_c = -1.7 \pm 0.5$ V.
B. Measure across 3094, value 1 = maximum 56.4 mV.
C. Measure across 3093, value 2 = maximum 58.8 mV.
D. Difference: (value 1 - value 2) maximum 6 mV. If the difference exceeds 6 mV, while value 1 and value 2 are below the maximum the motor is then wrong!

8. For a good functioning the signal has to meet the following values:

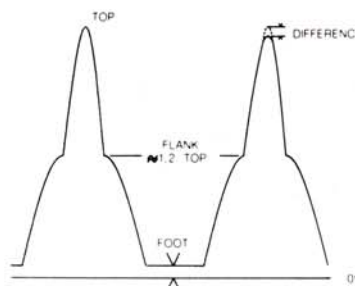

MDA 00337
T32-626

- Top is not specified by value, see 7 (value 1 and value 2).
- Top difference < 24 mV
- Flank difference < 36 mV
- Foot is not specified

Remark:
Flank difference is at one asymmetrical pulse.
Foot is DC offset.

9. Examples of the wave form faults:

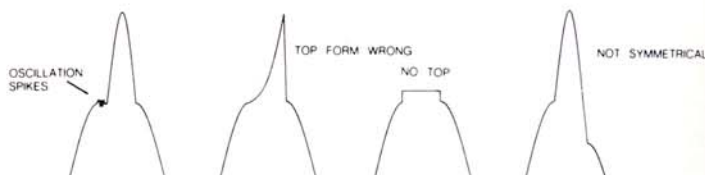

MDA 00338
T32-626

10. Adjust the voltage on 02-4(Vc) with the potentiometer back to -0,9 V. The motor must still turn. Although the top height is much lower now the wave form has to be symmetrical and rounded.

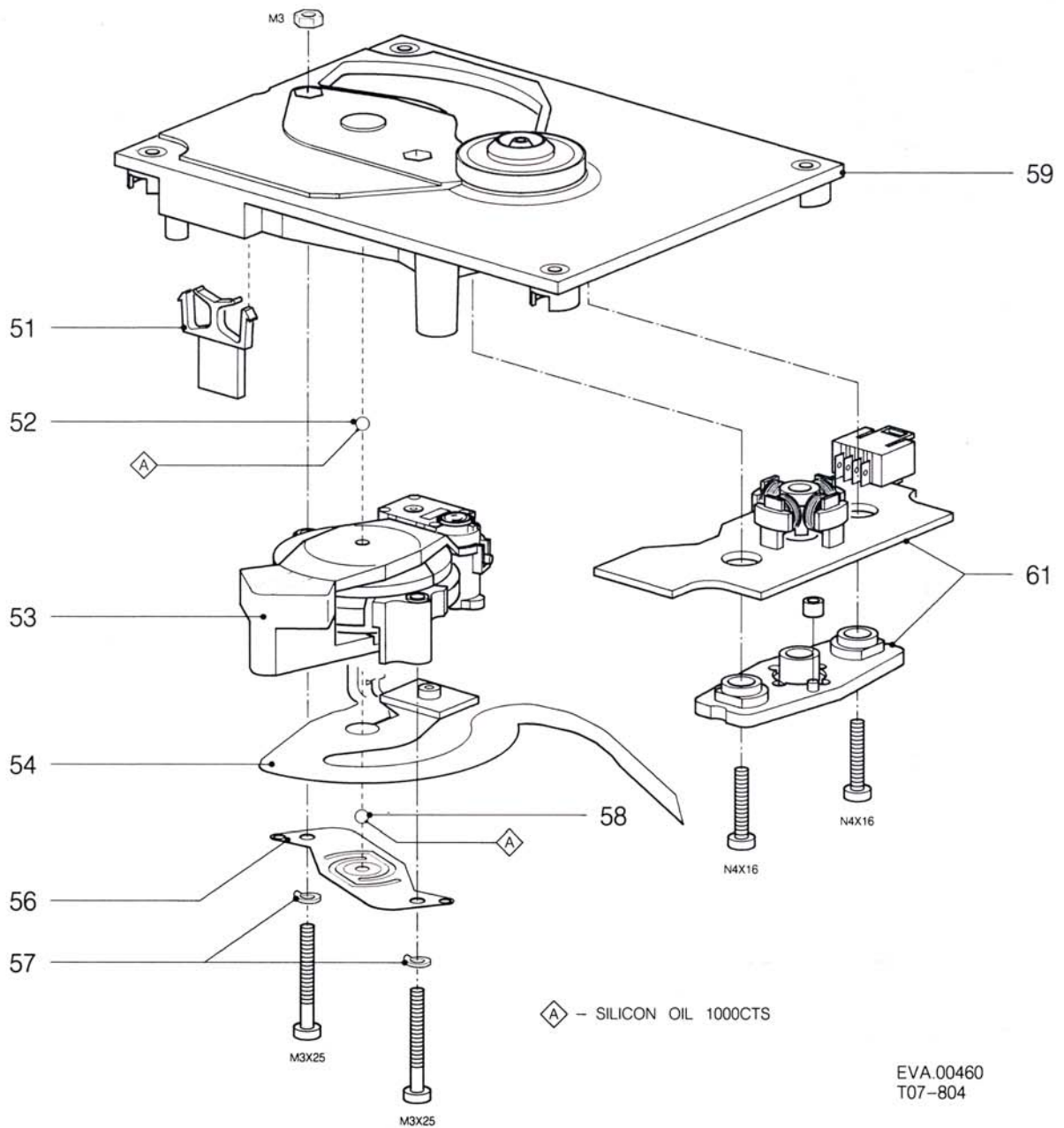

Mechanism parts

Complete unit	4822 691 20464 (pos. 51+61)
51	4822 492 63761
52,58	4822 520 40177
54	4822 323 50124
56	4822 520 10555
57	4822 530 80188
A	4822 390 80145

MOTOR CIRCUIT

1001	D 3	2084	G 6	3082	E 3	3086	F 4	3090	G 6	3094	F 3	6081	A 6	6082	A 7
2081	D 6	2085	G 3	3083	B 4	3087	B 4	3091	C 6	3096	D 7	6081	B 6	6083	B 7
2082	C 6	2086	G 3	3084	B 4	3088	F 5	3092	F 6	3097	E 7	6081	E 6	6084	E 7
2083	G 6	3081	B 3	3085	E 4	3089	C 6	3093	G 3	3098	G 3	6081	F 6	6085	F 7

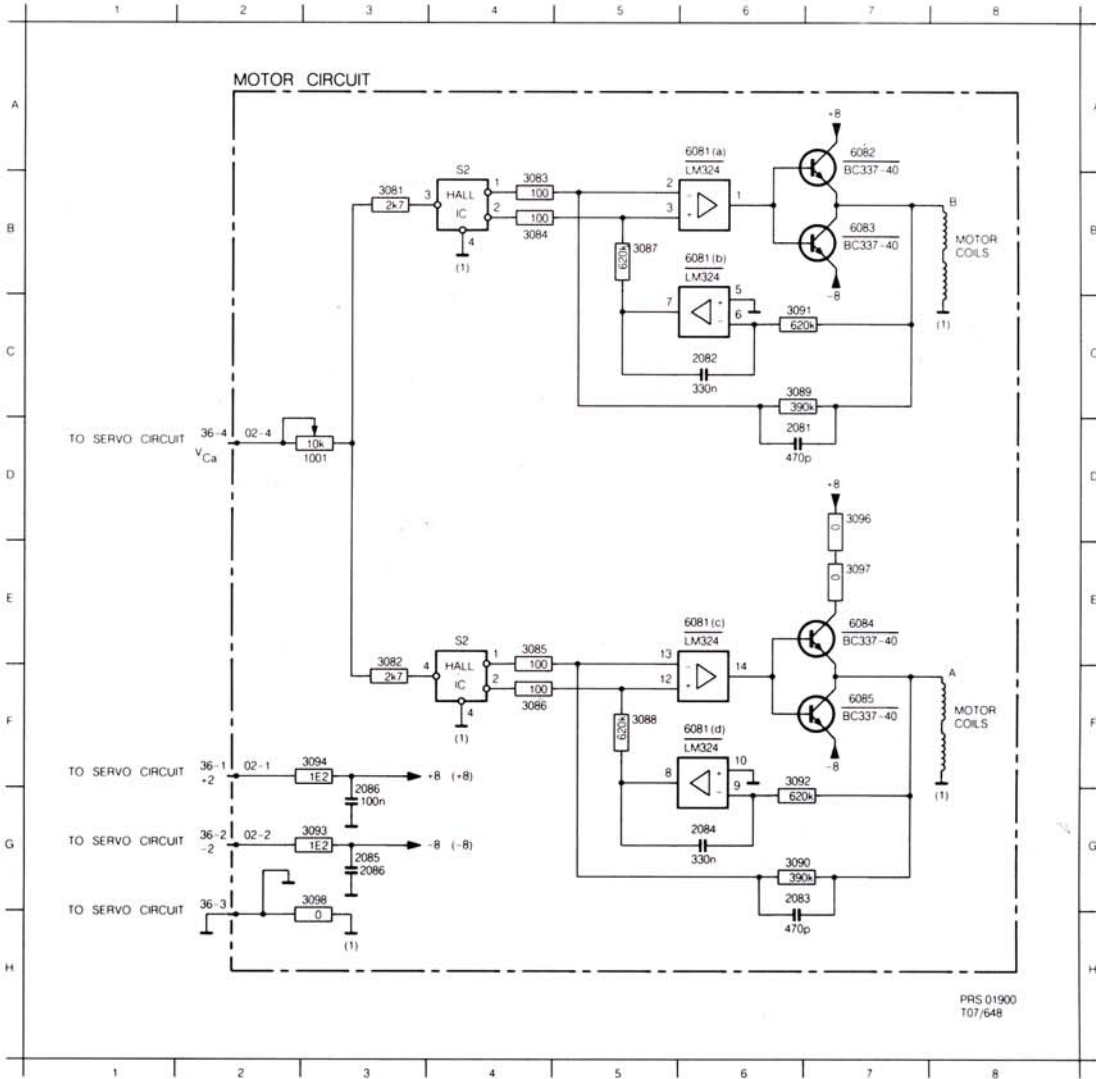

MOTOR PANEL

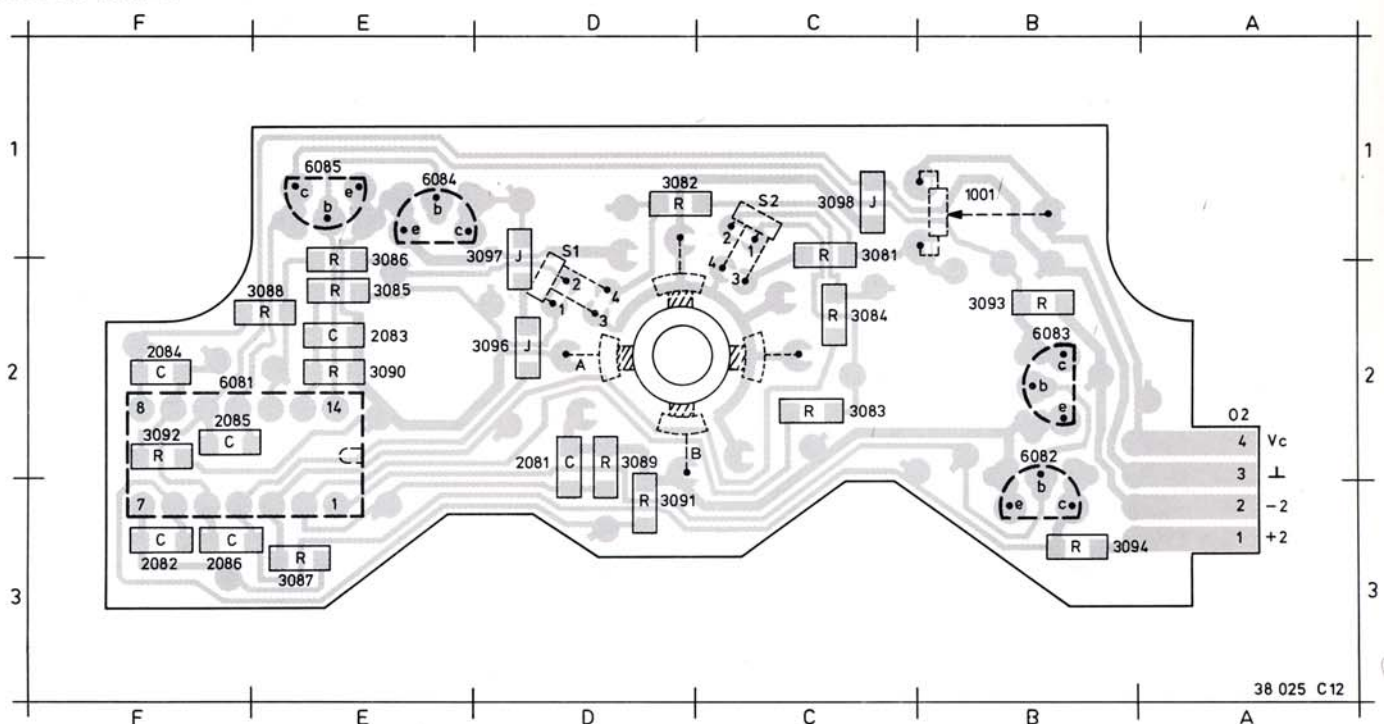

38 025 C12