

**FDK**

**INSTRUCTION MANUAL**



**MULTI-3000**

144MHz  
FM/LSB/USB/CW  
10W/1W  
PLL/SYNTHESIS/UP-DOWN  
TRANSCEIVER

Scanned by IV3AJZ

Downloaded by   
Amateur Radio Directory

**FUKUYAMA ELECTRONICS CO., LTD.**



## CONTENTS

Features of MULTI-3000 .....	1
Installation and Function.....	2
Front side Description .....	3
Rear side Description.....	5
Specifications.....	6
Precautions .....	7
Accessories .....	7
Function.....	8
Operation and Reception.....	10
Transmission .....	11
Function of Circuit .....	12
Preset Instruction .....	14
Top and Bottom Allocation.....	16
Block Diagram.....	17
Up/Dn Counter Unit/Priority Unit .....	18
Display/Driver Unit .....	19

# FEATURES OF MULTI-3000

## INTRODUCTION

Our products are all controlled in our production line however, if there is any problem on the transceiver due to mis-handling, for example, please contact your dealer.

We have reserved right to modify some part to improve this equipment without giving any prior notice to users.

## FEATURES

The transceiver model MULTI-3000 is a digital PLL base station equipment for 2 meter band equipped with dynamic UP/DOWN counter tuning system for channel selection.

The newest digital technique allows to present this multi purpose transceiver from novice to expert. UHF band transverter model MUV-430A. UHF band is applicable to this transverter as optional equipment.

### \* AC and DC power supply;

MULTI-3000 is designed as a base station transceiver yet DC power source of 12 volts is useful for mobile operation.

### \* Selector;

The switch selects position of  $\pm 1\text{MHz}$ ,  $\pm 600\text{KHz}$ , position A of repeater offset and simplex.

Position A allows to shift frequency for repeater + or - as desired within 4 MHz of range.

### \* Multi Selection System;

2 way tuning system is available but it is convenient to change frequency by synthesizer knob for FM mode and by UP/DOWN counter tuning dial for tuning in case of CW and SSB modes.

### \* 2 Steps Dynamic Up/Down Counter;

2 different frequency step system by tuning dial is prepared for FM mode with 1KHz/10KHz and for CW and SSB mode with 100Hz/1KHz respectively. This system allows very quick QSY.

### \* Easy Read-Out of frequency due to adoption of Large Size LED;

Large 7 digit LED displayer allows direct frequency read-out down to 100Hz enabling to select channel quickly.

### \* Front Panel Speaker;

The speaker installed in front panel of the transceiver provide better sound.

### \* Memory System for Quick QSY;

A push switch changes 2 pieces of CMOS IC. Memory switch and operation of tuning dial make a good combination work similar to operation of 2 VFO system.

### \* Adoption of Effective Noise Blanker;

New idea in noise blanker is effective for elimination of noise pulsation coming from mobile ignition or alternators. The noise blanker is operable at CW and SSB operation.

### \* Headphone Jack in Front Panel;

Headphone is usable.

### \* VOX Function;

VOX function switch is effective for automatic switching of TX-RX positions when operator starts talking to microphone without touching PTT switch of microphone. At the time of CW operation, it will be in the condition of semi-break in.

### \* 2 Meter System;

2 meters are adopted in the transceiver, one of which is for indication of Signal/Power and another one is center meter for FM mode operation.

Signal/Power meter acts as S-meter in case of reception and as output power meter in case of transmission. Set needle of the meter to center position for FM mode through control of RIT knob or adjustment of the tuning dial which results tune into signal coming from the other station.

## INSTALLATION AND FUNCTION

### \* 2 Step Output Power (Hi/Low);

A toggle switch can change RF output power of 1W and 10W. Emission of 1W output is enough to local QSO.

### \* Protection Circuit in Final Stage Transistor (APC);

Protection circuit prevents damage of final transistors when over current is induced there incidently, for instance, owing to extraordinary affair happened in antenna circuit.

Mis-Matching, short circuit of antenna and power transmission without connection antenna, etc, do not give serious affection to the final transistors.

### \* Balanced Mixer;

In order to eliminate spurious radiation adequately, FET(3SK40) balanced mixer is adopted in Heterodyne circuit.

### \* RF Gain Circuit;

A toggle switch select one of 2 position of RF gain for DX (Long range) and LO (local). The selection is required some time in order to get proper channel rejection and will suppress ineffective input signal. The equipment can reproduce clear signal owing to control of the RF gain knob accordingly.

### \* Unitary Modules;

Each module has function independently and composing PLL unit, Up/Down counter unit, TX and RX units, etc. The transceiver is consisting of 20 modules in total to keep good facility in regard to maintenance and production efficiency.

## INSTALLATION

### 1. Power Source:

It is not necessary to prepare special DC power supply unit like mobile transceiver do. AC power source is available in your house.

### 2. Antenna Installation:

G.P and Yagi antenna are popular. Make conditioning for matching by using SWR meter to get figure less than 1.5. If your condition do not allow to limit extension of coaxial cable less than 15 meter, We recommend you to apply high performance cable such as RG-8/U. In case of showing high SWR figure, it will be troublesome for antenna to absorb RF power and antenna protection circuit may break contact of relay for transmission.

When you install Yagi antenna on the roof, antenna support will help you for easy working. Take care of wiring of coaxial cable with antenna terminals and cover the connecting parts in water proof with vynil tape.

It is recommendable to erect triangle tower or pipe mast for antenna system (12 — 25M high). They will be found in your ham shops. Characteristics of G.P antenna is indirect and covering area is limited for QSO in distance accordingly and signal selectivity is in perfect.

Yagi antenna has function to pick up signal and emits power in a limited direction efficiently, thus requiring rotation of the antenna around the tower.

The most recommendable antenna system is therefore to apply both G.P. and YAGI antennas and to switch them according to your purpose, G.P. for watching the stations in reception and YAGI of multi-elements for DX QSO.



■ **Phone jack**  
For apply headphone (Mono-type)

■ **Mic gain control and vox switch**  
Microphone input sensitivity control at clockwise increase and VOX (Voice Control Operation) function operates, when pull this knob.

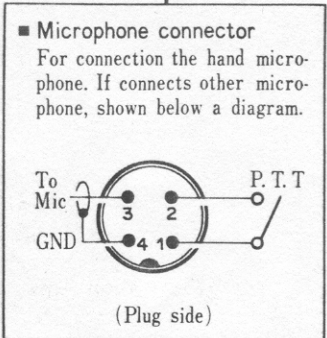

■ **S/RF meter**  
Indicates incoming signal strength during receive and when transmission, reads approx. 7-8 position depends 10W output power in FM and CW mode.

■ **Center meter**  
(Not operate SSB, CW mode)  
Indicates FM receiving frequency discrimination. Turn the RIT knob until the needle becomes at the center.

■ **RF GAIN knob**  
For receiving RF

■ **PULL TONE B ON/OFF Switch**  
The unit delivers carrier by tone pushing PTT switch transmission.

■ **Synthesizer sel**  
MHz selected 144 MHz each steps VFO tuning knob. 100KHz selector 100KHz steps, 10 switch each 10KH On/Off touch sw under the SYNTH

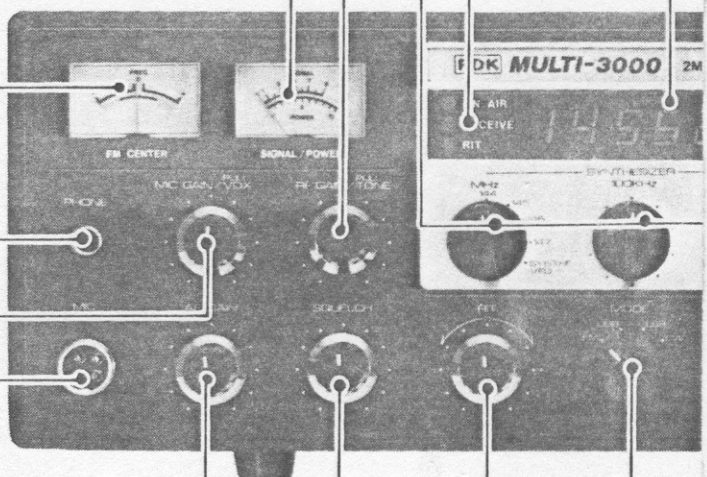

■ **AF GAIN knob**  
Audio control knob. Turning it clockwise increases audio level.

■ **SQUELCH knob**  
Turning the knob clockwise switches squelch on to cancel noise when no signals are received. Employed our unique AFB squelch circuit.

■ **RIT tuning knob**  
When turn on the RIT control move KHz without any transmit frequency at adjuster section.

■ **MODE Selector**  
Desired operation this knob for FM or CW position.

Scanned by IV3AJZ □  
Downloaded by □  
Amateur Radio Directory



knob  
g RF gain control.  
NE Burst  
Switch  
ivers tone burst to  
tone switch-on and  
switch for trans-

er selector knobs  
d 144/145/146/147  
steps or SYNTHE.  
knob.  
ector switch each  
s, 10KHz selector  
10KHz steps, 5KHz  
h switch (located  
YNTHE. VFO knob).

■ Led function indicator and digital frequency displayer  
○ ON AIR -  
During transmission indicates.  
○ RECEIVE -  
During reception indicates.  
○ RIT -  
Under the speaker RIT switched on, receiving incremental tuning operates indication.

■ Seven digital frequency displayer indication  
Desired at 144/145/146/147 MHz synthesizer knob and 5KHz step change at the any mode position. In the "MHz" position change to "SYNTHE. VFO" tuning dial.  
FM mode  
Normal each 1KHz  
Fast each 10KHz  
SSB/CW mode  
Normal each 100Hz  
Fast each 1KHz

■ MEMO button  
This memo switch operates at SYNTHE. VFO position, memo write and erase are both instant recall type. Memorized frequency approx. 20 - 30 min after OFF the power.

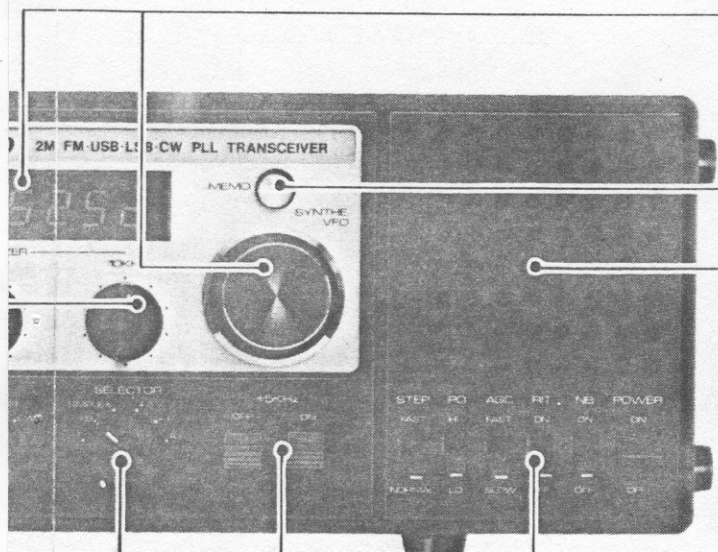

Speaker

knob  
n the RIT switch,  
move approx. ±3.5  
any adjust the  
quency. See detail  
adjust the recei-

■ OFFSET Selector switch  
For selects PLUS or MINUS offset frequency at FM mode operation, normally set at the SIMPLEX position if other mode.

■ Function switches  
STEP :  
Each 100Hz step at NORMAL position on the SSB and CW mode, 1KHz at FM mode operation. Each 1KHz step at FAST position on the SSB and CW mode and 10KHz at FM mode operation.  
P.O :  
An RF output power selected 10W at HIGH, 1W at LOW position of the any mode.  
AGC :  
Can selectable Automatic Gain Control FAST or SLOW position on the SSB and CW mode.  
RIT :  
For a fine tuning of receiving frequency independent of transmitting frequency. (See also RIT tuning knob).  
NB :  
Used for cancelling pulse noises, such as ignition noise, for noise-free communication (Operates are SSB & CW only).  
POWER :  
Supplying power ON/OFF switch. (Both AC and DC)

ector switch  
ation mode selects  
r FM, USB, LSB  
on.

■ +5KHz ON/OFF switch  
Function operates at synthesizer operation only, one shot ON or OFF button.



## PRECAUTIONS

The MULTI-3000 is designed for safe operation, but be sure to observe the following instructions for trouble free, enjoyable operation.

- \* Do not transmit without connecting an antenna.
- \* Be very careful about the power supply polarities. Do not mistake the AC cord for the DC cord or vice versa.
- \* Do not connect or disconnect the power cord when the power switch is in the ON position.
- \* Use the 5A fuse in the fuse holder on the DC cord when operating on DC; or the 2A fuse in the fuse holder in the rear when operating on AC.
- \* The MULTI-3000 possible to transmission for a long time, but it is suggested that continuous transmission not longer than 30 minutes be avoided as much as possible.

- \* All the cores and trimmers inside have already been adjusted, and therefore should not require adjustment.
- \* If the synthesizer cannot be locked, turn the power switch OFF, wait for 4 to 5 seconds, and then turn it ON again.
- \* Make sure that the SELECTOR switch and the MODE selector switch are in the correct positions. Also check the RIT knob and see that they are also in the correct positions.

## ACCESSORIES

The MULTI-3000 has the following accessories. Please check that you have all of them.

Instruction manual.....	1
AC power cord (with connector).....	1
DC power cord (with connector and fuse).....	1
Key plug .....	1
Spare fuse (AC 2A, DC 5A).....	1 each
Dynamic microphone (with connector).....	1
9P accessory plug .....	1
3P fan plug .....	1
Headphone plug .....	1
EXT SP plug .....	1



## FUNCTION

### \* POWER;

Power switch is in position Up/ON and Down/OFF. Do not make power switch on and off during transmission as the life time of the switch will be shoten.

### \* AF GAIN;

Knob rotation to clockwise direction increase audio sound. Set it at suitable position.

### \* SQUELCH;

At the time of waiting input signals, there have noise in a certain extent. Rotate the knob of squelch control clockwise slowly and then the noise will be suppressed adequately.

Stop rotation there and you will hear voice without noise only when the equipment receive input signals. When intensity of the input signal is in low level or not enough to catch it adjust position of the knob again.

### \* MIC GAIN;

When turning the knob clockwise, microphone increases gain and when you talk to the microphone far from it, adjust the gain.

### \* RF GAIN/Pull TONE;

RF GAIN is to control RF amplifier as explained previously and tone burst/tone squelch is effective when pulling the knob. (optional purpose).

Tone burst frequency is 1,750Hz in the European version and tone squelch unit is for the USA version.

### \* RIT;

RIT knob is to compensate frequency drift of input signals.

Clockwise rotation increases chasing frequency and the counter-clockwise reduces it within variable range of  $\pm 3.5\text{KHz}$ .

### \* MODE;

4 modes are available, namely FM, USB, LSB and CW.

### \* SELECTOR;

This is selector of repeater offset positions, They are  $-1\text{MHz}$ ,  $-600\text{KHz}$ , SIMPLEX,  $+600\text{KHz}$ ,  $+1\text{MHz}$  and position A according to direction of rotation. Refer page 15 of this manual regarding the position A and how to set desired frequency for special offset. Selective range of the position A is limited in  $\pm 4\text{MHz}$ .

### \* SYNTHESIZER;

There are 3 knobs to change frequency of synthesizer for FM operation. They are functioned to change frequency in the order of MHz, 100KHz and 10KHz. In addition, 5KHz shift is available by 5KHz ON/OFF switch.

### \* SYNTHE. VFO;

This is Up/Down counter dial ready for operational facility at SSB and CW operation. Clockwise rotation of the dial shifts frequency upward and the counter-clockwise shifts it downward.

Shift range of frequency is from 144.000MHz to 147.999.9MHz and the shift is stopped at the edges of the band automatically.

### \* MEMO;

MEMO push-switch is useful to memorize special frequencies by it's ON-OFF action. The switch is effective when you operate with SYNTHE VFO dial. The following is one of example of FM mode operation.

- 1) Set digital frequency at 145.000MHz by synthe VFO dial and memorize it as calling frequency.
- 2) You find out a station at 145.000MHz to start QSO and intend to find other channel not yet occupied. Then you find it at 145.260MHz.
- 3) Push Memo switch to memorize 145.260MHz. The displayer shows 145.000MHz recorded previously and then you can call QSY at 145.260MHz for the station now you are in contact. Push the switch again to realize 145.260MHz in the displayer and start QSO.



## FUNCTION

The above fact means it is quite same with that there are 2 VFO systems selective each other. Memory of frequency is alive for 10 – 30 minutes approximately after cutting out power supply. If you set 4 Ni-Cads batteries NR-N or the equivalent in series on the battery box shown above, It is quite possible to keep memory of the selected frequency for a long time.

Frequency synthesizer selector is set at 145.200MHz and push MEMO switch and then this frequency has been memorized.

### \* PO;

This is switch to change output power. HI emits 10W and LO emits 1W.

### \* AGC;

AGC time constant require 2 position. SLOW for SSB and FAST for CW. Response of S-meter indication is quick at FAST and SLOW position.

### \* RIT;

When you control RIT knob, turn it on and you will see red LED illuminate.

### \* STEP;

Frequency steps by SNTHE VFO dial are fixed at 10KHz step/FAST and 1KHz step/NORMAL at FM mode. 1KHz/FAST and 100Hz/NORMAL for SSB and CW modes. At the time of FM operation, NORMAL step realizes 1KHz shift and if you change the switch to position FAST after you set figure in the order of 10KHz.

### \* 5KHz STEP;

In addition to the above, there are 2 button-switches to shift frequency every 5KHz. On-switching realizes 5KHz and the OFF cancel.

### \* NB;

This is noise blanker to kill harmful pulses like ignition noise it works at SSB and CW modes only.

### \* Conditioning of SYNTH. VFO dial brake;

You will find a screw for adjusting sliding brake of the dial inside of bottom cover of the transceiver. This controls rotation speed of SYNTH. VFO dial shown below.

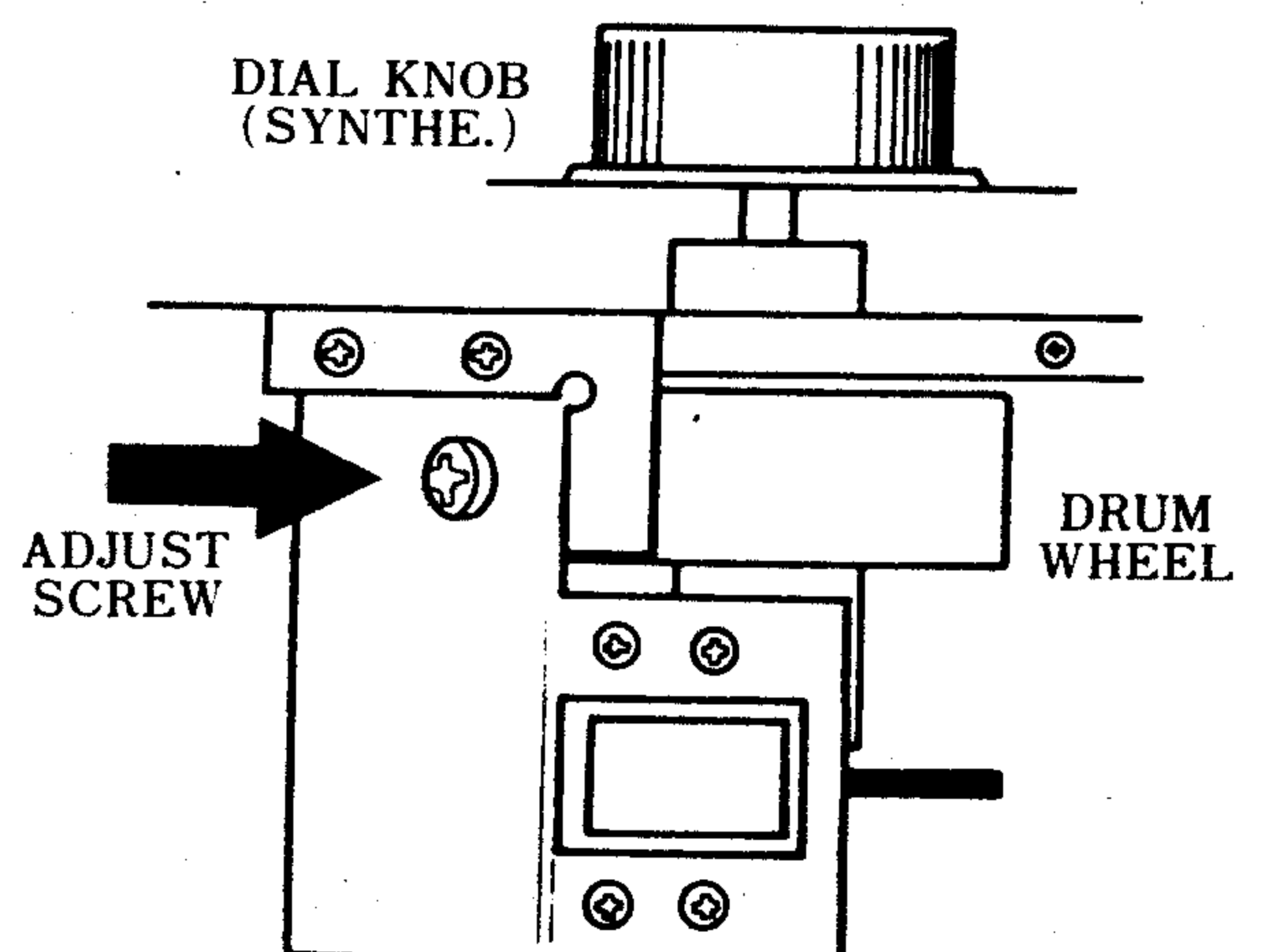
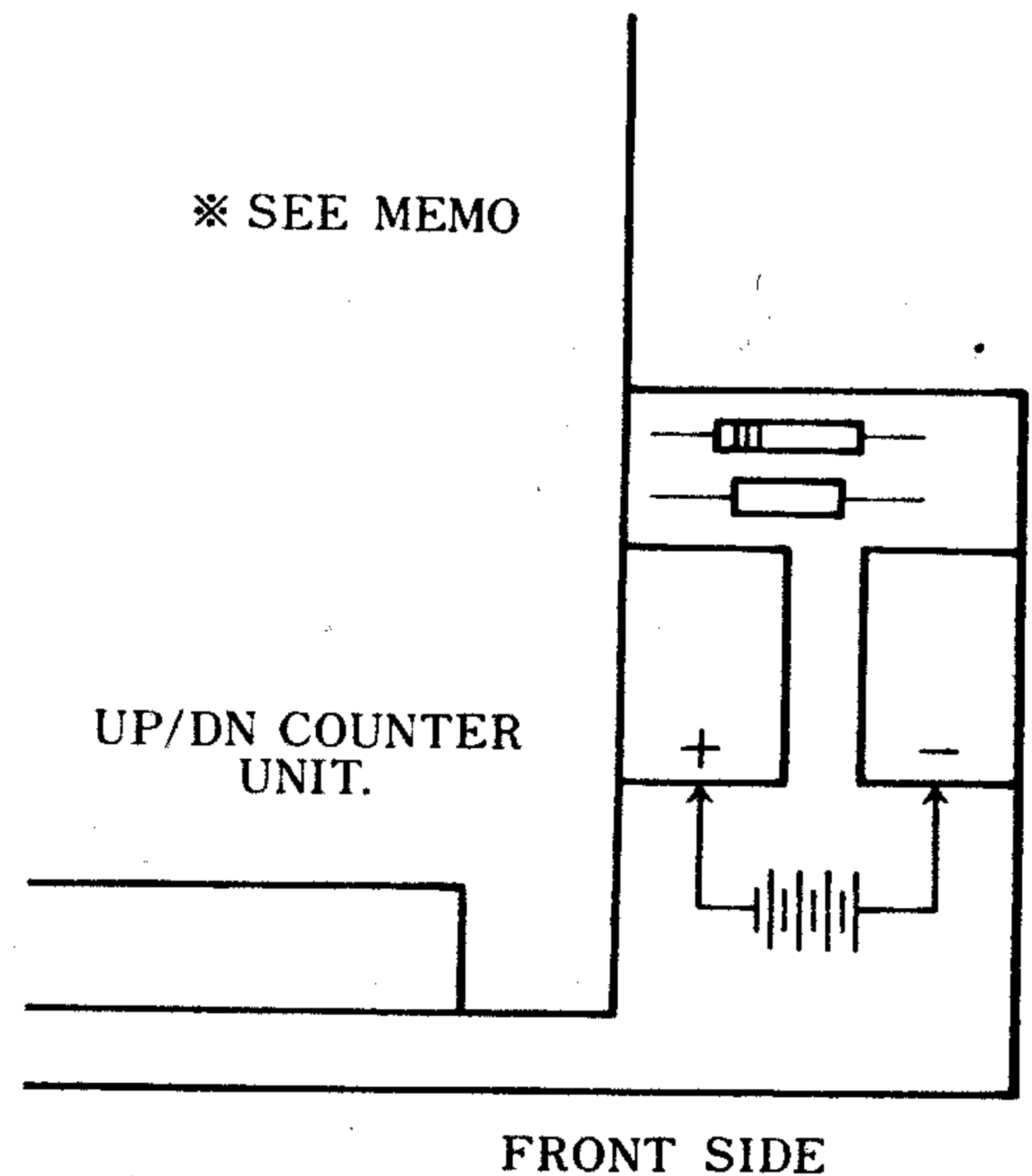



# OPERATION AND RECEPTION

- \* Terminate antenna to antenna connector at the rear panel. Connect accessory AC cord to terminal plug for power supply.
- \* Turn power switch on to start operation.

## Connections on the Rear panel

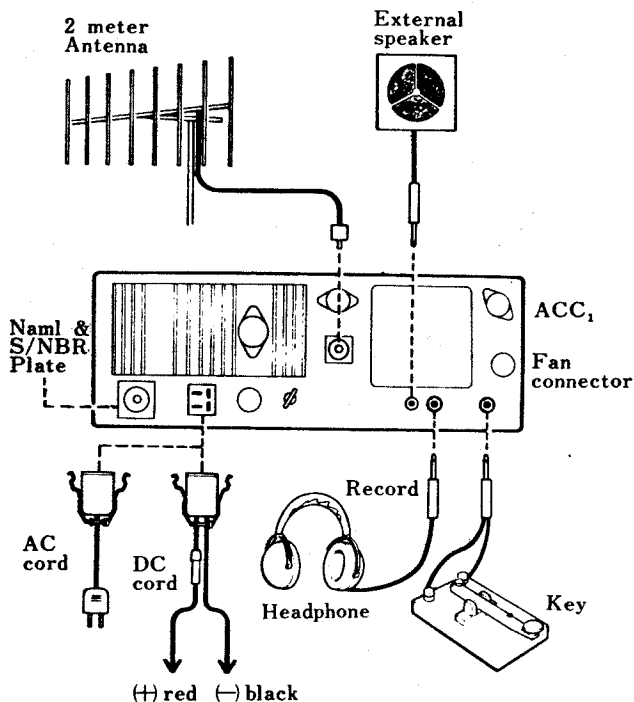

When you make shift of frequency by NORMAL-1KHz step at first for setting frequency in 1KHz every step and then put the switch position to FAST for 10KHz step, frequency reads every 10KHz.

If the step is set at NORMAL in even number at first in the order of 10KHz, frequency varies every 10KHz in even in the order of 10KHz after setting position of STEP switch at FAST.

## Center meter indication vs receiving tuning point

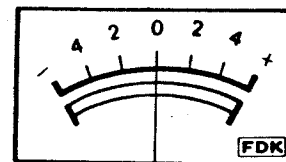

Correctly tuned

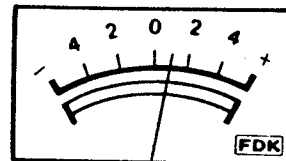

Other station's transmitting frequency higher

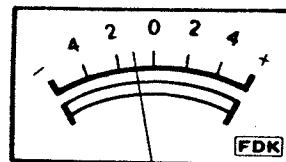

Other station's transmitting frequency lower

## RECEPTION

### 1. FM mode;

Set the knob of selector at FM mode.

Turn squelch knob fully clockwise at first. Noise will be heard at the time not receiving input signal and then find the position where the noise is cancelled.

Set AF GAIN knob at suitable position.

For FM operation, it is convenient to change frequency by SYNTHESIZER knobs usually. It covers 800 channels including 5KHz step.

In case of changing frequency very often in succession, set the knob of MHz for SYNTHESIZER at the position of SYNTHE VFO so as to shift frequency by the dial.

Choice position of STEP switch to shift frequency as you need during controlling the dial, namely NORMAL-1KHz step and FAST-10KHz step.

### 2. SSB mode;

Set position of MODE selector at USB (USB is accustomed in 2M band operation).

Adjust AF GAIN knob. No function of squelch at SSB mode.

For SSB operation, make in use of SYNTHE VFO dial to shift frequency. Select SYNTHE VFO position. FAST position of STEP switch is for 1KHz step and the NORMAL is for 100Hz step. When you want to shift frequency quickly or to find channel not yet occupied, it is better to slide the dial with FAST position at first and then to tune with NORMAL position precisely.

In order to tune in frequency of input signal, look for point Zero-in where the reproduced voice will be most clear. When starting tuning in the input signal from lower frequency, it begins to reproduce



## RECEPTION AND TRANSMISSION

treble sound and you will find position to make clear sound.

This is the point Zero-in for the best tuning. If you turn the dial more to same direction, reproduced voice will be changing like a distorted sound in low range.

When input signal frequency hard to tune in, turn RIT knob on and chase to find the point Zero-in.

If there are pulse noise incoming from ignitor etc, make NB switch on. The noise will be suppressed and it will be possible to clarify input signals in the lowest level.

In case that the input signal is too strong and makes distortion on sound reproduction, reduce gain by adjusting RF GAIN knob.

### 3. CW mode ;

Operation of CW is done in just same manner with SSB operation excepting MODE selector position.

## TRANSMISSION

### 1. FM mode ;

Select FM position of MODE switch.

Set frequency of transmission.

Push microphone PTT switch to emit power.

The meter is now RF meter to indicate output power and it shows some points between 7 and 9 at 10W output power.

If indication of the meter is extremely in low level, there will be some trouble in antenna system.

Adjust modulation with MIC GAIN control. Turn the knob fully clockwise in FM operation and position of 12 o'clock will be the best for SSB operation.

Save output power and switch to 1W output at the time of local QSO.

### 2. SSB mode ;

Set selector position to USB.

Turn MHz knob of SYNTHESIZER to SYNTH. VFO. Frequency step should be done at NORMAL of 100Hz at first. You will be able to change frequency steps properly after several time of practice.

It is necessary to turn MIC GAIN knob to the position of 12 O'clock. Full turn of the knob will be cause of distortion in modulation.

Select disired frequency by the dial and take note about channel frequencies in the band.

RF meter does not indicate anything during transmission without modulation. The meter swing only when the carrier is modulated and intensity of the swing of needle is proportional to loudness of voice accordingly.

No meter indication at SSB operation without modulation of the carrier but in FM operation the meter indicates around number of 7-9 always during transmission.

Once starting QSO, do not touch the tuning dial. Chase the input signal by RIT knob when it begin to drift and try to find out the point Zero-in once more.

Utilization of VOX system will bring you comfortable operation for long time QSO.

### 3. CW mode ;

Select position of MODE selector to CW.

Connect key trough jack on rear panel.

Make VOX switch on. The Transceiver is ready for semibreak-in operation.

Key operation transmit CW signal immediately. If the operator stop key operation, the transceiver become in the state of reception automatically after a certain delay time.

If it is not necessary to make semi-break-in state, terminate a switch between pin No.4 and No.9 of accessory Socket at rear panel for sending CW signal. This switch should be made on before starting key operation, otherwise push PTT switch of microphone before key operation.



# FUNCTION OF CIRCUIT

## \* PLL Unit;

This consists of units L-1, 2, 3, 4, 5, 6, 7, 22, 24 etc. The following is block diagram of PLL section. I-1 is FF unit containing IC oscillator of 10,000MHz and 3 stages of IC divider to distribute 10KHz eventually. I-2 is programmable divider 1/N unit. 3 IC cover full range of frequencies of the transceiver. 1/N shows 1/300 for 144.000MHz and 1/400 for 145.000MHz.

## \* PD-VCO Unit;

I-3 is PD-VCO unit containing voltage control oscillator.

The output frequency is decided according to 2 factors. One is phase comparator (P.D) DC output functioned by difference of a standard signal and the output of 1/N unit and the another is the voltage of P.D through variable capacitance diode.

The output of I-3 becomes local oscillator signal after passing through Buffer unit I-7. The frequency of the output is of 127.1MHz for 144.00MHz and of 128.1MHz for 145.00MHz.

## \* VCO MIX Unit;

VCO MIX unit is I-6. The function is to supply to mixer multiplied 22.000MHz from 11.000MHz of X'tal oscillator. A signal 102.100MHz multiplied 9 times from 11.344MHz oscillated in VCO PD unit of I-5 and the above 22.000MHz are converted to 124.100 MHz in the mixer.

The signal of 124.100MHz is mixed with the output of VCO and converted to signals between 2 and 7 MHz, which are sent to 1/N unit passing through low pass filter.

PLL DIAGRAM

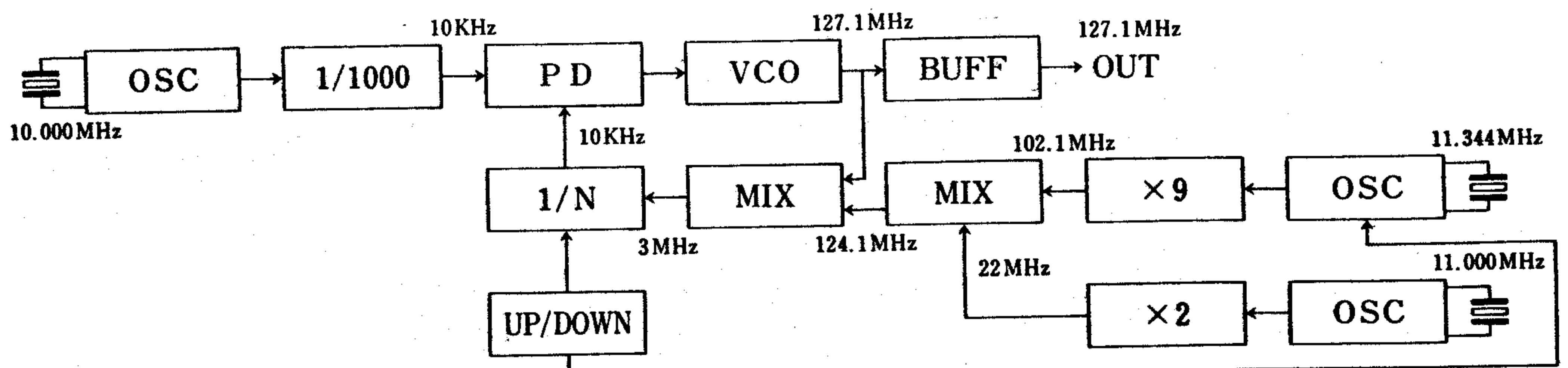



## FUNCTION OF CIRCUIT

### \* UP/DOWN counter ;

Up/Down counter unit I-22 is consisting of Up/Down counter 2 memory modules of D latch, data selector to select one of 2 memory modules, a part of control circuit, DA converter and controller.

Up/Down counter counts and memorizes number of pulses of clock generator and fixed frequencies by sending pulses to 1/N unit and frequency displayer through data selector.

D latch memorizes content of Up/Down counter at the time of pushing off the MEMO switch. In addition, the content in the D latch memory is also memorized in the Up/Down counter. The content of the both unit is exchanged.

D/A circuit provide the output, which controls oscillating frequency ( $44 \times 9 = 102.1\text{MHz}$ ) of VCO LO unit.

Steps of frequency at SSB mode is 100Hz or 1KHz below 10KHz and also 1KHz step at FM mode. For variation of the frequency more than 10KHz, it is necessary to vary 1/N of PLL circuit.

Data selector circuit and controller are specialized to control these circuits.

Another function for setting free offset frequency is included in this unit.

### \* CLOCK Unit ;

1 rotation of Up/Down counter tuning dial provide 50 pulses with combination of LED and photo-transistors and the pulses are sent to Up/Down counter.

### \* FM Local Unit (I-8) ;

The unit contains X'tal oscillator of 16.900MHz necessary for FM transmission and tuning circuit for TX converter.

### \* TX CONVERTER Unit ;

2 dual gate MOS-FET in balanced mixer converts IF signal of 16.900MHz and the output of VCO to 144MHz signal. Furthermore, a part of tuning is done by variable capacitance diode and digital signal delivered from PRIORITY unit every 1MHz is effective for automatic tuning.

### \* BOOSTER Unit (I-10) ;

This is power amplifier of 10W output. 2 stages of transistors are mounted on a heat sink having adequate heat capacity. APC circuit and voltage control transistors for power switching are also applied on that.

### \* RX Unit (I-11) ;

RX SSB signal passes through RF amplifier, helical resonator, heterodyne mixer, X'tal filter and reaches to SSB IF unit of 16.9MHz. FM signal passes X'tal filter, narrow band ceramic filter of 455KHz and is detected through limiter for AF amplifier.

2 stages of noise amplifier and 1 stage of AFB amplifier for squelch present unique and smooth squelch operation. Noise blanker is prepared for SSB mode to suppress various noise pulsations such as ignition noise, thus resulting to clarify input signal in the critical condition for reception.

### \* SSB IF Unit (I-12) ;

Fundamental circuits for SSB reception are installed in the unit. They are TX-ring modulator, RX-ring detector, AGC circuit, IF stage, AF amplifier and S meter auxiliary circuit.

During SSB operation, the unit generate DSB which becomes SSB signal through high performance 6 elements of X'tal filter. CW carrier is created by unbalanced DC position in ring modulator.

### \* SSB LOCAL Unit (I-13a) ;

In SSB transmission, this unit acts as carrier generator and as BFO unit of ring detector at SSB reception. Oscillator has 2 X'tals and diodes to select USB, LSB and CW mode respectively.

The frequencies are as follows :

USB .....	16.8985MHz
CSB .....	16.9015MHz
C W .....	16.8985MHz

### \* AF Unit (I-16) ;

AF stage adopts powerful IC. CW monitor circuit, CW keying and protection circuit of final RF stage (APC) are installed in the unit.

## PRESET INSTRUCTION

### \* MIC AMP Unit (I-17);

This is AF microphone amplifier for FM and SSB operation. composition is preamplifier for both SSB and FM operation.

The signal for FM mode is passing through IC AF amplifier, automatic frequency deviation limiter, spratter filter, integral amplifier and modulated directly with variable capacitance diodes in VCO unit. In SSB operation, the signal is delivered to SSB IF unit through AF amplifier and spratter filter. CW Semi-break-in circuit and meter auxiliary circuit are also mounted in this unit.

### \* AVR Unit (I-14);

Power source for the transceiver is AC or DC. Bridged rectifier mounted on heat sink having adequate heat capacity, voltage controlling transistor, 3 terminals voltage regulator, power transformer and their auxiliary circuits collaborate, to supply stabilized DC voltage of 13.8, 8, 5, 7, 6 and 5 volts respectively.

### \* DISPLAY and DISP-DRIVE Units;

Display unit (I-20) and display-drive unit (I-21) consists LED and their drivers. Numerical displayer is 7 digit including 100Hz display section. There are indicators of TX and RIT in reception.

### \* VOX Unit;

IC-1 amplifies microphone input signal, which is detected by D3-4 and sent it to IC-2 for establishing a certain delay time.

TRI-2, VR-1, VR2 and VR3 is composing anti-trip circuit, volume controls of VOX GAIN, ANTI-TRIP and DELAY respectively.

### \* RECORDER Unit;

The unit provides audio output to REC terminal with low impedance.

### \* How to use VOX;

When the VOX switch is turned ON, transmission and receiving standby will be automatically changed

over by sound without depressing the PTT switch on the microphone. VOX sensitivity can be adjusted by three holes at the bottom side and turning the VOX GAIN knob. Then, in receiving condition, operate VOX and adjust the ANTI-TRIP knob so VOX will not be erratically driven by sounds from the speaker.

If the ANTI-TRIP knob is turned clockwise excessively, the VOX circuit may be driven by noise, etc., making it impossible for you to proceed to transmission. Exercise care when adjusting this knob. Return time to reception can be adjusted with the DELAY knob.

— Pull-out of MIC GAIN knob makes VOX switch on. Adjust VOX sensitivity by VOX GAIN volume. Be very careful so as not to operate the transceiver by reproduced voice of loud speaker. The adjustment of sensitivity is done by ANTI-TRIP volume installed at the bottom of the transceiver.

— DELAY volume to adjust reset tuning between RX and TX and VOX gain volume are also located there. Take care not to raise sensitivity of VOX so high. Otherwise simple noise is a cause of transmission and the transceiver will not work in reception at all in this case.

VOX GAIN, ANTI-TRIP and DELAY volumes are conditioned in the factory before delivery.

### \* How to set position A for Free offset;

For setting desired repeater offset, set position of SELECTOR at the position A. This position A is also useful to apply transverter model MUV-430A for UHF band operation.

Set the offset frequencies according to the following procedure.

1. Connects 2 places marked in top view of printed circuit board I-41 by resistors 100K ohm.
2. Programmable A offset on this board and terminate necessary positions by diodes 1S-1555 and 1N-60 by means of soldering as shown in the following pattern.







# TOP AND BOTTOM ALLOCATION

## TOP VIEW

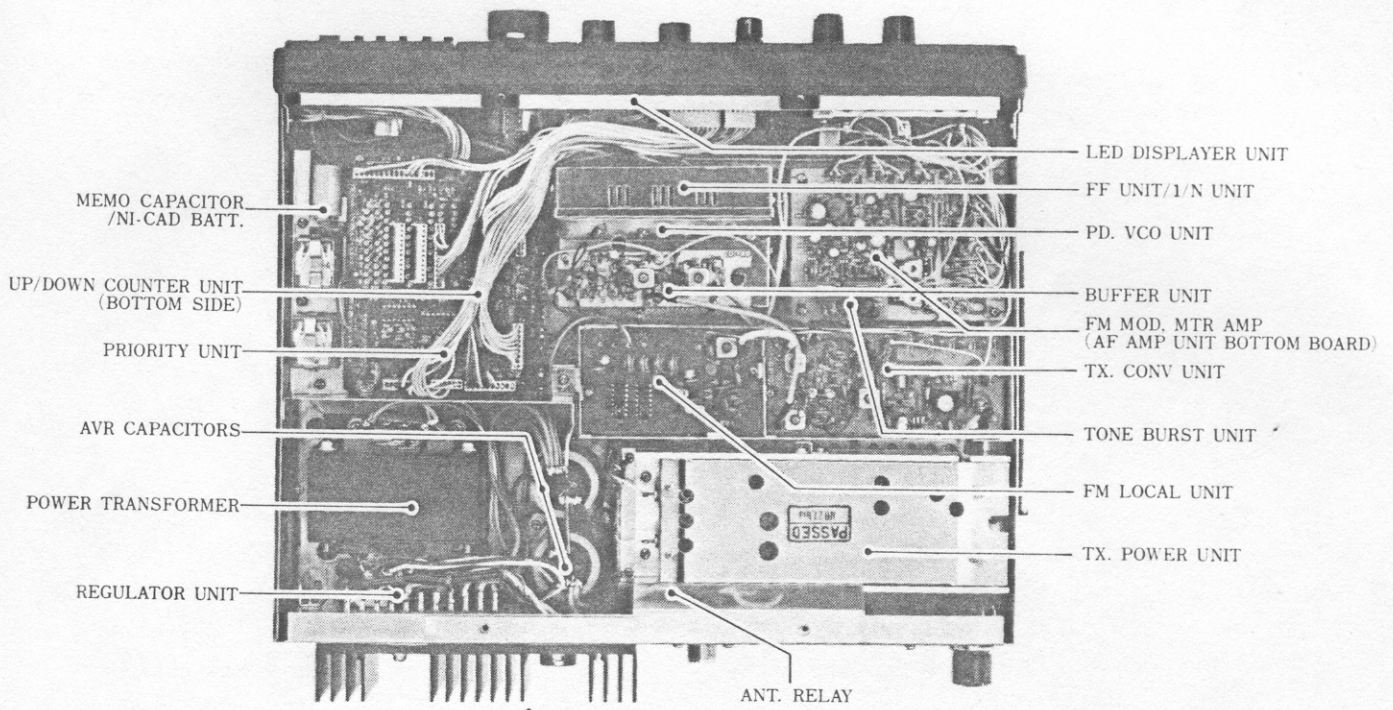

Scanned by IV3AJZ



Downloaded by  
Amateur Radio Directory

## BOTTOM VIEW

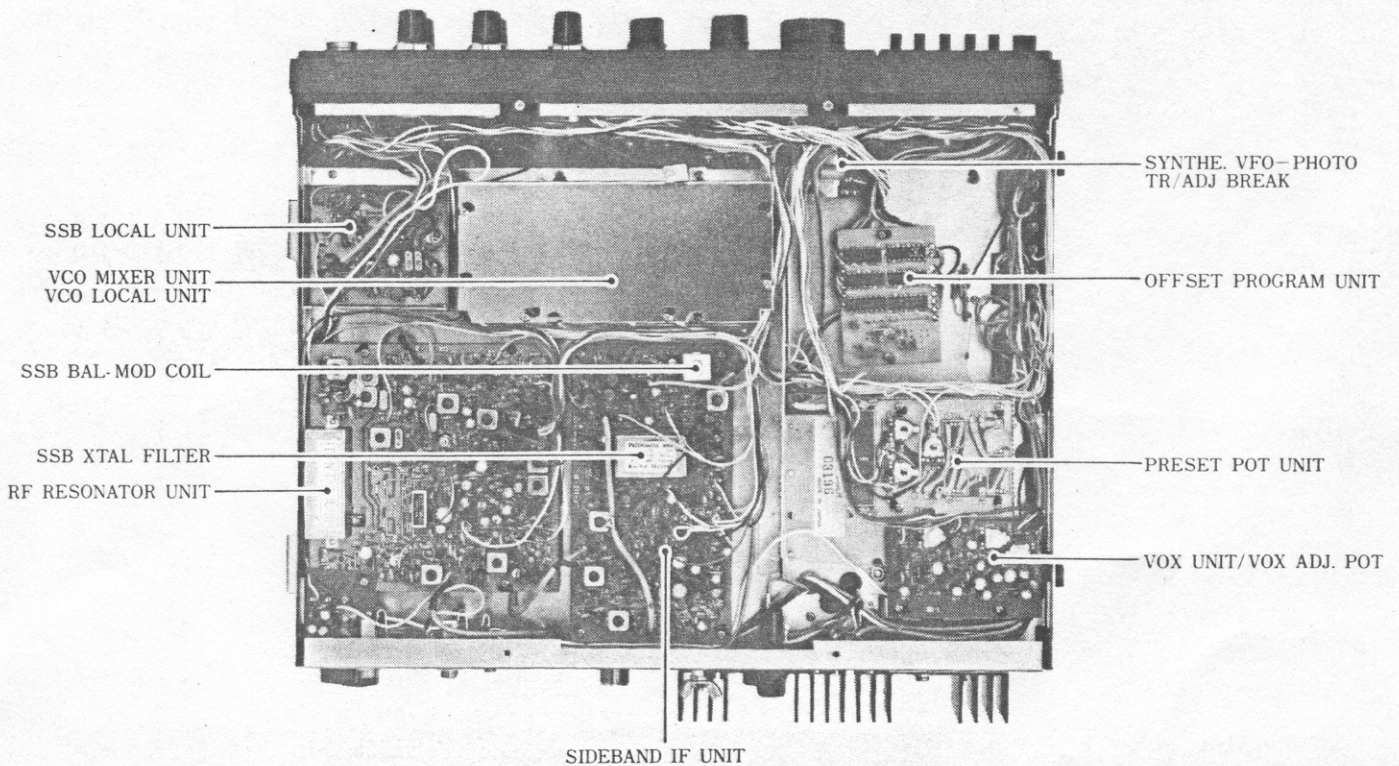



# BLOCK DIAGRAM

Scanned by IV3AJZ  
 Downloaded by  
 Amateur Radio Directory

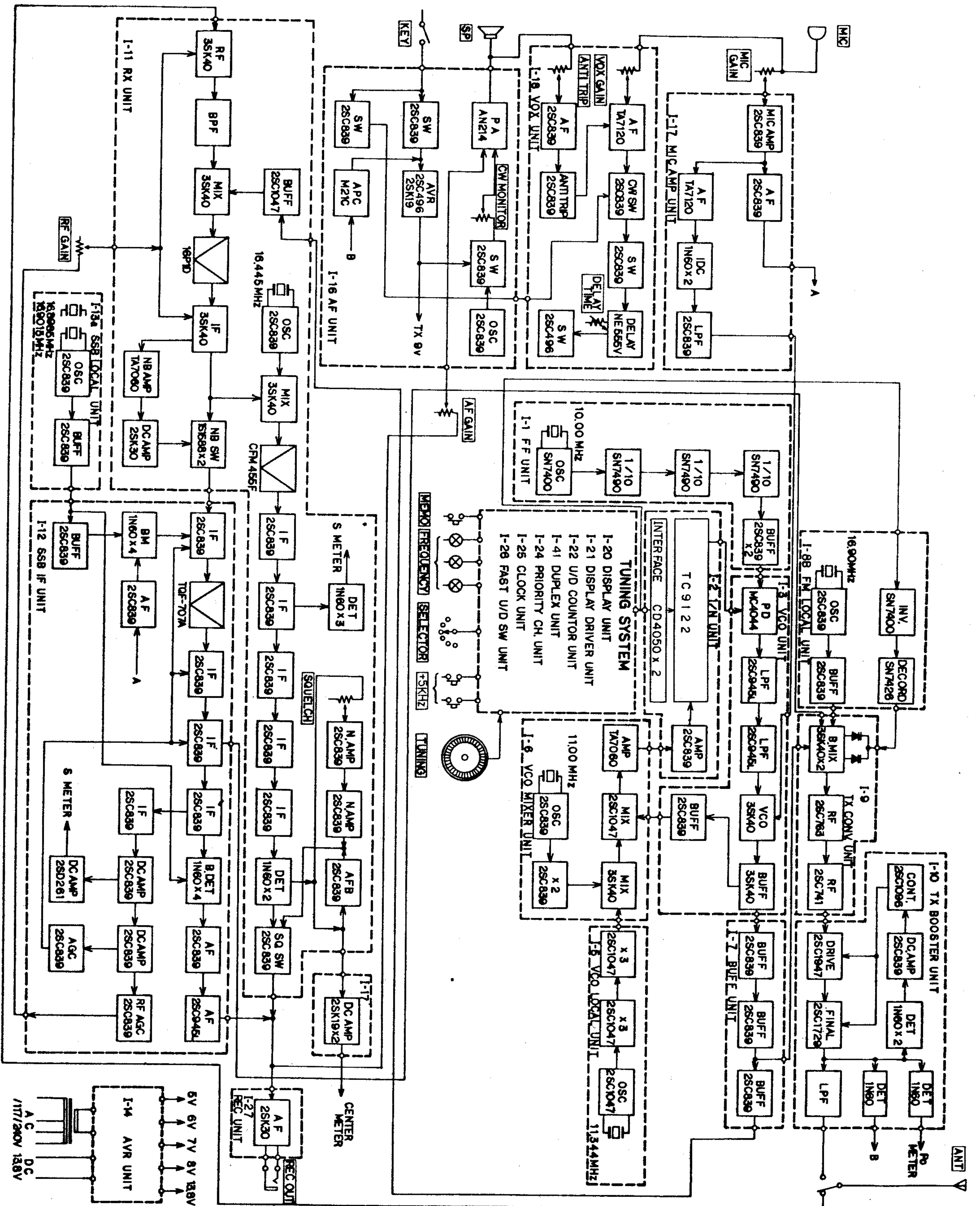

# UP/DN COUNTER UNIT / PRIORITY UNIT

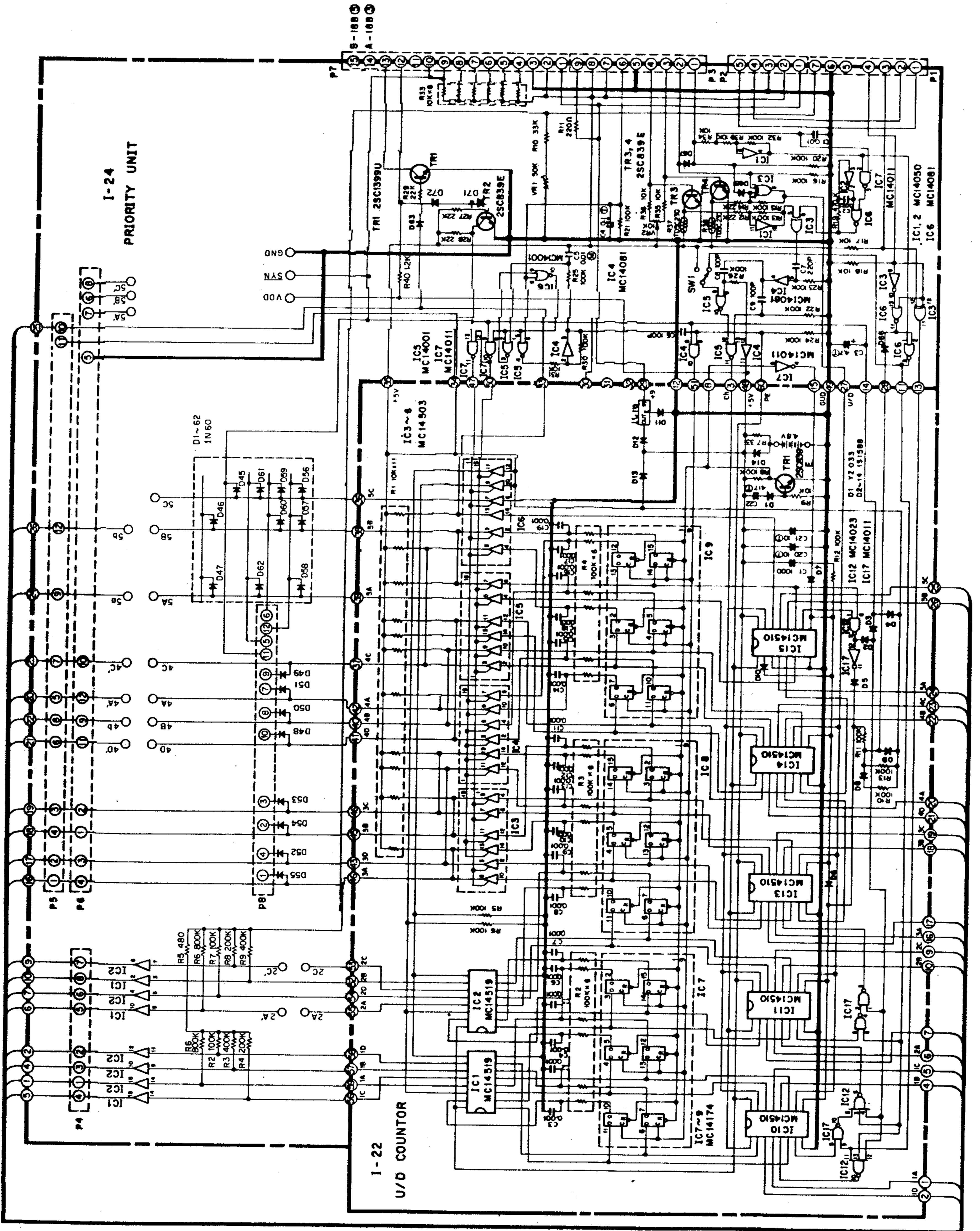



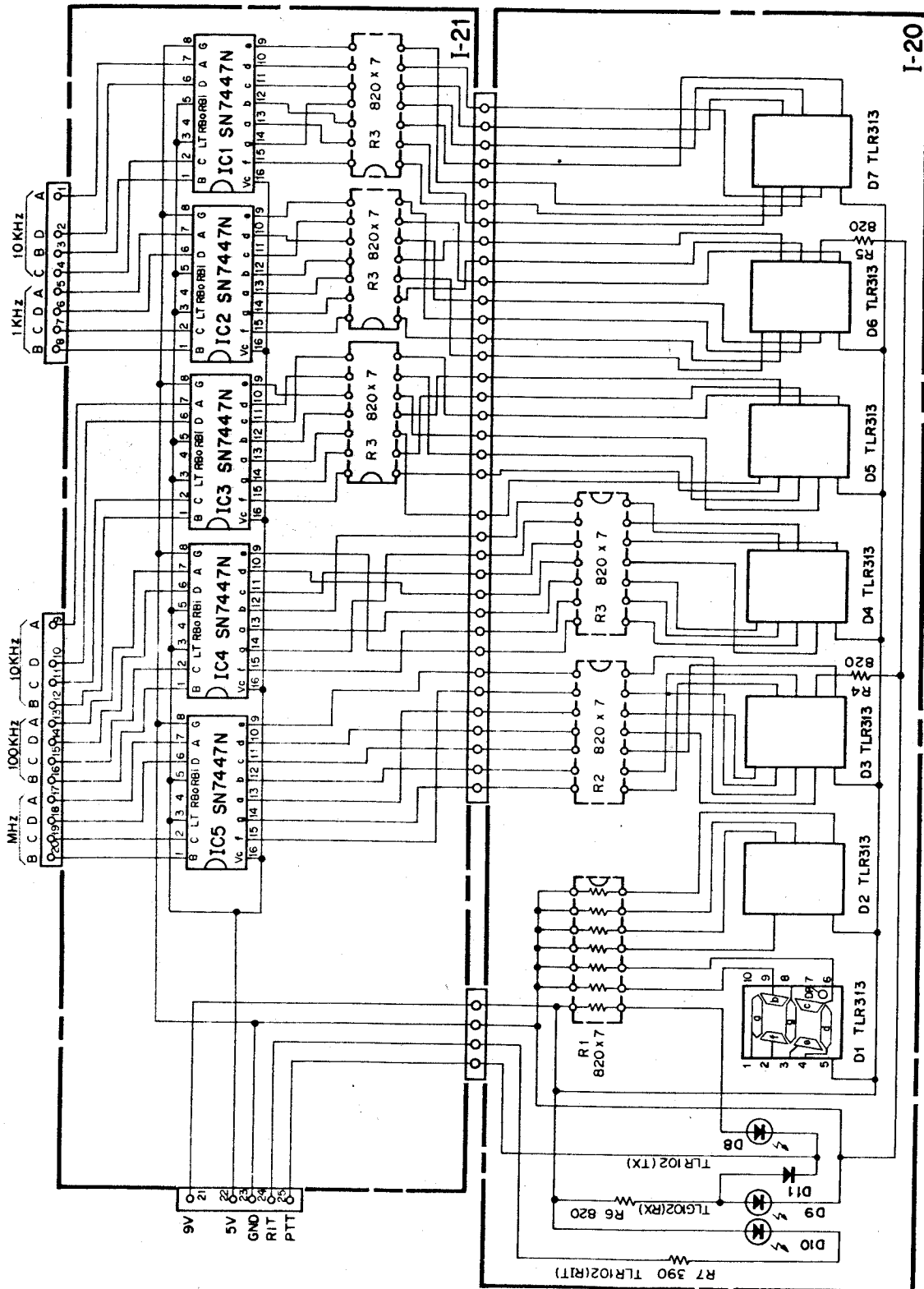

# DUPLEX UNIT

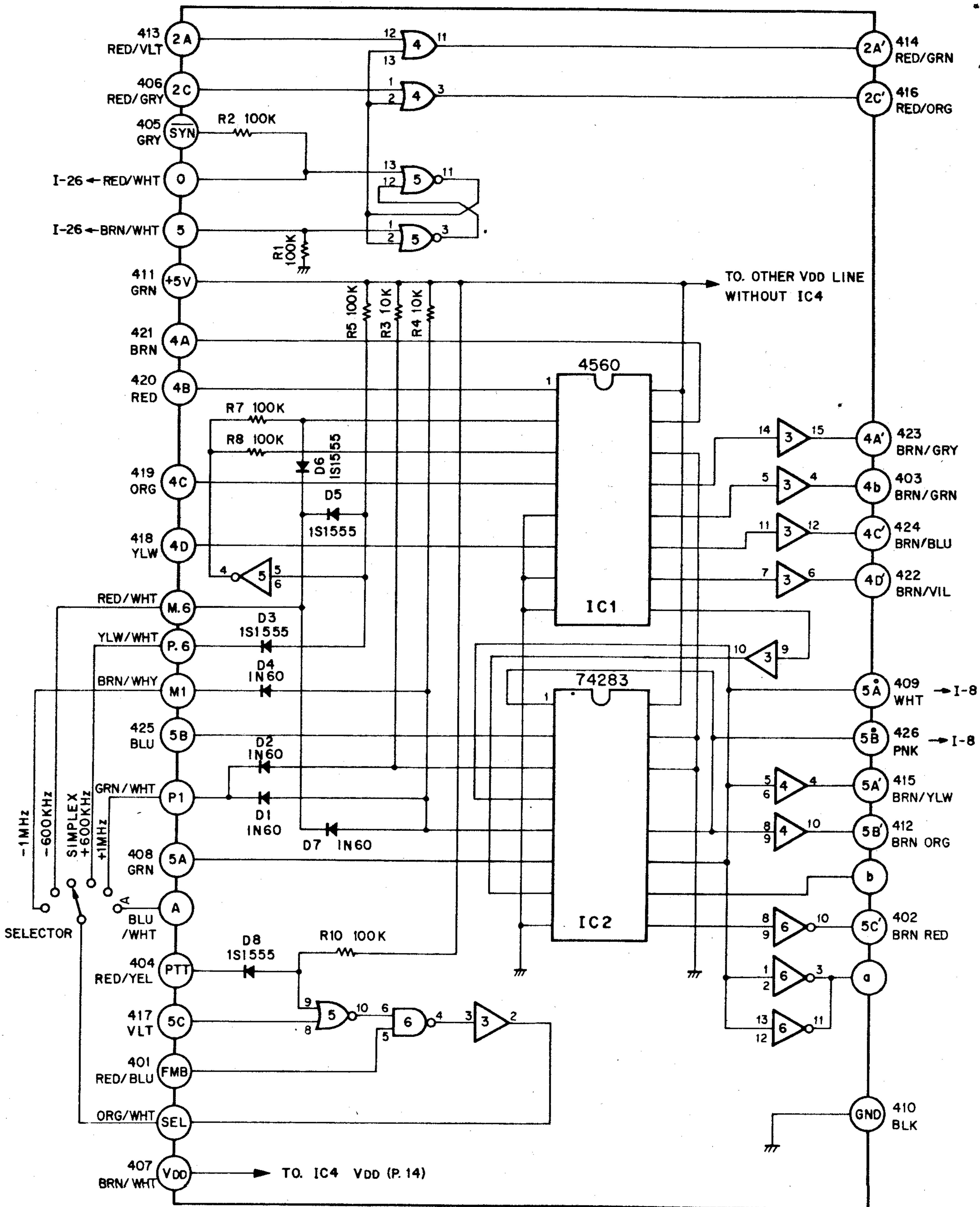

- |                |            |
|----------------|------------|
| IC 1. TC4560 P | 4. TC4071  |
| 2. SN74283     | 5. TC4001  |
| 3. TC4050P     | 6. TC4011P |