

ASSEMBLING
and
OPERATING
the

hallicrafters

model HT-40K
Transmitter

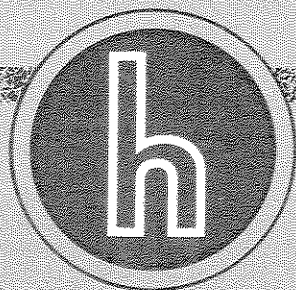

the hallicrafters co.

4401 WEST FIFTH AVENUE • CHICAGO 24, ILLINOIS

AMENDMENT I

MODEL HT-40K INSTRUCTION MANUAL

These instructions amend the Instruction Manual for the Model HT-40K Transmitter Kit.

It is suggested that these changes be incorporated into the Instruction Manual.

On page 33 change step 7 to read:

- () Cut the leads of L2 a 1 millihenry choke (brown-black-red), to 1/2 inch on each end. Connect one lead of L2 to terminal 1 of TS-8 (S-4).

On page 36 change steps 10 and 11 (installation of L12) to read:

- () Cut the leads of R31, a 100 ohm, 5 watt, wire wound resistor (square body) to 3/4 inch on each end. Connect one lead of R31 to terminal 1 of TS-5 (S-2).
- () Connect the other lead of R31 to terminal 3 of socket XV2 (S-2).

In the Schematic Diagram on page 5 and in Pictorial 6 on page 26 and the fold out change L12 to R31. In the Parts List change item 106 (L12) a .33 MH cathode choke (053-000599) to item 106 (R31) a 100 ohm, 10%, 5 watt, wire wound resistor (445-012101). Also, in the Parts Illustration delete the illustration of the .33 MH cathode choke and add the following illustration.

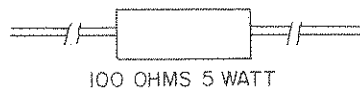

Pack with Instruction Manual
094-902601
Form Number 094-902661

SPECIAL NOTICE

MODEL HT-40K

Where yellow wire is called for in the assembly procedures use the white wire furnished with the kit.

Where No. 16 bare tinned wire is called for in the assembly procedures use the No. 14 bare tinned wire furnished with the kit.

On page 6 in the first line, change .5 mfd capacitor to read .47 mfd 400V capacitor.

On page 14, step 7, after C17 insert in parenthesis (wide plate spacing).

On page 29, step 5 change terminal 3 of TS-12 (S-2), to read terminal 3 of TS-13 (S-2).

On page 29, step 11 change C31, a .001 MFD 500V disc capacitor, to read C31, a .001 MFD, 1KV disc capacitor.

On page 30, step 9, after .001 MFD insert 500 volt.

On page 34, step 18 change C8, a .005 MFD 1KV ceramic disc capacitor to read C8, a .005 MFD, 500V ceramic disc capacitor.

On page 35, Pictorial 7 change C3, .005, 1 KV to read C3, .005, 500 volt.

On page 36, steps 4 and 5 change R6 to read R11.

On page 36, step 16 change C23, a .005 MFD 1 KV ceramic disc capacitor, to read C23, a .005 MFD, 500V ceramic disc capacitor.

On page 38, step 14 add the following sentences. In the illustrations of various components the diodes shown have the K or cathode terminal identified as follows:

- plus (+) mark
- K mark
- red stripe
- vertical line of diode symbol

The illustration for circuit symbols shows a rectifier which is the same as a diode. The triangle portion of the symbol should be shown as solid black. The end of the diode marked with the vertical line of the symbol is the K or cathode terminal (→^K).

On page 39, step 16 change socket XV4 to read socket XV2.

On page 43, step 19, change the last sentence to read, Connect one lead to terminal 2 of TS-4 (S-2).

On page 39, step 21 change lead No. 2 to read lead No. 3.

On page 46, step 7 change C3, a .005-1KV ceramic disc capacitor to read C3, a .005 mfd, 500V ceramic disc capacitor.

On page 46, step 13 add (S-1) at the end of the sentence.

On page 48, after step 3 insert the following step: Install the bandswitch shield (shield, electrical, item 22), as shown in the bottom view of the completed transmitter chassis (located on the back of page 55) using two No. 6 x 1/4 thread forming screws.

On page 48, after step 12 insert the following step: Cut a piece of No. 22 bare tinned wire 1 inch long and connect across terminals 3 and 4 of the four-connector board on the rear of the chassis. This jumper wire must be in place at all times except when connections are made to terminals 3 and 4 for remote control operation.

On page 49 under EQUIPMENT REQUIRED, item 1 add the following: With reference to RF OUTPUT - GRID CURRENT meter on page 4 and in steps 7 through 14 on pages 52 and 53, the RF OUTPUT meter reading will be most accurate when the load impedance is 52 ohms resistive. When using a 40 watt light bulb for initial checks it is recommended that the meter terminals be shunted with a 470 ohm, 1/2 watt resistor. Off scale meter deflections, when the antenna is connected, indicates an excessive VSWR. Should it be necessary to operate temporarily with a high VSWR, the 470 ohm, 1/2 watt resistor should be left across the meter terminals.

LABEL PLACEMENT INSTRUCTIONS

After the chassis has been completely wired and before it is placed into the cabinet, attach with a household glue or cement the tube location label, the power consumption label, the serial No. tag, and the license (patent) label to the chassis or cabinet as indicated below:

Glue the serial number tag (detached from the warranty registration card) to the chassis just above the power cord. Cut a small notch in the bottom of the tag so that it fits over the line cord lock as shown below. This will allow the serial number to be visible with the chassis in the cabinet.

Glue the tube location label to the left on the inside of the cabinet, the power consumption label on the right rear of the cabinet, and the license (patent) label on the left rear of the cabinet.

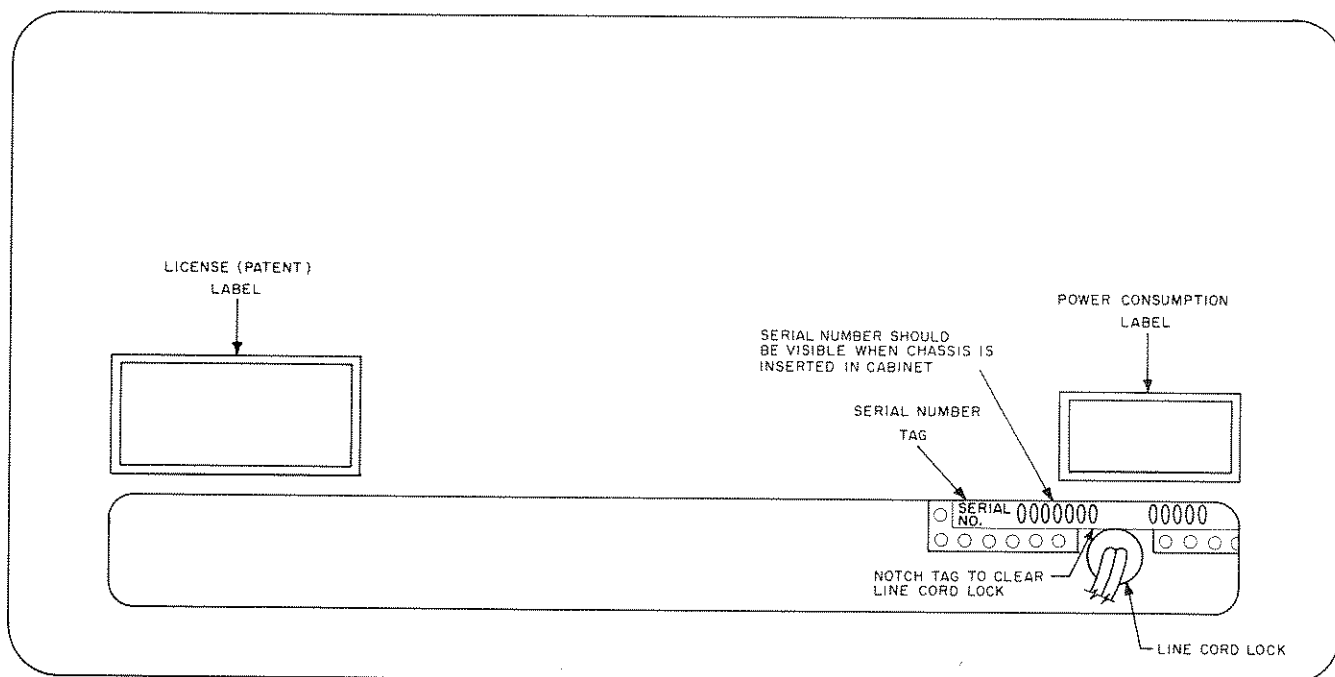

092-010595

Pack With The Model HT-40K

Manual 094-902601

Form Number 094-902642B

Subject: Additional information for the Model HP-40K
transmitter kit.

Dear Mr. Moore:

We are pleased to enclose a special notice bulletin and amendment I providing information relative to changes in the instruction manual for the model HP-40K transmitter kit.

Amendment I describes the addition of a 100 ohm 5 watt wire wound resistor #45-012101 which is enclosed at no charge.

May we take this opportunity to wish you a great deal of enjoyment from the operation of your Hallicrafters kit.

73

Cordially yours,

THE HALLICRAFTERS CO.



A. R. Dambrowskas, W9CXE
National Service Manager

ARD/jr1

Encl. #45-012101
094-902661
094-902642B

the hallicrafters co.

V4
6DE7

2ND A.F. AMPLIFIER
MODULATOR

V1
6CX8

OSC. & BUFFER

V3
12AX7

MICROPHONE INPUT &
1ST A.F. AMPLIFIER

V2
6DQ5

FINAL R.F. AMPLIFIER

REAR OF CHASSIS

TOP OF CHASSIS
TUBE LOCATIONS
MODEL HT-40

031-003739

FEATURES AND SPECIFICATIONS

TYPES OF EMISSION

AM. Amplitude modulation
 CW. Continuous wave

FREQUENCY SELECTION. Crystal controlled or external VFO

FREQUENCY COVERAGE 80, 40, 20, 15, 10, and 6 meter bands

POWER INPUT

AM. 75 watts peak power
 CW. 75 watts maximum

AUDIO INPUT004 V minimum at input to microphone jack

DISTORTION8% at 75% modulation

HUM AND NOISE OUTPUT.40 db or more below maximum output

TUBES Four, plus two silicon rectifiers

POWER SOURCE. 105-125 volts, 60 CPS, AC

OUTPUT COUPLING. Pi network

POWER CONSUMPTION 175 watts

RF OUTPUT IMPEDANCE 50 to 75 ohm coaxial, connector accepts Amphenol 83-1SP connector

CW KEYING Panel mounted key jack accepts standard 2-connector 1/4" plug

MICROPHONE INPUT Rear chassis mounted microphone receptacle Amphenol 75-MCIF connector

DIMENSIONS 7-3/16" high, 13-3/8" wide, 8-1/4" deep

NET WEIGHT 17 pounds

SHIPPING WEIGHT. 19 pounds

FREQUENCY COVERAGE

Band	Transmitter Frequency Range	Crystal or VFO Frequency Range
80	3.5 MC to 4 MC	3500 KC to 4000 KC
40	7 MC to 7.3 MC	3500 KC to 3650 KC 7000 KC to 7300 KC
20	14 MC to 14.35 MC	7000 KC to 7175 KC
15	21 MC to 21.45 MC	7000 KC to 7150 KC
10	28 MC to 29.7 MC	7000 KC to 7425 KC
6	50 MC to 54 MC	8333 KC to 9000 KC

Note: 1000 KC = 1 MC

WARRANTY

The Hallicrafters Company warrants each part or component supplied with this kit to be free of defective material and workmanship, and agrees to replace any part or component that, under normal installation, use, and service, discloses such defect. Upon return of the intact part or component to the factory, for examination, with all transportation charges prepaid, within ninety days from the date of sale to original purchaser, and provided that such examination discloses in our judgement that it is thus defective, it will be replaced.

This warranty does not extend to any parts or components supplied with this kit that have been subjected to misuse, neglect, accident, incorrect wiring, improper installation, or use in violation of instructions furnished by us, nor does this warranty extend to units that have been repaired or altered outside of our factory, or to accessories used therewith not of our own manufacture. No replacement will be made for parts damaged by the purchaser during the assembling or handling of this kit.

Hallicrafters liability under this warranty is limited to the replacement of the part or component part determined to be defective. The Hallicrafters Company assumes no liability for consequential damages including but not limited to personal injury, damage to property and loss of time. This warranty is in lieu of all other warranties expressed or implied, and no representative or person is authorized to assume for us any other liability in connection with the sale of our radio products.

IMPORTANT NOTE

THIS WARRANTY WILL BE COMPLETELY VOID AND THE HALLCRAFTERS COMPANY WILL NOT REPLACE, REPAIR, OR SERVICE EQUIPMENT IN WHICH ACID CORE SOLDER OR PASTE FLUXES HAVE BEEN USED.

The registration card furnished with each Hallicrafters kit must be completed and returned to The Hallicrafters Company immediately after purchase. The above warranty applies only to equipment that is registered with Hallicrafters.



Figure 1. Model HT-40K Transmitter.

INTRODUCTION

GENERAL

The Hallicrafters Model HT-40K Transmitter Kit is designed to operate on the 80, 40, 20, 15, 10, and 6 meter bands.

A few of the features of the HT-40K include: 75 watts input with high efficiency output capability, either crystal or external VFO control, full carrier-controlled amplitude modulation (AM) and Continuous Wave (CW) transmission. Internal switching connected to a terminal board on the rear of the HT-40K permits the Transmitter to control or be controlled by accessory equipment such as the SX-140 or the SX-140K Receiver. Special attention was given in the selection of the components and the internal circuit arrangement to reduce Television Interference (T.V.I.) to a minimum.

It is assumed for all practical purposes that many kits will be constructed by people new to the radio and electronic field or who pursue other fields and construct kit items for a diversion. Because of this, extreme care has been exercised in the preparation of the manual in the step-by-step procedure for mounting the parts, soldering, and final testing of the kit so that questionable meanings of the steps do not exist. **IT IS TO BE EMPHASIZED THAT THE BUILDER CAREFULLY READ THE MANUAL BEFORE ATTEMPTING TO BUILD THE KIT SO THAT MISTAKES DIFFICULT TO CORRECT WILL NOT OCCUR.**

A kit which is wired and soldered neatly and correctly will afford the builder complete satisfaction in operation. To achieve this result, we suggest that a particular space be used for the building of the kit and the arrangement of parts and tools. Parts which are easily scratched or marred should be placed on a soft cloth away from the construction area. By setting up the construction space in this order, you minimize the possibilities of using incorrect parts and insure successful construction of the kit.

HT-40K Transmitter utilizes a built-in oscillator circuit or external VFO for the desired fundamental signal that is to be amplified straight through, or operated as a harmonic to produce the desired output frequency on each band. Circuits are employed in the transmitter to permit operation at any desired frequency in the 80, 40, 20, 15, 10, and 6 meter bands on CW (continuous wave) or AM (amplitude modulation). Screen injection or carrier control modulation is provided for phone transmission.

CRYSTAL OSCILLATOR. - The triode section of V1 (6CX8) is used in a modified Pierce Type of crystal oscillator circuit. In this circuit, feedback energy is fed from the plate to the grid by means of a 4700 mmf capacitor in series with the crystal. The grid circuit elements consist of a 47K ohm grid return resistor shunted by a 22 mmf capacitor loading capacity. The plate circuit utilizes a 2.5 MH choke as a common fixed plate load for all frequencies of operation. Coupling from the oscillator plate to buffer grid is accomplished with a 1000 mmf capacitor.

When operating the Transmitter with external VFO, the crystal is removed from the pin jacks and the VFO output terminals are connected to the pin jacks. The high side of the VFO output is connected through the red jack to the grid of V1 (6CX8) and the ground side of the VFO output is connected through the black jack and switch S1 in the VFO position, to ground. When S1 is in the VFO position the 4700 mmf feedback capacitor is disconnected from the circuit.

During CW operation the cathode of this tube is switched to and from ground with the operation of the key.

BUFFER-MULTIPLIER. - The pentode section of V1 (6CX8) is operated as a buffer multiplier. The signals are fed from the oscillator circuit to the grid of the buffer and amplified or multiplied by this stage operating in class C. The buffer plate load consists of a shunt fed 1 MH choke coupled to the grid of the final amplifier tube V2(6DQ5) by means of a pi network with separate inductances for each band. The network input is tuned with the DRIVE capacitor and the network output is terminated with a 33 mmf capacitor connected to the 6DQ5 grid circuit. Because of the proper selection of coils in each band, it is impossible to tune to a harmonic of the output frequency with the DRIVE capacitor. This reduces the possibility of undesirable signals being fed to the antenna and keeping television interference to a minimum.

FINAL AMPLIFIER STAGE. - The final amplifier stage utilizing a 6DQ5 beam powered pentode tube operates as a "straight through" amplifier on the 80 through 10 meter bands and as a frequency doubler on the 6 meter band. The final amplifier plate load consists of a shunt fed RF choke capacitively coupled to the pi section network. The input of the network is tuned with the PLATE TUNING capacitor, and is terminated with the PLATE LOADING capacitor for matching the plate impedance to the impedance of the antenna. A tapped coil (L10) is used for the 80 through 10 meter bands, the 6 meter band uses a separate coil (L9) connected at right angles to L10 so that a minimum of mutual inductance exists between them. A sensitive meter (M1) is used in this circuit to measure grid current and output power.

RF OUTPUT-GRID CURRENT METER. - The RF OUTPUT-GRID CURRENT meter, a basic 5 mil movement graduated in 5 units (0-5), and its circuitry perform two important functions:

1. With the switch S4 in the GRID CURRENT position the final amplifier grid current can be measured, each division indicates approximately 1 milliampere.
2. With switch S4 in the RF OUTPUT position the output power delivered to the antenna can be measured. Each division on the meter represents approximately 10 watts, therefore if a deflection of three and a half divisions is indicated, 35 watts are being delivered to the antenna ($3.5 \times 10 = 35$).

SPEECH AMPLIFIER AND MODULATOR. - The speech amplifier section of the audio system consists of the two triode sections of V3 (12AX7) and one triode section of V4 (6DE7) RC coupled and operated in cascade to develop an adequate signal input to the modulator (second triode section of V4). The modulator has a low plate resistance and acts as a high level cathode follower. The screen impedance of the 6DQ5 (the modulated element) becomes an appreciable portion of the cathode follower impedance. The audio frequency component of the cathode follower is applied in full to the screen of the final ampli-

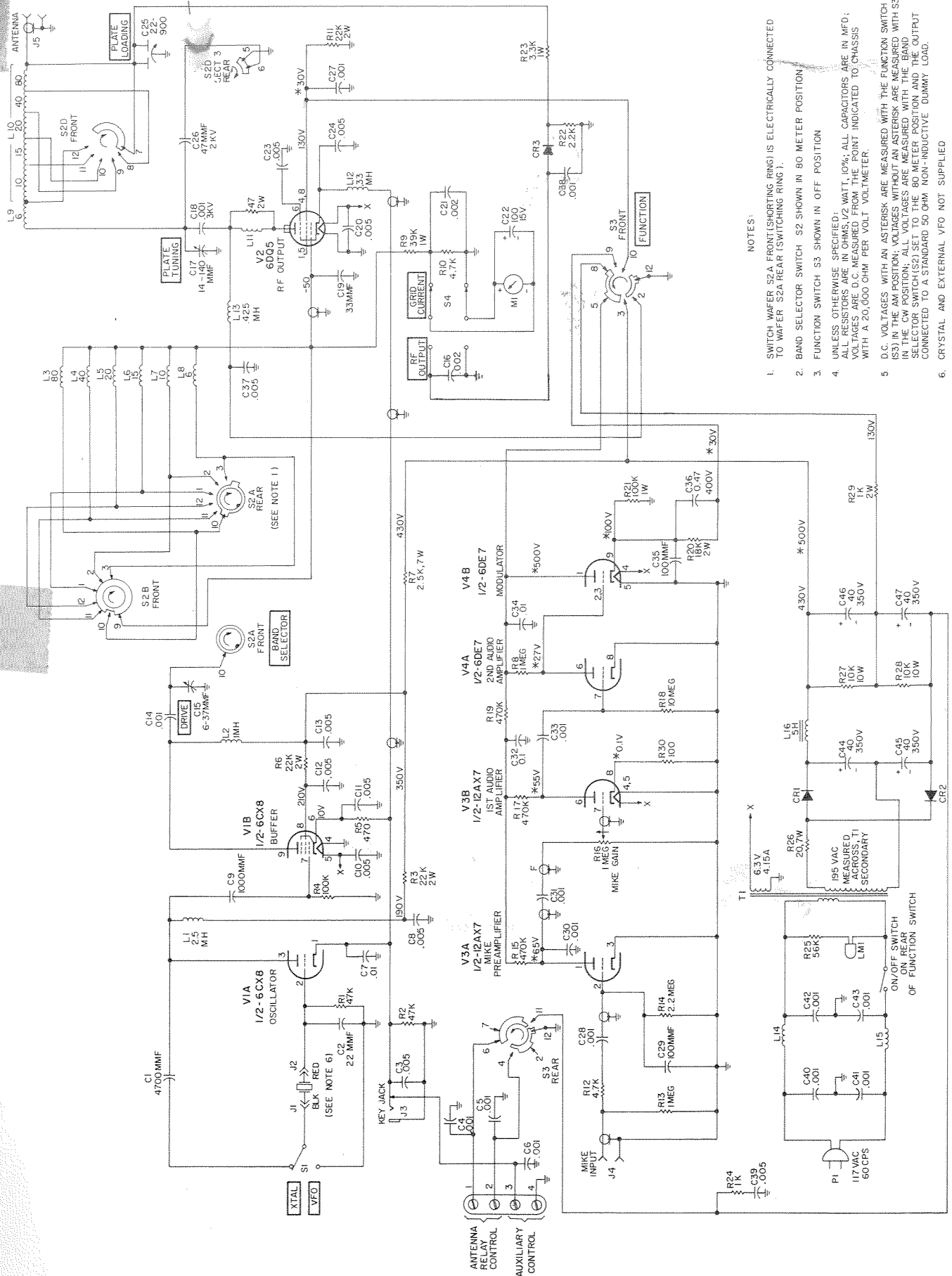

- NOTES:
- SWITCH WAFER S2A FRONT(SHORTING RING) IS ELECTRICALLY CONNECTED TO WAFER S2A REAR (SWITCHING RING).
 - BAND SELECTOR SWITCH S2 SHOWN IN OFF POSITION
 - FUNCTION SWITCH S3 SHOWN IN OFF POSITION
 - UNLESS OTHERWISE SPECIFIED: ALL RESISTORS ARE IN OHMS, 1/2 WATT, 10%; ALL CAPACITORS ARE IN MFD; VOLTAGES ARE D.C. MEASURED FROM THE POINT INDICATED TO CHASSIS WITH A 20,000 OHM PER VOLT VOLTMETER.
 - D.C. VOLTAGES WITH AN ASTERISK ARE MEASURED WITH THE FUNCTION SWITCH IN THE OFF POSITION. ALL VOLTAGES ARE MEASURED WITH THE BAND SELECTOR SWITCH(S2) SET TO THE 80 METER POSITION AND THE OUTPUT CONNECTED TO A STANDARD 50 OHM NON-INDUCTIVE DUMMY LOAD.
 - CRYSTAL AND EXTERNAL VFO NOT SUPPLIED
 - SECTION C OF S2 IS USED FOR COMMON THE POINTS.

Figure 2. Model HT-40K Schematic Diagram.

fier (6DQ5) tube through a .5 mfd capacitor to permit modulation of the screen. An RF filter between the microphone jack and the grid of the MIKE preamplifier (V1A) eliminates distortion in the system which could be caused by RF across the microphone jack.

POWER SUPPLY. - The DC voltage to operate the Transmitter is obtained by rectifying the AC voltage across the secondary of the power transformer T1 with a full wave voltage doubler circuit using two silicon diode rectifiers. Adequate filtering of the power supply is accomplished by the voltage doubler circuit, together with the choke and output filter capacitors.

Another secondary winding of the power transformer furnishes filament voltage for all of the tubes in the transmitter.

To prevent television interference from being conducted back through the power cord to the power line an LC filter is connected across the power transformer primary.

OPERATOR CONTROLS

FUNCTION CONTROL. - The FUNCTION control, a five-position rotary switch is used to select the Transmitter mode of operation as indicated.

1. OFF position; AC power is disconnected from the power transformer primary.
2. TUNE position; power is applied to the oscillator and buffer stages but not to the modulator and final amplifier stages. Grid current is adjusted with the DRIVE control for maximum indication on the RF OUTPUT - GRID CURRENT meter.
3. STANDBY position; the negative side of the DC power supply is disconnected from the internal circuitry. Provision is made for remote control switching.

NOTE

A unique feature of the power supply allows current to be constantly fed through the bleeder when in the STANDBY position, thus providing better voltage regulation when switching from STANDBY to AM or CW.

4. AM position; power is applied to the oscillator, buffer, speech amplifier, final amplifier and modulator stages.
5. CW position; power is applied to the oscillator, buffer and final amplifier stages but is removed from the modulator stage. Screen voltage for the 6DQ5 is obtained from the tap on the bleeder connected across the power supply.

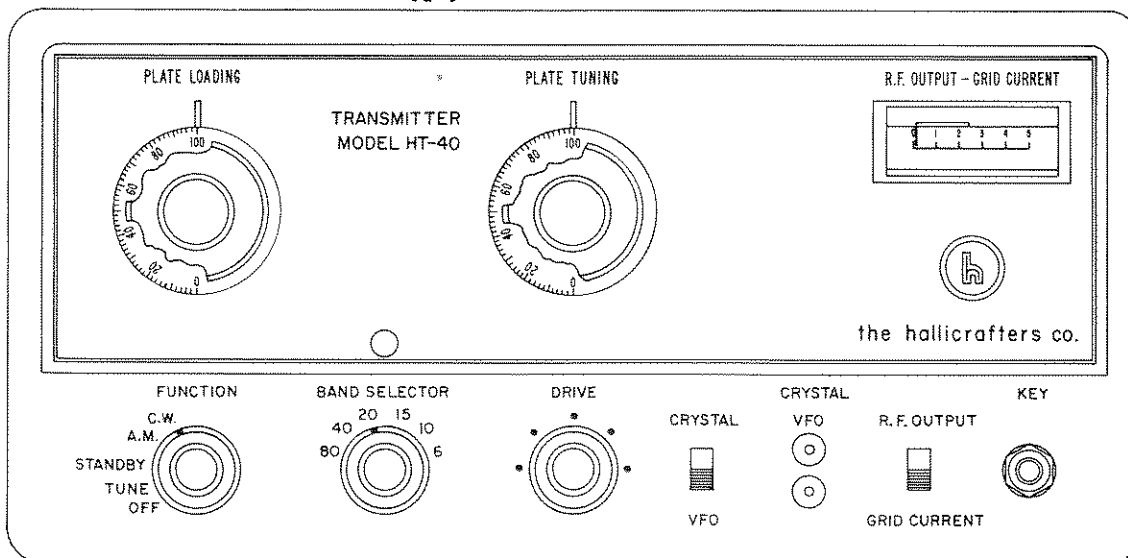

092-01041

Figure 3. Model HT-40K Front Panel Controls and Indicators.

BAND SELECTOR CONTROL. - The **BANDSELECTOR** is a six-position multi-section rotary switch used to select the proper inductance in the driver and final amplifier pi network for each band.

DRIVE CONTROL. - The **DRIVE** control is a variable capacitor used to tune the plate circuit of the buffer stage. This control also functions as the input tuning capacitor of the pi network between the output of the buffer stage and the input to the final amplifier stage. Operation of this control is such that it is impossible to tune to a harmonic of the desired output frequency.

CRYSTAL-VFO SWITCH. - The **CRYSTAL-VFO** switch is a SPDT slide switch which permits the HT-40K to operate either crystal controlled or to operate from an external VFO.

RF OUTPUT-GRID CURRENT SWITCH. - The **RF OUTPUT-GRID CURRENT** switch is a DPDT slide switch which permits the operator to switch the meter either into the grid circuit of the final amplifier (6DQ5) or across the RF output load.

PLATE LOADING CONTROL. - The **PLATE LOADING** control is a variable capacitor in the output of the pi network section which adjusts the plate load impedance thus matching the Transmitter to the antenna.

PLATE TUNING CONTROL. - The **PLATE TUNING** control is a variable capacitor which tunes the plate circuit of the final amplifier (6DQ5) to the desired operating frequency.

MIKE GAIN CONTROL. - The **MIKE GAIN** control, a 1 megohm potentiometer located on the chassis rear, controls the audio signal applied to the grid of the audio amplifier tube V3B.

UNPACKING

After carefully reading the manual unpack the items of the Model HT-40K Transmitter Kit. Check the quantity and value of each component against the parts list and accompanying illustrations. It is suggested that each package of parts be checked as they are removed from the carton. Should missing, incorrect, or broken parts be discovered, notify the dealer from whom the kit was purchased or The Hallicrafters Company for proper authorization for returning broken parts or obtaining missing parts.

NOTE

The variable capacitors are packed with their plates fully meshed (see figure 4). To prevent damage or bending of the plates it is important that they be fully meshed at all times during construction of the kit. If the plates are accidentally bent they will rub or short against the stationary plates when the capacitor is tuned.

In the design of the Hallicrafters HT-40K Transmitter Kit only the highest quality components were used throughout. To ensure neat wiring and eliminate obscure electrical problems, a prefabricated cable harness has been prepared for easy wiring. Critical lead placement is automatically taken care of with the use of this pre-fabricated cable.

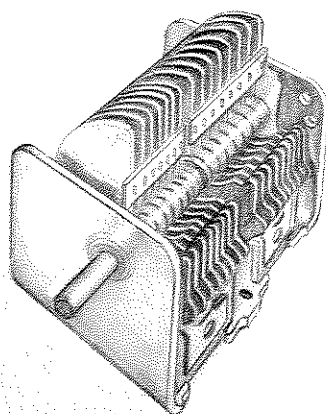

CAPACITOR HALF OPEN
(HALF MESHED)

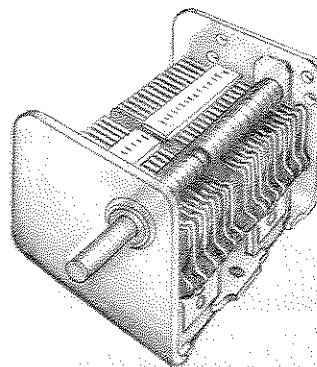

CAPACITOR CLOSED
(FULLY MESHED)

Figure 4. Variable Capacitor, Open and Closed.

TOOLS REQUIRED

The Model HT-40K Transmitter Kit can be constructed with standard tools. Tools that the builder should have available are long nose pliers, diagonal or side cutting pliers, a screwdriver with 3/16" blade, a screwdriver with a 1/8" blade and a soldering iron (preferably one with a heating element of not more than 47-1/2 watts).

SOLDERING TECHNIQUES

The proper soldering techniques are very important in the assembly of the kit. To obtain the performance engineered into this kit, it is essential that good solder joints be made. A good solder joint makes an electrical connection and seals the joint from air and moisture to prevent corrosion which could introduce high resistance into the circuit. It is suggested that should the kit builder be unfamiliar with soldering, the following steps and figure 5 be studied carefully.

IMPORTANT: Only good quality rosin core solder is to be used in the construction of this kit. A sufficient amount of rosin core solder is supplied with this kit. NEVER use acid core solder or a paste flux. The use of acid core solder or a paste flux will void the warranty on this equipment.

1. The soldering iron element or tip should be cleaned and tinned (covered with a thin coat of solder).
2. Before soldering, be sure the terminals and the leads are free from dirt and corrosion. Leads and terminals which are dirty or discolored (corroded) can be cleaned by scraping them with a knife.
3. Tin all wires and leads before making connections; this is accomplished by applying a small coating of solder to the lead.
4. Make a mechanical connection before soldering (see figure 5A). Leads should be kept as short as possible on small items (see figure 5B). (The part of the lead between the component and the point of soldering should be not less than 1/8".)
5. Apply heat to the connection with the flat portion of the soldering iron tip (see figure 5C). DO NOT apply more heat than is necessary to allow the solder to flow evenly over the connection. Make certain that heat is applied to the whole connection (leads and solder terminal). If heat is not applied evenly a "cold joint" (see figure 5D) will result and introduce resistance into the circuit.
6. Apply solder simultaneously to the connection and the tip of the soldering iron until the solder melts and flows around and into the connection. Apply only enough solder to cover the leads of the connection; do not apply an excessive amount of solder (see figure 5D). Never move the component that is being soldered until after the solder has cooled or solidified.
7. When soldering to a lug on a switch wafer the switch should be so positioned that the lug to be soldered is on the lower side of the wafer. It may be necessary to turn the chassis if the switch has already been installed. Apply heat and solder to the lower side of the lug; the solder will flow upward into the connection (see figure 5E). This method of soldering will prevent the solder from running into the switch and shorting the contacts.
8. Components such as rectifiers (CR1, CR2, and CR3) should be protected from heat when soldering. Long-nose pliers or alligator clips filled with solder placed on the lead between the component and the connection will conduct the heat away from the component (see figure 5F).

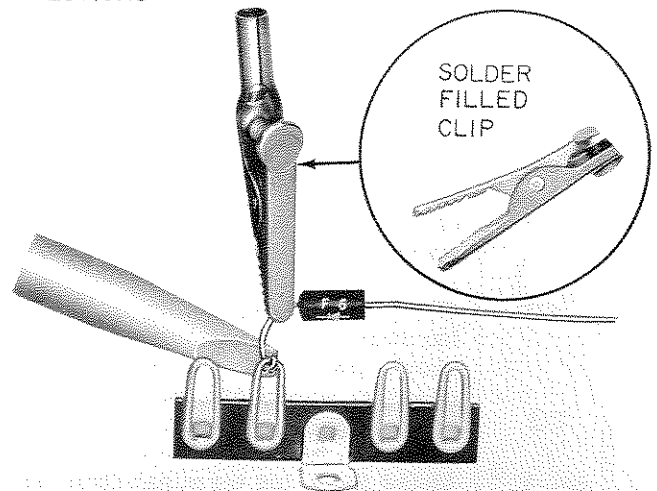
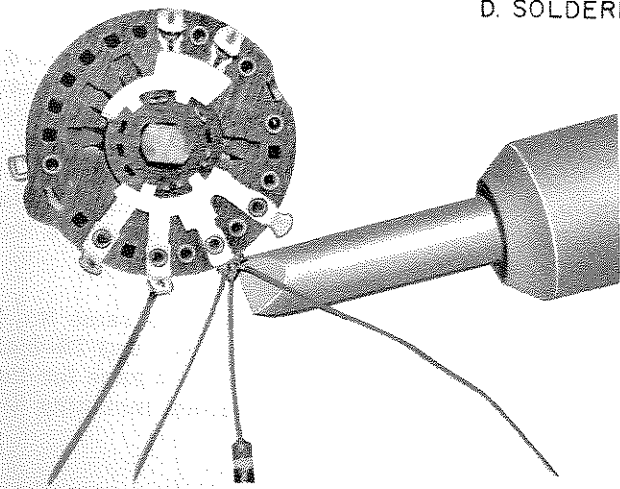
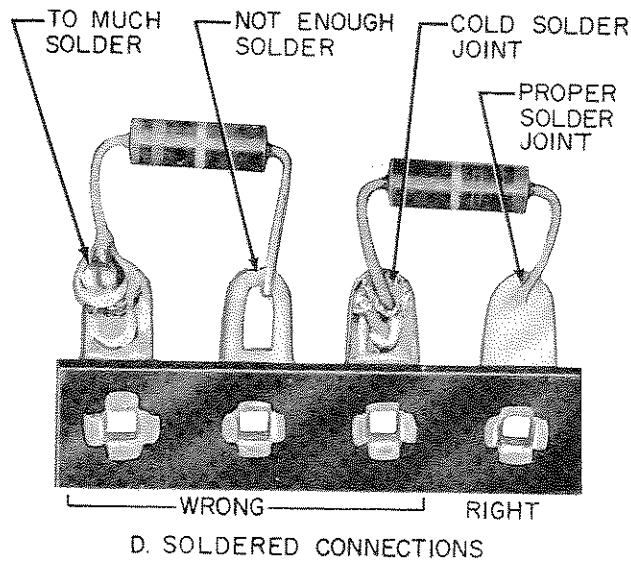
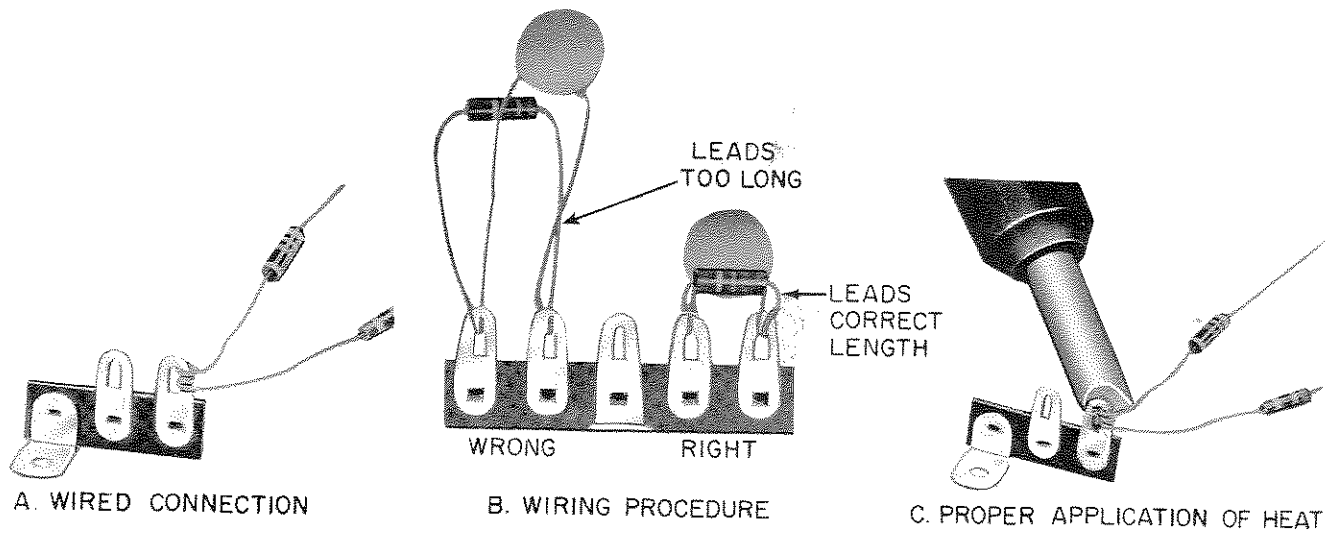

Figure 5. Wiring and Soldering Techniques.

ASSEMBLY INSTRUCTIONS

GENERAL

Each step of the assembly procedures which follows should be read and understood in its entirety before it is performed. When each step is completed place a check mark in the parentheses preceding the step.

Each assembly step involving the connection of wires or leads will be followed by a symbol in parentheses indicating if soldering is required or not, and how many leads will be soldered in the connection as follows:

Do not solder (DS)

Solder 1 lead (S-1)

Solder 2 leads (S-2)

Solder 3 leads (S-3)

Solder 4 leads (S-4)

Solder 5 leads (S-5)

WARNING

DANGEROUS VOLTAGES EXIST ON BOTH THE TOP AND BOTTOM OF THE CHASSIS. CAREFUL STUDY OF THE SCHEMATIC DIAGRAM AND CIRCUIT ARRANGEMENT WILL POINT OUT THESE DANGER SPOTS. HOWEVER, PRECAUTIONS SHOULD BE TAKEN TO KEEP OTHER PEOPLE AWAY FROM THE TRANSMITTER WHILE IT IS TURNED ON, OR WHEN IT IS BEING WORKED ON.

STEP BY STEP ASSEMBLY PROCEDURES

COMPONENT MOUNTING

Pictorial 1 shows the bottom of the chassis with the various holes numbered or lettered to aid the builder in locating the correct mounting holes for each item.

- () Mount the power transformer T1 to the chassis as shown in Pictorial 2 and Figure 6. The leads are pushed through holes X and Y and the transformer is mounted through holes 1, 2, 3, and 4. Feed the two black wires through hole X, the two green wires and the two red wires through hole Y.
- () Orient the transformer mounting feet with the holes in the chassis, securing it to the chassis first at hole 1 and hole 2 with the No. 6 x 3/8" long machine screws, No. 6 flat washers and No. 6 kep nuts as shown in Figure 6 and Pictorial 2.
- () Complete the mounting of the transformer through holes 3 and 4, with the same No. 6 hardware as mentioned above adding the two 4-lug terminal strips TS-1 and TS-2 as shown in Figure 6 and Pictorial 2. Mounted the transformer acts as a base for the chassis which can now be set on end or on its rear flange to facilitate mounting the remaining components.
- (✓) Mount the 3-lug terminal strip TS-3, at hole 5 using a No. 4 x 5/16" sems screw, a No. 4 internal tooth lock washer and a No. 4 hex nut as shown in Pictorial 2.
- (✓) Mount the 4-lug terminal strip TS-4, at hole 6 using a No. 4 x 5/16" sems screw, a No. 4 internal tooth lock washer, and a No. 4 hex nut as shown in Pictorial 2.

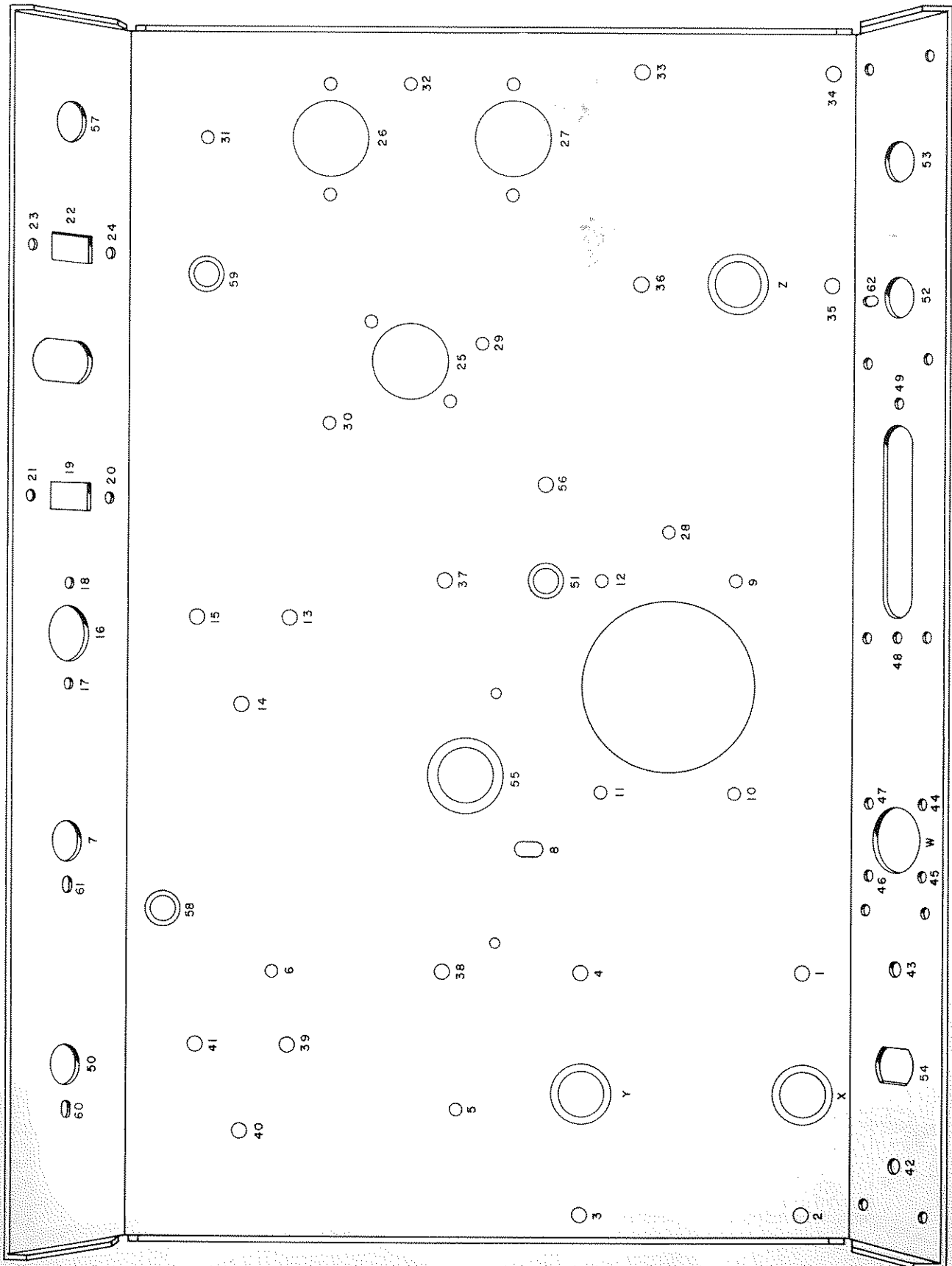

Pictorial 1. Chassis Numbering Sequence.

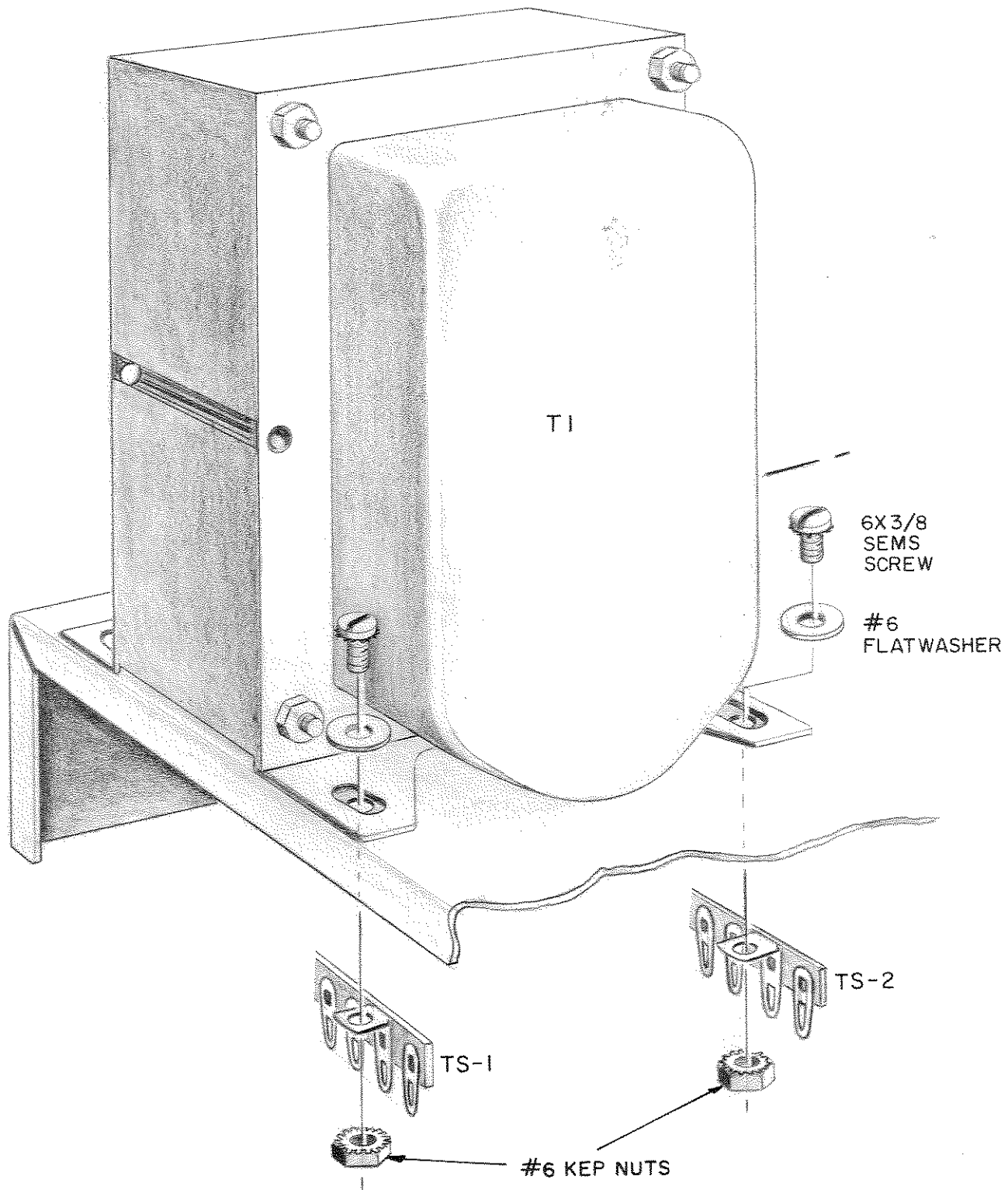
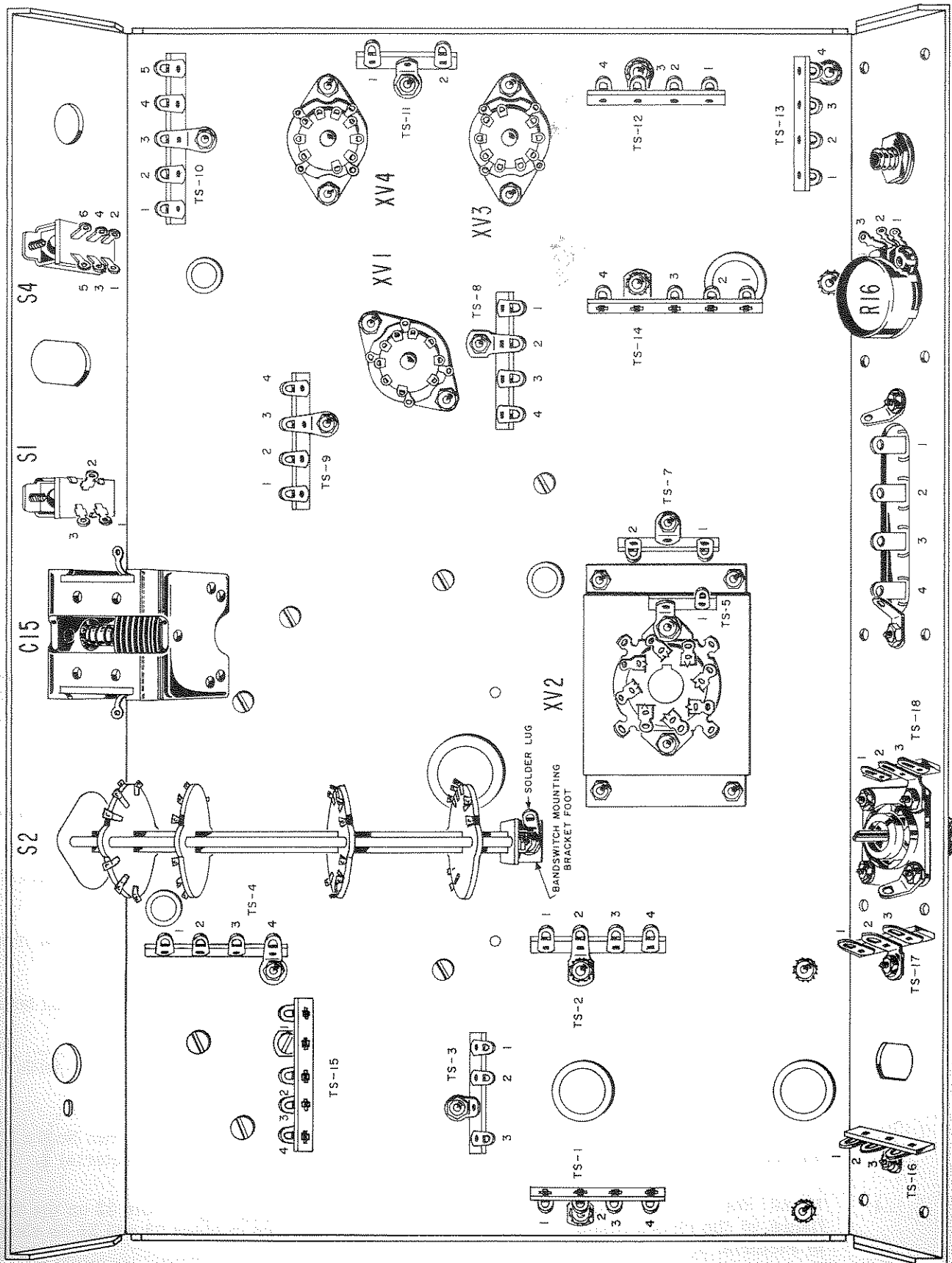

Figure 6. Mounting of Transformer T1.



Pictorial 2. Mounting of Components and Orientation on Chassis Bottom.

- (✓) Insert the threaded bushing of the bandswitch through hole 7 located on the front flange of the chassis, positioning the locating key in the slotted hole 61. In this position, the hole in the foot of the mounting bracket at the rear of the bandswitch will be in line with slotted hole 8 in the chassis.
- (✓) Thread the 3/8" black Palnut onto the bushing and finger tighten only as the nut will have to be removed later when the front panel is installed.
- (✓) Mount the rear bracket to the chassis with a No. 6 x 3/8" sems screw, a No. 6 solder lug, and a No. 6 kep nut as shown in Pictorial 2.
- (✓) Mount the octal socket XV2, together with the single-lug terminal strip TS-5 to the tube mounting bracket with the No. 4 x 5/16" sems screws, No. 4 lockwashers and No. 4 hex nuts as shown in Figure 7.
- (✓) Mount the tube mounting bracket, socket, and terminal strip assembly to the chassis through holes 9, 10, and 11 with No. 4 x 5/16" sems screws, No. 4 lockwashers, and No. 4 hex nuts, locating the assembly with the keyway and terminal strip as shown in Figure 8 and Pictorial 2.
- (✓) On the opposite side of the chassis from the tube mounting bracket assembly mount a 2-lug terminal strip TS-6 in hole 12 as shown in Pictorial 3 and Figure 8.
- (✓) Mount the plate tuning capacitor C17 at holes 13, 14, and 15 using three No. 6 x 1" sems screws and three 3/4" long brass spacers as follows:
- Insert the three 1" screws through holes 13, 14, and 15.
 - Slip the spacers over the screws, and thread the screws into the three tapped holes on the bottom of the capacitor as shown in Figure 9 and Pictorial 3 (do not use terminal strip). Before tightening the screws be certain that the front edge of the capacitor is parallel with the front edge of the chassis.
- (✓) Mount the drive capacitor C15 to the front flange at holes 16, 17 and 18 as shown in Figure 10 and Pictorial 2 using two No. 6 x 1/4" flat head screws and one 1/2" internal tooth lockwasher as follows:
- Slip the 1/2" internal tooth lockwasher over the capacitor shaft and insert the shaft into hole 16 on the front flange of the chassis.
 - Line up the tapped holes in the capacitor frame with holes 17 and 18 on the front flange.
 - Thread the two flat head screws through holes 17 and 18 and into the tapped holes of the capacitor.
 - Tighten the screws equally keeping the frame of the capacitor in line with the front flange.
- (✓) Mount the single-pole-double-throw (SPDT) slide switch S1 in hole 19 using two No. 4 x 1/4" flat head screws through holes 20 and 21. Orient the switch as shown in Pictorial 2.
- (✓) Mount the double-pole-double-throw (DPDT) slide switch S4 in hole 22 on the front flange of the chassis using two No. 4 x 1/4" flat head screws in holes 23 and 24 as shown in Pictorial 2.
- (✓) Mount the three 9-pin miniature sockets XV1, XV3 and XV4 together with the three tube shield bases in holes 25, 27, and 26, respectively, using No. 4 x 5/16" sems screws, No. 4 internal tooth lockwashers, and No. 4 hex nuts as shown in Pictorial

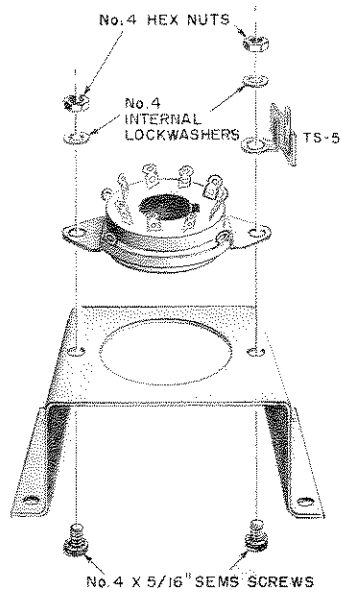

Figure 7. Mounting of Octal Socket.

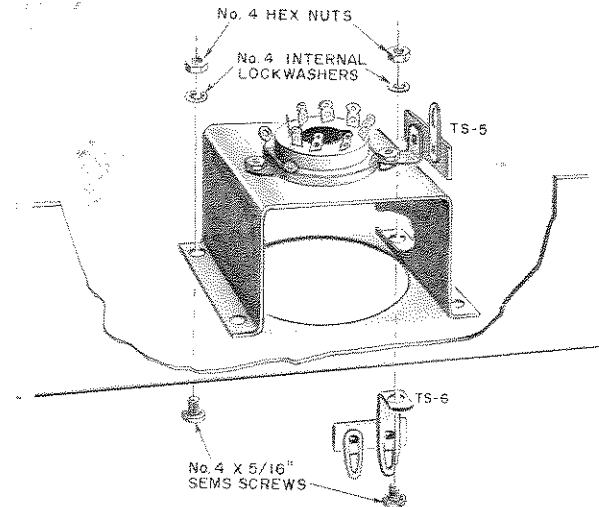

Figure 8. Mounting of Octal Socket and Bracket.

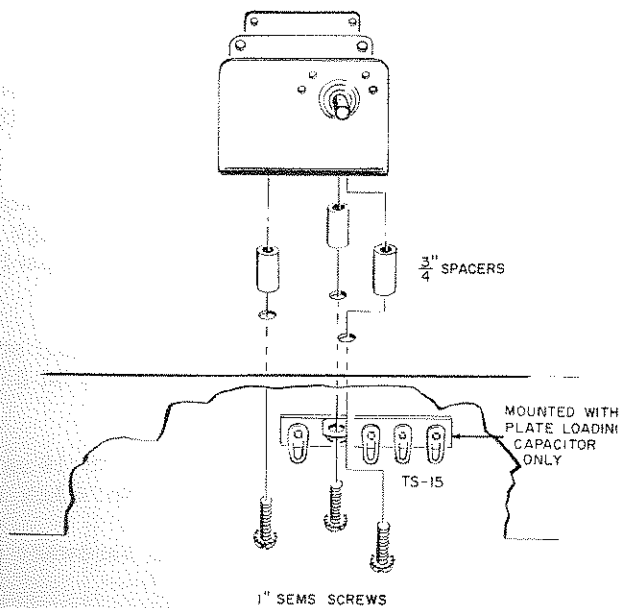

Figure 9. Mounting of Plate Tuning and Plate Loading Capacitor.

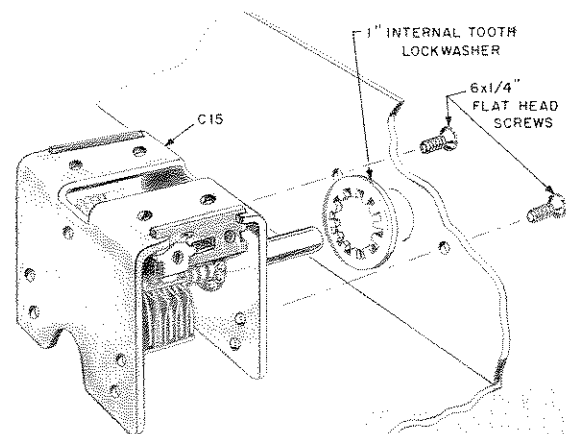
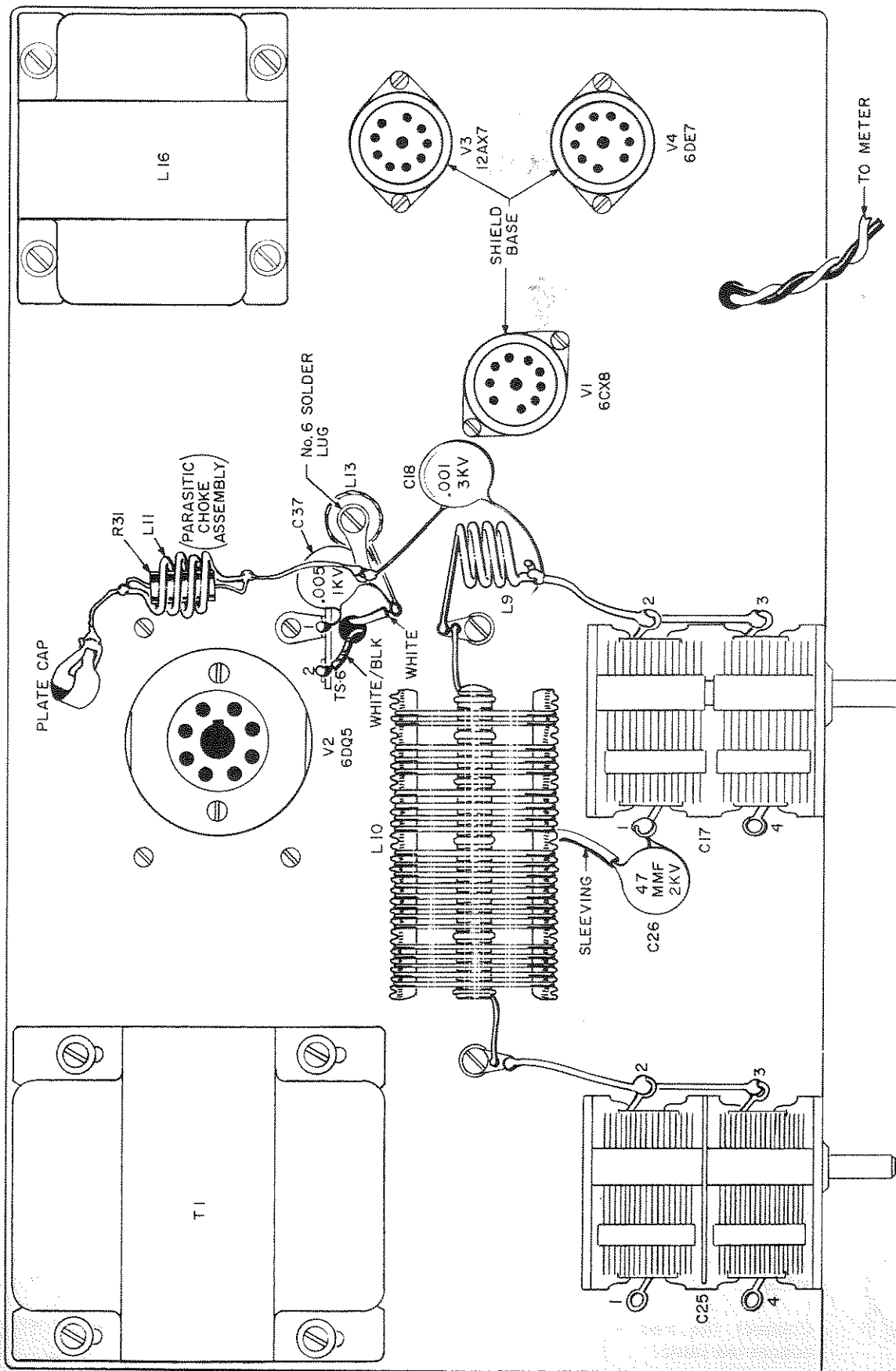

Figure 10. Mounting of Drive Capacitor.

2 and Pictorial 3. Make certain that the open spaces in the sockets (see Figure 11) are facing in the correct direction as shown in Pictorial 2.

- (✓) Mount the 2-lug terminal strip TS-7 in hole 28 using a No. 4 x 5/16" sems screw, a No. 4 internal tooth lockwasher, and a No. 4 hex nut as shown in Pictorial 2.
- (✓) Mount the 4-lug terminal strip TS-8 in hole 29 using a No. 4 x 5/16" sems screw, No. 4 internal tooth lockwasher, and No. 4 hex nut as shown in Pictorial 2.
- (✓) Mount the 4-lug terminal strip TS-9 in hole 30 using a No. 4 x 5/16" sems screw, a No. 4 internal tooth lockwasher, and a No. 4 hex nut as shown in Pictorial 2.
- (✓) Mount the 5-lug terminal strip TS-10 in hole 31 using a No. 4 x 5/16" sems screw, a No. 4 internal tooth lockwasher, and a No. 4 hex nut as shown in Pictorial 2.
- (✓) Mount the 2-lug terminal strip TS-11 in hole 32 using a No. 4 x 5/16" sems screw, a No. 4 internal tooth lockwasher, and a No. 4 hex nut as shown in Pictorial 2.
- (✓) Install filter choke L16 at holes 33, 34, 35 and 36 by passing the two black leads through hole Z in the chassis, orient the choke so that the black leads go directly through hole Z. Secure the choke to the chassis by using four No. 6 x 3/8" sems screws, four No. 6 flat washers and four No. 6 kep nuts, (similar to mounting transformer T1 as shown in Figure 6 except three 4-lug terminal strips TS-12, TS-13 and TS-14 are mounted underneath the chassis at holes 33, 34 and 36 respectively). Orient terminal strips as shown in Pictorial 2.
- (✓) Mount two standoff insulators that support the output tank coil L10 with No. 6 x 3/8" sems screws and two No. 6 fiber washers at holes 37 and 38 as shown in Pictorial 2 and Pictorial 3.
- (✓) Place a No. 6 solder lug and a No. 6 fiber washer on the top of each standoff insulator and secure to the insulator with a No. 6 x 3/8" sems screw as shown in Pictorial 3.
- (✓) Mount plate loading capacitor C25 at chassis holes 39, 40, and 41 using three No. 6 x 1" sems screws, and three 3/4" long spacers as follows:
 - a) Insert two No. 6 x 1" sems screws through holes 40 and 41. Slip a 3/4" spacer over each screw and thread the screws lightly into the tapped holes in the bottom of the capacitor frame (see Figure 9). Do not tighten.
 - b) Place a No. 6 x 1" sems screw through the mounting lug of 4-lug terminal strip TS-15, insert the screw through the bottom of the chassis in hole 39 through the spacer and thread the screw into the tapped hole on the bottom of the capacitor frame.
 - c) Tighten all three screws after orienting the capacitor frame and terminal strip TS-15 parallel with the front edge of the chassis as shown in Pictorial 2 and Pictorial 3.
- (✓) At hole 42 on the rear flange of the chassis mount a 3-lug terminal strip TS-16 using a No. 4 x 5/16" sems screw, a No. 4 internal tooth lockwasher, and a No. 4 hex nut.
- (✓) Mount terminal strip TS-17 at hole 43 as shown in Pictorial 2, using same hardware as previous step.
- (✓) Mount the antenna connector J5 on the rear chassis flange at holes W, 44, 45, 46 and 47 using four No. 4 x 5/16" sems screws, three No. 4 internal tooth lockwashers, a No. 6 solder lug and four No. 4 hex nuts as follows:
 - a) Insert the body of J5, from the inside of the flange, through hole W and secure



Pictorial 3. Mounting of Components and Orientation on Chassis Top.

the connector using No. 4 hardware at holes 46 and 47.

- b) Using No. 4 hardware, mount three lug terminal strip TS-18 and a No. 6 solder lug at holes 44 and 45, respectively. Orient as shown in Pictorial 2.

- (✓) Mount the four-connector board at holes 48 and 49 as shown in Pictorial 2 using two No. 4 x 5/16 inch sems screws, two No. 6 solder lugs and two No. 4 hex nuts.

WIRING OF POWER SUPPLY

- (✓) Connect the black leads of choke L16 (at hole Z); the short lead to terminal 2 of TS-14 (DS) and the long lead to terminal 1 of TS-2(DS). Dress both leads as shown in Pictorial 4.

- (✓) Connect the short black primary lead of transformer T1 (at hole X) to terminal 3 of TS-16(DS). The long black lead will be connected later in the assembly procedure, dress this lead to the front of the chassis as shown in Pictorial 4.

- (✓) Connect one of the green filament leads of transformer T1 (at hole Y) to terminal 2 of TS-1(S-1).

- (✓) Connect the other green filament lead of transformer T1 (at hole Y) to terminal 3 of TS-1(DS).

- (✓) Connect the long red high voltage secondary lead of transformer T1 (at hole Y) of hole Y to terminal 2 of TS-15(DS). Dress leads along chassis as shown in Pictorial 4.

- (✓) Connect the short red high voltage secondary lead of transformer T1 (at hole Y) to terminal 4 of TS-1(DS).

INSTALLING OF FRONT CABLE HARNESS WH-1

- (✓) Lay the cable in the chassis as shown in Pictorial 4. Start wiring at the end of the cable (near TS-10 and S4) consisting of a green, a blue, a yellow, and a violet wire.

- (✓) Connect the violet wire to terminal 2 of TS-10(DS).

- (✓) Connect the yellow wire to terminal 1 of TS-10(DS).

- (✓) Connect the green wire to terminal 5 of switch S4.(DS).

- (✓) Connect the blue wire to terminal 1 (see figure 10 for terminal numbering) of tube socket XV4(DS).

- (✓) Locate the two wires (Red and Violet), breaking out of WH-1 near TS-9.

- (✓) Connect the red wire to terminal 1 of TS-9(DS).

- (✓) Connect the violet wire to terminal 2 of TS-9(DS).

- (✓) Locate the other end of the cable consisting of a red, a green, a blue, and a yellow wire.

- (✓) Connect the green wire to terminal 5, section C front of bandswitch S2 (refer to Pictorial 4(DS)).

- (✓) Connect the red wire to terminal 1 of TS-15.(DS). The blue and yellow wires will be connected later.

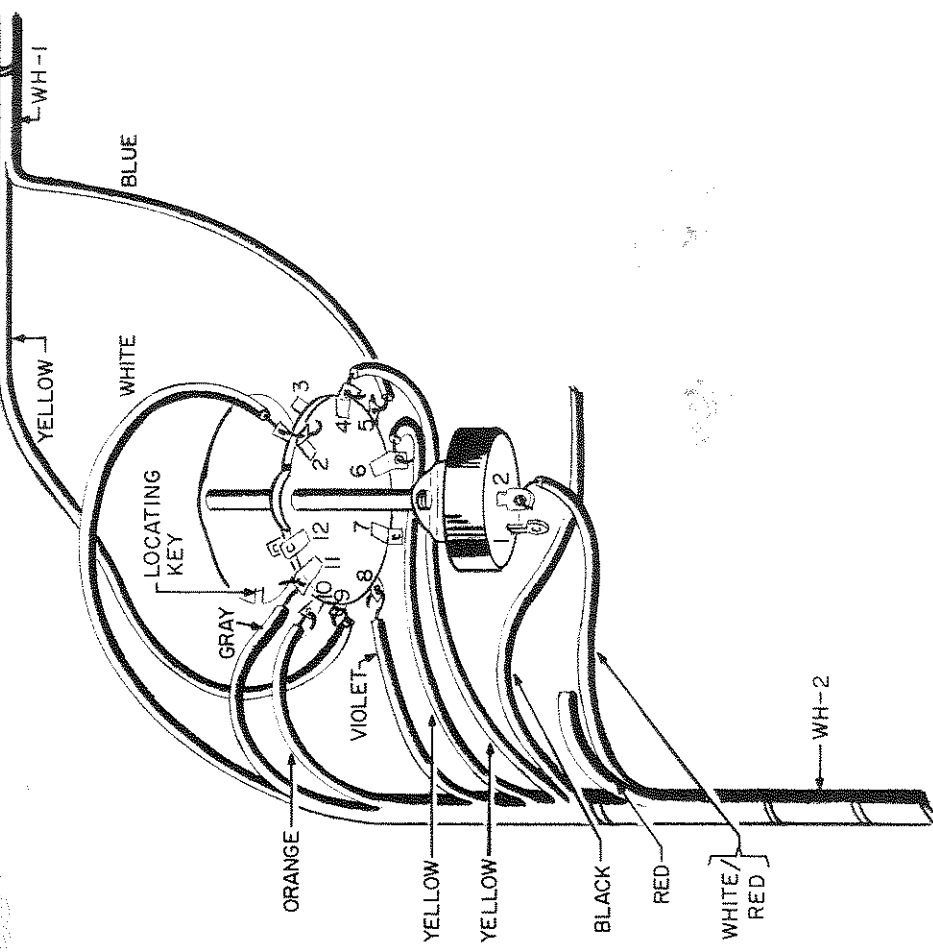

Figure 12. Wiring Function Switch S3.

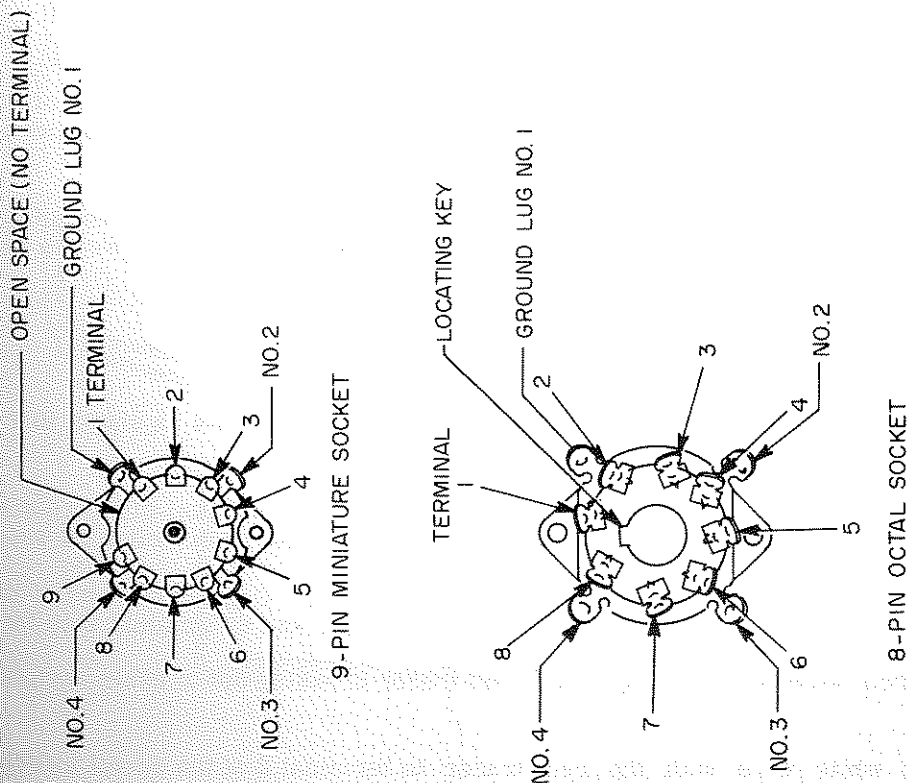

Figure 11. Numbering of Tube Socket Pins.

WIRING OF CABLE HARNESS WH-2 AND FUNCTION SWITCH S3

To facilitate wiring the function switch, the leads from cable harness WH-2 should be connected prior to mounting the switch. Locate the end of WH-2 consisting of a white, an orange, a gray, a violet, a black, and two yellow wires, refer to Figure 12, and proceed as follows:

- (✓) Connect the white wire to terminal 2 on both the front and rear of FUNCTION switch S3 wafer as shown in Figure 12, solder to both terminals.
- (✓) Connect the longer of the two yellow leads to terminal 4 on the rear of switch S3. (S-1)
- (✓) Connect the other yellow wire to terminal 6 on the rear of the switch S3. (S-1)
- (✓) Connect the violet wire to terminal 8 on the front of switch S3. (S-1)
- (✓) Connect the orange wire to terminal 10 on the front of switch S3. (S-1)
- (✓) Connect the gray wire to terminal 11 on the rear of switch S3. (S-1)
- (✓) Connect the blue wire from the cable harness WH-1 (at front of chassis) to terminal 5 on the front of switch S3. (S-1)
- (✓) Connect the yellow wire from the cable harness WH-1 to terminal 9 on the front of the switch S3. (S-1)

This completes the wiring of both cables (WH-1 and WH-2) to the front and rear of FUNCTION switch S3 wafer. Gently dress the leads to the switch out of the way so that the switch may be installed on the panel without pinching the leads or bending or breaking switch terminals.

Temporarily mount the switch in hole 50, with the locating key inserted in hole 60 in the chassis front flange. Secure with a palnut; finger tighten only, because this nut will have to be removed when the front panel is installed.

- (✓) Dress the rear cable along the chassis as shown in Pictorial 5.
- (✓) Cut a piece of red wire 3-3/4" long. Strip both ends 3/8". Connect one end of this wire to terminal 3 on the front of FUNCTION switch S3 wafer (S-1). Connect the other end to terminal 4 of TS-15 (DS).
- (✓) Cut a piece of black wire 4-1/2" long. Strip both ends 3/8". Connect one end of this wire to terminal 12 on both the front and rear of the wafer of FUNCTION switch S3. Solder both terminals.
- (✓) Connect the other end of this wire to terminal 4 of TS-4(DS). This completes the wiring of the FUNCTION switch S3.
- (✓) Connect the black wire from the rear cable to terminal 3 of TS-4 as shown in Pictorial 5. (DS)
- (✓) Connect the black wire from transformer T1 that runs parallel to the rear cable to terminal 1 of the on-off switch mounted on the rear of FUNCTION switch S3 wafer (DS).
- (✓) Cut a piece of black wire 3" long. Strip both ends 3/8". Connect one end of this wire to terminal 1 of the on-off switch (S-2). Connect the other end to terminal 1 of TS-4 (DS).
- (✓) Locate the red wire and white wire with red tracer breaking out of cable harness WH-2 near TS-15.
- (✓) Connect the white wire with the red tracer to terminal 2 of the on-off switch. (S-1).
- (✓) Connect the red wire to terminal 4 of TS-15 (DS).

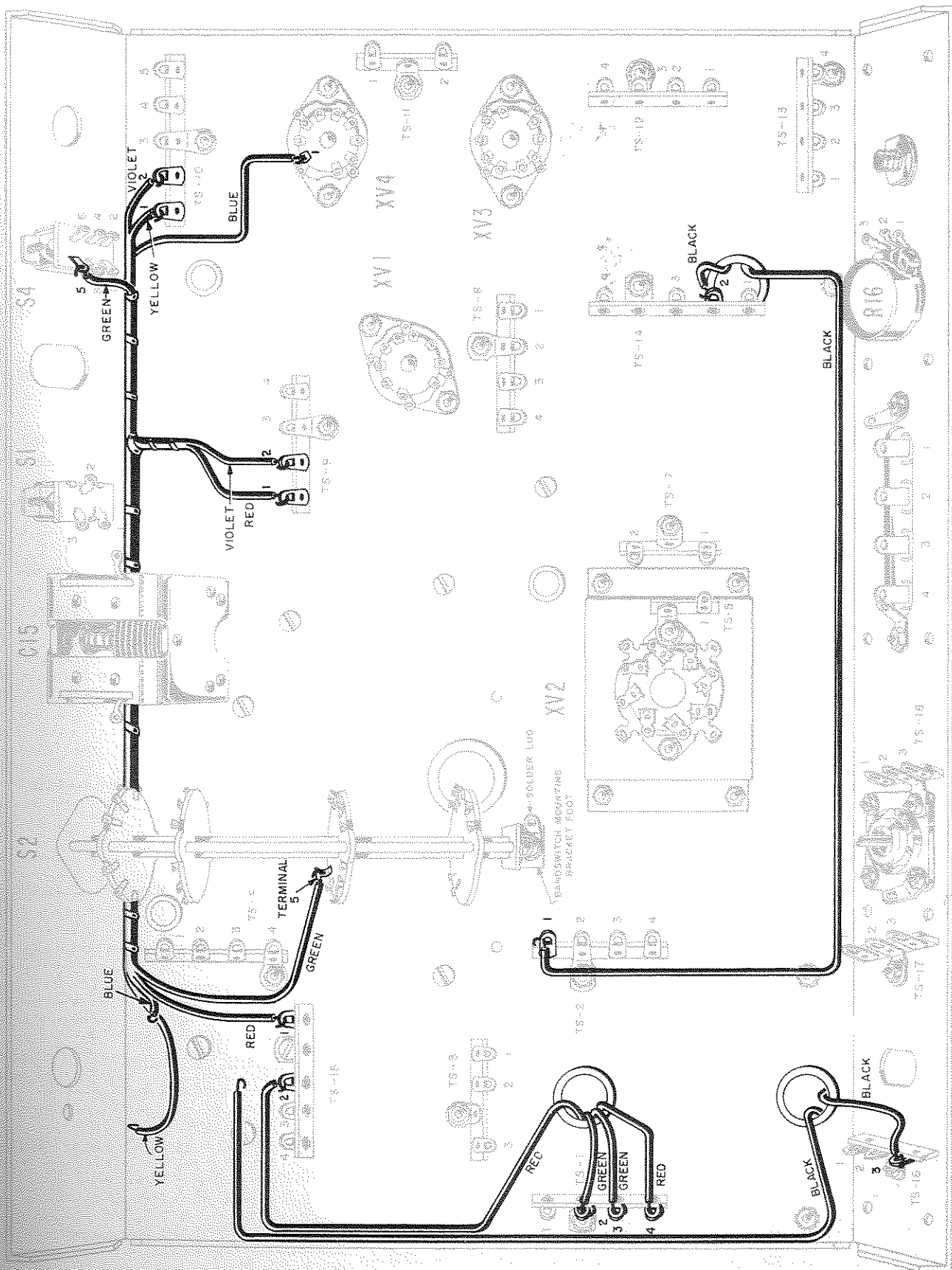

Pictorial 4. Installation of Front Cable Harness WH-1.

- (✓) Connect the single red wire breaking out of cable harness WH-2 (near TS-3) to terminal 3 of TS-3 (DS).
- (✓) Connect the brown wire breaking out of cable harness WH-2 (near TS-1) to terminal 3 of TS-1 (S-2).
- (✓) Locate the black wire and the white wire with the red tracer breaking out of cable harness WH-2 near TS-16. Connect the white wire with the red tracer to terminal 1 of TS-16 (DS).
- (✓) Connect the black wire to terminal 3 of TS-16 (DS).
- (✓) Connect the two gray wires breaking out of cable harness WH-2 (near TS-17), to terminal 3 of TS-2 (DS).
- (✓) Locate an orange wire breakout near TS-18. Connect this wire to terminal 1 of TS-18 (DS).
- (✓) Locate the two yellow wires and the white wire with a black tracer breaking out of cable harness WH-2 near the 4-connector board mounted on the rear flange of the chassis. Connect one of the yellow wires to terminal 1 of the 4-connector board (DS).
- (✓) Connect the other yellow wire to terminal 2 of the 4-connector board. (DS).
- (✓) Connect the white wire with the black tracer to terminal 3 of the 4-connector board. (DS).
- (✓) Connect the single violet wire breaking out of cable harness WH-2 near TS-7 to terminal 1 of TS-7 (DS).
- (✓) Connect the outer conductor of the orange shielded wire breaking out of cable harness WH-2 between TS-7 and the 4-connector board to ground terminal 1 of socket XV2 (DS).
- (✓) Connect the center conductor of this shielded wire to terminal 1 of TS-5 (DS).
- (✓) Locate the three wires (one orange and two brown wires) breaking out of cable harness WH-2 near TS-7. Connect the orange wire to terminal 8 of socket XV2 (DS).
- (✓) Connect the two brown wires to terminal 7 of socket XV2 (DS).
- (✓) Push the white wire breaking out of the cable near the three wire breakout through chassis hole 51. This wire is to be connected later.
- (✓) Locate the red and brown wires breaking out of cable harness WH-2 near TS-8. Connect the red wire to terminal 1 of TS-8 (DS).
- (✓) Connect the brown wire to terminal 5 of socket XV1 (DS).
- (✓) Beyond the brown wire and the red wire breakout mentioned in the preceding steps above, the cable terminates in two brown wires. Connect both of these brown wires to terminal 9 of socket XV3 (DS).
- (✓) Locate the three wires (red, violet, and gray) breaking out of cable harness WH-2 near TS-14. Connect the violet wire to terminal 1 of TS-14 (DS).
- (✓) Connect the red wire to terminal 2 of TS-14 (DS).
- (✓) Connect the gray wire to terminal 3 of TS-14 (DS).
- (✓) Install the microphone gain control R16 on the rear flange of the chassis using the cadmium palnut in hole 52 as shown in Pictorial 2.

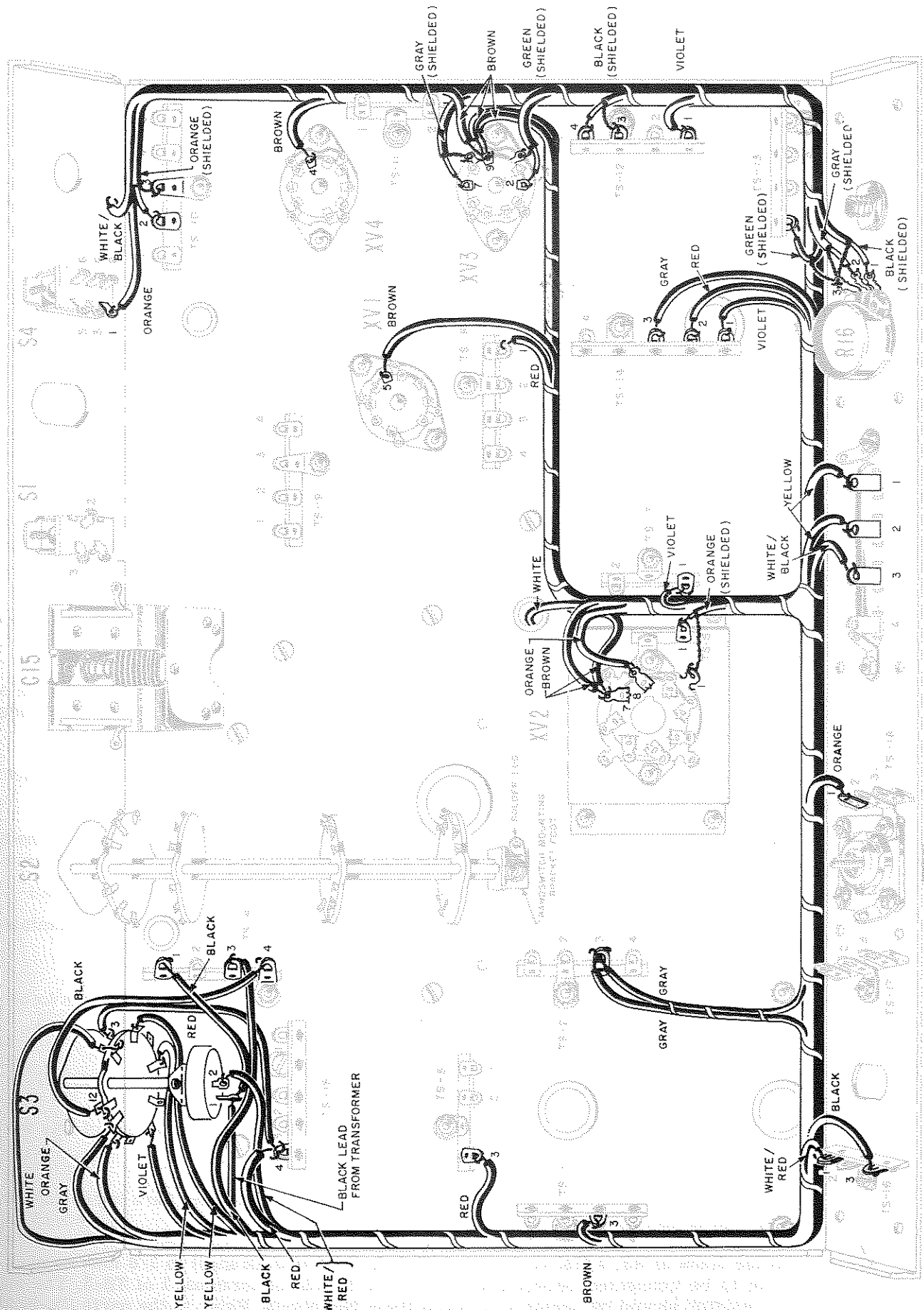

Pictorial 5. Installation of Rear Cable Harness WH-2.

- (✓) Install the microphone connector on the rear flange of the chassis in hole 53 as shown in Figure 13.
- (✓) Locate the green shielded wire breaking out of cable harness WH-2 near R16, as shown in Pictorial 5. Connect the outer conductor or shield braid to terminal 3 of R16 (DS) and the center conductor to terminal 1 of TS-13 (DS).
- (✓) Locate the gray shielded wire breaking out of cable harness WH-2 near R16. Connect the outer conductor or shield braid to terminal 3 of R16 (DS) and the center conductor to terminal 2 of R16 (S-1).
- (✓) Locate the black shielded wire breaking out of cable harness WH-2 near R16. Connect the outer conductor or shield braid to terminal 3 of R16 (S-3) and the center conductor to terminal 1 of R16 (S-1).
- (✓) A single violet wire breaks out of the cable near TS-12. Connect this violet wire to terminal 1 of TS-12 (DS).
- (✓) A black shielded wire breaks out of the cable near TS-12. Connect the outer conductor or shield braid to terminal 3 of TS-12 (S-1) and the center conductor to terminal 4 of TS-12 (DS).
- (✓) Locate the green shielded wire breaking out of the cable near TS-11. Connect the outer conductor or shield braid to ground lug No. 1 of socket XV3 (DS) and the center conductor to terminal 2 of socket XV3 (DS).
- (✓) Locate the single brown wire breaking out of the cable near TS-11. Connect this wire to terminal 9 of socket XV3 (S-3).
- (✓) Locate the gray shielded wire breaking out of the cable near TS-11. Connect the outer conductor or shield braid to ground lug No. 4 of socket XV3 (S-1) and the center conductor to terminal 7 of socket XV3 (S-1).
- (✓) Locate the single brown wire breaking out of WH-2 near socket XV4 and connect it to terminal 4 of socket XV4 (S-1).
- (✓) Locate the orange shielded wire at the end of the cable near TS-10. Connect the outer conductor or shield braid to terminal 3 of TS-10 (DS) and the center conductor to terminal 2 of TS-10 (DS).
- (✓) Locate the single orange wire at the end of WH-2 near TS-10 and connect to terminal 1 of S4 (DS).

The white wire with a black tracer at the end of the rear cable near TS-10 is to be connected later.

POWER SUPPLY COMPONENT WIRING (Refer to Pictorial 6)

- (✓) Cut a piece of No. 22 bare tinned wire 1-3/4 inches long. Connect one end of this wire to terminal 1 of TS-3 (DS).
- (✓) Cut a piece of yellow sleeving 1 inch long and slip over the above bare wire. Connect the other end of this wire to terminal 3 of TS-3 (DS).
- (✓) Cut the leads of R3, a 22Kohm-2 watt resistor (Red-Red-Orange) to 7/8 inch on each end. R3 is to be connected between terminal 1 of TS-15 and terminal 1 of TS-3. The body of the resistor should be centered between these two points. Refer to the parts illustrations in the back of the book for the correct resistor size.

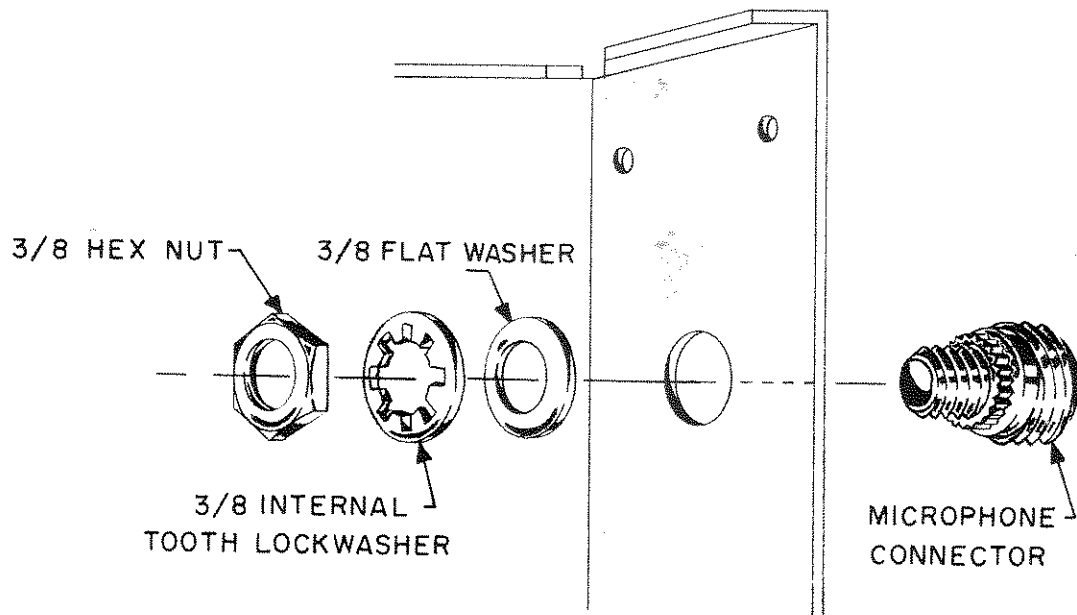

Figure 13. Microphone Connector Installation.

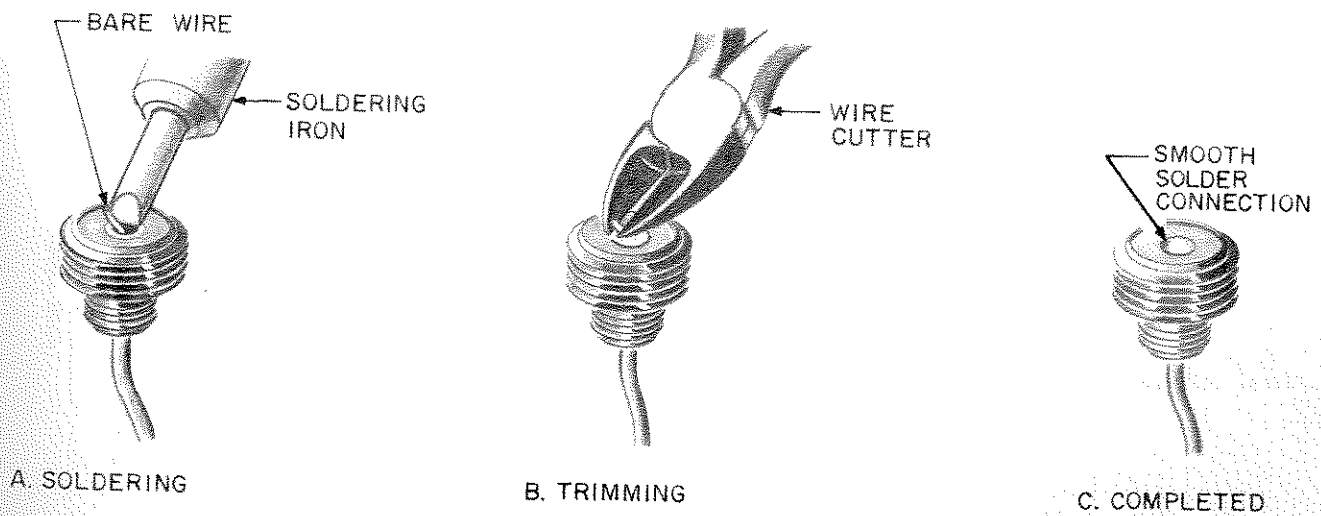
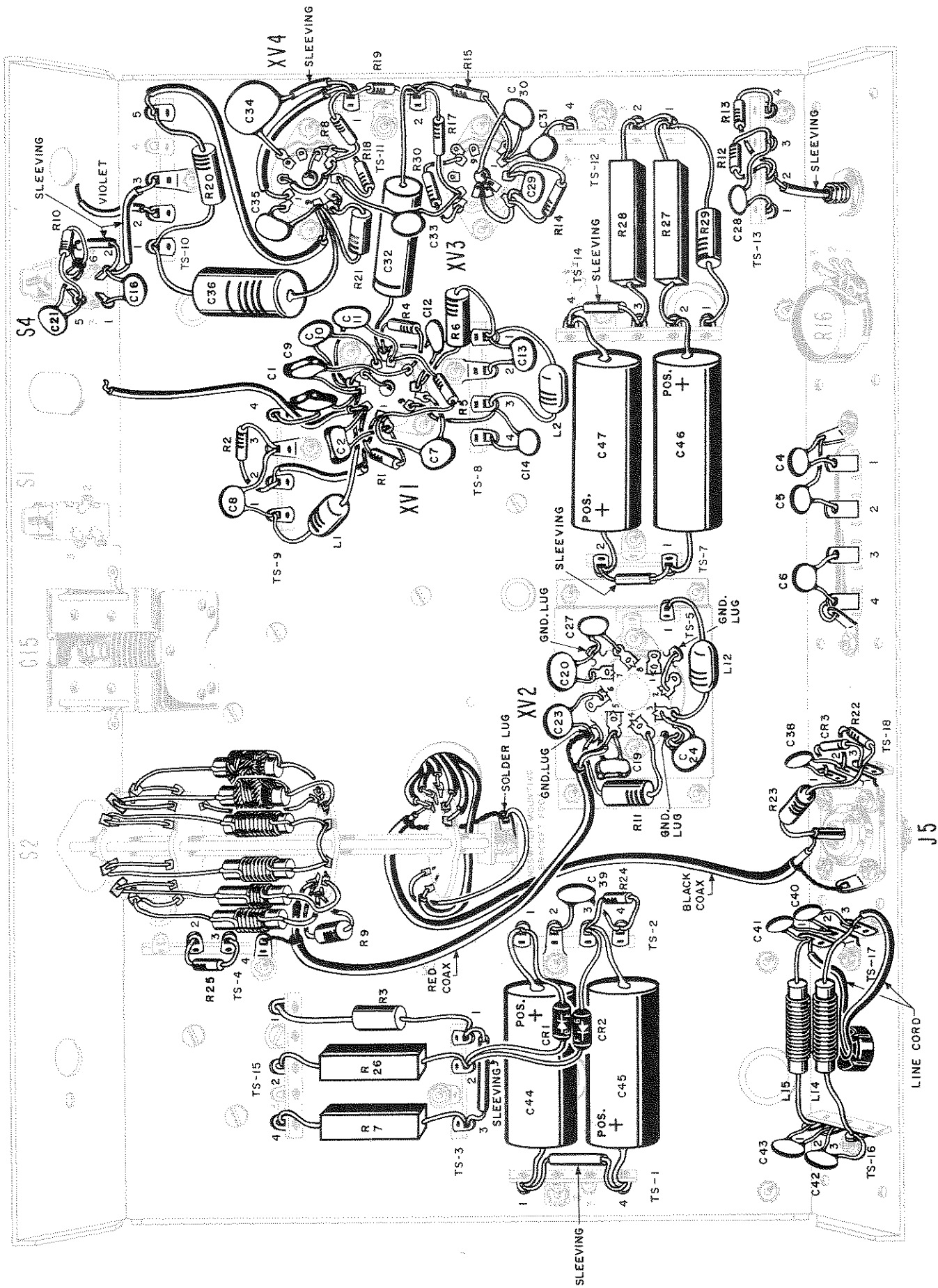

Figure 14. Soldering Microphone Connector.



Pictorial 6. Wiring of Components.

- (✓) Connect one end of R3 to terminal 1 of TS-15 (S-2).
- (✓) Connect the other end of R3 to terminal 1 of TS-3 (S-2).
- (✓) Cut the leads of R26 a 20 ohm 7-watt resistor (square body) to 1/2 inch on each end.
- (✓) Connect one end of R26 to terminal 2 of TS-15 (S-2).
- (✓) Connect the other end of R26 to terminal 2 of TS-3 (DS).
- (✓) Cut the leads of R7, a 2500 ohm 7-watt resistor (square body) to 1/2 inch, on each end.
- (✓) Connect one end of R7 to terminal 4 of TS-15 (S-3).
- (✓) Connect the other end of R7 to terminal 3 of TS-3 (S-3).
- (✓) Cut a piece of No. 22 bare tinned wire 1-3/4 inch long. Connect one end of this bare wire to terminal 1 of TS-1 (DS).
- (✓) Cut a piece of yellow sleeving 1 inch long and slip over the above bare wire. Connect the other end of this wire to terminal 4 of TS-1 (DS).
- (✓) Cut the leads of R24, a 1000 ohm 1/2 watt resistor (brown-black-red) to 5/8 inch, on each end. Connect one end of R24 to terminal 4 of TS-2 (DS).
- (✓) Connect the other end of R24 to terminal 3 of TS-2 (DS).
- (✓) Cut the leads of C39 a .005 MFD 500V ceramic disc capacitor to 5/8 inch on each end. Connect one end of C39 to terminal 4 of TS-2 (S-2).
- (✓) Connect the other end of C39 to terminal 2 of TS-2 (S-1).
- (✓) Cut the leads of C44, a 40 MFD-350 Volt Electrolytic Capacitor to 5/8 inch on each end. Connect the POSITIVE end of C44 to terminal 1 of TS-2 (DS).
- (✓) Connect the other end of C44 to terminal 1 of TS-1 (S-2).
- (✓) Cut the leads of C45, another 40 MFD-350 Volt Electrolytic Capacitor to 5/8 inch on each end. Connect the POSITIVE end of C45 to terminal 4 of TS-1 (S-3).
- (✓) Connect the other end of C45 to terminal 3 of TS-2 (DS).
- (✓) Connect the Cathode (F) end of CR1, a type F6 silicon diode, to terminal 1 of TS-2(S-3). (Do not shorten leads). (Clips or long nose pliers should be used as a heat sink when soldering, see Figure 5).
- (✓) Connect the anode (6) end of CR1 to terminal 2 of TS-3 (DS). (Do not shorten leads).
- (✓) Connect the Cathode (F) end of CR2, a second Type F6 silicon diode, to terminal 3 of TS-2. (Do not shorten leads). (S-5) (Use heat sink).
- (✓) Connect the anode (6) end of CR2 to terminal 2 of TS-3. Do not shorten leads. (S-3) (Use heat sink).

NOTE

Dress the diodes as shown in Pictorial 6.

(✓) Cut a piece of No. 22 bare tinned wire 1-1/2 inch long. Connect one end of this wire to terminal 1 of TS-7 (DS).

- (✓) Cut a piece of yellow sleeving 3/4 inch long and slip this over the above bare wire. Connect the other end of the wire to terminal 2 of TS-7 (DS).
- (✓) Cut a piece of No. 22 bare tinned wire 1-1/4 inch long. Connect one end of this wire to terminal 3 of TS-14 (DS).
- (✓) Cut a piece of yellow sleeving 1/2 inch long and slip over the above bare wire. Connect the other end of the wire to terminal 4 of TS-14 (DS).
- (✓) Cut the leads of R29, a 1000 ohm-2-watt resistor (brown-black-red) to 1 inch on each end. Connect one end of R29 to terminal 1 of TS-14 (S-2).
- (✓) Connect the other end of R29 to terminal 1 of TS-12 (DS).
- (✓) Cut a piece of No. 22 bare tinned wire 1 inch long. Connect one end of this wire to terminal 1 of TS-12 (DS) and the other end to terminal 2 of TS-12 (DS) as shown in Pictorial 6.
- (✓) Cut the leads of C47, a 40 MFD-350 Volt Electrolytic Capacitor to 5/8 inch on each end.
- (✓) Connect the POSITIVE end of C47 to terminal 2 of TS-7 (S-2).
- (✓) Connect the other end of C47 to terminal 4 of TS-14 (S-2).
- (✓) Cut the leads of C46 another 40 MFD-350 volt electrolytic capacitor to 5/8 inch on each end. Connect the POSITIVE end of C46 to terminal 2 of TS-14 (DS).
- (✓) Connect the other end of C46 to terminal 1 of TS-7 (S-3).
- (✓) Cut the leads of R28, the 10K ohm 10-watt resistor to 3/4 inch on each end. Connect one end of R28 to terminal 3 of TS-14 (S-3).
- (✓) Connect the other end of R28 to terminal 2 of TS-12 (S-2).
- (✓) Cut the leads of R27 another 10K ohm 10 watt resistor to 3/4 inch on each end. Connect one end of R27 to terminal 2 of TS-14 (S-4).
- (✓) Connect the other end of R27 to terminal 1 of TS-12 (S-4).

This completes the wiring of all of the power supply components.

FINAL WIRING OF 4-CONNECTOR BOARD

- (✓) Cut the leads of C4, C5, and C6 three .001 MFD, 1KV ceramic disc capacitors to 5/8 inch on each end.
- (✓) Connect one end of C6 through terminal 4 of the 4-connector board through the solder lug bent against terminal 4. Solder the lead of C6 to terminal 4 and the solder lug.
- (✓) Connect the other end of C6 to terminal 3 of the 4-connector board (S-2).
- (✓) Connect one end of C5 a .001 MFD, 1 KV ceramic disc capacitor to terminal 2 of the 4-connector board (S-2).
- (✓) Connect the other end of C5 to the grounding lug near terminal 1. (DS).
- (✓) Connect one end of C4 a .001 MFD, 1KV ceramic disc capacitor to terminal 1 of the 4-connector board (S-2).
- (✓) Connect the other end of C4 to the grounding lug near terminal 1 (S-2).

This completes the wiring of the 4-connector board.

AUDIO CIRCUIT COMPONENT WIRING

- (✓) Cut the leads of R13, a 1 megohm-1/2-watt resistor (brown-black-green), to 7/8 inch on each end. Connect one end of R13 to terminal 2 of TS-13 (DS).
- (✓) Connect the other end of R13 to terminal 4 of TS-13 (S-1).
- (✓) Cut the leads of R12, a 4700 ohm-1/2-watt resistor (yellow-violet-red), to 5/8 inch on each end. Connect one end of R12 to terminal 2 of TS-13 (DS).
- (✓) Connect the other end of R12 to terminal 3 of TS-13 (DS).
- (✓) Cut the leads of C28, a .001 MFD 500 volt disc capacitor, to 3/4 inch on each end. Connect one end of C28 to terminal 3 of TS-13 (S-2).
- (✓) Connect the other end of C28 to terminal 1 of TS-13 (S-2).
- (✓) Cut a piece of No. 22 bare tinned wire 1-3/4 inch long. Connect one end of this wire to terminal 2 of TS-13 (S-3).
- (✓) Cut a piece of yellow sleeving 1 inch long and slip over the end of the bare wire. Push the free end of the bare wire through the center terminal of the microphone connector. The wire should extend about 1/4 inch beyond the connector, bend this wire to the side as shown in Figure 14.
- (✓) Solder the wire to the center terminal of the microphone connector. Care should be taken to apply only enough solder to make a firm connection between the wire and the terminal.
- (✓) Cut the excessive wire off the connection. The completed connection will appear as a smooth button of solder as shown in Figure 14C.
- (✓) Cut the leads of C31, a .001 MFD 500V disc capacitor, to 5/8 inch on each end. Connect one end of this capacitor to terminal 4 of TS-12 (S-2).
- (✓) Connect the other end of C31 to terminal 1 of socket XV3 (DS).
- (✓) Cut the leads of R15, a 470K ohm 1/2-watt resistor (yellow-violet-yellow), to 3/4 inch on each end. Connect one end of R15 to terminal 1 of socket XV3 (DS).
- (✓) Connect the other end of R15 to terminal 2 of TS-11 (DS).
- (✓) Cut the leads of C30, a .001 MFD 1 KV disc capacitor, to 3/8 inch on each end. Connect one end of C30 to terminal 1 of socket XV3 (S-3).
- (✓) Connect the other end of C30 to the center post of socket XV3 (DS).
- (✓) Bend terminals 3, 4, and 5 of socket XV3 against the center post of socket XV3 as shown in Figure 15 and Pictorial 6.
- (✓) Cut a piece of No. 22 bare tinned wire 1 inch long. Connect one end of this wire to ground lug No. 2 on socket XV3 (DS).
- (✓) Connect the other end of this bare wire to the center post of socket XV3. Solder the three terminals 3, 4, and 5 and the wire to the center post.
- (✓) Cut the leads of C29, a 100 MMF 500 volt ceramic disc capacitor, to 1/2 inch on each end. Connect one end of C29 to ground lug No. 2 of socket XV3 (DS).
- (✓) Connect the other end of C29 to terminal 2 of socket XV3 (DS).

- (✓) Cut the leads of R14, a 2.2 megohm 1/2-watt resistor (red-red-green), to 1/2 inch on each end. Connect one end of R14 to terminal 2 of socket XV3 (S-3).
- (✓) Connect the other end of R14 to ground terminal 2 of socket XV3 (S-3).
- (✓) Cut the leads of R30, a 100 ohm 1/2-watt resistor (brown-black-brown), to 5/8 inch on each end. Connect one end of R30 to terminal 8 of socket XV3 (S-1).
- (✓) Connect the other end of R30 to ground lug 3 of socket XV3 (S-1).
- (✓) Cut the leads of R17, a 470K ohm 1/2-watt resistor (yellow-violet-yellow), to 3/4 inch on each end. Connect one end of R17 to terminal 2 of TS-11 (DS).
- (✓) Connect the other end of R17 to terminal 6 of socket XV3 (DS).
- (✓) Cut the leads of C32, a 0.1 MFD 600 volt molded paper capacitor, to 7/8 inch on each end. Connect one end of C32 to terminal 2 of TS-11 (DS).
- (✓) Connect the other end of C32 to ground lug 3 of socket XV1 (DS).
- (✓) Cut the leads of C33, a .001 MFD ceramic disc capacitor, to 7/8 inch on each end. Connect one end of this capacitor to terminal 6 of socket XV3 (S-2).
- (✓) Connect the other end of C33 to terminal 7 of socket XV4 (DS).
- (✓) Cut the leads of R19, a 470K ohm 1/2 watt resistor (yellow-violet-yellow), to 5/8 inch on each end. Connect one end of R19 to terminal 2 of TS-11 (S-4).
- (✓) Connect the other end of R19 to terminal 1 of TS-11 (DS).
- (✓) Cut the leads of R18, a 10 megohm 1/2-watt resistor (brown-black-blue), to 5/8 inch on each end. Connect one end of R18 to terminal 7 of socket XV4 (S-2).
- (✓) Connect the other end of R18 to ground lug 3 on socket XV4 (DS).
- (✓) Cut a piece of No. 22 bare tinned wire 1 inch long. Pass one end of this bare wire through terminal 5 of socket XV4 and connect to ground lug 3 of socket XV4 (S-2).
- (✓) Connect the other end of this wire to the center post of socket XV4 (S-1).
- (✓) Solder terminal 5 on socket XV4.
- (✓) Cut a piece of No. 22 bare tinned wire 1-1/4 inches long. Connect one end of this bare wire to terminal 2 of socket XV4 (S-1).
- (✓) Cut a piece of yellow sleeving 5/8 inch long and slip over the bare wire. Connect the other end of this wire to terminal 6 of socket XV4 (DS).
- (✓) Cut the leads of R8, a 1 megohm 1/2 watt resistor (brown-black-green), to 1/2 inch on each end. Connect one end of R8 to terminal 1 of TS-11 (DS).
- (✓) Connect the other end of R8 to terminal 6 of socket XV4 (S-2).
- (✓) Cut a piece of blue wire 2-1/2 inches long. Strip both ends 3/8 inch. Connect one end to terminal 1 of socket XV4 (S-2).
- (✓) Connect the free end of the blue wire to terminal 1 of TS-11 (DS).
- (✓) Cut the leads of C34, a .01MFD1400 V ceramic disc capacitor, to 1-1/4 inches on one end and to 1/2 inch on the other end. Connect the 1/2 inch lead to ground lug 2 of socket XV4 (S-1).

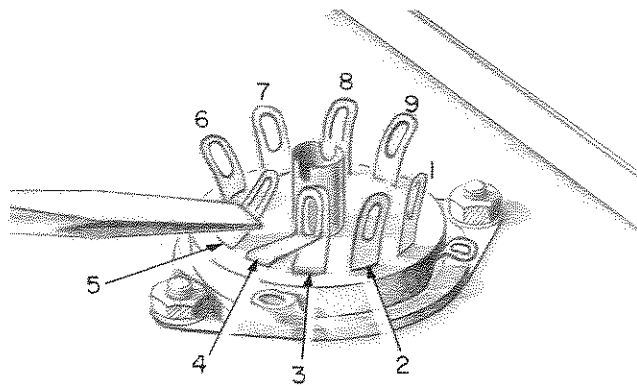

A. BENDING TUBE SOCKET TERMINALS

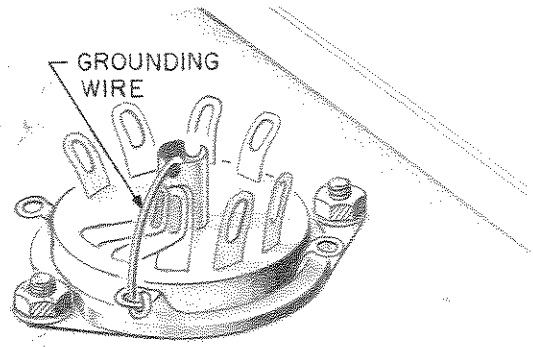

B. CONNECTING TUBE SOCKET GROUND LEAD

Figure 15. Grounding Terminals 3, 4 and 5 of Tube Socket XV3.

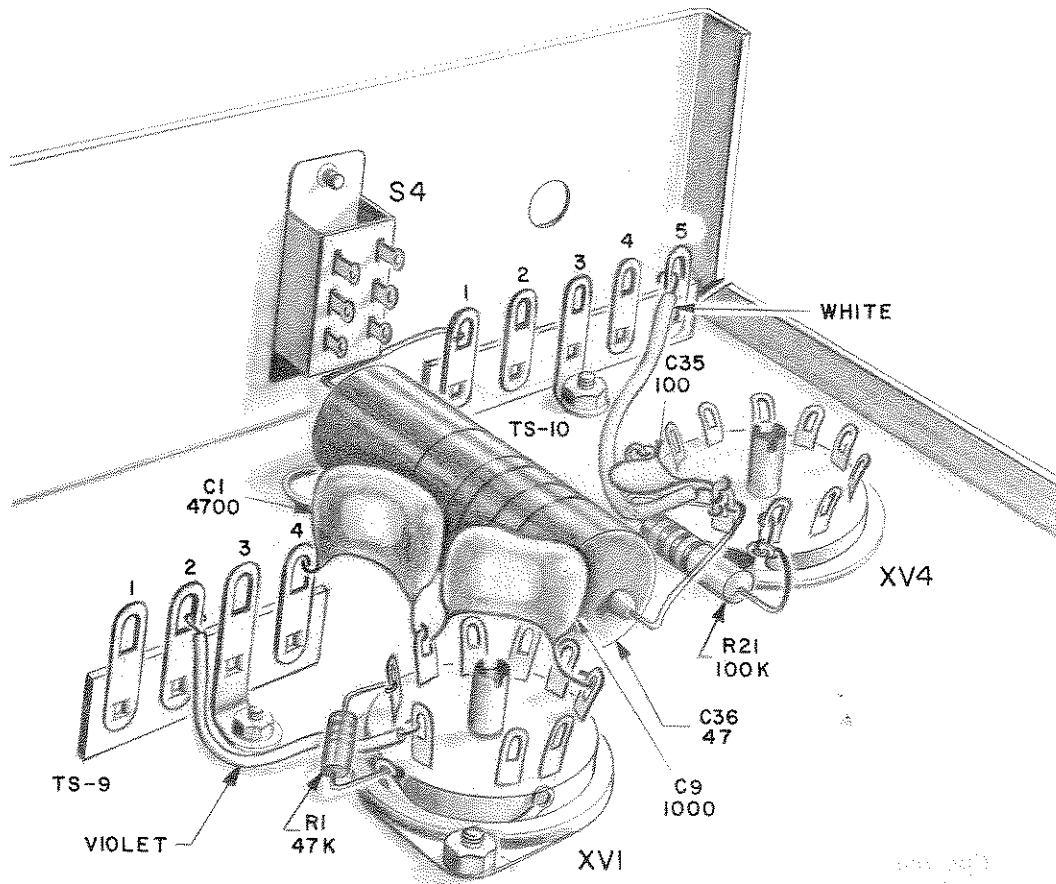

Figure 16. Detail Wiring of Sockets XVI and XV4.

- (✓) Cut a 7/8 inch long piece of yellow sleeving and slip over the 1-1/4 inch lead of C34. Connect this 1-1/4 inch lead to terminal 1 of TS-11 (S-4).
- (✓) Cut the leads of R21, a 100K ohm 1-watt resistor (brown-black-yellow), to 3/4 inch on each end. Pass one lead of R21 through ground lug No. 4 of socket XV4 and connect to terminal 8 of socket XV4 (solder both lug No. 4 and terminal 8).
- (✓) Connect the other lead of R21 to terminal 9 of socket XV4 (DS) (see Figure 16 and Pictorial 6).
- (✓) Cut the leads of C35, a 100 MMF, 1KV ceramic disc capacitor, to 1/2 inch on each end. Connect one lead of C35 to ground lug No. 1 of socket XV4 (S-1).
- (✓) Connect the other lead of C35 to terminal 9 of socket XV4 (DS).
- (✓) Cut a piece of white wire 3 inches long. Strip both ends 3/8 inch. Connect one end of this wire to terminal 5 of TS-10 (DS).
- (✓) Connect the other end of the white wire to terminal 9 of socket XV4 (DS).
- (✓) Cut the leads of R20, and 18K ohm 2 watt resistor (brown-gray-orange), to 7/8 inch on each end. Connect one lead of R20 to terminal 1 of TS-10 (DS).
- (✓) Connect the other lead of R20 to terminal 5 of TS-10 (S-2).
- (✓) Cut the leads of C36, a .47 MFD 400V capacitor, to 3/4 inch on one end and to 1-3/8 inch on the other end. Connect the 3/4 inch lead to terminal 1 of TS-10 (S-3).
- (✓) Connect the 1-3/8 inch lead to terminal 9 of socket XV4 (S-4).
- (✓) Cut a piece of violet wire 2 inches long. Strip both ends 3/8 inch. Connect one end of this wire to terminal 2 of TS-10 (S-3). The other end will be connected to the phone jack later.
- (✓) Cut a piece of No. 22 bare tinned wire 1-1/2 inches long. Connect one end to terminal 3 of TS-10 (S-2).
- (✓) Cut a piece of yellow sleeving 3/4 inch long and slip over the bare wire. Connect this end of the wire to terminal 2 of S4 (DS).
- (✓) Cut a piece of No. 22 bare tinned wire 1-1/8 inches long. Connect one end of this wire to terminal 2 of S4 (DS).
- (✓) Cut a piece of yellow sleeving 3/8 inch long and slip over the bare wire. Connect this end of the wire to terminal 6 of S4 (DS).
- (✓) Cut the leads of C16, a .002 MFD 500V ceramic disc capacitor, to 1/2 inch on each end. Connect one lead of C16 to terminal 2 of S4 (S-3).
- (✓) Connect the other lead of C16 to terminal 1 of S4 (S-2).
- (✓) Cut the leads of C21, a .002 MFD 500V ceramic disc capacitor to 1/2 inch on each end. Connect one lead of C21 to terminal 5 of S4 (DS).
- (✓) Connect the other lead of C21 to terminal 6 of S4 (DS).
- (✓) Cut the leads of R10, a 4700 ohm, 1/2 watt resistor (yellow-violet-red), to 1/2 inch on each end. Connect one lead of R10 to terminal 5 of S4 (S-3).
- (✓) Connect the other lead of R10 to terminal 6 of S4 (DS).

This completes the wiring of the audio circuits.

WIRING OF OSCILLATOR AND BUFFER CIRCUIT

- (✓) Cut the leads of C7, a .01 MFD 500V ceramic disc capacitor, to 1/2 inch on each end. Connect one lead of C7 to ground lug No. 4 of socket XV1 (S-1).
- (✓) Connect the other lead of C7 to terminal 1 of socket XV1 (DS).
- (✓) Cut the leads of R6, a 22Kohm 2-watt resistor (red-red-orange), to 3/4 inch on each end. Connect one lead of R6 to terminal 1 of TS-8 (DS).
- (✓) Connect the other lead of R6 to terminal 8 of socket XV1, as shown in Pictorial 6, (DS).
- (✓) Cut the leads of C13, a .005 MFD 500V ceramic disc capacitor, to 1/2 inch on each end. Connect one lead of C13 to terminal 1 of TS-8 (DS).
- (✓) Connect the other lead of C13 to terminal 2 of TS-8 (S-1).
- (✓) Cut the leads of L2, a millihenry choke (brown-black-red), to 1/2 inch on each end. Connect one lead of L2 to terminal 1 of TS-8 (S-4).
- (✓) Connect the other lead of L2 to terminal 3 of TS-8 (DS).
- (✓) Cut the leads of C14, a .001 MFD 500V ceramic disc capacitor, to 3/8 inch on each end. Connect one lead of C14 to terminal 3 of TS-8 (DS).
- (✓) Connect the other lead of C14 to terminal 4 of TS-8 (DS).
- (✓) Cut a piece of No. 22 bare tinned wire 1-1/4 inches long. Connect one end of this wire to terminal 9 of socket XV1 (S-1).
- (✓) Cut a piece of yellow sleeving 5/8 inch long and slip over the end of the bare wire. Connect this end of the wire to terminal 3 of TS-8 (S-3).
- (✓) Cut the leads of R4, a 100K ohm 1/2 watt resistor (brown-black-yellow), to 1/2 inch on each end. Connect one lead of R4 to ground lug No. 3 of socket XV1 (DS).
- (✓) Connect the other lead of R4 to terminal 7 of socket XV1 (DS).
- (✓) Cut the leads of C12, a .001⁵ MFD 1 KV ceramic disc capacitor, to 1/2 inch on each end. Connect one lead of C12 to ground lug No. 3 of socket XV1 (S-3).
- (✓) Cut a 1/4 inch piece of yellow sleeving and slip over the other lead of C12 and connect this lead to terminal 8 of socket XV1 (S-2).
- (✓) Cut the leads of C11, a .005 MFD 500V ceramic disc capacitor, to 1/2 inch on each end. Connect one lead of C11 to ground lug No. 2 of socket XV1 (DS).
- (✓) Connect the other lead of C11 to terminal 6 of socket XV1 (DS).
- (✓) Cut the leads of C10, a .005 MFD 500V ceramic disc capacitor to 1/2 inch on each end. Connect one lead of C10 to ground lug No. 2 of socket XV1 (DS).
- (✓) Connect the other lead of C10 to terminal 5 of socket XV1 (S-2).
- (✓) Cut a piece of No. 22 bare tinned wire 1 inch long. Pass this wire through terminal 4 of socket XV1 and connect to ground lug No. 2 of socket XV1 (S-3).
- (✓) Connect the other end of this wire to the center post of socket XV1 (S-1). Also, solder the other end to terminal 4.
- (✓) Cut the leads of L1, a 2.5 millihenry choke (red-green-red), to 3/4 inch on each end.

- (✓) Connect one lead of L1 to terminal 3 of socket XV1 as shown in Pictorial 6 (DS).
- (✓) Connect the other lead of L1 to terminal 1 of TS-9 (DS).
- (✓) Cut the leads of C9, a 1000 MMF duramica capacitor (capacitor with the glossy finish) to 1/2 inch on each end. Connect one lead of C9 to terminal 7 of socket XV1, as shown in Figure 16, (S-2).
- (✓) Connect the other lead of C9 to terminal 3 of socket XV1 (DS).
- (✓) Cut the leads of C1, a 4700 MMF duramica capacitor (glossy finish), to 1/2 inch on each end. Connect one lead of C1 to terminal 3 of socket XV1 (S-3).
- (✓) Connect the other lead of C1 to terminal 4 of TS-9 as shown in Figure 16. (DS).
- (✓) Cut a piece of violet wire 2 inches long. Strip both ends 3/8 inch. Connect one end of this wire to terminal 2 of TS-9 (DS).
- (✓) Connect the other end of this wire to terminal 1 of socket XV1 (DS).
- (✓) Cut the leads of R1, a 47K ohm 1/2 watt resistor (yellow-violet-orange), to 1/2 inch on each end. Connect one lead of R1 to terminal 2 of socket XV1 (DS).
- (✓) Connect the other lead of R1 to ground lug No. 1 of socket XV1 (DS).
- (✓) Cut the leads of R5, a 470 ohm 1/2 watt resistor (yellow-violet-brown), to 3/4 inch on each end. Connect one lead of R5 to terminal 6 of socket XV1 as shown in Pictorial 6. (S-2).
- (✓) Connect the other lead of R5 to terminal 1 of socket XV1 (S-3).
- (✓) Cut the leads of C2, a 22 MMF duramica capacitor (glossy finish), to 1/2 inch on each end. Connect one lead of C2 to terminal 2 of socket XV1 (DS).
- (✓) Connect the other lead of C2 to ground lug No. 1 of socket XV1 (S-2).
- (✓) Cut a piece of green wire 3 inches long. Connect one end of this wire to terminal 2 of socket XV1 (S-3). The other end will be connected later.
- (✓) Cut the leads of R2, a 47K ohm 1/2 watt resistor (yellow-violet-orange) to 1/2 inch on each end. Connect one lead of R2 to terminal 3 of TS-9 (DS).
- (✓) Connect the other lead of R2 to terminal 2 of TS-9 (S-3).
- (✓) Cut the leads of C8, a .005 MFD 1KV ceramic disc capacitor, to 1/2 inch on each end. Connect one lead of C8 to terminal 3 of TS-9 (DS).
- (✓) Connect the other lead of C8 to terminal 1 of TS-9 (S-3).
- (✓) Cut a piece of white wire with a black tracer 3-1/2 inches long and strip 3/8 inch on both ends. Connect one end of this wire to terminal 4 of TS-8 (DS).
- (✓) Pass the other end of this wire through hole 51 and connect to terminal 2 of TS-6 as shown in Pictorials 3 and 6 (S-1).
- (✓) Cut a piece of white wire with a black tracer 4-1/2 inches and strip 3/8 inch on both ends. Connect one end of this wire to terminal 4 of TS-8 as shown in Pictorial 6. (S-3).
- (✓) Connect the other end of this lead to terminal 1 of the drive capacitor (S-1).
- (✓) Cut a piece of yellow wire 2-1/2 inches long. Strip both ends 3/8 inch. Connect one end of this wire to terminal 4 of TS-9 as shown in Pictorial 7 (S-2).

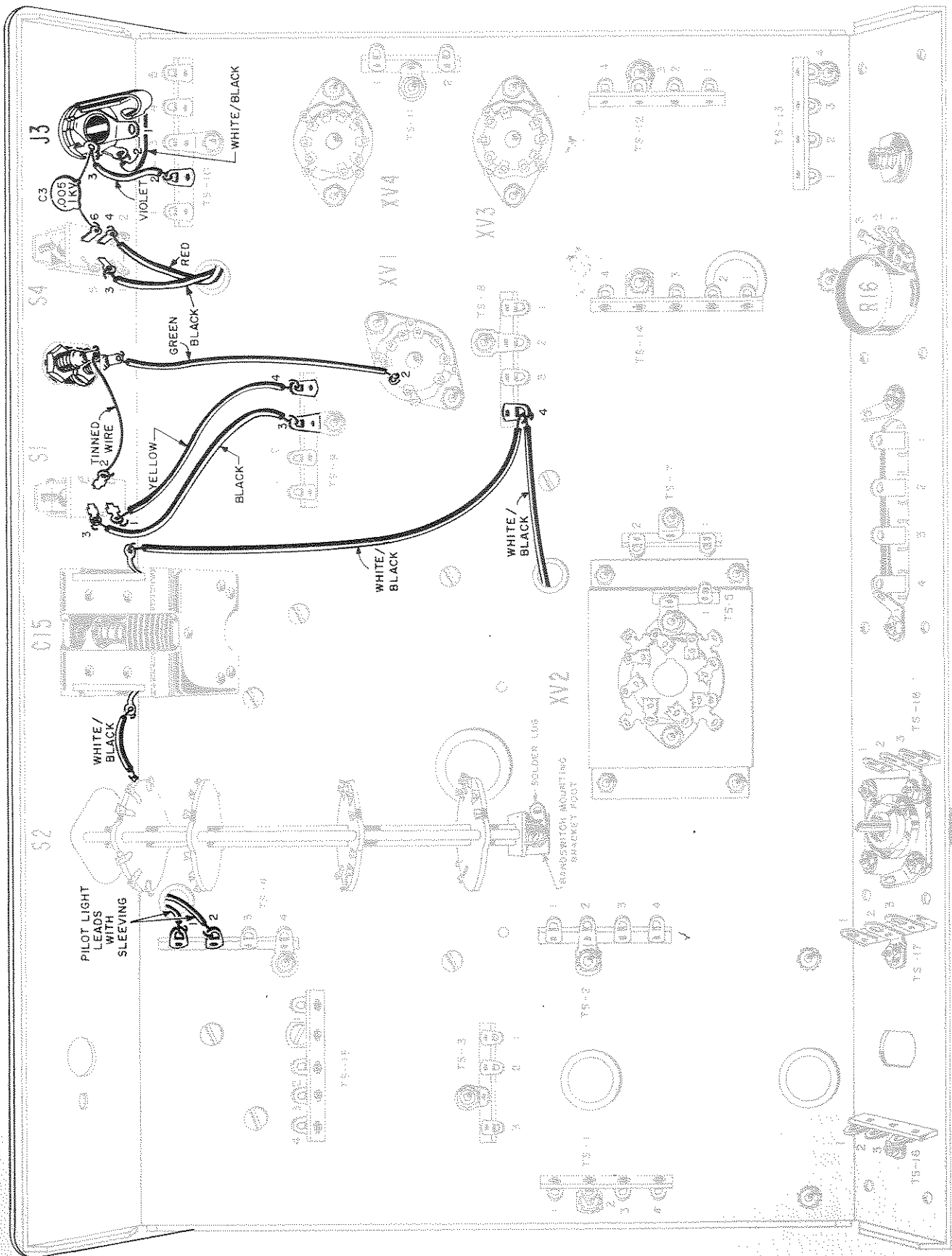

Pictorial 7. Wiring Components of Front Panel.

- (✓) Connect the other end of this yellow wire to terminal 1 of S1 (S-1).
- (✓) Cut a piece of black wire 2-1/2 inches long and strip both ends 3/8 inch. Connect one end of this black wire to terminal 3 of TS-9 as shown in Pictorial 7 (S-3).
- (✓) Connect the other end of this wire to terminal 3 of S1 (S-1).
- (✓) Cut the leads of ^{R6} R6, a 22K ohm 2 watt resistor (red-red-orange), to 3/4 inch on each end. Connect one lead of R6 to terminal 4 of socket XV2 as shown in Pictorial 6 (S-1).
- (✓) Connect the other lead of ^{R6} R6 to ground lug 3 of socket XV2 (DS).
- (✓) Cut the leads of C24, a .005 MFD 500V ceramic disc capacitor, to 1/2 inch on each end. Connect one lead of C24 to terminal 3 of socket XV2 (DS).
- (✓) Connect the other lead of C24 to ground lug No. 2 of socket XV2 (S-1).
- (✓) Cut a piece of No. 22 bare tinned wire 1 inch long. Connect one end to ground lug No. 1 of socket XV2 (S-2).
- (✓) Connect the other end of this wire to terminal 2 of socket XV2 (S-1).
- (✓) Cut the leads of L12, a 330 microhenry choke (orange-orange-brown), to 3/4 inch on each end. Connect one lead of L12 to terminal 1 of TS-5 (S-2).
- (✓) Connect the other lead of L12 to terminal 3 of socket XV2 (S-2).
- (✓) Cut the leads of C27, a .001 MFD 500V ceramic disc capacitor, to 1/2 inch on each end. Connect one lead of C27 to ground lug No. 4 of socket XV2 (DS).
- (✓) Connect the other lead of C27 to terminal 8 of socket XV2 (S-2).
- (✓) Cut the leads of C20, a .005 MFD 500V ceramic disc capacitor, to 1/2 inch on each end. Connect one lead of C20 to ground lug No. 4 of socket XV2 (S-2).
- (✓) Connect the other lead of C20 to terminal 7 of socket XV2 (S-3).
- (✓) Cut the leads of C23, a .005 MFD 1 KV ceramic disc capacitor, to 1/2 inch on each end. Connect one lead of C23 to ground lug No. 3 of socket XV2 (DS).
- (✓) Connect the other lead of C23 to terminal 6 of socket XV2 (S-1).
- (✓) Cut the leads of C19, a 33 MMF duramica capacitor (brown glossy finish), to 1/2 inch on each end. Connect one lead of C19 to ground lug No. 3 of socket XV2 (DS).
- (✓) Connect the other lead of C19 in the bottom hole of terminal 5 of socket XV2 solder the bottom hole only.
- () Cut a piece of No. 22 bare tinned wire 5 inches long. Pass one end of this wire through terminal 9, section C, of the bandswitch S2 and connect it to terminal 9 on the front of section B, refer to Figure 17 (S-1). Also solder terminal 9 of section C of bandswitch S2.
- () Slip a 1/4 inch piece of sleeving over the wire.
- () Pass the wire over the top of terminals 10, 11, 12, 1, 2, and 3 respectively, with the sleeving placed between terminals 12 and 1 to prevent shorting the terminals to the switch support rod. Connect the end of the wire to terminal 3 (DS).

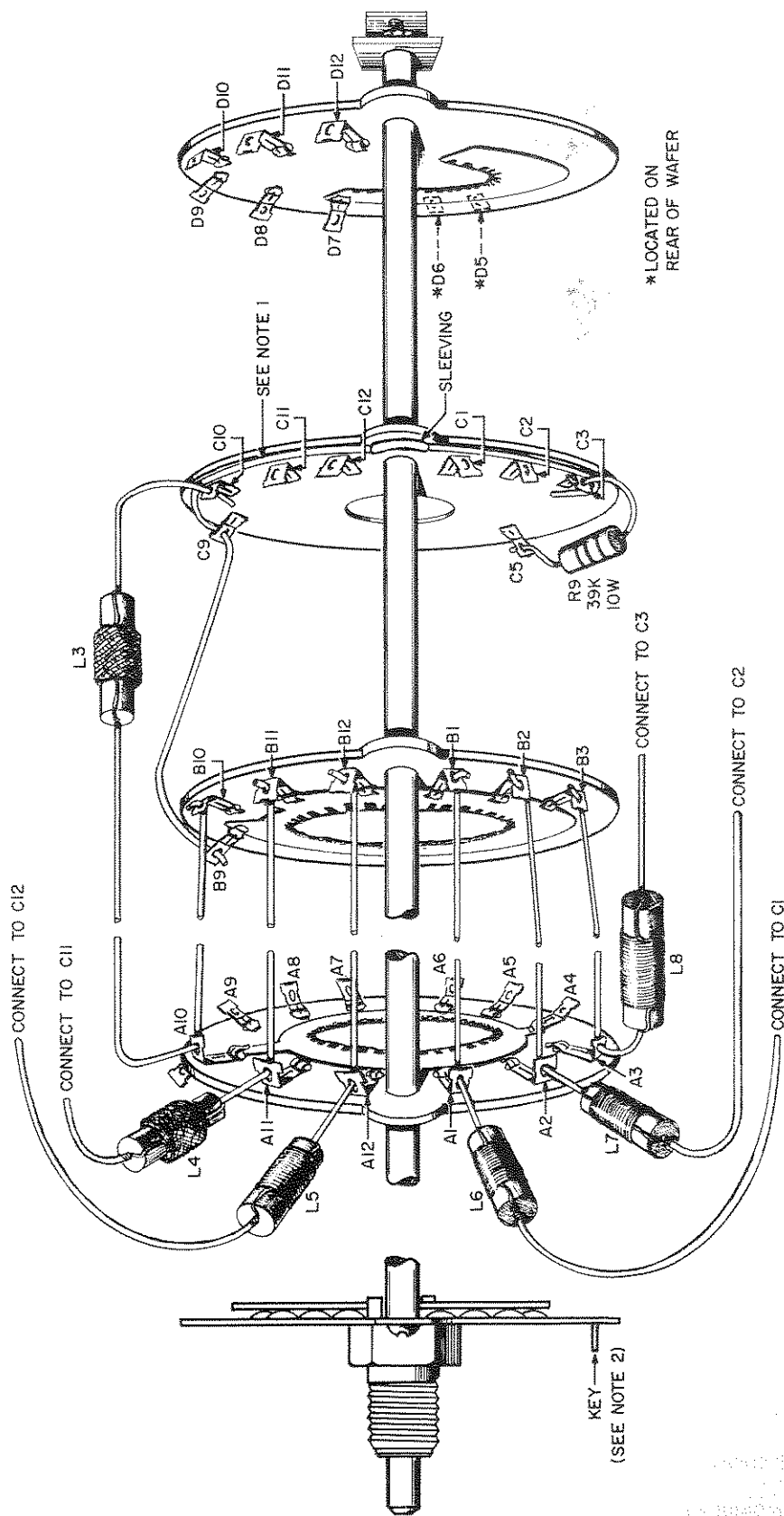

NOTES:
 1. BARE TINNED WIRE CONNECTED AT C3, DRAWN TIGHT OVER C2, C1, SWITCH SUPPORT ROD SPACER, C12, C11, C10 AND CONNECTED AT B10. SLEEVING USED AT SWITCH SUPPORT ROD SPACER.
 2. SWITCH LOCATING KEY IS BETWEEN TERMINALS 3 AND 4.

Figure 17. Wiring and Terminal Numbering of the Bandswitch.

NOTE

Be sure that the wire passes over terminals 10, 11, 12, 1, and 2 and not through the holes in these terminals. The wire will be soldered to these terminals after connecting the coils.

- (✓) Cut the leads of R9, a 39K ohm 1 watt resistor (orange-white-orange), to 1/2 inch on both ends. Connect one lead of R9 to terminal 5, section C, of the bandswitch S2 (S-2).
- (✓) Connect the other end of R9 to terminal 3, section C, of switch S2 (DS).
- (✓) Connect the outer conductor (shield braid) of the black, precut RG-58/U cable to the solder lug at the foot of the bandswitch (S2) mounting bracket as shown in Pictorial 6 (DS).
- (✓) Connect the center conductor at this end of the cable to terminal 7 on section D of the bandswitch S2 (DS).
- (✓) Connect the outer conductor (shield braid) on the other end of this cable to the solder lug on the base of the antenna connector J5 (S-1).
- (✓) Connect the center conductor at this end of the cable to the center terminal of the antenna connector J5 (DS).
- (✓) Cut the leads of C38, a .001 MFD ceramic disc capacitor, to 1/2 inch on each end.
- (✓) Connect one lead of C38 to terminal 1 of TS-18 (DS).
- (✓) Connect the other lead of C38 to terminal 2 of TS-18 (DS).
- (✓) Cut the leads of R22, a 2200 ohm 1/2 watt resistor (red-red-red), to 1/2 inch on each end.
- (✓) Connect one lead of R22 to terminal 2 of TS-18 (S-2).
- (✓) Connect the other lead of R22 to terminal 3 of TS-18 (DS).
- (✓) Cut the leads of CR3, a 1N295 diode, to 1/2 inch on each end.
- (✓) Connect the lead on the K end of CR3 to terminal 3 of TS-18 (DS).
- (✓) Connect the other lead of CR3 to terminal 1 of TS-18 (S-3) (use heat sink).
- (✓) Cut the leads of R23, a 3300 ohm, 1 watt resistor (orange-orange-red), to 3/4 inch on each end.
- (✓) Connect one lead of R23 to terminal 3 of TS-18 (S-3) (Use heat sink).
- (✓) Connect the other lead of R23 to the center terminal of the antenna connector J5 (S-2).
- () Cut the leads of C40, C41, C42 and C43, all .001 mfd 500V ceramic disc capacitors, to 1/2 inch on each end.
- (✓) Connect one lead of C41 to terminal 1 of TS-17 (DS).
- (✓) Connect the other lead of C41 to terminal 2 of TS-17 (DS).
- (✓) Connect one lead of C40 to terminal 2 of TS-17 (S-2).
- (✓) Connect the other lead of C40 to terminal 3 of TS-17 (DS).
- (✓) Connect one lead of C43 to terminal 1 of TS-16 (DS).

- (✓) Connect the other lead of C43 to terminal 2 of TS-16 (DS).
- (✓) Connect one lead of C42 to terminal 2 of TS-16 (S-2).
- (✓) Connect the other lead of C42 to terminal 3 of TS-16 (DS).
- (✓) Locate the AC line cord and line cord lock. Place the line cord lock 2 inches from the stripped and tinned ends of the cord, (refer to Figure 18A).
- (✓) Push the line cord through hole 54 on the rear flange of the chassis.
- (✓) Secure the line cord lock as shown in Figure 18B and push into hole 54.
- (✓) Connect one lead of the line cord to terminal 1 of TS-17 as shown in pictorial 6 (DS).
- (✓) Connect the other lead of the line cord to terminal 3 of TS-17 (DS).
- (✓) Cut the leads of line chokes L14 and L15 to 3/4 inch on each end.
- (✓) Connect one lead of L15 to terminal 1 of TS-16 (S-3).
- (✓) Connect the other lead of L15 to terminal 1 of TS-17 (S-3).
- (✓) Connect one lead of L14 to terminal 3 of TS-16 (S-3).
- (✓) Connect the other lead of L14 to terminal 3 of TS-17 (S-3).
- (✓) Locate the red precut miniature coaxial cable and connect one end of the outer conductor (shield braid) to terminal 4 of TS-4 (S-2).
- (✓) Connect the center conductor at this end to terminal 3, section C, of the bandswitch S2 (DS).
- (✓) Connect the outer conductor (shield braid) at the other end of the coaxial cable to ground lug No. 3 of socket XV4 (S-4).
- (✓) Connect the center conductor at this same end to the top hole in terminal 5 of socket XV2 (S-1).
- (✓) Cut a piece of No. 22 bare tinned wire 1-1/2 inches long. Connect one end of this wire to terminal 6 on the rear of section D of the bandswitch S2 (S-1).
- (✓) Connect the other end of this bare wire to the ground lug at the foot of the bandswitch S2 mounting bracket (at the rear of switch S-2).

WIRING THE OUTPUT TANK COIL L10

- (✓) Cut a piece of yellow sleeving 3-3/8 inches long and slip over lead No. 2 on L10.
- (✓) Cut a piece of yellow sleeving 3-1/8 inches long and slip over lead No. 2 on L10.
- (✓) Cut a piece of yellow sleeving 2-7/8 inches long and slip over lead No. 4 on L10.
- (✓) Cut a piece of yellow sleeving 2-1/2 inches long and slip over lead No. 5 on L10.
- (✓) Cut a piece of yellow sleeving 1-7/8 inches long and slip over lead No. 6 on L10.
- (✓) Cut a piece of yellow sleeving 2-1/8 inches long and slip over lead No. 7 on L10.

NOTE

There should be 1/4 inch of bare wire protruding beyond the yellow sleeving on each of the above leads.

- (✓) Dress the leads of L10 with the yellow sleeving as shown in Figure 19.
- (✓) Feed leads 2 through 7 (with yellow sleeving) of L10 down through hole No. 55 to a point where leads 1 and 8 are in a position to be placed into the solder lugs on the top of the standoff insulators (at holes 37 and 38 in chassis) as shown in Figure 20.
- (✓) Connect leads 1 and 8 at each end of L10 to the bottom hole in the solder lugs on the standoff insulators (DS).

NOTE

Because of the stiffness of the coil leads EXTREME CARE should be taken not to break or bend the terminals on the bandswitch when connecting leads to the terminals.

- (✓) Connect lead 7 from coil L10 to terminal 7 of section D on bandswitch S2 (S-2).
- (✓) Connect lead 6 from coil L10 to terminal 8 of section D on bandswitch S2 (S-1).
- (✓) Connect lead 5 from coil L10 to terminal 9 of section D on bandswitch S2 (S-1).
- (✓) Connect lead 4 from coil L10 to terminal 10 of section D on bandswitch S2 (S-1).
- (✓) Connect lead 3 from coil L10 to terminal 11 of section D on bandswitch S2 (S-1).
- (✓) Connect lead 2 from coil L10 to terminal 12 of section D on bandswitch S2 (S-1).
- (✓) Solder leads 1 and 8 from coil L10 to the bottom holes of the solder lugs on top of the standoff insulators.
- (✓) Cut both leads of C26, a 47 mmf., 2KV ceramic disc capacitor, to 1/2 inch. Add a 4-1/2 inch piece of No. 22 bare tinned wire to one lead of the capacitor and solder the joint. Slip a 3-1/2 inch piece of yellow sleeving over this long lead. Connect this lead through hole 55 to terminal 5 on the rear of section D of the bandswitch S2 (S-1).
- (✓) Connect the other lead of C26 to terminal 1 of the plate tuning capacitor as shown in Pictorial 3 (S-1).
- (✓) Cut a piece of No. 16 bare tinned wire 2-1/2 inches long. Twist terminals 2 and 3 of the plate loading capacitor C25 and insert the end of the No. 16 bare wire into both terminals. Slide the wire through the terminals on the capacitor far enough to permit the other end to slip back freely into the solder lug on the top of the standoff insulator (bending it slightly if necessary) as shown in Pictorial 3. After the wire is in place, solder all three terminals.
- () Cut a piece of No. 16 bare tinned wire 2-1/4 inches long. Twist terminals 2 and 3 of the plate tuning capacitor C17 in the same manner as on the plate loading capacitor C25 above.
- () Insert the No. 16 wire into terminals 2 and 3. Solder both terminals. There will be approximately 1 inch of lead extending from terminal 2 of C17 toward the back of the chassis. Bend this lead as shown in Pictorial 3. The 6-meter coil will be connected to the end of this lead later.
- () Locate the six-meter tank coil L9 and slip the end of the coil with the hook over the free end of the wire soldered to terminals 2 and 3 of the plate tuning capacitor C17 positioning the 6-meter coil as shown in Pictorial 3.

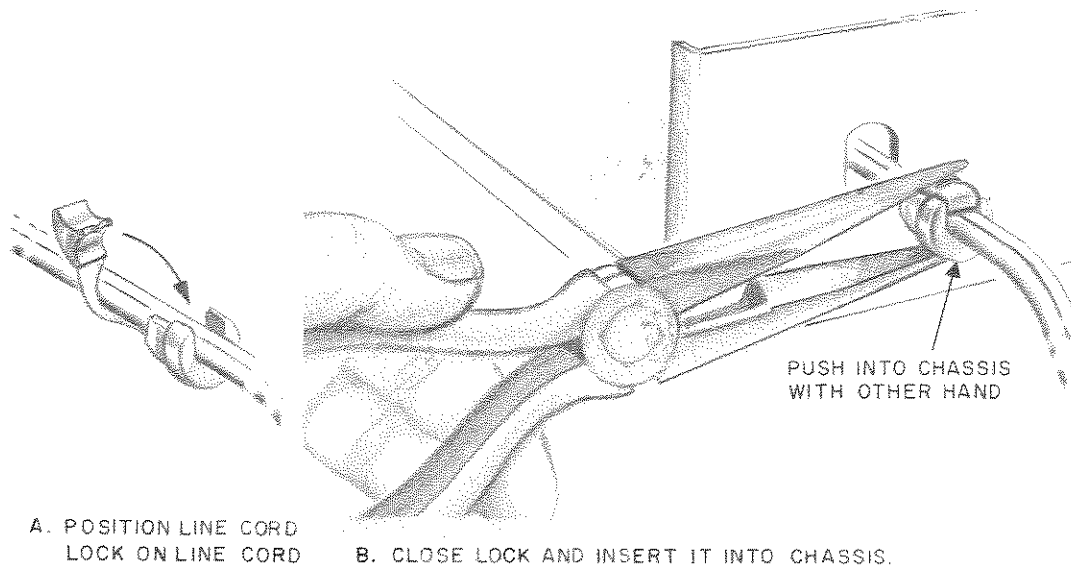

Figure 18. Installation of Line Cord Lock.

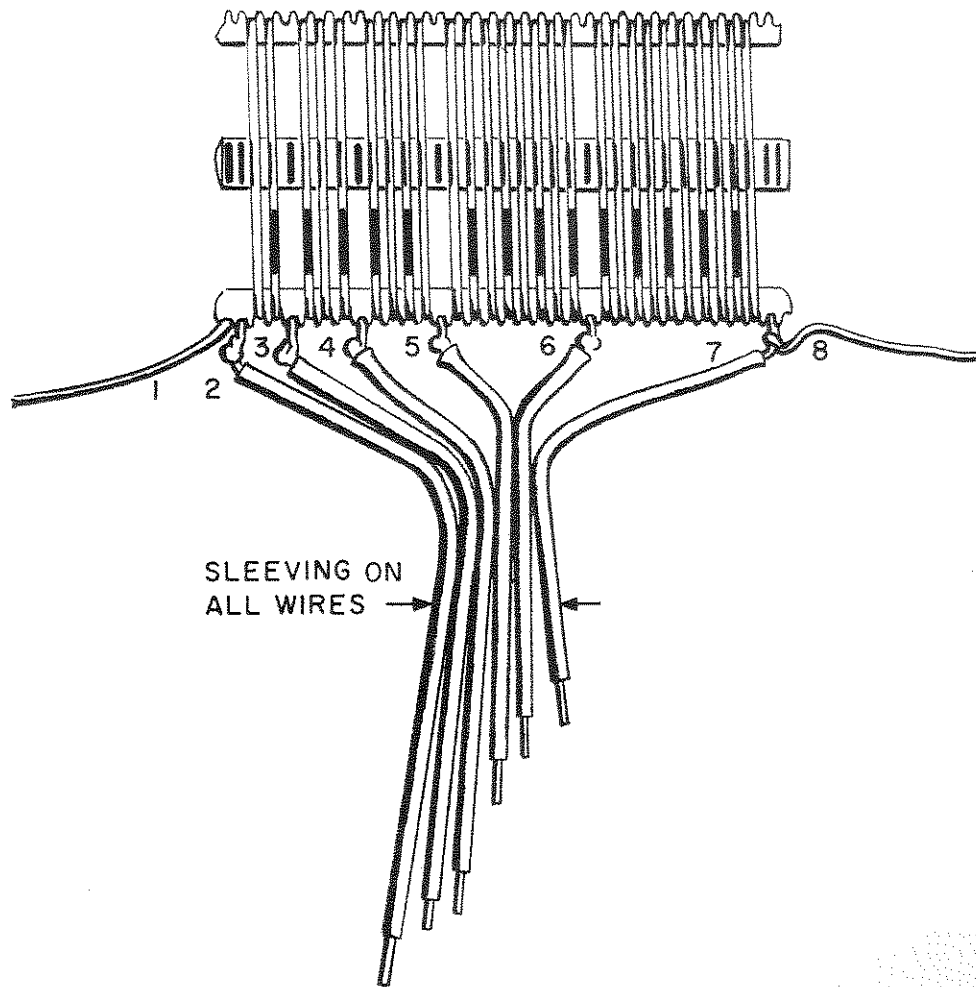

Figure 19. Dressing Leads of Output Tank Coil L10.

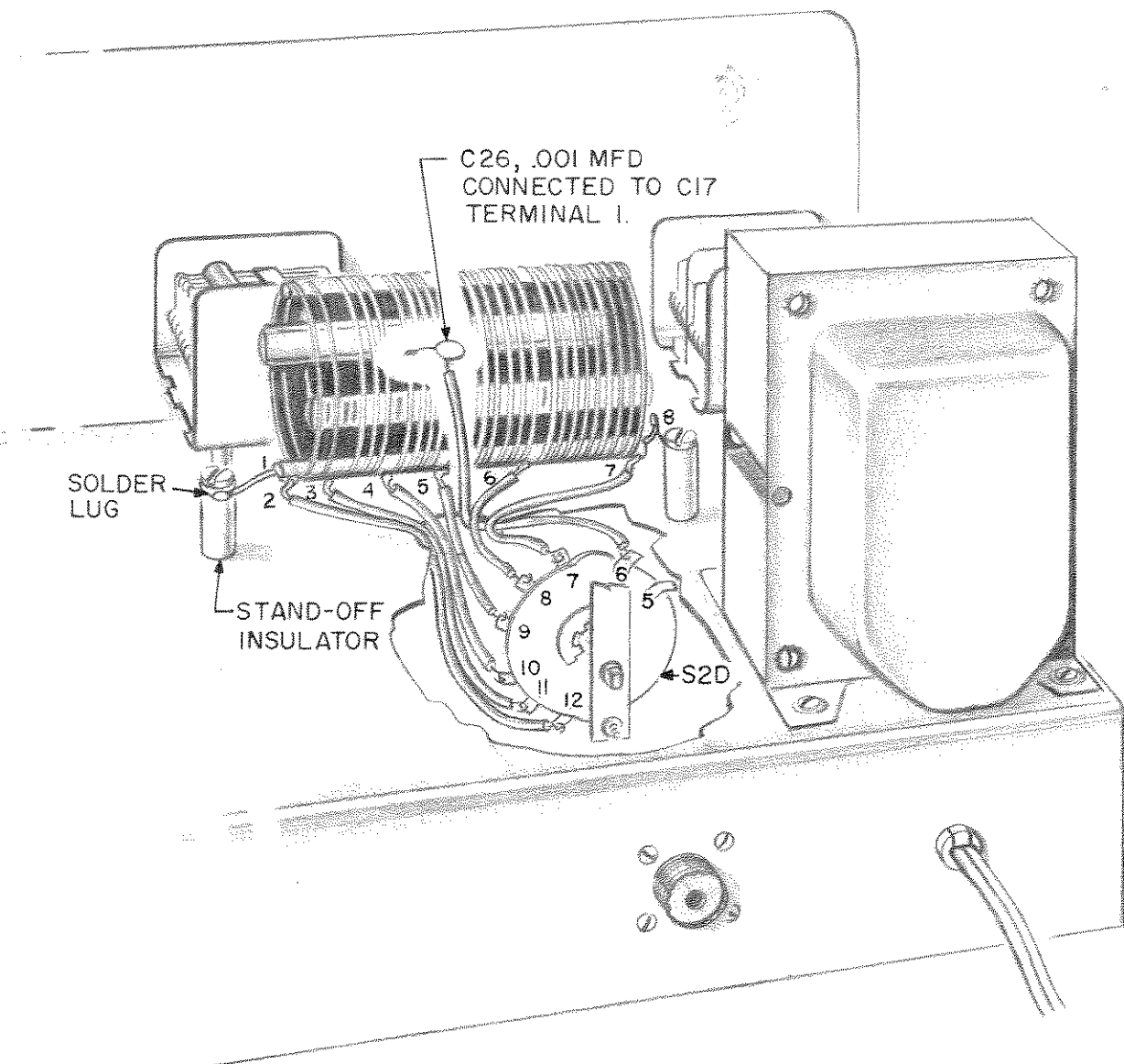

Figure 20. Mounting Output Tank Coil L10.

- (✓) Crimp the hook tightly over the end of the wire and solder.
- (✓) Connect the other end of L9 to the top hole of the terminal lug on top of the standoff insulator, located at hole 37 on top of chassis (S-1).
- (✓) Mount the output plate choke L13 at hole 56 using a No. 6-3/8 inch long sems screw and a fiber washer. Insert the sems screw through hole 56, then slip the fibre washer over the screw and thread the screw into the choke L13 as shown in Pictorial 3 and then finger tighten the screw. Do not tighten the screw too much as this may break the ceramic coil form.
- (✓) Connect the white wire coming up through hole No. 51 to the bottom lug of L13 (DS).
- (✓) Cut the leads of C37, a .005 mfd. 1000 V ceramic disc capacitor, to 5/8 inch.
- (✓) Connect one lead C37 to bottom lug of L13 (S-2).
- (✓) Connect the other lead of C37 to terminal 1 of TS-6 (S-1).
- (✓) Connect one lead of C18, a .001 mfd. 3KV ceramic disc capacitor, to the No. 16 bare tinned wire at the point where the lead is soldered to L9, the 6-meter coil, and solder at this point.
- (✓) Connect the other lead of C18 to the solder lug on the top of L13 (DS).
- (✓) Prepare the parasitic choke assembly as shown in Figure 21 and Pictorial 3.
- (✓) Connect the free end of the parasitic choke assembly to the solder lug on top of L13 (S-2).

FRONT PANEL ASSEMBLY
(Refer to Figure 22)

- (✓) Install the two pin jacks, J1 and J2 on the front panel. The red pin jack J2 mounts toward the top of the panel, the black pin jack, J1 mounts toward the bottom of the panel.
- (✓) Install the meter on the panel.
- (✓) Install the pilot light assembly on the panel.
- (✓) Remove the palnuts from the function switch and the bandswitch, and install the panel. Replace the palnut on the function switch, but leave the palnut off the bandswitch.
- (✓) Install the key jack through hole 57 using the flat 3/8 inch washer and the nickel plated 3/8 inch nut. Thread the nut on the bandswitch and tighten all three nuts. This completes the assembly of the front panel.
- (✓) Cut the leads of R25 a 56K ohm 1/2-watt resistor (green-blue-orange), to 1/2 inch on both ends. Connect one lead to terminal 3 of TS-4(S-2) as shown in Pictorial 6.
- (✓) Connect the other lead to terminal 2 of TS-4 (DS).
- (✓) Cut two pieces of yellow sleeving 1-1/2 inches long. Slide these pieces of sleeving over the pilot light leads. Feed leads, with sleeving, down through hole No. 58, toward TS-4. Connect the other lead to terminal 2 of TS-4(DS).
- (✓) Connect the other lead from the pilot light to terminal 1 of TS-4 (S-2).
- (✓) Cut a red wire and a black wire each 6 inches long. Strip the ends of both wires 3/8 inch.
- (✓) Connect one end of the red wire to terminal 4 of S4 (S-1).
- (✓) Connect one end of the black wire to terminal 3 of S4 (S-1) as shown in Pictorial 7.

INSERT RESISTOR IN COIL &
CONNECT PIGTAILS 1&3 TO
ENDS OF COIL 2&4. CONNECT
PLATE CAP TO END OF
RESISTOR PIGTAIL.

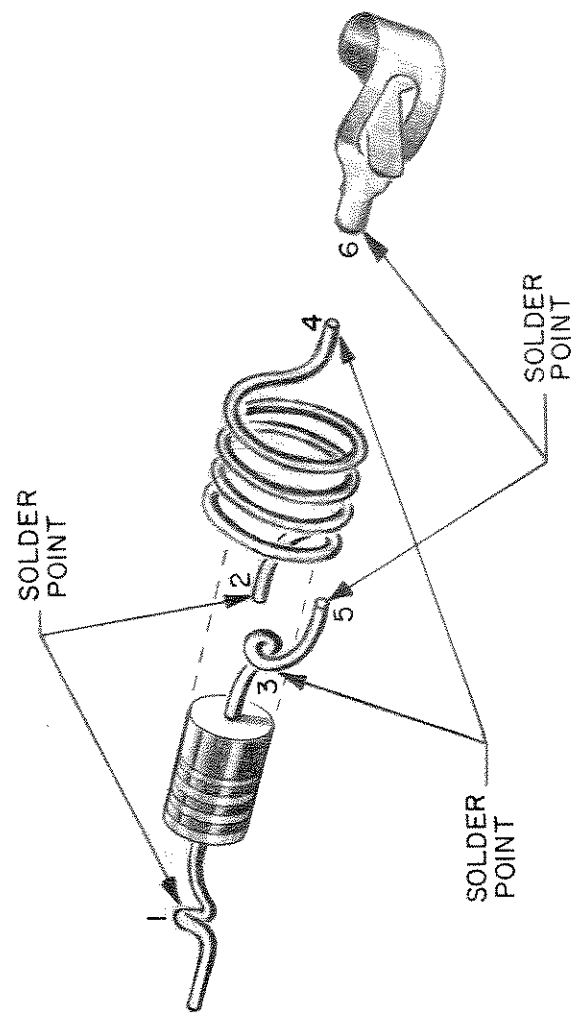

Figure 21. Parasitic Choke Assembly.

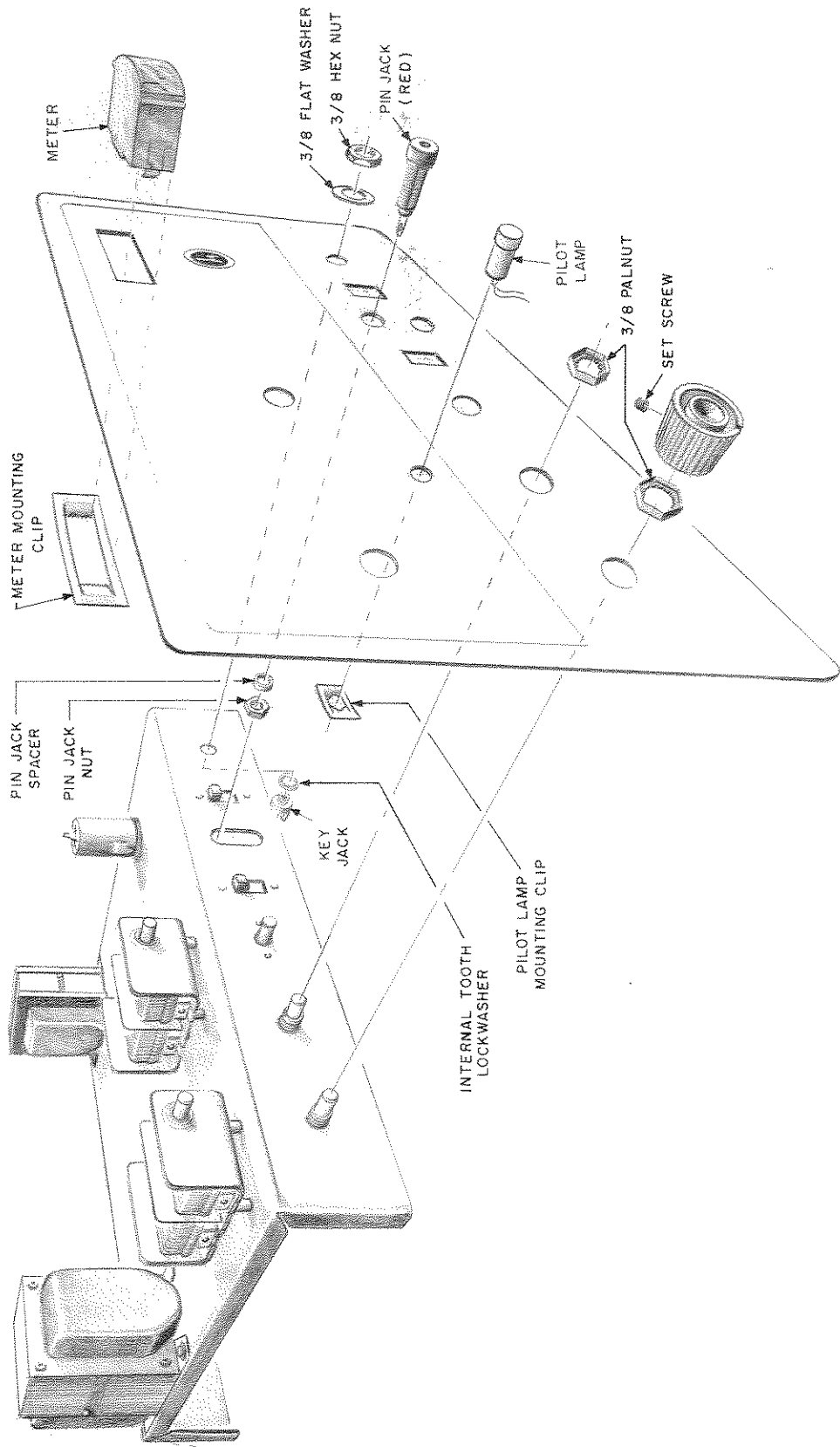

Figure 22. Front Panel Assembly.

- (✓) Twist both wires together and feed them through hole 59 toward the meter terminals.
- (✓) Cut both leads of C22, a 100 MFD-15V electrolytic capacitor to 3/4 inch on each end.
- (✓) Connect the other end of the red wire connected to terminal 4 of S4 along with the plus lead of the 100 MFD-12V electrolytic capacitor C22 to terminal 1 of the meter, tighten the terminal screw (Figure 23).
- (✓) Connect the other end of the black wire connected to terminal 3 of S4 along with the negative lead from C22 to terminal 2 of the meter, tighten the screw.
- (✓) Connect the white wire with the black tracer protruding from the end of cable harness WH-2 to terminal 2 of key jack J3 as shown in Pictorial 7 (S-1).
- (✓) Connect the other end of the violet wire connected to terminal 2 of TS-10 to terminal 3 of the Key Jack J3 as shown in Pictorial 7 (DS).
- (✓) Cut the leads of C3, a .005-1KV ceramic disc capacitor to 5/8 inch on each end. Connect one end of C3 to terminal 3 of J3 (S-2).
- (✓) Connect the other end of C3 to terminal 6 of S4 (S-4).
- (✓) Connect the other end of the green wire connected to terminal 2 of socket XV1 to the red pin jack terminal (S-1).
- (✓) Cut a piece of No. 22 bare tinned wire 1-3/4 inches long. Connect one end of this wire to terminal 2 of S1 (S-1).
- (✓) Connect the other end of this wire to the terminal of the black pin jack (S-1).

WIRING THE BAND SELECTOR SWITCH (Refer to Figure 17 and Pictorial 6)

- (✓) Cut a piece of white wire with a black tracer 2 inches long. Strip 3/8 inches on each end. Connect one end of this wire to terminal 2 on the drive capacitor (S-1).
 - (✓) Connect the other end of this wire to terminal 9 of switch S2, section A front, (green lug). This is the only terminal on the front of section A.
- Cut the leads of the 80 meter interstage coil L3 (white dot on end) to 7/8 inch on the end opposite the white dot and to 1/2 inch on the end with the white dot. Pass the 7/8 inch lead through terminal 10 on the rear of section A and just through terminal 10 on the front of section 10B (S-1).
- () Pass the 1/2 inch lead through terminal 10 on section C of switch S2 (S-2). Solder terminal 10 on the rear of section A.

NOTE

Installation of interstage coils L4 through L8 is identical to the installation of L3 except for the terminals used. Therefore, in the following installation steps for coils L4 through L8, refer back to the installation procedure for coil L3 for cutting of leads and installing.

- () Cut and install the 40 meter interstage coil L4 (yellow dot on end) using terminal 11. Solder all three terminals, in the same order as above.
- () Cut and install the 20 meter interstage coil L5 (red dot on end) using terminal 12. Solder all three terminals, in the same order as above.

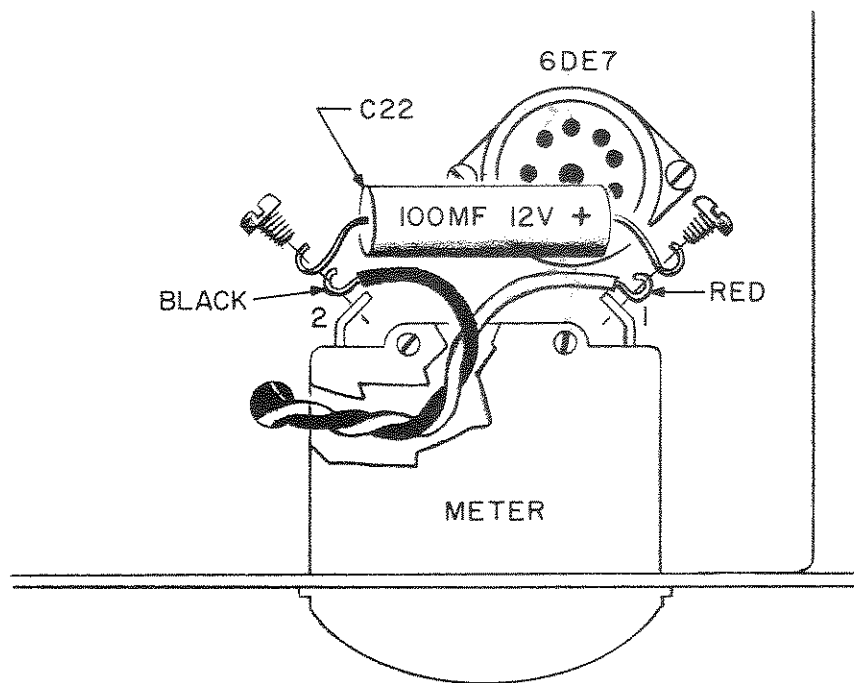

Figure 23. Wiring of Meter

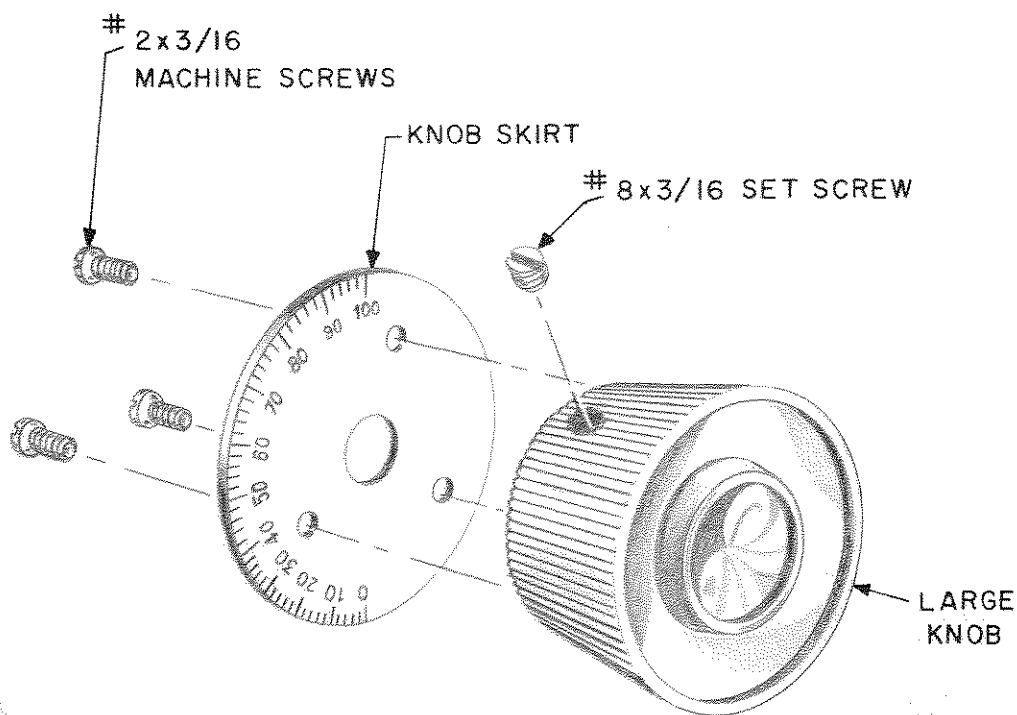

Figure 24. Assembly of Knob and Knob Skirt.

- () Cut and install the 15 meter interstage coil L6 (green dot on end) using terminals 1. Solder all three terminals, in the same order as above.
- () Cut and install the ten meter interstage coil L7 (brown dot on end) using terminal 2. Solder all three terminals, in the same order as above.
- () Cut and install the six meter interstage coil L8 (blue dot on end) using terminal 3. Solder all three terminals, in the same order as above, except that there will be 4 wires to solder at terminal 3 of section C.
- () Insert the tubes into the proper sockets as shown in Pictorial 3 and as indicated below:
 - 6DQ5 in socket XV2
 - 6CX8 in socket XVI
 - 6DE7 in socket XV4
 - 12AX7 in socket XV3
- () Slide shields over tubes 6CX8, 6DE7 and 12AX7.
- () Connect the plate cap on the parasitic choke assembly to the plate cap of the 6DQ5.
- () Locate the plate tuning and the plate loading knobs (knobs with three tapped holes on the bottom) the knob skirts, the six 3/16 inch machine screws, and the two No. 8 x 3/16 inch slot-head screws. Fasten the skirts to the knobs with the No. 2 x 3/16 inch screws, making sure that the scale graduations on the skirts are facing the knob as shown in figure 24. Thread the set screws into the body of the knobs.
- () Turn the plate tuning and the plate loading capacitors to full mesh (plates completely closed (see Figure 4). Insert the knobs on the shafts so that the 100 mark on the skirt is in line with the indicator mark on the panel. Tighten the set screws.
- () Locate the three small knobs and the three 8 x 3/16 inch slot head set screws. Insert the set screws in the knobs.
- () With the drive capacitor fully meshed (plates all the way in) set one knob on the shaft so that the red line on the knob is in line with the last dot on the right side of the panel. Tighten the set screw.
- () Place the second small knob on the bandswitch shaft and tighten the screw on the shaft at any position and rotate the bandswitch fully counterclockwise. Loosen the set screw and set the knob so that the red line is in line with 80 on the panel. Tighten the set screw knob.
- () Repeat as above for the installation of the third knob on the function switch shaft, except the red line on the knob should line up with the OFF on the panel.
- () Feed the line cord through the opening in the back of the cabinet and then carefully slide the wired chassis into the cabinet from the front. Secure the chassis in the cabinet with the ten No. 6 x 1/4 " thread forming screws.

This completes the assembly of the HT-40K Transmitter.

The Model HT-40K Transmitter is now ready for operation, refer to the Installation and Operation sections for installing and operating details. Should Malfunctions exist, carefully check the step by step assembly procedure. A Service section is provided at the back of this handbook to aid the builder in locating wiring errors or malfunctions which may occur during operation.

INSTALLATION

LOCATION.- The unit should be placed in a location that provides adequate space around it, to permit free circulation of air through the cabinet openings. Avoid excessively warm locations such as those on or near radiators and heating vents.

POWER SOURCE.- The HT-40K Transmitter is designed to operate on 105 to 125 volt, 60 cycle AC current. Power consumption is 175 watts.

IMPORTANT: If in doubt about the power source, contact your local power company prior to inserting the power plug into an AC power outlet. Plugging the power cord into the wrong power source can cause extensive damage to the unit, requiring costly repairs.

CRYSTAL - VFO RECEPTACLE.- The CRYSTAL-VFO receptacle consists of two pin jacks, mounted on the front panel, to accommodate .093" diameter pins with 1/2" center separation (similar to type FT-243 crystal holder). When an external VFO is used connect the high or "hot" side of the VFO output to the red pin jack and the ground side to the black pin jack.

KEY RECEPTACLE.- The KEY jack, a standard two conductor closed circuit type jack located on the front panel, provides for the connection of a hand keyer, a "bug" or an automatic keyer (T.O. Keyer). In addition to the KEY jack the keying instrument may be connected to terminals 3 and 4 of the four terminal strip located on the rear of the chassis. These contacts are connected in parallel with the KEY jack when the plug is removed from the jack.

MICROPHONE CONNECTOR.- The microphone connector, located on the rear of the chassis, is an Amphenol type 75-PC1M bulkhead receptacle and will accept an Amphenol type 75-MC1F microphone plug.

ANTENNAS.- It is suggested that a half-wave dipole antenna fed with a 50-ohm coaxial cable be used to radiate maximum power from the HT-40K (see figure 25). Refer to the ARRL ANTENNA HANDBOOK or similar publications for detailed information concerning transmitting antennas.

ACCESSORY TERMINAL STRIP.- A four-terminal strip on the rear of the chassis permits connecting the HT-40K to auxiliary equipments. The FUNCTION switch in the AM or CW position electrically connects terminals 1 and 2. When the FUNCTION switch is in either the OFF, TUNE or STANDBY position these terminals are not electrically connected. When terminals 1 and 2 are connected to auxiliary equipment such as an antenna change-over relay the FUNCTION switch controls the operation of the relay (see figure 26).

Terminals 3 and 4 connected across (in parallel with) the key jack terminals, when the plug is removed from the KEY jack, permits the HT-40K to be connected to a remote control switching device such as the SX-140 Receiver, SX-140K Receiver, a remote control switch or separate leads from the push-to-talk switch on the microphone (see figure 27). The HT-40K may be keyed by connecting a key to terminals 3 and 4. For remote control operation or keying from these terminals the key plug must be removed from the KEY jack and the shorting wire removed from terminals 3 and 4.

OPERATION

GENERAL.- The tuning procedure for the Model HT-40K Transmitter has been simplified by design to permit rapid adjustment of the Transmitter to the desired frequency. However, this does not mean that the transmitter may be operated successfully when only rough tuning adjustments are made. A clean signal from any transmitter requires good operating technique.

TUNING PROCEDURE FOR CW OPERATION.- The following tuning procedure must be performed prior to operating the transmitter in the CW mode.

EQUIPMENT REQUIRED:

1. 50 ohm non-inductive dummy load or a 40 watt light bulb (see figure 28).
2. Crystal with its fundamental or harmonic frequency corresponding to the desired transmitting frequency or an external VFO.

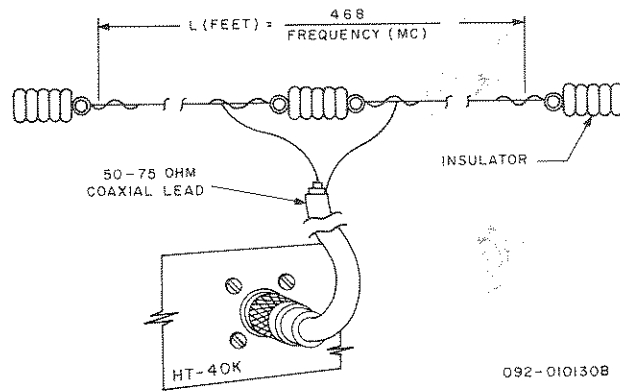

Figure 25. Coaxial Fed Half-Wave Dipole Antenna.

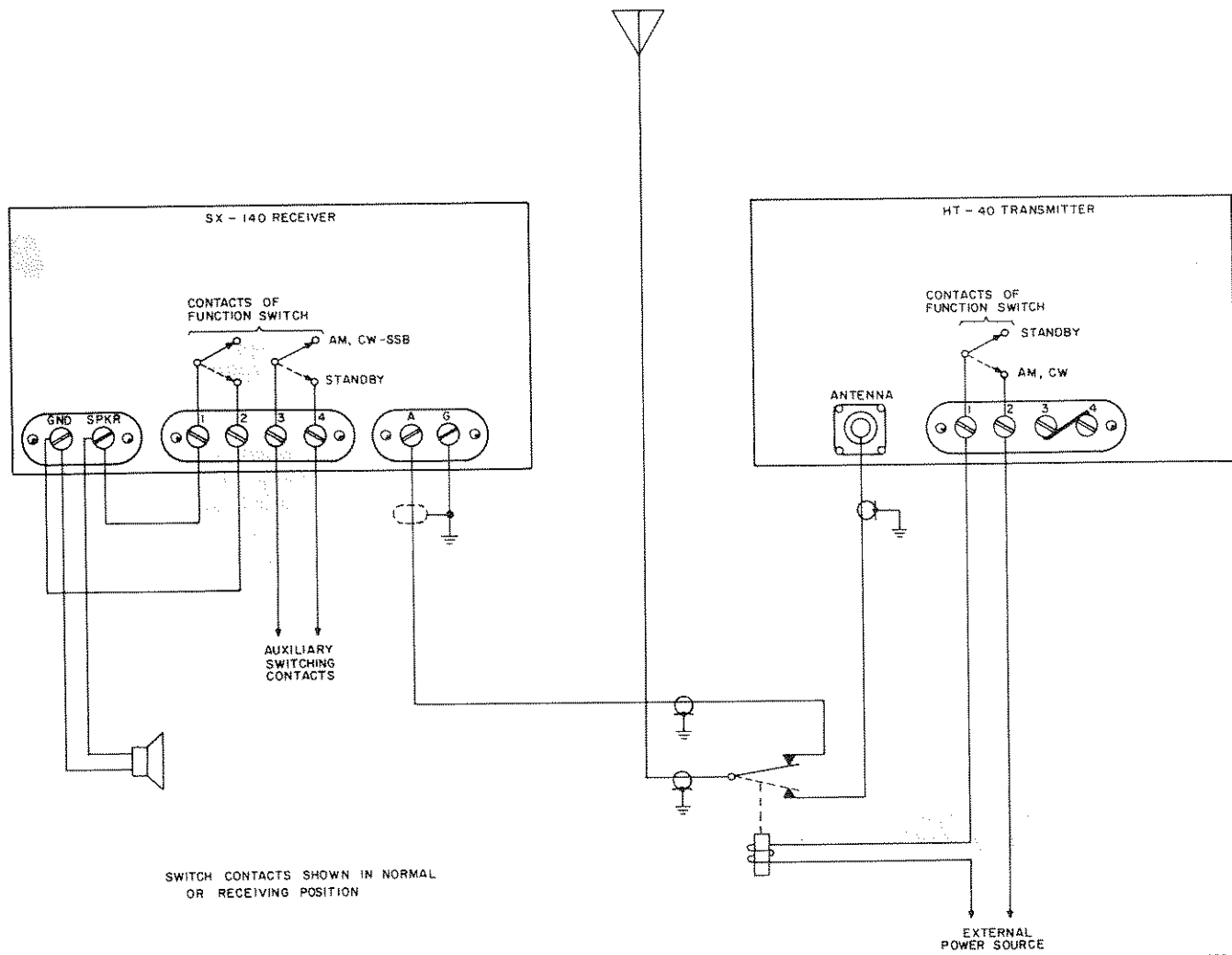

Figure 26. Model HT-40K Controlling Antenna Relay.

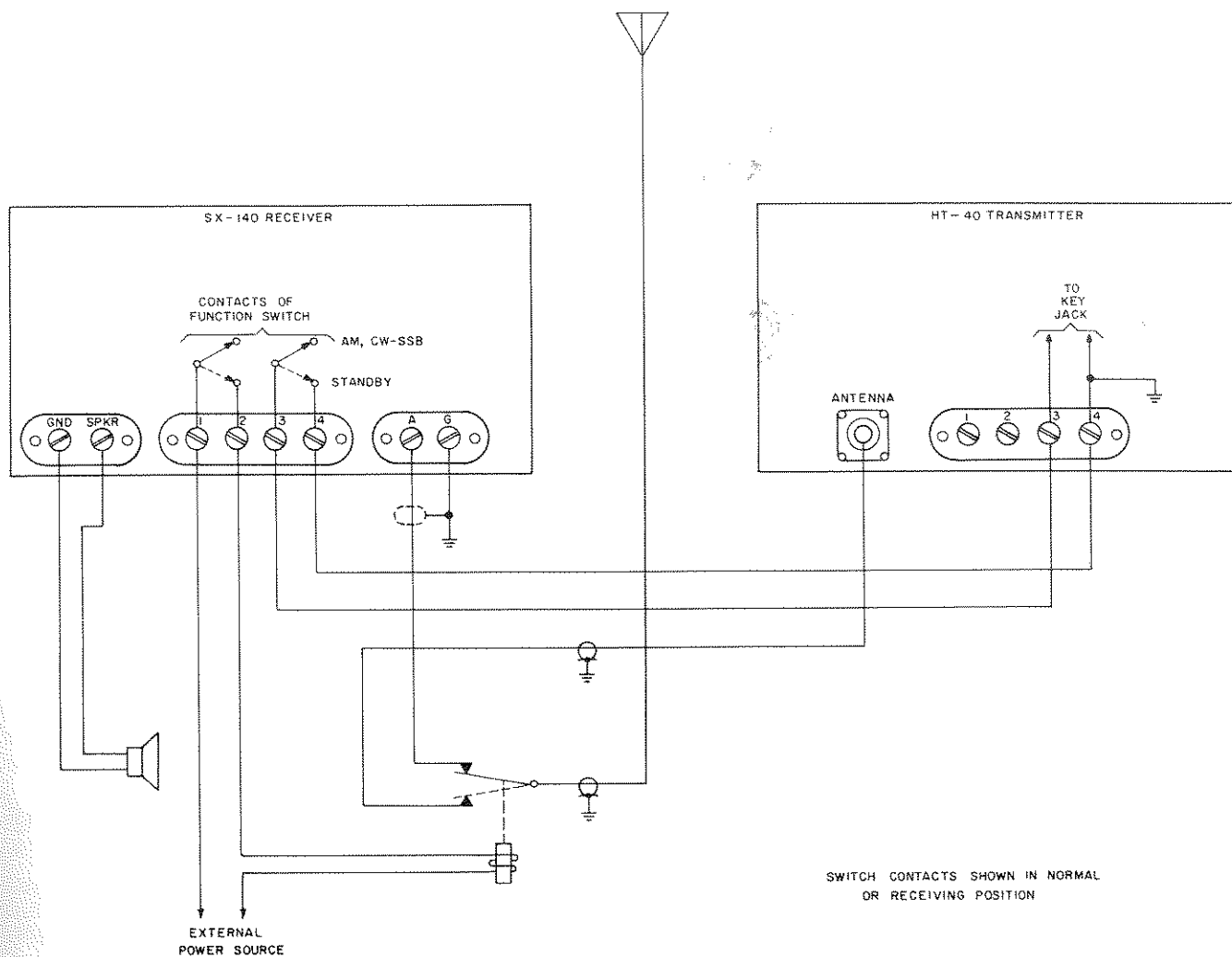

Figure 27. Model HT-40K Controlled by Station Receiver.

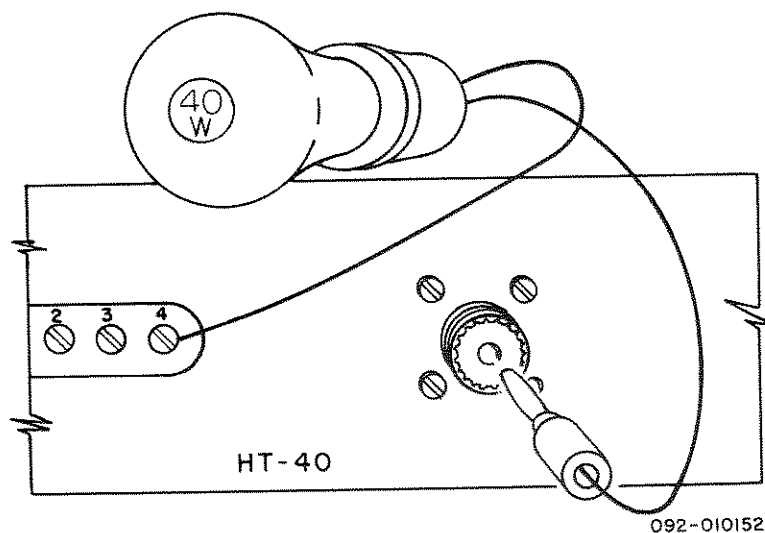

Figure 28. Light Bulb Used as Dummy Load.

PROCEDURE

1. Set the controls as indicated:

MIKE GAIN Maximum counterclockwise

FUNCTION OFF

BAND SELECTOR Desired band

DRIVE Center of range

CRYSTAL-VFO CRYSTAL

RF OUTPUT-GRID
CURRENT GRID CURRENT

PLATE LOADING

80 to 10 meter bands Near 100

6 meter band Near 0

PLATE TUNING

80 to 10 meter bands Near 100

6 meter band Near 0

2. Insert crystal of desired frequency into the CRYSTAL-VFO socket.
3. It may be desirable to insert the key plug into the KEY jack and close the key at this time to allow the operator to tune the transmitter, however, this is not necessary since the jack is a normal closed circuit type when the key plug is removed.
4. Connect the dummy load to the antenna connector on the rear chassis panel and plug the line cord into a 117 volt AC utility outlet.
5. Set FUNCTION control to STANDBY, allow approximately 5 minutes to warm up and then set FUNCTION control to TUNE.
6. Adjust DRIVE control for maximum deflection on the RF OUTPUT-GRID CURRENT meter.
7. Set RF OUTPUT-GRID CURRENT switch to the RF OUTPUT position.
8. Rotate FUNCTION control to CW.

NOTE

In steps 9,10 and 11 the final setting of the PLATE LOADING and PLATE TUNING controls will be near 100 on the 80 meter band and progressively lower on the 40 to 6 meter bands. On the 6 meter band two maximum output indications can be obtained. The correct setting will be between 0 and 20.

9. Adjust PLATE TUNING control for maximum output indication on the meter.
10. Adjust PLATE LOADING control for maximum output indication on the meter.
11. Repeat steps 9 and 10 until maximum output is obtained; note the approximate meter reading.
12. Turn Transmitter off with the FUNCTION control, disconnect the dummy load and connect the transmitting antenna.

13. Rotate the FUNCTION control to CW and note output indication. If the antenna impedance is approximately the same as that of the dummy load the meter indication will be approximately the same as that noted in step 11. If the antenna line is open a higher indication will be noted: if the antenna line is shorted approximately zero indication will be noted.
14. If the proper indication is obtained on the meter the HT-40K is ready for CW operation.

TUNING PROCEDURE FOR AM OPERATION. - The procedure for tuning the Transmitter for AM operation is identical to the tuning procedure for CW operation, step 1 through step 12 except that the CW key need not be plugged in. The following procedure will complete the tuning of the transmitter for AM operation:

1. Connect the microphone to the MIKE connector on the rear of the chassis.
2. Rotate the FUNCTION control to AM; note the meter indication, it should be approximately one fourth the indication noted in step 11.
3. While talking in a normal voice level two or three inches from the microphone and observing the meter, advance the MIKE control clockwise until a peak indication is observed during "talk" periods which is slightly below the indication noted in step 11. This provides 75% to 90% AM modulation as shown in figure 29, if it is desired to use a scope.

SERVICE

SERVICE POLICY

Facilities of the Hallicrafters Service Department are available for repair, service, and technical consultation by mail. If continued operational difficulties result with completed kit, a letter to Hallicrafters may help solve the problem.

REPAIR PROCEDURE

Hallicrafters Model HT-40K Transmitter Kit may be returned for inspection and repair at a special service charge of \$12.50 during the first year after purchase. This special price applies only to kits that have been completed and wired according to the instructions contained within this material. Any kits that are not completed or that have been modified will not be accepted for repair. Charges for replacement parts will be determined by the warranty status of the equipment when it is received for service. The builder is to be reminded that the registration card furnished with each Hallicrafters Kit must be completed and returned to The Hallicrafters Company immediately after purchase. The warranty is applicable only to equipment that is registered with Hallicrafters factory.

After the first year, service charges will be based on the labor time required to make repairs and the cost of any parts or material needed to complete the repairs.

NOTE

KITS SHOWING EVIDENCE OF WIRING WITH ACID CORE SOLDER
OR PASTE FLUXES WILL NOT BE ACCEPTED FOR REPAIR OR
SERVICE AND WILL BE RETURNED UNREPAIRED.

Before returning a kit for service or repair, please notify The Hallicrafters Company and a shipping label and a return authorization will be mailed to the requester.

When writing, include the following information:

1. Model number of kit.
2. Serial number.
3. Date of purchase
4. Description of trouble.

Address the letter to:

The Hallicrafters Company
Service Department
Attention: Kit Division
4401 West Fifth Avenue
Chicago 24, Illinois

After a Return Authorization has been received from Hallicrafters, pack the kit in a container sufficiently padded to prevent damage in shipment. (Shipping companies will not accept responsibility for any damage that may occur in transit if the kit is improperly packed.) Attach the label and send the kit to the above address prepaid and insured.

Upon completion of repairs, the kit will be returned to the owner C.O.D. To save C.O.D. fees, advance remittance may be sent with the kit for standard repair charges and return transportation charges.

PARTS REPLACEMENT

Each component in a Hallicrafters kit has been inspected to meet rigid factory specifications and to assure proper performance in the completed equipment. A 90-day warranty, effective from the date of purchase, covers the parts supplied with each kit. If a part should fail during this period, notify the factory and replacement will be made in accordance with the conditions outlined in the warranty.

Do not return the component or part without prior authorization. Should replacement be necessary, forward the following information:

1. Model number of kit.
2. Serial number.
3. Date of purchase.
4. Part number and description of component as shown in the manual.
5. Description of defect and reason for replacement request.

No replacement can be made for any parts damaged during construction and assembly of the kit.

Circuit tubes should be carefully packed to avoid the possibility of breakage in shipment. Broken tubes will not be replaced.

MAINTENANCE SUGGESTIONS

In the HT-40K as in all well-designed communications equipment, maintenance and repair problems are generally confined to checking and replacing defective tubes. Malfunctions of this nature are easily isolated and corrected by tube substitution. Should malfunctions other than faulty tubes occur refer to the schematic diagram for proper voltage, resistance, and capacity values.

The following table provides suggestions for servicing the HT-40K. It is possible that this table is incomplete as there are numerous causes for improper operation of any piece of equipment which can only be determined with elaborate instruments and a complete knowledge of the entire circuit. However, each component of the HT-40K is pretested, before packing, thus the table will provide adequate servicing information in most instances.

Trouble Shooting

Symptom	Possible Cause
No output on any band (AM or CW)	<ol style="list-style-type: none"> 1. V1 or V2 defective. 2. T1, L16 and/or associated power supply components defective. 3. Shorted antenna.
No AM modulation on any band; CW operation function properly	<ol style="list-style-type: none"> 1. V3 or V4 defective. 2. Microphone and/or associated components in the audio system defective.
No output on any one band	<ol style="list-style-type: none"> 1. Defective interstage coil for particular band. 2. BAND SELECTOR defective. 3. Oscillator Crystal defective.

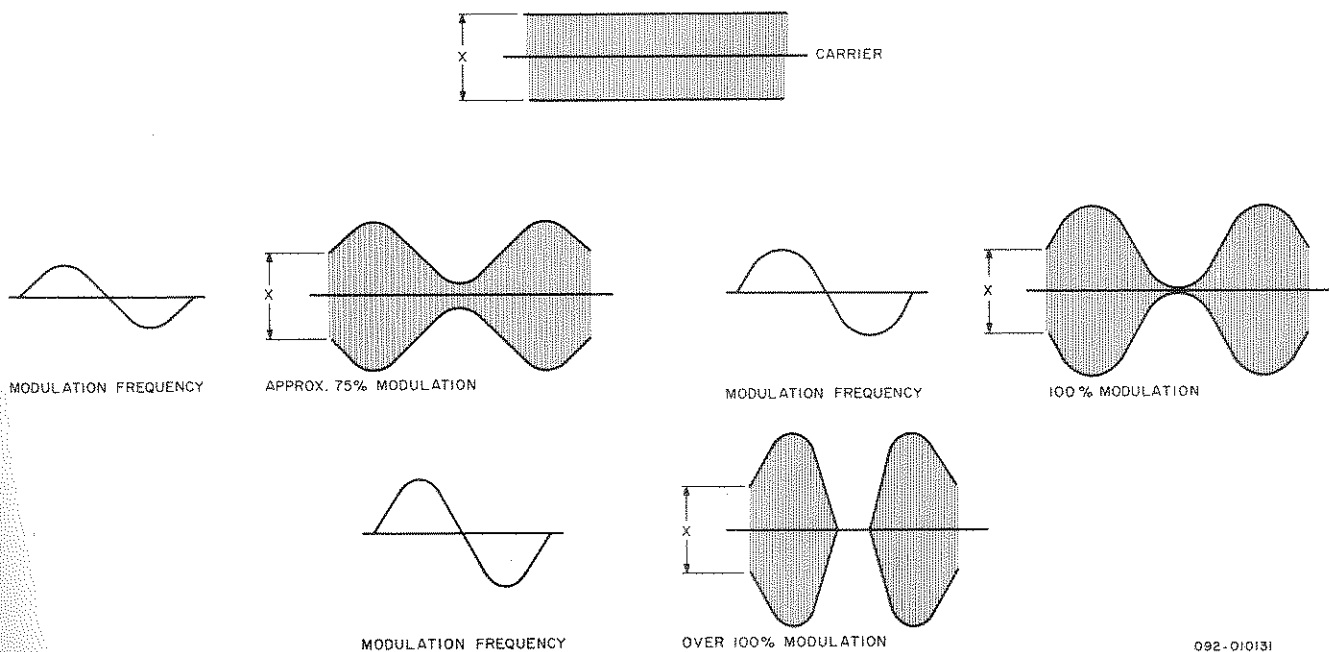
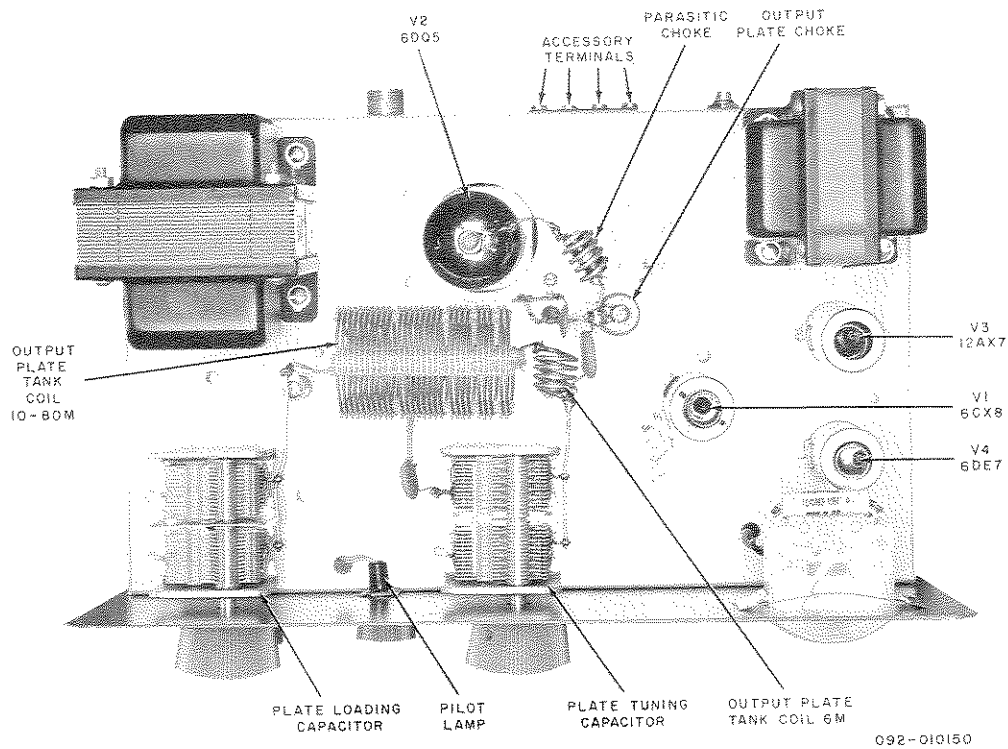
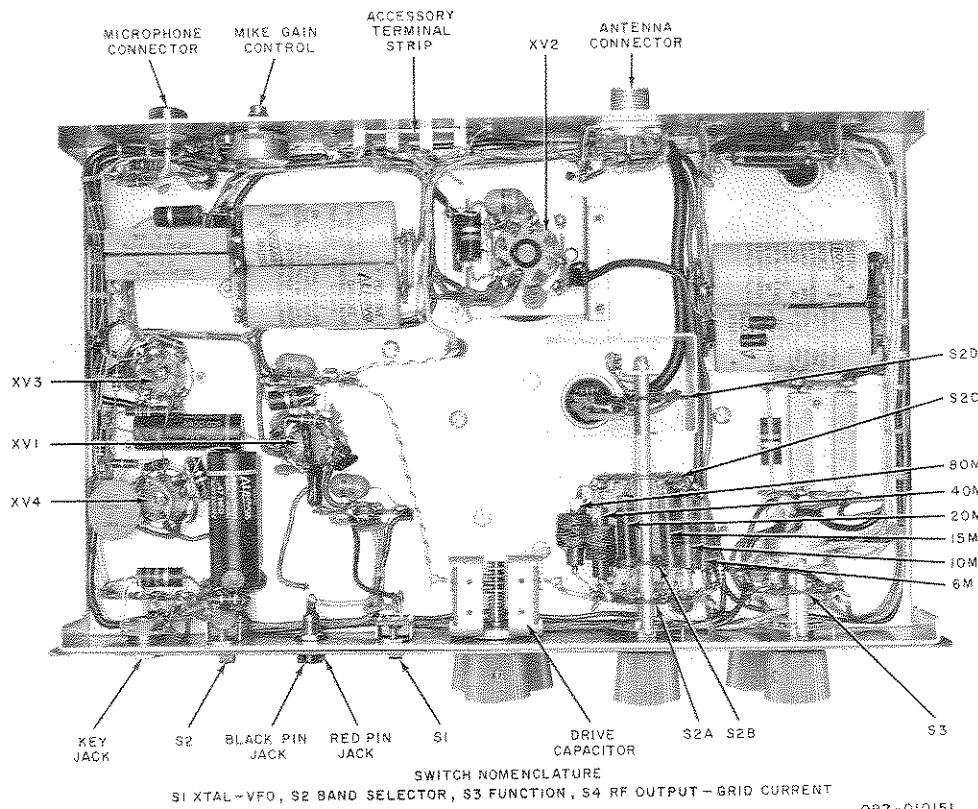

Figure 29. Carrier Modulation Patterns.



Top View



Bottom View

COMPLETED TRANSMITTER CHASSIS

ITEM NO	PART NUMBER	DESCRIPTION	QTY	REF SYMBOL
✓ 1	098-000659	Shipping Container	1	
✓ 2	150-901138	Cabinet	1	
✓ 3	048-000496	Capacitor, Plate Tuning	1	C17
✓ 4	048-000495	Capacitor, Plate Loading	1	C25
✓ 5	048-000499	Capacitor, Drive	1	C15
✓ 6	090-901418	Electron Tube, 6CX8	1	V1
✓ 7	090-900038	Electron Tube, 12AX7	1	V3
✓ 8	090-901419	Electron Tube, 6DE7	1	V4
✓ 9	069-100430	Shield, Tube	3	
✓ 10	069-001417	Base, Tube Shield	3	
✓ 11	070-002022	Chassis	1	
✓ 12	052-000852	Transformer, Power	1	T1
✓ 13	056-000446	Filter Choke, 5H	1	L16
✓ 14	090-901420	Electron Tube, 6DQ5	1	V2
✓ 15	051-003022	Coil, Output Tank, 80-10 Meters	1	L10
✓ 16	053-000621	Choke, Parasitic	1	L11
✓ 17	051-003052	Coil, Output Tank, 6 Meters	1	L9
✓ 18	060-002265	Switch, Rotary, BAND SELECTOR	1	S2
✓ 19	060-002268	Switch, Rotary, FUNCTION	1	S3
✓ 20	082-000493	Meter, RF OUTPUT-GRID CURRENT	1	M1
✓ 21	067-008881	Bracket, Tube Mounting	1	
✓ 22	069-001402	Shield, Electrical	1	
✓ 23	015-301315	Knob, Plate Loading and Plate Tuning	2	
✓ 24	015-201358	Knob, Function and Band Selector	3	
✓ 25	087-100078	Line Cord	1	P1

ITEM NO.	PART NUMBER	DESCRIPTION	QTY	REF SYMBOL
26	003-100973	Setscrew, #8 x 3/16	5	
27	416-040311-04	Screw, Thread Forming, #6 x 1/4	12	
28	002-102142	Palnut, 3/8 (Parkerized)	2	
29	413-045312-06	Screw, Sems, #6 x 3/8	15	
30	002-102188	Nut, Kep, #6	9	
31	406-045212-04	Screw, Flat Head, #6 x 1/4	2	
32	427-001422	Washer, Lock, Internal Tooth 1/2 in.	1	
33	060-200967	Switch, Slide, SPDT, XTAL- VFO	1	S1
34	406-023212-04	Screw, Flat Head, #4 x 1/4	4	
35	060-002260	Switch, Slide, DPDT, RF OUTPUT-GRID CURRENT	1	S4
36	036-000294	Jack, Pin, Red	1	J2
37	036-000295	Jack, Pin, Black	1	J1
38	036-100002	Jack, Phone, KEY	1	J3
39	004-002219	Washer, Lock, Internal Tooth, 3/8 in.	1	
	004-100133	Washer, Flat, 3/8 in.	1	
	002-200806	Nut, Hex, 3/8	1	
40	025-0001949	Resistor, Variable, 1 Megohm, MIKE GAIN	1	R16
41	002-101032	Palnut, 3/8	1	
42	029-100566	Connector, Microphone	1	J4
43	427-001222	Washer, Lock, Internal tooth, 3/8 in.	1	
44	010-100056	Connector, Antenna	1	J5
45	413-023312-05	Screw, Sems, #4 x 5/16	27	
46	426-001343	Washer, Lock, Internal tooth, #4	27	
47	401-023222	Nut, Hex, #4	27	
48	011-100054	Solder Lug, #6	6	

ITEM NO.	PART NUMBER	DESCRIPTION	QTY	REF SYMBOL
49	088-301145	Terminal Strip	3	TS-16, TS-17, TS-18
50	073-003691	Spacer, Capacitor Mounting, 3/4 in.	6	
51	413-045312-16	Screw, Sems , #6 x 1	6	
52	088-202241	Terminal Strip	1	TS-15
53	008-006149	Standoff Insulator	2	
54	004-200522	Washer, Fibre, #6, 5/16 in. od	4	
55	406-011312-03	Screw, Machine, #2-56 x 3/16	6	
56	004-002450	Washer, Fibre, #6, 9/16 in. od	1	
57	088-002235	Terminal Strip	2	TS-12, TS-9
58	088-200344	Terminal Strip	2	TS-4, TS-13
59	088-200312	Terminal Strip	1	TS-14
60	426-003543	Washer, Flat, #6	8	
61	088-301146	Terminal Strip	3	TS-1, TS-2, TS-8
62	076-200397	Lock, Line Cord	1	
63	006-000947	Socket, Tube, 9-pin miniature	3	XV1, XV3, XV4
64	088-200305	Terminal Strip	1	TS-3
65	076-100009	Plate Cap	1	
66	088-200292	Terminal Strip	2	TS-11, TS-7
67	088-200287	Terminal Strip	1	TS-10
68	088-200352	Terminal Strip	1	TS-6
69	088-002411	4-Connector Board	1	
70	006-000948	Socket, Tube, 8 pin octal	1	XV2
71	088-200384	Terminal Strip	1	TS-5
72	039-000613	Pilot Lamp, Neon	1	LM1
73	083-000782	Skirt, Plate Loading and Plate Tuning	2	

ITEM NO.	PART NUMBER	DESCRIPTION	QTY	REF SYMBOL
74	031-003739	Label, Tube Location	1	
75	031-003738	Label, Power Consumption	1	
75A	031-200433	Label, License	1	
76	047-100439	✓ Capacitor, Ceramic Disc, 47 mmf, 10%, 2KV	1	C26
77	047-100523	Capacitor, Ceramic Disc, 0.005 mfd, 20%, 1KV	1	C37
78	482-362472	Capacitor, Duramica, 4700 mmf, 5%, 500V	1	C1
79	481-152220	Capacitor, Duramica, 22 mmf, 5%, 300V	1	C2
80	482-262102	Capacitor, Duramica, 1000 mmf, 5%, 500V	1	C9
81	047-100224	Capacitor, Ceramic Disc, 0.01 mfd, +80-20%, 500V	1	C7
82	047-100442	Capacitor, Ceramic Disc, 0.005 mfd, 20%, 500V	10	C3, 8, 10, 11, 12, C13, 20, 23, 24, 39
83	047-100397	Capacitor, Ceramic Disc, 0.001 mfd, 3KV	1	C18
84	047-001397	Capacitor, Ceramic Disc, 100 mmf, 1000V	1	C35
85	047-001182	Capacitor, Ceramic Disc, 100 mmf, 500V	1	C29
86	047-200752	Capacitor, Ceramic Disc, 0.01 mfd, 1400V	1	C34 ✓ ✓ ✓ ✓ ✓
87	047-200230	Capacitor, Ceramic Disc, 0.001 mfd, 500V	9	C14, 27, 28, 33, 38 C40, 41, 42, 43
88	047-100395	Capacitor, Ceramic Disc, 0.002 mfd, 500V	2	C16, C21 ✓ ✓ ✓
89	047-101101	Capacitor, Ceramic Disc, 0.001 mfd, 1KV	5	C4, 5, 6, 30, 31
90	499-031104	Capacitor, Molded Paper, 0.1 mfd, 10%, 600V	1	C32
91	499-021474	Capacitor, Molded Paper, 0.47 mfd, 10%, 400V	1	C36

ITEM NO.	PART NUMBER	DESCRIPTION	QTY	REF SYMBOL
92	482-152330	Capacitor, Duramica, 33 mmf, 5%, 500V	1	C19
93	045-000723	Capacitor, Electrolytic, 40 mfd, 350V	4	C44,45, 46, 47
94	045-000619	Capacitor, Electrolytic, 100 mfd, 12V	1	C22
95	019-002634	Diode, Silicon, Type F6	2	CR1, CR2
96	019-301980	Diode, Germanium, type 1N295	1	CR3
97	053-000606	Choke, Output Plate, 0.425 MH	1	L13
98	051-003006	Coil, Interstage, 80 Meter	1	L3
99	051-003007	Coil, Interstage, 40 meter	1	L4
100	051-003008	Coil, Interstage, 20 meter	1	L5
101	051-003009	Coil, Interstage, 15 meter	1	L6
102	051-003010	Coil, Interstage, 10 meter	1	L7
103	051-003011	Coil, Interstage, 6 meter	1	L8
104	053-000598	Choke, Plate, 1.0 MH	1	L2
105	053-000597	Choke, Plate, 2.5 MH	1	L1
106	053-000599	Choke, Cathode, .33 MH	1	L12
107	053-000607	Choke, Line, 3.8 UH	2	L14, L15
108	451-252222	Resistor, Composition, 2.2K ohm, 10%, 1/2W	1	R22
109	451-252105	Resistor, Composition, 1 megohm, 10%, 1/2W	2	R8, R13
110	451-252472	Resistor, Composition, 4.7K ohm, 10%, 1/2W	2	R10, R12
111	451-252225	Resistor, Composition, 2.2 megohm, 10%, 1/2W	1	R14

ITEM NO.	PART NUMBER	DESCRIPTION	QTY	REF SYMBOL
112	451-252474	Resistor, Composition, 470K ohm, 10%, 1/2W	3	R15, R17, R19
113	451-252106	Resistor, Composition, 10 megohm, 10%, 1/2W	1	R18
114	451-252473	Resistor, Composition, 47K ohm, 10%, 1/2W	2	R1, R2
115	451-252104	Resistor, Composition, 100K ohm, 10%, 1/2W	1	R4
116	451-252102	Resistor, Composition, 1K ohm, 10%, 1/2W	1	R24
117	451-252563	Resistor, Composition, 56K ohm, 10%, 1/2W	1	R25
118	451-352332	Resistor, Composition, 3.3K ohm, 10%, 1W	1	R23
119	451-252101	Resistor, Composition, 100 ohm, 10%, 1/2W	1	R30
120	451-252471	Resistor, Composition, 470 ohm, 10%, 1/2W	1	R5
121	451-652102	Resistor, Composition, 1K ohm, 10%, 2W	1	R29
122	451-652223	Resistor, Composition, 22K ohm, 10%, 2W	3	R3, R6, R11
123	024-001356	Resistor, Wire Wound, 20 ohm, 10%, 7W	1	R26
124	024-001379	Resistor, Wire Wound, 10K ohm, 10%, 10W	2	R27, R28
125	024-001357	Resistor, Wire Wound, 2.5K ohm, 10%, 7W	1	R7
126	451-352104	Resistor, Composition, 100K ohm, 10%, 1W	1	R21
127	451-652183	Resistor, Composition, 18K ohm, 10%, 2W	1	R20
128	451-352393	Resistor, Composition, 39K ohm, 10%, 1W	1	R9
129	451-652470	Resistor, Composition, 47 ohm, 10%, 2W	1	Part of L11
130	033-100275	Solder	144 in.	

ITEM NO.	PART NUMBER	DESCRIPTION	QTY	REF SYMBOL
131	087-100960	Cable, Coaxial, RG-58/U	7-1/2 in.	
132	087-105313	Cable, Coaxial, Red	9 in.	
133	087-104930	Wire, #22, White and Black	20 in.	
134	087-100709	Wire, #14, Solid, Bare	10 in.	
135	087-100723	Wire, #22, Solid, Bare	50 in.	
136	065-200405	Sleeving	72 in.	
137	087-104122	Wire, #22, Violet	10 in.	
138	087-104120	Wire, #22, Green	10 in.	
139	087-104115	Wire, #22, Black	20 in.	
140	087-104124	Wire, #22, White	30 in.	
141	087-104121	Wire, #22, Blue	10 in.	
142	087-104117	Wire, #22, Red	40 in.	
143	031-003725	Tag, Serial and Registration	1	
144	094-902601	Assembly and Operating Manual	1	
145	087-006484	Wiring Harness (Front)	1	WH-1
146	087-006485	Wiring Harness (Rear)	1	WH-2
147	068-001120	Panel		



2 x 3/16



4 x 5/16



6 x 5/16



6 x 3/8

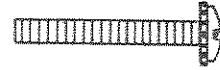

6 x 1

MACHINE
SCREW

SEMS
SCREWS



4 x 1/4



6 x 1/4



6 x 1/4



8 x 3/16



6-5/16

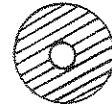

6-9/16

FLAT HEAD
SCREWS

THREAD FORMING
SCREW

SET
SCREW

FIBRE
WASHERS



6



3/8

FLAT
WASHERS



4

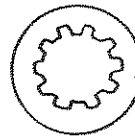

3/8

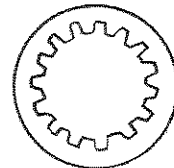

1/2

INTERNAL TOOTH
LOCKWASHERS



4



3/8

HEX
NUT



6

KEP
NUT



3/8

PALNUT



6
SOLDER LUG



STANDOFF
INSULATOR



SPACER
(CAPACITOR
MOUNTING)

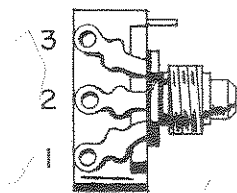

MIKE GAIN CONTROL

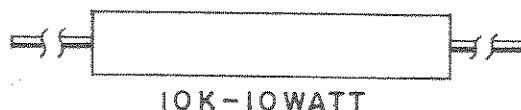

2.5K OHM 7 WATT

RESISTORS

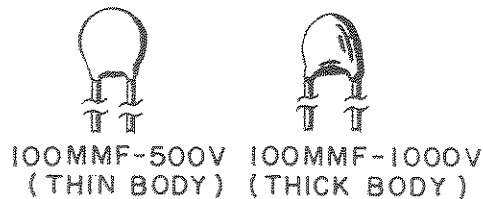
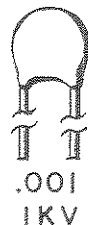
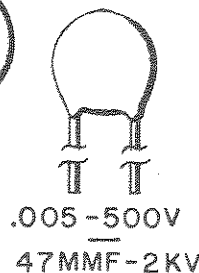
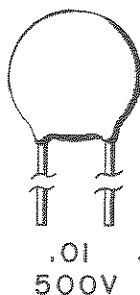
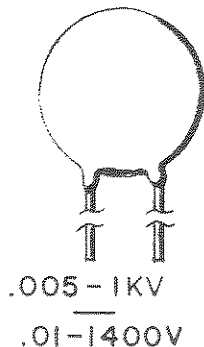
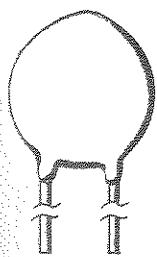

CERAMIC DISC CAPACITORS

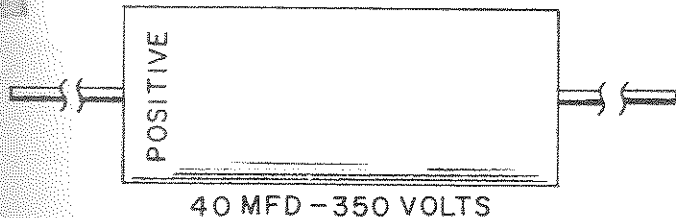

ELECTROLYTIC CAPACITORS

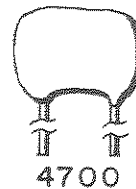

DURAMICA CAPACITORS

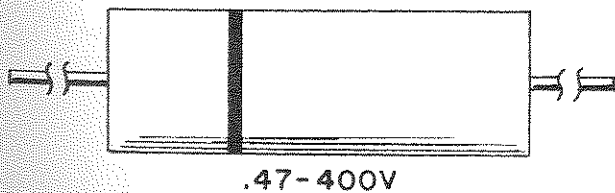

MOLDED PAPER CAPACITORS



SILICON DIODE TYPE F6



TYPES OF GERMANIUM DIODES TYPE IN295

DIODES

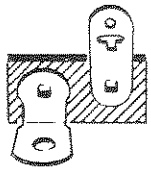

TS-5

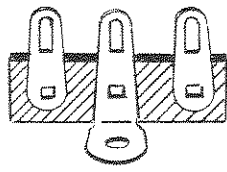

TS-16, TS-17, TS-18

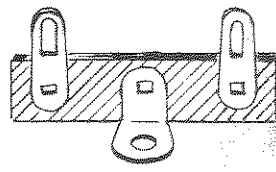

TS-11, TS-7

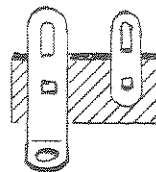

TS-6

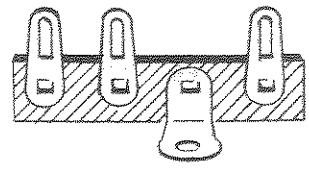

TS-3

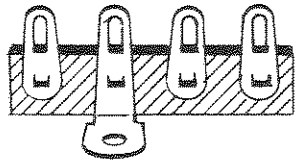

TS-1, TS-2, TS-8

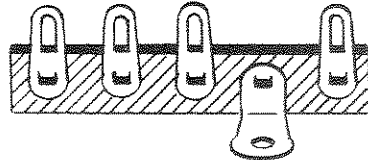

TS-14

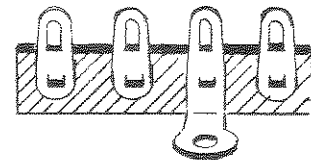

TS-12, TS-9

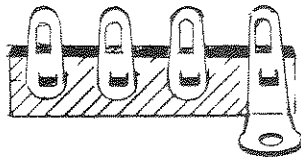

TS-4, TS-13

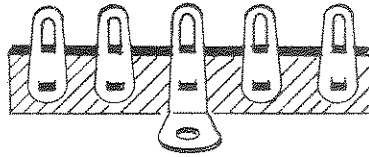

TS-10

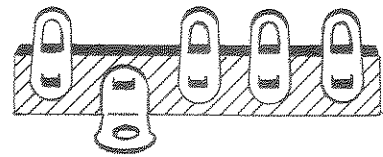

TS-15

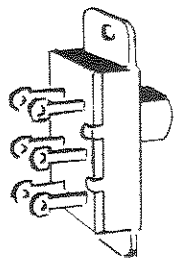

S4
DPDT

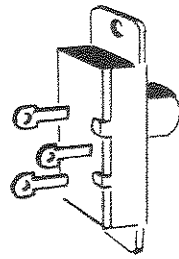

S1
SPDT

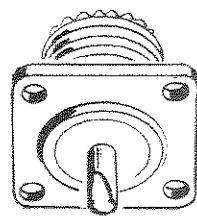

ANTENNA
CONNECTOR

J5

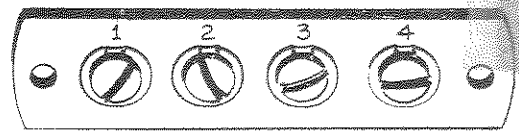

4-CONNECTOR BOARD



LINE CORD LOCK

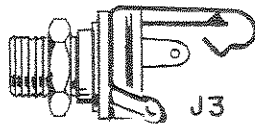

KEY JACK

J3



PILOT LAMP
MOUNTING CLIP



PILOT
LAMP

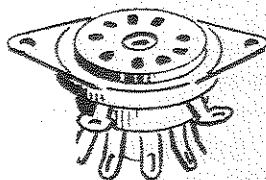

9-PIN MINIATURE
SOCKET

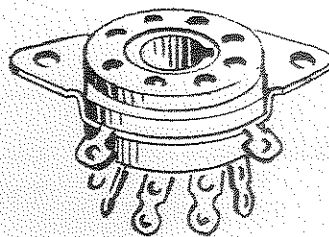

8-PIN OCTAL
SOCKET



MICROPHONE
CONNECTOR

J4



PIN JACK
(RED & BLACK)

J1, J2

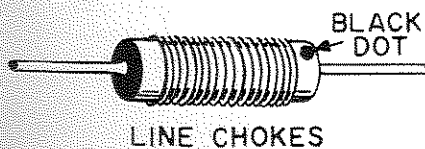
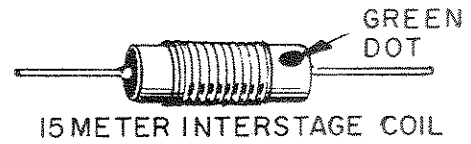
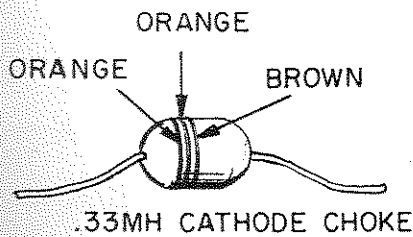
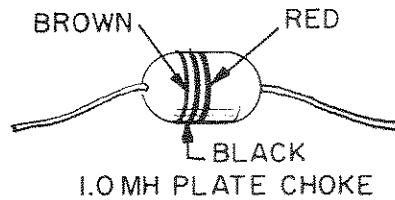
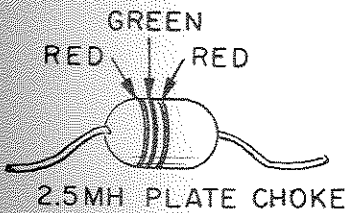
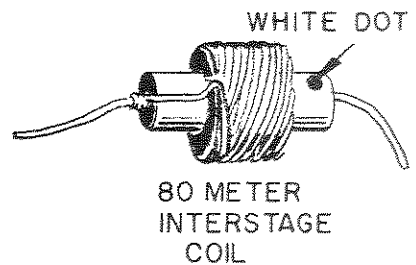
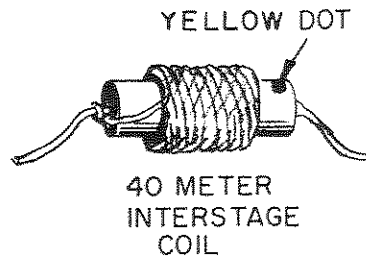
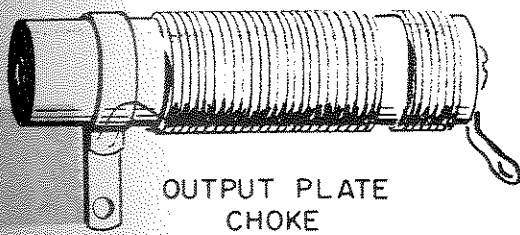
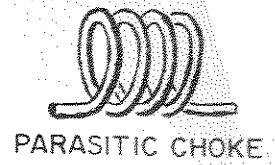
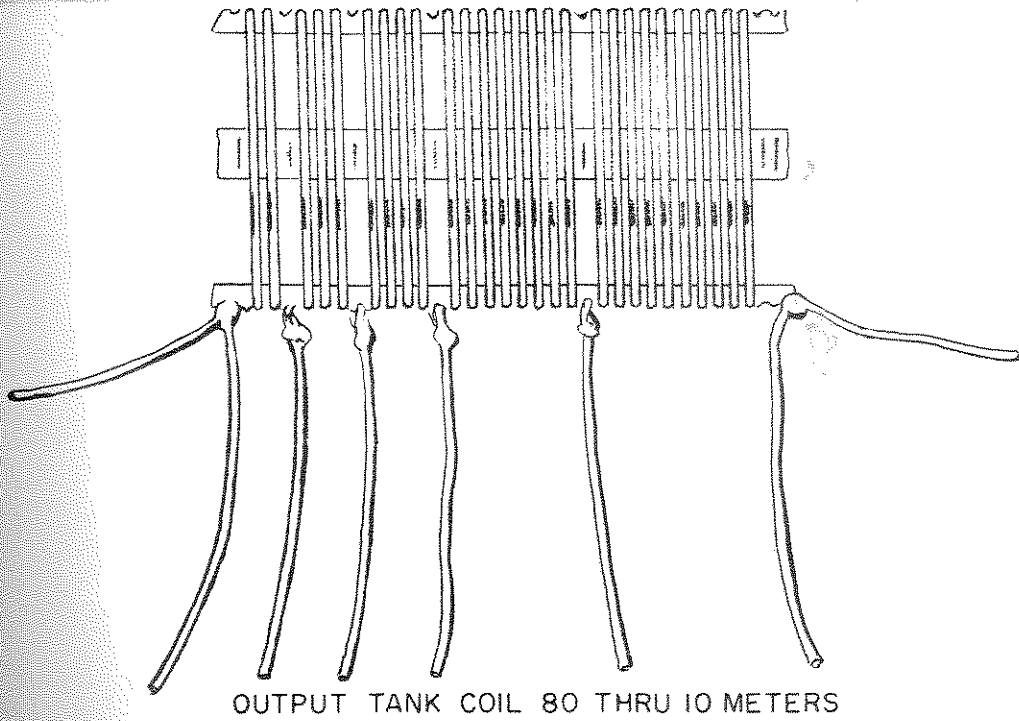

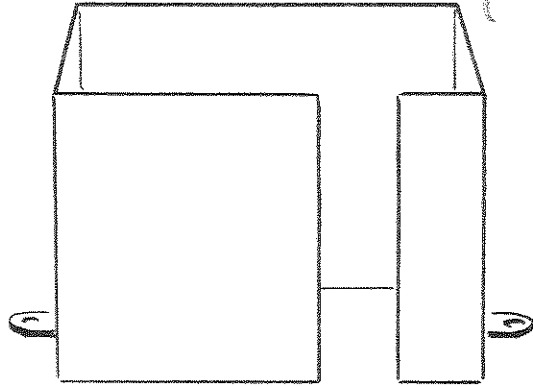

BANDSWITCH SHIELD

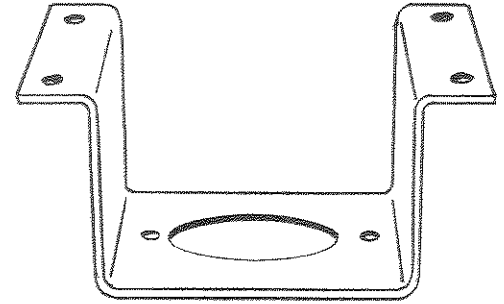

TUBE BRACKET

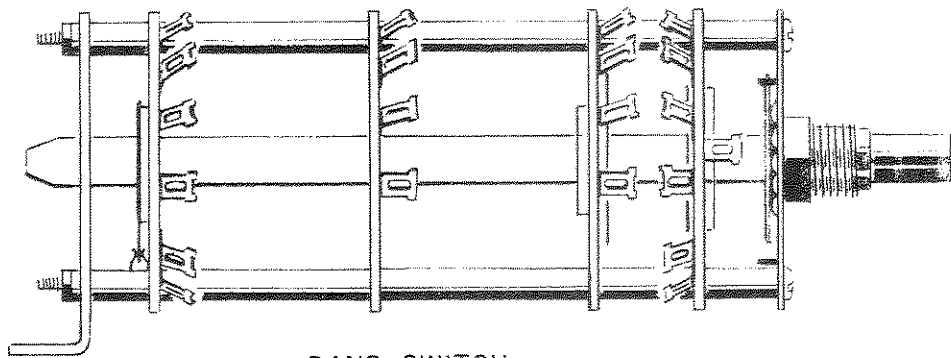

BAND SWITCH

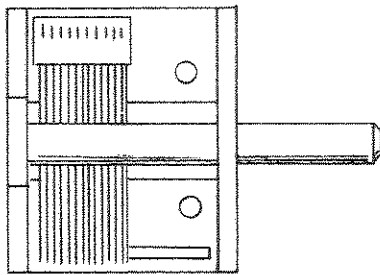

DRIVE CAPACITOR

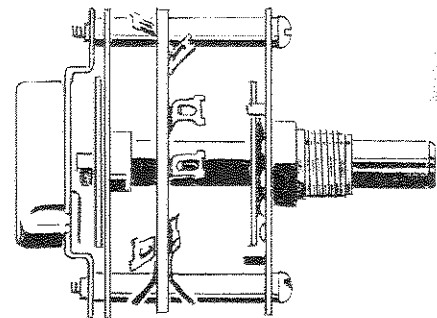

FUNCTION SWITCH

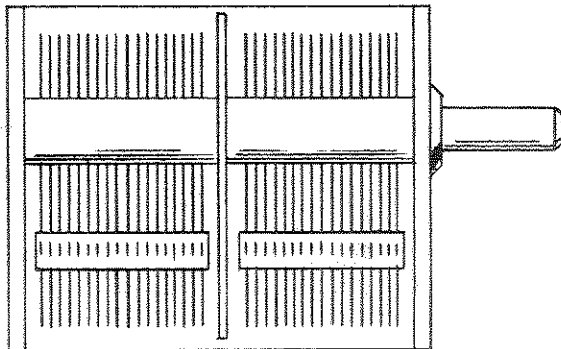

PLATE LOADING CAPACITOR

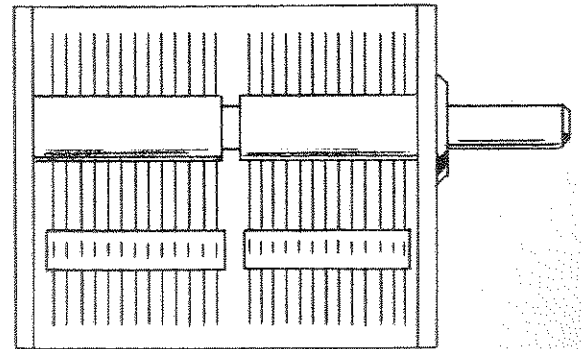
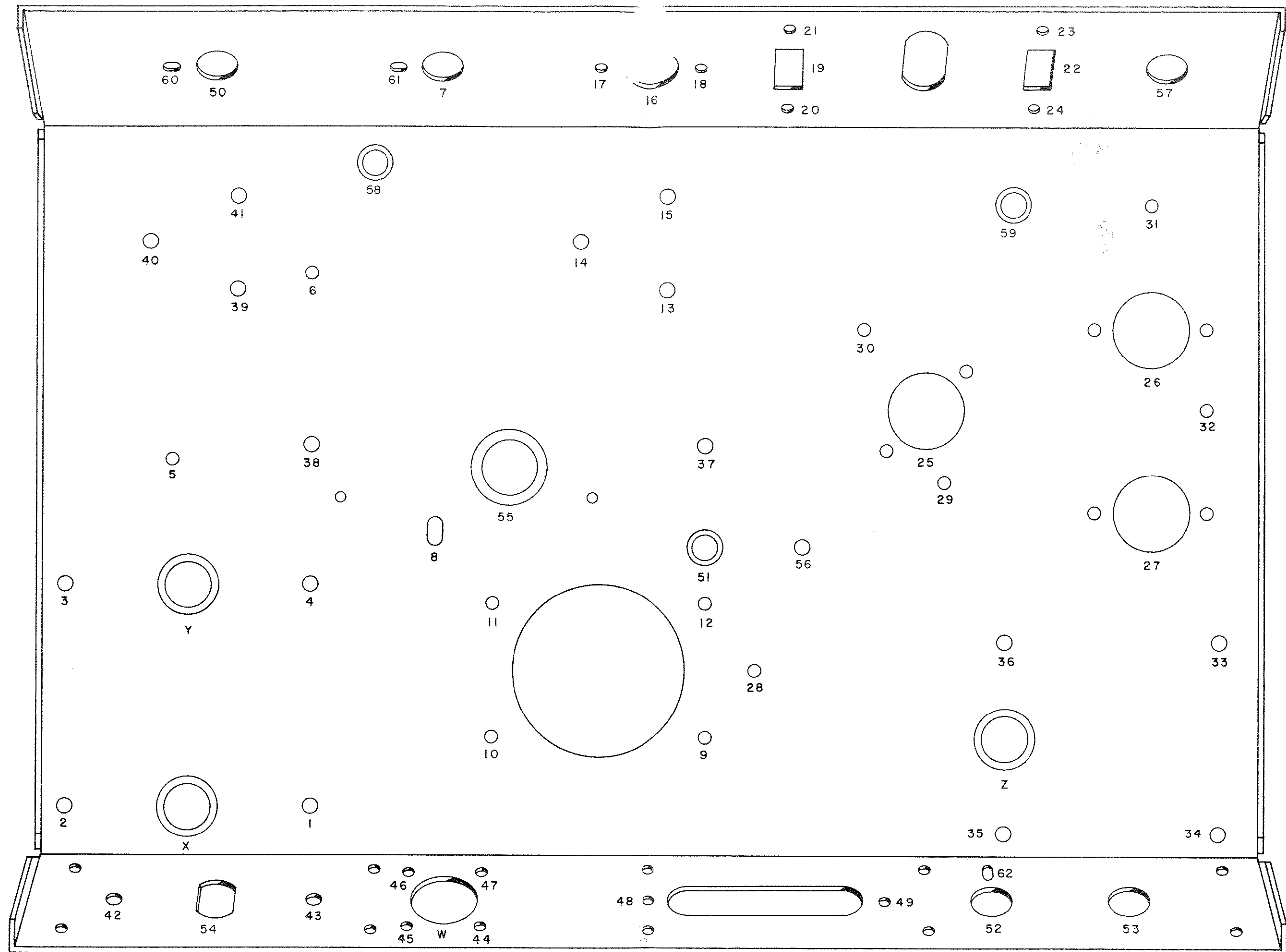
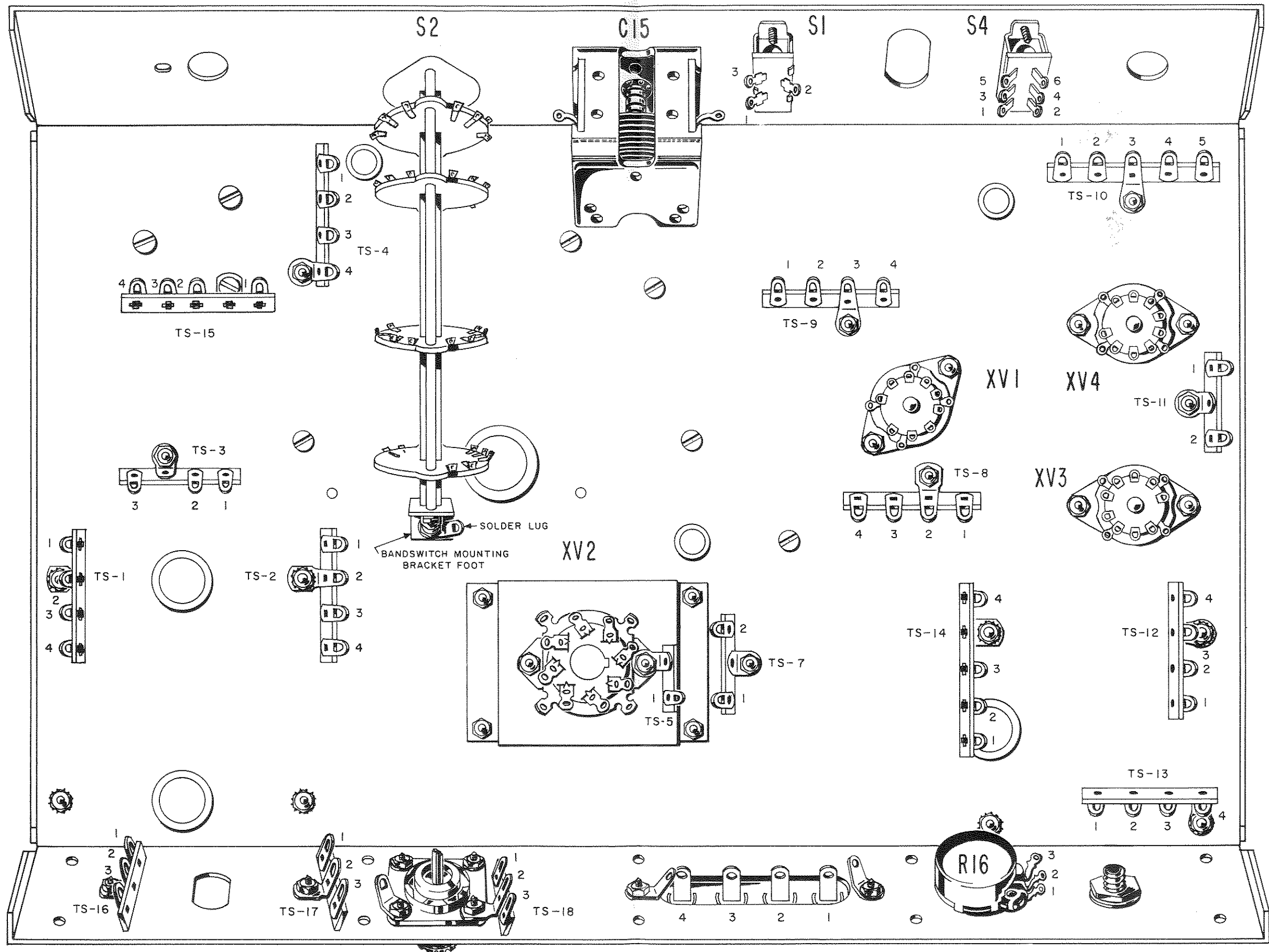

PLATE TUNING CAPACITOR



Pictorial 1. Chassis Numbering Sequence.



Pictorial 2. Mounting of Components And Orientation on Chassis Bottom.

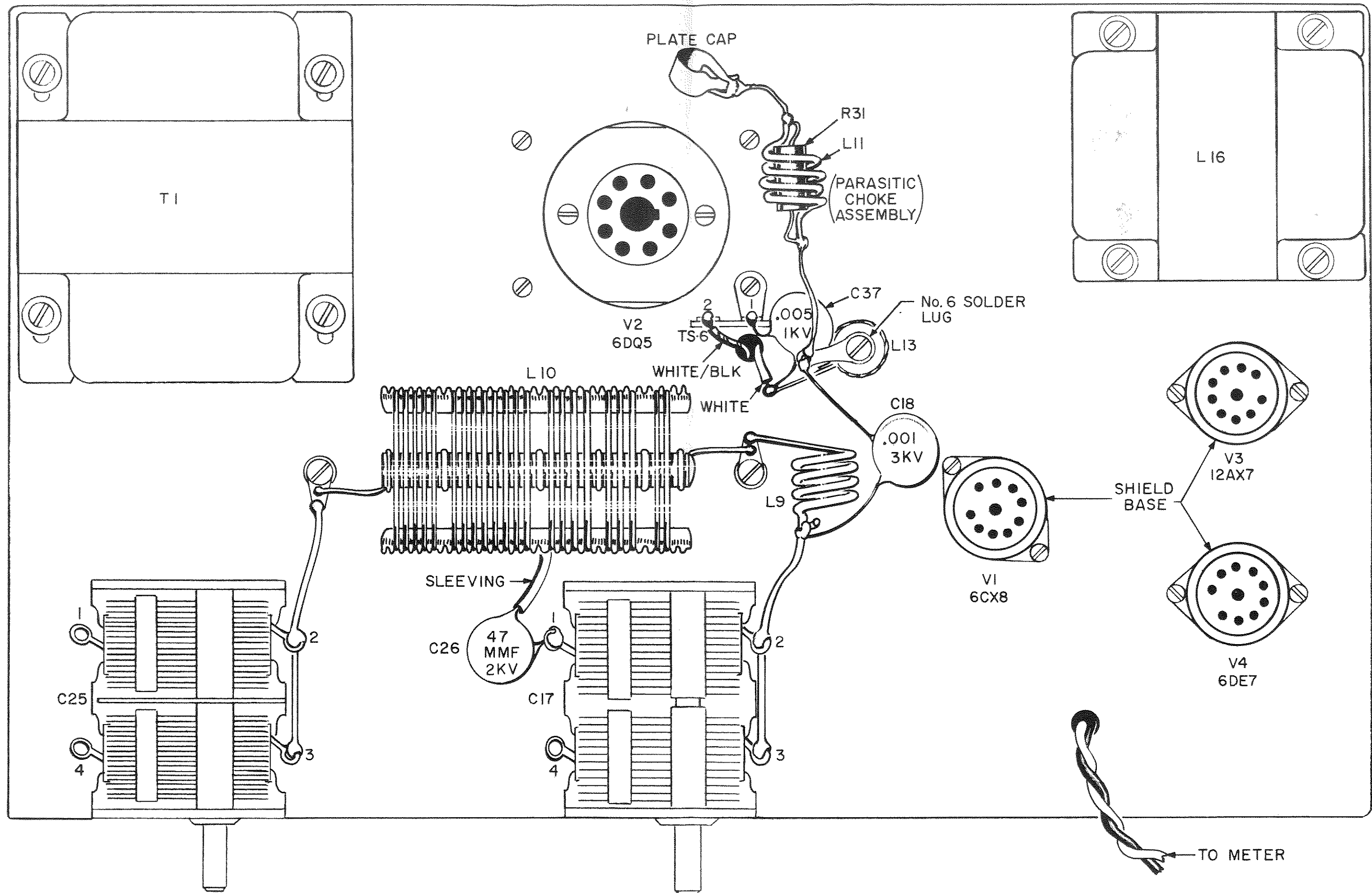

Pictorial 3. Mounting of Components and Orientation on Chassis Top.

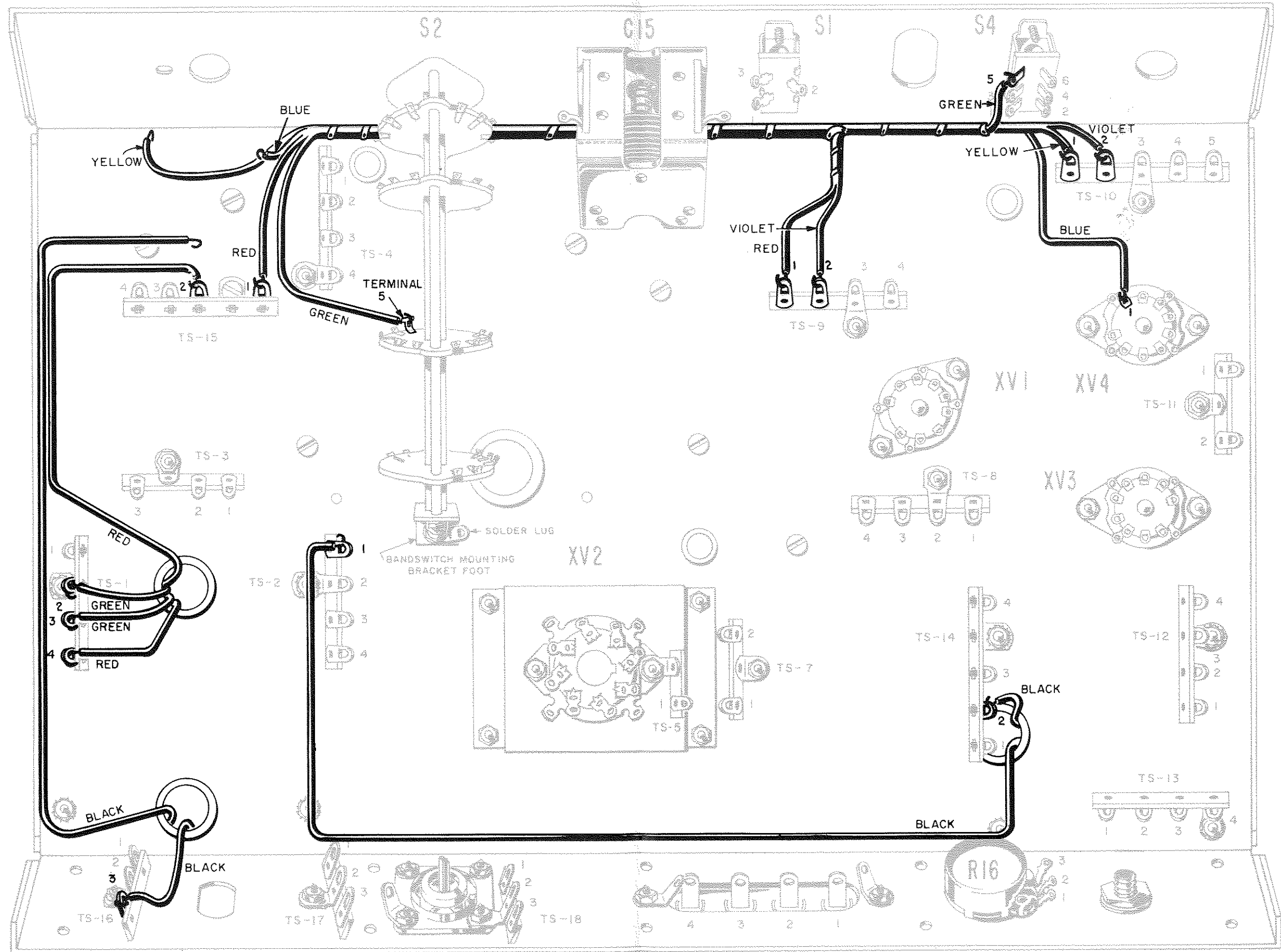

Pictorial 4. Installation of Front Cable Harness WH-1.

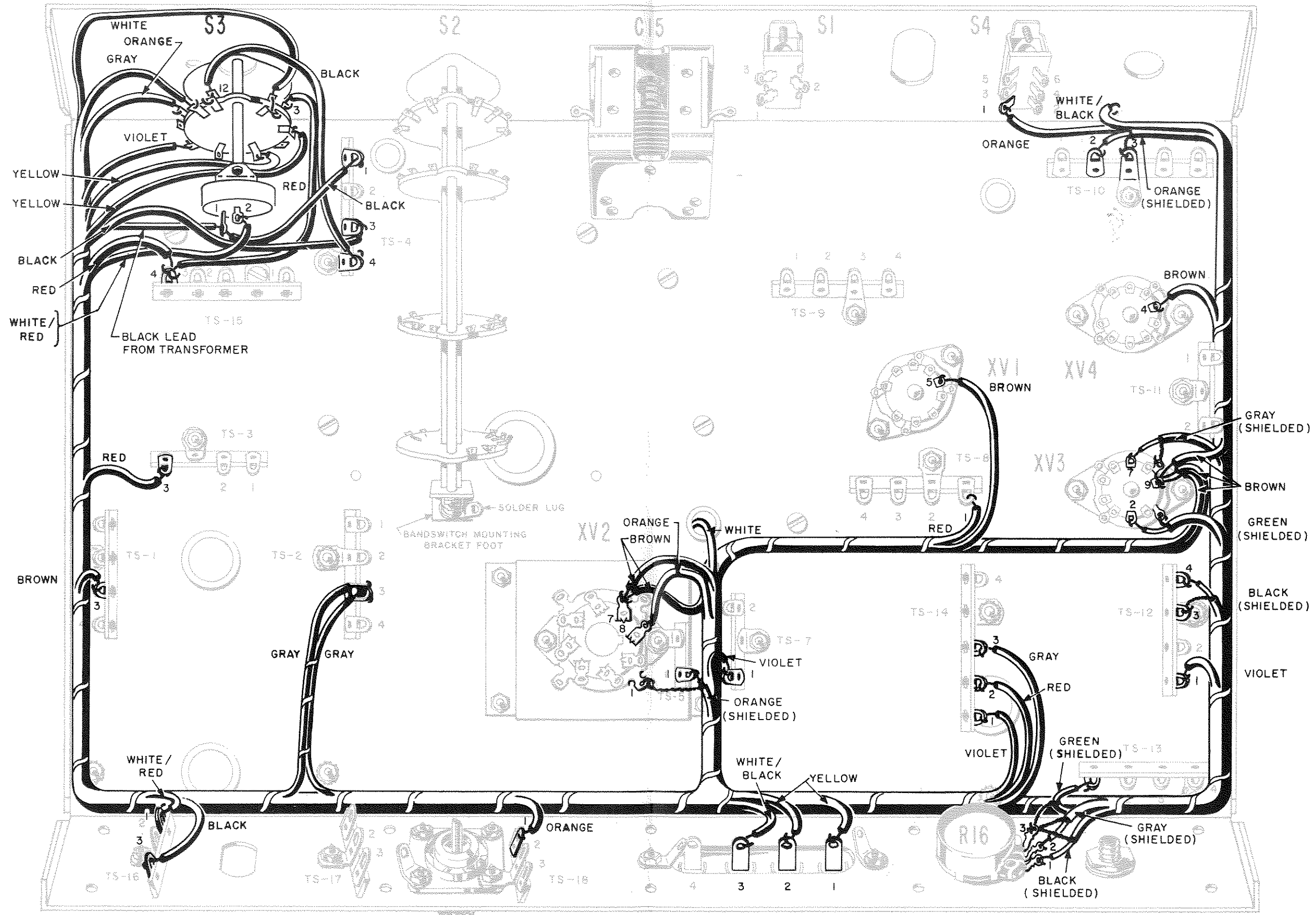

Pictorial 5. Installation of Rear Cable Harness WH-2.

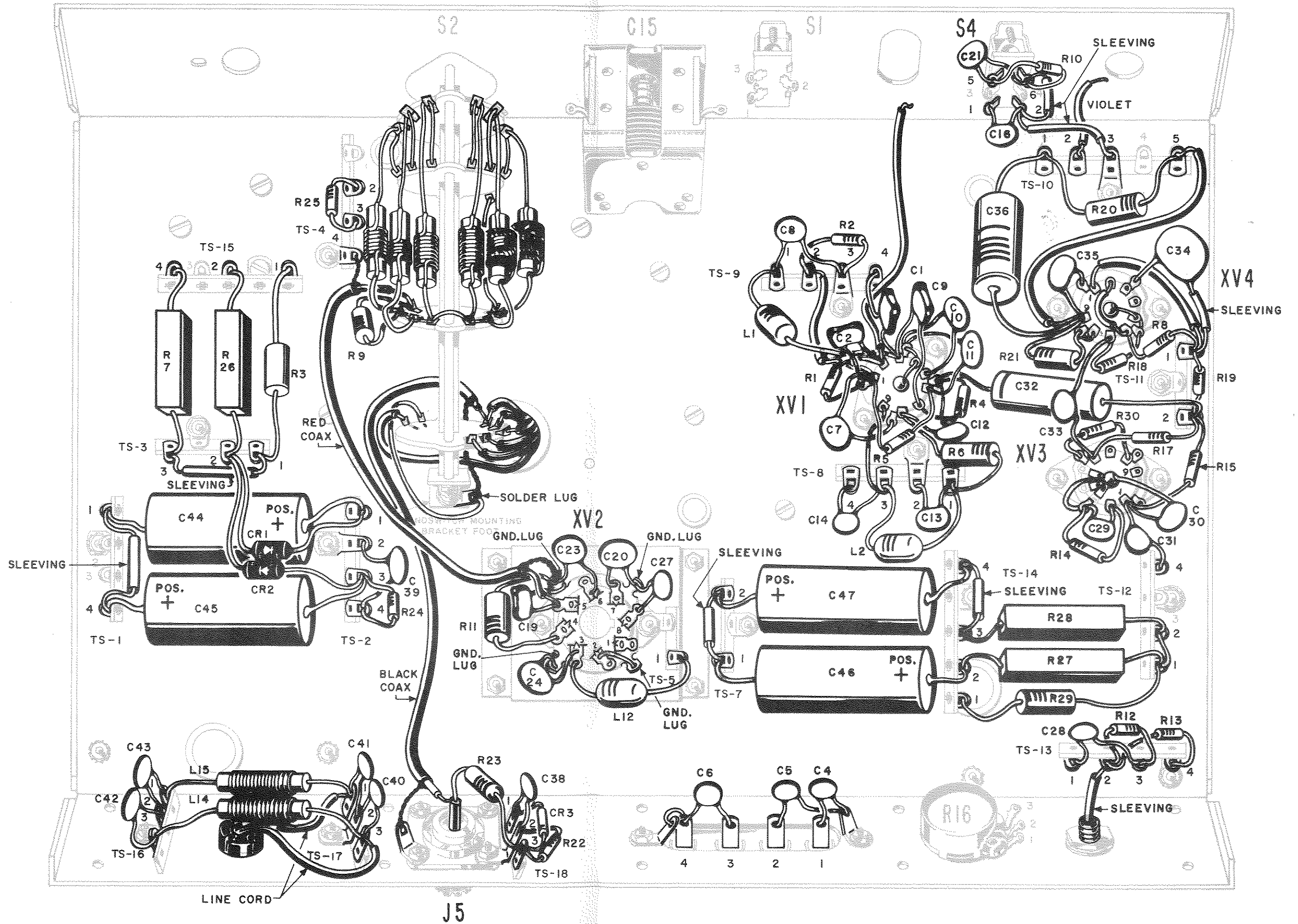

Pictorial 6. Wiring of Components.

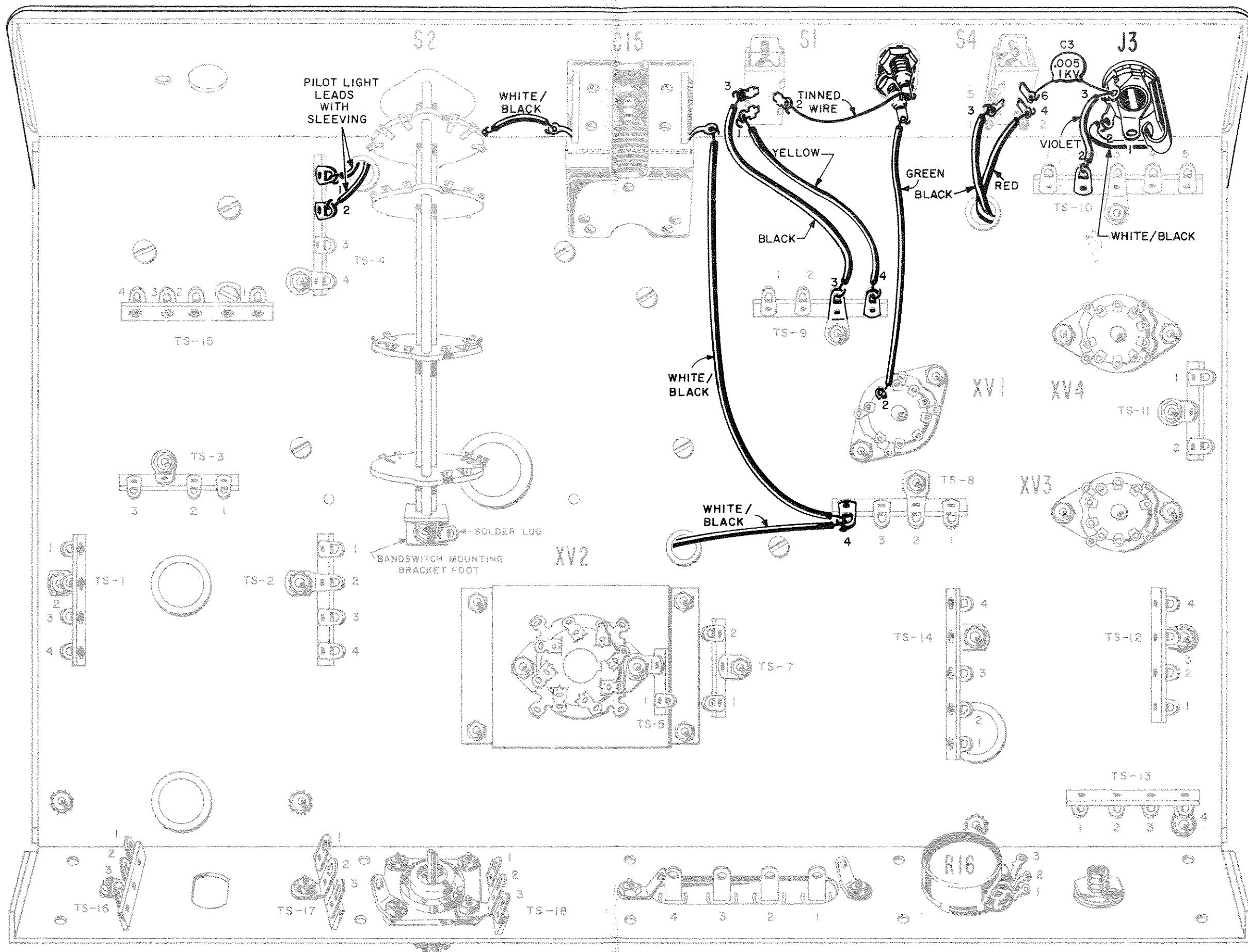

Pictorial 7. Wiring Components of Front Panel.