

HEATHKIT[®] MANUAL

for the
MODEL DX-100
TRANSMITTER

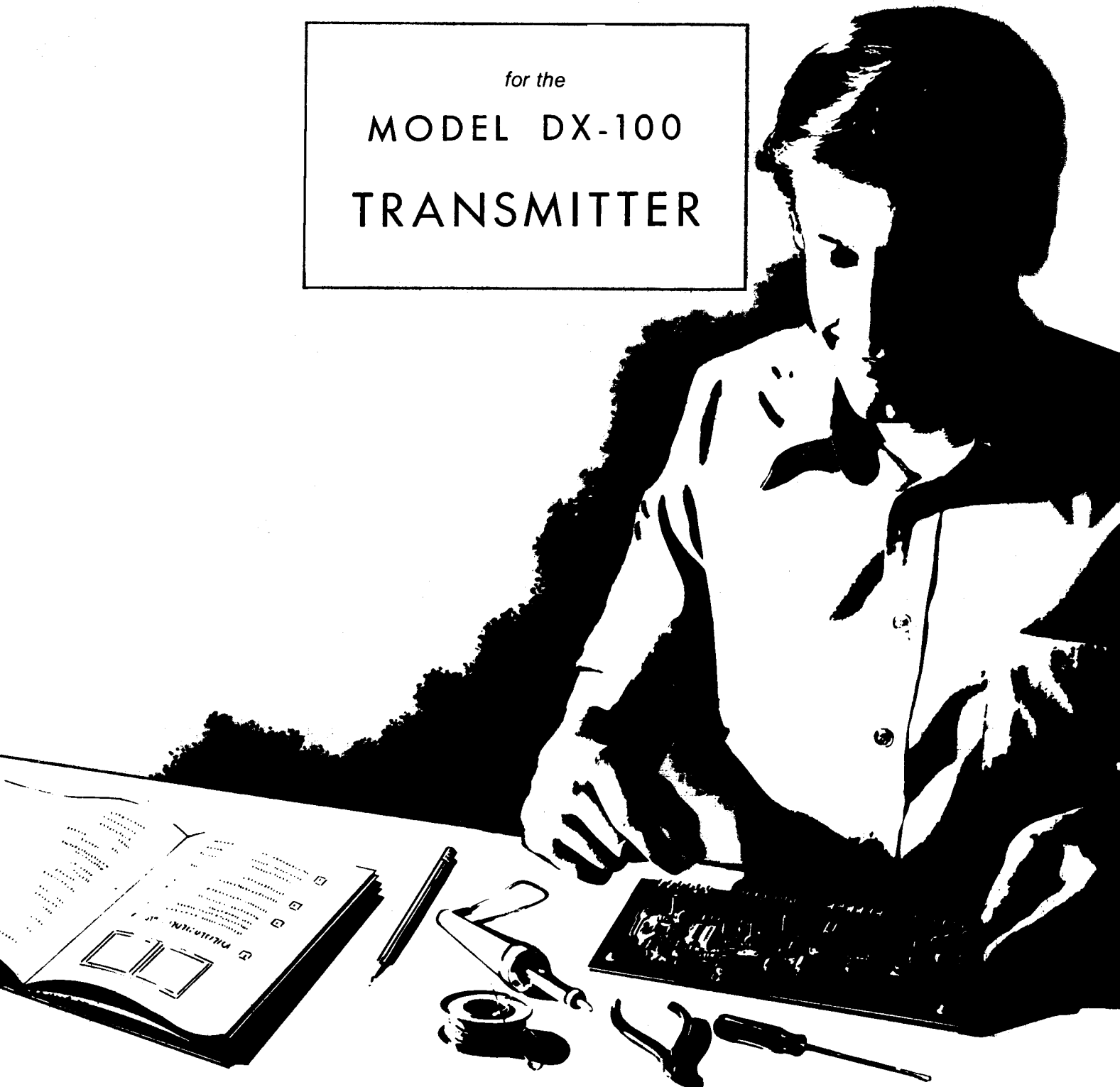

HEATH COMPANY • BENTON HARBOR, MICHIGAN

HEATH COMPANY PHONE DIRECTORY

The following telephone numbers are direct lines to the departments listed:

Kit orders and delivery information (616) 982-3411
Credit (616) 982-3561
Replacement Parts (616) 982-3571

Technical Assistance Phone Numbers

8:00 A.M. to 12 P.M. and 1:00 P.M. to 4:30 P.M., EST, Weekdays Only
R/C, Audio, and Electronic Organs (616) 982-3310
Amateur Radio (616) 982-3296
Test Equipment, Weather Instruments and
Home Clocks (616) 982-3315
Television (616) 982-3307
Aircraft, Marine, Security, Scanners, Automotive,
Appliances and General Products (616) 982-3496
Computers (616) 982-3309

YOUR HEATHKIT 90-DAY LIMITED WARRANTY

Consumer Protection Plan for Heathkit Consumer Products

Welcome to the Heath family. We believe you will enjoy assembling your kit and will be pleased with its performance. Please read this Consumer Protection Plan carefully. It is a "LIMITED WARRANTY" as defined in the U.S. Consumer Product Warranty and Federal Trade Commission Improvement Act. This warranty gives you specific legal rights, and you may also have other rights which vary from state to state.

Heath's Responsibility

PARTS — Replacements for factory defective parts will be supplied free for 90 days from date of purchase. Replacement parts are warranted for the remaining portion of the original warranty period. You can obtain warranty parts direct from Heath Company by writing or telephoning us at (616) 982-3571. And we will pay shipping charges to get those parts to you . . . anywhere in the world.

SERVICE LABOR — For a period of 90 days from the date of purchase, any malfunction caused by defective parts or error in design will be corrected at no charge to you. You must deliver the unit at your expense to the Heath factory, any Heathkit Electronic Center (units of Veritechnology Electronics Corporation), or any of our authorized overseas distributors.

TECHNICAL CONSULTATION — You will receive free consultation on any problem you might encounter in the assembly or use of your Heathkit product. Just drop us a line or give us a call. Sorry, we cannot accept collect calls.

NOT COVERED — The correction of assembly errors, adjustments, calibration, and damage due to misuse, abuse, or negligence are not covered by the warranty. Use of corrosive solder and/or the unauthorized modification of the product or of any furnished component will void this warranty in its entirety. This warranty does not include reimbursement for inconvenience, loss of use, customer assembly, set-up time, or unauthorized service.

This warranty covers only Heath products and is not extended to other equipment or components that a customer uses in conjunction with our products.

SUCH REPAIR AND REPLACEMENT SHALL BE THE SOLE REMEDY OF THE CUSTOMER AND THERE SHALL BE NO LIABILITY ON THE PART OF HEATH FOR ANY SPECIAL, INDIRECT, INCIDENTAL OR CONSEQUENTIAL DAMAGES, INCLUDING BUT NOT LIMITED TO ANY LOSS OF BUSINESS OR PROFITS, WHETHER OR NOT FORSEEABLE.

Some states do not allow the exclusion or limitation of incidental or consequential damages, so the above limitation or exclusion may not apply to you.

Owner's Responsibility

EFFECTIVE WARRANTY DATE — Warranty begins on the date of first consumer purchase. You must supply a copy of your proof of purchase when you request warranty service or parts.

ASSEMBLY — Before seeking warranty service, you should complete the assembly by carefully following the manual instructions. Heathkit service agencies cannot complete assembly and adjustments that are customer's responsibility.

ACCESSORY EQUIPMENT — Performance malfunctions involving other non-Heath accessory equipment, (antennas, audio components, computer peripherals and software, etc.) are not covered by this warranty and are the owner's responsibility.

SHIPPING UNITS — Follow the packing instructions published in the assembly manuals. Damage due to inadequate packing cannot be repaired under warranty.

If you are not satisfied with our service (warranty or otherwise) or our products, write directly to our Director of Customer Service, Heath Company, Benton Harbor MI 49022. He will make certain your problems receive immediate, personal attention.

HEATHKIT TRANSMITTER

MODEL DX-100



SPECIFICATIONS

RF Power Output.....	100-125 watts phone, 120-140 watts CW
Output Impedance.....	50-600 Ω (non-reactive)
Output Coupling.....	Pi network (coaxial)
Operation.....	Crystal-VFO, CW-Phone, Local-Remote
Band Coverage.....	160, 80, 40, 20, 15, 11, 10
Audio Output.....	85 watts at 300-3000 cycles
Tube Complement:	
Power Section.....	6AL5 bias rectifier 5V4 low voltage rectifier 2 - 5R4GY high voltage rectifier OA2 regulator
Audio Section.....	12AX7 speech amplifier 12BY7 audio driver 2 - 1625 modulator
RF Section.....	6AU6 VFO 12BY7 crystal oscillator-buffer 5763 driver 2 - 6146 parallel power amplifier 6AQ5 clamp
Power Requirements.....	115 volts AC, 50 to 60 cycles
Standby.....	150 watts
CW.....	400 watts (intermittent)
Phone.....	450-600 watts
Cabinet Size.....	20 7/8" wide x 13 3/4" high x 16" deep
Net Weight.....	100 lbs.
Shipping Weight.....	107 lbs.

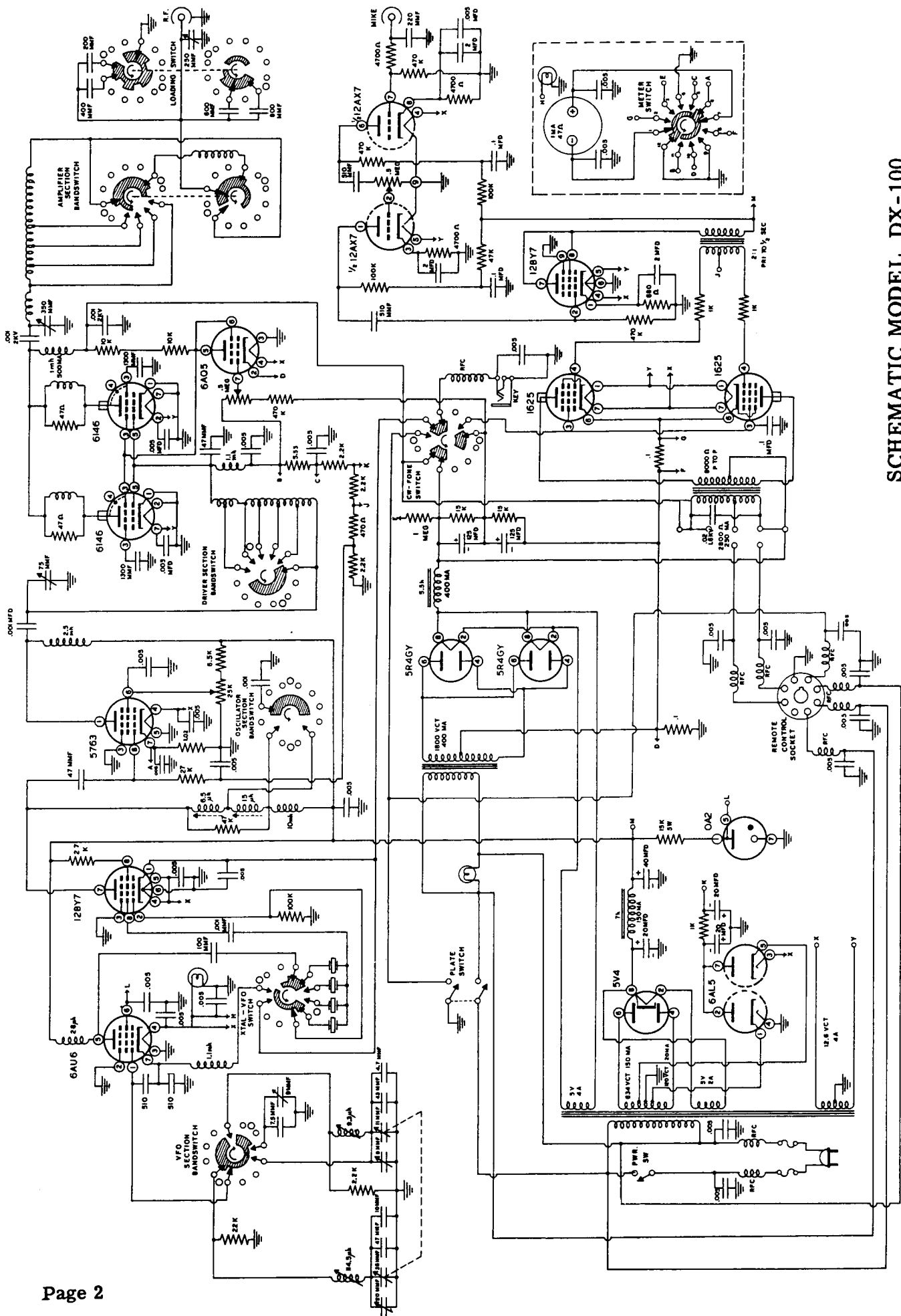

SCHEMATIC MODEL DX-100

INTRODUCTION

The Heathkit model DX-100 Transmitter represents the complete transmitting complement of the amateur operator station. The only external requirements are an antenna, ground and key or microphone. Panel controls allow VFO or crystal control, Phone or CW operation on all amateur bands up to 30 mc. The DX-100 includes three power supplies, low voltage, high voltage and fixed bias, four radio frequency stages and four audio stages.

The pi network output coupling tends to suppress harmonics and will match a wide range of antenna impedance. The original Heath VFO has been redesigned for use in the DX-100. The use of air trimmer capacitors, relocation of temperature compensating elements and tighter shielding, have improved the stability and operating characteristics. Panel controls include key and microphone connections, audio gain, crystal-VFO switch, drive control, bandswitch, fine and coarse loading controls, phone-CW switch, VFO tuning, driver tuning, final tuning, power and plate switches. A socket on the rear of the transmitter is so connected to allow remote control of the transmitter or to operate an antenna relay. It also makes 80 watts of audio at 500 Ω available for driving larger modulators or for public address work.

The following block diagram and circuit description will give the builder a better understanding of the transmitter. This knowledge is an invaluable aid to construction and as such, is well worth reading thoroughly.

IN A TRANSMITTER OF THIS SIZE, LETHAL VOLTAGES ARE PRESENT. CONSEQUENTLY GREAT CARE MUST BE EXERCISED WHEN ANY TESTS OR ADJUSTMENTS ARE MADE.

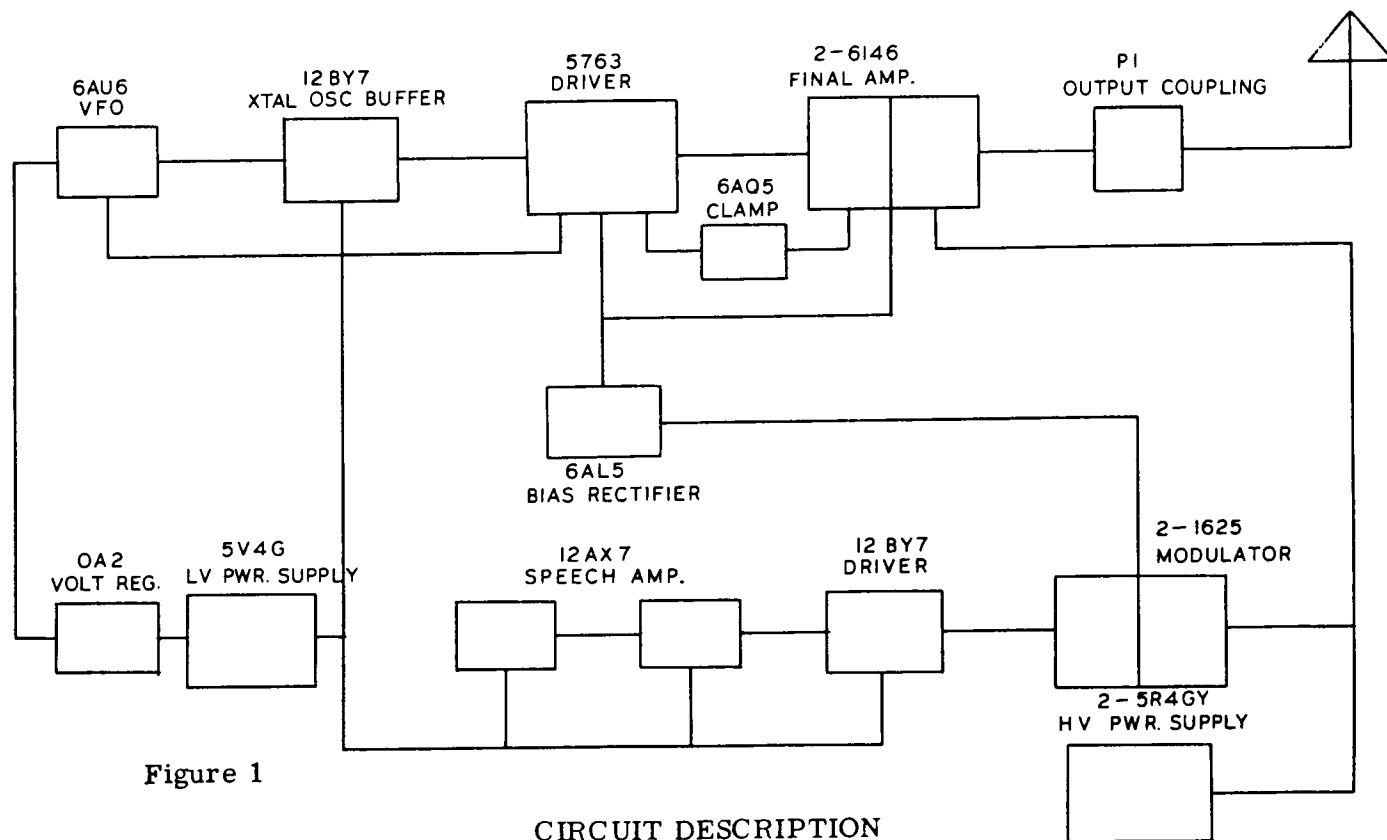

Figure 1

CIRCUIT DESCRIPTION VFO

The VFO circuit consists of a 6AU6 tube operating as a Clapp oscillator in the frequency ranges of 1750 to 2000 kc, 7000 to 7425 kc and 6740 to 6807.5 kc. To prevent undue heating effects, the tube is mounted on top and outside of the VFO enclosure. All the frequency determining components are mounted rigidly inside the shielded enclosure. A double bearing ceramic insulated tuning capacitor of the differential type is used as a frequency control. The differential capacitor having two stator assemblies of different capacity, permits a large bandwidth at high frequencies as well as the lower frequencies. Ceramic insulated air trimmers prevent initial drift during calibration.

The coils are wound with Litz or double cellulose wire on heavy ceramic forms, doped with Q-max and baked. This combination achieves high Q, low drift and decreases the effect of humidity. Temperature compensating capacitors mounted in close proximity to the coils decrease slightly in capacity as the coil inductance increases with heating. The capacitors tend to raise the frequency and the inductances tend to lower the frequency. By properly proportioning these components, the effects of one cancel the other and the frequency remains constant. The VFO switch is mounted vertically inside the compartment and operated by an interrupted switching mechanism on the band switch. This correlates the VFO output frequency with the band in use.

The Clapp or series-tuned Colpitts oscillator circuit presents a very low impedance at resonance for the tube grid to look into. This minimizes the effect of shift in tube capacitance upon the output frequency. A large capacitive voltage divider necessary for operation of the Colpitts circuit, also lessens the effect of tube capacitance upon frequency. The 6AU6 tube is also operating as an electron-coupled oscillator, wherein the tube screen grid operates as the oscillator plate. The screen grid voltage is stabilized at 150 volts by an OA2 regulator in the power supply. With the screen grid operating as the oscillator plate, the actual tube plate is coupled to the oscillator only by the electron stream in the tube and further shielded from the oscillator by the grounded suppressor grid. This effectively isolates the oscillator circuit from the following stages and lessens the effect of loading on the VFO frequency. The output of the VFO is broadbanded and fed to one position of the XTAL-VFO switch. This switch also opens the cathode circuit of the 6AU6 when in any crystal position, thus disabling the VFO when using crystal control.

CRYSTAL OSCILLATOR-BUFFER

A 12BY7 tube is used as a modified Pierce crystal oscillator. This circuit is basically a grounded cathode Colpitts oscillator with the grid-cathode and screen-cathode capacities serving as the capacity voltage divider. In the first four positions of the XTAL-VFO switch, crystals are connected between the grid and screen of the 12BY7. In the fifth position, the VFO output is connected between grid and ground of the 12BY7 and the VFO cathode is connected to the cathode of the 12BY7. The cathodes of both tubes are then directed to either the key jack or one-half of the plate power switch by means of the CW-PHONE switch. The plate circuit of the 12BY7 is untuned when operating 160 or 80 meters, slug tuned to 40 meters for operation at 40, 20 or 15, meters and slug tuned to 20 meters when operating in the 10-11 meter band. An untuned RF choke and the two slug-tuned coils are in series from B+ to the tube plate. One section of the band switch shorts out the coils not being used for a given band. The output of the 12BY7 is capacity coupled to the 5763 driver stage.

DRIVER STAGE

A 5763 tube operating with a combination of fixed and automatic bias, is used to drive the final amplifier. As the stage has plate voltage supplied and the cathode circuit closed, sufficient bias is necessary to keep it from drawing plate current during key up or standby conditions. The additional automatic bias establishes the operating bias during "key down" condition. A meter shunt resistor is permanently connected in the cathode circuit and the meter switched across it when reading driver current. The resistance of the shunt is such as to cause the meter to read 50 milliamperes full scale. Potentiometer control of the driver screen voltage allows control of the grid drive to the final amplifier. The plate circuit of the 5763 is shunt fed through an RF choke. Pi network interstage coupling is used between the driver and a final amplifier with the input capacitor of the pi section variable and the output capacitor fixed. The pi section inductance is tapped and the proper tap for each band selected by a section of the band switch. The use of pi network interstage coupling helps reduce the harmonic output of the transmitter. The fixed output capacitor of the pi interstage coupling appears from grid to ground of the final amplifier and shorts out the higher frequency harmonics.

FINAL AMPLIFIER

Two 6146 tubes operating at approximately 740 volts are used as the power amplifier. Here also, a combination of fixed and automatic bias is used to establish the operating and standby condition. In addition to the fixed bias, the screens of the tubes are clamped by a 6AQ5. The action of the clamp tube is as follows:

The screen voltage to the 6146's is obtained through a dropping resistor from the plate supply and the 6AQ5 tube plate is connected at the 6146 screen. The 6AQ5 cathode is grounded and its grid is common to the grid circuit of the 6146 stage. As long as grid excitation is obtained from the preceding stage, the bias developed keeps the clamp tube cut off and it does not draw current. If excitation is lost, the 6AQ5 grid goes to zero and the tube draws heavy current, dropping the voltage to the 6146 screen to a very low value, thus further protecting the 6146 stage. The fixed bias applied to the grids of the 6146 stage would normally keep the 6AQ5 cut off also, regardless of loss of excitation. Consequently, a sufficient positive voltage is applied to the 6AQ5 grid to just balance the fixed bias but not the operating bias. This allows the clamp tube to be cut off by the operating bias only.

The tank circuit of the 6146 stage is pi coupled to the antenna, using a 350 $\mu\mu\text{f}$ variable capacitor on the input side, a tapped inductance operating from the band switch and a variable capacitor with additional fixed capacitors on the output. A unique switching system with four fixed capacitors of 200, 400, 600 and 800 $\mu\mu\text{f}$ form combinations of these capacities allowing the coarse loading control to switch from 0 to 2000 $\mu\mu\text{f}$ in 200 $\mu\mu\text{f}$ steps. A 250 $\mu\mu\text{f}$ variable capacitor as a fine loading control, fills the space between steps. This permits smooth control of the loading capacitor from 15 $\mu\mu\text{f}$ to 2250 $\mu\mu\text{f}$.

When modulating tetrode tubes, it is necessary to modulate the screen as well as the plate. This is accomplished by supplying the screen voltage through a dropping resistor from the plate voltage. The 6146 tubes are sub-mounted on a separate plate. This serves two purposes. The plate acts as a shield to isolate the 6146 grids from the output circuit and the sub-mounting forms a chimney effect causing air to flow up past the tubes for cooling.

AUDIO SECTION

Two triode stages of resistance coupled speech amplification are combined in a 12AX7 tube giving sufficient gain for a low level crystal or dynamic microphone. In amateur communications, it is desirable to sacrifice fidelity in favor of narrow bandwidth and confine the power transmitted to voice frequencies, a range of about 250 to 3000 cycles. To limit the low frequency response of the speech amplifier, the coupling condensers are small, 500 $\mu\mu\text{f}$. This presents a high reactance to the lower frequencies. The higher frequencies over 3000 cycles per second, are eliminated in the modulator stage.

The 12BY7 driver tube is triode connected to present a low impedance to the modulator grids. In class AB2 audio, the modulator grids draw current on positive peaks, consequently the driver stage must deliver power to the grids. By using a low impedance power source, less variation will result between times of load or no load, as the driver swings from positive to negative. The 12BY7 driver feeds the modulator grids through a 2 to 1 step-down transformer, thus further lowering the grid impedance. Two 1625 tubes operating class AB2 constitute the modulator stage. They are capable of approximately 120 watts output but are normally operated at an 80 to 90 watt level. Series resistors in the grid circuit prevent the grids from swinging too far positive and thus limit the output below the highest obtainable.

The primary of the modulation transformer has a higher impedance than the 1625 tubes would normally work into. This introduces some high-level speech clipping, which in turn increases the average modulation percentage. To eliminate any splatter, as a result of speech clipping, the modulation transformer has been "built out" as a low pass filter. This also attenuates the high frequencies above the speech range. When the transmitter is operated on CW, the CW-phone switch removes the screen voltage from the modulator tubes and shorts the secondary of the modulation transformer.

POWER SUPPLIES

The low voltage power transformer contains all of the filament windings, including the filament for the high voltage rectifiers. It also has a tapped secondary to supply the bias rectifier. A 12 volt center tap winding supplies all of the audio and RF stage filaments. The center tap is grounded and the 6 volt tubes operated from one or the other side to ground, so as to place a balanced load on both halves of the winding.

The 12 volt tubes are operated across both halves of the winding. The low voltage supply with a 5V4G rectifier and condenser input filter, delivers 360 volts at 150 mils to the low power audio and RF stages. The taps on the secondary deliver 75 volts to the 6AL5 bias rectifier, also with a condenser input filter. A resistance network on the bias supply applies the correct bias to the final amplifier, modulator and driver stages.

HIGH VOLTAGE POWER SUPPLY

The high voltage supply consists of the plate transformer, parallel 5R4GY rectifiers, choke input filter and two 125 μ fd electrolytic capacitors in series. A center tapped bleeder balances the series capacitors and also furnishes the modulator screen voltage.

Ordinarily well designed power supplies, using conventional values of paper or oil capacitors, have been found to make violent voltage excursions as loads are suddenly applied or removed. This is known as the dynamic regulation characteristic. To eliminate these voltage excursions, larger capacitors than are practical in the paper or oil type are necessary. This makes the use of electrolytic types mandatory. The DX-100 uses two 125 μ fd 450 volt electrolytic capacitors in series, resulting in a filter capacity of 62.5 μ fd at 900 volts. This is sufficient capacity to assure good dynamic regulation under keying conditions and a fair safety factor on voltage breakdown. Both sides of the AC line are fused in a special line plug and all circuits entering or leaving the transmitter chassis have LC harmonic filters.

NOTES ON ASSEMBLY AND WIRING

In the design of the Heathkit DX-100, no effort was spared to obtain the highest quality components and assemble them in the best possible arrangement. As this transmitter represents a substantial investment, the kit builder should exercise a great deal of care during assembly and wiring. Only by putting the best possible workmanship into the kit, can the best results be obtained from it. There is also a great deal of personal satisfaction in a neat, professional looking transmitter, resulting from careful assembly and wiring. A common factor of radio frequency instruments is the critical placement of leads and components. The use of extensive shielding in the DX-100 has eliminated a great deal of this. However, the lead dress shown in the pictorials should be followed carefully.

Due to the complexity of the DX-100, the construction has been sub-divided into several stages. This unit method of construction reduces one large difficult project to several small easy ones. It also postpones the bulkiness and weight to be encountered in a large transmitter until it is nearly completed. This manual is supplied to assist you in every way to complete the DX-100 with the least possible chance for error. We suggest that you take a few minutes now and read the entire manual through before any work is started. This will enable you to proceed with the work much faster when construction is begun. The large fold-in pictorials are handy to attach to the wall above your work space. Their use will greatly simplify the construction of the kit. These diagrams are repeated in smaller form within the manual. We suggest that you retain the manual in your files for future reference, both in the use of the DX-100 and for its maintenance. During the initial testing of the transmitter, it will not be in its cabinet. **REMEMBER VOLTAGES DANGEROUS TO LIFE ARE PRESENT AT PRACTICALLY ALL POINTS ON THE CHASSIS.**

UNPACK THE KIT CAREFULLY AND CHECK EACH PART AGAINST THE PARTS LIST. In so doing, you will become acquainted with each part. Refer to the charts and other information shown on the inside covers of the manual and on Page 63 to help you identify any parts about which there may be a question. If some shortage is found in checking the parts, please notify us promptly and return the inspection slip with your letter to us. Hardware items are counted by weight and if a few are missing, please obtain them locally if at all possible.

Read the note on soldering on the inside of the back cover. Crimp all leads tightly to the terminal before soldering. Be sure both the lead and terminal are free of wax, corrosion or other foreign substances. Use only the best rosin core solder, preferably a type containing the new activated fluxes such as Kester "Resin-Five," Ersin "Multicore" or similar types.

The actual tube markings may differ from the type specified in the parts list by an additional suffix (A, B, GT, etc.). This denotes a minor variation which will not affect the operation of the completed instrument.

NOTE: ALL GUARANTEES ARE VOIDED AND WE WILL NOT REPAIR OR SERVICE INSTRUMENTS IN WHICH ACID CORE SOLDER OR PASTE FLUXES HAVE BEEN USED. WHEN IN DOUBT ABOUT SOLDER, IT IS RECOMMENDED THAT A NEW ROLL PLAINLY MARKED "ROSIN CORE RADIO SOLDER" BE PURCHASED.

Resistors and condensers generally have a tolerance rating of $\pm 10\%$ unless otherwise stated in the parts list. Therefore, a 100 K Ω resistor may test anywhere from 90 K Ω to 110 K Ω . The letter K is commonly used to designate a multiplier of 1000. The parts furnished with your Heathkit will not adversely affect the operation of the finished DX-100.

In order to expedite delivery to you, we are occasionally forced to make minor substitutions of parts. Such substitutions are carefully checked before they are approved and the parts supplied will work satisfactorily. By checking the parts list for resistors for example, you may find that a 2 K Ω resistor has been supplied in place of a 2.2 K Ω as shown in the parts list. These changes are self-evident and are mentioned here only to prevent confusion in checking the contents of your kit. We strongly urge that you follow the wiring and parts layout shown in the manual. The position of wires and parts is extremely critical in a stable, calibrated transmitter and changes may seriously affect the characteristics of the circuit.

STEP-BY-STEP ASSEMBLY INSTRUCTIONS

The following instructions are presented in a simple, logical, step-by-step sequence to enable you to complete your kit with the least possible confusion.

Be sure to read each step all the way through before starting. When a step is completed, check it off in the space provided. This makes it easy to resume construction after your work has been interrupted.

NOTE: We suggest that you do the following before any work is started.

1. Select from the large fold-in pictorials included with the manual, the diagram showing the phase of construction you are engaged in at the time. Attach this diagram to the wall above your work space.
2. After identifying the parts from the parts list, place them in a large shallow box so that they are readily accessible. This will save considerable time in construction.
3. Thoroughly read the assembly and wiring instructions on the inside rear cover of the manual and refer to the general information on both inside covers of the manual to identify the parts.
4. In assembling the kit, use lockwashers under all nuts unless a solder lug is used or otherwise specified. Use 1/4" x 6-32 screws unless otherwise indicated.

NOTE: Sometimes the builder may find a place where it is difficult to hold a nut for assembly. Using long nosed pliers, press a piece of solder across one side of the nut until the solder is forced part way into the threads. This will hold the nut and furnish a narrow handle useful to insert the nut into tight places.

NOTE: During the assembly and wiring procedure a rag or some soft material should be placed over the workbench to prevent marring or scratching the chassis or component finish. Capacitors, resistors and transformers usually have leads longer than necessary to make the indicated connections. Both in the interest of efficiency and appearance, the leads should be cut to an appropriate length before the connections are made.

ASSEMBLY AND WIRING

(S) means solder.

(NS) means do not solder yet.

NOTE: In designating color codes on mica capacitors, only the significant colors will be given. Silver mica capacitors have red cases and ordinary mica capacitors have brown cases. Illustrations of the components used in this kit are given on Page 63.

VFO

Use the hardware in package #1 for following assembly.

- () Mount the differential tuning capacitor to the VFO sub-chassis as shown in Figure 2. Place a 3/8 lockwasher on the back of the chassis and a 3/8 flat washer and nut on the front. See Figure 3. Align the capacitor so the stator plates appear as shown in Figure 2 before tightening.

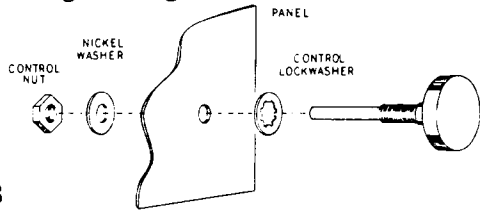

Figure 3

- () Screw the two iron core slugs through the bushings on the top of the VFO sub-chassis from the bottom side. The iron core slugs should be inside the chassis with the threaded shafts protruding through the top.
- () Screw the two special tension nuts over the shaft. See parts illustrations on Page 63 to identify these nuts. Tighten just enough to allow the shaft to turn with light torque.
- () Mount the 160 M coil 40-54 over one iron core slug on the left side of the chassis as viewed from the bottom rear. Assemble in following order: 1/4" 6-32 screws through chassis from the top, coil form brackets, lockwashers, 6-32 nuts.

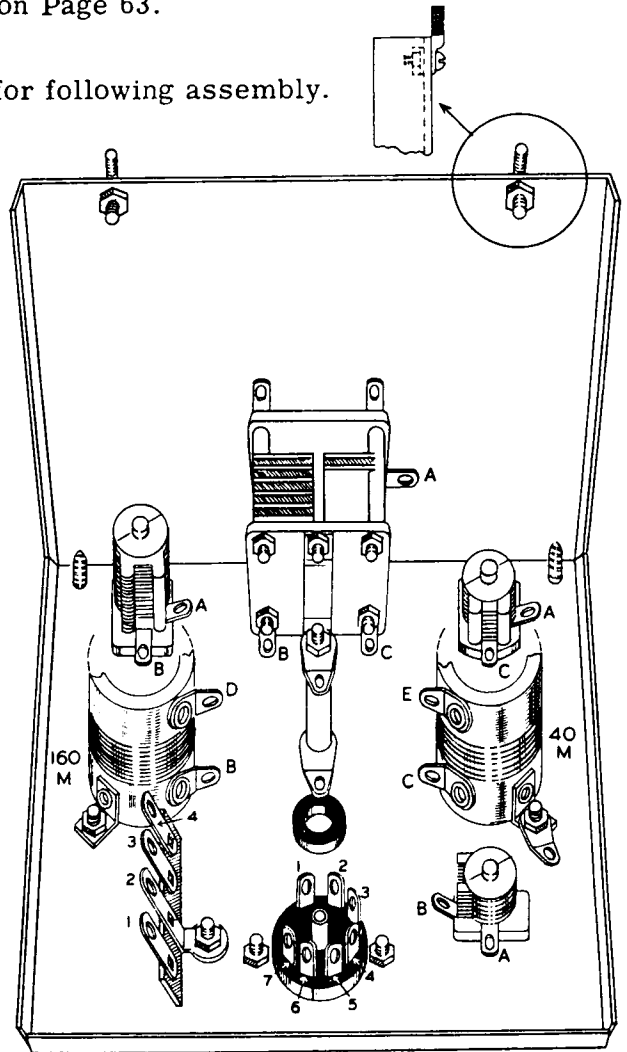

Figure 2

- () Mount the 40 M coil 40-55 on the other side of the chassis in the same manner but using a solder lug on the rear bracket in place of the lockwasher. See Figure 2.
- () Mount the 20 $\mu\mu\text{f}$ trimmer capacitor in front of the 160 M coil. Position as shown in Figure 2 and secure using the 1/4" nut on top of the chassis.
- () Mount a 9 $\mu\mu\text{f}$ trimmer capacitor in front of the 40 M coil in the same manner. Position as shown in Figure 2.
- () Mount a 9 $\mu\mu\text{f}$ trimmer capacitor to the rear of the 40 M coil and position as shown in Figure 2.
- () Referring to Figure 5, insert a 1 1/2" 6-32 screw through a solder lug, then through the dial light bracket and chassis top. Position the dial light and solder lug as shown. On the underside of the chassis, slip a solder lug, a 1 1/8" spacer, another solder lug and a 6-32 nut over the protruding screw. Position the solder lugs as shown in Figure 2 and tighten.
- () Insert a 5/16" rubber grommet in the hole to the rear of this assembly.
- () Mount the 7-pin shielded ceramic tube socket with the pins positioned as shown in Figure 2 using 3-48 screws and nuts.
- () Mount a 4-lug terminal strip as shown in Figure 2 using a lockwasher under the nut.

See Pictorial 1 for the following wiring. The bare wire used in this section is the smaller size.

- () Connect a tinned bare wire from point A on the 20 $\mu\mu\text{f}$ trimmer capacitor (S) to point A on the differential tuning capacitor (NS).
- () Connect a bare wire from point A on the differential tuning capacitor (S) to point A on the front 9 $\mu\mu\text{f}$ trimmer capacitor (NS).

- () Connect a bare wire from this point (S) through the solder lug on 40 M coil bracket (NS) to point A on the rear 9 $\mu\mu\text{f}$ trimmer capacitor (NS).
- () Connect a bare wire from the solder lug on the 40 M coil bracket (S) through the solder lug at the base of the 1 1/8" spacer (NS) to the #2 terminal (see Figure 2) of the 4-lug terminal strip (NS).

- () Connect a bare wire from the top solder lug on the 1 1/8" spacer (NS) through the bottom solder lug (S), over to the tube socket through pin 3 on the tube socket (NS) to the center post of the tube socket (NS).

- () Run a bare wire through terminal B of the 160 M coil (NS) then through terminal B of the differential capacitor to point B of the 20 $\mu\mu\text{f}$ trimmer capacitor. Solder the connections on the two capacitors and make a mechanical connection at the coil terminal (NS).

- () Run a bare wire through terminal C on the 40 M coil (NS) through terminal C on the differential capacitor to point C on the 9 $\mu\mu\text{f}$ trimmer capacitor. Solder the connections on the two capacitors and allow 3" of bare wire to protrude from the rear of the coil terminal for later connection to the switch. See Pictorial 1.

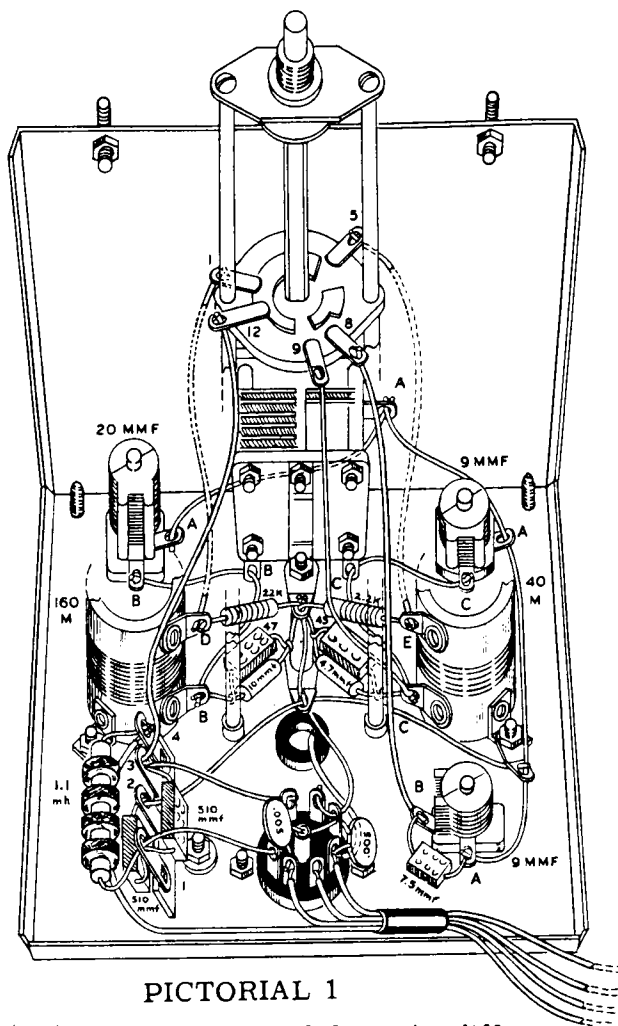

PICTORIAL 1

- () Run a bare wire through terminal C on the 40 M coil (NS) through terminal C on the differential capacitor to point C on the 9 $\mu\mu\text{f}$ trimmer capacitor. Solder the connections on the two capacitors and allow 3" of bare wire to protrude from the rear of the coil terminal for later connection to the switch. See Pictorial 1.

NOTE: In the next six steps, the components should be mounted with very short leads. First, however, examine Pictorial 1 and note that the components must be so placed as to clear the switch which will be mounted later.

- () Wrap the leads of a 47 $\mu\mu\text{f}$ silver mica capacitor (yellow-purple-black) around the leads of a 10 $\mu\mu\text{f}$ N750 ceramic capacitor as shown in Figure 4. Solder quickly with a hot iron to prevent damage to the capacitor.



Figure 4

- () Connect the 10 $\mu\mu\text{f}$ N750 ceramic capacitor from terminal B on the 160 M coil (S) to the top solder lug on the 1 1/8" spacer (NS).

- () Wrap the leads of a 43 $\mu\mu\text{f}$ silver mica capacitor (yellow-orange-black) around the leads of a 4.7 $\mu\mu\text{f}$ N750 ceramic capacitor and solder as in the previous step.

- () Connect the 4.7 $\mu\mu\text{f}$ N750 ceramic capacitor from terminal C on the 40 M coil (S) to the top solder lug on the 1 1/8" spacer (NS).

- () Connect a 22 K Ω 1/2 watt resistor (red-red-orange) from the top solder lug on the spacer (NS) to terminal D of the 160 M coil (NS).

- () Connect a 2.2 K Ω 1/2 watt resistor (red-red-red) from the top solder lug on the 1 1/8" spacer (S) to terminal E of the 40 M coil (NS).

- () Mount the VFO switch with the long studs through the 1/8" holes in the top of the chassis, using the hardware supplied with the switch. Note the position of the switch contacts in Pictorial 1 when mounting.
- () Connect a short bare wire from switch terminal 1 (S) to the 160 M coil terminal D (S).
- () Connect a short bare wire from switch terminal 5 (S) to the 40 M coil terminal E (S).
- () Connect the 3" bare wire coming from the 40 M coil terminal C to switch terminal 9 (S).
- () Connect a bare wire from switch terminal 8 (S) to terminal B on the rear 9 $\mu\mu\text{f}$ trimmer capacitor (NS).
- () Connect a 7.5 $\mu\mu\text{f}$ silver mica capacitor (violet-green-gold) from terminal B (S) to terminal A (S) on the 9 $\mu\mu\text{f}$ trimmer capacitor.
- () Connect a 510 $\mu\mu\text{f}$ silver mica capacitor (green-brown-brown) from lug 2 on the 4-lug terminal strip (S) to lug 1 on the terminal strip (NS).
- () Connect a 510 $\mu\mu\text{f}$ silver mica capacitor from lug 1 on the terminal strip (NS) to lug 3 (NS).
- () Connect a bare wire from terminal 12 on the switch (S) to lug 3 on the terminal strip (NS).
- () Connect a bare wire from lug 3 on the terminal strip (S) to pin 1 on the tube socket (S).
- () Connect a bare wire from lug 1 on the terminal strip (NS) to pin 7 on the tube socket (S).
- () Connect a 4 pi, 1.1 mh RF choke from lug 1 on the terminal strip (S) to lug 4 (NS).
- () Connect a blue wire, 11" long, to lug 4 (S). Leave the other end free.
- () Cut both leads of a .005 μfd disc ceramic capacitor to 1/2" length. Connect one lead to the center post of the tube socket (S).
- () Connect the other lead to pin 6 on the tube socket (NS).
- () Connect one end of an orange wire, 8" long, to pin 6 (S). Leave the other end free.
- () Connect one end of a red wire, 7" long, to pin 5 (S). Leave the other end free.
- () Connect a black wire to pin 4 (NS). Run the wire through the 5/16" rubber grommet to terminal 1 of the pilot light (NS).
- () Connect a short bare wire from terminal 2 of the pilot light (S) to the adjacent solder lug (S).
- () Cut one lead of a .005 μfd disc ceramic capacitor to 5/8" length and the other lead to 3/8" length.
- () Run the 5/8" lead through pin 3 of the tube socket to pin 2. Solder both connections.
- () Connect the 3/8" lead to pin 4 (NS).
- () Connect the end of a black wire 8" long to pin 4 (S). Leave the other end free.
- () Gather the four loose wires together at a point just behind the tube socket and secure with scotch tape or twine as shown in Pictorial 1.
- () Assemble the tuning dial as shown in Figure 6, using 3-48 screws, lockwashers and nuts with 1/16" fiber spacing washers.
- () Insert a 1/4 x 8-32 set screw in the dial hub. Then mount the dial assembly to the tuning capacitor shaft. Slide the dial assembly on far enough so the capacitor shaft is flush with the front of the dial hub.

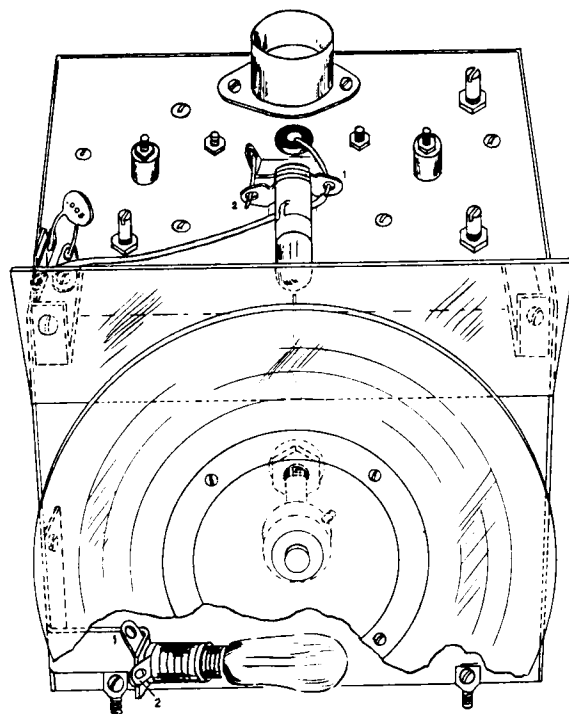

Figure 5

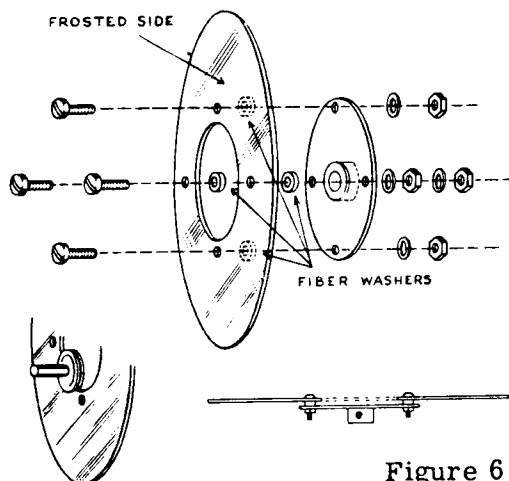

Figure 6

- () Turn the tuning capacitor until the rotor is fully meshed with the larger stator section, then rotate the dial until the index mark to the left of the 7000 kc calibration is straight up and tighten the set screw.
- () Mount the green plastic light shield to the small aluminum L brackets with 1/4" 6-32 screws, lockwashers and nuts. If there are burrs in the light shield slot, clean them out with a fine wire.
- () Mount the light shield to the top of the VFO chassis, using #6 sheet metal screws as shown in Figure 5. Include a single-lug terminal strip and solder lug on the right side as shown.
- () Connect a black wire from terminal 1 of the pilot lamp socket (S) to the insulated lug of the 1-lug terminal strip (NS).
- () Connect a .005 μ fd disc ceramic capacitor from the same terminal (NS) to the adjacent solder lug (S).
- () Mount two 6-32 spade screws to the bottom flange of the chassis as shown in Figure 2, using lockwashers under the nuts.

Temporarily set this unit aside.

ASSEMBLY AND WIRING OF CHASSIS BASE

- () Insert 3/4" rubber grommets in holes A, B, C and D. See Pictorial 2.
- () Insert a 3/8" rubber grommet in hole E.
- () Mount a 3-lug terminal strip AA in the hole adjacent to this grommet, using a 1/4" 6-32 screw and lockwasher under the nut. Position as shown in Pictorial 2 on Page 12.
- () Mount a 4-lug terminal strip BB on the side of the chassis to the left of the 3-lug terminal strip, using the same hardware. Position as shown.
- () Mount a 5-lug terminal strip CC in the next hole along the side of the chassis. Position as shown.
- () Mount a 4-lug terminal strip DD in the next hole forward. Position as shown.
- () Mount a 3-lug terminal strip EE in the next hole forward. Position as shown.
- () Mount the 5-lug "Jones" terminal strip FF using the two holes in the chassis side as shown.
- () Mount a 3-lug terminal strip GG ahead of the 5-lug "Jones" terminal strip.
- () Mount the coaxial jack on the outside rear of the chassis, using the short 1/4 x 4-40 screws and the large 4-40 nuts. Include a solder lug under the nut shown.
- () Mount a 10-32 x 5/8 screw through the hole adjacent to the jack. Include a #10 solder lug inside the chassis and a #10 lockwasher and nut outside the chassis.
- () Using 6-32 hardware, mount a ceramic octal saddle-type socket in the rear of the chassis with the keyway toward the center. See Pictorial 2.
- () Mount the 6-lug "Jones" terminal strip HH on the side of the chassis next to the socket. In mounting, place solder lugs between the chassis and the terminal strip feet and lockwashers under the nuts. Position the solder lugs as shown in Pictorial 2.
- () Loosely mount the DPST toggle switch in hole M, first screwing the hex nut all the way back on the shaft. The slot in the shaft must be toward the bottom of the chassis. Use the knurled nut on the front to hold the switch. Mount the SPST toggle switch in hole H in the same manner.
- () Loosely mount the 3-pole 2-position rotary CW-phone switch in hole N, using a 3/8 lockwasher behind the chassis and a flat washer and control nut in front. Position as shown in Pictorial 2.
- () Mount a .5 megohm potentiometer in hole G in the same manner. (Long shaft without slot.)
- () Mount a closed circuit phone jack in hole O, omitting the lockwasher.

NOTE: The nuts and flat washers on the controls must be removed to mount the panel; so tighten just sufficiently to hold them in place for wiring in the position shown in Pictorial 2.

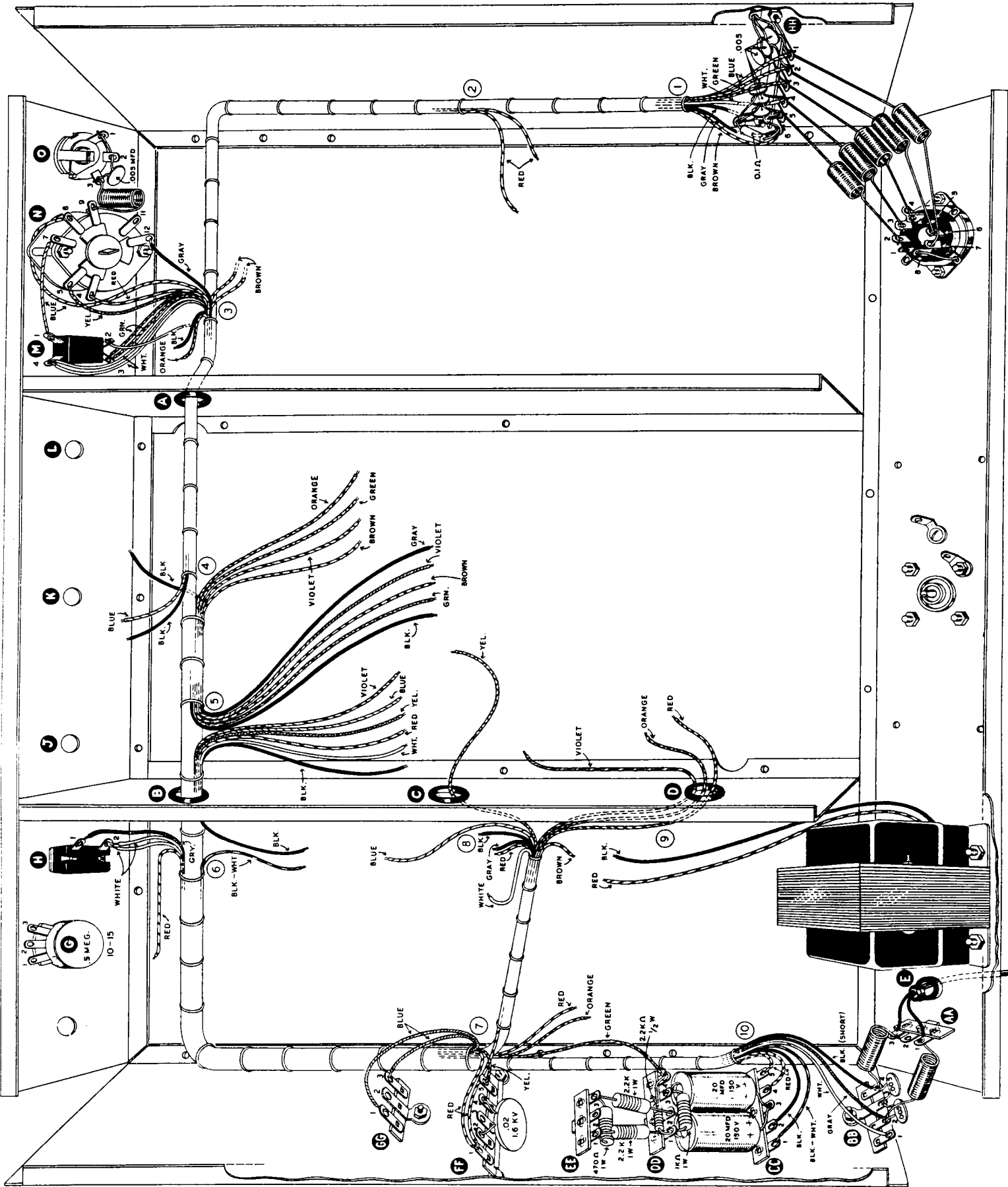

PICTORIAL 2

- () Mount the 150 ma filter choke next to the 3/8 grommet in the rear apron of the chassis using 8-32 screws, lockwashers and nuts. The choke leads must be toward the center chassis brace. Center the choke before tightening the screws.
- () Cut the leads of a .005 μ fd disc ceramic capacitor to 1/2" and connect between lug 3 of BB (NS) and lug 4 of BB (NS).
- () Cut the leads of a .005 μ fd disc ceramic capacitor to 1/2" and connect between lug 2 of BB (NS) and lug 3 of BB (NS).
- () Connect a line filter choke (20 turns of #17 wire) between lug 1 of terminal strip AA (NS) and lug 2 of BB (NS).
- () Connect a line filter choke between lug 3 of AA (NS) and lug 4 of BB (NS).
- () Connect the positive side of a 20 μ fd 150 volt electrolytic capacitor (side marked +) to lug 3 of terminal strip CC (NS).
- () Connect the negative side to lug 1 of DD (NS).
- () Connect the positive side of a 20 μ fd 150 volt capacitor to lug 3 of CC (NS).
- () Connect the negative side to lug 3 of DD (NS).
- () Connect a 1 K Ω 1 watt resistor (brown-black-red) from lug 1 of DD (NS) to lug 3 of DD (NS).
- () Connect a 470 Ω 1 watt resistor (yellow-violet-brown) from lug 1 of EE (NS) to lug 3 of EE (NS).
- () Connect a 2.2 K Ω 1 watt resistor (red-red-red) from lug 1 of DD (NS) to lug 1 of EE (NS).
- () Connect a 2.2 K Ω 1/2 watt resistor (red-red-red) from lug 1 of DD (S) to lug 4 of DD (NS).
- () Connect a 2.2 K Ω 1 watt resistor (red-red-red) from lug 3 of EE (NS) to lug 2 of DD (S).
- () Connect a .02 μ fd 1.6 kv disc ceramic capacitor from lug 2 of FF (NS) to lug 4 of FF (NS). Keep the leads on the condensers short and make sure that they do not touch the ground or other terminals.
- () Connect a .005 μ fd disc ceramic condenser from the ground solder lug adjacent to lug 1 of terminal strip HH (NS) to lug 1 of HH (NS).
- () Connect a .005 μ fd disc ceramic capacitor from the same solder lug (NS) to lug 2 of HH (NS).
- () Connect a .005 μ fd disc ceramic capacitor from the same solder lug (S) to lug 3 of HH (NS).
- () Connect a .005 μ fd disc ceramic capacitor from the ground solder lug adjacent to lug 6 of terminal strip HH (NS) to lug 6 of HH (NS).
- () Connect a .005 μ fd disc ceramic capacitor from the same ground solder lug to lug 5 of HH (NS).
- () Connect a .005 μ fd disc ceramic capacitor from the same ground solder lug to lug 4 of HH (NS).
- () Connect a 0.1 Ω shunt resistor from the same solder lug (S) to lug 6 of HH (NS). Make sure none of the capacitors are shorted to ground or to the other terminals.
- () Connect a line filter choke from lug 5 of HH (NS) to pin 2 of the ceramic socket (S).
- () Connect a line filter choke from lug 4 of HH (NS) to pin 3 of the socket (S).
- () Connect a line filter choke from lug 3 of HH (NS) to pin 4 of the socket (S).
- () Connect a line filter choke from lug 2 of HH (NS) to pin 6 of the socket (S).
- () Connect a line filter choke from lug 1 of HH (NS) to pin 7 of the socket (S).
- () Connect a bare wire from pin 8 of the socket (S) to the adjacent ground lug (S).
- () Cut one lead of the .005 μ fd disc ceramic capacitor to 1/2" and the other lead to 1". Connect the 1/2" lead to terminal 3 of the phone jack O (NS).
- () Run the other lead through terminal 2 to terminal 1. Solder both terminal 2 and terminal 1 of the phone jack.
- () Connect a line filter choke from terminal 3 of the phone jack (S) to terminal 9 of the CW-phone switch N (S).

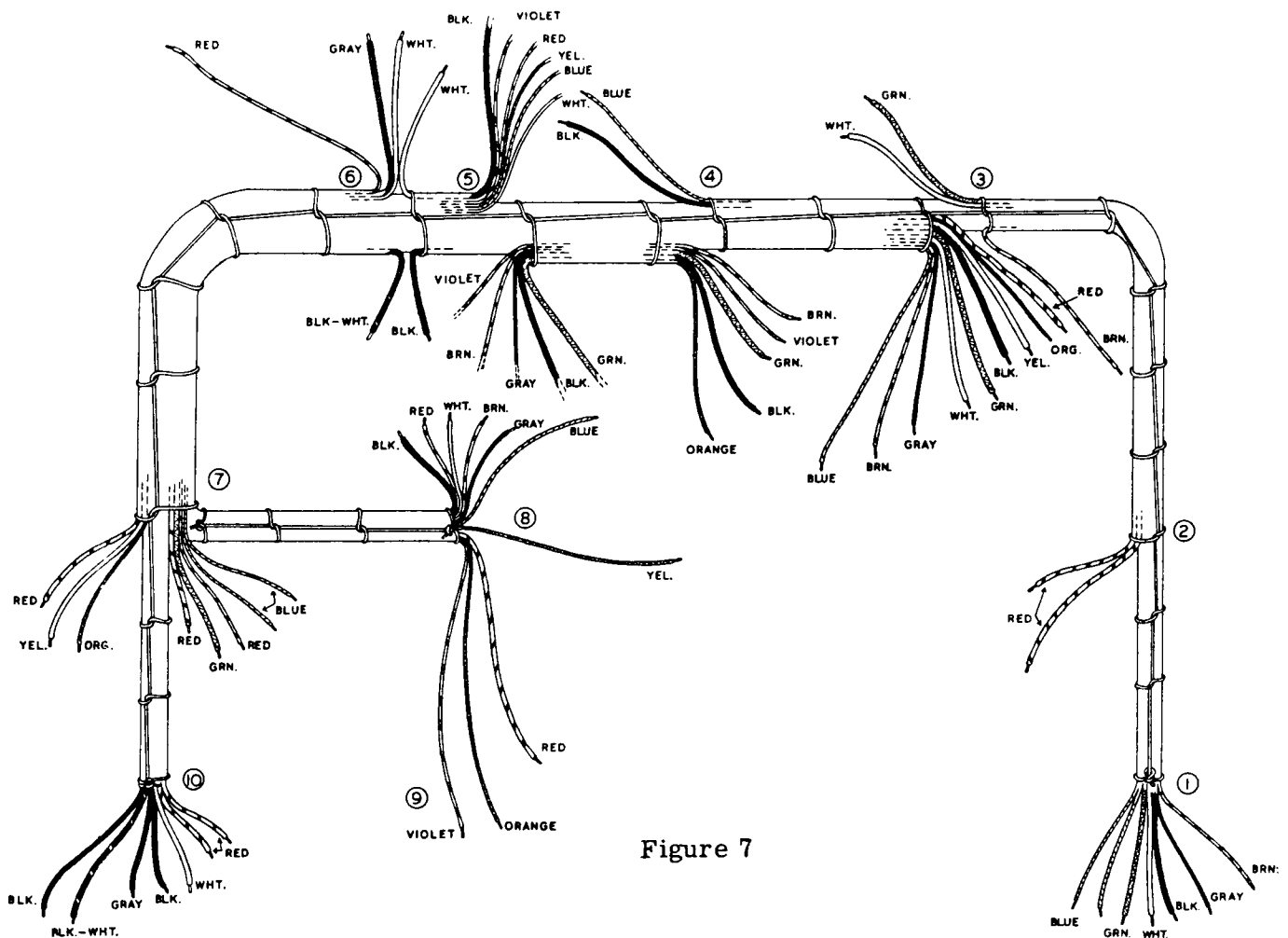

Figure 7

NOTE: The cable must be run through grommets A and B in the chassis frame. Some care must be exercised to prevent damage to the cable. In general, the leads should be made to lie flat along the cable in the direction they normally are going. Lay the chassis flat so that it appears as in Pictorial 2. Select the end of the cable that has seven leads; black, two blue, gray, white, green and brown. See Figure 7. Start this end through grommet B from the left side, then through grommet A. As the various breakout points approach the grommets, guide the loose wires against the cable and through the grommet. Continue this process until harness points 1, 2 and 3 are in the right hand compartment, points 4 and 5 in the center compartment and 6, 7, 8, 9 and 10 are in the left hand compartment. In the left and right hand compartment, guide the cable along the flange and against the sides of the chassis as shown. In wiring the cable, turn the chassis in the position most convenient for the section being wired.

- () At point 1 of the cable, connect either blue lead to lug 1 of HH (S).
- () Connect the other blue lead to lug 2 of HH (S).
- () Connect the green lead to lug 3 of HH (NS).
- () Connect the white lead to lug 4 of HH (S).
- () Connect the black lead to lug 5 of HH (NS).

- () Connect the gray and brown leads to lug 6 of HH (NS). Make sure none of the capacitors line filter chokes or terminals are shorted to each other or to ground.
- () At point 3 of the harness, connect the two green wires to terminal 3 of the toggle switch M (S).
- () Connect a bare wire 3 1/2" long to terminal 2 of the switch (S). Leave the other end free.

- () Connect the two white wires to terminal 4 of the toggle switch M (S).
- () Connect the blue wire to terminal 8 of the CW-PHONE switch N (S). Run the wire as shown in Pictorial 2.
- () Cut a piece of blue wire 3 1/2" long. Connect one end to terminal 7 of switch N (S) and the other end to terminal 1 of switch M (NS).

- () Connect the red wire to terminal 4 of switch N (S).
- () Connect the yellow wire to terminal 5 of switch N (NS).
- () Connect the gray wire to terminal 12 of switch N (S).
- () At point 6 on the cable, connect the gray wire to terminal 1 of the toggle switch H (S).
- () Connect the two white wires to terminal 2 of H (S).

- () At point 7 on the cable, connect the yellow wire to lug 5 of the strip FF (NS).
- () Connect the two short heavily insulated red wires to lug 1 of FF (NS). At this point, there is a smaller diameter longer red wire which will be connected later.
- () Connect the green wire to lug 4 of strip DD (S).
- () Connect either blue wire to lug 1 of strip GG (NS).
- () Connect the other blue wire to lug 3 (NS).

NOTE: These wires on the terminal strip GG connect to the octal socket on the rear of the chassis. No further connection will be made to them now as they are used only when it is desired to obtain audio output from the transmitter. This operation will be explained later on.

- () At point 10 on the harness, connect either red wire to lug 5 of the strip CC (NS).
- () Connect the other red wire to lug 4 (NS).
- () There is one long black wire and one short black wire at this point in the cable. Connect the short black wire to lug 4 of strip BB (NS). Connect the long black wire to lug 2 of CC (NS). Connect the white and black wire to lug 1 of strip CC (NS).

- () Connect the gray wire to lug 2 of BB (S).
- () Connect the white wire to lug 1 of BB (NS).
- () Run the yellow wire at point 8 on the cable through grommet C and the red, orange and violet wire at point 9 on the cable through grommet D.

Set the chassis aside for the time being.

CHASSIS TOP PLATE ASSEMBLY AND WIRING

NOTE: The holes in this section are too numerous to be designated by a numbering or letter system and some of the holes are merely for ventilation. Consequently the assembly must be performed by paying strict attention to Figure 8 and Pictorials 3 and 4. The larger components will be mounted first and the rest of the parts located by their relationship to them.

In mounting the ceramic wafer sockets, the following assembly procedure applies: Insert a 1/2" 6-32 binder head screw through the chassis from the top side. On the underside of the chassis, place a #6 fiber washer, the socket, another fiber washer and a nut. This system protects the ceramic socket from direct contact with the metal chassis. However, care must still be taken to prevent damage to the ceramic socket.

Turn the chassis top plate until the two largest holes are toward the rear and to the right of center. Now the two dimpled holes should be to the front right with the dimpling protruding upward. In mounting miniature sockets, note the pin positions by noting the placement of the blank pin space. Octal sockets are positioned by the keyway direction and the large 7-prong socket by the placement of the two larger pins. Refer to Figure 8 on Page 16 for the following assembly.

Use the hardware in package #2 for the following assembly:

- () In the front right-hand corner, mount a 9-pin miniature socket with the pins positioned as shown in Figure 8. Use 3-48 screws and nuts with the screwheads on top of the chassis. No lockwashers are used in the mounting of miniature sockets. This is the 12AX7 speech amplifier stage.
- () To the left of a 12AX7 socket, mount another 9-pin socket in position as shown. This is the 12BY7 audio driver stage.

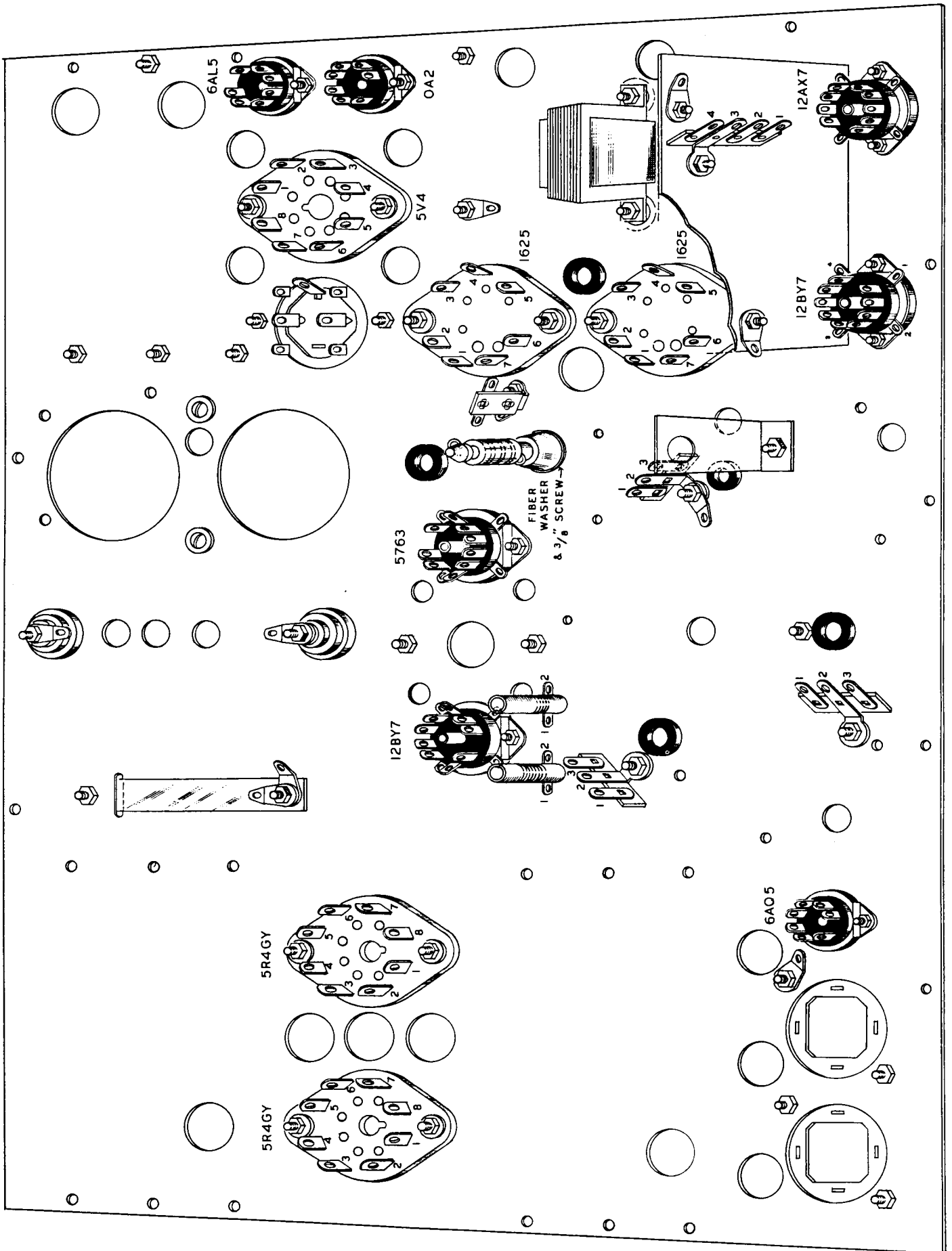
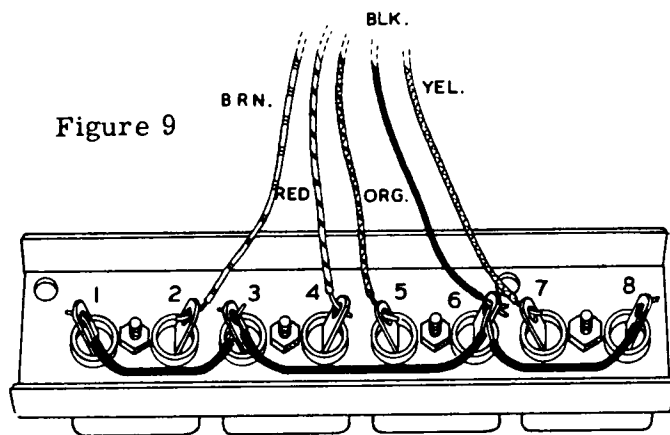

Figure 8

- () Directly to the rear of the 12BY7 stage are two 1 3/8" holes with two 5/32" holes close to each side of them. Mount large 7-pin ceramic wafer sockets in these holes, using the procedure given in the note at the beginning of the section. The two larger holes in the socket are the filament connections of the 1625 modulator tubes and are placed toward the chassis center. Center the sockets in the holes before tightening the screws.
- () To the rear of the modulator sockets is another large hole with its accompanying small holes. Mount the metal capacitor mounting wafer here, using 1/4" 6-32 screws, lockwashers and nuts. The wafer is mounted on the top side of the chassis plate with the lockwashers and nuts on the underside of the chassis plate.
- () To the right of the capacitor mounting wafer, mount an octal ceramic socket with the keyway toward the chassis rear. Use the hardware, washers and method described for the modulator sockets. Center the socket in the hole before tightening. This is the 5V4 low voltage rectifier.
- () To the right of the octal socket and near the chassis edge, are two 5/8" holes with 1/8" holes close to them. Observe the pin locations as shown in Figure 8 and mount two 7-pin miniature sockets here, using 3-48 screws and nuts. The front socket is for the OA2 regulator tube and the rear socket for the 6AL5 bias rectifier.
- () At the chassis center are three 3/4" holes in a row. The two outside holes take 9-pin miniature sockets and the center hole is for the driver coil. Mount a 9-pin miniature socket in the left-hand hole using 3-48 hardware and position the pins as shown. This socket is for the 12BY7 crystal oscillator-buffer stage.
- () A 9-pin miniature socket for the 5763 driver stage is mounted in the right-hand hole with the pins positioned as shown.
- () In the left front corner are two 1 3/8" holes with their accompanying 5/32" holes at a 45° angle in relation to the chassis front. Mount the two phenolic capacitor mounting wafers at this point. The wafers are mounted on top of the chassis plate using 3/8" 6-32 screws, through the wafer and chassis and lockwashers and nuts on the bottom side of the chassis. Substitute a solder lug for the lockwasher under the mounting screw closest to the chassis center and position as shown in Figure 8. These wafers hold the two 125 μfd high voltage filter capacitors.
- () To the right of the insulated wafers is a 5/8" hole for the 6AQ5 clamp tube. Mount a 7-pin miniature socket here with the pins positioned as shown in Figure 8, using 3-48 hardware.
- () On the left side of the chassis near center are two 1 3/8" holes for the 5R4GY high voltage rectifiers. Using the procedure for mounting ceramic wafer sockets, mount two octal sockets with the keyways toward the chassis front. Center the sockets with the holes before tightening.
- () Mount the small audio driver transformer on the two dimples to the right of the 1625 sockets. Use 8-32 screws, lockwashers and nuts and position the transformer so the side having the two green leads and one black lead is toward the rear.
- () Insert a 3/8" rubber grommet in the hole between the 1625 sockets and the driver transformer.
- () Mount the audio section shield plate as shown in Figure 8 at the two small holes directly behind the 12AX7 and 12BY7 sockets, using 1/4" 6-32 hardware.
- () Mount two solder lugs in the audio shield plate in the holes shown and position as shown in Figure 8 using 1/4" 6-32 screws and nuts without a lockwasher.
- () Mount a 4-lug terminal strip on the audio shield plate at the remaining hole, using the same hardware but with a lockwasher.
- () Install three 3/8" and one 5/16" rubber grommets in the chassis holes as shown in Figure 8.
- () Using 6-32 hardware, mount the 3/4" wide switch bracket in front of the 5/16" grommet and 3/8" hole. Align the bracket parallel with the front edge of the chassis.

- () Assemble four crystal sockets on the socket mounting plate using 1/2" 4-40 screws and small 4-40 nuts as shown in Figure 9.
- () Connect a bare wire to point 1 on the socket terminals (S). Slip a 7/8" length of sleeving over the wire and connect to point 3 (S). Slip a 1 3/4" length of sleeving over the wire and connect to point 6 (NS). Slip a 7/8" length of sleeving over the wire and connect to point 8 (S).

Figure 9



- () Connect a black wire 2 3/8" long to point 6 (S).
- () Connect a brown wire 3 7/8" long to point 2 (S).
- () Connect a red wire 4" long to point 4 (S).
- () Connect an orange wire 4 1/2" long to point 5 (S).
- () Connect a yellow wire 4 3/4" long to point 7 (S). Make sure none of the leads short to the mounting frame and strip the other ends of the wire.
- () Mount the crystal assembly on top of the chassis plate in the position shown in Pictorial 4, using 3/4" 6-32 screws. The leads pass through the hole next to the 5/16" grommet. The screws pass through the hole just to the rear of the grommet and through the hole to the rear of the 3/8" hole near the front of the chassis.
- () On top of the chassis directly behind the 5/16" grommet is a 5/32" hole. Mount a 4-lug terminal strip here and position as shown in Pictorial 4. On the under side of the chassis, using the same screw, mount a 3-lug terminal strip and solder lug. Position as shown in Figure 8.
- () About 2 1/2" to the rear of the 3-lug terminal strip is a group of three small holes. Mount the 2 1/2 mh RF choke on the ceramic insulator in first hole using 6-32 x 3/8 screw. Position terminals of the 2 1/2 mh choke as shown in Pictorial 3, Page 20. Use #6 fiber washer.
- () Using the two small holes behind this choke, mount the 1 1/4" wide variable capacitor bracket on top of the chassis plate. Include a solder lug at the centermost hole as shown in Pictorial 4 and a 1-lug terminal strip and solder lug below the chassis on the other screw as shown in Figure 8. Use 6-32 hardware and position the solder lug and terminal strip as shown in the illustrations.
- () Mount a 5-lug terminal strip on top of the chassis behind the front center 3/8" grommet as shown in Pictorial 4.
- () In front of the 12BY7 oscillator socket are two 5/16" diameter holes for the oscillator coils. The slug tuned coils are plugged into these holes from the bottom side of the chassis with the larger coil on the left, the smaller on the right, and the two terminals marked in red toward the right side of the chassis. See Figure 8.
- () In front of these coils is a 3/8" grommet with a small hole behind it. Mount a 3-lug terminal strip using this hole and position the strip as shown.
- () Near the front center of the chassis are two small holes close together. Using the centermost hole, mount a 3-lug terminal strip and position as shown in Figure 8.

PARTIAL WIRING

NOTE: In all of the following wiring it must be remembered that this section fits on the chassis base. Consequently the wiring cannot exceed certain space limitations. It is advisable to place the chassis base frame on the chassis top in its normal position and mark the top chassis plate with a pencil by tracing around the chassis base frame. This will indicate the wiring clearance necessary. The proper relationship of the parts will occur when the holes around the edge of the chassis top plate match the holes in the edge of the chassis base. A glance at the full bottom pictorial will clarify this.

AUDIO SECTION WIRING

CAUTION: None of the wiring in this section should project past the front of the tube sockets.

- () On the 12AX7 socket pass a 4 1/2" bare wire through ground lug 4, through pin 9 to the center shield post. Solder the ground lug and the center shield post only. See Pictorial 3.
- () Cut both leads of a .005 μ fd disc ceramic capacitor to 1/4" length. Connect one lead to pin 9 (S). Connect the other lead to pin 8 (NS).
- () Cut both leads of a 4700 Ω 1/2 watt resistor (yellow-violet-red) to 1/2" length and connect one lead to pin 8 (NS). Connect the other lead to ground lug 1 (NS).
- () Cut one lead of a 470 K Ω 1/2 watt resistor (yellow-violet-yellow) to 3/8" length and connect to pin 7 (NS).
- () Cut the other lead to 1" and connect to ground lug 2 (S). Run resistors as shown in Pictorial 3.
- () Cut both leads of a 4700 Ω 1/2 watt resistor to a 3/8" length. Connect one lead to ground lug 3 (S). Connect the other lead to pin 3 (NS).
- () Cut two black wires to 5 1/2" length and strip both ends. Connect one wire to pin 4 of the 12AX7 socket (S). Run wire against the chassis and shield plate to pin 4 of the 12BY7 socket (NS).
- () Connect the other wire from pin 5 of the 12AX7 socket (S) to pin 5 of the 12BY7 socket (NS).
- () Connect one lead of a .1 μ fd 400 volt paper capacitor to the lefthand solder lug on the audio shield plate (NS) and the other end to lug 1 of the 4-lug terminal strip (NS). See Pictorial 3. Any "outside foil" or "ground" markings on paper capacitors may be disregarded in wiring this circuit. They may be connected with either "polarity."
- () Connect one lead of a .1 μ fd 400 volt paper capacitor to the left-hand solder lug (S) and the other lead to lug 2 of the strip (NS).
- () Bend the leads of a 100 K Ω 1/2 watt resistor (brown-black-yellow) so it can be connected as shown in Pictorial 3. One lead goes to lug 2 of the terminal strip (NS) and the other lead to lug 4 (NS).
- () Bend the leads of a 47 K Ω 1/2 watt resistor (yellow-violet-orange) in the same manner. One lead goes to lug 1 (NS) and the other lead to lug 4 (NS) on the terminal strip.
- () On one side of the driver transformer are two blue leads. Run either lead around the corner of the audio shield plate close against the chassis and up to lug 4 of the terminal strip. See Pictorial 3. (NS).
- () Connect the negative lead of a 2 μ fd 50 volt electrolytic capacitor to ground lug 1 on the 12AX7 socket (S).
- () Cover the positive lead of the 2 μ fd capacitor with a 5/8" length of sleeving and connect to pin 1 of the 12BY7 socket (NS).
- () Slip two 15/16" lengths of sleeving over the leads of a 510 μ f mica capacitor (green-brown-brown). Connect one lead of the capacitor to pin 1 of the 12AX7 socket (NS) and the other lead to pin 2 of the 12BY7 socket (NS).
- () Cut both leads of a 100 K Ω 1/2 watt resistor to 7/16" length. Connect one lead to pin 1 of the 12AX7 socket (S).
- () Connect the other lead to lug 1 of the terminal strip (S).
- () Cut both leads of a 3" green wire back 5/16". Connect one end to pin 2 of the 12AX7 socket (S). Leave the other end free.
- () Connect the negative lead of a 2 μ fd 50 volt electrolytic capacitor to the solder lug at the top right of the shield plate (NS). See Pictorial 3 for capacitor placement.
- () Slip a 7/8" length of sleeving over the positive lead and connect the lead to pin 8 of the 12AX7 socket (S). Make sure all other connections are clear.
- () Connect the negative lead of a 2 μ fd 50 volt electrolytic capacitor to the same solder lug (S) and the positive lead to pin 3 of the 12AX7 socket (S). Make sure the connections are clear of the other terminals and ground.

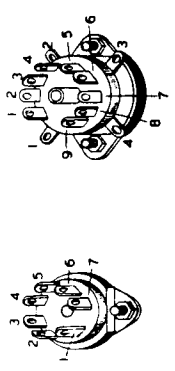

LUG NUMBERS ON SOCKETS - 6A05, 6AL5, AND OA2

LUG NUMBERS ON SOCKETS - 12BY7, 5763, AND 12AX7

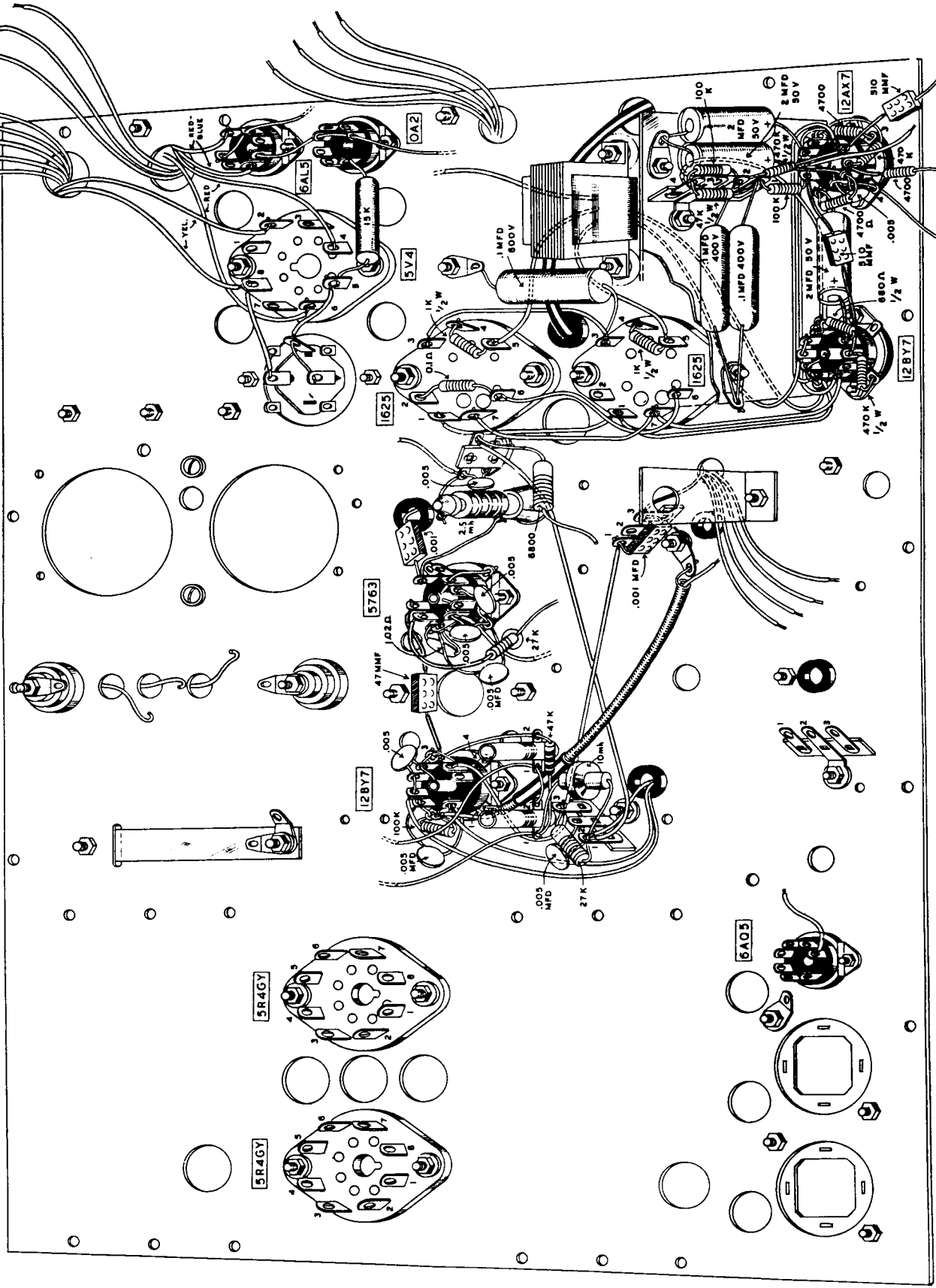

PICTORIAL 3

- () Cut both leads of a 470 K Ω 1/2 watt resistor (yellow-violet-yellow) to 7/8" length. Connect one lead to pin 6 of the 12AX7 socket (NS) and the other lead to lug 2 of the terminal strip (S).
- () Slip a 1" length of sleeving over one lead of a 510 $\mu\mu\text{f}$ mica capacitor (green-brown-brown) and connect this lead to pin 6 of the 12AX7 socket (S). Leave the other end free.
- () Slip a 5/8" length of sleeving over one lead of a 4700 Ω 1/2 watt resistor (yellow-violet-red). Connect this lead to pin 7 of the 12AX7 socket (S). Leave the other end free.
- () Cut one lead of a 680 Ω 1/2 watt resistor (blue-gray-brown) to 13/16" length. Bend a Z in the lead close to the resistor as shown in Pictorial 3. Run this lead through pin 9 of the 12BY7 socket to the adjacent ground lug. Solder both connections.
- () Cut the other resistor lead to 1/2" length and connect to pin 1 (S).
- () Cut one lead of a 470 K Ω 1/2 watt resistor (yellow-violet-yellow) to 1/4" length and connect to pin 2 (S).
- () Bend the other lead back to ground lug 2 (S). As pin 3 is not used, bend the terminal slightly toward the socket center to clear the resistor.
- () Run a bare wire from the socket center post through pin 6 to the adjacent ground lug. Solder all three connections.
- () Bring the other driver transformer lead on the side having two blue leads, around the audio shield plate and cut the lead to a length that will reach pins 7 and 8 of the 12BY7 socket. Strip the lead for 1/2" and run through pin 7 to pin 8. Solder both connections.
- () Connect a black wire from pin 4 of the 12BY7 socket (S) to pin 7 of the first 1625 socket (NS).
- () Connect a black wire from pin 5 of the 12BY7 socket (S) to pin 1 of the same 1625 socket (NS).

CAUTION: This completes most of the speech amplifier and audio driver wiring. After the chassis top is mounted to the chassis base, this section will be nearly inaccessible. Consequently it is imperative that everything in the circuit is properly connected. All connections should be checked to be sure they are in the right place, that no shorts to ground or to other leads occur and that the proper components are in the correct place with none left out and all connections soldered. If an ohmmeter is available, a check of the resistors and connections would be advisable. The cathode bypass electrolytics must be correctly polarized.

- () On the far side of the driver transformer are a black and two green wires. Connect either green lead to pin 5 of the front 1625 socket (NS).
- () Connect the other green lead to pin 5 of the rear 1625 socket (NS).
- () On both 1625 sockets, connect a 1 K Ω 1/2 watt resistor (brown-black-red) from pin 5 (S) to pin 4 (S).
- () Connect a black wire from pin 7 of the front 1625 socket (NS) to pin 7 of the rear 1625 socket (NS).
- () Connect a black wire from pin 1 of the front 1625 socket (S) to pin 1 of the rear 1625 socket (NS).
- () Connect a blue wire from pin 6 of the front 1625 socket (S) to pin 6 of the rear 1625 socket (NS). NOTE: These wires must be kept close against the sockets to clear the base frame when the chassis is assembled.
- () Connect a 0.1 Ω shunt resistor from pin 6 of the rear 1625 socket (NS) to pin 2 of the same socket (NS).
- () Connect a brown wire from pin 3 of the front 1625 socket (NS) to pin 3 of the rear 1625 socket (NS). Run the wire under the green transformer lead and clear of the 3/8" grommet.

OSCILLATOR STAGE WIRING

- () Unwind 3/8" of wire at one end of a 4 3/4" long Spirashield and connect the end to ground lug 1 on the 12BY7 oscillator socket (S). Spirashield is a shielding material resembling a tightly wound spring.
- () Slide a 1 1/2" length of large insulated tubing over the Spirashield to the point shown in Pictorial 3.

- () Unwind 3/8" at the other end of the Spirashield and connect to the solder lug near the 5/16" grommet (S).
- () Strip both ends of a green wire 7 1/4" long. Slide it through the Spirashield and connect one end to pin 2 of the 12BY7 socket (NS). Leave the other end free.
- () Cut both leads of a 100 K Ω 1/2 watt resistor (brown-black-yellow) to 1/2" length. Connect one lead to pin 2 (S) and the other lead to ground lug 2 on the 12BY7 socket (NS).
- () Cut both leads of a .005 μ fd disc ceramic capacitor to 1/2". Connect one lead to pin 1 (NS) and the other lead to pin 3 (NS).
- () Connect a bare wire from pin 3 (S) to the same ground lug (S).
- () Connect a blue wire to pin 1 of the 12BY7 socket (S).
- () Run the wire as shown in Pictorial 3 through the 3/8" grommet to lug 2 of the 5-lug terminal strip on top of the chassis (NS). See Pictorial 4.
- () Run a bare wire from the socket center post (S) through pin 6 (NS) to ground lug 3 (S).
- () Connect one lead of a .005 μ fd disc ceramic capacitor to pin 6 (S).
- () Run the other lead through pin 5 (S) to pin 4 (NS).
- () Connect a black wire to pin 4 (S). Run the wire in the same manner as the blue wire through the grommet to lug 5 of the 5-lug terminal strip on top of the chassis (NS).
- () Examine Pictorial 3 and note the placement of the 47 K Ω 1/2 watt resistor (yellow-violet-orange) on the oscillator coils. Run one lead of the resistor through terminal 2 (red dot) of the smallest coil (S) to pin 7 of the 12BY7 socket (NS). Run the other lead of the resistor to terminal 1 of the larger coil (NS).
- () Run a bare wire through terminal 1 of the smaller coil to terminal 2 of the larger coil. Solder both connections and leave 3 1/2" of wire extending past terminal 1 of the smaller coil.
- () Connect one end of an orange wire to pin 8 of the 12BY7 socket (S). Run the wire as shown in Pictorial 3 and connect the other end to lug 3 of the terminal strip in front of the oscillator coils (NS).
- () Connect one end of an orange wire to the same lug (NS) and the other end to lug 1 of the 3-lug terminal strip near the 5/16" grommet (NS). Run the wire under the Spirashield.
- () Connect the black wire coming through the hole from the crystal sockets to lug 3 of the terminal strip near the 5/16" grommet (NS).
- () Connect a .001 μ fd mica capacitor (brown-black-red) from lug 1 (S) to lug 3 (S) of the same strip. CAUTION: Do not use the .001 μ fd 2000 volt mica capacitors until called for.
- () Connect a .005 μ fd disc ceramic capacitor from lug 2 (S) to lug 1 (NS) of the terminal strip in front of the oscillator coils. Bend lug 2 down slightly to clear the 10 mh RF choke which will be mounted later.
- () Connect a red wire to lug 1 of the same strip (NS). Run the wire under the Spirashield as shown, to the 1-lug terminal strip adjacent to the driver RF choke (NS). See Pictorial 3.
- () Connect a .005 μ fd disc ceramic capacitor from the 1-lug terminal strip (NS) to the adjacent solder lug (S).
- () Connect a red wire to lug 1 of the terminal strip near the oscillator coils (NS). Run the wire through the adjacent grommet to lug 1 of the 4-lug terminal strip near the crystal sockets on top of the chassis. See Pictorial 4. Leave sufficient wire to clear the VFO switch which will be mounted later (NS).
- () On the terminal strip in front of the oscillator coils, connect a 27 K Ω 2 watt resistor (red-violet-orange) from lug 3 (S) to lug 1 (NS).
- () Connect a 10 mh RF choke from lug 1 of the same terminal strip (S) to terminal 1 of the larger oscillator coil (NS). Position this choke as shown. It must clear the loading switch shaft.
- () Connect a 3" length of bare wire to terminal 1 of this oscillator coil (S). Leave the other end free.
- () Cut both leads of a 47 μ mf mica capacitor (yellow-violet-black) to 1 1/4" length and slip 1" lengths of sleeving over each lead. Connect one lead to pin 7 of the 12BY7 socket (S).
- () Connect the other lead to pin 9 of the 5763 socket (S). Position the capacitor to clear the 3/4" hole between sockets as shown in Pictorial 3.

This completes the oscillator tube wiring.

DRIVER STAGE WIRING

- () Connect 1.02 Ω meter shunt resistor from pin 7 of the 5763 socket (NS) to ground lug 4 (S). Position as shown.
- () Cut both leads of a .005 μ fd disc ceramic capacitor to 3/8". Connect one lead to pin 7 (NS) and the other lead to ground lug 3 (NS).
- () Cut both leads of a .005 μ fd disc ceramic capacitor to 3/8" length. Connect one lead to ground lug 3 (NS) and the other lead to pin 6 (NS).
- () Strip both ends of an orange wire 3 1/4" long. Connect one end to pin 6 (S). Leave the other end free.
- () Cut both leads of a .005 μ fd disc ceramic capacitor to 1/2" length. Connect one lead to ground lug 3 (S) and the other lead to pin 4 (NS).

- () Run a bare wire from pin 5 (S) to the socket center post (NS).
- () Run a bare wire from the socket center post through pin 3 to ground lug 2. Solder all three connections including the wire from pin 5.
- () Connect a 1 3/8" bare wire from the bottom terminal of the 2 1/2 mh RF choke (S) to pin 1 (NS). Be sure this lead clears all other connections.
- () Cut one lead of a .001 μ fd mica capacitor (brown-black-red) to 1/2" length and connect to pin 1 (S). Run the other lead through the nearby 3/8" grommet.

- () Cover one lead of a 27 K Ω 1 watt resistor (red-violet-orange) with a 3/4" length of sleeving as shown in Pictorial 3 and connect to pin 8 (S). Leave the other end free.
- () Connect a bare wire to the top terminal of the 2 1/2 mh RF choke (S) and connect the other end to the adjacent 1-lug terminal strip (NS). Be sure the lead touches nothing else.
- () Connect one end of a red wire 3 1/4" long to the same point (NS). Leave the other end free.
- () Cut one lead of a 6500 Ω 7-watt resistor to 1". Bend as shown and connect to the same point (S). Leave the other end free.

This completes most of the driver stage wiring.

NOTE: The low voltage power transformer and modulation transformer will be mounted at this time. This will form a base allowing the chassis top to be set on end. In this position most of the top components may be mounted without danger of damage to them during wiring. Cut all transformer leads to an appropriate length before making the indicated connections.

- () Looking from the bottom front of the chassis top, the power transformer mounts in the right rear corner with the leads coming through the two 3/4" holes. The six 7/32" holes are for the 8-32 mounting screws. In mounting, use three 8-32 screws with lockwashers and nuts in the holes closest to the chassis center and just one screw in a hole near the edge. This last screw must be removed when the chassis is assembled. Center the transformer with all mounting holes before tightening. The three screws near the large chassis holes will not be removed again so be sure they are well tightened. See Pictorial 3.

- () On top of the chassis and forward of the power transformer are two 5/8" holes near the chassis edge. The leads from the modulation transformer pass through these holes and the transformer is secured using 8-32 screws, lockwashers and nuts through the four nearby 7/32" holes. On the rear center mounting screw, substitute a #10 solder lug in place of the lockwasher. Align the transformer before tightening. Use all four screws here.
- () Slip a 3 1/4" length of large insulated tubing over the brown and blue leads of the modulation transformer which come through the front chassis hole. Guide the tubing and leads around the driver transformer and through the 3/8" grommet near the 1625 tube sockets. The other modulation transformer leads will be connected later.

- () On the power transformer are two green, two brown, two yellow and one brown with a yellow stripe coming through the rear chassis hole. Separate the two yellow leads and connect either one to pin 2 of the 5V4 ceramic octal wafer socket (S).
- () Connect the other yellow lead to pin 8 of the 5V4 socket (NS).
- () The transformer leads emerging from the front chassis hole consist of two red, two black, two red with blue stripes and one red with a yellow stripe. Separate the two red leads and connect either one to pin 4 of the 5V4 socket (S).

- () Connect the other red lead to pin 6 of the 5V4 socket (S). Run this lead under the two yellow leads.
- () Separate the two red and blue striped leads and connect either one to pin 1 of the 6AL5 socket (the rear 7-pin miniature socket) (S).
- () Connect the other red and blue lead to pin 5 of the 6AL5 socket (S).
- () Run a bare wire from pin 7 of the 6AL5 socket through pin 2 and allow 1 1/2" to extend past pin 2. Be sure the wire will clear pin 1 and solder pin 7 and pin 2. Leave the end protruding past pin 2 free.
- () Run a bare wire from pin 4 of the 6AL5 socket through pin 4 of the OA2 socket (front 7-pin miniature socket) through pin 7 of the OA2 socket. Leave 2 3/4" of wire extending past pin 7 of the OA2 socket and solder all connections.
- () Connect a 15 K Ω 5 watt resistor from pin 1 of the OA2 socket (S) to pin 5 of the 5V4 socket (NS). Position as shown in Pictorial 3.
- () Mount a 20-20-20 μ fd 450 volt electrolytic capacitor to the capacitor mounting wafer next to the 5V4 socket. Insert the capacitor through the mounting plate in the position shown and twist the mounting prongs to secure it.
- () Connect a bare wire to pin 5 of the 5V4 socket (S). Slide a 1" length of sleeving over the wire and wrap it once around the \blacksquare marked terminal (NS) and over to the \blacktriangle marked terminal (NS).
- () Connect a bare wire to pin 8 of the 5V4 socket (S). Slide a 1 1/4" length of sleeving over the wire and connect to the \blacktriangle marked terminal of the capacitor (NS).
- () Connect a 4" length of green wire to pin 7 of the 6AQ5 socket (S). Strip the other end and leave free for later connection.

PARTIAL WIRING OF THE FINAL AMPLIFIER

- () At the center rear of the chassis are a group of five holes in line, two 5/16" and three 3/8" holes. Refer to Figure 8 and Pictorial 4. Mount two feedthrough insulators in the 5/16" holes. The gaskets furnished with the insulator are placed on each side of the chassis between the metal and the ceramic.
- () On the top and bottom of each feedthrough insulator, mount solder lugs in the positions shown with two on the top of the rear insulator.
- () Mount a standoff insulator in the place shown in Pictorial 4 and include two solder lugs in the positions shown. Straighten out the lug facing to the chassis rear.
- () In line with the standoff insulator and next to the power transformer, mount the 1 mh 500 mill RF choke using 6-32 x 3/8 screw and #6 fiber washer. Position terminals as in Pictorial 4.
- () Mount the driver tank coil over the 3/4" hole at the chassis center, using 1/4" 6-32 hardware. Position the terminals as shown in Pictorial 4 and center the coil over the hole before tightening.
- () Prepare the final tank coil for mounting as follows: Of the three taps protruding out from the side of the coil, cut the two outside ones to a length of 2 1/8" from the plastic coil support. Cut the center lead to 1 7/8". Grasp about 1/8" of wire at the end of each lead with long nosed pliers and form an open hook by twisting the pliers sharply.
- () Mount the final amplifier plate coil by connecting the ends to the solder lugs on top of the feedthrough insulators. Adjust the coil until the three taps are centered in the 3/8" chassis holes. Then solder the coil ends to the solder lugs. Take care in soldering to prevent damage to the plastic coil form. On the under side of the chassis and at a distance of about 1/4" from the surface, bend the taps in the approximate positions shown in Pictorial 3. This will make it easier later to make the switch connections.
- () Mount the 10 meter plate coil by bending the solder lug at the rear feedthrough insulator around the short end of the coil. Then bring the long end of the coil over to the straightened lug on the standoff insulator. Make sure this coil clears the large holes in the chassis and solder both connections.
- () Connect a .001 μ fd 2000 volt mica capacitor from the remaining solder lug on the standoff insulator (S) to the terminal on top of the RF choke (NS). Bend the leads to place the capacitor as shown in Pictorial 4.

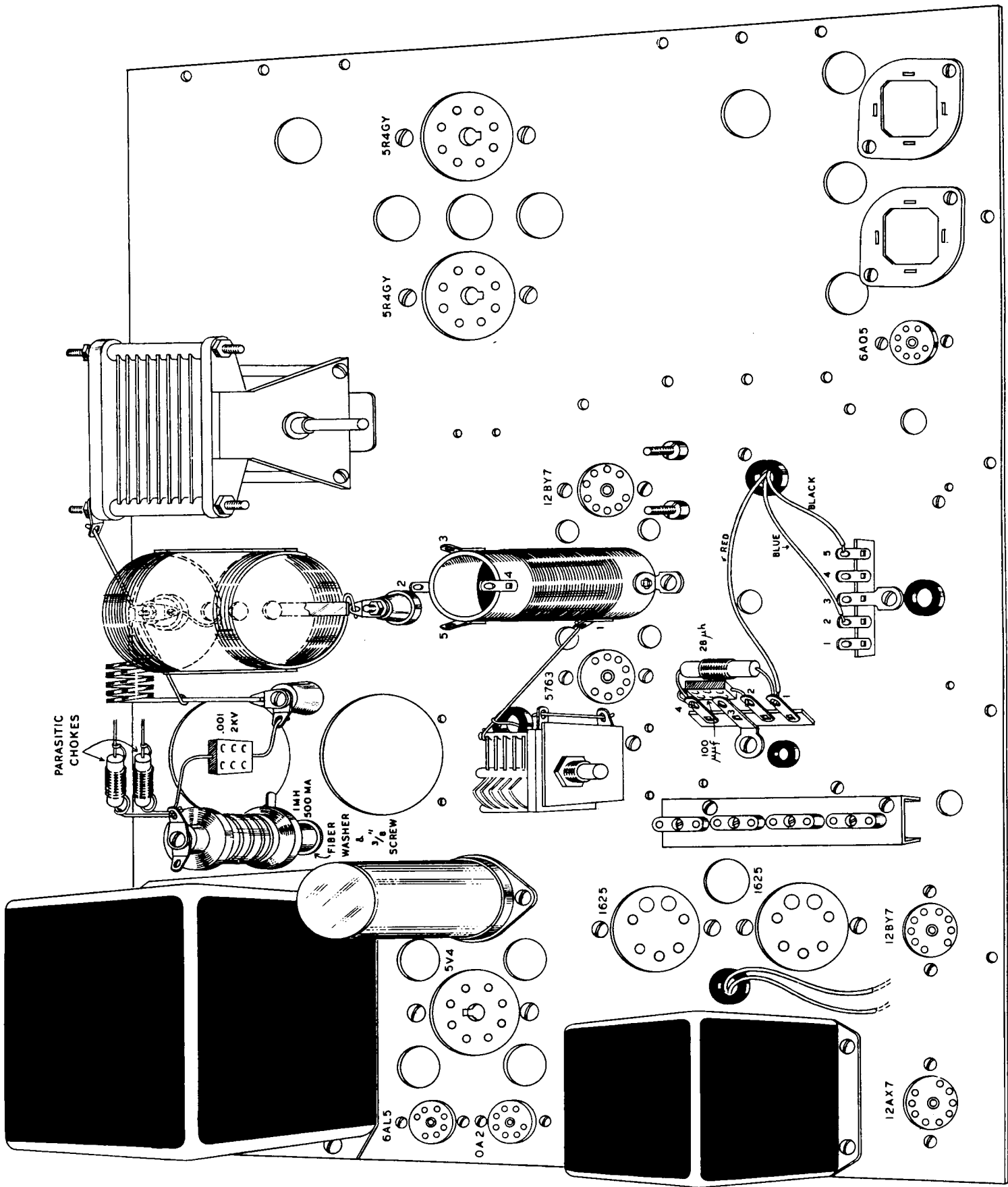

PICTORIAL 4

- () Cut one lead on each of the two parasitic chokes ($47\ \Omega$ 2 watt resistor with 5 turn coil) to 1" length and connect these leads to the top terminal of the RF choke (S). Leave the other ends free.
- () Slip the piece of silver plated strip through the slot on the chassis next to the tank coil and align the hole in the strip with the hole next to the slot.
- () Mount the main tuning condenser with the silver strip between the rear foot of the capacitor and the chassis. In mounting the capacitor, use $3/8$ " 6-32 screws with lockwashers under the screwheads as well as under the nuts. On the underside of the chassis, the silver strip and two solder lugs are secured with the front mounting screw of the tuning capacitor.
- () Mount a solder lug on the left stator terminal of the tuning capacitor and position as shown.
- () Connect a heavy bare wire (number 14) from this solder lug to the long lead of the 10 meter coil. Wrap the bare wire around the 10 meter coil lead and arrange the wire to clear both coils. Solder both connections.
- () Mount the driver tuning capacitor to the mounting bracket next to the 5763 socket. Use a $3/8$ " lockwasher behind the bracket and a $3/8$ " nut in front.
- () Connect a heavy bare wire from the solder lug on the bracket (S) to the rotor terminal of the capacitor (S).
- () Connect a heavy bare wire to driver coil terminal 1 (S). Arrange this wire to clear the 5763 socket and connect to the rear driver capacitor stator terminal (S).
- () Connect the .001 μ f capacitor lead coming through the chassis at this point to the heavy wire (S).
- () On the terminal strip next to the crystal sockets, connect a 100 μ f mica capacitor (brown-black-brown) from lug 2 (NS) to lug 4 (NS).
- () On the same terminal strip, connect a 28 μ h choke from lug 1 (S) to lug 4 (NS).

ASSEMBLY OF CHASSIS TOP-PLATE AND BASE

NOTE: Set the chassis top-plate upside down on the bench with the audio section toward the front right. The two transformers will support one side. A block of sufficient height or the high voltage transformer should be placed under the other side to allow the coils to clear the bench while working with the chassis.

The loose transformer leads can be temporarily inserted in the ventilation holes near the 5V4 socket to keep them out of the way. All other leads should be extended straight up to clear the chassis frame and the leads along the side of the 1625 sockets must be run close to the sockets.

During the assembly operation, it will be necessary to guide the chassis base onto the top carefully to prevent component damage and to make sure that none of the wires get squeezed between two sections. The twenty-one $7/32$ " holes around the perimeter of the chassis base should be placed toward the bottom side of the chassis top-plate. These holes are used to bolt the two sections together.

- () Remove the single 8-32 screw holding the outside edge of the power transformer.
- () As the chassis frame is lowered on the top plate, guide the long cable wires at point 5 through the $3/8$ " hole adjacent to the audio section.
- () Using 8-32 screws, with lockwashers under the nuts, bolt the chassis top to the chassis base. The screws pass through the holes along the edge of the chassis base frame. All screws except the six along the left side flange should be inserted before any are tightened. The six screws mentioned hold one side of the high voltage transformer and filter choke and are omitted until these parts are mounted. However, these holes must be aligned before tightening the other side. The cable near the low voltage transformer may be moved to allow access to the three nuts at that point.
- () When all but the six high voltage transformer and choke mounting screws are in, tighten a few to maintain alignment. Now the entire unit can be placed on its end with the transformers supporting it, while the rest of the screws are tightened.

WIRING IN THE MODULATOR-POWER SUPPLY COMPARTMENT

NOTE: Refer to Pictorial 5 on Page 28 for this portion of the wiring.

- () Cut either black lead coming from the power transformer to 3 1/2", stripping the end to 5/16". Connect this lead to lug 4 on terminal strip BB (S) pressing the lead down against the chassis.
- () The brown-yellow lead coming from the rear hole of the power transformer should be cut to 2 1/4", stripped back 5/16" and connected to lug 3 of BB (S).
- () The other black lead from the power transformer should be cut to 4 1/2", stripped back 5/16" and connected to lug 1 of BB (S). Position this lead away from strip CC and along strip BB.
- () At this point a visual inspection should be made to eliminate the possibility of shorts or grounds in any of the wiring just completed.
- () Cut both green leads to 3" and strip back 5/16". Connect either lead to lug 5 of strip CC (S). Connect the other green lead to lug 4 on CC (S). These are high voltage terminals, so special care is required in wiring and soldering to provide maximum clearance between terminals and between each terminal and ground.
- () Cut the red-yellow lead from the power transformer to a length of 2 1/4" and strip back 5/16". Connect this wire to lug 3 of strip CC (S).
- () Cut the two remaining (brown) leads from the power transformer to a length of 3 1/4" and strip back 5/16". Connect either lead to lug 2 on CC (S). Connect the other lead to lug 1 of CC (NS). Now recheck your work for the preceding three steps to avoid any accidental shorts or grounds.
- () Cut a black wire to 5 1/8" and strip both ends. Connect it from pin 3 of the 6AL5 socket (S) to lug 1 of strip CC (S). Position as shown in Pictorial 5.
- () Referring now to the filter choke, connect either choke lead to the ▲ terminal of the filter capacitor, running the lead close to the chassis (S). Connect the other choke lead to the ■ terminal of the filter capacitor (S). Run this lead under the lead from pin 8 of the rectifier and against the chassis.
- () Slip a 5/8" length of sleeving over the bare wire coming from pin 2 of the 6AL5 socket. Connect this lead to lug 3 of strip DD (S).
- () Connect the bare wire coming from pin 7 of the OA2 socket to lug 2 of terminal strip EE (S). Position as shown to clear adjacent terminals.
- () Connect the orange lead at point 7 of the cable to pin 5 of the OA2 socket (S).
- () Connect the red lead at point 7 of the cable to pin 3 of the 5V4 socket (NS).
- () Cut the remaining driver transformer lead (black) to 8" and connect to lug 1 on strip EE (S).
- () Referring now to the leads of the modulation transformer coming through the chassis hole adjacent to strip GG, connect the red lead to lug 5 of strip FF, cutting to the appropriate length (NS). Connect a 1 megohm 2 watt precision resistor from lug 5 of FF (NS) to pin 3 of the 5V4 socket (S). Connect a jumper from 5 to 4 of FF. Solder lug 5.
- () Connect the yellow wire to lug 4 of FF, after cutting to appropriate length (S).
- () Connect the black lead to lug 3 of FF in the same manner (S).
- () Connect the green lead to lug 2 of FF in the same manner (NS).
- () Connect the short jumper lead from lug 2 (S) to lug 1 (S) of strip FF.
- () High potentials are involved in the preceding connections. Inspect your work for accidental shorts or grounds.
- () The red lead at point 6 of the cable may now be connected to the outside unsoldered lug on the audio shield plate terminal strip (S). Refer to Pictorial 5 for this connection.
- () Also at point 6 of the cable is a black lead and a black and white lead. Connect both of these leads to pin 7 of the front 1625 socket (S).
- () At point 8 of the cable, connect the black lead to pin 1 of the rear 1625 socket (NS).

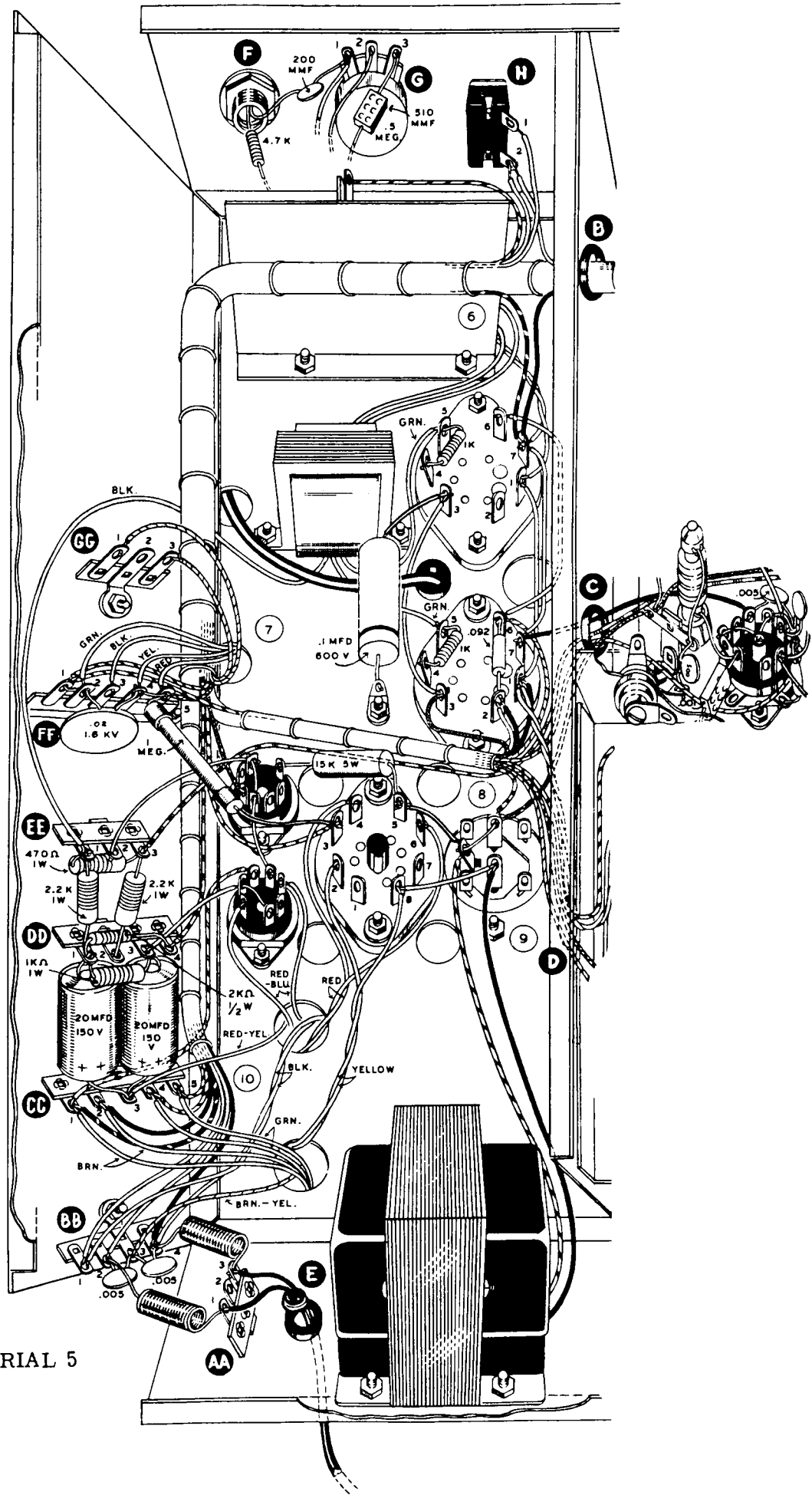

PICTORIAL 5

- () Connect two 8" black wires in parallel by twisting them together along their lengths and at the stripped ends. This increases the current carrying capacity for the filaments of the 6146 tubes. Connect one end of the pair to pin 1 of the rear 1625 socket (S) and pass the other end under the cable and through the 3/4" grommet D.
- () Cut and strip a 5 1/2" black lead. Connect one end to pin 7 of the rear 1625 socket (S) and pass the other end through grommet C to pin 4 of the 5763 socket in the RF compartment. Position as shown in Pictorial 5 (S).
- () Select a .1 μ fd 600 volt capacitor and connect it between pin 3 of the front 1625 socket (S) and the ground lug on the rear modulation transformer mounting screw (S).
- () Connect the gray lead at point 8 of the cable to pin 3 of the rear 1625 socket (S).
- () Still at point 8, connect the blue lead to pin 6 on the rear 1625 socket (S).
- () Connect the brown lead and the white lead to pin 2 of the rear 1625 socket (S).
- () Connect the red lead to the \blacktriangle terminal of the filter condenser (NS).
- () Feed the red lead from the terminal strip in the RF compartment through grommet C and connect to the \blacktriangle terminal of the filter condenser (S).
- () While in the RF compartment, connect the yellow lead from point 8 of the cable to pin 7 of the 5763 socket (S). Run this lead clear of the 3/8" grommet and against the chassis.
- () Connect one end of a green wire 10" long to lug 3 of terminal strip EE (S). Run this wire under the 1 megohm precision resistor along the cable and through grommet C. Leave the other end free.

NOTE: With the exception of the microphone input, audio gain control and power cord, this completes the wiring in the modulator-power supply compartment.

WIRING IN THE HIGH VOLTAGE POWER SUPPLY COMPARTMENT

NOTE: Refer to Pictorial 6 on Page 30 for this portion of the wiring. Use hardware in package #3 for the following assembly.

- () Mount the high voltage transformer on top of the chassis next to the main tuning capacitor. Use 8-32 hardware and tighten all six screws securely.
- () Mount the HV filter choke on top of the chassis just behind the filter capacitor socket wafers. Use 8-32 hardware and tighten securely.
- () Mount the two 125 μ fd filter capacitors with the terminals positioned as shown in Pictorial 6. Secure by inserting the prongs in the slots in the wafer and twisting. NOTE: Prongs or capacitor case must not touch the chassis at any point.
- () Place the chassis on its rear apron and the transformers will hold it upright. The high voltage power supply compartment should now be on your right.
- () The bare wire coming from terminal 2 of the double-pole single-throw switch should pass through the nearby ground solder lug, to pin 3 on the 6AQ5 socket. Solder both connections.
- () Connect a brown wire from pin 2 of the 6AQ5 (S) to the Y-prong of the right-hand filter capacitor (NS).
NOTE: The cable may be pushed out of the way temporarily to permit access to the tube socket.
- () At point 3 of the cable, connect the orange lead through pin 5 to pin 6 of the 6AQ5 socket. Solder both connections.
- () The black lead at cable point 3 should be connected to pin 4 of the 6AQ5 socket (S).
- () Connect the two brown leads to the Y-prong of the right-hand filter capacitor as shown in Pictorial 6 (S).
NOTE: Here again, care should be exercised to prevent any accidental grounding of the capacitor case. The capacitor cases are at radically different potentials. An error in capacitor identification or associated wiring at this point will damage circuit components.
- () Connect a 2 1/2" bare wire to the Z mounting prong of the same filter capacitor (S) as shown in Pictorial 6. Leave the other end free.

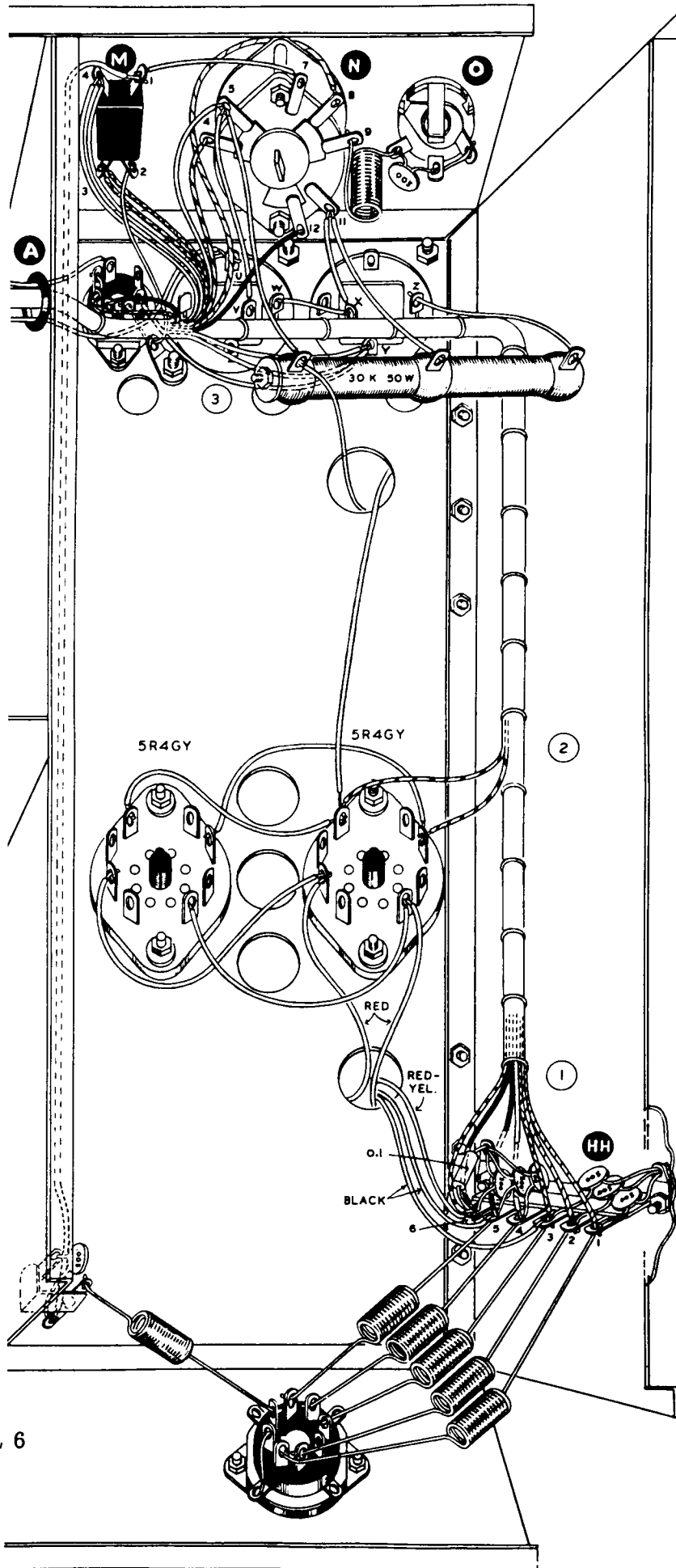

PICTORIAL 6

- () Refer to the pictorial diagram for the position of the following wire. Start a bare wire through terminal 11 of the phone-CW switch. Slip a 3/4" length of sleeving over the wire, pass the wire through the X capacitor terminal and then slip a 3/4" length of sleeving over the wire. The end of the wire should then be connected to the W mounting prong of the filter capacitor on the left. Leave 1 3/4" of bare wire sticking out from terminal 11 of the switch. Solder all three connections.
- () Connect a 6" red lead from the U-prong on the left-hand filter capacitor (S) (see Pictorial 6) through grommet A and leave the other end free.
- () Pass a bare wire through switch terminal 5 of the phone-CW switch and slip a 1 3/4" length of sleeving over the end as it comes through. Connect the end to the V terminal of the left hand filter capacitor. See Pictorial 6 for this connection. Solder both terminals and leave 2" of wire extending from switch terminal 5.
- () Mount the 50 watt, 30 K Ω center-tapped bleeder resistor to the side chassis apron as shown in Pictorial 6. Use the 4 1/2" 10-24 bolt with a 5/8" fiber washer on the threaded end.
- () The bare wire from the Z-prong right-hand capacitor should now be connected to the right terminal of the bleeder resistor (S).
- () Slip a 1 1/4" length of sleeving over the bare wire coming from switch terminal 11 and connect to the center bleeder resistor terminal (S).
- () Slip a 1 3/8" length of sleeving over the bare wire from switch terminal 5 and connect to the left bleeder terminal (NS).
- () Cut the red or black lead of the filter choke to the proper length and connect to the left hand bleeder terminal (S).
- () There is a short red lead and a long red lead at point 2 of the cable. Connect the short lead to pin 2 of the right hand 5R4GY socket (NS) and the long lead to pin 8 of the same socket (NS).
- () Connect a bare wire to pin 2 of this same socket (S) and slip a 3 1/4" length of sleeving over the wire. Connect the other end to pin 2 of the left hand 5R4GY socket (S).
- () Connect a bare wire to pin 8 of the left hand 5R4GY socket (S) and run it through a 2 3/4" length of sleeving to pin 8 of the right hand 5R4GY socket (NS).
- () Cut the remaining choke coil lead to an appropriate length and connect to pin 8 of the right hand 5R4GY socket (S).
- () Referring now to the power transformer, cut either red lead to an appropriate length to reach pin 4 of the right hand 5R4GY socket (NS). NOTE: Save the remaining piece of transformer lead and use it to connect this terminal to pin 4 of the left hand 5R4GY socket. Solder both terminals.
- () Cut the other red transformer lead to the proper length to reach pin 6 of the right hand 5R4GY socket (NS). NOTE: Use the remaining piece of wire to connect this terminal to pin 6 of the left hand 5R4GY socket. Solder both terminals.
- () Cut the red-yellow transformer lead to an appropriate length to reach lug 6 of strip HH down in the lower right corner of this compartment (S).
- () Cut to size and connect either black lead from the transformer to lug 5 on strip HH (S).
- () Cut to size and connect the other black lead to lug 3 of strip HH (S).
- () At this point, a careful visual inspection is in order. This compartment contains wiring of the high voltage power supply and the power line voltage. Make doubly sure that there are no shorts or grounds and the components such as the line filter chokes do not touch one another. Damage to expensive circuit components can result if care is not exercised in wiring and positioning parts.

This completes most of the wiring in the high voltage compartment.

ASSEMBLY AND WIRING OF 6146 SUB-CHASSIS

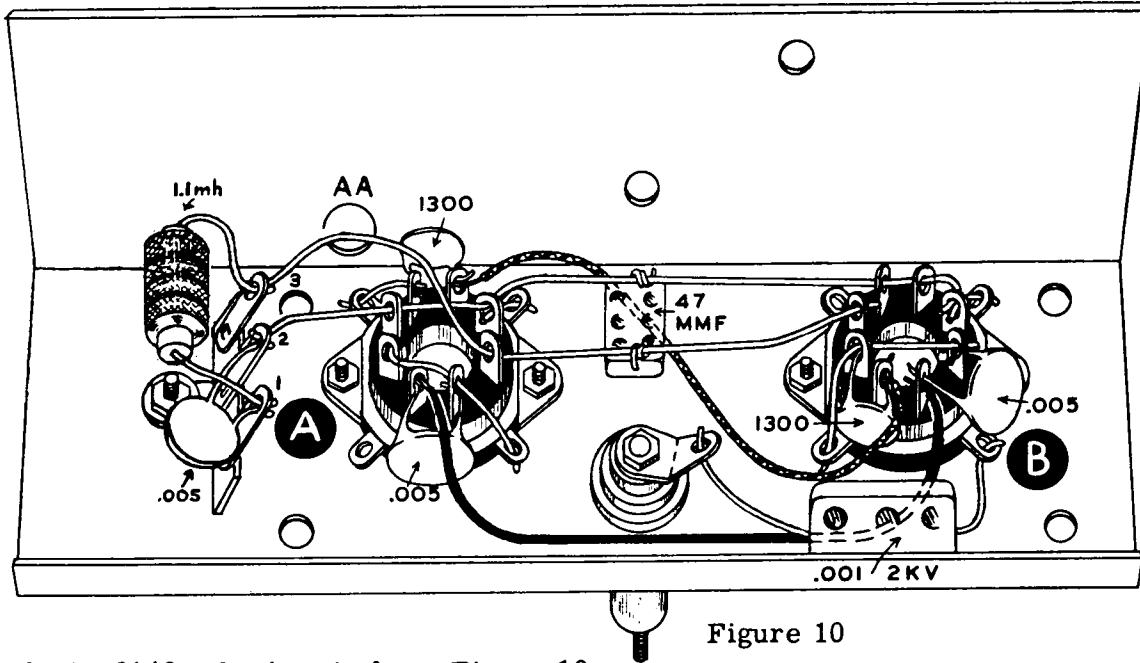

Figure 10

- () Identify the 6146 sub-chassis from Figure 10.
- () Mount two ceramic octal saddle-type sockets on the sub-chassis with the keyways facing away from each other. Use 1/4" 6-32 screws, lockwashers and nuts. See Figure 10.
- () Mount a feed-through insulator in the 5/16" hole. Arrange the stud in the insulator so most of it projects through the top. Leave only enough of the stud at the bottom of the insulator to hold a solder lug and two nuts. See Figure 10 and position the insulator body and solder lug as shown.
- () Mount a 3-lug terminal strip in the hole to the left of socket A. NOTE: In each socket pin are two holes. When connecting the small capacitors use the holes nearest to the ceramic portion of the socket. Cut the leads just long enough to make the indicated connections.
- () Connect a .005 μfd disc ceramic capacitor from pin 6 (NS) to pin 7 (NS) of socket A.
- () Connect a .005 μfd disc ceramic capacitor from pin 1 (NS) to pin 2 (NS) of socket B. Position the capacitor to clear the adjacent ground lug.
- () Connect a 1300 $\mu\mu\text{f}$ disc ceramic capacitor from pin 2 (NS) to pin 3 (NS) of socket A.
- () Connect a 1300 $\mu\mu\text{f}$ disc ceramic capacitor from pin 3 (NS) to pin 4 (NS) of socket B.
- () Connect a .005 μfd disc ceramic capacitor from lug 1 (NS) to lug 2 (NS) of the terminal strip.
- () Connect an orange lead from pin 3 of socket A (NS) to pin 3 of socket B (NS). Run the lead close to the chassis.
- () Connect a black lead from pin 7 of socket A (NS) to pin 2 of socket B (S). Run this lead close to the chassis also.
- () Run a heavy bare wire through the following terminals in order (see Figure 10): lug 2 of the strip, pins 1 and 4 of socket A and pins 6, 7 and 8 of socket B. Solder lug 2 of the terminal strip and pins 6 and 7 of socket B.
- () Connect a heavy bare wire from pin 8 of socket B (S) to the adjacent ground lug (S).
- () Run a heavy bare wire through pins 1, 4 and the ground lug adjacent to pin 4 on socket B. Solder all three connections.
- () Connect a heavy bare wire from pin 4 (S) to the adjacent ground lug (S) on socket A.
- () Connect a heavy bare wire from pin 2 (S) to the adjacent ground lug (S) on socket A.
- () Run a heavy bare wire through pin 8, pin 6 and the ground lug near pin 6 on socket A. Solder all three connections.
- () Run a heavy bare wire through lug 3 of terminal strip, pin 5 of socket A and pin 5 of socket B. Bend the wire upward to clear the other bare wire between the terminal strip and socket A. Solder pin 5 on both sockets.

- () Refer to Figure 10 and connect a $47 \mu\mu\text{f}$ mica capacitor (yellow-violet-black) between the two heavy wires as shown. Keep the leads short and solder both connections.
- () Connect a $.001 \mu\text{fd}$ 2000 volt mica capacitor (brown-black-red) from the #1 ground lug on socket B (S) to the feedthrough insulator solder lug (NS).
- () On the terminal strip, connect a 1.1 mh RF choke from lug 1 (NS) to lug 3 (NS).
- () Set this sub-assembly aside temporarily.

WIRING IN THE RF COMPARTMENT

NOTE: Refer to Pictorial 7 on Page 34 for this portion of the wiring.

- () Leave the chassis positioned on its back apron as in the previous group of steps. The RF compartment is in the center with the chassis in this position.
- () At point 4 of the cable, push the two black leads, the blue lead and the orange lead through the adjacent grommet. This will leave a brown, a green and a violet lead remaining.
- () Mount the 500,000 Ω potentiometer in the hole adjacent to the 3-lug terminal strip in the upper right hand corner of this compartment. See Pictorial 7 for the position of the potentiometer terminals.

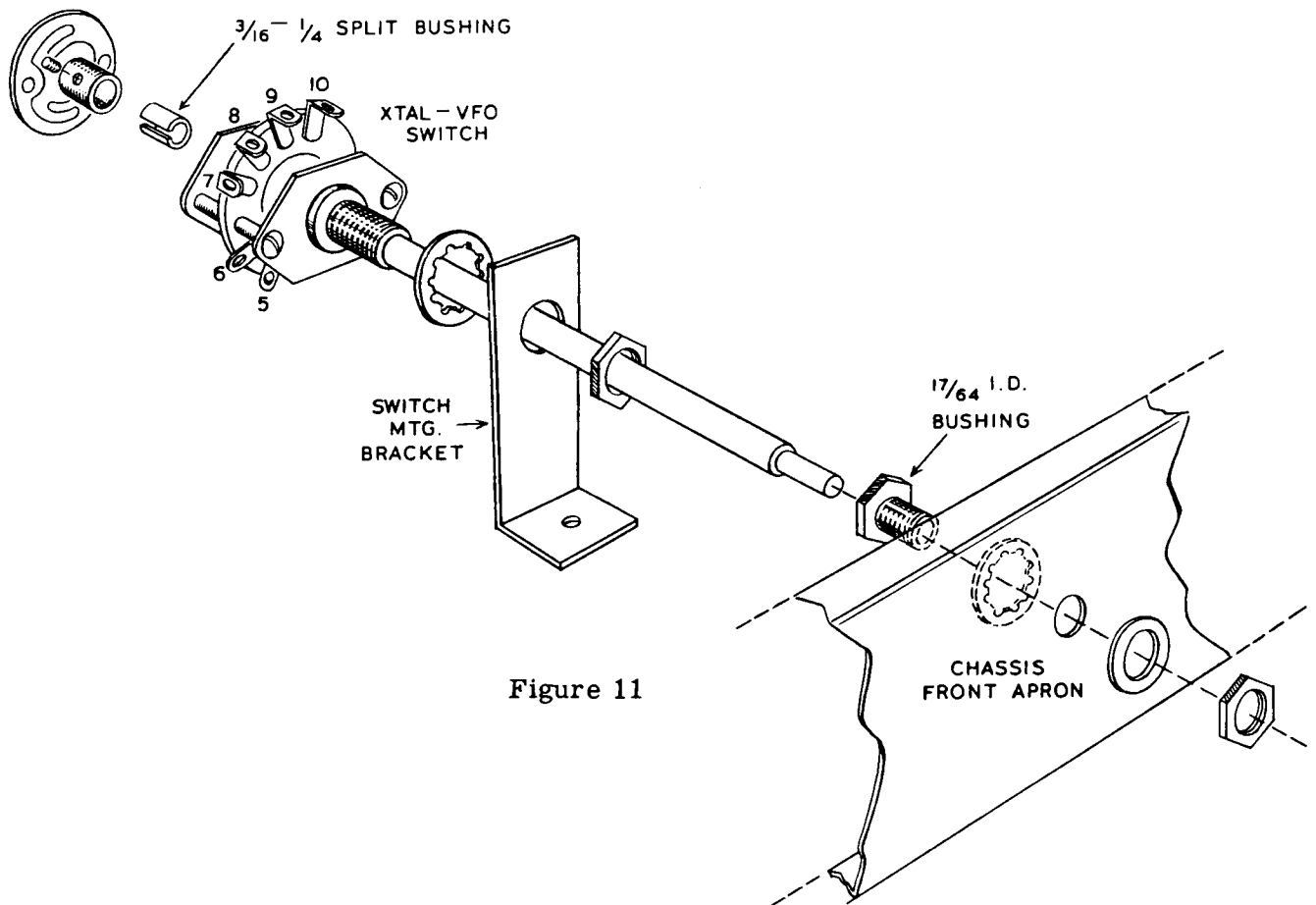
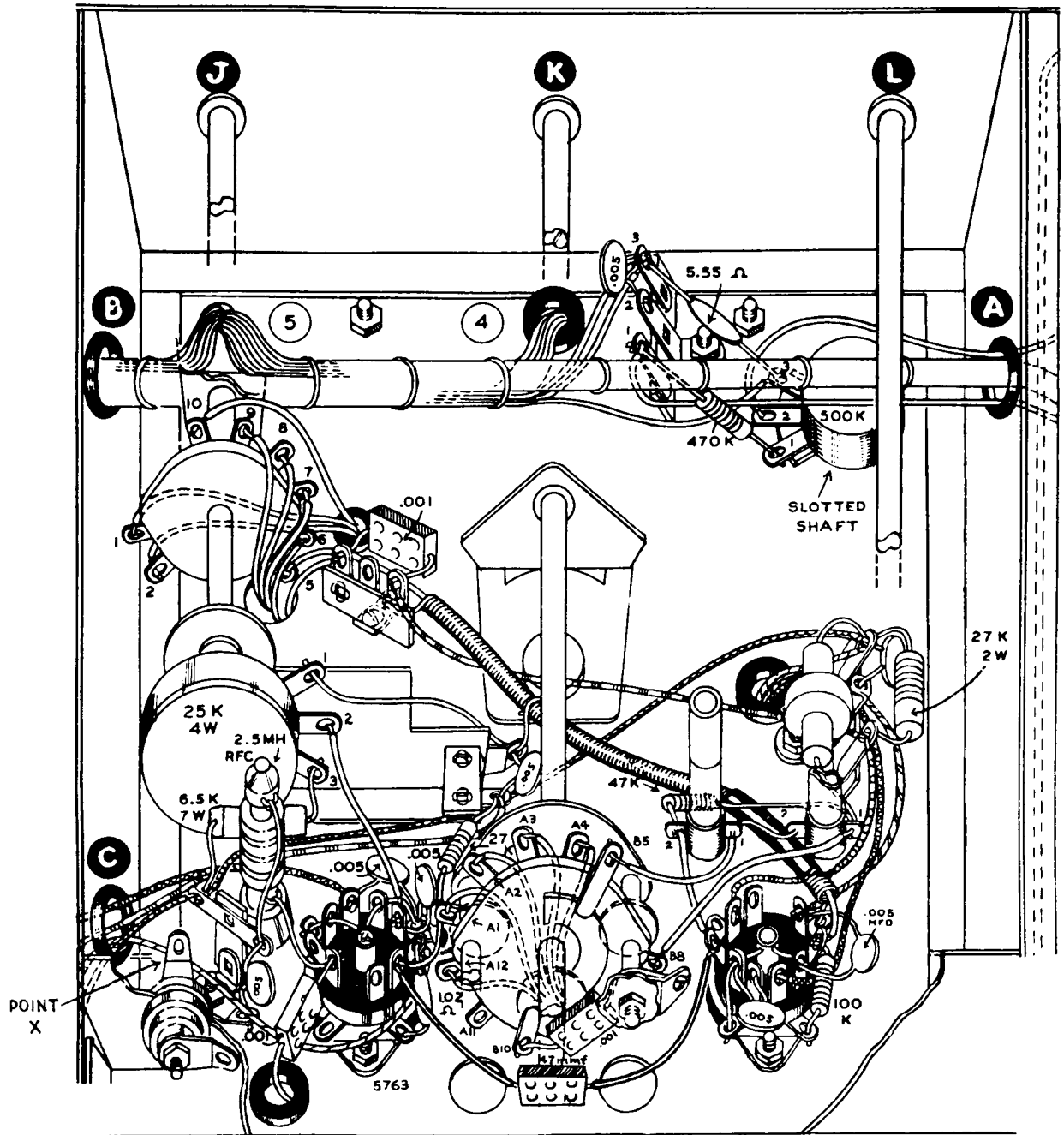
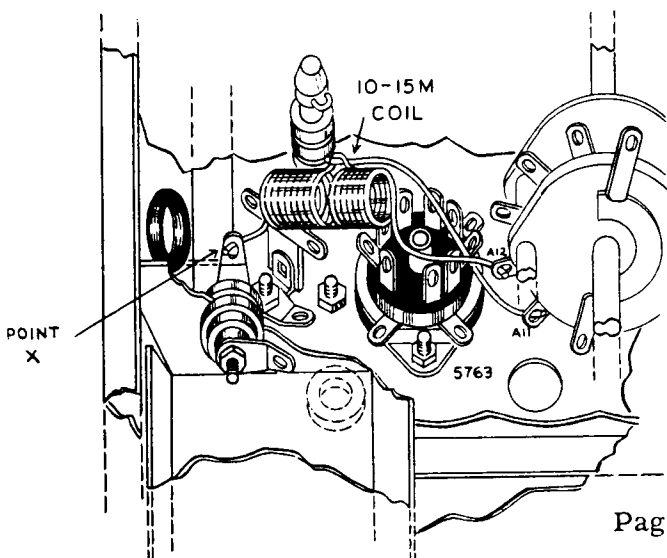

Figure 11

- () Prepare the XTAL-VFO switch for mounting by connecting two $6 \frac{1}{4}$ " blue wires to terminals 1 and 2 (S). Refer to Pictorial 7 for terminal identification.
- () For actual mounting, refer to Figure 11. While mounting the switch, guide the two blue wires through the $\frac{5}{16}$ " grommet adjacent to the switch and leave the other ends free.
- () Connect the green wire coming through the Spirashield to terminal 5 of the XTAL-VFO switch (S).
- () Referring now to the colored leads coming through the chassis from the crystal sockets, connect brown to switch terminal 6, red to terminal 7, orange to terminal 8 and yellow to terminal 9. Solder all four connections.



PICTORIAL 7



- () Strip both ends of a 4 1/4" green wire and connect one end to switch terminal 10 (S). Pass the wire through the 5/16" grommet and leave the other end free.
- () Refer to Figure 12 and mount the driver potentiometer, solder lug and terminal strip on the potentiometer mounting plate as shown.

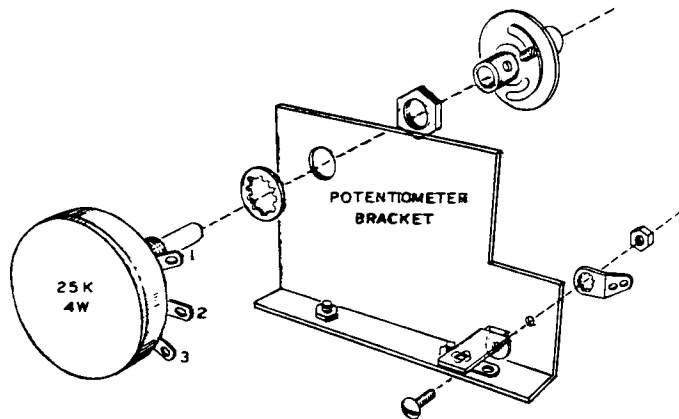
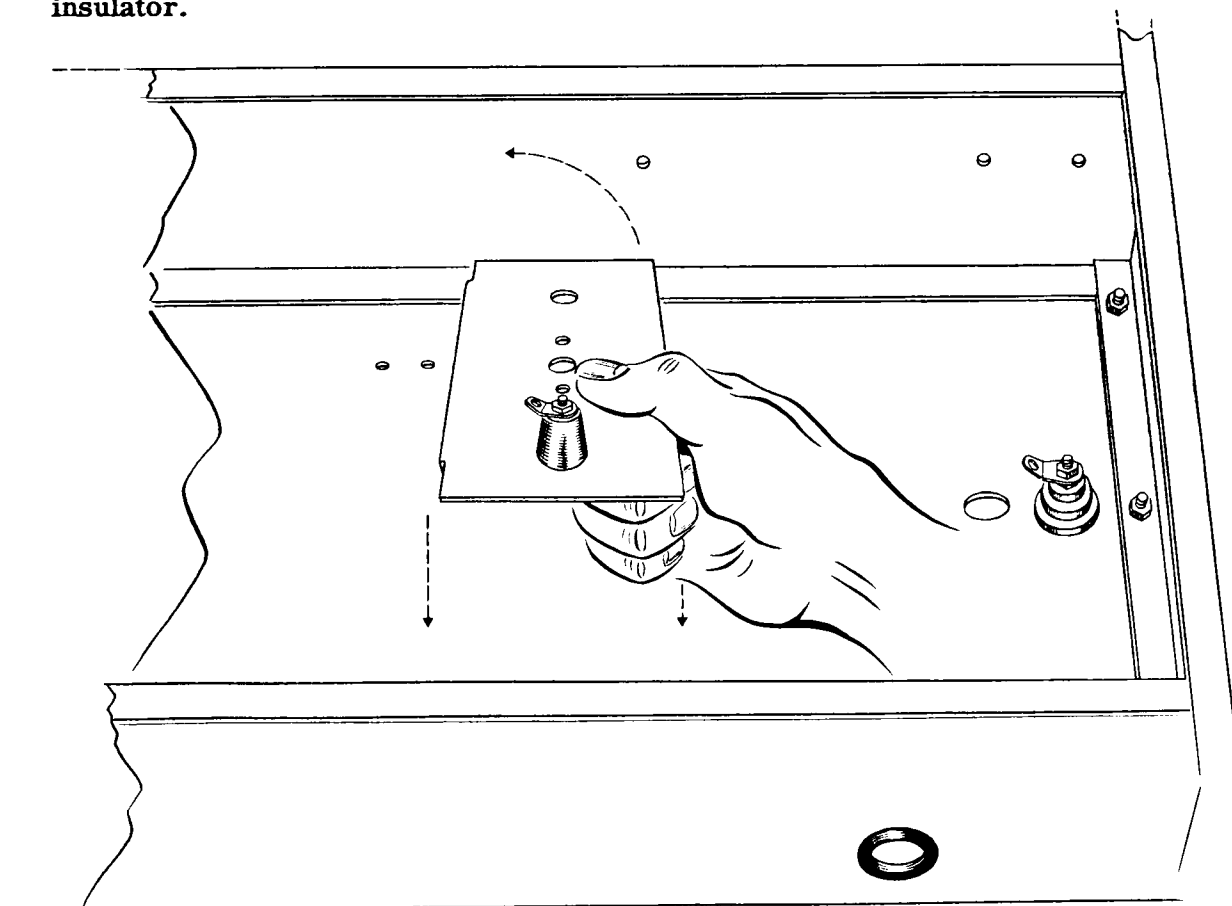

Figure 12

- () Install the mounting plate and potentiometer just in back of the XTAL-VFO switch and couple the two units together as shown in Figure 12. Use the split bushing over the switch shaft to fit the insulated coupler as indicated in Figure 11. Use 6-32 hardware to mount the plate and tighten the plate to the chassis before tightening the coupler set screws. Care should be used to prevent damage to the RF choke immediately behind the potentiometer.
- () Again, refer to Pictorial 7 and connect the free end of the 6.5 K Ω resistor to terminal 3 of the driver potentiometer (S). Position leads as shown.
- () Connect the free end of the orange wire coming from pin 6 of the 5763 socket to terminal 2 of the drive control potentiometer (S).
- () Start a bare wire through the ground lug at the base of the potentiometer mounting plate and loop the end around the Spirashield. Attach the other end of the wire to terminal 1 of the potentiometer. Solder the loop to the Spirashield. Solder the other end to terminal 1 on the potentiometer.
- () Connect a .005 μ fd disc ceramic capacitor from this same solder lug (S) to the adjacent 1-lug terminal strip (NS).
- () Connect the free ends of the green wire and the 27 K Ω resistor to the 1-lug terminal strip (S).
- () Refer now to the clamp potentiometer and the adjacent terminal strip in the upper right hand corner. The violet wire coming out of the cable at point 4 should connect to terminal 3 of the potentiometer (NS).
- () Connect a 5.55 Ω shunt resistor from terminal 3 of the potentiometer (S) to lug 3 of the terminal strip (NS). Arrange this resistor to clear the small hole in the chassis.
- () Connect a .005 μ fd disc ceramic capacitor from lug 2 of the terminal strip (S) to lug 3 of the terminal strip (NS).
- () Connect the brown and green wires at point 4 of the cable to lug 3 of the terminal strip (S).
- () Connect a 470 K Ω resistor (yellow-violet-yellow) from lug 1 of the strip (NS) to terminal 1 on the potentiometer (S).
- () Connect the red wire coming through 3/4" grommet A to lug 1 on the terminal strip (S).
- () Connect the green wire coming through this same grommet to potentiometer terminal 2 (S).
- () Now place the chassis upright and locate the terminal strips near the front of the chassis.
- () Connect the two black wires coming through the 3/8" grommet near the chassis front to lug 5 of the adjacent terminal strip (NS). See Pictorial 4.
- () Connect the blue wire coming through this grommet to lug 2 of this terminal strip (NS).
- () Connect the orange wire coming through the same grommet to lug 1 of this terminal strip (NS).
- () Referring to the wires coming through the 5/16" grommet, connect either blue wire across to lug 2 of the 5-lug terminal strip (S). Shorten the wire if necessary to make a direct connection.
- () Connect the other blue wire from this grommet to lug 4 of this same terminal strip (NS).

- () Connect the green wire to lug 2 of the 4-lug terminal strip immediately adjacent to the 5/16" grommet (S).
- () Select the previously assembled VFO sub-assembly and place a 3/8" lockwasher over the switch bushing. Mount this sub-assembly from the top of the chassis with the two spade lugs through the two holes near the front of the chassis and the switch shaft through the 3/8" hole near front center. Use 6-32 nuts and lockwashers and a 3/8" nut and flat washer to secure the assembly.
- () Connect the red wire from the VFO sub-assembly to lug 4 of the 4-lug terminal strip (S).
- () Connect the orange wire from the VFO sub-assembly to lug 1 of the 5-lug terminal strip (S).
- () Bring the remaining black and blue wires around on the other side of the switch shaft and connect the blue wire to lug 4 of the 5-lug terminal strip (S) and the black wire to lug 5 of the same strip (S). Arrange the wires neatly to clear the switch. Check all work in this section against the step-by-step instructions.
- () Mount three spade bolts on the bottom outside of the VFO shielded cover. Then slip the cover over the VFO assembly with the spade lugs inserted in the three chassis holes. Use 6-32 hardware on the spade bolts and #6 sheet metal screws to fasten the shield to the VFO sub-chassis. Omit the lower sheet metal screw on the side of the enclosure adjacent to the crystal sockets at this time.
- () Place the pilot lamp bracket on the remaining sheet metal screw so that the bulb will be positioned at the chassis center and tighten securely in place.
- () Connect the two black wires coming through the chassis at this point to terminal 1 of the pilot lamp (S). Connect the green wire to terminal 2 of the pilot light (S). Leave the wires long enough that the socket can be removed to change the pilot lamp if necessary. Screw the 115 volt pilot lamp into the socket securely.
- () Select the driver shield and mount a feedthrough insulator in the end hole as shown in Figure 13. Use a solder lug on each end of the insulator, pointing in the direction shown in Pictorials 7 and 8. Cut off the end of the stud protruding past the nuts on each side of the insulator.



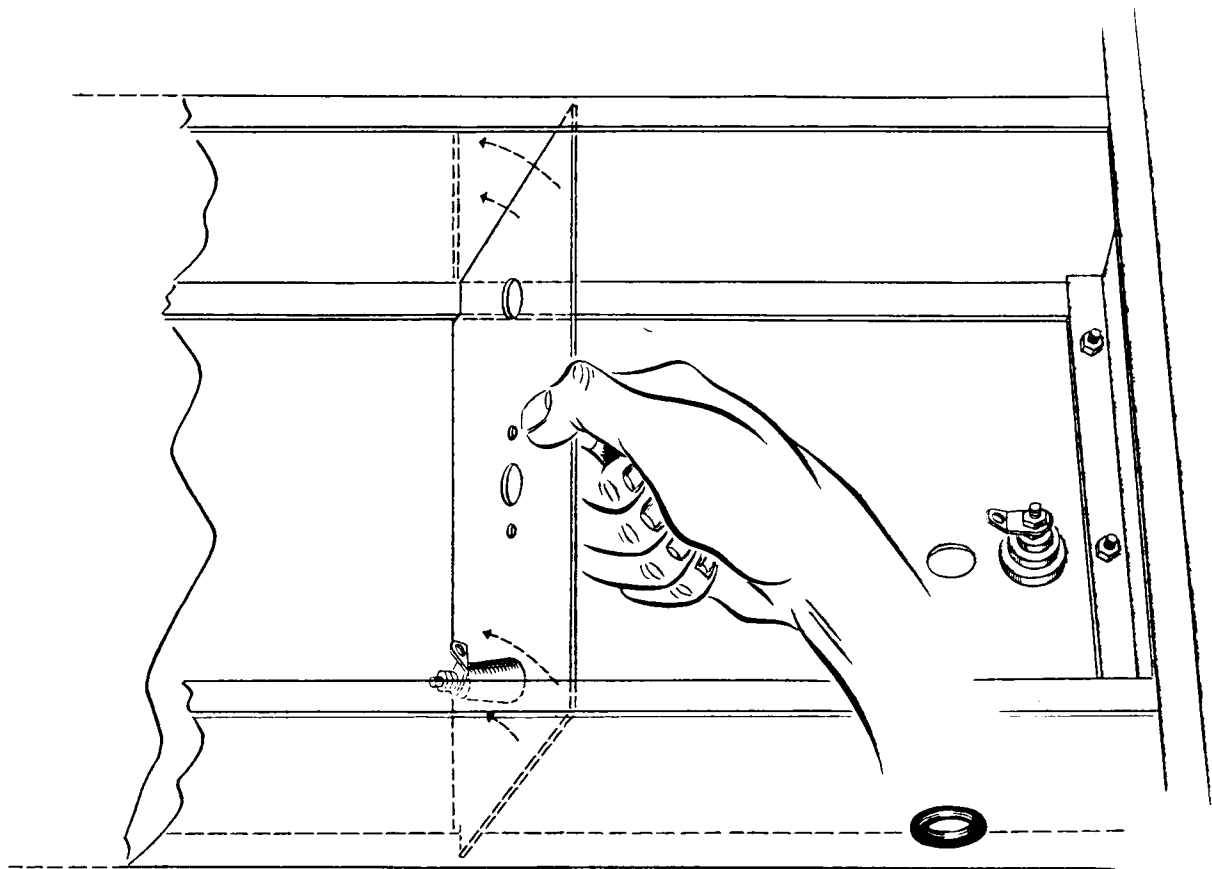
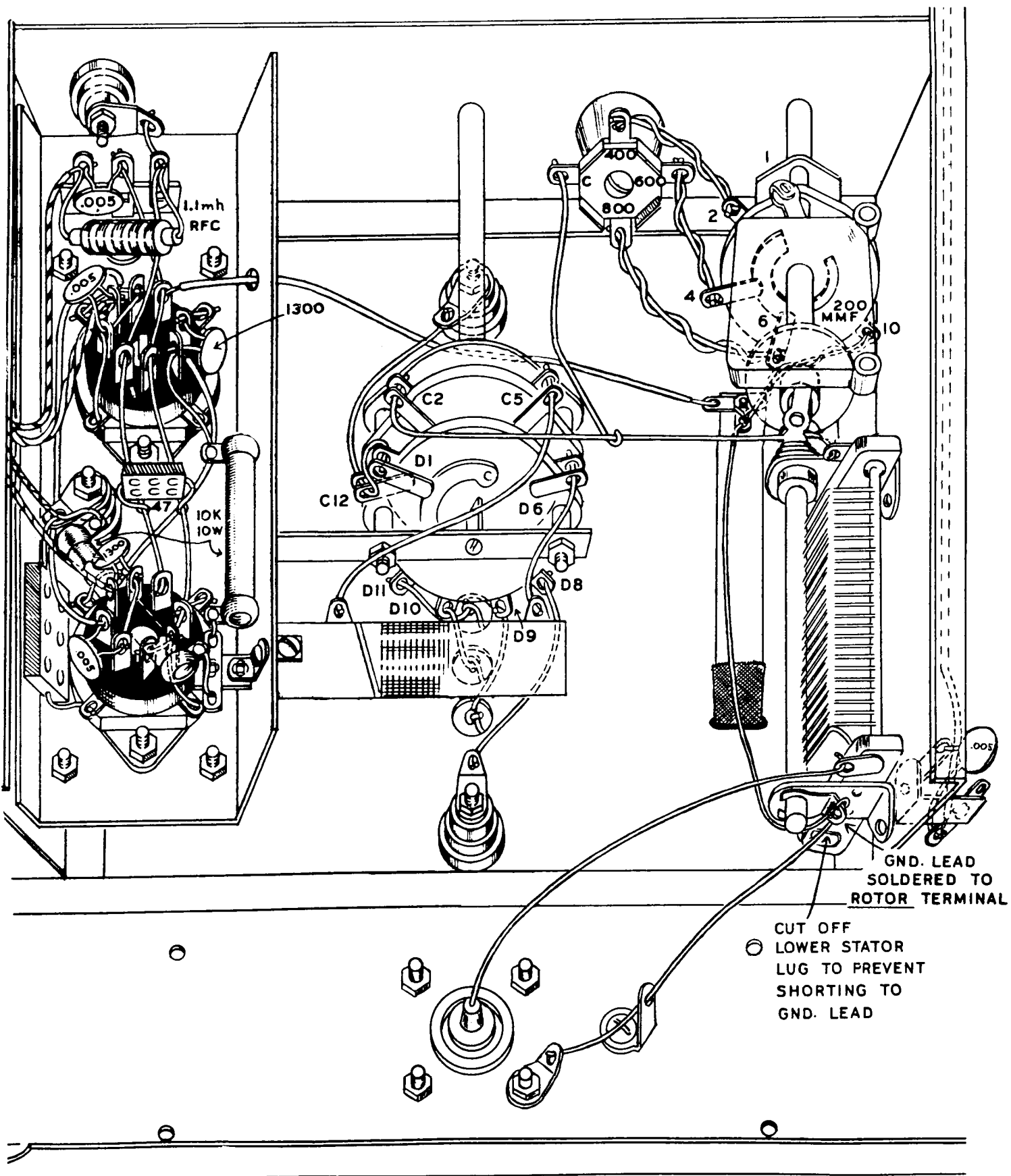

Figure 13

- () Turn the chassis on its back apron again and loosely install this shield across the middle of the RF compartment with 1/4" x 6-32 hardware. Refer to Pictorial 8 on Page 38 for location of the shield and to Figure 13 for the method of installation. Note how the shield must be moved into position in two steps so as to pass the chassis flanges. Leave the nuts loose at this time so the shield can be moved around.
- () Mount the large final amplifier shield plate with spade lugs as shown in Pictorial 9 on Page 46. Note that the spade lugs are on the back side of the shield. Tighten securely.
- () Select the four 6-32 x 1" screws and 3/4" spacers and use these to mount the 6146 sub-chassis. Locate the four 5/32 holes close to the two large chassis holes in the main chassis. Insert two of the 1" screws in the holes closest to the chassis brace. Slip two 3/4" spacers over the screws from the bottom side and then move the 6146 sub-chassis into place. Since the driver shield plate was left loose, it can be moved upward so that the 6146 sub-chassis can be inserted toward center and then moved in under the feedthrough insulator on the driver shield plate. Insert the 1" screws in the holes in the 6146 sub-chassis and use lockwashers and nuts on them. Leave the nuts loose at this time.
- () Now tighten the mounting screws of the driver shield plate securely. Take care not to damage the driver tuning capacitor in doing so.
- () The two remaining 1" screws should be inserted through the holes in the main chassis, slipped through the 3/4" bushings and the holes in the 6146 sub-chassis. Use lockwashers and 6-32 nuts as on the other two screws and tighten all four screws securely.
- () Now check the feedthrough insulator on the 6146 sub-chassis from the main chassis top. The stud bolt of the insulator should project at least 1/4" above the chassis and clear the chassis hole at all points. If not, correct this condition at this time.
- () When the above conditions are fulfilled, mount the small #6 solder lug at the stud end using two 6-32 nuts. Bend the solder lug to make contact with the bottom RF choke terminal and solder.



PICTORIAL 8

- () At point 9 of the cable (within the 6146 compartment) connect the red lead to the solder lug on the feed-through insulator (NS).
- () Connect the orange lead at this point to pin 3 of socket B (S). Refer to Figure 10 for socket identification.
- () Connect the twisted pair of black wires coming through 3/4" grommet D to pin 7 of socket A (S).
- () Connect the violet lead coming through grommet D to lug 1 of the terminal strip (S).
- () Connect a short bare wire from lug 3 of the terminal strip (S) to the adjacent solder lug on the feed-through insulator (S).

- () Using a 5 1/4" length of #14 bare wire, slip a 4" length of sleeving over the wire and pass it through hole AA in the side of the 6146 sub-chassis (see Figure 10). Connect the end of the wire to pin 1 of socket A (S) and connect the other end to the ground lug on the silver strap at the tuning capacitor mounting screw (NS). Run the wire down close against the chassis by bending it at right angles where it comes through hole AA.
- () The bandswitch consists of two main sections. The front section has one wafer and the back section has two wafers. Select the back section and refer to Figure 14 and Pictorial 8 to identify the terminals.
- () Use an icepick to spread the holes in the switch terminals so that large #14 tinned wire can be inserted through them. Note that all terminals are doubled to handle the extra current and therefore each pair should be treated as a single terminal when making connections. The wire should be soldered to both terminals when instructions for soldering are given.
- () Insert a large bare wire through both contacts of terminal 12C and bring the end over to 1D. Arrange the wire to clear the switch post and shape the wire with pliers so as not to put undue strain on the switch terminals. Solder both pair of terminals and leave 1 3/4" of wire extending from terminal 12C. Form the wire as shown in Figure 14.
- () Still using #14 wire, solder the end of a 1" length to terminal 11D. Leave the other end free.
- () Solder the end of a 1 3/4" length of large bare wire to terminal 10D and leave the other end free.

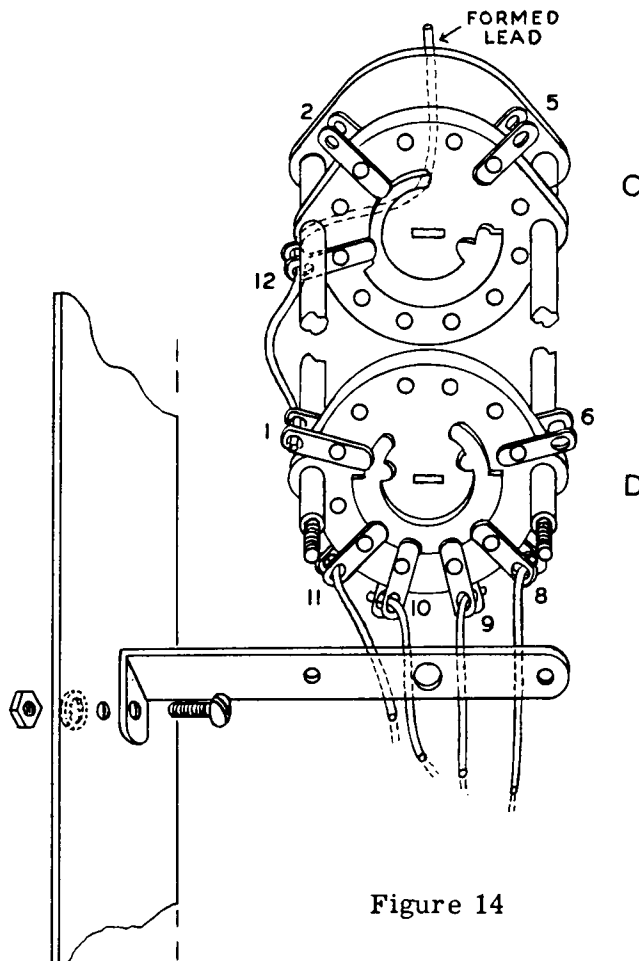

Figure 14

- () Solder the end of a 2 1/4" length of large bare wire to terminal 9D. Leave the other end free.
- () Solder the end of a 3 1/4" length of large bare wire to terminal 8D. Leave the other end free.
- () Use a screwdriver to position the switch rotors as shown in Figure 14. Note the position and shape of the rotor blades. Rotate both switch rotors to the exact position shown so that the back section of the switch will be properly oriented with respect to the front section to be installed later.
- () Move the entire switch into position as shown in Figure 14, taking care to guide the single #14 wire protruding from the front of the switch into the solder lug on the feed-through insulator near the driver shield plate. Use 6-32 hardware to fasten the switch mounting foot to the hole near the center on the side of the 6146 sub-chassis. Do not tighten the mounting screw on the foot at this time.
- () Bend the bottom tank coil tap protruding through the chassis approximately 1/2" to the right, keeping it centered in the chassis hole and connect the heavy wire from terminal 9D to it (NS).
- () Leave the center coil tap straight out from the chassis and connect the wire from terminal 10D to it (NS).
- () Bend the top coil tap approximately 1/2" to the left, keeping it centered in the chassis hole and connect the wire from switch terminal 11D to it (NS). These connections will not be soldered until after the switch mounting foot has been tightened.
- () The long wire from terminal 8D should be run clear of the other taps and connected to the rear feed-through insulator solder lug (NS).
- () Use a pair of pliers to set the VFO switch (the short shaft protruding through the bottom of the chassis) to its center position.
- () Select the VFO switch driven plate (see Figure 16 on Page 41) and insert a 1/4" x 8-32 set screw in the hub. With the hub toward you and the VFO switch in the center position, slip the hub onto the switch shaft and aim the center plate projection directly toward the 3/8" grommet near front center on the chassis. The driven plate should be spaced 1/4" away from the chassis surface. Tighten the set screw by inserting the screwdriver through the 3/8" hole in the right center chassis brace.

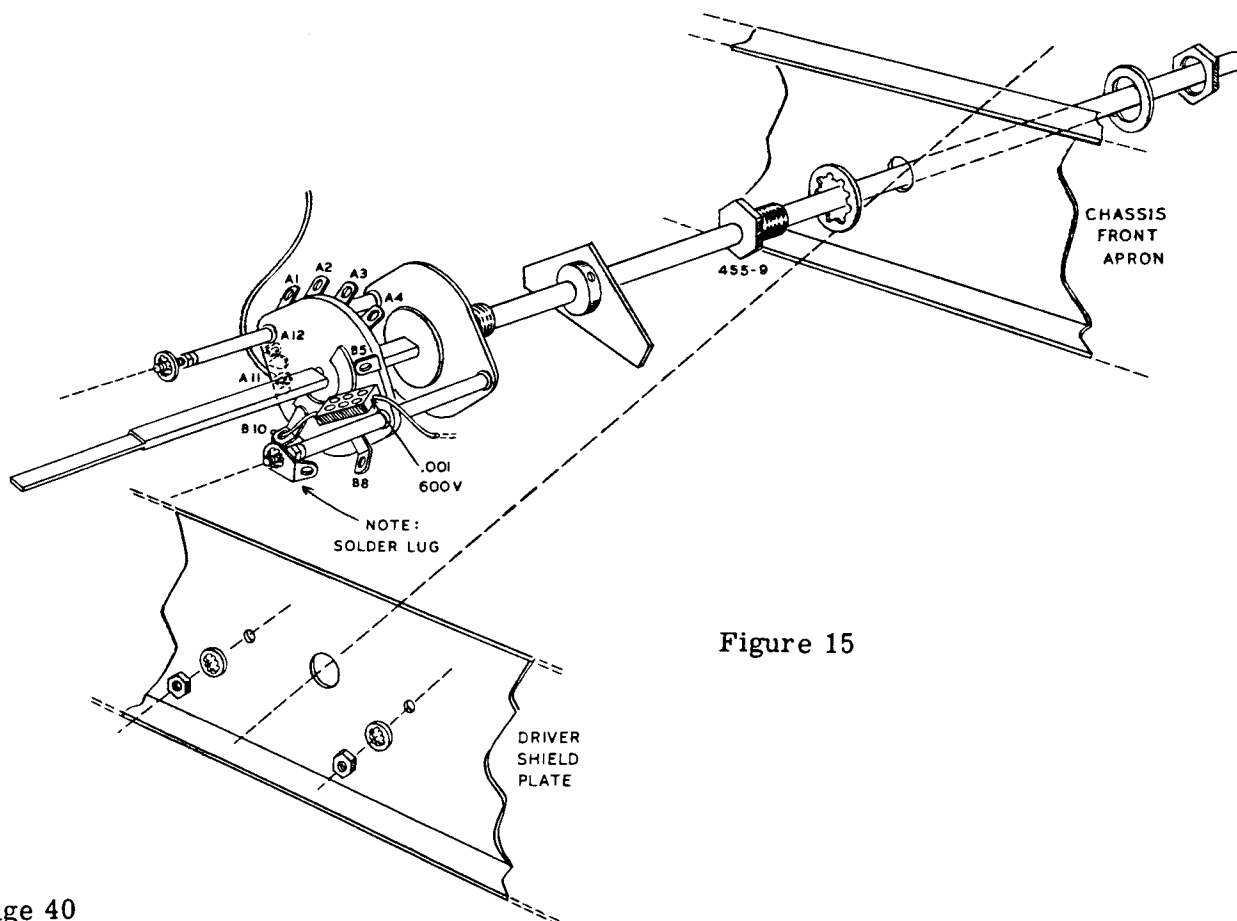

Figure 15

- () Prepare the front section of the main bandswitch for mounting as follows: Rotate the switch shaft all the way clockwise as viewed from the front. Refer to Figure 15 on Page 40 to identify the terminal numbers on the switch. Remove the extra nuts from the switch mounting studs and lay them aside temporarily.
- () Expand terminals A11 and A12 on the switch with an icepick to that they will accomodate heavy bare wire.
- () Connect a heavy bare wire 2 5/8" long to switch terminal A11 (S). Form as shown and leave the other end free.
- () Cut one lead of a .001 μ fd 600 volt mica capacitor to 5/8" and connect to terminal B10 (S). Leave the other end free. Position the capacitor as shown in Figure 15.
- () Slide the hardware shown in Figure 15 onto the switch shaft and leave it loose.
- () Now insert the switch shaft in the front chassis apron hole far enough that the rear shaft will drop into the hole in the driver shield plate. Carefully engage the rear switch rotors as the shaft is slipped down through the sections. The wafer of the front switch section should be oriented as in Figure 15.
- () Use the extra nuts that came with the switch along with the lockwashers, to fasten the studs to the driver shield plate.
- () Now tighten the foot of the bracket holding the rear switch section. If this appears to place tension on the switch shaft, use a fiber washer or #6 lockwasher under the foot. Solder the leads that run from this switch section to the coil taps and the feed-through insulators.
- () Temporarily connect a knob to the main bandswitch. Rotate the switch fully counterclockwise and then one position clockwise. Position the VFO switch fully counterclockwise and be sure the cable clears the switch mechanism.

- () Set the driver plate on the bandswitch shaft as shown in Figure 16. Some experimentation may be required to obtain optimum position for the driver plate. Note that with both switches fully counterclockwise, both VFO and transmitter stages are in the 160 meter position. As the bandswitch is moved to the 80 meter position, it should just clear the center projection of the VFO switch and engage the right hand projection on the VFO plate without moving the VFO switch. As the bandswitch is moved to 40 meters, the VFO switch should move one position. Switch through 40 meters, 20 meters, 15 meters and 10 meters with the bandswitch. The plate should clear the right hand projection and engage the middle projection at the 10 meter position without moving the VFO switch. Switching to 11 meters with the bandswitch should move the VFO switch one more position. When switching from 11 meters back to 160 meters, the device should operate smoothly in the reverse order.

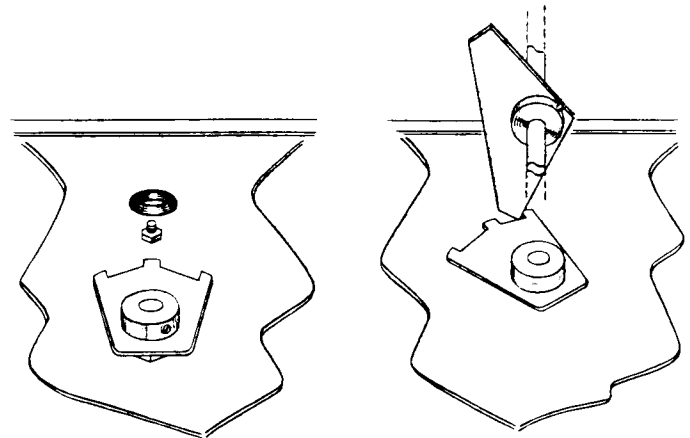

Figure 16

- () Connect the free end of the .001 μ fd 600 volt mica capacitor on the front section of the bandswitch to the ground lug on the switch mounting stud (S). See Pictorial 7.
- () Slip a 2 3/8" length of sleeving over the bare wire coming from terminal 1 of the 40 meter oscillator coil and connect it to terminal B8 of the bandswitch (S).
- () Slip a 2 1/8" length of sleeving over the lead coming from terminal 1 of the 20 meter oscillator coil and connect it to B5 of the bandswitch (S). This completes the oscillator section wiring.
- () Cut a black wire to a length of 4" and strip back at both ends. Pass one end of this wire through the rivet hole at terminal 1 of the low frequency driver coil on top of the chassis.
- () Connect the other end of the wire to terminal A4 (S) of the bandswitch.

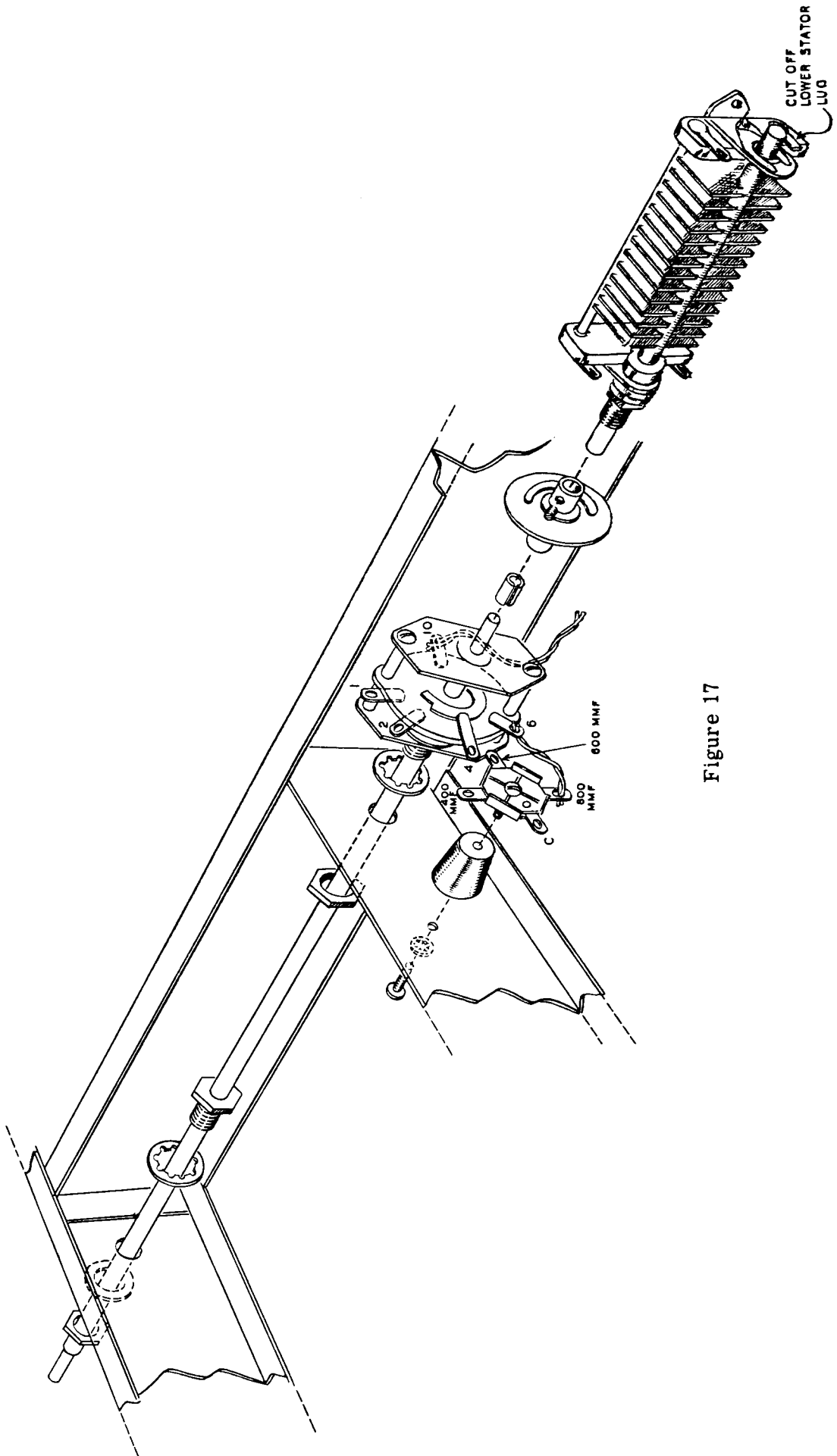

Figure 17

- () Move the capacitor in under the rear switch shaft at a slight angle and maneuver into place so that the switch shaft fits into the top coupler hub and split bushing.
- () Install 1/4" x 6-32 capacitor mounting screws through the side compartment shield using a lockwasher under the front screwhead. On the rear screw, mount a 1-lug terminal strip and solder lug in place of the lockwasher. Position as shown in Pictorial 8. Tighten both securely.
- () Now center the coupler over the two shafts and tighten the set screws in the hubs.
- () Run a piece of #14 wire down through the back rotor terminal of the variable capacitor, through the large ground lug to the small ground lug on the back chassis apron. Solder all three connections and run the other end of the wire to the ground lug at the end of the silver ground strip. Solder all connections at the ground strap also.
- () Cut a 5 1/16" length of #14 bare wire. Grasp the wire 11/16" back from one end and bend to 90°. Grasp the other end of the wire 7/16" back and bend to 90° in the opposite direction from the first bend. The bends should be 3 7/8" apart.
- () Insert the top of this wire at the short end into the front stator terminal of the variable capacitor. Pass the other end through both lugs of terminal C2 of the bandswitch. Refer to Pictorial 8 for position of this wire. Shape the wire around the contour of the switch wafer with at least 1/8" or more clearance. The wire should run horizontally across the RF compartment. Solder both ends of the wire.
- () Select the large .0002 μ fd 600 volt mica capacitor and connect it between loading switch terminal 1 and the heavy wire just connected across the RF compartment. (See Pictorial 8 for position of the capacitor.) Bend about 1/8" of the capacitor tabs to make a secure soldered lap joint at the switch terminal and the #14 wire.
- () Run another heavy #14 bare wire from the same horizontal wire over to the remaining common terminal of the 3-section octagonal capacitor. Solder both ends of the wire.
- () Using #14 bare wire, bend 1/4" of wire at one end to 90° and insert the end upward through the rear variable capacitor stator terminal (S). Run the wire in a curving arc over to the center terminal of the coaxial connector on the back chassis apron. Bend the wire down at this point so it will fit into the coaxial connector terminal. Solder here also.
- () Select the 160 meter section of the final tank coil (wound on a 7/8" ceramic coil form) and mount it on the side apron of the 6146 sub-chassis as shown in Pictorial 8. Use a 6-32 x 1/4" screw and nut and mount a 1-lug terminal strip on the other side of the sub-chassis apron (see Pictorial 8).
- () Run a #14 bare wire from both tabs on terminal C5 of the bandswitch (S) over to the coil terminal closest to the mounting screw (S).
- () Pass a piece of #14 wire through the other coil terminal and on over to D6 on the bandswitch. Solder the wire at both ends and trim off the wire at the coil terminal.
- () Select the two 10,000 Ω 10 watt resistors and connect one from the solder lug on the feed-through insulator (S) to the back of the 1-lug terminal strip in the 6146 sub-chassis (S). Use full lead length on this resistor.
- () Connect the other 10,000 Ω resistor from the same terminal strip to pin 3 of socket A (S). Use the full lead length on the socket end and cut the other end to an appropriate length to let the resistor run parallel to the chassis.

This completes the wiring of the RF compartment.

FINAL ASSEMBLY AND WIRING

- () Connect a line filter choke from the 1-lug terminal strip on the chassis center brace (NS) to pin 1 of the rear apron octal socket (S). (See Pictorial 10, Page 49.)
- () Connect a .005 μ fd disc ceramic capacitor from the single lug (NS) to the adjacent ground solder lug (S).
- () Connect a blue wire from the terminal strip lug (S) to terminal 1 of the PLATE switch M (S). Run the wire against the chassis center brace.
- () Locate the meter switch and identify the switch terminal numbers by referring to Figure 18. Use #20 bare wire to tie switch terminals 4, 9 and 12 together and leave 5" of wire extending from terminal 12. Solder these connections.
- () The switch may now be temporarily mounted so that its wiring can be completed. For convenience, a special switch bracket has been included to facilitate switch wiring before the panel is mounted. The bracket is shown in Figure 18. Temporarily mount one end on the audio gain control and mount the switch through the hole in the other end.
- () Cut and strip each of the wires to appropriate length so that the cable will lie down against the chassis and come straight up to the meter switch. Connections should be made as follows:
 - () Two violet leads on switch terminal 11 (S).
 - () Gray lead on switch terminal 10 (S).
 - () White lead on switch terminal 8 (S).
 - () Yellow lead on switch terminal 6 (S).
 - () Brown lead on switch terminal 5 (S).
 - () Red lead on switch terminal 3 (S).
 - () Blue lead on switch terminal 2(S).
- () Connect a 3" red wire to terminal 1 (S) and leave the other end free.
- () Connect a 3 1/2" black lead to terminal 7 (S) and leave the other end free.
- () Select the front panel and prepare for mounting by first installing the meter in its place. Mounting hardware is supplied with the meter. Remove the shield and pilot lamp from the meter and then mount it with the meter mounting studs through the appropriate panel holes. In placing nuts over the studs, use a ground lug under the lower left mounting stud as viewed from the rear (see Pictorial 9 on Page 46.) Tighten all four nuts securely.
- () Now slip the metal shield over the back of the meter. Use a solder lug on the screw that fastens the shield to the plastic meter case and tighten securely.
- () Use an ohmmeter or continuity tester to determine which pilot lamp lead connects to center contact of the pilot lamp socket. When this has been done, bend a sharp kink in this wire to identify it. Make no connection to it at this time. Cut the remaining pilot lamp wire to 3" and connect to the ground lug on the meter shield (NS).
- () Connect one end of two .005 μ fd disc ceramic capacitors to this same ground lug (NS). Connect the other ends of the capacitors to each meter terminal using the solder lugs provided with the meter (NS).
- () Now mount the Heathkit emblem on the other end of the panel just over the word TRANSMITTER. Push the plastic pins into the holes in the panel and apply a hot soldering iron to rivet over the pins on the back while holding the emblem tightly in place against the panel.
- () Select the two 1/4" I. D. 3/8 x 32 bushings and slip a 3/8" lockwasher on each one. Install one of these bushings in the DRIVER shaft hole on the panel and one in the AMPLIFIER shaft hole. Use a 3/8" flat washer and nut to secure each bushing. Tighten the driver and amplifier bushings securely.

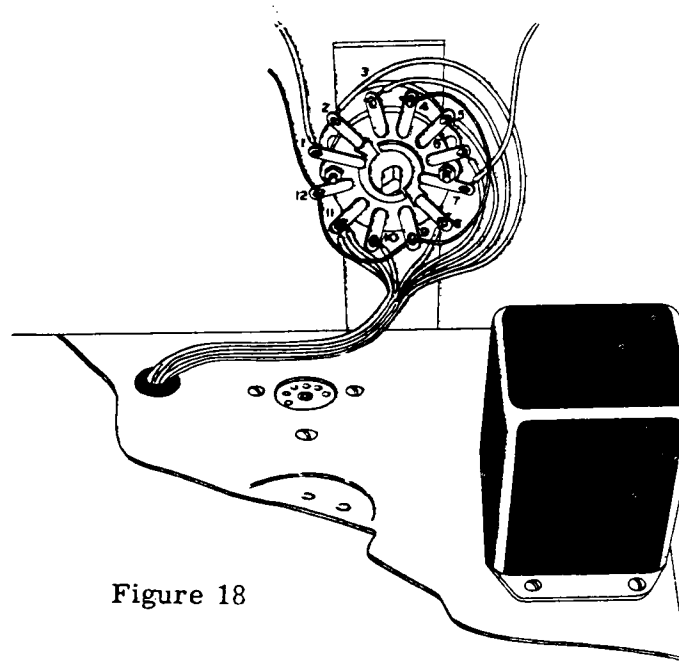
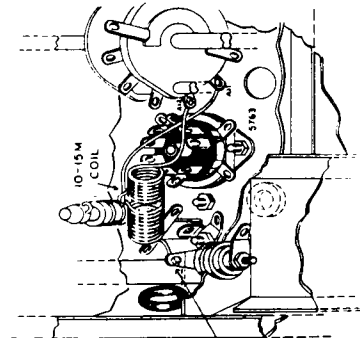
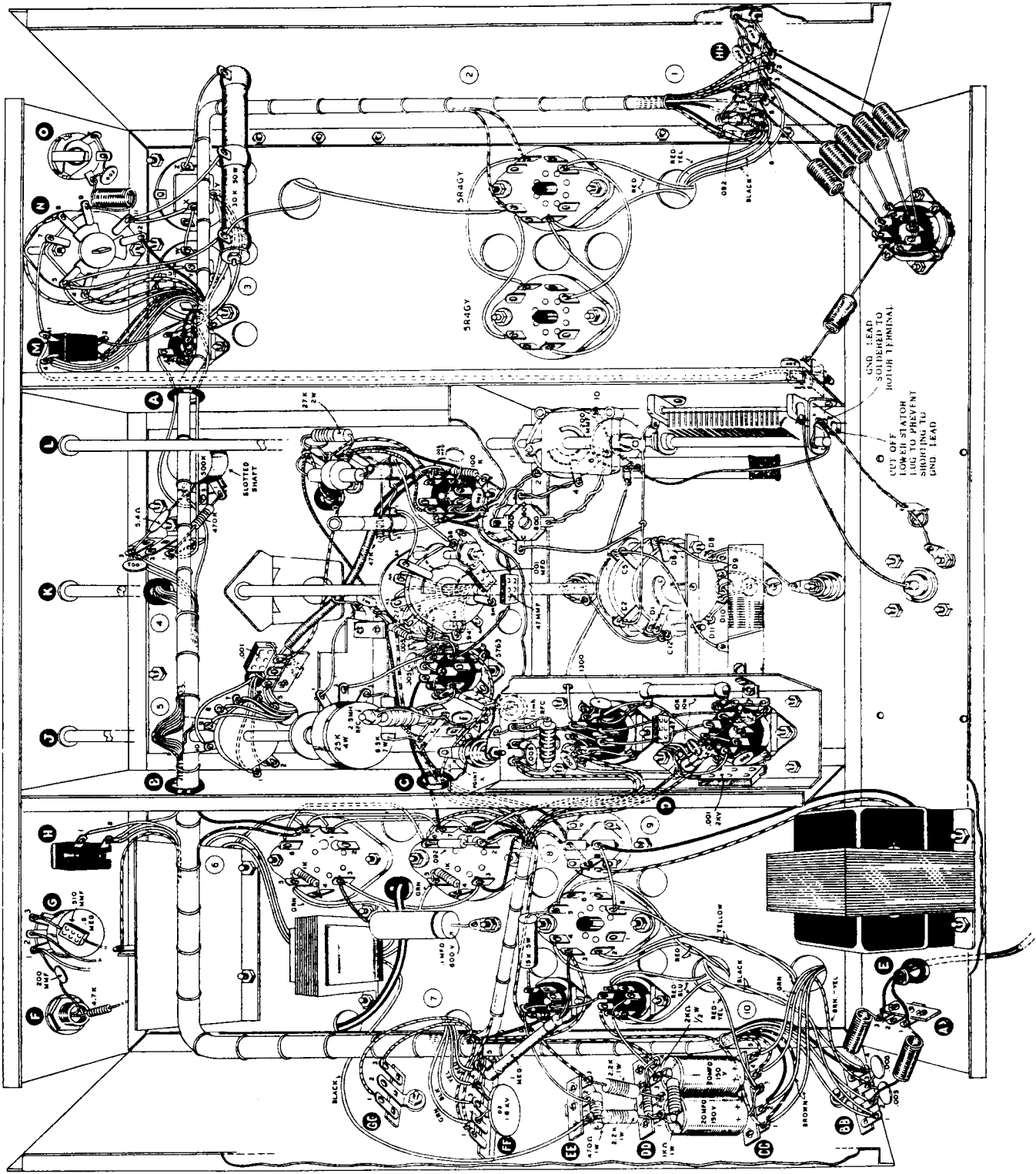

Figure 18

- () Select the 1/4" I. D. bushing with the thin round shoulder and mount in FREQUENCY hole in the panel. Omit the lockwasher and secure with a flat washer and nut. Do not tighten yet.
- () Select the pilot light jewel and spread the tabs very slightly so it will snap into the hole just above the word BAND on the panel. The panel is now prepared for mounting to the chassis.
- () Prepare the main chassis to receive the panel by removing the nuts and flat washers from controls on the front chassis apron. Also remove the temporary bracket that was used to support the meter switch.
- () To mount the panel, slip the friction dial drive pulley into the FREQUENCY bushing from the back. Hold the dial drive pulley shaft from the front and slide the bushing upward in its elongated hole. As the panel is placed against the chassis apron, the dial drive must be positioned over the inside edge of the plastic dial scale while the various controls are guided into the holes in the panel. The pulley must engage the edge of the plastic dial scale in order to drive the scale as the pulley turns.
- () With the panel aligned carefully over the controls, place 3/8" flat washers and nuts on the control and switch bushings and draw up finger tight.
- () Install the mike connector on the front panel using the nut supplied on the back bushing. Tighten securely, using an end wrench if necessary to reach up into the close quarters between the chassis apron and the audio shield plate. Now tighten the rest of the controls and switches along the bottom row on the panel. Position the audio gain control so that its terminals point toward the open bottom of the chassis before tightening.
- () Place a 1" length of sleeving over the free end of the 4700 Ω resistor and then feed this lead up through the center hole in the mike connector (NS).
- () Place a 3/4" length of sleeving on one lead of a 220 $\mu\mu\text{f}$ disc ceramic capacitor and feed this lead up through the same hole in the mike connector until the sleeving is flush with the underside of the hole. Now solder both wires at this point and clip off the excess wire protruding from the connector.
- () Connect the remaining lead of the 220 $\mu\mu\text{f}$ capacitor to the left hand potentiometer terminal as viewed from the chassis bottom (NS).
- () Connect the end of the bare ground lead already in the circuit to this same potentiometer terminal (S).
- () Connect the green wire coming from the 12AX7 tube socket to the center terminal of the potentiometer (S).
- () Slide a 1" length of sleeving over the remaining free lead of the 510 $\mu\mu\text{f}$ mica capacitor and connect the lead to the right hand terminal of the potentiometer (S).
- () Insert the line cord through the grommet in the rear chassis apron and tie a knot about 1" from the end of the cord. Connect one lead of the cord to lug 1 of strip AA and the other lead to lug 3 of strip AA. Solder both connections.
- () Install the fuse plug on the other end of the line cord as follows. Open the plug to expose the screw terminals. Tie a knot approximately 1" back from the end of the cord and separate the leads back to the knot. Strip the end of the leads back 1/2" and tin the bare strands lightly. Position the knot in the "bell" of the plug, run the leads along the separate channels provided and connect the wires to the screw terminals with a hook in the same direction as the screw rotation. Reassemble the plug and install two type 3AG fuses rated not higher than 8 amperes.
- () Mount the meter switch in the appropriate hole just below the meter, using a 3/8" flat washer and nut on the shaft.
- () To connect the meter into the circuit, connect the free end of the 3 1/2" black wire to the right hand meter terminal as viewed from the rear (S).
- () Connect the bare wire from the switch through the solder lug on the lower left meter mounting stud, along the shield and to the ground lug on the meter shield itself. Solder both connections.
- () Connect the 3" red wire to the remaining (plus) meter terminal (S).
- () The remaining lead from the meter pilot light should be connected to the 1-lug terminal strip on top of the VFO enclosure (S).

- () Select the two porcelain plate caps and solder them to the ends of the brown and blue leads coming up out of the top of the chassis to the 1625 tubes.
- () Insert the 6146 final amplifier tubes in their sockets and place the aluminum heat dissipating plate caps on the top of the tubes. Tighten the set screws only enough to secure a snug fit.
- () Leave the leads of the parasitic chokes full length, form a hook in the end and connect to the heat dissipating plate caps.
- () Locate the shafts of the driver tuning capacitor and final amplifier tuning capacitor on top of the chassis. Install a flexible coupling on each shaft and tighten securely.
- () Now select the 6 11/16" long x 1/4" shaft rod and insert it through the driver bushing and into the coupler of the capacitor. Leave 3/8" of shaft protruding beyond the front panel bushing and then tighten the set screw in the coupler hub.
- () Select the 9" long x 1/4" shaft and insert through the amplifier bushing on the front panel and into the coupler hub on the capacitor. Leave 3/8" of shaft protruding out beyond the panel bushings and tighten the coupler hub set screw.
- () Move the VFO frequency control bushing downward in its slot to firmly engage the dial drive without binding. Tighten the 3/8" nut on the bushing when it has been set properly. If the entire bushing turns when attempting to tighten it, hold the bushing from the back with a thin bladed screwdriver or a table knife while tightening it.
- () Install the large diameter knob without a pointer on the VFO frequency shaft and tighten securely.
- () Install the large diameter knob with a pointer on the main bandswitch shaft. Set the switch in the 20 meter position (with the flat downward) and set the pointer on the knob to the 20 meter mark on the panel. Tighten securely.
- () Move the final amplifier tuning capacitor to full mesh and install a large knob on this shaft **with the white pointer at 100 on the panel scale.**
- () Move the driver tuning capacitor to full mesh and install a large knob on the shaft with the white pointer at 100.
- () Move the meter switch to full clockwise position and install a small knob on the shaft with the white line pointing to MOD.
- () Move the audio gain control fully counterclockwise and install a small knob with the white line to 0 on the panel.
- () Move the CW-PHONE switch fully counterclockwise and install a small knob on the shaft with the white line pointing to CW.
- () Set the outside sleeve of the XTAL-VFO switch fully counterclockwise and install one of the open topped knobs with the white line pointing to X1.
- () On the small shaft of this control, install one of the miniature red knobs. The small shaft should be fully counterclockwise and the marker on the red knob should be approximately the same as the white line on the audio gain control when it is in the full counterclockwise position. Use 6-32 x 1/8" set screws on the red knobs.
- () Set the outside sleeve of the loading switch fully counterclockwise and install an open topped knob with the white line pointing to 0.
- () Set the variable loading capacitor to full mesh and install the small red knob with the marker pointing to the #2 on the panel. This control will then increase the loading when moved from 2 to 8 on the panel scale.

THIS COMPLETES THE ASSEMBLY AND WIRING OF THE HEATHKIT MODEL DX-100 TRANSMITTER.



PICTORIAL 10

TUNING INSTRUCTIONS

NOTE: See Figure 19 for a description and the location of all operational controls on the transmitter before beginning the tuning procedure. A knowledge of each control function will assist in accomplishing the tuning without difficulty.

METER SWITCH POS.	MEASURES	RANGE OF READING
DRIVER	DRIVER PLATE CURRENT	0-50 MA
GRID	FINAL AMPLIFIER GRID CURRENT	0-10 MA
PLATE	FINAL AMPLIFIER PLATE CURRENT	0-500 MA
VOLTS	FINAL AMPLIFIER PLATE VOLTAGE	0-1000 V
MOD.	MODULATOR PLATE CURRENT	0-500 MA

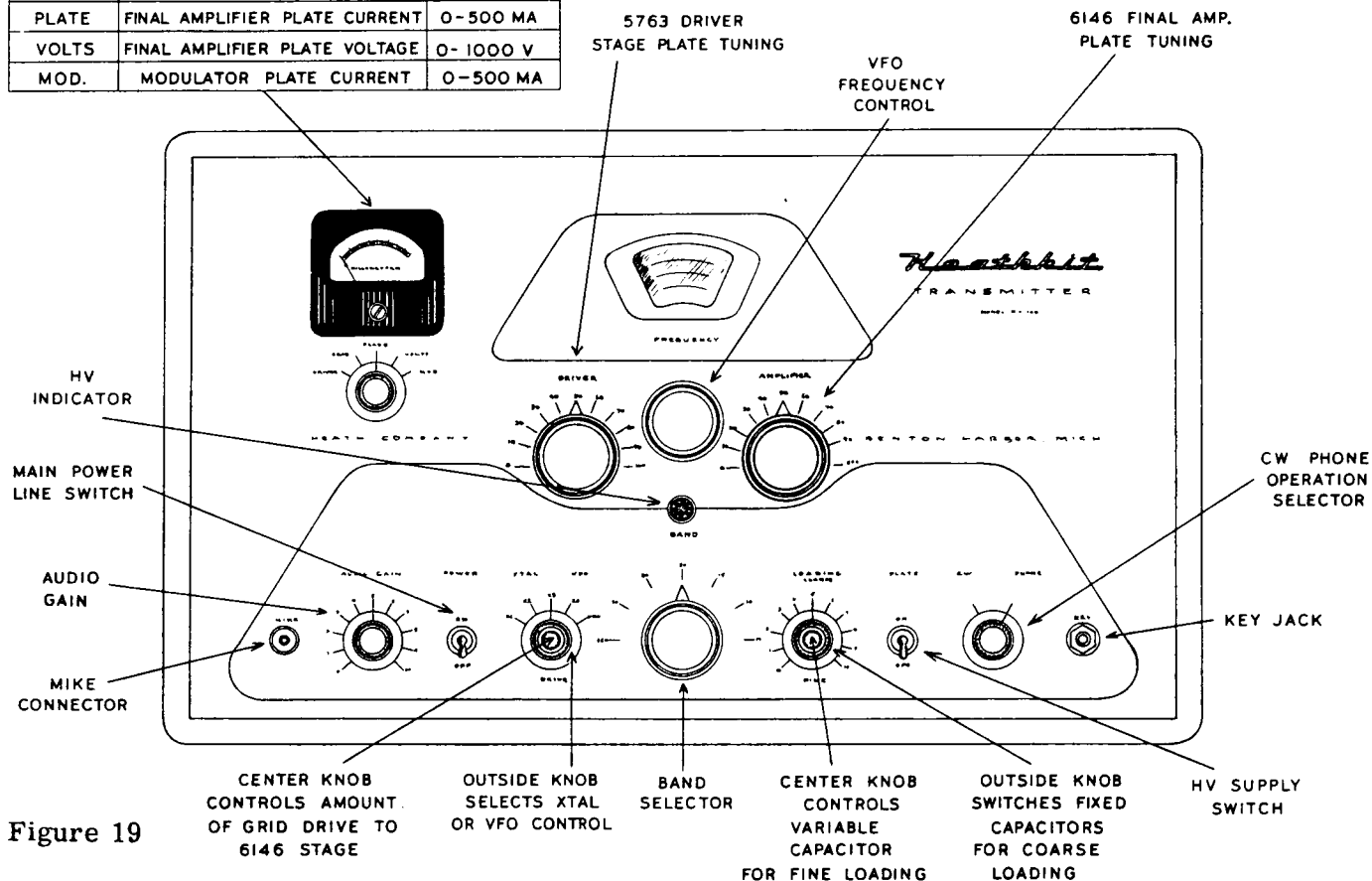

Figure 19

- () Insert all tubes in the proper sockets. Refer back to Pictorial 9 on Page 46 for identification of sockets. Install VFO pilot lamp in its socket.
- () Plug a crystal into the X1 crystal socket (the one closest to the front panel). Select a crystal that will fall within one of the amateur bands, preferably a frequency lower than 40 meters.
- () Connect a 100 watt light bulb to the coaxial connector on the back chassis apron to act as a dummy antenna. This may best be done with the bulb inserted in a porcelain socket. One lead from the bulb should connect to the center portion of the connector and the other should connect to the chassis. A banana plug and alligator clip are convenient for the connections or a short length of coaxial cable may be fitted with a connector at one end and soldered to the light bulb at the other.
- () Before applying power, set the control knobs and switches as follows:

AUDIO GAIN - counterclockwise.
 POWER - off.
 XTAL-VFO - X1.
 DRIVE - counterclockwise.
 BAND - set bandswitch to proper band for crystal frequency used.
 LOADING - set coarse control fully counterclockwise and fine control so indicator points to position 2.

PLATE - off.
 CW-PHONE - CW position.
 METER - grid.
 DRIVER - 50.
 FREQUENCY - no special setting at this time.
 AMPLIFIER - 50.
 CLAMP - fully counterclockwise. (See NOTE.)

NOTE: This is the screwdriver adjustment on the top side of the chassis immediately behind the panel and adjacent to the VFO enclosure and the 6AQ5 tube. (See Pictorial 9.)

CAUTION: BEFORE APPLYING POWER TO THE TRANSMITTER, IT SHOULD BE NOTED THAT LETHAL VOLTAGES ARE PRESENT BOTH ABOVE AND BELOW THE CHASSIS. CARE SHOULD BE EXERCISED NOT TO TOUCH ANY HIGH VOLTAGE POINTS WITH YOUR HANDS. WELL INSULATED TOOLS SHOULD BE USED FOR BEHIND THE PANEL ADJUSTMENTS.

NOTE: At this point, the scale on the meter should be studied carefully to determine just how the meter reads for the various positions of the meter switch. First note that the meter has two scales; one from 0 to 50 and one from 0 to 10. The scales should be interpreted as follows:

METER SWITCH POSITION	MEASURES	RANGE OF READING
Driver	Driver plate current	0-50 ma
Grid	Final amplifier grid current	0-10 ma
Plate	Final amplifier plate current	0-500 ma
Volts	Final amplifier plate voltage	0-1000 volts
MOD.	Modulator plate current	0-500 ma

- () Insert fuses and plug transmitter into a 115 volt AC outlet.
- () Turn the power switch to ON and check to be sure that all the tubes light up. Switch the power off and recheck your wiring if any overheating is observed.
- () If nothing unusual is observed under these conditions, advance the driver control (small red knob centered in XTAL-VFO switch) slightly. Then adjust the DRIVER tuning control for a peak reading. CAUTION: Do not hold the reading above 6 ma for more than an instant. See if at least 6 ma is available through adjustment of the DRIVE control with the DRIVER tuning peaked. Leave grid drive set to 5 ma. Note position of grid DRIVE control knob with 5 ma on the meter so you can return to this setting later. This indicates proper functioning of crystal oscillator and driver stages.
- () Move the XTAL-VFO switch to VFO and peak the VFO FREQUENCY knob until a maximum reading is obtained on the meter. Increase or decrease the grid DRIVE to maintain the 5 ma reading. The VFO frequency dial indication is not significant at this time. VFO calibration will be accomplished later. If at least 6 ma of drive can be obtained, it indicates that the VFO is working also.
- () To test the final amplifier, return the grid DRIVE control to full counterclockwise position, reducing the drive to zero. Move the meter switch to PLATE and the PLATE switch to ON. Turn this switch off immediately in case of any arc, apparent overload or an excessive meter reading (over 300 milliamperes). Normally the meter should not read or should read only slightly up-scale.
- () Move the XTAL-VFO switch to one of the unused crystal positions and adjust the clamp control behind the panel until the meter reading just returns to zero. Then return the XTAL-VFO switch to the VFO position.
- () With the meter still in the PLATE position, adjust the grid DRIVE control with one hand and AMPLIFIER tuning with the other. Advance the drive slowly while simultaneously tuning the amplifier for minimum on the meter, until the grid DRIVE control knob is positioned as it was previously for 5 ma drive level. CAUTION: Do not let the amplifier plate current exceed 300 ma under any circumstances. With the plate current dipped to minimum by the amplifier tuning, return the meter switch to GRID and set the grid drive to 5 ma. Switch back to PLATE and dip the AMPLIFIER tuning again. The final plate current should now read in the lower portion of the meter scale.

NOTE: On some bands it is possible to obtain two dips with the AMPLIFIER tuning. To eliminate the possibility of doubling in the amplifier, always select the dip at the highest reading on the AMPLIFIER tuning. (Capacitor plates near full mesh.)

- () Rotate the COARSE LOADING control a step at a time, dipping the amplifier after each step. The meter reading should increase with each step of load, as should the light bulb brilliance. When final reading is approximately 200 milliamperes, adjust the FINE LOADING control (still maintaining a dip with AMPLIFIER tuning control) for normal operating load of about 250 ma on the meter. Recheck grid current to be sure it still reads 5 ma. If reading has dropped, increase the grid DRIVE control to restore 5 ma reading. Now return the meter switch to the PLATE position.
- () Phone operation may be tested as follows: With all other controls set the same, turn the PLATE switch to OFF and move the CW-PHONE switch to PHONE. Connect a high impedance microphone to the MIKE input connector. Move the PLATE switch ON. The plate current reading should be slightly lower than for CW (240 ma). Move the meter switch to the MOD. position and speak into the microphone while slowly advancing the audio GAIN control. The control should be set so that the audio peaks hit about 125 ma. Without modulation, the reading will be around 50 ma. The light bulb used for a dummy load should peak upward in brilliance with peaks in audio modulation.

CALIBRATION

If the kit constructor has access to an LM or BC frequency standard, they are excellent for calibration. The other alternative is to accumulate as many crystals in the bands concerned as possible. The crystals preferably should be near the edge of the bands. The crystals may be inserted in the crystal sockets of the transmitter and compared to the VFO frequency by means of a nearby receiver having a BFO. If the frequency meter is used the frequency meter and VFO signals can beat against each other in the receiver. Before beginning calibration, allow VFO, frequency meter and receiver to warm up for one-half hour or more. If a BC-221 frequency meter or equivalent is used (do not use ordinary radio service generators) it should be set to 1750 kc. If the crystal oscillator is used, have frequency as near as possible to 1750 or 3500 kc.

During the alignment procedure, the DRIVE control should be fully counterclockwise, the CW-PHONE switch should be on CW and the PLATE switch should be OFF. NOTE: If a frequency meter is used for calibration, the frequency meter signal and the VFO signal should be zero beat against each other in a receiver with the BFO off. When using crystals for calibration, set the receiver to the crystal frequency with the BFO on and zero beat the BFO in the receiver. Align the VFO for zero beat without changing the receiver tuning and the VFO frequency will be the same as the crystal frequency. Aside from this difference, the following procedure may be used for either method of calibration. Refer to Figure 20 for location and identification of the various calibrating adjustments.

NOTE: It should be noted that the trimmer capacitors (A, C and E in Figure 20) are used to set a definite frequency point on the dial, while the coil slugs (B and D in Figure 20) determine the overall frequency range covered by the dial. The capacitors are set to a particular frequency near the low end of the band and the slugs are adjusted so that the high frequency end of the band coincides with the dial reading. These two adjustments interact with each other and therefore should be adjusted alternately until optimum overall calibration is obtained.

Set the VFO to 1750 kc if a frequency meter is used or to the crystal frequency used near the low end of the band. The main bandswitch may be left in the 160 meter position for either 160 meter or 80 meter crystals.

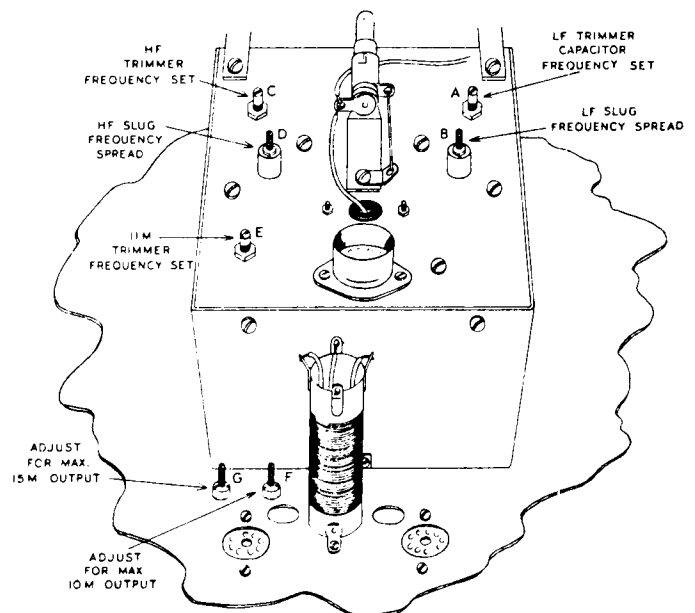

Figure 20

Adjust trimmer A for zero beat in the receiver. Note that the zero beat will be against the frequency meter if available or against the receiver BFO as previously set to zero beat against the crystal oscillator. Now use a crystal near the high end of the band or move the frequency meter up to a frequency of approximately 2000 kc. Reset the receiver as in the previous step. Tune the VFO to the high end of the band and note the reading on the calibrated dial scale. If the dial calibration exceeds the frequency used, adjust slug B clockwise. If the dial reading is less than the frequency used, adjust slug B in a counterclockwise direction. Then go back to the low frequency end and readjust trimmer A. Repeat the process until calibration is achieved at both ends of the band.

Repeat the procedure outlined above for the higher bands. Move the bandswitch to the 40 meter position and leave all other controls the same. The receiver and signal sources (crystal or frequency meter) must operate between 7 and 7.425 mc. Trimmer C and slug D in Figure 20 operate the same on this band as trimmer A and slug B on the lower band.

For 11 meter calibration, set the band selector to the 11 meter position and use a signal source (either a crystal or frequency meter) between 6740 and 6807.5 kc. Trimmer E only is used to zero beat the calibrating frequency against the dial reading at 27 mc on the VFO dial. This completes the VFO calibration procedure.

ADJUSTMENT OF BUFFER COILS

Set the bandswitch to the 10 meter position and the VFO dial to 28.8 mc. Advance the DRIVE control until a grid current reading can be obtained on the meter when tuning the driver stage for a peak. Adjust slug F (as shown in Figure 20) for a maximum reading on the meter.

Now switch the band selector to 15 meters and set the dial to 21.3 mc. Peak the driver stage again and adjust slug G for a maximum reading on the meter.

IN CASE OF DIFFICULTY

Mistakes in wiring are the most common cause of difficulty. Consequently, the first step is to recheck all wiring against the pictorials and schematic diagrams. Often having a friend check the wiring will locate an error consistently overlooked.

Also, with miniature sockets there is a possibility of shorts between adjacent socket terminals due to the close spacing. This should be checked and if any doubt exists, the terminals should be pried apart until obvious spacing can be seen between them.

Sometimes apparently good solder connections will have an insulating coating of rosin between the wire, the terminal and the solder. This is often the case when insufficient heat was applied in soldering. An ohmmeter check of any questionable connections will test for this condition. Naturally, all voltages should be "off" for such tests.

The transmitter is fused at the line cord plug. A type 3AG fuse is required on each side of the line plug with a rating not in excess of 8 amperes. Should it be found that fuses consistently blow whenever the equipment is plugged in and the POWER switch is turned ON, resistance tests of the low voltage power supply should be made in accordance with the following chart. If a fuse blows whenever the PLATE switch is moved to the ON position, the high voltage power supply should be checked with an ohmmeter as outlined in the chart on Page 54. In either case, it is important that the power switches be OFF and the line plug removed when the resistance measurements are made. As additional insurance against shock, a screwdriver blade should be used to short from the chassis to the hot end of the bleeder resistor and from the chassis to each of the filter condensers so that they will be thoroughly discharged.

Be sure to reread the circuit description on Page 3 so that "cause and effect" reasoning may be employed as the search for trouble progresses. If some difficulty still persists after the steps outlined have been completed, attempt to localize the trouble to a particular stage in the transmitter circuit. Use the tuning procedure as a basis for localization and refer to the block diagram and schematic to visualize circuit relationships. The panel meter and station receiver are extremely valuable tools to use in locating trouble.

RESISTANCE MEASUREMENTS

TEST CIRCUIT	TEST POINT	OHMS TO GROUND
Low Voltage Supply	Low Voltage Filter	32 K Ω
High Voltage Supply	High Voltage Filter	30 K Ω
Bias Supply	Pin 2 or 7 6AL5 tube	5.6 K Ω
Final Grid Circuit	6146 Grid Bus	6.7 K Ω
Oscillator Screen	Pin 8 12BY7 tube	60 K Ω
Modulator Screen	Pin 3 1625 tubes	15 K Ω
Final Amplifier Screen	Pin 3 6146 tubes	52 K Ω

If a grid current reading cannot be obtained at the panel meter, the receiver may be used to check VFO and/or crystal oscillator operation. Connect a short piece of insulated wire to the receiver antenna terminal and bring the wire near the VFO or crystal oscillator tubes. Tune the receiver to determine if a signal is being generated by the respective oscillator circuits. If no signal is present, check the tubes and notice the OA2 voltage regulator tube to see if it has a blue glow. If the OA2 shows blue, B+ is present. If this tube is dark, check the B supply. If only one of the oscillator circuits works, check the XTAL-VFO switch wiring.

If it should be determined that both oscillator stages are functioning properly, but still no grid drive can be obtained on the meter, turn the meter switch to the DRIVER position and advance the DRIVE control fully clockwise. The meter should read upscale, indicating plate current in the driver stage. No reading shows a defective driver tube, lack of DC operating potentials on the driver stage, an open cathode, screen or plate circuit, lack of coupling between oscillator and driver stages or detuned oscillator coils.

If, on the other hand, driver plate current can be obtained on the meter, try adjusting the DRIVER control for a dip in plate current. No dip could be caused by improperly connected driver tank coils or a poor connection to the driver tuning capacitor.

Should it be found that a dip can be obtained in driver plate current when tuning the driver, but still no grid current is available, the 6146 grid circuit may be open at some point. Note that the grid circuit includes a 1.1 mh RF choke, a shunt resistor for the meter, a 2.2 K Ω grid resistor and bias supply bleeder resistors. If an ohmmeter is available, measure the overall grid circuit continuity with the power turned off. The reading should be in the vicinity of 6.7 K Ω . If such a test shows an open, check each grid circuit component separately to find the defective component or connection.

Assuming that grid current is available in the correct quantity, difficulty in the 6146 stage may manifest itself in the form of an excessive plate current reading, insufficient plate current or inability to obtain resonance when tuning the final amplifier.

Excessive plate current could indicate a shorted RF bypass condenser in the final stage, lack of grid bias, detuned final tank circuit or miss-set loading control.

Insufficient plate current would suggest low plate voltage and this can easily be checked with the panel meter in the VOLTS position. If plate voltage is present but plate current is still low, the clamp control may be miss-set (see tuning procedure for proper adjustment) or the screen circuit may be shorted or open.

Failure to reach resonance when tuning the final tank circuit could indicate an incorrectly wired bandswitch or loading switch, a shorted loading capacitor or any other short or ground in the final pi-network circuit. Also, do not overlook the possibility that the frequency controls in previous stages may be incorrectly adjusted (see tuning procedure).

AUDIO CIRCUITS: Inability to obtain modulation when following the procedure outlined in the tuning instructions could be indicative of trouble in the speech amplifier or modulator circuits, or may simply show a defect in the microphone or cable. Isolate the trouble by disconnecting the microphone connector at the panel. Move the meter switch to MOD. and set the audio GAIN control fully counterclockwise. Touch the center portion of the microphone connector on the panel with your finger and advance the audio gain control slowly. The meter will show modulation if the speech amplifier and modulator circuits are all right, pointing to trouble in the microphone or cable. No reading at all on the meter suggests a lack of screen voltage on the modulator. Check the wiring at the CW-PHONE switch. Screen voltage is obtained at the center tap of the bleeder resistor. If the meter reads up to about 50 milliamperes, however, but does not increase above this value with signal input, the trouble is more than likely in the speech amplifier portion of the circuit.

With the high voltage PLATE switch OFF, speech amplifier output can be checked at the modulator control grids. Care should still be exercised, however, because the low voltage power supply is still on. Connect a headphone or an AC voltmeter from grid to grid on the two modulator tubes and apply audio signal to the input of the speech amplifier by touching your finger to the center part of the microphone connector on the panel. No output under this condition could mean that one of the speech amplifier tubes is defective. Have them tested or substitute new ones. The speech amplifier portion of the transmitter is straightforward audio circuitry and the conventional test procedure for such circuits can be applied. Access to this portion of the circuit may be had by removing all screws from the audio shield plate under the chassis. Remove the screws that hold the plate to the chassis and those that hold the terminal strips on the plate and the plate may be removed without any difficulty. The circuit components will support themselves temporarily.

CABINET ASSEMBLY

- () Place a soft cloth over the workbench or table top so that the paint on the cabinet parts will not become scratched during assembly.
- () Refer to Figure 21 on Page 56 to identify the cabinet sections. Note the difference between the end bells as shown in the figure. Select the right end bell and place on the table with the front toward you as in Figure 22 shown in Page 57.
- () Figure 21 will reveal that the two back corners of the cabinet are the same. Select one of these corners and install as shown in Figure 22A. Use the blunt pointed sheet metal screws and speednuts to fasten these parts together.
- () Figure 22B shows how the corners and panels are interlocked. With this in mind, mount the back panel with the holes to the left as shown in Figure 22C. Use the same type sheet metal screws with speednuts for this and all subsequent assembly steps.
- () Now install the other rear corner in the same fashion, making sure that it interlocks with the back panel.
- () Select the top panel and mount as shown in Figure 22D, again making sure that the panel interlocks with the corner.
- () Now select the top front corner and note that it differs from the back corners and the bottom front corner. Install it as shown in Figure 22E, interlocking with the top panel.
- () Now install the bottom panel and the remaining front corner as shown in Figure 22E.

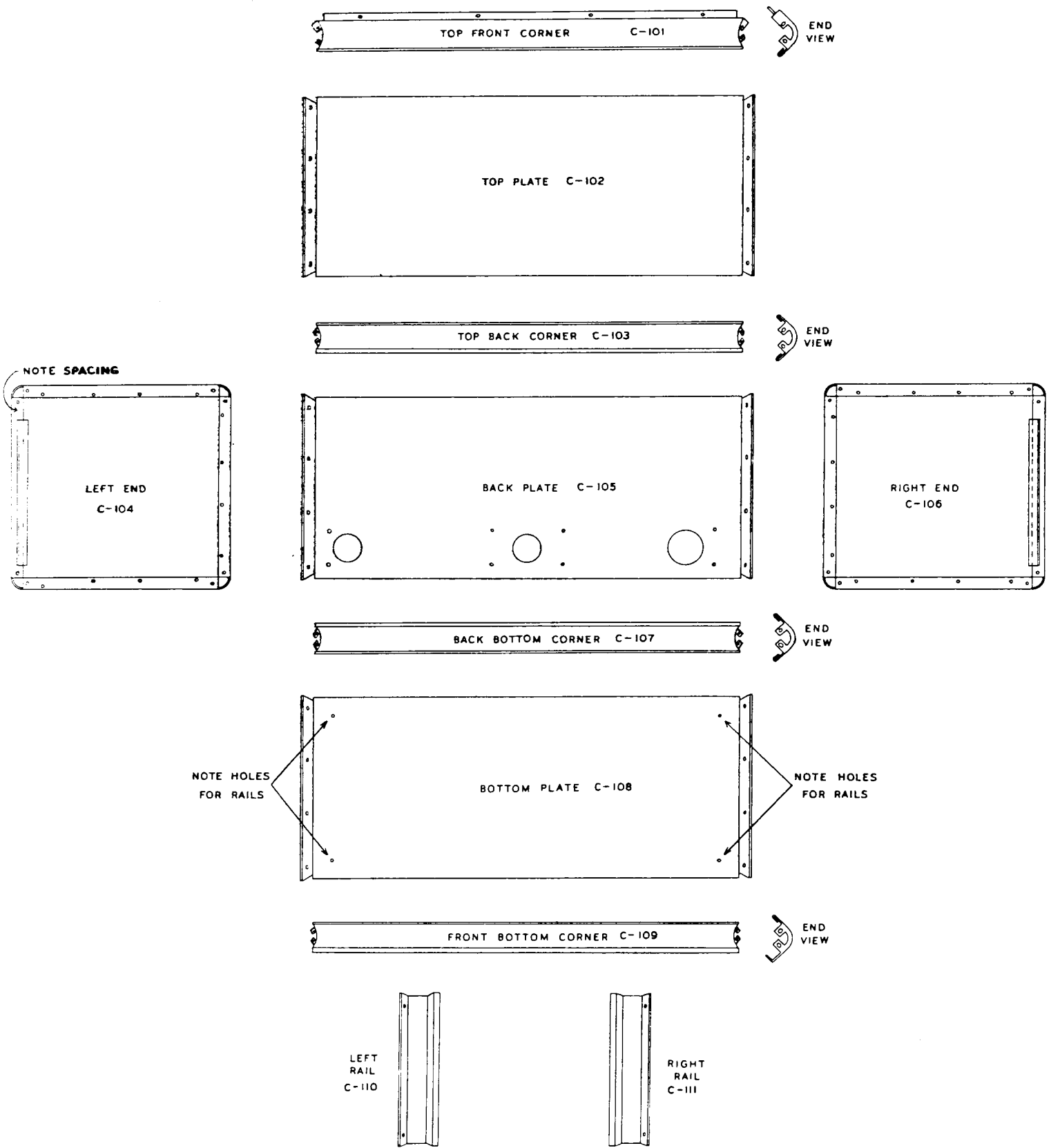

Figure 21

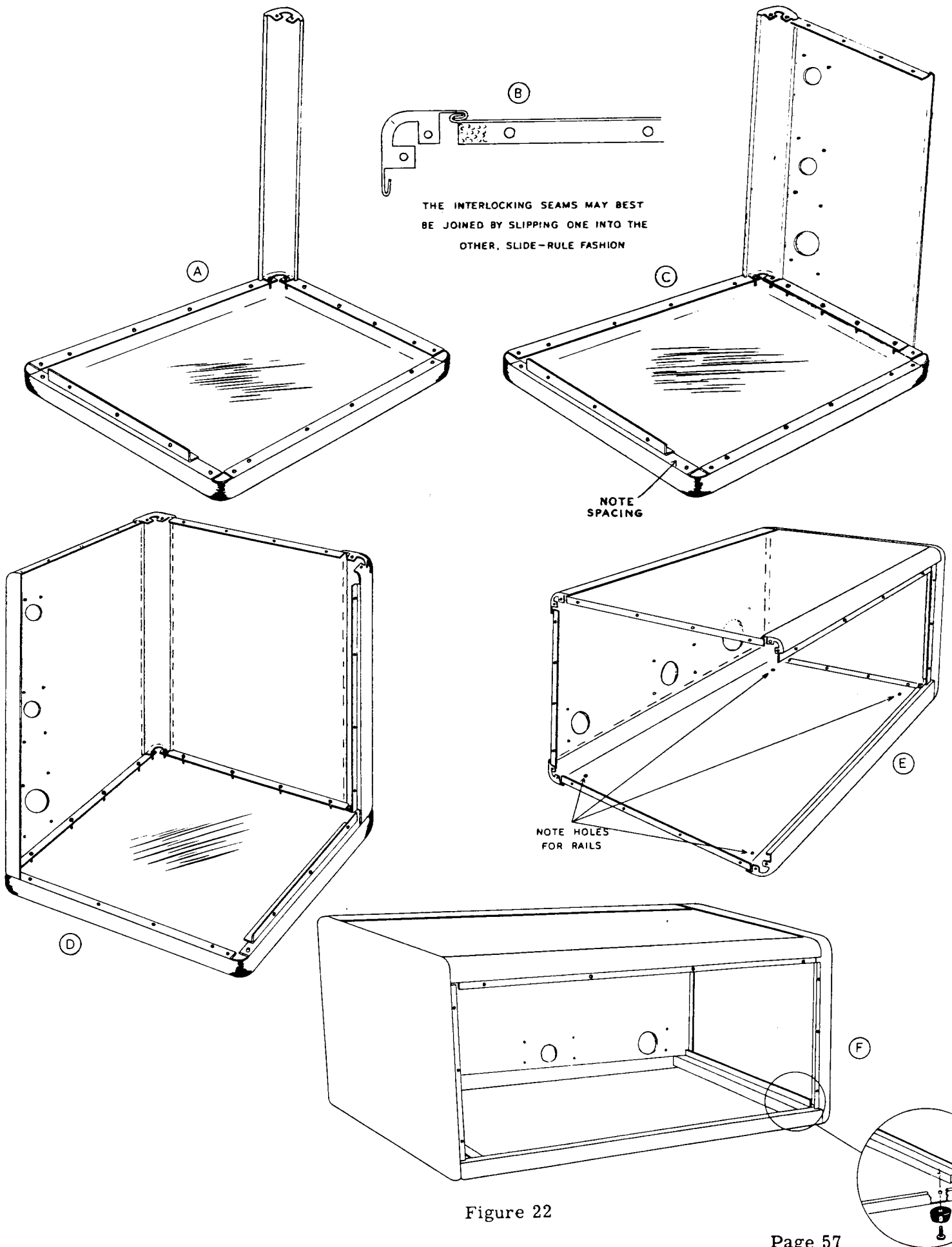

Figure 22

- () Install the left end bell using the same hardware as with the right end bell. Make sure that each corner is interlocked with its adjacent panel or panels before tightening screws. This can best be accomplished by placing the left end bell down flat on the table and lowering the rest of the assembly onto it.
- () Complete the cabinet by installing the bottom rails and rubber feet as shown in Figure 22F. Use the large #10 sheet metal screws through the feet, the bottom panel and into the rails.
- () The transmitter can now be installed in the cabinet. Place the transmitter chassis in front of the cabinet and pass the line cord plug through the left hole in the back panel. Now slide the transmitter chassis onto the rails and into the cabinet while guiding the line cord through the back hole. Use ten #10-32 phillips head screws to fasten the front panel to the case and eight #10 sheet metal screws through the back panel of the case into the back chassis apron.

INSTALLATION AND OPERATION

NOTE: It should be noted that an Amateur Radio Operator and Station License is required to place this transmitter on the air. Information regarding licensing and amateur frequency allocations may be had from publications of the Federal Communications Commission or the American Radio Relay League.

This transmitter can be used for novice operation only if the following three requirements are met: (a) CW operation only. (b) Crystal control only, on assigned novice frequencies. (c) Reduced output power - plate power input must be kept below 75 watts by light loading on the final amplifier stage. Plate current should be held below 90 to 95 milliamperes.

GROUNDING: The importance of a good ground that presents low impedance at all frequencies cannot be emphasized too strongly. What may be a perfectly satisfactory ground at 160 meters could place the transmitter considerably above ground at the higher RF frequencies. As an example, the length of the ground wire is sometimes critical. An 8 foot wire from the transmitter to ground would be a direct short at 160 meters but becomes one-quarter wave length at 10 meters and therefore places the chassis at a high RF potential. Some hints that will be of assistance in obtaining a good ground are:

1. Connection for the ground should be made to cold water or well pipes and/or multiple pipes or rods driven approximately eight or more feet into moist earth. A salt solution poured around the ground rods will further increase the conductivity to ground. A more elaborate installation might include a system of wires approximately one-quarter wave length long laid a few inches under the surface of the earth in a grid or radial pattern. The use of one or all of these grounding systems may be combined to form a good ground reference.
2. The electrical connection to the ground point should consist of a short heavy conductor (#12 wire or heavier, or copper braid). If a short ground wire is difficult to obtain because of transmitter location, several leads of random length may be used. The use of random leads lessens the possibility that all leads should become one-quarter wave length at the frequency of operation. If the transmitter becomes hot at one particular frequency, the addition of a ground wire cut to one-half wave length at this frequency may clear up the difficulty.

Some of the symptoms of inadequate grounding are manifested in the form of:

1. Inability to load the antenna properly.
2. High RF potentials on the chassis or case of the transmitter.
3. Undue voltage strain on output circuit components.
4. Final plate current reading affected by touching the panel or case.

LOCATION: The transmitter should be located where free circulation of air is possible and objects should not be placed on the case as this might restrict the circulation of air. Good ventilation is essential to insure maximum component life. A table or desk of adequate strength must be used to withstand the weight of the transmitter. The considerations mentioned with regard to grounding will also affect the selection of a good location, as will the point of entry of the antenna feeder.

OPERATION: The tuning procedure outlined previously will also apply when loading an actual antenna. Some special cases involving particular antenna types will require special consideration and will be covered under **ANTENNAS**.

A point not covered under the tuning procedure is the method by which the VFO may be beat against an incoming signal without placing the transmitter on the air. This is desirable to place the transmitter on the same frequency as the received signal. When operating phone, with the **PLATE** switch **OFF**, move the **CW-PHONE** switch to **CW** position. This energizes the first three stages of the transmitter circuit. Enough signal will ordinarily be picked up by the receiver under these conditions that the VFO can be tuned for zero beat on the receiver with the incoming signal. If the frequency excursion is more than a few kilocycles, it will be necessary to retune the driver stage. Return the **CW-PHONE** switch to **PHONE** position. When the transmitter is again placed on the air, the final amplifier tuning should be touched up appropriately to compensate for the frequency change

When operating **CW**, simply depressing the key (with the **PLATE** switch **OFF**) will allow the operator to zero beat with the incoming signal on the receiver. Here again, if the frequency change is more than a few kilocycles, the driver and final stages should be retuned as outlined previously.

REMOTE CONTROL SOCKET: See Figure 23 for a diagram of this socket. This is the octal socket located on the back chassis apron. It provides connections for external duplication of the functions of the plate switch and provides 110 volts for antenna relay or receiver muting relay operation when the plate switch is on. In addition, audio output up to 80 watts at 500 Ω can be brought out from this socket for excitation of a higher power modulator. Pin 8 provides an auxiliary ground in the event that shielded cable is used for remote operation.

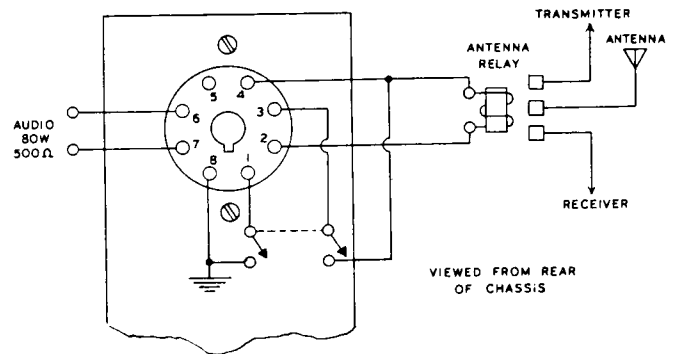

Figure 23

Should the **DX-100** be used as an exciter for a larger transmitter, RF excitation is available at the antenna output connector. Audio at 500 Ω is available at the octal socket providing a slight circuit modification is first accomplished. To do this, refer to Pictorials 2 and 5 and locate terminal strip **FF** on the chassis base. To remove the high voltage from the modulation transformer secondary, clip the jumpers between lugs 1 and 2 and 4 and 5 on strip **FF**. Install jumpers between lug 3 of **FF** and lug 1 of **GG** and between lug 4 of **FF** and lug 3 of **GG**. Then audio will be available between pins 6 and 7 of the remote socket.

An external switch may be placed in parallel with the plate switch by connection to pins 3 and 4 of the remote socket. When using a remote plate switch for phone operation, a double pole-single throw switch or relay must be used to perform the full function of the plate switch. One set of contacts completes the circuit between pins 3 and 4 of the remote socket, while the other set completes the circuit at pins 1 and 8.

For operation of an antenna relay or receiver muting relay, 110 volts is available between pins 2 and 4 of the remote socket when the plate switch is on and is removed when the plate switch is off.

ANTENNA CONSIDERATIONS WITH REGARD TO THE **DX-100** TRANSMITTER

Although a Pi network tank circuit can and will abolish the necessity of a separate antenna coupler, and even aid in the suppression of harmonics, it is not a "cure all" for antenna matching and never will be. It has definite limitations regarding both the impedance and reactance that it can handle.

The coarse loading step-switch and the fine loading variable capacitor of the DX-100 will match antenna impedances in the range of 50 to 600 ohms, providing there is no capacitive or inductive reactance to tune out.

A transmitter, regardless of power, is no better than its radiator, and it is far more practical to increase antenna efficiency than to increase power. An example of this is a rotary beam with a 9 DB gain. This antenna would make the effective radiated power of the DX-100 equal to 800 watts.

One step toward efficient radiation is to choose an antenna which is resonant at the frequency used and presents little or no reactance to the transmitter.

High reactance in the antenna feed system is usually synonymous with high SWR (standing wave ratio.) This means that a good percentage of the power from the transmitter is being reflected back from the antenna. Not only does this seriously impair the signal output but also can result in high voltages or currents appearing in the transmitter output circuits. This effect can cause extensive damage to the final amplifier components, and is often a cause of TVI.

Since there is no way of anticipating the type of antenna which will be used in conjunction with this transmitter, or even the individual characteristics of each installation, the following will be a general description of the advantages of some types and the probable objections of others.

END-FED HERTZ AND MARCONI ANTENNAS

This type of antenna consists merely of a single wire from one-fourth wave length long to any even multiple thereof. One end of the wire is coupled to the transmitter and the other end supported in space. If this antenna is operated against ground, it is known as a Marconi antenna, while if the length is one-half wave length or more, it is known as a Hertz antenna. The greatest disadvantage of feeding a single wire is the necessity of bringing part of the radiating element into the radio room where its proximity to nearby objects increases losses. The greatest advantage of such an antenna is the simplicity with which it may be constructed and its compact size where space is at a premium.

In general any antenna consisting of a single wire, end fed, will result in a high impedance and indeterminate reactance at the transmitter. This often results in very high voltages. In this case, a separate coupler should be used to bring the impedance down to a range the Pi network will accept.

ANTENNAS HAVING FEED SYSTEMS

In the average station it will be found expedient to have the radiating portion of the antenna some distance from the transmitter. This statement assumes that the amateur will have his antenna up high and clear of nearby objects, whereas the actual transmitter may be in the basement or any other room in the home. In such case, some form of transmission line must be used to connect the transmitter efficiently to the antenna. In many instances, the transmission line is of the "balanced" type in which neither leg of the line is grounded. Such transmission lines may be either tuned or untuned, but in either case, a balanced line must be fed through an antenna coupler or "balun" coils. The coupler also provides the means for matching the impedance of the antenna feed line. A typical antenna coupler circuit is shown in Figure 24 on Page 61.

Basically the antenna coupler is an impedance transformer, transforming the impedance of the transmitter to the impedance of the transmission line and antenna system. Referring to Figure 24, coil L1 should match the impedance of the coaxial cable as closely as possible at the frequency of operation. The circuit consisting of L2, C1 and C2 must tune to the transmitter frequency. If it is desired to series tune the antenna, the shorting bar between 3 and 4 is opened and the transmission line connected at these points. For parallel tuning, 3 is shorted to 4 and the transmission line connected to 1 and 2. Taps are provided on the coil L2 to facilitate matching the transmission line. Such a unit can be built up from this or other suggested circuits or may be purchased commercially as a completed unit.

Folded dipoles having 300 ohm ribbon for a feed line are very conveniently fed by using Balun coils. These coils convert the 300 ohm balanced line to a 72 ohm unbalanced coaxial line and are effective from frequencies of 1.8 to 30 MC. The folded dipole is primarily a one-band antenna, and is useful in preventing harmonic radiation.

There is a modified Windom antenna which is fed with 300 ohm ribbon. It resembles a dipole fed off-center with a balanced feed line and the off center point is supposedly chosen to present a 300 ohm impedance to the feed point. This antenna is the subject of a great deal of controversy and we do not recommend its use. In contrast many hams enjoy good results with it.

The single wire dipole antenna fed with 72 ohm coax may be used as a multi-band antenna and being coaxial fed can be connected directly to the transmitter. However, the SWR will run a little high on bands other than the design center.

Vertical antennas with a proper matching network at the base may be coax fed and will operate over several bands with good results.

A check of older issues of CQ or QST will reveal descriptions of several vertical systems.

For the higher frequency bands Beams, Cubical Quads, and Rhombics will give the best results. The feed and matching systems vary considerably and the antenna handbook should be consulted for more complete information.

The design center of an antenna should be based on minimum SWR or standing wave ratio. The optimum, of course, would represent a ratio of 1 to 1 which means that all of the energy reaching the antenna is being radiated, with none reflected back to the transmitter.

Whatever the antenna type or design, a little research on the results to be expected from it and some experimentation at low power levels may prevent serious damage to your new transmitter. A reflected power meter will give an instantaneous reading of antenna efficiency.

When loading to either a balanced or an unbalanced system, the maximum loading point of 250 milliamperes in the final stage should not be exceeded. In many instances, the transmitter will load to a higher level, but the harmonic suppression of the pi network is better if the output coupling capacitor is not reduced to absolute minimum value. Then too, the extra 10 or 15 watts which would be gained by maximum loading would not make any appreciable difference at the receiving end of the transmission.

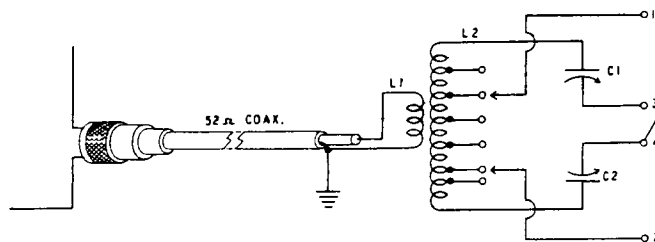

Figure 24

LOW PASS FILTERS: The harmonic rejection of the pi network output circuit of the DX-100 is excellent and will attenuate harmonics considerably when the transmitter is properly grounded and carefully tuned. However, additional harmonic attenuation may be had with the use of a low-pass filter between the output of the transmitter and the feed line or antenna. Such a filter should be designed to handle the maximum power output of the transmitter and must be operated into its nominal impedance.

Needless to say, no attempt has been made here to cover the theory of antennas, as such, since much has been written on this subject. The possibilities in different antenna types and different feed systems are many and the factors mentioned herein only scratch the surface of the subject. Each operator will need to do his own investigation into the advantages and disadvantages of the various systems to determine just which one will best suit his needs. Basic data is available through the Radio Amateur Handbooks and other technical publications.

Some formulas that should prove helpful are listed as follows:

$$1 \text{ wave length in space} = \frac{300,000 \text{ meters}}{F_{kc}}$$

$$\text{Center fed dipole one-half wave long (length in feet)} = \frac{468}{F_{mc}}$$

$$\text{Folded dipole one-half wave long (length in feet)} = \frac{462}{F_{mc}}$$

$$\text{Zepp antenna one-half wave long (length in feet)} = \frac{492}{F_{mc}}$$

REPLACEMENTS

Material supplied with Heathkits has been carefully selected to meet design requirements and ordinarily will fulfill its function without difficulty. Occasionally improper instrument operation can be traced to a faulty tube or component. Should inspection reveal the necessity for replacement, write to the Heath Company and supply all of the following information:

- A. Thoroughly identify the part in question by using the part number and description found in the manual parts list.
- B. Identify the type and model number of kit in which it is used.
- C. Mention the order number and date of purchase.
- D. Describe the nature of defect or reason for requesting replacement.

The Heath Company will promptly supply the necessary replacement. Please do not return the original component until specifically requested to do so. Do not dismantle the component in question as this will void the guarantee. If tubes are to be returned, pack them carefully to prevent breakage in shipment as broken tubes are not eligible for replacement. This replacement policy does not cover the free replacement of parts that may have been broken or damaged through carelessness on the part of the kit builder.

SERVICE

In event continued operational difficulties of the completed instrument are experienced, the facilities of the Heath Company Service Department are at your disposal. Your instrument may be returned for inspection and repair for a service charge of \$20.00 plus the cost of any additional material that may be required. **THIS SERVICE POLICY APPLIES ONLY TO COMPLETED INSTRUMENTS CONSTRUCTED IN ACCORDANCE WITH THE INSTRUCTIONS AS STATED IN THE MANUAL.** Instruments that are not entirely completed or instruments that are modified in design will not be accepted for repair. Instruments showing evidence of acid core solder or paste fluxes will be returned not repaired.

The Heath Company is willing to offer its full cooperation to assist you in obtaining the specified performance level in your instrument. Factory repair service is available for a period of one year from the date of purchase or you may contact the Engineering Consultation Department by mail. For information regarding possible modification of existing kits, it is suggested that you refer to any one or more of the many publications that are available on all phases of electronics. They can be obtained at or through your local library, as well as at any electronic outlet store. Although the Heath Company sincerely welcomes all comments and suggestions, it would be impossible to design, test, evaluate and assume responsibility for proposed circuit changes for specific purposes. Therefore, such modifications must be made at the discretion of the kit builder according to information which will be much more readily available from some local source.

SHIPPING INSTRUCTIONS

Before returning a unit for service, be sure that all parts are securely mounted.

**ATTACH A TAG TO THE INSTRUMENT GIVING
NAME, ADDRESS AND TROUBLE EXPERIENCED.**

Pack in a rugged container, preferably wood, using at least three inches of shredded newspaper or excelsior on all sides. **DO NOT SHIP IN THE ORIGINAL KIT CARTON AS THIS CARTON IS NOT CONSIDERED ADEQUATE FOR SAFE SHIPMENT OF THE COMPLETED INSTRUMENT.** Ship by prepaid express if possible. Return shipment will be made by express collect. Note that a carrier cannot be held liable for damage in transit if packing, in HIS OPINION, is insufficient.

SPECIFICATIONS

All prices are subject to change without notice. The Heath Company reserves the right to discontinue instruments and to change specifications at any time without incurring any obligation to incorporate new features in instruments previously sold.

WARRANTY

Heath Company warrants that for a period of three months from the date of shipment, all Heathkit parts shall be free of defects in materials and workmanship under normal use and service and that in fulfillment of any breach of such warranty, Heath Company shall replace such defective parts upon the return of the same to its factory. The foregoing warranty shall apply only to the original buyer, and is and shall be in lieu of all other warranties, whether express or implied and of all other obligations or liabilities on the part of Heath Company and in no event shall Heath Company be liable for any anticipated profits, consequential damages, loss of time or other losses incurred by the buyer in connection with the purchase, assembly or operation of Heathkits or components thereof. No replacement shall be made of parts damaged by the buyer in the course of handling or assembling Heathkit equipment.

NOTE: The foregoing warranty is completely void and we will not replace, repair or service instruments or parts thereof in which acid core solder or paste fluxes have been used.

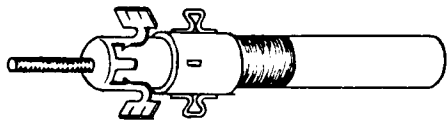

20M SLUG-TUNED COIL
40-62

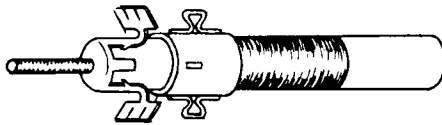

40M SLUG-TUNED COIL
40-63

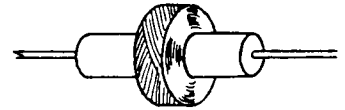

10mh RF CHOKE
45-16



2.5mh RF CHOKE
45-14



1.1mh RF CHOKE
45-4



28µh RF CHOKE
45-18

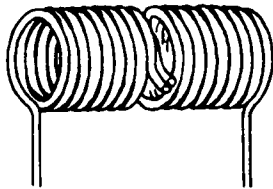

10-15M DRIVER COIL
40-61

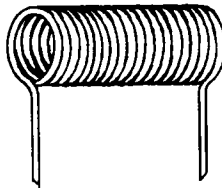

LINE FILTER CHOKE
45-17

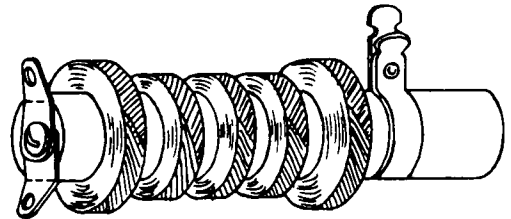

1mh RF CHOKE 500MA
45-15

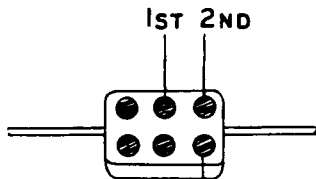

MULTIPLIER
MICA CAPACITOR

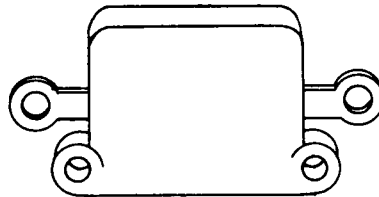

200µmf MICA CAPACITOR
20-44

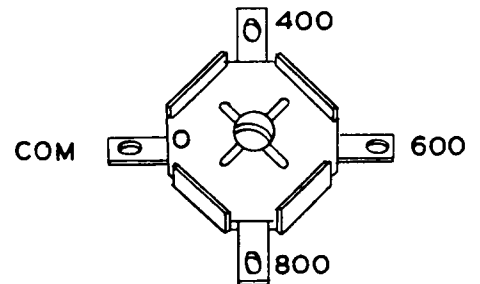

SPECIAL CAPACITOR
400-600-800
20-45

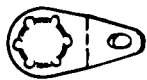

*6 REGULAR
259-1

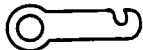

*6 SMALL
259-6



TENSION NUT
252-19

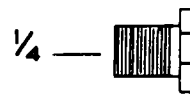

1/4 — 455-9

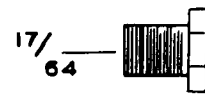

17/64 — 455-10

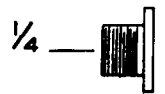

1/4 — 455-6

BUSHINGS

SOLDER LUGS

(TWICE SIZE)



1/2 WATT RESISTOR



1 WATT RESISTOR



2 WATT RESISTOR

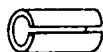

SPLIT BUSHING
455-11

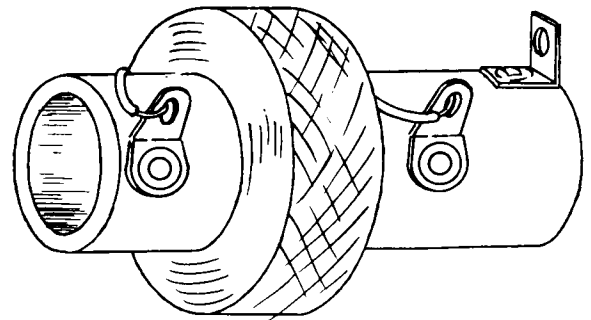

160 M PLATE COIL
40-59

PART No.	PARTS Per Kit	DESCRIPTION	PART No.	PARTS Per Kit	DESCRIPTION
Resistors			Coils-Chokes-Transformers		
1-7	1	680 Ω 1/2 watt	40-54	1	160 M VFO coil
1-9	2	1 K Ω 1/2 watt	40-55	1	40 M VFO coil
1-16	3	4.7 K Ω 1/2 watt	40-57	1	Driver coil
1-22	1	22 K Ω 1/2 watt	40-58	1	Plate coil
1-46A	1	27 K Ω 1 watt	40-59	1	160 M plate coil
1-25	2	47 K Ω 1/2 watt	40-60	1	10 M plate coil
1-26	3	100 K Ω 1/2 watt	40-61	1	10-15 M driver coil
1-33	4	470 K Ω 1/2 watt	40-62	1	20 M slug tuned coil
1-44	2	2.2 K Ω 1/2 watt	40-63	1	40 M slug tuned coil
1-1A	1	470 Ω 1 watt	45-4	2	1.1 mh RF choke
1-2A	1	1 K Ω 1 watt	45-13	2	47 Ω parasitic choke
1-23A	2	2.2 K Ω 1 watt	45-14	1	2.5 mh RF choke
1-6B	1	27 K Ω 2 watt	45-15	1	1 mh 500 ma RF choke
2-94	2	.1 Ω 1/2 watt precision	45-16	1	10 mh RF choke
2-95	1	1.02 Ω 1/2 watt precision	45-17	9	Line filter choke
2-96	1	5.55 Ω 1/2 watt precision	45-18	1	28 μ h RF choke
2-10B	1	1 megohm 2 watt precision	46-10	1	Plate filter choke 400 ma
3-8J	1	15 K Ω 5 watt	46-11	1	LV filter choke 150 ma
3-7J	2	10 K Ω 10 watt	51-22	1	Modulation transformer
3-2Y	1	30 K Ω 50 watt center-tapped	51-23	1	Driver transformer
3-13G	1	6.5 K Ω 7 watt wire wound	54-30	1	Plate transformer
			54-31	1	Power transformer
Capacitors			Sockets-Terminal Strips-Wafers-Knobs		
20-1	3	47 μ mf silver mica 600 volt	431-1	5	1-lug terminal strip
20-11	1	100 μ mf mica 600 volt	431-10	7	3-lug terminal strip
20-33	3	.001 μ fd mica 600 volt	431-11	2	5-lug terminal strip
20-42	4	510 μ mf silver mica 600 volt	431-12	5	4-lug terminal strip
20-44	1	200 μ mf mica 600 volt type H	431-19	1	5-lug "Jones" terminal strip
20-45	1	400-600-800 μ mf special	431-20	1	6-lug terminal strip
20-48	2	.001 μ fd mica 2000 volt	432-3	1	Mike connector
20-50	1	7.5 μ mf silver mica 600 volt	434-34	3	7-pin miniature socket
20-51	1	43 μ mf silver mica 600 volt	434-35	1	7-pin miniature ceramic socket
21-22	1	220 μ mf disc ceramic	434-38	4	Crystal socket
21-25	2	1300 μ mf disc ceramic	434-44	1	Pilot light socket
21-27	28	.005 μ fd disc ceramic	434-53	3	Octal ceramic saddle socket
21-28	1	10 μ mf N750 ceramic	434-54	3	Octal ceramic wafer socket
21-29	1	4.7 μ mf N750 ceramic	434-55	2	7-pin ceramic wafer socket
21-38	1	.02 μ fd disc ceramic 1600 volt	434-56	4	9-pin miniature socket
23-11	1	.1 μ fd 600 volt paper	434-57	1	Candelabra socket
23-53	2	.1 μ fd 400 volt paper	436-4	1	Phone jack (closed circuit)
25-10	1	20-20-20 μ fd 450 volt elec.	436-5	1	Coaxial connector
25-19	2	20 μ fd 150 volt elec.	438-11	1	Fuse plug
25-34	2	125 μ fd 450 volt elec.	100-M60	3	Pointer knob
25-35	3	2 μ fd 50 volt elec.	462-19	3	Pointer knob (small)
26-18	1	250 μ mf variable	462-26	1	Round knob (large)
26-20	1	11-35 μ mf differential	462-32	2	Concentric knob
26-22	1	75 μ mf variable	462-36	2	Concentric knob (small, red)
26-23	2	9 μ mf midget variable	481-1	1	Metal capacity mounting wafer
26-24	1	20 μ mf midget variable	481-3	2	Insulated capacity mounting wafer
26-25	1	350 μ mf variable			

PART No.	PARTS Per Kit	DESCRIPTION
----------	---------------	-------------

Hardware Package #1

250-8	2	#6 sheet metal screw
250-18	4	8-32 x 3/8 RH machine screw
250-31	21	6-32 x 1/4 RH machine screw
250-40	1	6-32 x 1 1/2 RH machine screw
250-43	1	8-32 x 1/4 set screw
250-49	6	3-48 x 1/4 BH machine screw
250-52	4	4-40 x 1/4 BH machine screw
250-54	1	10-32 x 5/8 RH machine screw
251-1	2	6-32 spade screw
252-1	6	3-48 nut
252-2	4	4-40 x 1/4 nut
252-3	21	6-32 nut
252-4	4	8-32 nut
252-5	2	10-32 nut
252-7	4	3/8-32 nut
252-19	2	#6 tension nut
253-10	4	3/8 flat washer
253-23	4	3/16 x 1/16 fiber washer
254-1	20	#6 lockwasher
254-2	4	#8 lockwasher
254-3	1	#10 lockwasher
254-4	4	3/8 lockwasher
254-7	4	#3 lockwasher
255-6	1	1 1/8 spacer
259-1	8	#6 solder lug
259-5	1	#10 solder lug

Hardware Package #2

250-9	10	6-32 x 3/8 RH machine screw
250-10	10	6-32 x 1/2 BH machine screw
250-18	24	8-32 x 3/8 RH machine screw
250-29	2	6-32 x 3/4 RH machine screw
250-31	17	6-32 x 1/4 RH machine screw
250-34	4	4-40 x 1/2 RH machine screw
250-49	14	3-48 x 1/4 BH machine screw
252-1	14	3-48 nut
252-3	34	6-32 nut
252-4	24	8-32 nut
252-7	1	3/8-32 nut
252-15	4	4-40 x 3/16 nut
253-1	22	#6 fiber washer
254-1	20	#6 lockwasher
254-2	23	#8 lockwasher
254-4	1	3/8 lockwasher
259-1	16	#6 solder lug
259-5	1	#10 solder lug

PART No.	PARTS Per Kit	DESCRIPTION
----------	---------------	-------------

Hardware Package #3

250-8	10	#6 sheet metal screw
250-13	4	6-32 x 1 RH machine screw
250-18	12	8-32 x 3/8 RH machine screw
250-31	17	6-32 x 1/4 RH machine screw
250-43	10	8-32 x 1/4 set screw
250-50	10	10-32 x 3/8 Philips machine screw
250-51	8	#10 sheet metal screw
250-56	4	6-32 x 1/4 BH machine screw
251-1	5	#6 spade screw
252-3	25	6-32 nut
252-4	12	8-32 nut
252-7	12	3/8-32 nut
253-1	1	#6 fiber washer
253-6	1	#10 fiber washer
253-10	8	3/8 flat washer
254-1	26	#6 lockwasher
254-2	12	#8 lockwasher
254-4	11	3/8 lockwasher
255-5	4	#6 x 3/4 spacer
259-1	9	#6 solder lug
259-6	1	#6 solder lug (small)
455-11	2	3/16 - 1/4 split bushing

Controls-Switches

10-15	1	.5 megohm potentiometer
10-35	1	.5 megohm potentiometer (slotted)
11-20	1	25 K Ω 4 watt potentiometer
61-4	1	SPST toggle switch
61-3	1	DPST toggle switch
63-94	1	2 pole, 5 pos. meter switch
63-95	1	3 pole, 2 pos. CW-phone switch
63-96	1	3 deck, 7 pos. band switch
63-97	1	1 pole, 11 pos. loading switch
63-98	1	1 pole, 5 pos. Xtal-VFO switch
63-99	1	2 pole, 3 pos. VFO switch

Meters-Tubes

407-30	1	1 ma meter
411-11	1	6AU6 tube
411-26	1	12AX7 tube
411-35	1	5V4 tube
411-40	1	6AL5 tube
411-47	2	1625 tube
411-59	1	OA2 tube
411-60	1	6AQ5 tube
411-69	2	12BY7 tube
411-75	2	6146 tube
411-76	2	5R4GY tube
411-77	1	5763 tube
412-1	1	#47 pilot light
412-2	1	3 watt 110 volt light
413-2	1	Dial light jewel
421-4	2	8 amp fuse 3 AG

<u>PART No.</u>	<u>PARTS Per Kit</u>	<u>DESCRIPTION</u>	<u>PART No.</u>	<u>PARTS Per Kit</u>	<u>DESCRIPTION</u>
Sheet Metal Parts			Cabinet		
100-M56	1	Chassis base	90-35	1	Cabinet
100-M57	1	VFO sub-chassis	Consisting of:		
200-M83	1	Chassis top		2	End bell
203-M72F112	1	Panel		2	Back corner
204-M68	2	Light shield bracket		1	Top corner
204-M85	1	Potentiometer mounting bracket		1	Bottom corner
204-M86	1	Switch mounting bracket		1	Back plate
204-M87	1	Capacitor mounting bracket		1	Top plate
205-M39	1	6146 sub-chassis plate		1	Bottom plate
205-M40	1	Crystal mounting plate		2	Guide rail
205-M45	1	Meter switch assy. template		1	Top panel bracket
206-M31	1	VFO sub-chassis shield		2	Side panel bracket
206-M32	1	Final amplifier shield		40	#6 x 3/8 sheet metal screw
206-M33	1	Driver shield		40	#6 speed nut
206-M34	1	Audio shield		13	#8 x 3/8 sheet metal screw
Miscellaneous				4	#10 x 3/4 sheet metal screw
71-2	4	Feedthrough insulator		4	Rubber feet
71-4	2	Stand-off insulator			
73-1	5	3/8" rubber grommet			
73-2	4	3/4" rubber grommet			
73-4	2	5/16" rubber grommet			
89-4	1	Line cord			
100-M43	1	Dial plate			
100-M44	1	Dial drive			
100-M58	1	VFO switch drive plate			
100-M59	1	Bandswitch drive plate			
100-61	1	Cable harness			
206-4	1	length Spirashield			
206-25	1	1 3/4" tube shield			
206-M26	1	Plastic light shield			
212-M3	1	Silver plate ground strap			
250-55	1	3/16-24 x 4 1/2 bolt			
252-18	1	3/16-24 nut			
260-10	2	Ceramic plate cap			
260-12	2	Aluminum plate cap			
340-1	1	length #14 tinned wire			
340-2	1	length #20 tinned wire			
344-1	7	lengths Hookup wire (7 colors)			
346-1	1	length 1/8" sleeving			
346-5	1	length Plastic tubing			
391-2	1	Nameplate (black)			
453-17	1	Extension shaft 1/4 x 9			
453-18	1	Extension shaft 1/4 x 6 11/16			
455-6	1	3/8 VFO shaft bushing			
455-9	3	3/8-32 x 1/4 ID bushing			
455-10	2	3/8-32 x 17/64 ID bushing			
456-1	4	1/4" flexible coupling			
464-M3	1	Plastic dial			
475-3	2	Iron core slug			
595-104	1	Instruction manual			

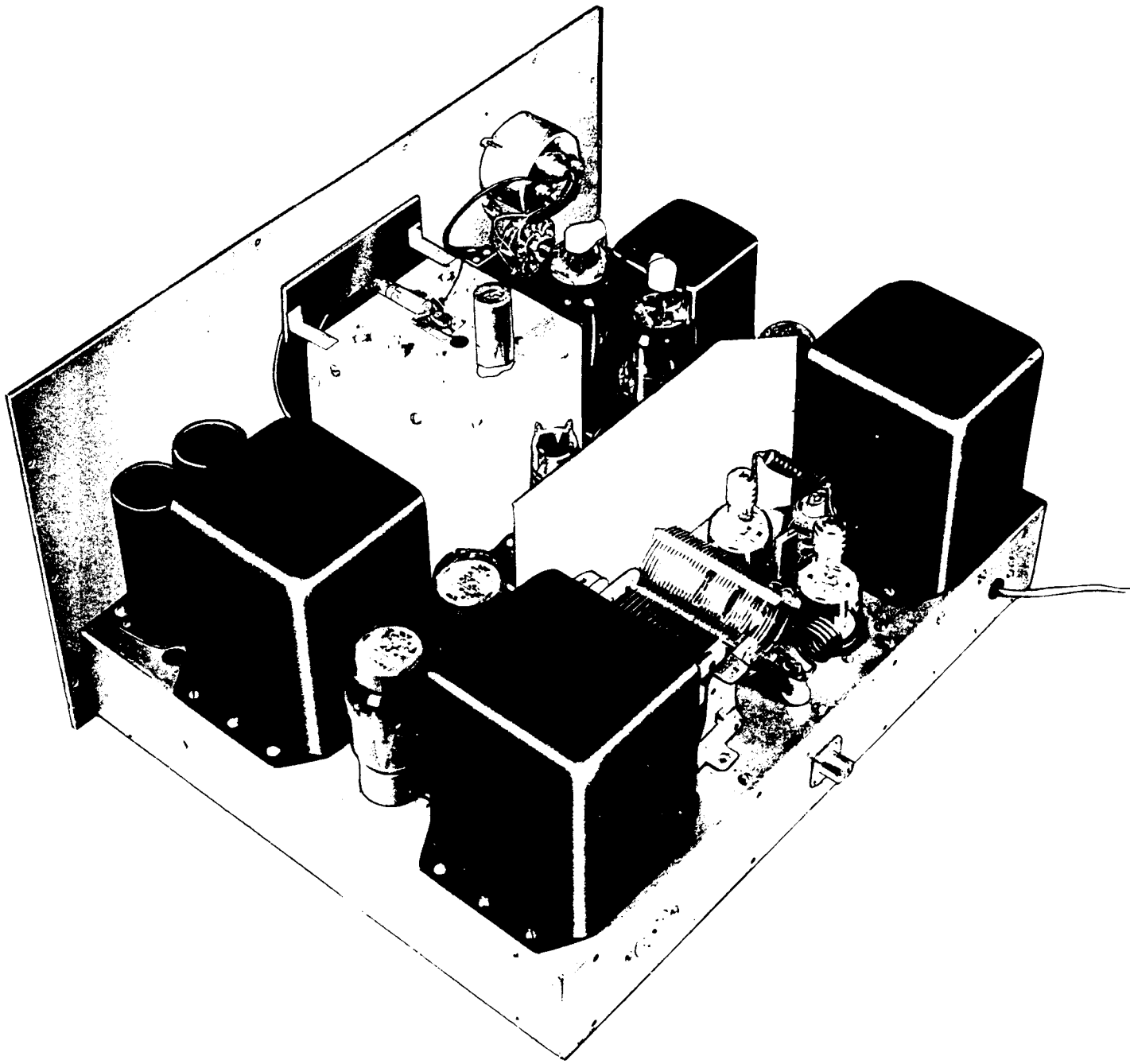

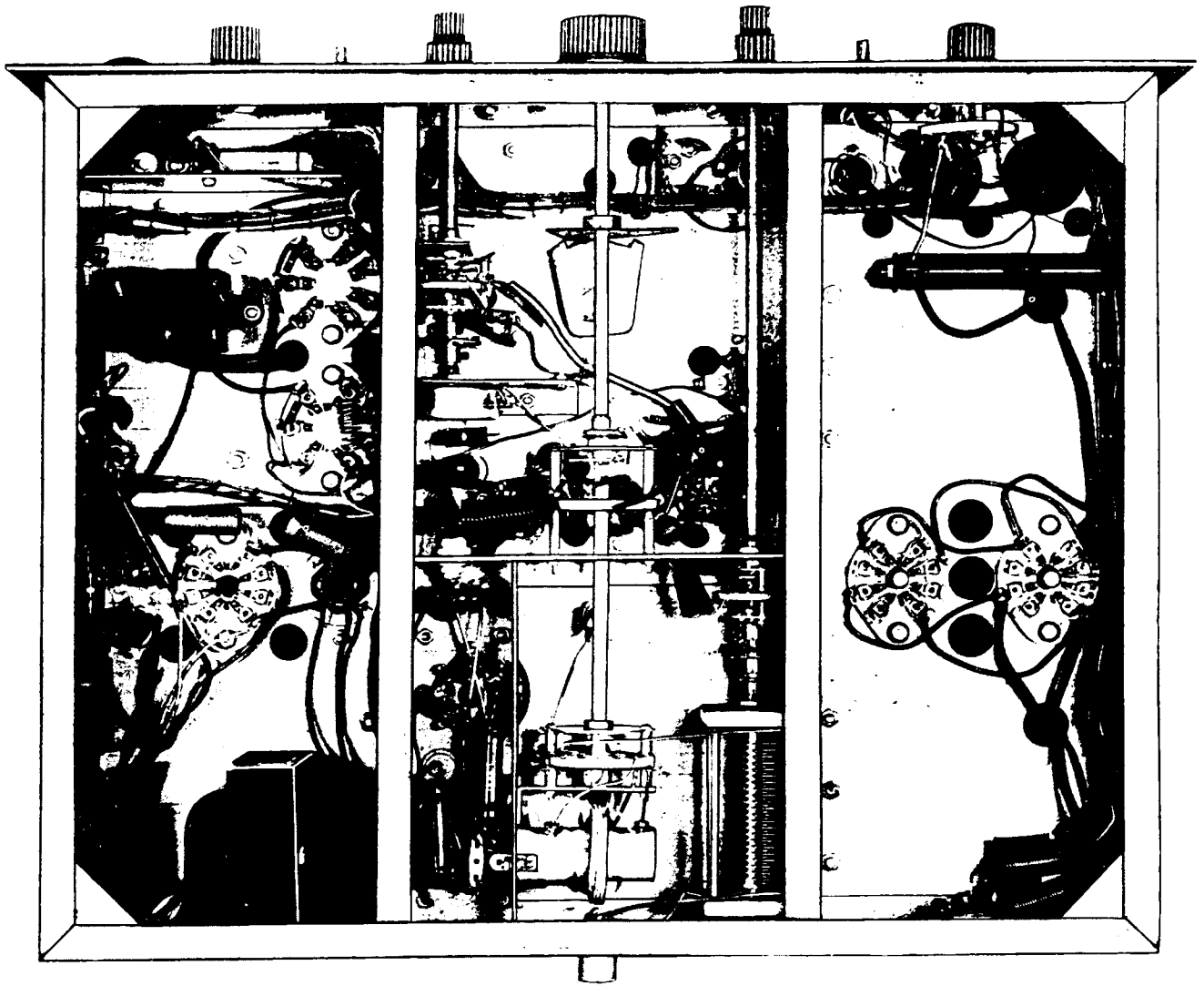

CUSTOMER SERVICE

REPLACEMENT PARTS

Please provide complete information when you request replacements from either the factory or Heath Electronic Centers. Be certain to include the **HEATH** part number exactly as it appears in the parts list.

ORDERING FROM THE FACTORY

Print all of the information requested on the parts order form furnished with this product and mail it to Heath. For telephone orders (parts only) dial 616 982-3571. If you are unable to locate an order form, write us a letter or card including:

- Heath part number.
- Model number.
- Date of purchase.
- Location purchased or invoice number.
- Nature of the defect.
- Your payment or authorization for COD shipment of parts not covered by warranty.

Mail letters to: Heath Company
Benton Harbor
MI 49022
Attn: Parts Replacement

Retain original parts until you receive replacements. Parts that should be returned to the factory will be listed on your packing slip.

OBTAINING REPLACEMENTS FROM HEATH ELECTRONIC CENTERS

For your convenience, "over the counter" replacement parts are available from the Heath Electronic Centers listed in your catalog. Be sure to bring in the original part and purchase invoice when you request a warranty replacement from a Heath Electronic Center.

TECHNICAL CONSULTATION

Need help with your kit? — Self-Service? — Construction? — Operation? — Call or write for assistance. you'll find our Technical Consultants eager to help with just about any technical problem except "customizing" for unique applications.

The effectiveness of our consultation service depends on the information you furnish. Be sure to tell us:

- The Model number and Series number from the blue and white label.
- The date of purchase.
- An exact description of the difficulty.
- Everything you have done in attempting to correct the problem.

Also include switch positions, connections to other units, operating procedures, voltage readings, and any other information you think might be helpful.

Please do not send parts for testing, unless this is specifically requested by our Consultants.

Hints: Telephone traffic is lightest at midweek — please be sure your Manual and notes are on hand when you call.

Heathkit Electronic Center facilities are also available for telephone or "walk-in" personal assistance.

REPAIR SERVICE

Service facilities are available, if they are needed, to repair your completed kit. (Kits that have been modified, soldered with paste flux or acid core solder, cannot be accepted for repair.)

If it is convenient, personally deliver your kit to a Heathkit Electronic Center. For warranty parts replacement, supply a copy of the invoice or sales slip.

If you prefer to ship your kit to the factory, attach a letter containing the following information directly to the unit:

- Your name and address.
- Date of purchase and invoice number.
- Copies of all correspondence relevant to the service of the kit.
- A brief description of the difficulty.
- Authorization to return your kit COD for the service and shipping charges. (This will reduce the possibility of delay.)

Check the equipment to see that all screws and parts are secured. (Do not include any wooden cabinets or color television picture tubes, as these are easily damaged in shipment. Do not include the kit Manual.) Place the equipment in a strong carton with at least **THREE INCHES** of *resilient* packing material (shredded paper, excelsior, etc.) on all sides. Use additional packing material where there are protrusions (control sticks, large knobs, etc.). If the unit weighs over 15 lbs., place this carton in another one with 3/4" of packing material between the two.

Seal the carton with reinforced gummed tape, tie it with a strong cord, and mark it "Fragile" on at least two sides. Remember, the carrier will not accept liability for shipping damage if the unit is insufficiently packed. Ship by prepaid express, United Parcel Service, or insured Parcel Post to:

Heath Company
Service Department
Benton Harbor, Michigan 49022



HEATH COMPANY • BENTON HARBOR, MICHIGAN
THE WORLD'S FINEST ELECTRONIC EQUIPMENT IN KIT FORM

LITHO IN U.S.A.