

**GENERAL OPERATING INSTRUCTIONS
FOR THE
MODEL CX7 DELUXE INTEGRATED STATION**

JULY 1, 1970



A DIVISION OF ECI (An NCR Subsidiary)

2200 ANVIL STREET N. ST. PETERSBURG, FLORIDA - 33710

TABLE OF CONTENTS

Paragraph		Page
1.1	INTRODUCTION	1-1
1.2	SPECIFICATIONS	1-4
1.2.1	General	1-4
1.2.2	Receiving System	1-4
1.2.3	Transmitting System	1-4
1.3	RECOMMENDED ACCESSORIES	1-5
1.4	OPTIONAL FILTERS AND CRYSTALS	1-5
1.5	PREPARATION FOR USE	1-5
1.5.1	Unpacking	1-5
1.5.2	Normal Operation Interconnections	1-5
1.5.3	Special Purpose Interconnections	1-6
1.5.3.1	Phone Patch Operation	1-6
1.5.3.2	FSK	1-6
1.5.3.3	Linear Amplifier	1-6
2.1	GENERAL	2-1
2.1.1	Operating Position	2-1
2.1.2	Operating Voltage	2-1
2.1.3	Operating Temperature	2-1
2.2	Controls, Connectors, and Indicators	2-1
2.3	Receive Mode Operating Procedures	2-1
2.3.1	General	2-1
2.3.2	Single Channel Receive Mode Operation	2-15
2.3.2.1	Operation of the "AGC" Switch	2-16
2.3.2.2	Operation of the "IF SHIFT" Control	2-16
2.3.2.3	Operation of the "BLANKER" Control	2-16
2.3.3	Dual Channel Receive Mode Operation	2-16
2.3.4	Calibration Using the "PULL TO CALIBRATE" Control	2-17
2.3.4.1	Compensation	2-17
2.3.4.2	Calibration Using "WWV"	2-17
2.3.4.3	Calibrating Internal 100 kHz Standard	2-17
2.4	Transmit Mode Operating Procedures	2-18
2.4.1	General	2-18
2.4.2	Tune Mode Operation	2-21
2.4.3	Normal Transmit Channel Operation	2-22
2.4.3.1	Operating with a VSWR Less than 1.5:1	2-22
2.4.3.2	Operating with a VSWR Exceeding 1.5:1	2-23
2.4.4	Single Sideband Transmission	2-23
2.4.4.1	Manual Keying	2-23
2.4.4.2	VOX-ANTI-VOX Keying	2-23
2.4.4.3	Operation of "CLIPPING" Control	2-24
2.4.5	AM Transmission	2-24
2.4.6	CW Transmission	2-24
2.4.6.1	Normal Telegraph Key Operation	2-24
2.4.6.2	Paddle Key Operation	2-24
2.4.6.3	Offset Channel Operation	2-25
2.4.7	FSK Mode	2-25
2.4.8	Linear Amplifier Operation	2-25

SECTION I

GENERAL DESCRIPTION

1.1 INTRODUCTION

The Signal/One Model CX7, shown in Figure 1-1, is a self-contained, deluxe integrated station, designed for the professional-amateur radio operator. The construction technique utilizes solid-state circuitry throughout, with the exception of the Nixie tubes and the transmitter power amplifier stage which is a ceramic-metal tube. The Model CX7 is capable of operation in the SSB, CW, FSK and compatible AM mode. Frequency coverage includes all the amateur bands between 1.8 and 29.7 MHz with provisions for accepting spare crystals permitting operation in the non-amateur frequencies from 2 to 3, 4 to 7, or 8 to 14 MHz. Two separate VFO's provide the capability of simultaneously receiving two separate frequencies within the same band and transmitting on either. Tuning to the precise frequency is accomplished by observing the arabic numerals being indicated by the Nixie tubes

while adjusting the VFO control for the desired display. Included as standard equipment are the DIGITAL KEYS, VOX, and ANTI-VOX, NOISE BLANKER, RF CLIPPER, and METERING of all critical functions. In reviewing the Model CX7 capabilities it might be discovered that the deluxe integrated station contains features which the average amateur can not presently utilize. However, as operating experience is gained, these features will provide the means to attain professionalism and will prove to be required necessities. The space age technology exhibited in the construction and circuitry will enhance the value of the Model CX7 for many years. Its characteristics far surpass other equipment claiming to set a standard of performance. Numerous amateurs have stated that they would choose not to be active at all if they had to operate without their Model CX7. The complete capabilities can best be understood by reviewing this entire manual.

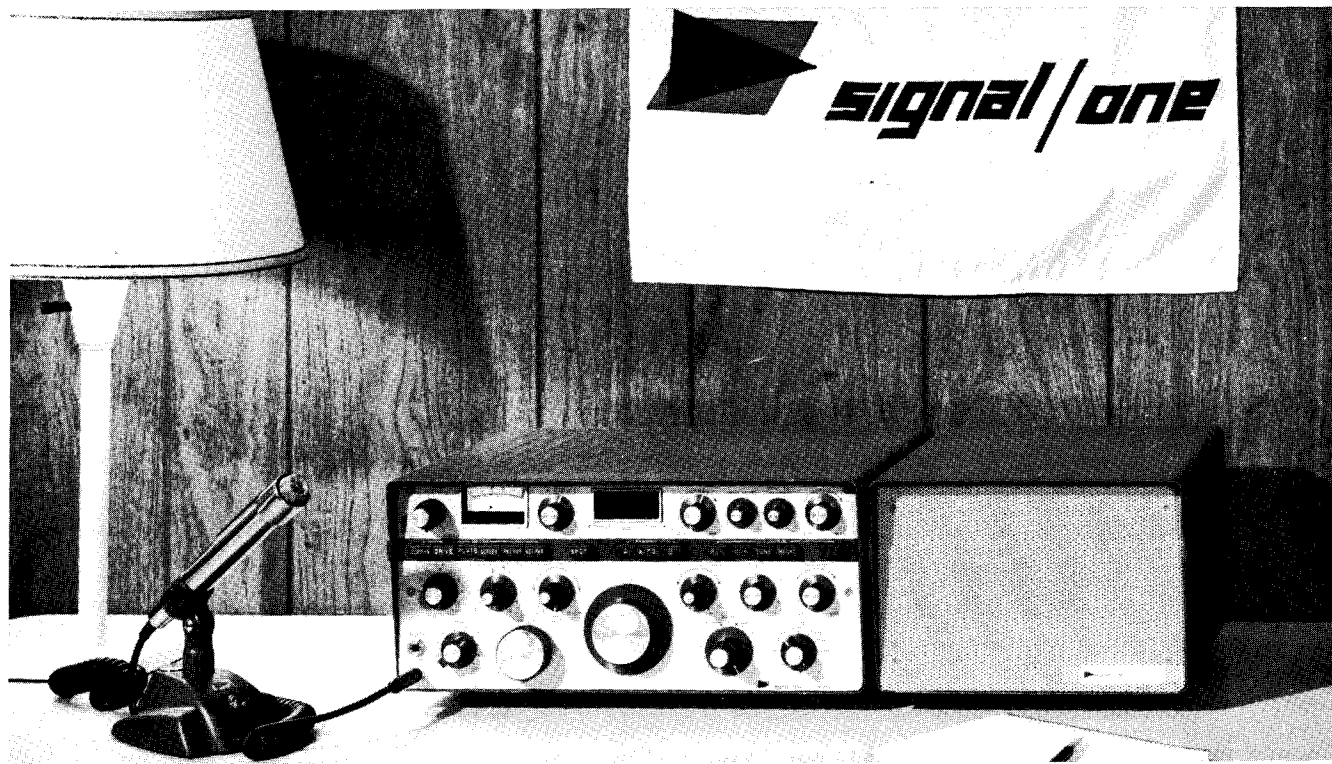
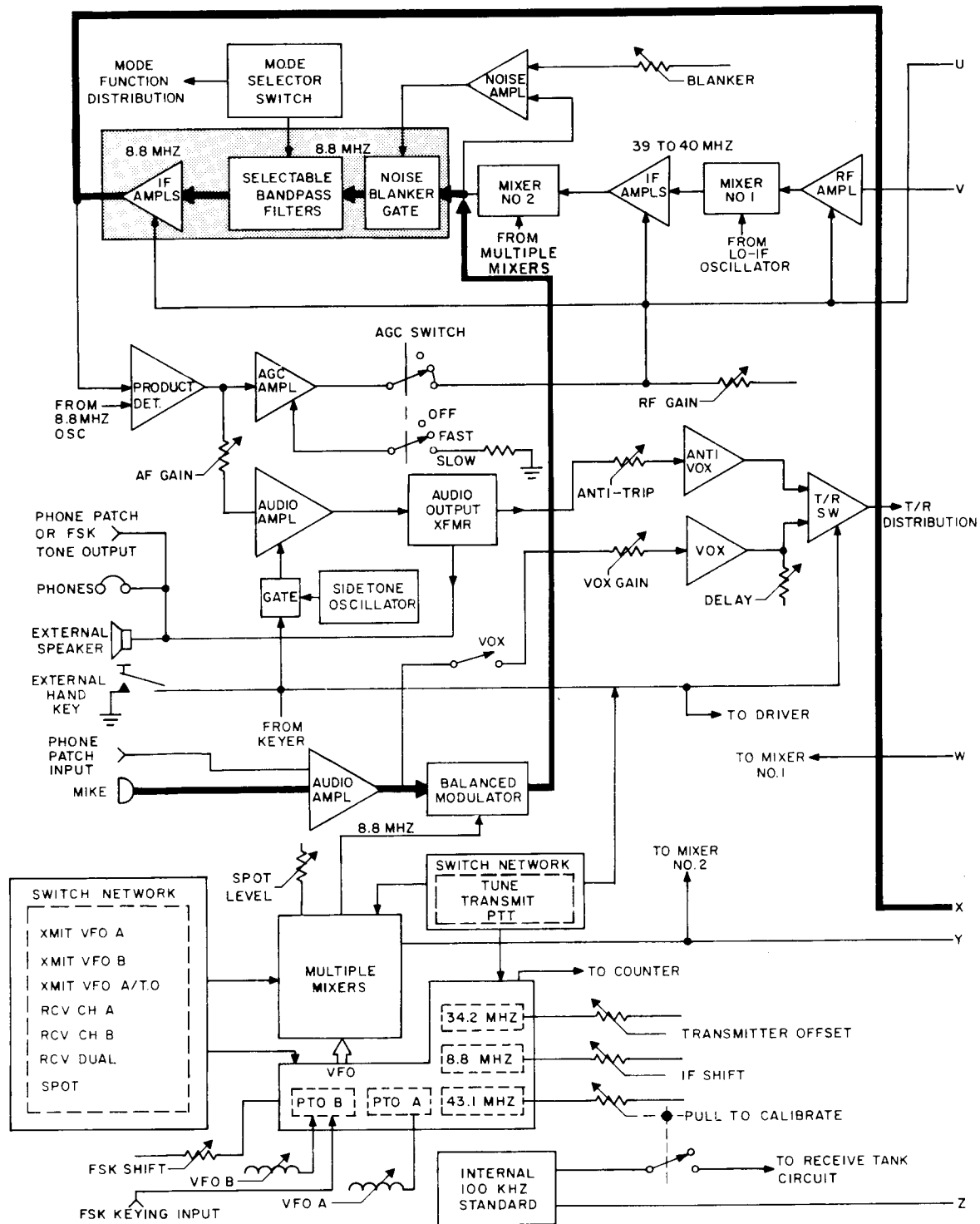
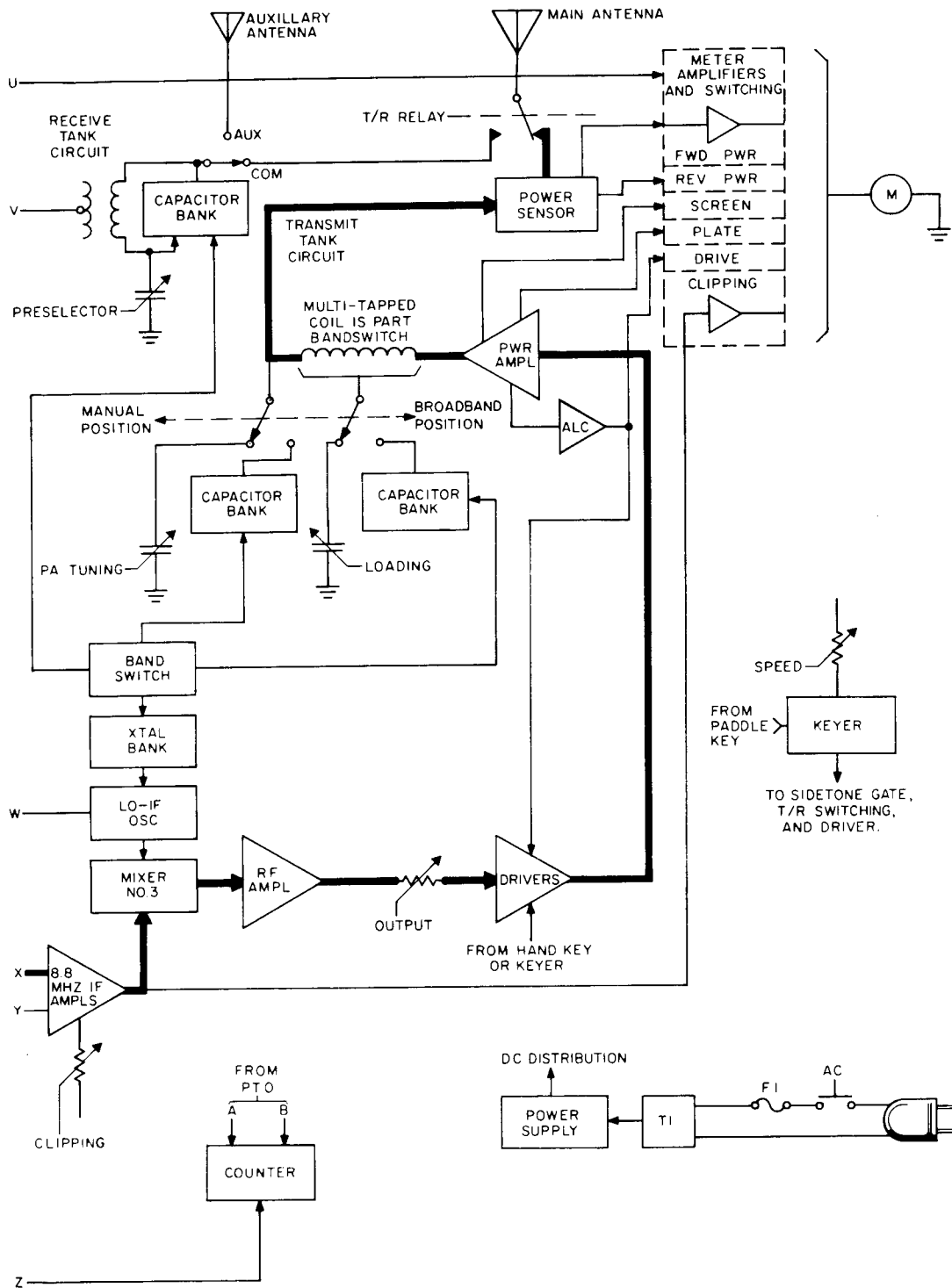

Figure 1-1. Model CX7 Deluxe Integrated Station



A Simplified Block Diagram of the Model CX7 is shown in Figure 1-2. While it is not the intent of this manual to cover the electronic theory of operation, the brief explanation that follows provides a basic concept that will aid in understanding the ensuing paragraphs: Stages that are common to both transmit and receive signal paths

are shaded. The most common transmit signal path is depicted by the heavy, dark line. Where practical, operating switches and controls are shown with their interfacing stage. Transmit/Receive (T/R) command signals are used to disable the operation of circuits that are not desired for a specific mode. The circuitry beyond the



output of mixer no.3 is broadband and operating at the actual transmit frequency. The receiver portion utilizes double conversion with 39 to 40 MHz and 8.8 MHz IF. Sideband, CW, and compatible AM demodulation is derived from the product detector. A VFO is comprised of a permeability tuned oscillator (PTO) and a 34.2 MHz

oscillator. The scheme in which the VFO's and multiple mixers are utilized establishes the versatility of the Model CX7. Therefore, the majority of the switches and controls are centered around these stages. A detailed explanation of circuits is covered in the Model CX7 Deluxe Integrated Station Service Manual.

1.2 SPECIFICATIONS

1.2.1 General

a. Frequency Coverage. All amateur bands 1.8 to 30.0 MHz in full 1 MHz ranges. An additional 1 MHz band may be added in each of the three ranges, 2.0 to 3.0, 4.0 to 7.0, and 8.0 to 14.0 MHz, by installing appropriate crystals.

b. VFO's. Two identical, permeability-tuned precision oscillators; 1 MHz tuning range with nominal 25 kHz per knob revolution.

c. Readout. Accuracy, linearity, and reset-ability to 100 Hz at any point in any band after calibration at any 100 kHz checkpoint in that band. Integrated circuit digital frequency counter with miniature, high-intensity long-life Nixie display instantly shows actual frequency being received or transmitted.

d. Spotting. Push button provides audio beat note for spotting when using separate VFO's or Transmit Offset/Transceive Mode.

e. T/R Switching. Push-to-talk or fast-attack VOX; instantaneous break-in CW; fast key-up receiver recovery independent of AGC decay. Isolated terminals for control of external amplifier.

f. CW Keyer. Built-in electronic keyer, 5 to 60 wpm. Separate jacks for keyer paddle and manual key.

g. Frequency Control Modes. Transceive with either VFO, "split" using both VFO's, transceive on either VFO plus independent receive-only on the other, or "Transmit Offset" transceive (transmit frequency tracks receiver and may be instantly offset up to plus or minus 3 kHz from receive frequency).

h. Emission Modes. SSB, CW, FSK, compatible AM.

i. Power Supply. Built-in heavy-duty supply for 115/230 volts, 50 to 400 Hz. Sillectron transformer for exceptional regulation and power with very small size and weight. Requires approximately 100 watts receive, 400 watts peak at full input.

j. Construction. All critical circuitry (except P.A. and large power supply components) is modular on glass epoxy etched circuit boards.

k. Size and Weight. 16-1/4"W, x 7-1/4"H, x 14" deep overall, less feet. 35 pounds.

1.2.2 Receiving System

a. Active Devices. 16 digital integrated circuits, 14 linear integrated circuits, 100 transistors (both bipolar and MOS FET) one ceramic metal P.A. tube.

b. Sensitivity. Better than 10 db signal-plus-noise-to-noise ratio for 1/3 microvolt input at 10 meters (2 kHz bandwidth).

c. Selectivity. Standard (SSB) - 2 kHz at -6 db, 1.5:1 (6:60 db) shape factor (two cascaded 8-crystal lattice filters). Optional: 1. Standard CW - 400 Hz with 4:1 shape factor; 2. Deluxe CW - 300 Hz with 2:1 shape factor; 3. Standard FSK - 1200 Hz with 2:1 shape factor (internal sockets provided for two optional filters).

d. Ultimate Attenuation. More than 60 db.

e. Image and IF Rejection. More than 60 db.

f. Internal Spurs. Less than 1 μ v equivalent. (Except at 1.912 MHz.)

g. AGC. Fast attack with selectable 10 ms decay or 300 ms hang time; less than 6 db audio output change for signal level from 1 μ v to 100 mv.

h. Front End Dynamic Range. A 10 microvolt desired signal will be modulated less than 10% by an unwanted 10,000 μ v signal 10 kHz away modulated 30% at 400 Hz, or by a similar 100,000 μ v signal 5% removed in frequency.

i. Audio Output. 1 watt.

j. IF Shift. Second IF adjustable up to plus or minus 2 kHz with respect to IF filter passband for interference rejection and receiver audio passband selection. Tracking error, zero.

k. Dual Receive. Two channels usable separately or simultaneously; continuously variable relative RF gain control. Either channel may be used for transceiving and the other for receive-only.

l. Noise Blanker. Pre-IF blanker with adjustable threshold.

1.2.3 Transmitting System

a. Tuning. Pretuned bandpass output filter requires no adjustment when feeding nominal 50-ohm resistive load in amateur bands; manual tuning and loading for out-of-band or high SWR operation. Driver broadband 1.8 to 30.0 MHz.

b. Power Amplifier. Solid-state, completely broad-band driver; rugged, ceramic-metal 8072 tetrode final amplifier conduction-coupled to massive extruded heat sink. 150 watts continuous dissipation rating at 25°C ambient.

c. Power Level. Nominal 300 watts PEP input, 150 watts PEP output all bands and modes below 28 MHz (130 watts above 28 MHz). Output continuously adjustable down to less than 1 watt.

d. Duty Cycle. Continuous at rated PEP input all modes.

e. Carrier and Unwanted Sideband Suppression. 60 db.

f. Distortion. Third-order intermodulation products more than 30 db below each of two equal tones at full rated output.

g. Speech Processing. RF envelope clipper plus cascaded 8 pole crystal filters in SSB and compatible AM (USB with carrier) modes. Clipping adjustable 0 to 20 db nominal.

h. Metering. Clipping, drive level, plate and screen currents, forward and reflected RF power.

1.3 RECOMMENDED ACCESSORIES

a. Speaker. Only use the Signal/One Model CX7S speaker or one having the following characteristics:

1. Typical Size: 6 x 9 inches
2. Voice Coil: 3.2-ohm impedance
3. Magnet: 3.2-ounce Alnico V
4. Typical Rating: 8 watts
5. Frequency Range: 60 to 10,000 Hz or better.

b. Headphones

1. Impedance: Low
2. Frequency Range: 60 to 10,000 Hz or better.

c. Microphone. Only use the Signal/One Model CX7M microphone or one having the following characteristics:

1. Output Level: -57 db or better
2. Response: 60 to 10,000 kHz, or better

3. Impedance: High

4. Switching: With or without push-to-talk function.

d. Antenna. The Model CX7 is a deluxe integrated station of exceptional performance. It is designed for use with an antenna having an input impedance of 50 ohms. The use of random length wire antennas will degrade performance unless a good antenna coupler, with a 50-ohm output, is used. Do not use an antenna having a S.W.R. of more than 3:1.

1.4 OPTIONAL FILTERS AND CRYSTALS

The following optional filters and crystals may be purchased directly from Signal/One or Model CX7 distributors and can easily be installed by the Model CX7 owner following simple instructions supplied with the parts.

a. Standard CW Filter: 400 Hz bandpass

b. Deluxe CW Filter: 300 Hz bandpass

c. Standard FSK Filter: 1200 Hz bandpass

d. "A" Frequency Crystal: Provides capability to operate between 2.0 and 3.0 MHz frequency.

e. "B" Frequency Crystal: Provides the capability to operate in either the 4.0 to 5.0, 5.0 to 6.0 MHz, or 6.0 to 7.0 MHz frequency range. (Specify which range when ordering.)

f. "C" Frequency Crystal. Provides the capability to operate in either the 8.0 to 9.0, 9.0 to 10.0, 10.0 to 11.0, 11.0 to 12.0, 12.0 to 13.0, or 13.0 to 14.0 MHz frequency range. (Specify which range when ordering.)

1.5 PREPARATION FOR USE

1.5.1 Unpacking. Carefully lift the transceiver out of the packing material and examine it for visible damage. If the transceiver has been damaged in shipment, save the box and packing material, and notify the transportation company. Check the tuning controls and switches for freedom of action. Be sure to remove the accessory jumper plug and the power cord and plug from the packing material also. Fill out and mail the warranty registration card.

1.5.2 Normal Operation Interconnections

a. Connect the accessory plug and power plug, with cord, to the applicable rear panel connector.

NOTE

The supplied accessory plug must be connected at all times because it contains jumper wires vital for the operation of the Model CX7. Do not connect the power plug to an ac outlet until the operating instructions have been reviewed. For the remaining connections, only use the type of accessories that possess the recommended electrical characteristics. Refer to Table 1-1 for the required type of mating plugs.

b. Perform either of the following:

1. Connect the headphones to the front panel "PHONES" jack.

2. Connect the loudspeaker to the rear panel "SPKR" connector.

c. Perform one of the following:

1. Connect the microphone to the front panel "MIKE" jack.

2. Connect the hand telegraph key to the rear panel "EXT KEY" jack.

3. Connect the paddle key to the rear panel "KEYER" jack.

d. Connect the main antenna utilized for both transmitting and receiving to the "ANTENNA" connector located immediately below the rear panel threaded bolt and wing nut terminal.

e. Connect an earth ground to the rear panel threaded bolt and wing nut terminal.

f. If it is desired to utilize an auxiliary antenna for only receiving (in addition to the main antenna), connect that antenna to the "RCVR" connector to the immediate left of the rear panel threaded stud and wing nut terminal.

1.5.3 Special Purpose Interconnections



Accomplish the following interconnections with the Model CX7 power cord disconnected from an ac outlet.

1.5.3.1 Phone Patch Operation

a. Connect the headphones or speaker, microphone, antenna and earth ground as described in paragraph 1.5.2.

b. Connect the phone patch transmit lines to the rear panel "PATCH" connector.

c. Connect the phone patch receive lines to the rear panel "POWER" plug audio output pins 4 and 5.

1.5.3.2 FSK

a. Connect the antenna and earth ground as described in paragraph 1.5.2.

b. Connect a common ground between the rear panel earth ground stud and all the applicable external equipment.

c. Connect the teletypewriter transmit lines as follows:

1. Connect one of the wires to any convenient common ground point, such as, the rear panel earth ground stud or the teletypewriter frame.

2. Connect the remaining transmit line to the Model CX7 rear panel "POWER" plug pin 9.

d. Connect the receive lines from an external FSK tone converter to the Model CX7 rear panel "POWER" plug audio output pins 4 and 5.

e. Perform the remaining interconnections as recommended by the manufacturer of the FSK tone converter being utilized.

1.5.3.3 Linear Amplifier

a. Connect the microphone or telegraph key, speaker or headphones, and earth ground as described in paragraph 1.5.2.

b. Connect a common ground between the rear panel earth ground stud and the linear amplifier.

c. Connect a coaxial cable between the rear panel main antenna connector and the linear amplifier RF input.

d. Connect a cable between the rear panel "RLY" connector and the linear amplifier key-line input. (A ground will be present whenever the Model CX7 is keyed for a transmit condition.)

e. Connect a cable between the rear panel "ALC" connector and the linear amplifier automatic load control output.

f. Perform the remaining interconnections as recommended by the manufacturer of the linear amplifier being utilized.

Connector	Type of Plug
PHONES	Switchcraft No. 255
MIKE	Military Type PJ-068
EXT KEY	Switchcraft No. 255
KEYER	Switchcraft No. 297
H. V.	E. F. Johnson No. 105-300
PATCH	RCA Standard Phono Type
HI-IF	RCA Standard Phono Type
LO-IF	RCA Standard Phono Type
L. O.	RCA Standard Phono Type
SPKR	RCA Standard Phono Type
RLY	RCA Standard Phono Type
RCVR	RCA Standard Phono Type
J19	RCA Standard Phono Type
ALC	RCA Standard Phono Type
ANTENNA	Military Type PL-259

Table 1-1. Required Type of Mating Plugs

SECTION II

OPERATING INSTRUCTIONS

2.1 GENERAL

To effectively use the Model CX7, the operation and capabilities of the deluxe integrated station must be known. This section describes the operation of front and rear panel controls and connectors and gives first time and general operating information. Do not attempt operation until this section has been completely reviewed and understood.

2.1.1 Operating Position. The operating position should be such that the heat radiation from the rear panel heat sink may rise in a direction away from the internal circuitry. The recommended operating position is to set the Model CX7 in a feet-down position or with the front end slightly elevated utilizing the bottom tilt-stand.

2.1.2 Operating Voltage. The Model CX7 was designed to be operated from either a 115 volt or 230 volt nominal voltage in accordance with specific power supply jumper wire connections. Unless otherwise requested by the purchaser, the Model CX7 is factory-wired for 115-volt operation.

2.1.3 Operating Temperature. The Model CX7 is cooled, without the use of internal blowers, by thermal conduction. The rear panel heat sink and thermal cut-outs on the cover should not be obstructed in a manner that would restrict radiating heat to escape. The clearance provided by the bottom feet should be maintained. If possible, allow one inch of clearance on the top and sides and at least four inches in the rear. Continuous operation can be maintained at ambient air temperatures between +32°F and +122°F. At temperatures exceeding +80°F, it is recommended that air flow from a blower or fan be directed on the rear panel heat sink. The unit can be stored at ambient temperatures between -58°F and +122°F. After storage at temperatures beyond the operating limits, allow the chassis temperature to come within the operating limits before power is applied.

2.2 Controls, Connectors, and Indicators. Front or rear panel controls, connectors, and indicators used in operating the Model CX7 are shown

in Figures 2-1 and 2-2 and described in Table 2-1. The descriptions given in the table are not intended to be operating instructions, but only a reference to determine the function of each item. The actual operating procedures are covered in paragraphs 2.3 through 2.4.6.

2.3 Receive Mode Operating Procedures

2.3.1 General. The following general instructions covered in paragraph 2.3.1a through g are stated for information purposes and should not be performed at this time. It is important that the operator be cognizant of these and other conditions covered herein before performing the actual turn-on specified in paragraph 2.3.2g. The basic steps for establishing the transmit mode are included so that the operator is aware of how to prevent accidentally keying the transmitter.

a. **Establishing a Transmit Mode.** The transmit mode is defined as enabling the operation of all the transmitter circuits. This is sometimes referred to "keying the transmitter". Power output may or may not be present, consequently either a dummy load or an antenna should always be connected to the rear panel main antenna connector. The transmit mode can be established by remote command signals (a ground) from a microphone or telegraph key or by proper positioning of the front panel switches. Therefore, any of the following operations will establish a transmit mode:

1. Setting the "PUSH-TO-TALK" switch on the microphone to the "ON" or "TALK" position.
2. Depressing the telegraph key.
3. Depressing the front panel control "VOX" switch to the latched-in position and speaking into the microphone.
4. Depressing the front panel control "TRANSMIT" switch to the latched-in position.
5. Depressing the front panel control "TUNE" switch to the latched-in position.

b. Establishing a Receive Mode. The receive mode is defined as switching the Model CX7 out of the transmit mode and enabling the operation of all the receiver circuits. Like the transmit mode, the receive mode can also be established by remote keying command signals (switching from a ground to a constant open) and properly positioning a front panel switch. Unlike the transmit mode that could be established by performing any one of the five operations listed in paragraph a, the receive mode can only be established after all the following operations have been completed:

1. Positioning the "PUSH-TO-TALK" switch on the microphone to the "OFF" or "LISTEN" position (when the "VOX" switch latched-in).

2. Permitting the telegraph key to remain in the open circuit condition.

3. Depressing the front panel control "PTT" or "VOX" switch to the latched-in position which causes the "TRANSMIT" or "TUNE" switch to eject to the extended (out or off) position.

c. Energizing (Turning ON) or Deenergizing (Turning OFF) the Model CX7.

It is good standard practice never to energize or deenergize the Model CX7 when it is keyed in a transmit mode. First, always establish the receive mode. The Model CX7 is deenergized when the front panel control "AC" switch is in the extended (out or off) position. The Model CX7 may be energized by simply depressing the "AC" switch to the latched-in position or deenergized by depressing the switch until it bottoms and then permitting it to release to the extended position. The Nixie tube "KHZ" display will illuminate whenever the Model CX7 is energized. In addition to indicating the bandspread setting, their illumination serves as a visual confidence indication of an energized Model CX7 condition.

d. Operation of Front Panel Push-Switches. The front panel push-switches for "METER", "TRANSMIT VFO", and "CONTROL" functions operate in a similar manner as the "AC" switch previously explained. However, they are deenergized using a different method. Other than the "SPOT" pushbutton or "AC" push-switch,

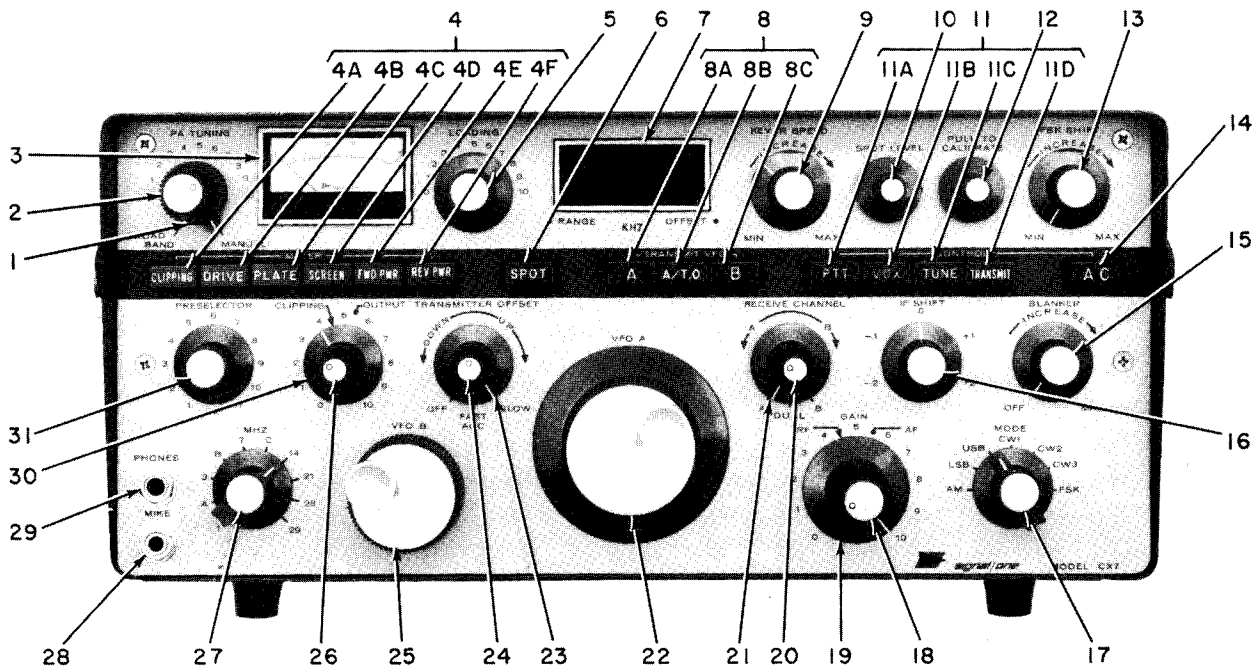

Figure 2-1. Model CX7 Front View

only one push-switch per group should be energized at a time. The energized position can also be referred to as the "DEPRESSED", "LATCHED-IN", "IN", "ON", or "SELECTED" position. Likewise, the deenergized position can also be referred to as the "OUT", "EXTENDED", or "RESET" position. To select the function listed on the applicable push-switch, depress the switch to the latched-in position.

CAUTION

Never simultaneously depress two or more of the grouped push-switches as each will latch-in resulting in many abnormal operating conditions.

To deenergize one of these grouped push-switches, simply depress one of the switches having an associated function. For example, if it is desired to deenergize the "TRANSMIT VFO-A" switch, depress either the "TRANSMIT VFO-B" or "A/T.O." push-switches. It should be noted that if a deenergized switch is not completely depressed, it may reset an energized switch, but may not seat itself to the latched-in position. This is recognizable by all the push-switches in

an associated group being in the same extended position. This presents an abnormal operating condition resulting in various symptoms such as an improper meter indication or no power output. This may cause operator confusion so it is recommended that when meter or transmit VFO functions are not in use, the "PLATE" meter and the "A" transmit VFO switches be kept energized.

e. Operation of the Frequency Display and Normal Bandsread Tuning. The tuning position of the applicable "VFO-A" or "VFO-B" control within the bandsread is determined by observing the combined presentation for the four Nixie tubes. These tubes are always illuminated whenever the "AC" switch is energized. There is no mechanical linkage or gearing connecting the VFO control to the frequency display, consequently, what is being viewed is the output result of the electronic counter computer circuitry that analyzed the bandsread portion of the VFO output. It is perfectly normal for the right-hand tube to alternately display a numeral one digit higher or lower at a visibly blinking rate. For example, it may be alternately indicating between 9 and 0, 0 and 1, 1 and 2, 2 and 3, etc. When this occurs, it should be interpreted that it is 9-1/2, 1/2, 1-1/2, or 2-1/2, respectively. The display of the remaining tubes should be fixed, that is not

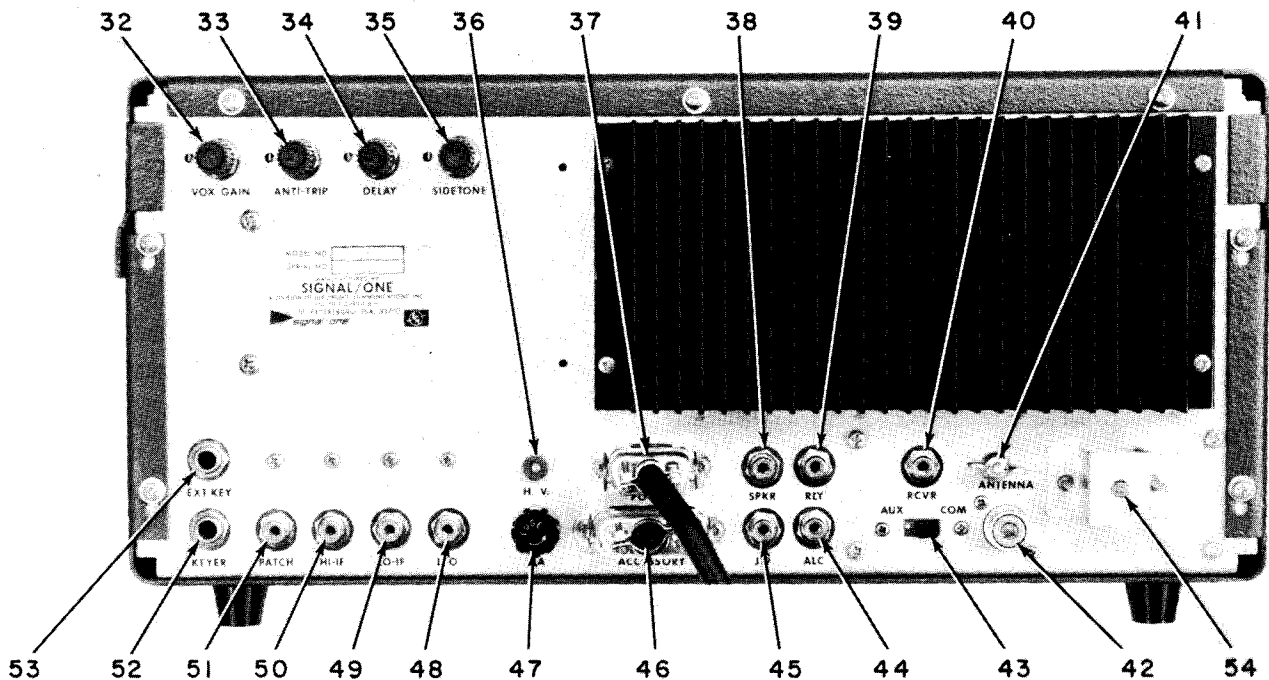

Figure 2-2. Model CX7 Rear View

changing if the VFO control is stationary. However, when the VFO is set to a frequency very near an even increment of ten, it is perfectly normal for two or more of the tubes to alternately display as previously described for the right-hand tube. Likewise, it may also appear that two of these digits are illuminated within the same tube. In this case, the display should change to a fixed indication when the applicable VFO control is rotated a few more degrees in either direction. There is approximately 50 complete 360° rotations of each VFO control from the full counterclockwise end to the full clockwise end. The end points of the "VFO A" and "VFO B" are noticeable by the start of a gradual increase in mechanical resistance of rotation and it should not be forced beyond this point for obvious reasons. Approximately between one half and two rotations from the full counterclockwise end is the beginning of the one megahertz bandspread and the frequency that should be displayed is "000.0". At this point, rotation to the left causes the over-range decimal point to illuminate and the display changes to ".999.9" or less depending on the final VFO control setting. If the "MHZ" band selector was set to "3", the display indication of ".999.9" would represent either a transmit or receive frequency of 2.999,900 MHz and a "000.0" indication would represent a frequency of 3.000,000 MHz. When the applicable VFO control is rotated to the right, the frequency increases approximately 25 kHz per revolution until the high end of the band is signified by a "999.9" frequency display. Further rotation to the right causes the over-range decimal point to again illuminate and the display changes to ".000.0" or greater, depending on the final VFO control setting. If the "MHZ" band selector was set to "3", the display indication of ".000.1" would represent a final frequency of 4.000,100 MHz. Each VFO is capable of being tuned approximately 25 kHz beyond the high (an indication of ".025.0") or low end (an indication of ".975.0") band edges. Therefore, caution must be used in VFO tuning in the transmit mode to prevent out of band transmission. It should always be remembered that the frequency being displayed is only the bandspread frequency and not the actual final receive, transmit, or entire VFO frequency. Therefore, the calibration procedure covered in paragraph 2.3.4 should periodically be performed. Changing the setting of the front panel "CALIBRATE", "TRANSMITTER OFFSET", or "IF SHIFT" control does not and was not intended to change the bandspread indication or bandspread spectrum. Whenever the transmit VFO "A/T.O." switch is latched-in, the "OFFSET" decimal point, on the right-hand side of the fourth

Nixie tube from the left, illuminates. For example, if the display is indicating "345.6" (345.6 kHz) and then the "A/T.O." switch is depressed, the display changes to "345.6." (345.6 kHz). When reading the display, disregard the illumination of the "OFFSET" decimal point as its only purpose is to provide a visual reminder that the Model CX7 is in the transmit offset mode. If there is any doubt as to which VFO is being displayed, the question can be resolved by applying the following rules:

1. In the transmit mode, the display will indicate the VFO marked on the "TRANSMIT VFO" switch that is set to the latched-in position. (If the "A/T.O." switch is latched-in, VFO A is indicated.) If all three of these switches are in the out position, VFO A will be displayed.

2. In the receive mode, the display will indicate the VFO marked on the setting of the "RECEIVE CHANNEL" rotary selector switch (outer concentric control) except when in the "DUAL" position it will be VFO A.

- f. Receive Mode Metering Indications. The front panel meter functions as an "S" meter regardless of the position of the "METER" switches, however, when the "SCREEN" switch is latched-in, the meter indicates slightly less than zero. Therefore, signal strength is usually measured with the "PLATE" switch latched-in. The meter has two scales. The red scale is used for "S" units 0 through 60. The black scale is used for transmitter mode indications. The "S" meter will move with the adjustment of the "RF GAIN" control, but will still indicate correctly with the rf gain set at less than maximum (if the received signal level is high enough to register on the "S" meter). For example, if the "RF GAIN" control is set for a no-signal meter indication of S-5, and the meter registers S-9 with a signal, then the receive signal is S-9. An S-9 indication is equivalent to a 50 microvolt signal at the main antenna connector.

- g. Preexisting Switch and Control Positioning. As a convenience for the new CX7 owner, Signal/One positions all the switches and controls to specific settings prior to shipment. The positions were selected to help reduce initial operating errors and are listed in Table 2-2. The positioning sequence of each switch and control is repeated in detail in the following procedures for the benefit of those operating the Model CX7 for the first time.

Index No.	Item	Description
1	"BROADBAND/MANUAL" switch	<p>The outer concentric two position rotary switch used in the transmit mode to select plate tank circuit capacitors. When the switch is set to "BROADBAND" no additional plate tank tuning is required after the desired band is selected.</p> <div style="border: 2px solid black; padding: 5px; text-align: center; margin: 10px 0;">WARNING</div> <p>Do not change positions of the "BROADBAND/MANUAL" switch when the Model CX7 is keyed for a transmit condition, as this will result in damage to equipment, which is not covered by the warrantee.</p>
2	"PA TUNING" control	<p>The inner concentric continuous turn control used in the transmit mode to manually adjust the input capacitance in the plate tank. A "0" setting is maximum capacitance and "10" is minimum. Prior to effectively operating this control, the "BROADBAND/MANUAL" switch (Index No.1) must be first positioned to "MANUAL."</p>
3	Meter	<p>The meter indication is dependent upon which "METER" switch is depressed. When in the transmit mode, the top scale "0" through "5" is used for a reference indication. The bottom scale "0" through "60" indicates received signal strength when in the receive mode regardless of "METER" switch position.</p>
4	"METER" switches	<p>The "METER" switches are used to select the desired parameter to be measured. The proper switch must be depressed (energized or the "IN" position). For the meter to indicate the desired transmit function, the six two-position meter switches are mechanically interconnected so that only one may be depressed at any one time. The switch is deenergized when in the extended (OUT) position. To place all "METER" switches in the deenergized position, simply depress any deenergized meter switch half way in and allow it to return to the extended position.</p>
4a	"CLIPPING" switch	<p>When depressed, permits the meter to indicate the relative transmit signal level in the 8.8 MHz IF stage as determined by the "CLIPPING" control (Index No. 30). A deflection of S-3 during voice peaks represents 10 db of clipping and</p>

Table 2-1. Controls, Connectors, and Indicators (Sheet 1 of 9)

Index No.	Item	Description
4a (Cont)		full scale deflection during voice peaks is equivalent to 20 db of clipping.
4b	"DRIVE" switch	When depressed, permits the meter to indicate the relative automatic level control (ALC) signal bias for the RF Driver board. A midscale deflection is equivalent to approximately 6 db of ALC action.
4c	"PLATE" switch	When depressed, permits the meter to indicate the relative plate current drawn from the high voltage rectifier circuit on the Power Supply board. A full scale deflection is equivalent to 500 ma.
4d	"SCREEN" switch	When depressed, permits the meter to indicate the relative screen current drawn from the +300 Vdc rectifier circuit on the Power Supply board. A full scale deflection is equivalent to 50 ma.
4e	"FWD PWR" switch	When depressed, permits the meter to indicate the relative power output being applied to the rear panel antenna connector. A full scale deflection is equivalent to 200 watts. (See conversion Table 2-4).
4f	"REV PWR" switch	When depressed, permits the meter to indicate the relative power reflected from the rear panel antenna connector to the plate tank circuit. A full scale deflection is equivalent to 200 watts. (See conversion Table 2-4).
5	"LOADING"	A control used in the transmit mode to manually adjust capacitance within the plate tank. It is adjustable for any setting on or between "0" and "10." A "0" setting is maximum capacitance and "10" is minimum. Prior to effectively operating this control, the "BROADBAND/MANUAL" switch (Index No.1) must be first positioned to "MANUAL."
6	"SPOT" pushbutton	A pushbutton switch that enables the operation of a mixer stage located on the IF board when manually held in the depressed position. The pushbutton automatically returns to the de-energized position when released. When depressed, a tone is present if the transmit and receive frequency are within 3 kHz of each other.
7	"KHZ" display	A four tube numeric readout, that is representative of bandsread tuning. Either channel A or B tuning may be displayed depending upon the setting of the "TRANSMIT VFO" switches

Table 2-1. Controls, Connectors, and Indicators (Sheet 2 of 9)

Index No.	Item	Description
7 (Cont)		(Index No. 8a, b, c), "SPOT" pushbutton (Index No. 6), and "RECEIVE CHANNEL" switch (Index No. 21). The decimal point on the third tube from the left is permanently displayed. The decimal point on the fourth tube from the left is displayed whenever the "TRANSMIT VFO-A/T. O." switch (Index No. 8b) is depressed. The decimal point on the first tube on the left is automatically displayed whenever the counter is operating in an overrange condition.
8	"TRANSMIT VFO" switches	The "TRANSMIT VFO" switches are used to select the desired VFO for a transmit condition. If the Model CX7 is not keyed for a transmit condition, VFO selection is determined by the "RECEIVE CHANNEL" switch (Index No. 21). The three switches are mechanically interconnected and only one should be depressed at any one time. In order to transmit, one of these switches must be energized at all times. Failure to do so will result in no rf drive to stimulate power output.
8a	"A" switch	When depressed, selects VFO A to be transmitted.
8b	"A/T. O." switch	When depressed, selects VFO A to be transmitted at a frequency which can be slightly offset from the normal VFO A frequency. The amount of offset is determined by the "TRANSMITTER OFFSET" control (Index No. 24).
8c	"B" switch	When depressed, selects VFO B to be transmitted.
9	"KEYER SPEED" control	A potentiometer that varies the frequency of oscillator in the electronic keyer thereby changing the transmitted speed of the dot or dash cw output. The rate of speed is approximately 5 WPM when positioned to "MIN" and 60 WPM when positioned to "MAX".
10	"SPOT LEVEL" control	A potentiometer that varies the attenuation of the audio output produced when the "SPOT" pushbutton (Index No. 6) was depressed.
11	"CONTROL" switches	These four two-position "CONTROL" switches are used to select specific type of modes. Only one switch should be depressed (energized or the "IN" position) at any one time. Each switch is deenergized when in the extended (OUT) position.

Table 2-1. Controls, Connectors, and Indicators (Sheet 3 of 9)

Index No.	Item	Description
11a	"PTT" switch	When depressed, this switch only serves the mechanical function of resetting the associated switches (Index No. 11b, 11c, and 11d) to the deenergized position thereby placing the Model CX7 in the receive mode.
11b	"VOX" switch	When depressed, the VOX mode is established and the presence of voice signals will automatically enable the operation of the transmitter circuits. The absence of voice signals will cause automatic switching to the receive mode. The function of this switch is dependent upon the setting of the "VOX GAIN" control (Index No. 32) and the "ANTI-TRIP" control (Index No. 33).
11c	"TUNE" switch	When depressed, it enables the operation of the transmitter circuits and causes an internal CW signal to drive the PA stage resulting in power output. This permits manual power amplifier tuning or internal adjustments to be performed under test conditions.
11d	"TRANSMIT" switch	When depressed, it enables the operation of the transmitter circuits. Power output will not be developed until a CW or modulating signal is supplied from an external source.
12	"PULL TO CALIBRATE" control	A switch/potentiometer assembly that applies the output of the 100 kHz standard to the receiver front end when in the pulled out position. When this control is rotated it changes the frequency of the 43.1 MHz oscillator on the BFO board.
13	"FSK SHIFT" control	A potentiometer that changes one of the local oscillator frequencies used in generating VFO B when the appropriate rear panel interconnections have been wired.
14	"AC" switch	A two position switch that applies ac power to the Model CX7 when depressed to the "IN" position. Power may be removed by further depressing the switch until it releases and positions to the extended (OUT) setting. This switch also supplies an open or a ground to the rear panel power connector (Index No. 37) for external logic switching purposes.
15	"BLANKER" control	A potentiometer that changes the threshold of the noise blanker amplifier. The noise blanker circuit does not function when in a transmit

Table 2-1. Controls, Connectors, and Indicators (Sheet 4 of 9)

Index No.	Item	Description
15 (Cont)		mode or when the control is set to "OFF". Increasing the control to the appropriate setting cancels rf noise pulses in the receive signal path.
16	"IF SHIFT" control	A potentiometer that is used in the receive mode to change the frequency of the 8.8 MHz oscillator on the BFO board. Its function permits an interfering signal to be shifted out of passband of the IF filters. At the "0" position, the IF frequency is centered in the IF filter passband. The numerical settings of "-2", "-1", "+1", and "+2", represent the frequency in kHz from the center of the IF filter passband. This control does not affect the local oscillator frequency in the transmit mode.
17	"MODE" selector	A seven position rotary switch that determines the operating mode for reception and transmission. The "AM" (amplitude modulation), "LSB" (lower sideband), "USB" (upper sideband), and "CW1" (continuous wave number one) positions select standard functions. The "CW2" (continuous wave number two), "CW3" (continuous wave number three), and "FSK" (frequency shift keying) positions select special functions and will result in no output unless optional filters are installed. The receive signal characteristics which result from the "AM", "USB", and "CW1" positions are effectively the same quality. Likewise, the "LSB" signal is similar except that it is the lower sideband. The signal characteristics for the remaining positions are dependent upon the passband of the optional filters.
18	"GAIN-AF" control	The inner concentric control is a potentiometer that varies the attenuation of the product detector audio output. It is an independent portion of a dual-potentiometer assembly. The other independent portion is the "GAIN-RF" control (Index No. 19).
19	"GAIN-RF" control	The outer concentric control is a potentiometer that varies the operating bias of the Front End and IF board RF stages.
20	"RECEIVE CHANNEL" balance control	The inner concentric control is a potentiometer that varies the operating bias of the "A" and "B" mixers on the IF board, when in the receive mode. It is a portion of a potentiometer/switch assembly. The effect of its operation is dependent upon the setting of the switch portion

Table 2-1. Controls, Connectors, and Indicators (Sheet 5 of 9)

Index No.	Item	Description
20 (Cont)		(Index No. 21) which must be set to "DUAL". When set to the midrange position, the output of both mixers will be the same level. When positioned toward either the "A" or "B" settings, the applicable mixer output will be higher or lower in level.
21	"RECEIVE CHANNEL" balance control	The outer concentric control is a three position rotary switch. The "A" position permits only the VFO A operation, the "B" position permits only the VFO B operation and the "DUAL" position permits the operation of both. The switch functions are only applicable in the receive mode and do not interfere with or determine the selection of the transmit VFO.
22	"VFO A" control	A control that permits tuning an inductor located in VFO A. Its movement covers the 1 MHz bandspread range with approximately 25 kHz change per revolution. The exact position in the band, to within 100 Hz, is indicated on the Nixie tube display (Index No. 7) depending on the specific setting of the "TRANSMIT VFO" switches (Index No. 8) or the "RECEIVE CHANNEL" switch (Index No. 21).
23	"AGC" switch	A three position rotary switch that determines the operation of the automatic gain control (AGC) circuit used in the receive mode. The "OFF" position opens the AGC output signal path and the remaining two positions complete the signal path. The "FAST" position selects a fast time constant AGC voltage decay and the "SLOW" position selects a slow "HANG" time constant AGC voltage decay.
24	"TRANSMITTER OFFSET" control	The inner concentric control is a potentiometer that permits the offset oscillator frequency to be varied. It must be used in conjunction with the "TRANSMIT VFO-A/T.O." switch (Index No. 8b). The midrange position is the center frequency. Rotation from midrange to the left permits the VFO A frequency to be decreased proportionally to a maximum of -3 kHz. Rotation from midrange to the right permits the VFO A frequency to be increased proportionally to a maximum of +3 kHz.
25	"VFO B" control	A control that permits tuning an inductor located in VFO B. It performs a similar function as previously explained for the "VFO A" control (Index No. 22).

Table 2-1. Controls, Connectors, and Indicators (Sheet 6 of 9)

Index No.	Item	Description
26	"OUTPUT" control	The inner concentric control is an independent portion of a dual potentiometer assembly. It is used in the transmit mode to vary the attenuation of the excitation input to the RF Driver board thereby controlling the amount of RF power output. The "0" setting is representative of minimum drive and "10" is maximum.
27	"MHZ" band selector	<p>A ten position rotary selector switch used to select the desired frequency band. The "A", "B", or "C" positions will result in no output unless optional crystals have been installed for nonamateur band use. The remaining positions represent the specific low end frequency of the selected band.</p> <div data-bbox="1050 737 1321 831" style="border: 2px solid black; padding: 5px; text-align: center; margin: 10px auto; width: fit-content;"> <p>WARNING</p> </div> <p>Do not change positions of the "MHZ" band selector when the Model CX7 is keyed for a transmit condition, as this will result in damage to the equipment, which is not covered by the warrantee.</p>
28	"MIKE" connector	A jack connector that permits a high impedance microphone audio output and push-to-talk lines to be applied to the Model CX7.
29	"PHONES" connector	A jack connector that permits low impedance headphone connections to the Model CX7. When the headphone plug is inserted, the speaker is disconnected from the circuit.
30	"CLIPPING" control	The outer concentric control is an independent portion of a dual potentiometer assembly that varies the operating bias of an IF amplifier stage in the transmit signal path. The "0" setting is representative of minimum clipping and "10" is maximum. This control is used in conjunction with the "CLIPPING" meter switch (Index No. 4 a).
31	"PRESELECTOR" control	A control used in the receive mode to adjust capacitance in the rf input tuned circuit. Its only function is to trim the front end after changing bands. The "1" setting represents minimum capacitance and "12" represents maximum.

Table 2-1. Controls, Connectors, and Indicators (Sheet 7 of 9)

Index No.	Item	Description
32	"VOX-GAIN" control	A potentiometer that varies the attenuation of the audio input being applied to the VOX amplifier circuit. Its function is to adjust the threshold level of speech that keys the Model CX7 for a transmit condition.
33	"ANTI-TRIP" control	A potentiometer that varies the attenuation of the speaker audio signal being applied to the anti-vox amplifier circuit input. Its function is to adjust the threshold level of demodulated audio that keeps the Model CX7 keyed for a receive condition.
34	"DELAY" control	A potentiometer that varies the resistance in a time constant circuit on the audio board. When using VOX keying in the transmit mode, its function is to adjust the length of time that the transmitter stays keyed after the operator stops speaking.
35	"SIDETONE" control	A potentiometer that varies the attenuation of the sidetone oscillator audio output when using CW emission in the transmit mode.
36	"HV" connector	A connector, with protective insert, providing a +1500 Vdc output for test and accessory use.
37	"POWER" connector	A connector providing multiple outputs and inputs for test and accessory use in addition to providing primary input power connections.
38	"SPKR" connector	A connector providing an audio output for external speaker use.
39	"RLY" connector	A connector providing a ground whenever the Model CX7 reed relay closes or the "TRANSMIT" switch (Index No. 11d) is energized. The output is for test and accessory use.
40	"RCVR" connector	A connector for applying an antenna to only the receiver input.
41	Ground connector	A threaded bolt with wing nut provided for earth ground connections.
42	"ANTENNA" connector	A connector for applying the main antenna to both transmitter output and receiver input.
43	"AUX-COM" switch	A two position slide switch for selecting the receiver antenna. The "COM" position connects the main "ANTENNA" connector (Index No. 42) to the receiver input. The "AUX" position connects the alternate "RCVR" connector (Index No. 40) to the receiver input.

Table 2-1. Controls, Connectors, and Indicators (Sheet 8 of 9)

Index No.	Item	Description
44	"ALC" connector	A connector providing an ALC output for test and accessory use.
45	"J19" connector	A spare connector.
46	"ACCESSORY" connector	A connector providing multiple outputs and inputs for test and accessory use.
47	"5A" fuse holder	A fuse holder for the 5A slow blow fuse in the primary power line.
48	"L. O." connector	A connector providing an output from the Front End board local oscillator for test and accessory use.
49	"LO-IF" connector	A connector providing an 8.8 MHz (25 kHz bandpass) output from the IF board for test and accessory use. The output level is dependent upon the setting of the "BLANKER" control (Index No.15).
50	"HI-IF" connector	A connector providing a 39 to 40 MHz bandpass output from the Front End board for test and accessory use.
51	"PATCH" connector	A connector for applying a phone patch transmit input to the Model CX7.
52	"KEYER" connector	A connector for applying the output of an external paddle key to the Model CX7.
53	"EXT KEY" connector	A connector for applying the output of an external telegraph key to Model CX7.
54	Bandswitch Shaft Extension	Bandswitch shaft extension permits the installation of an external one pole, 2 to 12 position ceramic wafer (Oak part no. 399150-JC), thereby, selecting different antennas or linear amplifiers by positioning the "MHz" band selector (Index No.27).

Table 2-1. Controls, Connectors, and Indicators (Sheet 9 of 9)

Control	Position
Broadband/Manual	*Manual
PA Tuning	6
Matching	6.5
Meter	Plate
PRESELECTOR	2
Clipping	3
Output	0
Transmitter Offset	*Center
AGC	Slow
Bandswitch	*3
Transmit VFO	A
Keyer Speed	Minimum
Spot Level	1/4 Range
Calibrator	*OFF (in)
FSK Shift	Minimum
Control	PTT
Receive Channel (outer control)	A
Receive Channel (inner control)	CCW
IF Shift	0
Blanker	OFF
RF Gain	10
AF Gain	3
Mode	USB
<u>Rear Panel</u>	
VOX Gain	1/2 Range
Anti-Trip	1/4 Range
Delay	CCW
Sidetone	1/4 Range

*See applicable WARNING or CAUTION note on following page.

Table 2-2. Switch and Control Positioning

WARNING

1. Never change positions of the "BROADBAND/MANUAL" switch when the Model CX7 is keyed for a transmit condition, as this will result in damage to the equipment which is not covered by the warranty.
2. Never change positions of the "MHZ" band selector switch when the Model CX7 is keyed for a transmit condition, as this will result in damage to the equipment, which is not covered by the warranty.
3. High voltage is always present on the rear panel auxiliary and test connectors. Use extreme caution at all times.
4. Do not ground the Phillips-head screws located immediately above the rear panel "PATCH, HI-IF, LO-IF, or L.O." connectors as this will result in damage (not covered by warranty) to the equipment because they are at a low voltage potential above DC ground.

CAUTION

1. Do not indiscriminately rotate the front panel "CALIBRATE" control or otherwise change its setting in either the receive mode or transmit mode, when positioned in or when pulled out as this will result in the improper VFO frequency unless it is adjusted in accordance with paragraph 2.3.4.
2. Use caution when adjusting the "TRANSMITTER OFFSET" control near each band edge as this may result in transmission outside of the amateur bands.

2.3.2 Single Channel Receive Mode Operation.

Do not energize the "AC" switch until specified in the following procedure, subparagraph g.

- a. Check that the Model CX7 is not being externally keyed for a transmit condition.

- b. Depress the front panel "PTT" switch.

- c. Check the position of the rear panel "AUX-COM" slide switch: If the antenna is connected to the connector immediately below the wing nut, set the switch to the "COM" position. This permits reception on the same antenna used for transmitting. If a different antenna is used for reception, and if it connected to the connector immediately above the slide switch, set the switch to the "AUX" position.

- d. Check that either the speaker or headphones are connected to the applicable connector. (If the headphones are utilized, the operation of the speaker will be inhibited.)

- e. Check that the rear panel "ACCESSORY" and "POWER" connectors and that the antenna and ground are securely fastened.

NOTE

The supplied accessory and power plugs must be utilized because they complete specific jumper connections required for the normal operation of the Model CX7.

- f. Check that the power cord is connected to an ac outlet.

- g. Depress the "AC" switch to the latched-in position and allow a few minutes for crystal frequency stabilization. Check that the Nixie tubes are illuminated and presenting a normal display.

- h. Set the "MODE" rotary selector switch to the "USB" position.

- i. Set the "MHZ" band selector to the "3" position.

- j. Set the "RECEIVE CHANNEL" switch (outer concentric control) to the "A" position.

- k. Set the AGC switch (outer concentric control) to the "SLOW" position.

1. Depress the "PLATE" meter switch to the latched-in position. Any meter indication will now represent relative received signal strength as an "S" meter.

m. Position the "RF GAIN" control (outer concentric control) for maximum gain to the "10" setting.

n. Position the "IF SHIFT" control to the "0" setting.

o. Position the "NOISE BLANKER" control to the "OFF" setting.

p. Position the "AF GAIN" control (inner concentric control) to a setting that provides a comfortable audio level for random noise.

q. Position the "PRESELECTOR" for either a peak audio noise or "S" meter indication.

r. Tune the "VFO-A" control until a desired station is monitored and adjust the remaining reception conditioning controls using the procedures covered in paragraphs 2.3.2.1 through 2.3.2.3, as required. When tuning to a new station, always remember to first set the "IF SHIFT" control to the "0" position and the "BLANKER" control to the "OFF" position.

s. If it is desired to use the other VFO instead, set the "RECEIVE CHANNEL" switch (outer concentric control) to the "B" position and tune in the desired station using the "VFO-B" control.

2.3.2.1 Operation of the "AGC" Switch. For CW reception, the "AGC" switch should be set to the "FAST" position. Some operators may prefer to utilize this switch in the "OFF" position and manually simulate AGC by adjusting the "RF GAIN" control. (However, the "OFF" position is normally not used except for performing alignment or conducting special tests.)

For SSB or AM reception, the "AGC" switch should be set to the "SLOW" position so that the AGC voltage will not sag between syllables.

2.3.2.2 Operation of the "IF SHIFT" Control. The "IF SHIFT" control is operated in the same manner for all modes of reception. This control should always be set to the "0" position while tuning in a station with the VFO control. If another station is interfering with the station you wish to receive, adjust the "IF SHIFT" control until the unwanted station is eliminated. This is very easy to accomplish in the cw mode with no apparent change in signal characteristics, however, in voice mode, the signal quality might be sacrificed as the control setting may also reduce either the high or low frequency response of the desired station.

2.3.2.3 Operation of the "BLANKER" Control. The "BLANKER" control is operated in the same manner for all modes of reception. When the "BLANKER" control is positioned to the full counterclockwise end, no noise blanking is performed. If objectionable noise pulses are being received along with the station you are monitoring, slowly advance the "BLANKER" control in the clockwise direction until the noise pulses have been reduced sufficiently. If this control is advanced too far, clipping and distortion will also occur in the station you are monitoring. Therefore, the minimum setting consistent with adequate limiting obtains the best effective results.

2.3.3 Dual Channel Receive Mode Operation. The same operating instructions that were specified for the single channel receive mode operation are also applicable for dual channel receive mode operation with minor exceptions. During this mode, the signal conditioning controls, such as "AGC", "IF SHIFT", "BLANKER", "RF GAIN", and "AF GAIN" cannot be used to command one channel without affecting the other channel. Therefore, the normal benefits derived from positioning these controls may have to be compromised during the dual receive mode operation. The following steps, a through d, comprise the basic procedure for establishing the dual channel receive mode:

a. Set the "RECEIVE CHANNEL" rotary selector switch (outer concentric control) to the "A" position and tune in the desired station using the "VFO-A" control.

b. Set the "RECEIVE CHANNEL" rotary selector switch (outer concentric control) to the "B" position and tune in a different station, that is within the same band, using the "VFO-B" control.

c. Set the "RECEIVE CHANNEL" rotary selector switch (outer concentric control) to the "DUAL" position. It is unlikely that both stations have the same signal strength, consequently the audio volume of the channel A and B will be unequal.

d. Adjust the "RECEIVE CHANNEL" potentiometer (inner concentric control) to a position that balances the audio outputs so they are equal. This control cannot increase the basic audio level, it can only reduce the existing level of the loudest station. Gradually rotating this control to the counterclockwise end proportionally decreases the output of channel B until it is completely eliminated. Likewise, gradually rotating this control to the clockwise end proportionally

decreases the output of channel A until it is completely eliminated. The "AF-GAIN" control (inner concentric control) will change the basic volume of both stations.

e. Tuning to a new station on either channel can be accomplished by using the same procedure as previously described in steps a through d.

Special cases may exist when one of the channels must be constantly monitored. If this is known prior to establishing the basic dual receive condition, use channel B for the constantly monitored channel because only the channel A VFO frequency is displayed. However, if it is desired to observe the VFO B display or tune to a new station with the aid of the display, perform the following procedures:

1. Position the "TRANSMIT VFO-B" switch to the latched-in position (frequency display still indicates VFO A).

2. Adjust the "SPOT LEVEL" control to the full counterclockwise position.

3. Depress the "SPOT" pushbutton to the "IN" position and hold (frequency display now indicates VFO B).

4. Upon completion of using the VFO B display, release the "SPOT" pushbutton (frequency display returns to VFO A).

2.3.4 Calibration Using the "PULL TO CALIBRATE" Control. Calibration using this control permits compensating for an incorrect intermediate frequency that is used in both the receive and transmit mode of operation. Care must be exhibited when utilizing this control because it is actively in the circuit for both the "IN" and "OUT" positions and could conceivably cause the calibration to be misadjusted by accident. The recommended calibration procedure is as follows:

a. Position the front panel switches and controls for the single channel receive mode of operation using either receive channel A or B.

b. Set the "MODE" rotary selector switch to the "USB" position.

c. Position the "IF SHIFT" control to the "-1.5" position.

d. Set the "MHZ" band selector switch to the desired band.

e. Tune the applicable "VFO A" or "VFO B" control for a front panel frequency display of "000.0" or any multiple 100 KHZ point.

f. Pull out the "PULL TO CALIBRATE" control and check for the presence of an audio zero beat caused by a harmonic of the 100 kHz internal frequency standard output.

NOTE

If the zero beat is not present, tune the applicable VFO control to determine if it occurs within ± 100 Hz of the "000.0" indication which signifies that calibration is within limits.

2.3.4.1 Compensation. Prior to performing any adjustments, check the calibration on the remaining bands to determine if similar symptoms exist and then perform one of the following compensations as required:

a. If the calibration is off on all bands by the same amount and direction, perform the calibration adjustment by first tuning either the applicable "VFO A" or "VFO B" control for a front panel frequency display of "000.0" and rotate the "PULL TO CALIBRATE" control to the position where the zero beat occurs. All bands have now been simultaneously calibrated.

b. In some cases, calibration may not be the same on all bands due to unequal aging of internal oscillator components. If desired, the "PULL TO CALIBRATE" control can be adjusted for frequency compensation for only a specific band in a similar manner as covered in previous subparagraph a. When a different band is selected, then it too will require calibration.

2.3.4.2 Calibration Using "WWV"

a. Set the "MODE" rotary selector switch to the "USB" position.

b. Position the "IF SHIFT" control to the "-1.5" position.

c. Set the "MHZ" band selector to the "14" position.

d. Tune in "WWV" on the high end of the band using the applicable "VFO A" and "VFO B" control.

e. Rotate the "PULL TO CALIBRATE" control to the position that produces a front panel frequency display of ".000.0" (15 MHz).

2.3.4.3 Calibrating Internal 100 kHz Standard.

a. Repeat the steps covered in paragraph 2.3.4.2(a) through (d).

b. Pull out the "PULL TO CALIBRATE" control.

c. Insert a small screwdriver through the special cut-out on the top right-hand side of the Model CX7 cover (refer to Figure 2-3 for exact location) and adjust capacitor C31 for a zero beat. This is best accomplished when WWV is transmitting a steady carrier. The zero beat is caused by 150th harmonic of the internal standard and the carrier of WWV.

2.4 Transmit Mode Operating Procedures

2.4.1 General. The general instructions covered in paragraph 2.4.1a through d are stated for information purposes and should not be performed at this time. Much of the general information specified in the receive mode general information paragraph 2.3.1a through g is also applicable and should be reviewed before actually operating the Model CX7 in the transmit mode. It is suggested that the operating procedure covered in paragraph 2.4.2 be performed initially with the Model CX7 connected to a dummy load, having a 50-ohm impedance, until the operator achieves the proper feel for the PA tuning and loading adjustment reactions.

a. Control of Power Output. The master control for power output is the "OUTPUT" potentiometer which varies RF drive to the final amplifier. When the transmitter is keyed, the "0" setting should present very little or essentially no power output. More than adequate drive is usually available, therefore, the majority of the controlling range normally utilized is between the "0" and "3" setting. It is safe to operate this control at settings higher than "3" as long as the screen current does not exceed an indication of "1.2" (12 MA) and the plate current does not exceed an indication of "3.3" (330 MA). The control should always be returned to the "0" setting before selecting a new frequency or prior to terminating final transmitter operation. During normal operation the Model CX7 should not be adjusted for a power output greater than 150 watts as the heat dissipation characteristics of the power amplifier will be exceeded.

b. Transmit Mode Metering Indications. The front panel meter is used for monitoring various transmit mode functions and provides a reference indication pertaining to the applicable meter switch that is set to the latched-in position. The different monitoring functions can be selected with or without power output present because all indications are relative, that is, the meter is not

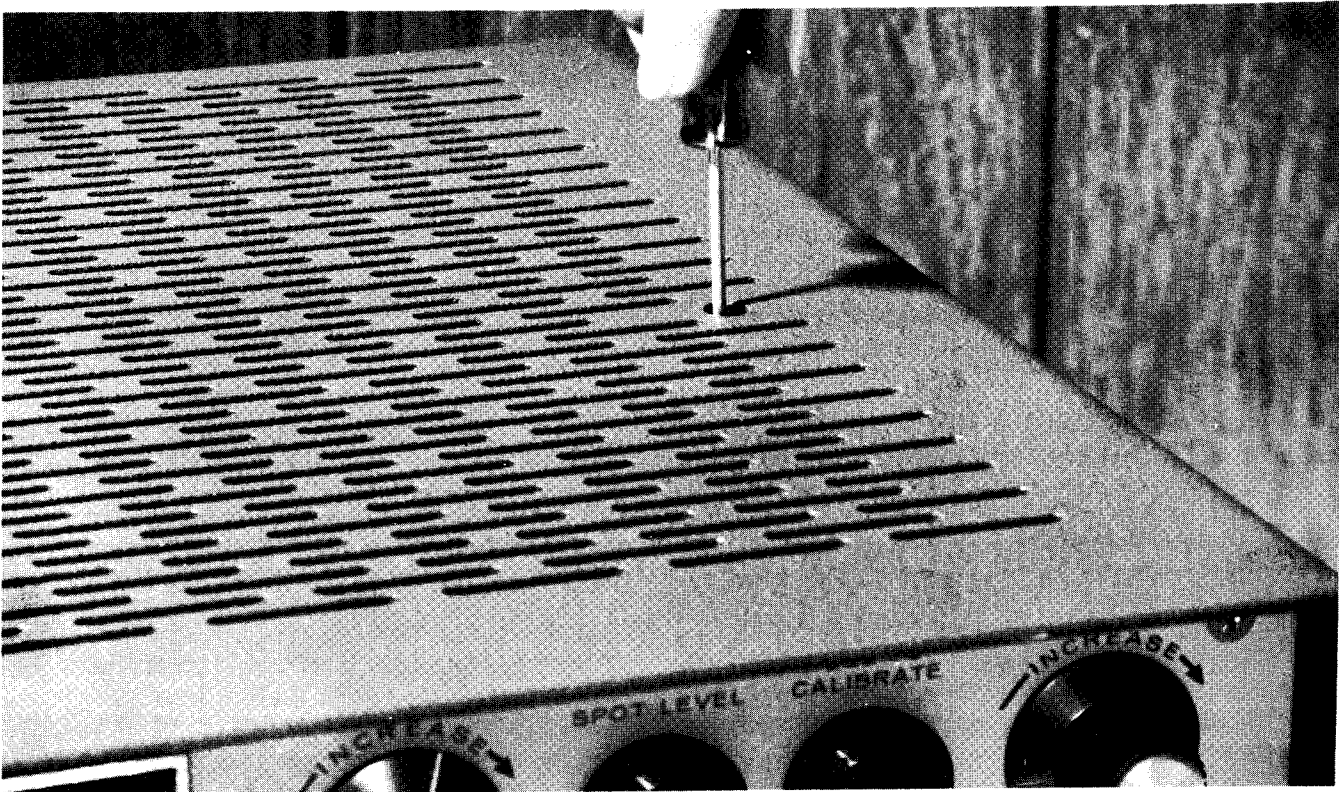

Figure 2-3. Capacitor C31 Location

directly in the circuit path of the function being monitored and will not interrupt transmitter operations. All the levels of parameters being measured, except clipping, are indicated on the black scale which is divided in units 0 through 5 with 4 subdivisions between each major division. The amount of clipping is indicated on the red scale. If all the meter switches are in the extended-out position, no transmit functions are monitored. Nominal and maximum meter indications for CW are listed in Table 2-3 for quick reference. The relationship between the meter indication and the actual value can be determined from the following:

1. Clipping. A nonlinear indication on the red scale that requires translating to determine an approximate amount of voice peak clipping. An S-3 to S-4 indication represents 10 DB of clipping and full scale represents 20 DB.

2. Drive. A nonlinear indication on the black scale that is used for reference only. Actual values are not significant as this indication represents the approximate amount of the composite

automatic level control (ALC) derived from either or both control and screen grid currents. An indication signifies that an ALC voltage is automatically reducing the RF drive so that the control and screen grid currents are not permitted to exceed their safe ratings.

3. Plate. A linear indication on the black scale that signifies the actual value of plate current. Each major division mark represents 100 milliamperes. Therefore, a full scale indication would be 500 milliamperes.

4. Screen. A linear indication on the black scale that signifies the actual value of screen current. Each major division represents 10 milliamperes. Therefore, a full scale indication would be 50 milliamperes. It is permissible for this indication to deflect in the negative direction during transmission or power amplifier tuning.

5. FWD PWR. A nonlinear indication on the black scale that requires translating to determine the actual amount of forward power output. To calculate the power output from the meter indication, refer to Table 2-4.

Function	Indications		
	Idling At Zero Watts	At 150 Watts	Maximum Safe Values
PLATE	1 (100 MA)	2 to 3 (200 to 300 MA)	3.3 (330 MA)
SCREEN	0	Less than 1.2 (12 MA)	1.2 (12 MA)
FWD PWR	0	4.2 (150 Watts)	4.2+ (150 Watts +) During voice or CW operation or 150 Watts maximum during continuous duty
REV PWR	0	See NOTE 2	See NOTE 2
DRIVE	0	Less than 5	Less than 5
CLIPPING	See NOTE 1	See NOTE 1	See NOTE 1

*NOTES:
 1. Not applicable, see paragraph 2.4.4.3.
 2. In BROADBAND MODE: Not more than the value which results in an SWR of 1.5:1. In MANUAL MODE: Not more than the value which results in an SWR of 3:1.

Table 2-3. Nominal Meter Indications

6. REV PWR. A nonlinear indication on the black scale that requires translating to determine the actual amount of reverse (reflected) power. Meter divisions for both forward or reverse indications represent the same value in watts. Reverse power can be calculated using Table 2-4.

c. Operation of the "BROADBAND/MANUAL" Switch. Two power amplifier tuning modes are provided in the choice of "BROADBAND/MANUAL" switch positions. The determining factor in choosing tuning modes is governed by characteristics resulting from the quality of antenna system being used. At any frequency where the standing wave ratio is less than 1.5:1, the broadband mode can be used. The advantage of using the broadband mode is that the "PA TUNING" and "LOADING" controls do not have to be adjusted thus reducing the tuning time.



Do not change positions of the "BROADBAND/MANUAL" switch when the Model CX7 is keyed for a transmit condition. Do not operate in the broadband mode whenever the VSWR exceeds 1.5:1. Always tune the power amplifier stage in the manual mode. Failure to observe any of the above instructions will result in damage to the equipment which is not covered by the warranty.

d. VFO Channel Selection and VFO Tuning. Three separate VFO channels are provided for the transmit mode: "VFO A", "VFO A/T.O.", and "VFO B". The Model CX7 can transmit on any one of these at any specific time. (Dual channel operation is only for the receive mode.) The VFO channels may be selected with or without power output present. To operate with "VFO A", depress the "TRANSMIT-VFO A" switch to the latched-in position and use the "VFO A" control for bandsread tuning. To operate with "VFO B", depress the "TRANSMIT-VFO B" switch to the latched-in position and use the "VFO B" control for bandsread tuning. To operate with "VFO A/T.O.", depress the "TRANSMIT-VFO A/T.O." switch to the latched-in position and use the "VFO A" control for bandsread tuning. The actual "VFO A/T.O." channel frequency may be offset from the "VFO A" frequency being displayed by the Nixie tubes by a constant specific

Meter Indication	Equivalent Watts
0.0	0
0.2	1
0.4	2
0.6	4
0.8	7
1.0	10
1.2	14
1.4	19
1.6	25
1.8	33
2.0	40
2.2	48
2.4	57
2.6	66
2.8	75
3.0	85
3.2	100
3.4	108
3.6	118
3.8	130
4.0	140
4.2	150
4.4	166
4.6	180
4.8	190
5.0	200

Table 2-4. Determining Actual Power

amount determined by the setting of the "TRANSMITTER OFFSET" control (up to 3 kHz). (The frequency offset tracks with the rotation of the "VFO A" tuning control.) The decimal point in the right-hand Nixie tube illuminates to provide a visual warning that the frequency readout is not indicating the actual transmitted frequency whenever the "VFO A/T.O." channel is being used.

WARNING

It is possible to transmit outside the authorized band by using the "VFO A/T. O." channel at the band edge and subsequently offsetting in the wrong direction. Therefore, tuning precautions should be observed.

e. Antenna System Checkout. Damage to the Model CX7 caused by a faulty antenna system can be prevented by adjusting for a low forward power meter indication of 1 (10 watts) and measuring the reverse power. If the reverse power meter indication is higher than 0.4 (2 watts), check for an open in the antenna system connections.

2.4.2 Tune Mode Operation. (Do not energize the "AC" switch until specified to do so in the following procedure, subparagraph f.) Note that in this initial procedure, the transmitter is not keyed until reaching subparagraph m.

a. Check that the Model CX7 is not being externally keyed for a transmit condition.

b. Depress the front panel "PTT" switch, thereby ensuring that a receive mode will be established.

c. Check that either the speaker or headphones and either the mike or the key are connected to the applicable connector. (If the headphones are utilized, the operation of the speaker will be inhibited.)

d. Check that the rear panel "ACCESSORY" and "POWER" connectors and that the main antenna and ground connections are securely fastened.

NOTE

The supplied accessory and power plugs must be utilized because they complete specific jumper connections required for the normal operation of the Model CX7.

e. Check that the power cord is connected to an ac outlet.

f. Depress the "AC" switch to the latched-in position and allow a few minutes for crystal frequency stabilization. Check that the Nixie tubes are illuminated and presenting a normal display.

g. Set the "MODE" rotary selector switch to either the "AM", "LSB", "USB", or "CW1" position.

NOTE

The tune mode is not dependent upon any particular "MODE" switch setting.

WARNING

Do not change positions of the "MHZ" band selector when the Model CX7 is keyed for a transmit condition, as this will result in damage to the equipment which is not covered by the warantee.

h. Set the "MHZ" band selector to the "3" position.

i. Set both the "OUTPUT" control (inner concentric control) and "CLIPPING" control (outer concentric control) to the "0" position.

j. Set the "BROADBAND/MANUAL" switch to the "MANUAL" position.

k. Depress the "TRANSMIT VFO A" switch to the latched-in position.

l. Depress the "PLATE" meter switch to the latched-in position.

m. Set the "LOADING" control to the mid-range position between the "6" and "7" settings.

n. Set the "PA TUNING" control (inner concentric control) to the "6" position.

o. Depress the "TUNE" switch to the latched-in position. The transmitter is now keyed and minimum power output is present. The front panel meter should indicate "1" (100 MA) for an idling plate current (80 to 100 MA is normal).

p. With the "OUTPUT" control in the "0" position, tune the "VFO A" control to a frequency in the middle of the band (or the frequency you wish to transmit on).

q. Depress the "SCREEN" switch to the latched-in position. The front panel meter should indicate "0" (no screen current should be present at this time).

r. Tune the power amplifier stage in accordance with the following steps 1 through 9:

NOTE

The overall objective of this procedure is to obtain an RF power output of 150 watts or more, a minimum plate current in the 200 to 300 MA range, and a minimum screen current of less than 12 MA.

1. Rotate the "OUTPUT" control from 0 to 1 and back to 0 while observing the screen meter indication. If the screen current increased in level, adjust the "OUTPUT" control until the meter indicates "1.0" (10 MA) without advancing the "OUTPUT" control beyond "3". If the screen did not change or if it decreased below "0", depress the "PLATE" switch to the latched-in position and adjust the "OUTPUT" control until the meter indicates "2.6" (260 MA).

2. Depress the "FWD PWR" switch to the latched-in position and note the forward power indication on the meter for future reference. Little or no power may be present.

3. Depress the "PLATE" switch to the latched-in position and adjust the "PA TUNING" (inner concentric control) for the lowest point in the dip of the plate meter indication while not permitting it to exceed "3.3" (330 MA). The dip should occur between "2" and "2.6" (200 and 260 MA).

4. Depress the "FWD PWR" switch to the latched-in position and note the forward power indication on the meter for future reference. An increase in power above that noted in the previous measurement should be observed.

5. Depress the "SCREEN" switch to the latched-in position and adjust the "LOADING" control for the lowest point in the dip of the screen meter indication while not permitting it to exceed "1.2" (12 MA). The dip should occur between "0" and "0.4" (0 and 4 MA) on the meter.

NOTE

When plate current is dipped, screen current will peak. Therefore, during the remaining steps, the "PA TUNING" and "LOADING" controls can be adjusted for a peak screen current as long as the screen current is not permitted to exceed 12 MA.

6. Depress the "FWD PWR" switch to the latched-in position and note the forward power indication on the meter for future reference. The power output should be higher in level than that noted in step 4. If not, repeat steps 3 through 6 until an increase to at least "3.8" (130 watts) is noted.

7. Depress the "PLATE" switch to the latched-in position and slightly advance the "OUTPUT" control for a plate meter indication of "3".

8. Depress the "SCREEN" switch to the latched-in position and check that the screen meter indication is still less than "1.2".

9. Depress the "FWD PWR" switch to the latched-in position and note the forward power indication on the meter. The indication should be at least "4.2" which represents a power out of 150 watts. If it is higher, reduce the setting of the "OUTPUT" control to the point where "4.2" is indicated. If the initial indication was less than "4.2", slightly and in unison, rock the "PA TUNING" (inner concentric control) and the "LOADING" controls in both opposing and both unopposing directions to locate a final setting where a minor change in either won't adversely affect the respective plate or screen current indication while keeping the adjustment parameters within the specified limits.

NOTE

A forward power output of 130 watts is satisfactory for any frequency above 28 MHz.

s. The tuning mode is now complete. Adjust the "OUTPUT" control for the forward power level that you wish to conduct transmission with and depress the "PTT" switch, thereby placing the Model CX7 in the receive mode.

2.4.3 Normal Transmit Channel Operation

2.4.3.1 Operating with a VSWR Less than 1.5:1

a. Establish a receive mode.

b. Select the desired band with the "MHZ" rotary selector switch.

c. Tune the applicable "VFO A" or "VFO B" control to the desired bandspread frequency.

d. Depress the applicable "TRANSMIT VFO A" or "TRANSMIT VFO B" switch to the latched-in position.

e. Set the "BROADBAND/MANUAL" rotary switch to the "BROADBAND" position.

f. Depress the "FWD PWR" switch to the latched-in position.

g. Depress the "TUNE" switch to the latched-in position.

h. Adjust "OUTPUT" control for a 1.6 forward power meter indication.

i. Depress the "REV PWR" switch to the latched-in position and note the reverse power meter indication. If the indication is "0.2" (1 watt) or less for reverse power and "1.6" (25 watts) or more for forward power, proceed to step j. If the reverse power indication is higher than 0.2, omit step j and proceed to paragraph 2.4.3.2.

j. Depress the "FWD PWR" switch to the latched-in position and adjust the "OUTPUT" control for a 4.2 (150 watts) meter indication.

The Model CX7 can now be keyed for the desired transmission. Prior to changing to a new transmit frequency, perform the following:

1. Establish a receive mode.
2. Use the procedure recommended in paragraph 2.4.3.1b through i.

WARNING

Failure to comply with the previous steps 1 and 2 will result in damage to the Model CX7.

2.4.3.2 Operating with a VSWR Exceeding 1.5:1

- a. Establish the receive mode.
- b. Set the "BROADBAND/MANUAL" switch to the "MANUAL" position.
- c. Depress the "TUNE" switch to the latched-in position.
- d. Depress the "SCREEN" switch to the latched-in position.
- e. Tune the power amplifier stage using the procedure covered in paragraph 2.4.2r.

f. Depress the "PTT" switch to the latched-in position thereby establishing the receive mode.

The Model CX7 can now be keyed for the desired transmission. Prior to changing to a new transmit frequency, perform the following:

1. Establish a receive mode.
2. Use the tuning procedure recommended in paragraph 2.4.2r.

WARNING

Failure to comply with the previous steps 1 and 2 will result in damage to the Model CX7.

2.4.4 Single Sideband Transmission

a. Perform the operations required for normal transmit channel operation as directed in paragraph 2.4.3.

b. Check that the microphone is connected.

c. Set the "MODE" selector to either the "LSB" or "USB" position as desired.

d. Key the transmitter in accordance with the applicable following paragraphs and conduct transmission as desired.

2.4.4.1 Manual Keying

a. To key the Model CX7 so that actual voice messages can be transmitted, perform either of the following:

1. Depress the "TRANSMIT" switch to the latched-in position.

2. Position the "PUSH-TO-TALK" switch located on the microphone to the "ON" or "TALK" position.

NOTE

Step 1 does not have to be performed if keying is accomplished using step 2.

2.4.4.2 VOX-ANTI-VOX Keying

a. Depress the "VOX" switch to the latched-in position.

b. Set the "VOX GAIN" control (on the rear panel) to the midrange position.

c. Set the "ANTI-TRIP" control (on the rear panel) to 1/4 from the full counterclockwise position.

d. Set the "PUSH-TO-TALK" switch located on the microphone to the "LISTEN" or "OFF" position (additional positioning of this switch is not required).

e. Refine the setting of the "ANTI-TRIP" control to the point just slightly more than the position that permits the Model CX7 to key on ambient noise or audio from the speaker.

f. Refine the setting of the "VOX GAIN" control to the point where the Model CX7 keys at normal voice levels.

NOTE

For best results, use the minimum settings of the "VOX" and "ANTI-VOX" controls as excessive gain in these circuits is not desirable.

g. Normal speech will now switch the Model CX7 from the receive mode to the transmit mode. If spoken end syllables are cut off by the transmitter unkeying, advance the setting of the rear panel "DELAY" control for an appropriate unkeying delay time.

2.4.4.3 Operation of "CLIPPING" Control

a. Depress the "CLIPPING" meter switch to the latched-in position.

b. While conducting a voice transmission, slowly increase the setting of the "CLIPPING" control until the front panel meter registers from S-3 to S-4 during voice peaks. This setting provides approximately 10 DB of clipping causing a significant increase in TALK POWER under conditions of marginal signal to noise. Utilizing the clipping function increases the overall system gain which results in accentuation of background noise. For this reason, it is always desirable to use a minimum amount of clipping.

2.4.5 AM Transmission

a. Perform the operations required for normal transmit channel operation as directed in paragraph 2.4.3 except set the power output for 1.9 (35 watts).

b. Check that the microphone is connected.

c. Set the "MODE" selector to the "AM" position.

d. While conducting a voice transmission, adjust the "CLIPPING" control for a forward power indication of 2.8 (75 watts) during voice peaks.

2.4.6 CW Transmission

2.4.6.1 Normal Telegraph Key Operation

a. Depress the "PTT" switch to the latched-in position.

b. Set the "CLIPPING" control to the "0" position.

c. Set the "MODE" rotary selector to the "CW1" position.

NOTE

The "CW2" or "CW3" positions will interrupt the transmit signal path unless the optional CW filters have been installed.

d. Depressing the telegraph key automatically switches the Model CX7 from the receive to the transmit mode and causes excitation.

e. With the telegraph key depressed, adjust the rear panel "SIDETONE" control for the desired audio signal level. (This may be accomplished with or without power output present.)

f. Releasing the telegraph key automatically causes the Model CX7 to revert back to the receive mode.

2.4.6.2 Paddle Key Operation

a. Connect the paddle key to the applicable rear panel connector.

b. Follow the operating procedure for normal telegraph key operation covered in paragraph 2.4.6.1.

c. With the paddle set to either side position, adjust the "KEYER SPEED" control for the desired number of characters per minute. (This may be accomplished with or without power output present.)

NOTE

When operating at keyer speeds exceeding 25 words per minute, it is recommended that a fan be utilized with its air flow directed on the rear panel heat sink.

2.4.6.3 Offset Channel Operation

a. Normal channel operating procedures are also applicable when in the offset channel mode except the "VFO B" tuning control is not utilized. It is advantageous to use the offset channel mode whenever "VFO A" is being used in the receive mode.

b. Depress the "TRANSMIT VFO-A/T.O." switch to the latched-in position. The decimal point on the right hand Nixie tube illuminates as a visual indication that this mode is being used and has no significance in determining the frequency readout of the KHZ display.

c. Set the "TRANSMITTER OFFSET" (inner concentric control) a few degrees to the left or right of the midrange position.

d. Depress and hold in the "SPOT" pushbutton while adjusting the "SPOT LEVEL" control for a comfortable audio level.

e. While still in the receive mode and with the "SPOT" pushbutton held in, rotate the "TRANSMITTER OFFSET" control from the midrange position toward the right to increase the basic "VFO A" frequency for the transmit mode. If it is desired to offset to a lower frequency, rotate the control from the midrange position toward the left. It is possible to offset the frequency to be transmitted, by as much as 3 kHz, from the "VFO A" channel utilized by the receive mode. The actual amount of offset can only be determined by the audio frequency that is heard whenever the "SPOT" pushbutton is depressed. (This is very similar to spotting a separate CW transmitter and receiver except it is accomplished by the transceiver when in a receive mode.) The amount of offset tracks with the rotation of the "VFO A" tuning control.



It is possible to transmit outside the authorized band when operating near the band edge and subsequently offsetting in the wrong direction.

f. Release the "SPOT" pushbutton and key the transmitter using either the hand or paddle key.

2.4.7 FSK Mode

NOTE

1. FSK transmission is continuous duty operation therefore it is recommended that a fan be utilized with its air flow directed on the rear panel heat sink.

2. It may be necessary to reverse the teletypewriter signal leads to obtain the correct "MARK" and "SPACE" inversion.

a. Set the "MODE" rotary selector switch to the "FSK" position. (This position will interrupt the transmit signal path unless the optional FSK filter has been installed.)

b. Check that the external teletypewriter and FSK tone converter interconnections have been properly connected to the rear panel accessory plug.

c. Depress the "TRANSMIT VFO B" switch to the latched-in position.

d. Adjust the "VFO B" tuning control for the frequency indication of the desired nonshifted frequency.

e. Physically ground the external FSK keyline at the appropriate teletypewriter output terminal.

f. Adjust the front panel "FSK SHIFT" control for the frequency indication on the "MHZ" display for the desired shifted frequency.

g. Remove the ground from the FSK keyline.

h. Tune up the power amplifier stage using "VFO A" tuned to the frequency midrange between the shift in accordance with the recommended procedure in paragraph 2.4.3 and then switch the transmit VFO back to the "B" channel.

i. Proceed with operations as follows:

1. Prior to transmitting from the teletypewriter, depress the "TRANSMIT" switch to the latched-in position.

2. Prior to receiving, depress the "PTT" switch to the latched-in position.

2.4.8 Linear Amplifier Operation. When operating with a linear amplifier, special precautions must be followed when keying the transmitter. The Model CX7 possesses extremely fast T/R keying characteristics that cannot be equaled by linear amplifiers. Consequently, the Model CX7 would be temporarily unloaded, with power output present, during the time a linear amplifier is switching from a receive to a transmit mode.

A rectangular box with a thick black border containing the word "WARNING" in bold, uppercase letters.

WARNING

Failure to use manual keying, when the Model CX7 is driving a linear amplifier, will result in damage to the Model CX7. Allow sufficient time for the linear amplifier to switch modes before exciting the Model CX7.