

# REPEATER MANUAL

1854

MODEL RPT-50 • MODEL RPT-144 • MODEL RPT-220 • MODEL RPT-432

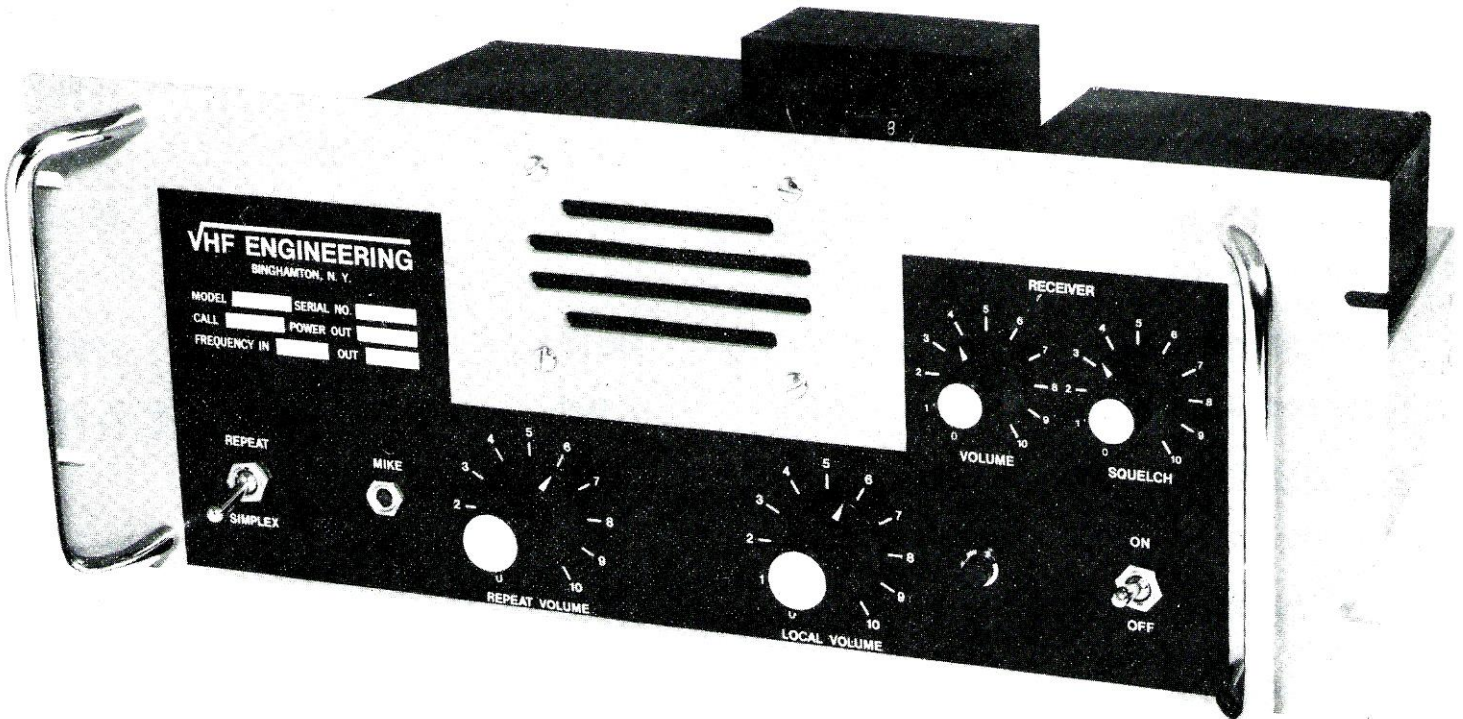

INSTRUCTION MANUAL  
#5010901 REV.02  
DECEMBER 1977

PRICE: \$5.00

**Vhf engineering**

DIVISION OF BROWNIAN ELECTRONICS CORP.

320 WATER ST. / BINGHAMTON, N.Y. 13901 / Phone 607-723-9574

for free by  
RadioAmateur.eu

Thank you for purchasing this VHF Engineering kit. We hope you will get as much pleasure and satisfaction out of building and using this unit as we have from designing it for you. Please read all of the enclosed material carefully. Unlike kits which are produced for the general public, this kit was designed for the ham who has some home-brew experience and technical knowledge. If you encounter problems in alignment or testing, don't hesitate to obtain assistance from a competent fellow ham near you or here at VHF Engineering.

*Bob Brown Will Kupfrian*

Bob Brown  
W2EDN

Will Kupfrian  
W2BVA

The construction techniques and procedures in this manual are very important to the proper and easy building of VHF Engineering kits. If your previous experience has been with unminiaturized equipment the following information should prove invaluable. To build miniaturized equipment using P.C. boards requires extra patience and care, normal dexterity, and the proper tools for the job.

### GENERAL NOTES

A. A good soldering job is essential to the satisfactory performance of this unit. Soldering to etched circuit boards is easier than conventional point to point wiring when it is done correctly.

Use rosin core solder only (1/16" or smaller is easiest to work with). Acid core solder or paste fluxes will cause corrosion and void all warranties. Use a clean, freshly tinned soldering iron of about 30-35 watts. (A controlled temperature type is preferred). A small tip will greatly reduce bridging and similar problems.

When soldering a part to the P.C. board, the solder must completely surround the wire lead where it comes through the board. Do not apply excessive solder, but do not hesitate to apply sufficient heat to assure a smooth flow of solder all around the lead and onto the board. Do not worry about overheating semiconductors. It is likely that P.C. board lands will be lifted long before a semiconductor device is damaged.

B. Leads on resistors, capacitors, transistors etc. are often longer than required. These leads should be trimmed as short as possible unless specific directions to the contrary are given in the instructions.

As a general rule all parts should be mounted as close to the board as possible. In the case of capacitors it may be necessary to scrape the body coating off of the leads to allow the bottom of the capacitor to rest on the board.

C. Inspect your work after each step and check off the steps as they are completed. You will find it helpful to check off capacitors, resistors, etc. on the parts list as they are installed. This will save you time and mistakes.

D. Check and double check the direction in which polarized components should be installed. In particular, take great care when inserting transistors, I.C.'s, electrolytic and tantalum capacitors etc. Remember the old carpenters rule "Measure twice and cut once".

# SPECIFICATIONS

|  | <u>RPT-50</u> | <u>RPT-144</u> | <u>RPT-220</u> | <u>RPT-450</u> |
|--|---------------|----------------|----------------|----------------|
| <u>Transmitter</u>   |               |                |                |                |
| Frequency Range  | 49-54MHz      | 142-175MHz     | 210-240MHz     | 420-470MHz     |
| RF Power Output (nominal)                                  | 25W           | 15W            | 15W            | 10W            |
| Frequency Stability<br>(-10 degrees C to<br>+60 degrees C) | .001%         | .001%          | .001%          | .001%          |
| Modulation-FM<br>(adjustable to)                           | 5kHz          | 10kHz          | 15kHz          | 30kHz          |
| Output Impedance   | 50ohms        | 50ohms         | 50ohms         | 50ohms         |

## Receiver

|  |                |                |                |                |
|--|----------------|----------------|----------------|----------------|
| Frequency Range  | 49-54MHz       | 142-175MHz     | 210-240MHz     | 420-470MHz     |
| Sensitivity (20dB quieting)                                | .3uV           | .3uV           | .3uV           | .3uV           |
| Selectivity $\pm$ 30kHz<br>(optional $\pm$ 25kHz)          | 70dB<br>(90dB) | 70dB<br>(90dB) | 70dB<br>(90dB) | 70dB<br>(90dB) |
| Frequency Stability<br>(-10 degrees C to<br>+60 degrees C) | .001%          | .001%          | .001%          | .001%          |
| Modulation Acceptance                                      | $\pm$ 7.5kHz   | $\pm$ 7.5kHz   | $\pm$ 7.5kHz   | $\pm$ 7.5kHz   |

## Power Requirements

|                         |    |      |      |      |
|-------------------------|----|------|------|------|
| 117VAC Maximum Current  | 1A | 1A   | 1A   | 1A   |
| or                      |    |      |      |      |
| 13.8VDC Maximum Current | 5A | 3.5A | 3.5A | 3.5A |

### LIMITED WARRANTY

The enclosed warranty card must be filled out and returned within 10 days of purchase.

Units are warranted for 90 days from purchase date. VHF Engineering's liability is limited to the repair, adjustment or replacement of units of the original consumer purchaser that are proven defective. R.F. power devices are warranted to be within 1dB of specification. Units modified or operated in a manner not consistent with the instructions in the manual will not be covered by this warranty.

Defective units must be returned to the factory at the address below with a description of the difficulty and the date of purchase. VHF Engineering is not liable for any damage occurring in shipment, so the unit should be packed properly. The customer must pay all shipping costs. Further information may be obtained by calling VHF Engineering's Customer Service Department at (607) 723-9574 (collect calls will not be accepted) or writing:

Customer Service Department  
VHF Engineering  
320 Water Street  
Binghamton, New York 13901

The consumer must pay all shipping costs.

No other warranties are expressed or implied. VHF Engineering is not responsible for damages which result as a consequence of or incident to using this unit.

Some states do not allow limitations on how long an implied warranty lasts, so the above limitation may not apply to you. Some states do not allow the exclusion or limitation of incidental or consequential damages, so the above limitation may not apply to you. This warranty gives you specific legal rights, and you may also have other rights which may vary from state to state.

Ø-

## TABLE OF CONTENTS

| <u>SECTION</u> | <u>TITLE</u>                           | <u>PAGE</u> |
|----------------|--|-------------|
|                | Specifications                         | Cover II    |
|                | Warranty                               | Cover II    |
| I.             | Description                            | 2           |
| II.            | Installation                           | 2           |
| III.           | Operating Instructions                 | 6           |
| IV.            | Theory of Operation                    | 6           |
| V.             | Tune-Up Procedures                     | 8           |
| VI.            | Servicing                              | 8           |
| VII.           | Customer Service                       | 8           |
| VIII.          | Appendices                             | 9           |
|                | A - Antenna Requirements               | 9           |
|                | B - Duplexers                          | 10          |
|                | C - Common Repeater Problems           | 10          |
|                | D - Accessory Interfacing              | 13          |
|                | E - Supplementary Manuals and Diagrams | 13          |

## I. DESCRIPTION

VHF Engineering has designed its series of repeaters, the RPT-50, RPT-144, RPT-220 and RPT-432 for use on the amateur frequencies and those MARS frequencies adjacent to the amateur bands. These solid state repeaters are constructed from high quality components and will offer excellent performance with a minimum of service.

The repeaters consist of a receiver, transmitter, and amplifier, all in shielded enclosures; a power supply, and a Morse code identifier. Interfaces are provided to permit connection to an auto-patch or an optional touchtone control decoder. The units come complete with a local microphone and monitor speaker and are designed for either 19" rack mounting or for table top operation.

VHF Engineering offers a touchtone decoder control unit (TD-3) and a private line (PL) control unit (TS-1) for repeater use. The TD-3 takes standard touchtones or other selected tones from the repeater input or from an auxiliary source and provides control of repeater functions. The TS-1 takes standard private line (PL), subaudible tones from the repeater input and provides repeater access. Both units are supplied with information for interfacing to the VHF Engineering repeaters.

## II. INSTALLATION

### Antennas

In a good repeater installation it is important to erect a good antenna system as discussed in the appendix entitled "Antenna Requirements". It is also important to use a good quality 50ohm (nominal) antenna cable such as RG-8U for the antenna feedlines. For frequencies above 150MHz, or for runs longer than 100 ft, a low-loss hard line is "preferred". The receive and transmit feedlines between the repeater and the duplexer or their respective antennas must be separated by at least 6-12 inches. Due to the fact that coax has some leakage, the cables should not be taped into one bundle or passed through the same hole in the wall of the repeater installation. In duplexer installations double shielded coax cables between the repeater and duplexers is preferred. Any signal leakage between the receiver and transmitter cables or excessive losses in the antenna cables will degrade repeater performance.

### Receiver Preamps

Receiver preamps are not recommended. Most preamps will amplify the unwanted signals as well as the wanted and will just create intermod and front end overload.

### Power Amplifiers

If additional transmit power is needed, a power amplifier may be added. Keep in mind that for every dB the transmit power is increased, an additional dB must be added to the minimum 60dB antenna separation requirement. The amplifier selected must be able to handle the high duty cycle encountered in repeater operation.

## INITIAL ADJUSTMENTS

The repeater must not be operated unless a properly matched antenna or dummy load is connected to the "RF OUT". Failure to follow this instruction may result in permanent damage to the final amplifier.

- 1.) Connect the receive antenna to "RF IN". Connect the transmit antenna to "RF OUT". An isolation figure of at least 60dB is necessary. See Appendix A for the required antenna separation. Cavities or duplexers with 60dB or better isolation will also be suitable.
- 2.) Preset controls as follows:  
ON-OFF to off  
REPEAT - SIMPLEX to simplex  
LOCAL VOLUME to full on (C.W.)  
REPEAT VOLUME TO FULL OFF (CCW)  
SQUELCH to full off (CCW)  
VOLUME to one-half
- 3.) Plug the line cord into a 120 V.A.C. outlet.
- 4.) Turn the power (ON-OFF) switch to "ON". The pilot light will light and background noise should be heard at this point.
- 5.) Set the RECEIVE - VOLUME slightly above a comfortable level of background noise.
- 6.) Set the SQUELCH control to quiet the receiver.
- 7.) Set the REPEAT - SIMPLEX switch to repeat.
- 8.) Set the REPEAT VOLUME. This can be accomplished in the following manners depending upon the available equipment.  
NOTE: Receive VOLUME changes will affect REPEAT VOLUME settings.
  - a.) If a modulated signal generator and deviation meter are available, inject a 1kHz modulated signal having 3kHz deviation into the repeater input and, while monitoring the deviation of the output signal, adjust REPEAT VOLUME until an output signal with 3kHz deviation is obtained.
  - b.) If such equipment is not available, an acceptable adjustment can be made with a monitor receiver capable of receiving the repeater input and output frequencies.
    1. Tune the monitor receiver to the input frequency of the repeater. Connect a sensitive AC voltmeter across the speaker terminals and adjust the volume setting to give a reading of at least a quarter of scale for the "calibrating" signal. This "calibration" signal can be any repeatable signal from a friend's transmitter; e.g., whistling a fixed distance away from a microphone. Note this reading; it is used in the next step. (The monitor receiver is "calibrated", do not touch its volume setting.)

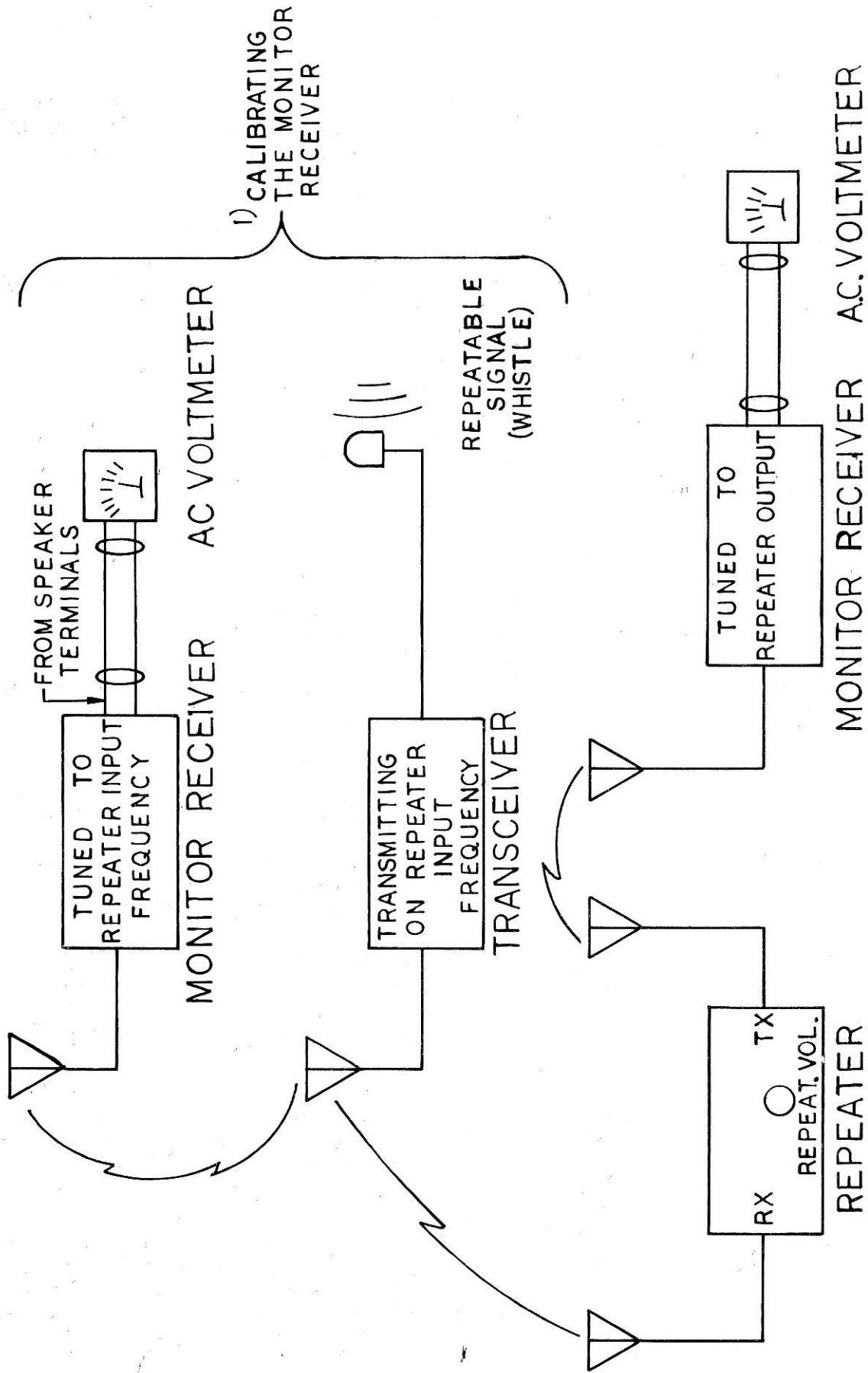

2) SETTING REPEAT VOLUME

(4)

2. Tune the monitor receiver to the output frequency of the repeater and have the "calibrating" signal repeated at the input frequency of the repeater. Adjust the REPEAT VOLUME until the meter reading obtained in step 1 is indicated. This completes the deviation adjustment.

When the monitor receiver is switched from the input to output, little change in volume for a given signal should be noticed if this step is successful.

NOTE: DO NOT TOUCH THE DEVIATION CONTROL ON THE TX BOARD. IT IS SET AT THE FACTORY TO GIVE PROPER DEVIATION FOR THE LOCAL MICROPHONE. IF THE TX BOARD IS SERVICED OR CHANGED, REFER TO THE TX MANUAL FOR DEVIATION ADJUSTMENT PROCEDURE.

- 9.) COR ADJUSTMENTS: Refer to the COR manual for proper adjustments.
- 10.) CWID ADJUSTMENTS: Refer to the CWID manual for proper adjustments.

### III. OPERATING INSTRUCTIONS

The repeater should be in proper operating condition after following the details of the installation instructions. The REPEAT VOLUME and receive VOLUME were set then. The repeater need only be checked by a monitor receiver and frequency counter periodically to insure its proper operation. The remainder of the controls can be set as needed.

- 1.) The LOCAL VOLUME to comfortable level.
- 2.) The SQUELCH to a level for reliable operation and desired range of acquisition by controlling the minimum strength signal to bring the repeater up.
- 3.) MIKE INPUT: For at site communication: especially useful for coordinating adjustments of the repeater system.
- 4.) REPEAT - SIMPLEX switch:

The SIMPLEX position disables the COR circuitry. The received signal is not repeated, but the audio is delivered to the repeater's speaker.

In the REPEAT position, the repeater retransmits the signal as detailed in the "Theory of Operation".

In both positions, the local microphone can be used for transmission.

### IV. THEORY OF OPERATION

The receive audio signal is combined with the audio from the CW identifier and any input from the AUDIO IN jacks, and is fed to the transmitter line input for re-transmission. The receiver also provides a control signal to the COR terminal of the carrier oper-



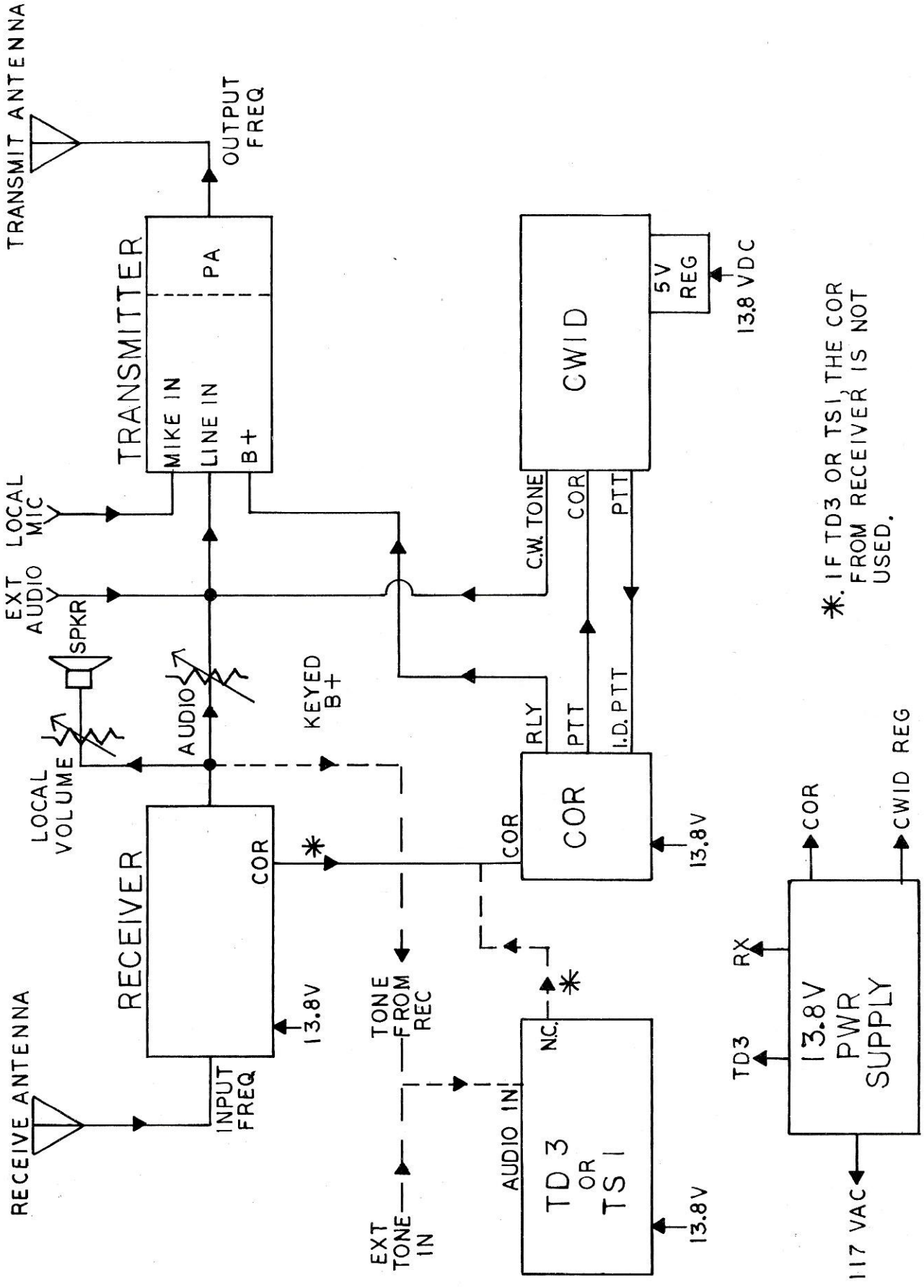

\*. IF TD3 OR TS1, THE COR FROM RECEIVER IS NOT USED.

VHF ENGINEERING REPEATER SYSTEM

ated relay and timing circuit (the COR). When a signal is present, the COR keys the transmitter and power amplifier and starts the time out timer. The time out timer will time for a fixed period (approximately 3 minutes) and will turn off the transmitter-amplifier at the end of this period unless the received signal disappears before the time out occurs. The squelch tail timer will hold the transmitter power on for about 3 seconds (adjustable) after the received signal disappears. After this time the transmitter is turned off and both COR timers are reset. If the repeater times out, the received signal must be dropped before the COR timers are reset and the transmitter can be powered again.

The CWID's operation is dependent upon the PTT output from the COR. When a signal is present at the receiver input after a long idle period, the CWID will provide a keyed audio tone of the repeater's programmed call sign. The CWID keeps the repeater from timing out during this identification by providing a signal to the COR's ID PTT terminal. The timer in the CWID circuit will reset and begin to time at the end of the tone identification. This timer will time for an adjustable period, typically 3 minutes. After this period the CWID will identify again, provided a signal is still being received.

#### V. TUNE-UP PROCEDURES

Wired and tested units are tuned to specifications at the factory using standard 50ohm termination. If properly installed, no tuning should be necessary. However, if tuning is necessary, consult the supplementary manuals describing the unit to be tuned.

#### VI. SERVICING

For servicing information consult the supplementary manuals at the end of this manual.

#### VII. CUSTOMER SERVICE

VHF Engineering's Customer Service department will assist customers with technical problems concerning all VHF Engineering units. Should assistance be required, please contact the Customer Service Department at (607) 723-9574. Units having serious problems may be returned postpaid to the factory without authorization for evaluation and repair estimates with a note detailing the difficulty. Units qualifying for warranty service will be covered according to the warranties detailed in their manuals. For units not covered by a warranty, a nominal service fee plus parts and return postage will be charged.

Address units to be returned to: Customer Service Department  
VHF Engineering  
320 Water Street  
Binghamton, New York 13902

## VIII. APPENDICES

### APPENDIX A - ANTENNA REQUIREMENTS

In order for the repeater to operate correctly, isolation must be provided between the transmit and receive antennas. The minimum required isolation for VHF Engineering repeaters is in the order of 60dB. The most practical way to achieve this isolation is to use a duplexer in conjunction with a single antenna. Duplexers typically provide isolation in the range of 80dB.

Repeaters may also be operated using separate antennas for the transmitter and receiver. If this is the case, sufficient vertical or horizontal separation is required to provide the needed isolation.

The following separations may be used for  $\frac{1}{2}$  wave dipole antennas:

#### Approximate 60dB Isolation Distances

| <u>Band</u>           | <u>50MHz</u> | <u>146MHz</u> | <u>220MHz</u> | <u>440MHz</u> |
|-----------------------|--------------|---------------|---------------|---------------|
| Vertical Separation   | 200'         | 50'           | 30'           | 20'           |
| Horizontal Separation | 2,500'       | 800'          | 500'          | 250'          |

Obviously, vertical separation is more practical and is generally used. Vertical separation takes advantage of the radiation null off the ends of a vertical antenna. Any horizontal offset will degrade this isolation figure. Therefore, for best results, it is important to mount the antennas directly over one another. For maximum range, the top antenna should be connected to the receiver.

The 60dB separation distances shown in the table above are the minimum spacing for  $\frac{1}{2}$  wave dipoles. The minimum multi-element higher gain antenna spacing will vary depending on radiation patterns and reflection from ground or other objects.

The antenna isolation figure can be accurately measured by using the following procedure:

Connect a calibrated signal generator (Measurements Model 800A or equivalent) to the repeater's receiver antenna jack through a short piece of coax. Center the generator's output frequency in the receiver's bandpass and note the lowest output level required to open the squelch (Typically about - 127dBm (.29uV)). Then connect the transmitter antenna to the signal generator and connect the receiver antenna to the repeater's receiver. Increase the output of the generator until the squelch breaks. Recheck the generator's output frequency to insure that it is in the center of the receiver bandpass. Again, note the lowest output level needed to open the squelch. Subtract the reading in dBm from the earlier

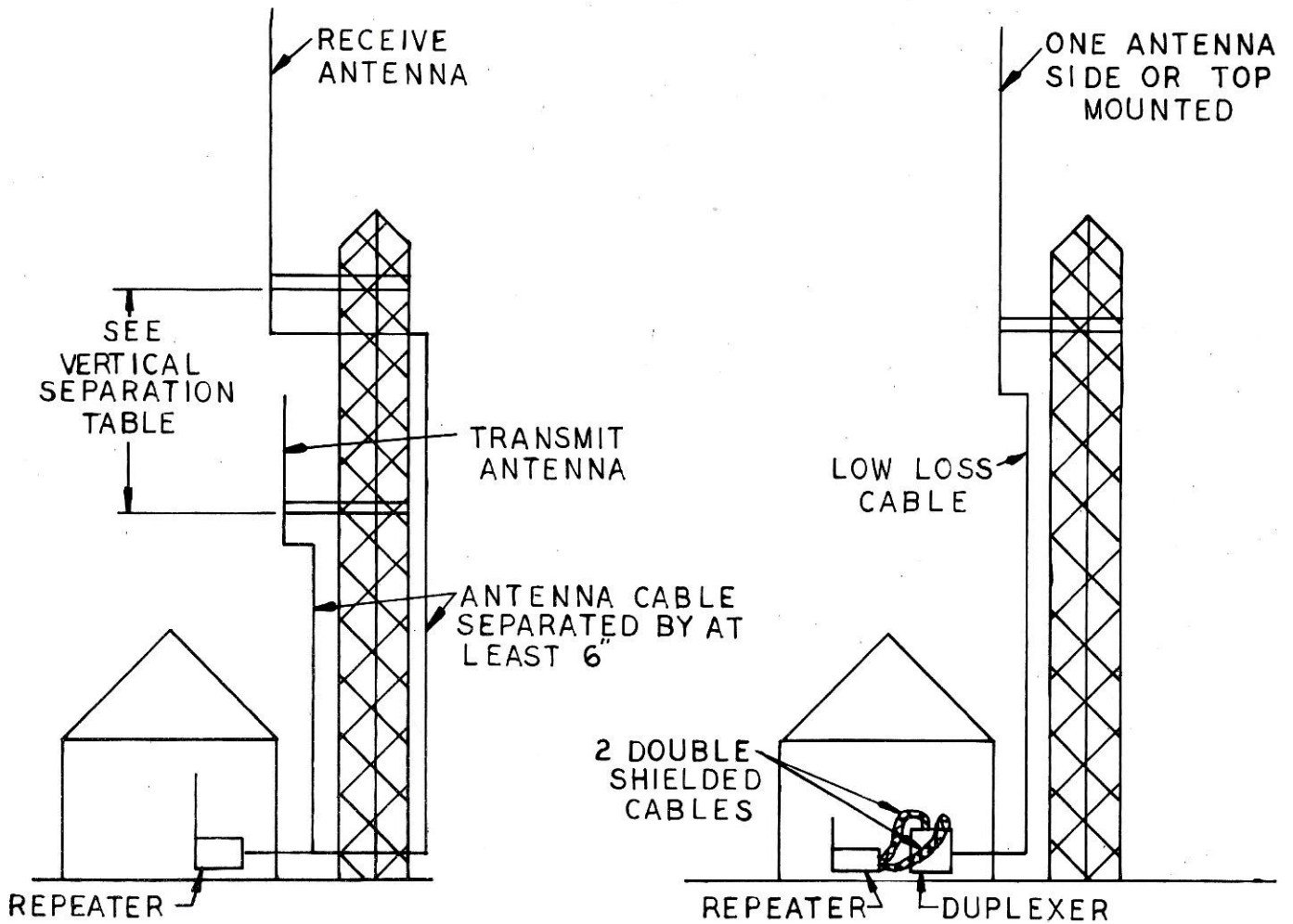

SEPARATE ANTENNA  
OPERATION

DUPLEXER  
OPERATION

TYPICAL REPEATER INSTALLATIONS

reading. This is the antenna isolation figure in dB. If the output level on the generator is calibrated only in uV, multiply the logarithm of the ratio of the two voltages by 20 to get the isolation in dB.

Under 175MHz the isolation figure may be improved by installing a piezoelectrical filter in the receive line. A piezoelectric filter (Piezo Technology Inc. Model 2133 VBP or equivalent) will add an additional 30dB to the antenna isolation figure. The piezoelectric filter will also improve intermod and receiver desense from strong adjacent signals.

High quality coaxial cable is an absolute requirement for proper operation of the repeater. For short runs or frequencies below 150MHz, a good quality RG-8/U is suitable. Low-loss hard-line is preferred for long runs and higher frequencies. All antenna connections must be thoroughly waterproofed. If separate antennas are used for receive and transmit, the cables should be separated throughout their run by at least 6-12 inches.

#### APPENDIX B - DUPLEXERS

The duplexer is used in repeater service to allow the use of a single antenna for reception and transmission. Using a single antenna for receiving and transmitting will help to equalize the repeater's receive and transmit range. The duplexer will provide over 80dB isolation of the receiver input from the transmit carrier and any sideband noise, while providing a low loss path for the transmit and receive signals. A bandpass - band-reject duplexer will help to eliminate desensing and intermod problems.

VHF Engineering can supply duplexers for all repeaters when they are required. Literature on the duplexers is available on request.

#### APPENDIX C - COMMON REPEATER PROBLEMS

##### DESENSE

One of the most frequent problems encountered in the operation of a repeater installation is desensing. This is caused by the transmit signal blocking the receiver. In severe cases this may cause a cyclic "chopping" of the repeater. Less severe desense is evidenced by an apparent drop in received signal strength when the transmit section of the repeater is activated. This can be easily checked on the repeater by switching from repeat to simplex mode and noting any difference in apparent received signal strength.

Desense is cured by increasing the isolation between the transmit and receive terminals. This is done by increasing the antenna separation or by adding band pass cavities, piezoelectric filters, or duplexers.

At certain frequencies, what may appear to be severe desense may be an image response to the repeater's transmit signal. The frequency of the image is dependent upon the location of the local oscillator frequency with respect to the receive signal frequency. This can be corrected by changing the frequency of either or both local oscillators, since it is possible to operate on either the plus or minus side of the signal frequency. If this should happen changing the 11.155 crystal to a 10.245 crystal will usually correct the problem. In some cases additional band pass cavities or piezoelectric filters in the antenna line may be needed.

#### INTERMOD (INTERMODULATION DISTORTION)

Intermod is characterized by the appearance of an unwanted or unexpected signal within the passband of the repeater receiver. One can usually identify a signal as being an intermod signal by the type of conversations taking place, by the presence of a distorted or off frequency signal, or by the presence of some signal that periodically causes the repeater to latch up. Intermod interference can be weak or strong, even to the point of covering up local signals.

Intermod interference is caused by two signals (usually strong), mixing in a non-linear circuit producing a third interfering signal. The non-linear circuit may be a transmitter output stage, a corroded antenna connector or more commonly a receiver front end.

The most common form of intermod interference is a strong signal, doubling in the receiver's mixer and mixing with a second signal to produce a product that is on or near the repeater's receive frequency. This product is commonly called 3rd order intermod. The relation between its frequency and that of the signals forming it is

$$f_{\text{IMD}} = 2f_1 - f_2; \text{ where } f_1 \text{ and } f_2 \\ \text{are the frequencies of the two signals.}$$

As an example, consider a receiver operating on 147.72 and nearby transmitters operating on 146.52 and 147.12

$$f_{\text{IMD}} = 2 \quad 147.12 - 146.52 = 147.72.$$

Since the repeater transmitter output is usually the strongest signal at the site, it's more apt to double in the receiver's mixer and cause a 3rd order intermod product with another strong in-band signal. This type of intermod is characterized by a signal which appears after the repeater is keyed up, and locks the repeater on. When the transmitter is turned off, the interfering signal goes away. This intermod interference never keys the repeater by itself.

This type of intermod can be cured by increasing the isolation between the RX and TX antenna terminals. This can be accomplished by increasing the antenna separation, installing a duplexer, or adding additional filtering in the receive line.

Intermod can also be caused by two strong signals from nearby transmitters mixing in the receiver's mixer. In this case, the interfering signal will key up the repeater. This can also be cured by adding a bandpass cavity filter, piezoelectric filter or using a bandpass - bandreject duplexer.

Intermod distortion can also occur in a transmitter output stage. This stage may be that of the repeater transmitter or a nearby transmitter. Usually the frequency doubled is the transmitter's output frequency, which together with an external signal, picked up by the transmitter antenna, forms a 3rd order intermod product. The local signals causing the intermod need to be quite strong due to the lack of gain in the transmitter's output stage.

Since this intermod product is formed outside the receiver and is within the receive band pass, it can't be filtered out in the receive antenna line. This type of interference can be eliminated by installing a circulator in the interfering transmitter's antenna line. A circulator allows power to pass in only one direction. This will prevent signals external to the transmitter from reaching its output stage.

Tracking down the cause of intermod can be a difficult or impossible task. The fact that intermod occurs is not necessarily the fault of the repeater, but is a matter of circumstances. In order for intermod to occur, there must be two signals present in some non-linear device.

In curing intermod, one simply has to remove or attenuate one of the interfering signals. Half of a solution is to find out what two signals are causing the intermod. The other half is to figure out the best way to eliminate one or both of the signals.

A good starting point is to use a good quality band pass - band reject duplexer like the VHF Engineering DPLA Series.

VHF Engineering does not market the piezoelectric filters or circulators. The filters may be obtained from:

Piezo Technology INC.  
P.O. Box 7877  
Orlando, Florida 32804

Circulators may be obtained from:

D B Products  
P.O. Box 47128  
Dallas, Texas 75247

Microwave Associates  
850A Stewart Drive  
Sunnyvale, CA 94086

## APPENDIX D - ACCESSORY INTERFACING

Interfacing of accessories (e.g. autopatch) is the responsibility of the customer. To aid in interfacing the following terminations are provided.

(refer to rear view pictorial diagram)

- 1.) KEY - Auxiliary push to talk input. A ground will key transmitter. All timers are bypassed.
- 2.) SPKR - Speaker output for remote monitor or phone patch connection. The signal is derived from the speaker output terminal.
- 3.) SPARE - no internal connection.
- 4.) P.T.T. - auxiliary push to talk input. This terminal may be externally grounded to key the transmit section of the repeater. Timer sequencing is initiated each time this terminal is activated.
- 5.) RELAY - provides external access to a normally open contact on the COR relay which is grounded when the transmit section of the repeater is activated. The maximum current handling capability of this contact is 3 amps DC.
- 6.) +12V SEE (7)
- 7.) +12V - this terminal is connected to the output of the internal 12 volt power supply. The internal supply may be adjusted to provide a trickle charge to a storage battery connected to this point. If the power failure occurs, the battery will then become the source of power for the repeater. The maximum current output available from this terminal is 3 amps.
- 8.) GROUND

EXTERNAL AUDIO JACK - used for connection of a phone patch, external voice I.D. etc. The input audio signal is coupled directly to the transmit audio line input. Normally, a 1 volt peak to peak signal will be sufficient to produce 5KHz deviation.

## APPENDIX E - SUPPLEMENTARY MANUALS

Manuals for receiver, transmitter, CWID, COR, power amplifier, and power supply models are included in this section.



# TECHNICAL BULLETIN

VOL I, No. 1

January 19, 1978

## BATTERY OPERATION OF REPEATERS

### BATTERY CHARGING USING PS-SERIES POWER SUPPLIES

The repeater instruction manual states that the +12V terminal on the rear of the repeater chassis may be used to trickle charge a storage battery connected to this point. In the event that a power line failure should occur, this battery will power the repeater.

IMPORTANT: A 3 amp fuse must be connected between the repeater +12V terminal and the battery positive terminal to prevent damage to the repeater and to eliminate a possible fire hazard in the event of a repeater component failure. If this fuse is not present, and a short circuit should occur within the repeater, full battery current will be routed through the repeater possibly causing severe damage to the repeater.

When using a PS series power supply to charge a storage battery, it is important to fuse the positive lead going from the PS series supply to the positive lead of the battery. The rating of the fuse should be equal to, or less than, the maximum current rating of the supply. Failure to fuse this lead may result in severe damage to the supply in the event of an internal component failure within the supply.

## PARTS IDENTIFICATION

In order to expedite delivery to you, we are occasionally forced to make minor substitutions of parts. For example; 4.7 MFD for 5 MFD; .022 MFD for .02 MFD. Such substitutions are carefully checked before they are approved and the parts supplied will function satisfactorily. These changes are usually self-evident and are mentioned here only to prevent confusion in checking the contents of your kit.

Each manufacturer seems to have his own method of marking for similar parts. In order to eliminate confusion about reading values marked on components, the following examples are presented.

**DISC CERAMIC CAPACITORS** - value and a tolerance letter printed on body. For example: 2.2C=2.2PF  $\pm$  1/4pf; 5D=5pf  $\pm$  1/2pf; 12J=12pf  $\pm$  5%; 680K=680pf  $\pm$  10%; 1000p=.001 Mfd; 104p=10000pf=.01 Mfd. Please **note** that the letters on capacitors do NOT denote a multiplier, they indicate tolerance only.

**SILVER MICA (SM) CAPACITORS** - value and tolerance are coded on the body of the device. For example: 220J03=22pf  $\pm$  5%; 330J03=33pf  $\pm$  5%; 221J03=220pf $\pm$ 5%; 331J03=330pf  $\pm$ 5%. Actual value may also be printed on the body. This should be self-evident.

**ELECTROLYTIC AND TANTALUM CAPACITORS** - the value is printed on the body of the device. There are several shapes and sizes the only odd one which we use is a tantalum which is shaped like a drop of water. **BE SURE THAT YOU OBSERVE POLARITY MARKINGS.**

**RESISTORS** - are color coded. Be very careful, when reading codes, not to confuse red and orange, brown and orange, violet and grey etc. When in doubt, check values with an ohmmeter.

**R. F. CHOKES** - read color code as follows:

1. Start reading from wide silver band.
2. The next group of bands indicate significant figures.
3. When a gold band appears in the significant figure grouping it should be read as a decimal point.
4. Last band indicates tolerance: gold=5% silver=10% None=20%

Examples:

wide silver/ gold/ orange/ orange = .33 uhy 20%

wide silver/ brown/ black/ black/ gold = 10 uhy 5%

wide silver/ blue/ grey/ brown/ gold = 680 uhy 5%

wide silver/ yellow/ gold/ purple/ silver = 4.7 uhy 10%

**COIL WINDING:** Follow our coil data exactly as given in the main part of this manual. When counting turns, be very careful to start with the first complete turn and not the second. For example: when a 3 1/2 turn coil is completed if you look at one side of the coil you will count 3 turns and looking at the other side you will count 4. **Be very careful to wind all coils in the same direction.**

- 1.) Assemble the RXCM package, following the instructions on the RXCM sheet included in this manual.
- 2.) Assemble the TA package, following the instructions on the TA sheet included in this manual.
- 3.) Assemble the PS, COR, and CWID modules according to their instruction sheets.
- 4.) Mount the heat sink to the back panel, as shown, with two 8-32 X 3/4 screws and 8-32 X 1/4" nuts. Make sure the holes in the heat sink line up with the holes in the chassis. Slip a grey insulator onto the pins of each 2N3055 (NOTE: These insulators do not need to be coated with silicon grease). Install the four pieces of teflon tubing into the heat sink, one in each pass transistor screw mounting hole. Carefully plug the transistors through the heat sink into a socket held on the inside. Be sure to orient the transistors so that the pins are centered in the holes of the heat sink and the positioning holes of the sockets line up properly. Secure the entire assembly using the #6 self tapping screws.
- 5.) Mount the front panel to the main chassis using the controls, mike jack, pilot light and handles as shown on the drawing. Align the ON/OFF and SIMPLEX/RPT switches as shown.
- 6.) Install the accessory terminal strip and cable clamp with 8-32 X 3/4" screws, washers and nuts as shown on the drawing. Install the audio jack and fuse holder. Install the LM309 regulator with a socket and 2 #6 self tap screws. Be sure to coat the bottom of the regulator with silicon grease. Install the stand-off insulator near to the pass transistors with a 4-40 X 1/4" screw as shown.
- 7.) Generously coat the bottom of the bridge rectifier with silicon grease. Install as shown in the drawing with an 8-32 X 3/4" screw, washer, and nut. Install the six grommets as shown.
- 8.) Mount the COR board with 3/4" standoffs and 4-40 X 1/4" screws and lock washers. Mount the terminal strip as shown.
- 9.) Mount the CWID board with four 3/8" standoffs and 4-40 X 1/4" screws and lock washers.
- 10.) Mount the power transformer and condenser brackets with four 10-32 X 1/2" screws, washers and nuts as shown. Slip the filter condenser into place before tightening the screws. Be sure the condenser is lined up so the positive connection is towards the front of the chassis.
- 11.) Mount the RXCM and TA packages using 4 X 40 X 3/8" screws, lockwashers and nuts.

- 12.) Install and solder a .1 ohm 5 watt resistor from each pass transistor emitter lead to the standoff insulator as shown on the drawing.
- 13.) Lay the wiring harness into place as shown in the drawings. Mount the PS-3 on the large filter capacitor using two 10-32 X 3/8" screws. One screw through the lug on the orange wires to the plus terminal, and one through the lug on the black wires to the negative terminal. Bolt the solder lug with three black leads to the accessory terminal strip as shown.
- 14.) Push the shielded cable, white #22 wire and orange #18 wire through the grommet near the pass transistors. Push the brown #22 wire and white #22 wire through the grommet near the LM309 regulator. Push the #14 black wire through the grommet near the accessory terminal block.
- 15.) Remove  $\frac{1}{2}$ " of insulation about 3" from the end of the #14 orange wire and #18 green wire near the pass transistor by sliding the insulation with wire strippers. Strip the ends of both wires back  $\frac{1}{2}$ ". Connect these wires to both transistors as shown on the drawing and solder.
- 16.) Connect and solder all the remaining wires in the harness under the chassis as shown in the drawing. The wires which were pushed through grommets will be connected later.
- 17.) Mount a solder lug to the COR switching transistor with a 4-40 screw and nut. Connect it to the PTT terminal on the mike jack with a 5" piece of white #22 wire and solder both ends.
- 18.) Connect a 6" #18 red wire between the junction of the .1 ohm resistors and 12 volt terminal on accessory terminal strip and solder both ends. Solder a 4" #18 red wire to the input of the LM309 regulator. Pass the wire through the grommet to the receiver 12 volt feed-through filter and solder.
- 19.) Install a 3 amp reverse protection diode and 470 MFD capacitor between +12VDC and ground terminal on the rear 8 pin accessory strip and solder as shown.
- 20.) Install OVP with black lead to the ground terminal and red lead to +12 terminal and solder as shown.
- 21.) Connect a 5" #22 brown wire between the RPT level and RPT LOCAL level controls as shown and solder both ends.
- 22.) Connect the ground end of the RPT-SIMPLEX switch, mike jack, LOCAL RPT level controls and pilot light together with black #18 wire. Connect a short piece of black #18 wire from the ground end of the RPT LEVEL control to the ground lug on the terminal strip and then to the COR as shown. Solder all connections.

- 23.) Solder a 8" green wire and 8" black wire to the LOCAL LEVEL control as shown. Push the loose ends through the grommet next to the COR. Solder the black wire to the grounded speaker lug and the green wire to the other speaker lug.
- 24.) Connect three 4.7K  $\frac{1}{4}$  watt resistors to the terminal strip and LOCAL LEVEL control near the COR board as shown. Solder all connections.
- 25.) Solder the orange #18 wire, white #22 wire, and coax cable to the TX feed throughs as shown. Solder the white #22 wire and brown #22 wire to the RX feed throughs as shown.
- 26.) Feed the secondary leads through the rubber grommet near the transformer. Solder one of the secondary leads on the power transformer to one of the terminals marked "AC" on the bridge rectifier. Now solder the other secondary lead to the remaining lug marked "AC" on the bridge rectifier.
- 27.) Strip back the rubber jacket on the power cord about 6". Push the cord through the grommet and cable clamp as shown. Solder the black lead to the fuse holder, the green lead to ground, and run the white lead through the grommet near the transformer. NOTE: FOR 110V OPERATION: Cut and strip two 2" pieces #18 brown wire. Connect one wire from the primary terminal #1 to terminal #3. Connect the other wire from terminal #4 to terminal #2. Solder pins 2 and 3 only. FOR 220V OPERATION: Cut and strip one 1" piece of #18 brown wire. Connect one end to primary terminal #2 and the other end to terminal #3 power transformer. Solder both connections. Feed the white lead from power cable and black lead from the harness through the rubber grommet at the rear of the chassis. Connect white wire to terminal #1 and black to terminal #4.
- 28.) Check all wiring for shorts and proper connections.

NOTE: BEFORE APPLYING POWER, TURN THE VOLTAGE CONTROL POT ON THE PS REGULATOR CARD FULL CW AS VIEWED FROM THE FRONT OF THE REPEATER. IF POWER IS APPLIED WITH THE POT SET TO HIGH, THE OVP WILL TRIP, SHUTTING DOWN THE SUPPLY. TO RESET, REMOVE POWER AND ADJUST VOLTAGE POT TO A LOWER VOLTAGE.

# RX-CM

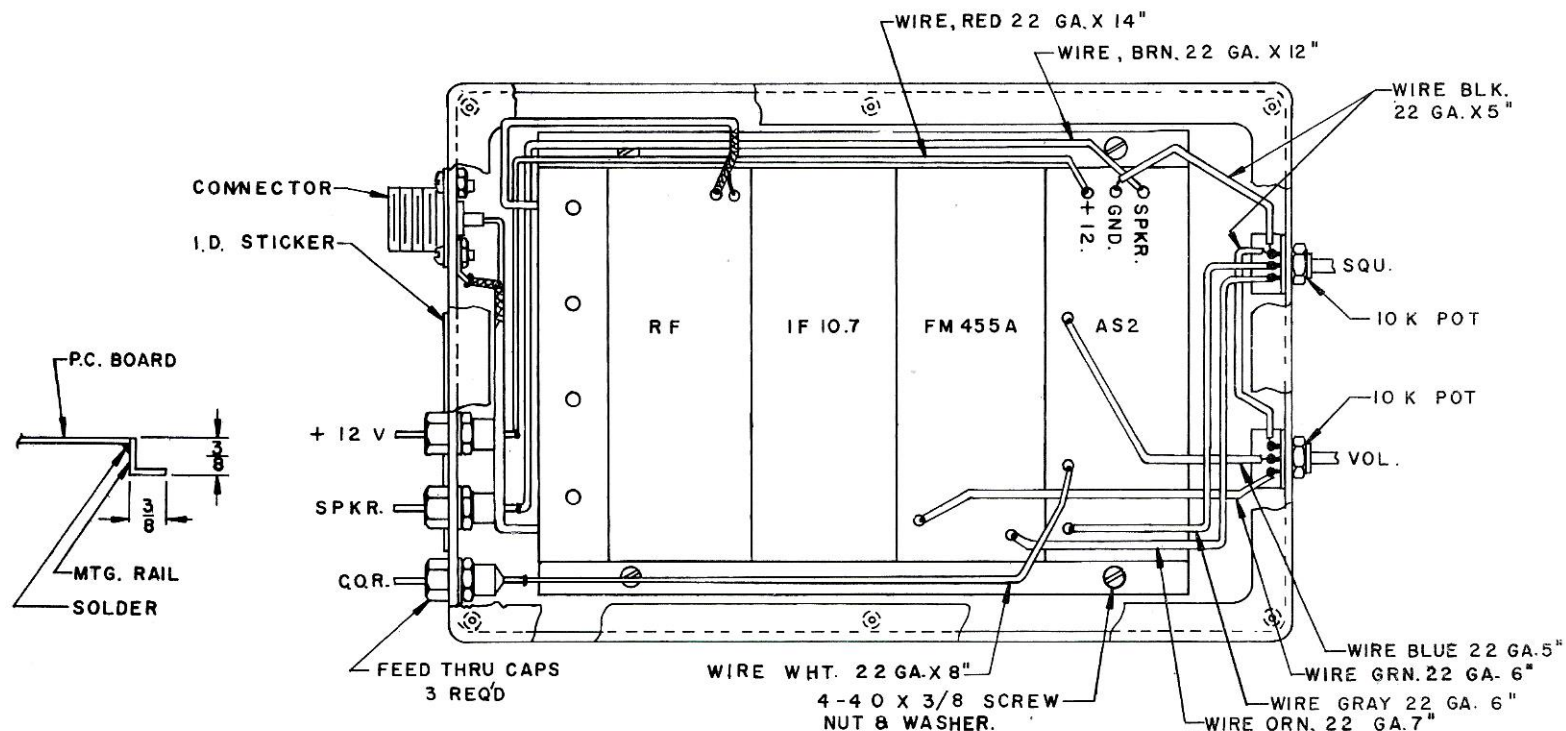

1.) Build the RX modules according to their respective instructions. Carefully check each module for bad solder connections and wiring mistakes.

2.) Mount the four receiver boards to the rails as shown above, leaving the excess length of rail extending out from the RF board. Solder the entire length of the rail.

3.) Install the jumper wires between the modules as shown in the receiver manual. Wire the volume and squelch controls as shown above.

4.) Test and align the receiver following the procedure in the manual.

5.) Mount the coax connectors with the 4-40 hardware provided. Mount the feed through condensers with the lock washer and nut inside the box.

6.) Place the helical resonator flush with the end of the RF board (leads side away from receiver) making sure to align the base of the helical resonator with the base of the mounting rails. Solder to edge of rails. Connect one coax lead to the antenna input connection (shield to ground) on the RF board.

7.) Center the receiver inside the box. Locate and mark the mounting holes with a scribe. Drill all four holes 1/8" diameter. Mount the receiver with 4-40 hardware.

8.) Clip off the locating pin on the squelch and volume controls. Mount each control with a lock washer between it and the box.

9.) Realign the receiver and helical resonator for maximum sensitivity. The four stages of the resonator are peaked for maximum received signal on the operating frequency. NOTE: There is some interaction between stages of the helical resonator. This requires the repeaking of the four stages until no further improvement is noticed.

# TA

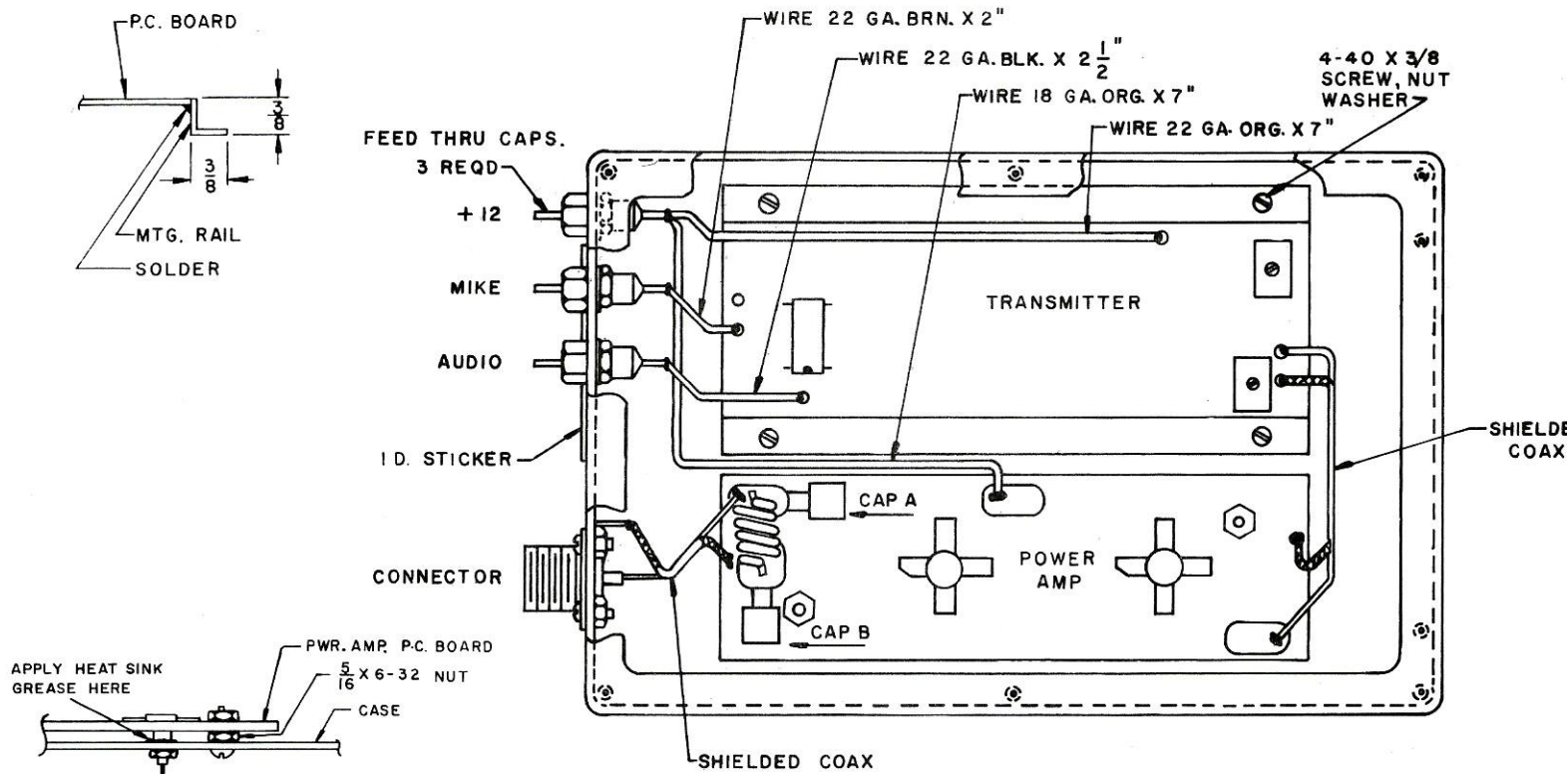

- 1.) Build the TX module according to the instruction sheet enclosed. Carefully check the board for bad solder connections and wiring mistakes. Mount the TX module on the rails as shown. Solder the entire length of the rails. Drill four 1/8" mounting holes in the rails as shown.
- 2.) Mount the TX, feed through filters, and connector as shown.
- 3.) Mount the PA circuit board inside the TX box using two 6-32 nuts as spacers between the board and the case. Coat the flanges of the transistors with silicon grease before mounting. Do not overtighten the transistor nuts.
- 4.) a. Wire the PA according to the instructions enclosed. Install an additional output filter as shown in the drawing above.

140-160 MHz:

4 turns #14 Silver Plated 1/4" I.D.  
2 - 22pf Uncased Mica Capacitors (A,B)

210-230 MHz:

3 turns #14 Silver Plated 1/4" I.D.  
2 - 15pf Uncased Mica Capacitors (A,B)

430-470 MHz:

1 turn loop #14 1/4" I.D. 1/2" long  
2 - 7pf Uncased Mica Capacitors (A,B)

- b. Install interconnection wiring as shown in the drawing above.

- 5.) Align according to the TX and PA manuals. It is recommended that the TX be aligned first with a dummy load, then with the PA connected for final alignment.

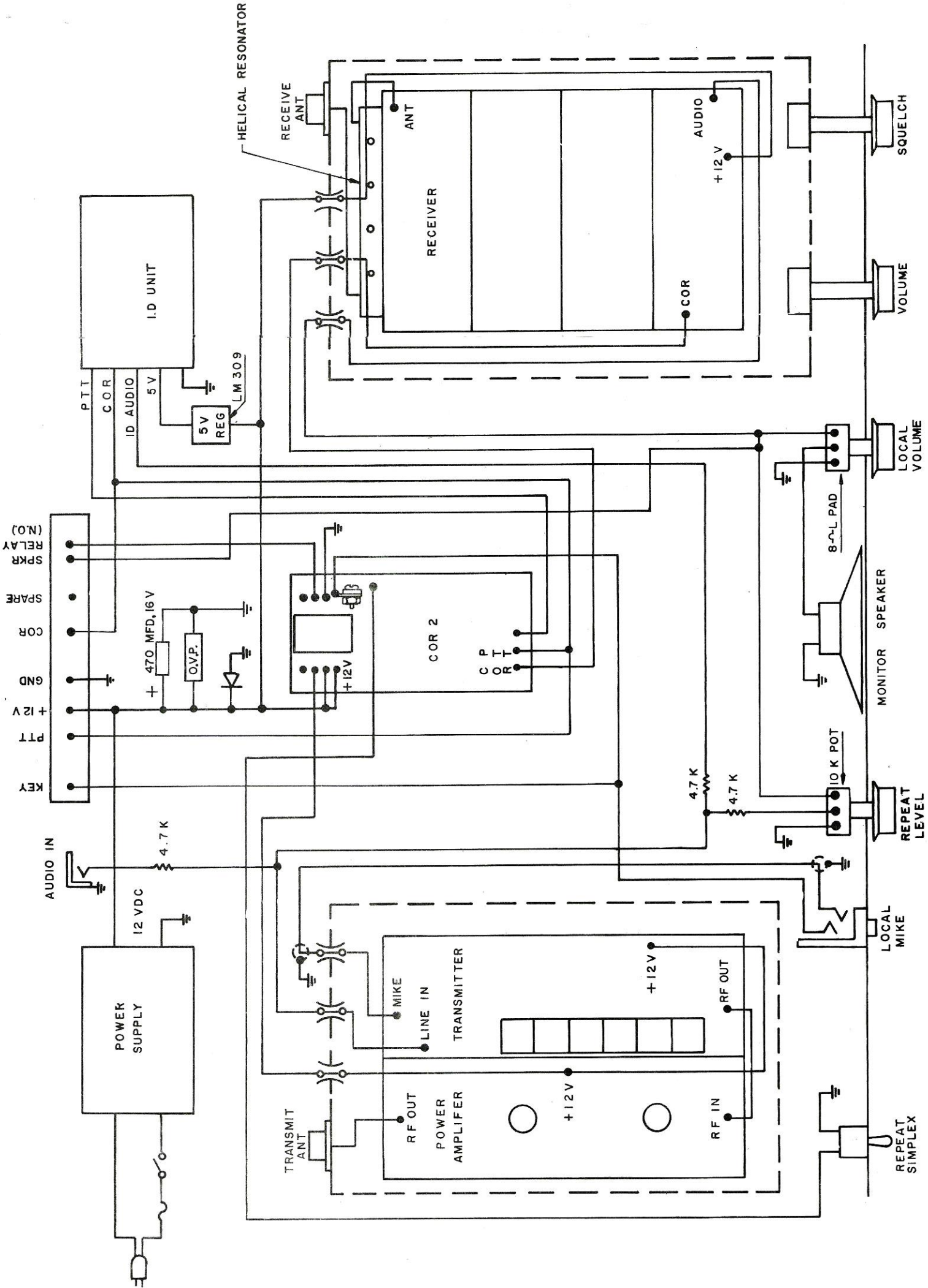

TYPICAL REPEATER SYSTEM



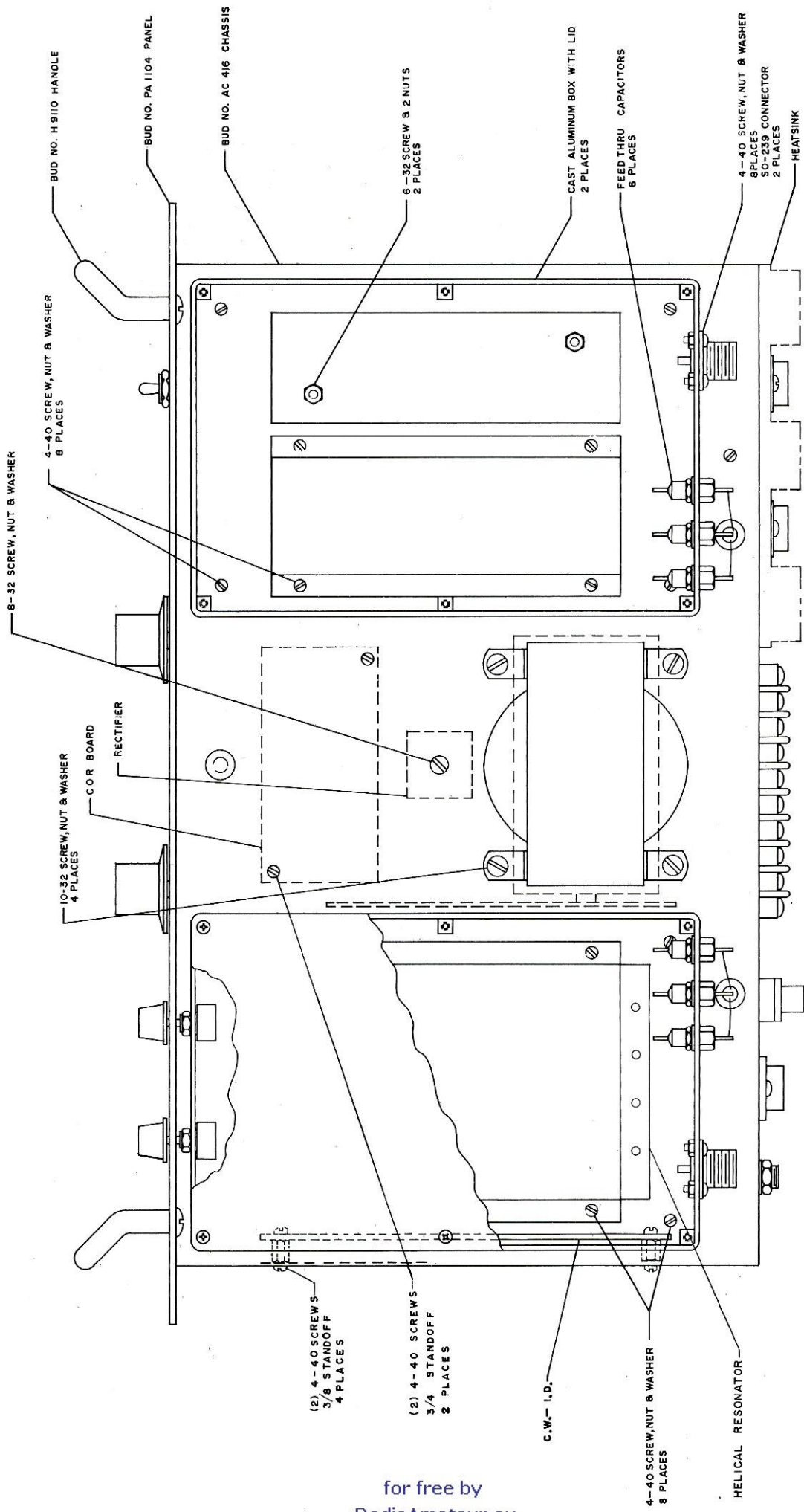

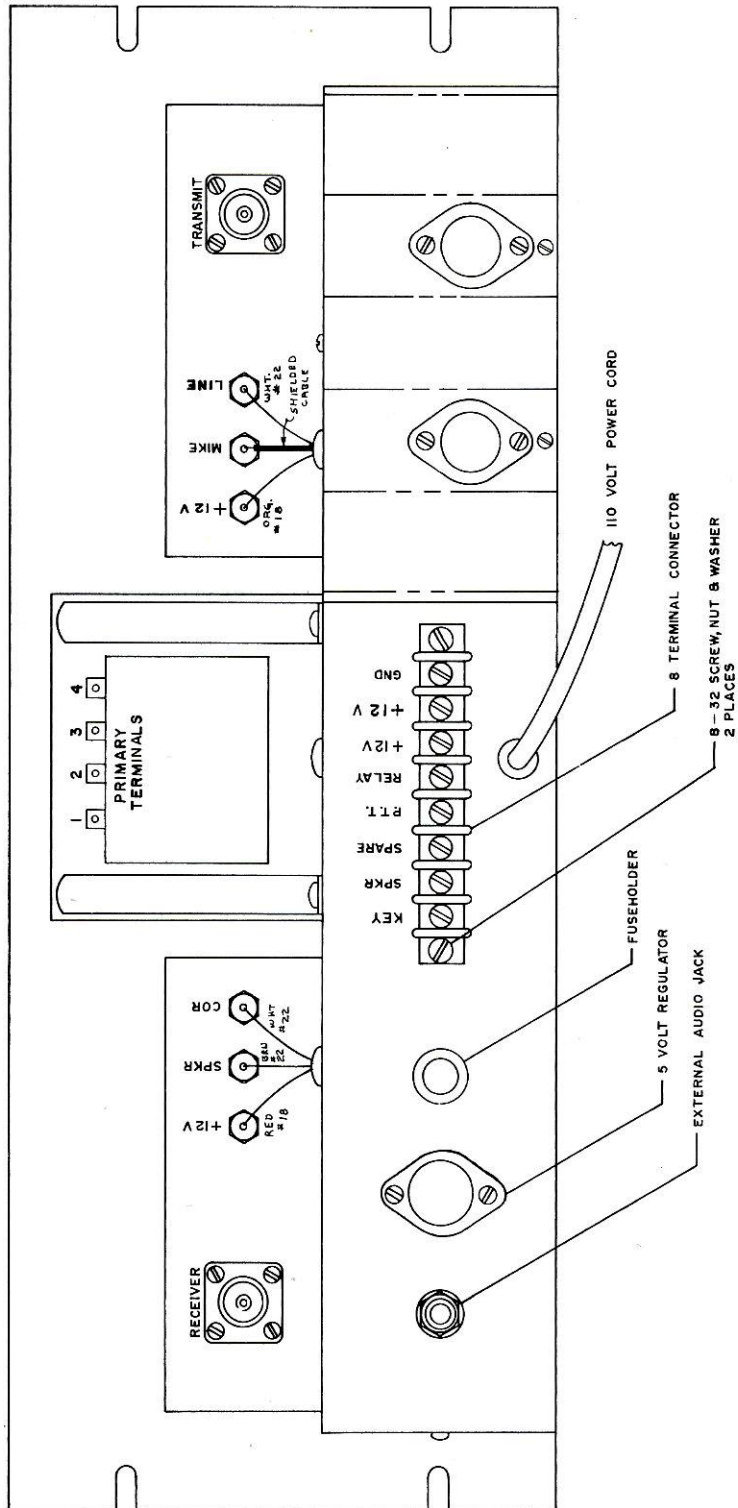

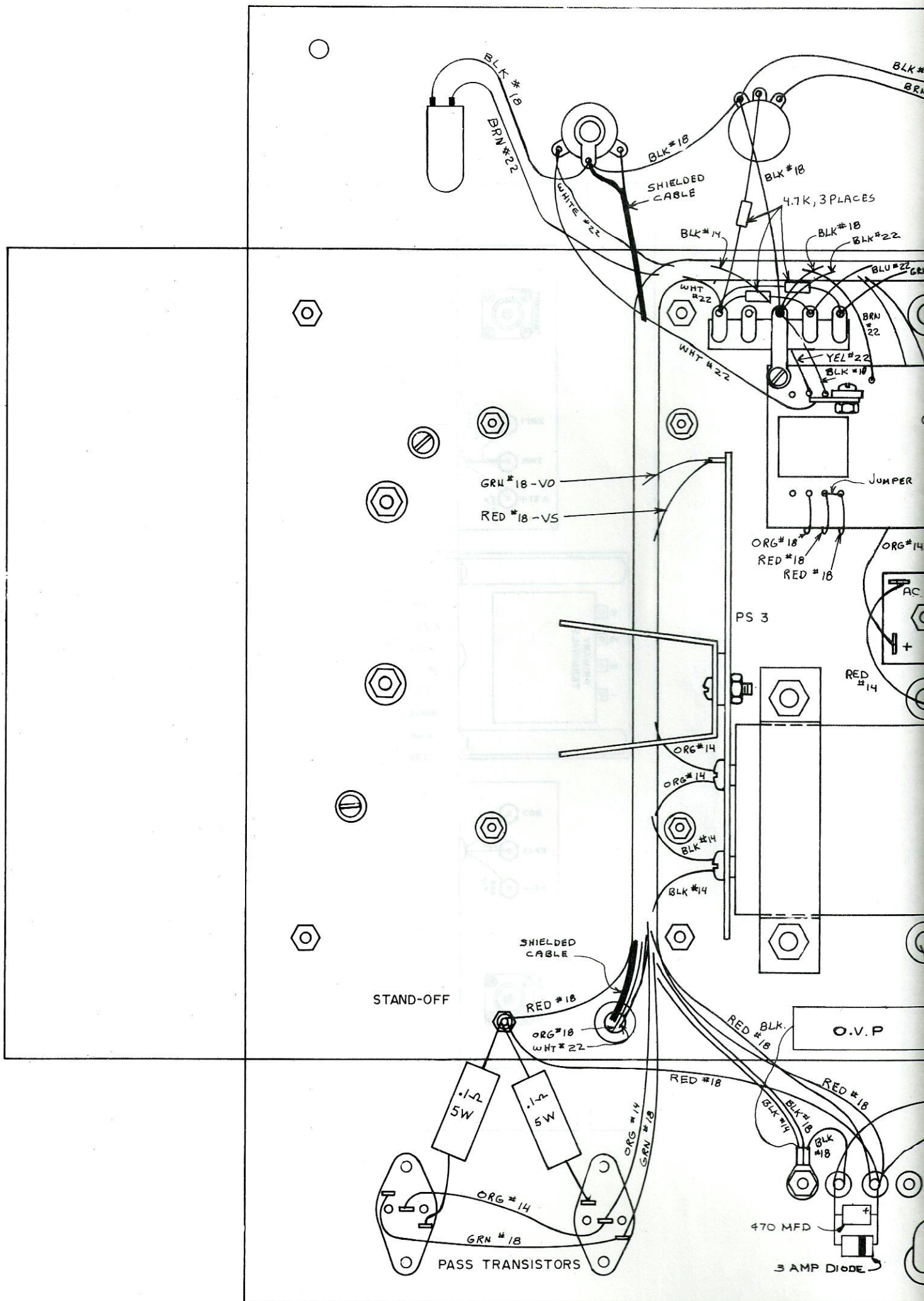

BLK #18  
BRN #22

SHIELDED CABLE  
4.7K, 3 PLACES  
BLK #18  
BLK #22

GRN #18 - VO  
RED #18 - VS

ORG #18  
RED #18  
RED #18

PS 3

O.V.P

STAND-OFF

SHIELDED CABLE

.1Ω  
5W  
.1Ω  
5W

PASS TRANSISTORS

470 MFD

3 AMP DIODE

AC  
+

RED #14

ORG #14

BLU #22  
GRN #22

BRN #22

BLK #18  
BLK #22

BLK #14

SHIELDED CABLE

WHT #22

WHT #22

BLK #18

BLK #18  
BRN #22

WHT #22

JUMPER

WHT #22

YEL #22

BLK #18

WHT #22

ORG #14

ORG #14

BLK #14

BLK #14

RED #18

ORG #18  
WHT #22

RED BLK #18

RED #18

ORG #14  
GRN #18

RED #18

BLK #14  
BLK #18  
BLK #18

RED #18

ORG #14

GRN #18

