

# RE-301

# SERVICE NOTES

SECOND EDITION

## 1. SPECIFICATIONS

### 1-1. INPUT

	Impedance	Sensitivity*
-50dB	3K $\Omega$	3.2 (2.8) mVrms
-35dB	56K $\Omega$	17.8 (12.5) mVrms
-20dB	56K $\Omega$	100 (58) mVrms

\*With 1KHz sine wave input, to obtain 0 VU, slightly over which Peak Level Lamp lights up. Figures in parenthesis indicate sensitivity for Serial No. Up to 621849.

### 1-2. OUTPUT

	Level	Impedance (Approx.)	
		Connected to both A and B Jacks	Connected to A Jack alone
H: -15dB	88mVrms	5K $\Omega$	2.5K $\Omega$
M: -25dB	27mVrms	1.5K $\Omega$	0.75K $\Omega$
L: -35dB	9mVrms	0.5K $\Omega$	0.25K $\Omega$

\*Input: 1KHz sine wave, 3.2mVrms, with Input Level switch at -50dB.  
 Setting: All effects - off, Direct signal - on  
 Output: No load, from A Jack

### 1-3. TONE CONTROL

Input	3.2mVrms sine wave, Input Level at -50dB			
	600Hz		6KHz	
BASS	MAX	MIN	CENTER	
TREBLE	CENTER		MAX	MIN
Output	240mV	7mV	150mV	7mV
	No load, from A Jack			

### 1-4. DELAY TIME

	Repeat Rate	Mode 1 PH-1	Mode 2 PH-2	Mode 3 PH-3	Sound on Sound PH-4
ECHO	Max.	40ms	80ms	210ms	10s
	Center	60ms	120ms	320ms	15s
	Min.	130ms	260ms	720ms	35s
CHORUS	Intensity	Delay Time			
	Min.	2ms			
	Max.	12ms			

### 1-5. OTHERS

- Power consumption ..... 22W
- Dimensions ..... 415(W) x 190(H) x 300(D)mm
- Weight ..... 10kg

## 2. DISASSEMBLY AND UNIT LOCATION

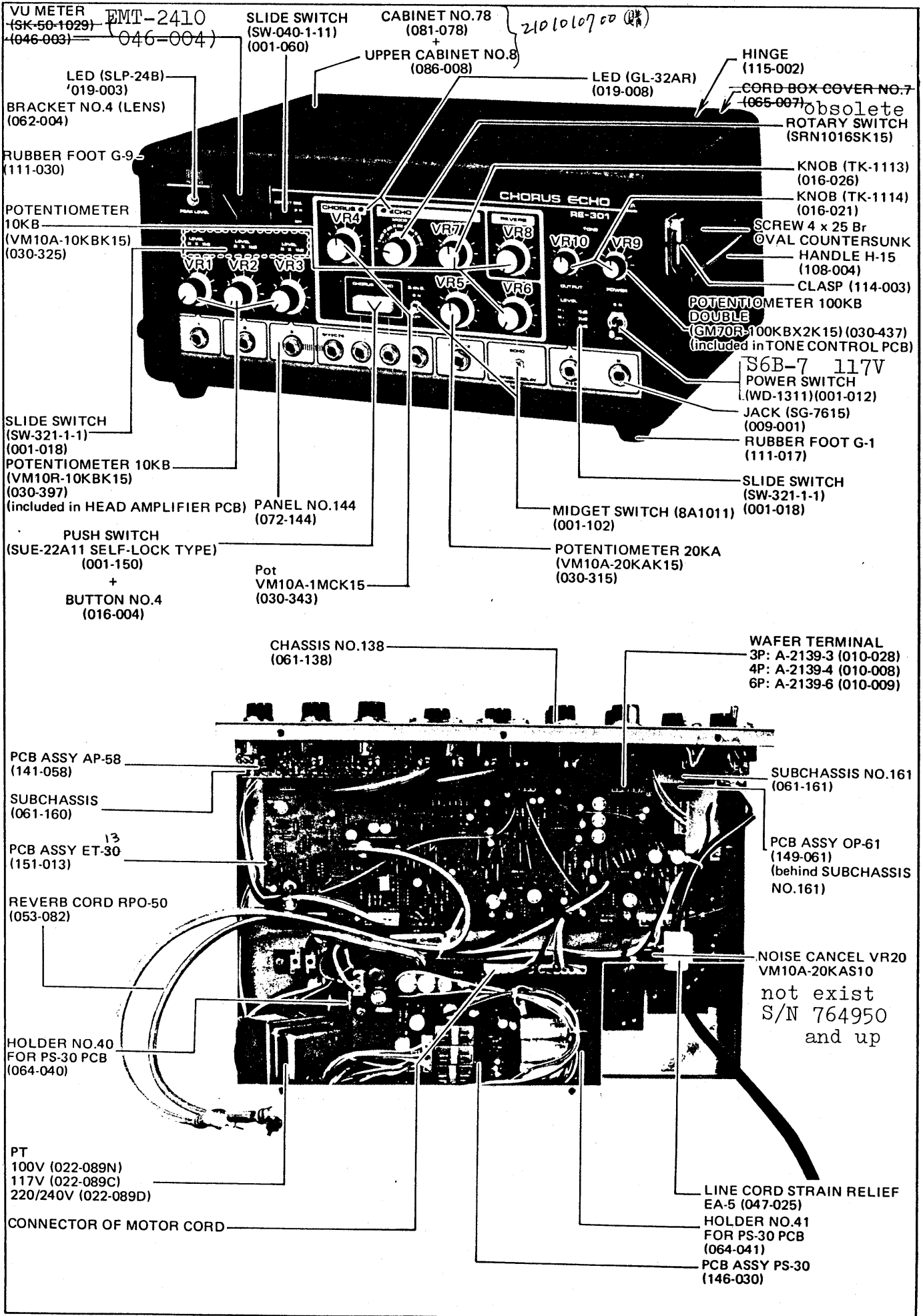

WAVEFORM CHART . . . . WITH 3.8mV (approx. 9mVp-p), 1KHz SQUARE WAVE INPUT

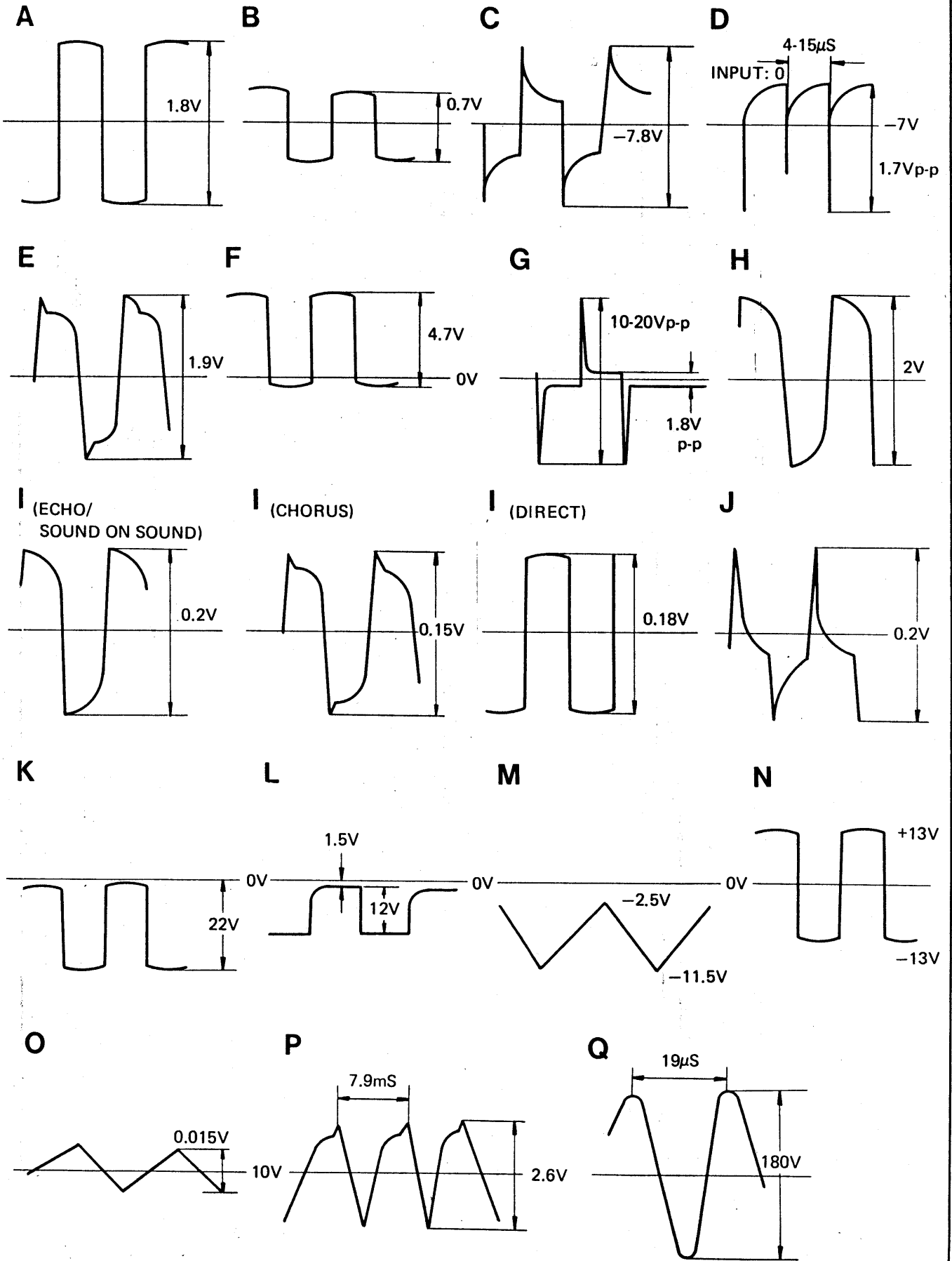

# 4. BLOCK DIAGRAM

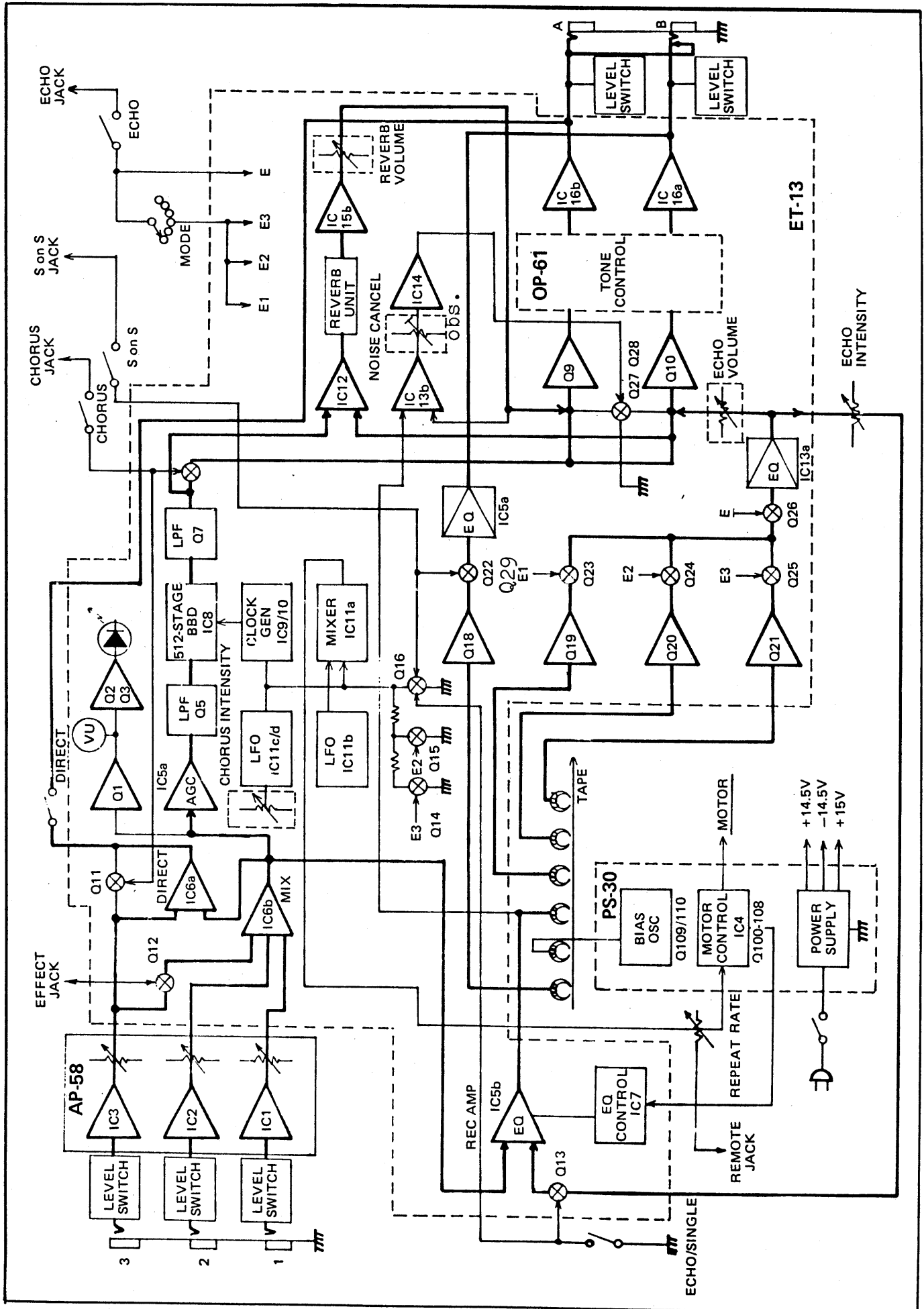

## 5. CIRCUIT DESCRIPTION

RE-301 produces (1) Direct sound, (2) Echo and Sound on Sound sounds by tape mechanism, (3) Chorus sound by BBD and (4) Reverb sound by spring. The unit comprises circuits to produce the above sounds and auxiliary circuits like motor circuit and power supply circuit. Most of the control of these circuits and switching of signals are processed by DC voltage, which serves to reduce the number of signal wiring, resulting in great improvement in signal-to-noise ratio and hum level.

### 1ST PREAMPLIFIER (AP-58)

The input signal is attenuated by changing the feedback in IC1, IC2 and IC3 and also by changing the input impedance. At  $-20\text{dB}$  and  $-35\text{dB}$  input level switch positions, impedance is high and at  $-50\text{dB}$ , impedance is low.

### MIXER & DIRECT SOUND AMPLIFIER (IC6)

Output signal from AP-58 is mixed by Mixer IC6b and the mixed signal is amplified by IC6a to become Direct sound signal. The mixed signal is also fed to successive effect circuits. When EFFECT is cancelled through EFFECTS CANCEL REMOTE jack, Input No.3 is connected to Direct Sound Amplifier IC6a alone. Q11 reduces Direct Level when Chorus is ON.

### PEAK LEVEL INDICATOR

Comparator Q2 and Q3 operates with sine wave of the level where VU meter indication exceeds 0, making LED conductive to light up.

### CHORUS CIRCUIT

Automatic Gain Control & Low-Pass Filter

In order to prevent excessive amplitude signal from being applied on BBD (IC8) that may cause distortion, Automatic Gain Control IC5a controls the signal below the permissible input level of BBD.

Low-pass filter comprises Q5 and C & R's, and attenuates the frequencies of input signal which may cause beating by interference with clock frequency.

### BBD CLOCK GENERATOR

Clock leakage in the output signal of BBD IC8 is decreased by VR13 and subsequent low-pass filter comprising Q7 and C & R's.

Clock generator IC9a, 9c and 9d generates  $45\text{K} - 250\text{KHz}$  frequency, while being modulated by LFO IC11c. And the output is frequency-divided to approximately  $20\text{K} - 130\text{KHz}$ , by the subsequent Flip Flop IC10, to become clock pulses of opposite polarity to operate BBD.

### ECHO CIRCUIT

Recording Amplifier & Equalizer

In order to improve signal-to-noise ratio, higher frequency is pre-emphasized in recording amplifier IC5b.

On the other hand, recording frequency response changes in accordance with the change in tape speed. To compensate for this change, the capacitance of IC7 which demonstrates capacitor character is changed by the voltage that is proportional to motor speed, causing change in equalizer curve.

Playback equalization (de-emphasis) is made by IC13a. But equalization for sound-on-sound playback is made exclusively by IC15a.

### MOTOR DRIVE

Motor drive circuit comprises Q100 - 108 and IC4b on PS-30. Output voltage from IC11a on ET-13 is changed by Repeat Rate control VR5. This voltage is compared by IC4b with the voltage proportional to motor speed. The difference is applied on Q108 to control the power applied on the motor.

In order to obtain natural echo effect through adequate motor revolution, LFO outputs are mixed by IC11a and added on the control voltage. The voltage differs for each of playback head. At Chorus effect, outputs from two LFO's are added to IC11a.

IC4a produces DC voltage that is proportional to motor speed and it is applied to the recording equalizer control circuit mentioned above.

### NOISE CANCEL CIRCUIT

Q27 and Q28 conduct when input signal is very low and any noise that is generated in the preceding circuits are grounded.

With signal exceeding the noise level, the minus voltage from IC14 is cut off to pass the signal.

# 6 MAIN BOARD ET-13 (151-013)

2nd (May 30, 1979) JUN 30 1977 RE-301

Serial No. up to 764799

### NOTE:

For Serial No. 611400 and higher, Non-Polar Capacitors (formerly Electrolytic) are used for: C2, 4, 22, 41, 43, 44, 54, 59, 64, 65, 68, 69, 70, 73, 80.

PARTS attached on foil side:

R166  
R167

C82  
C92  
C93  
C86  
C87  
C88  
C89  
C85  
C81  
C90  
C91

VR15  
P1 level  
VR16  
P2 level  
VR17 P3

WAFER TERMINAL  
A-2461-4C  
(010-030)

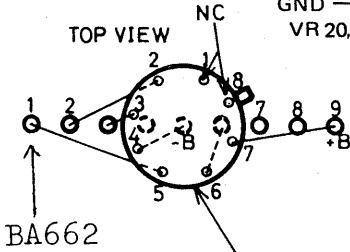

BA662

pins connection

CA3080A  
BA662

see page 9

IC7: CA3080A

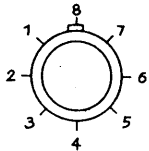

TOP VIEW

J6  
J5  
GND  
SW4, CT  
VR8, No.2  
VR7, No.2

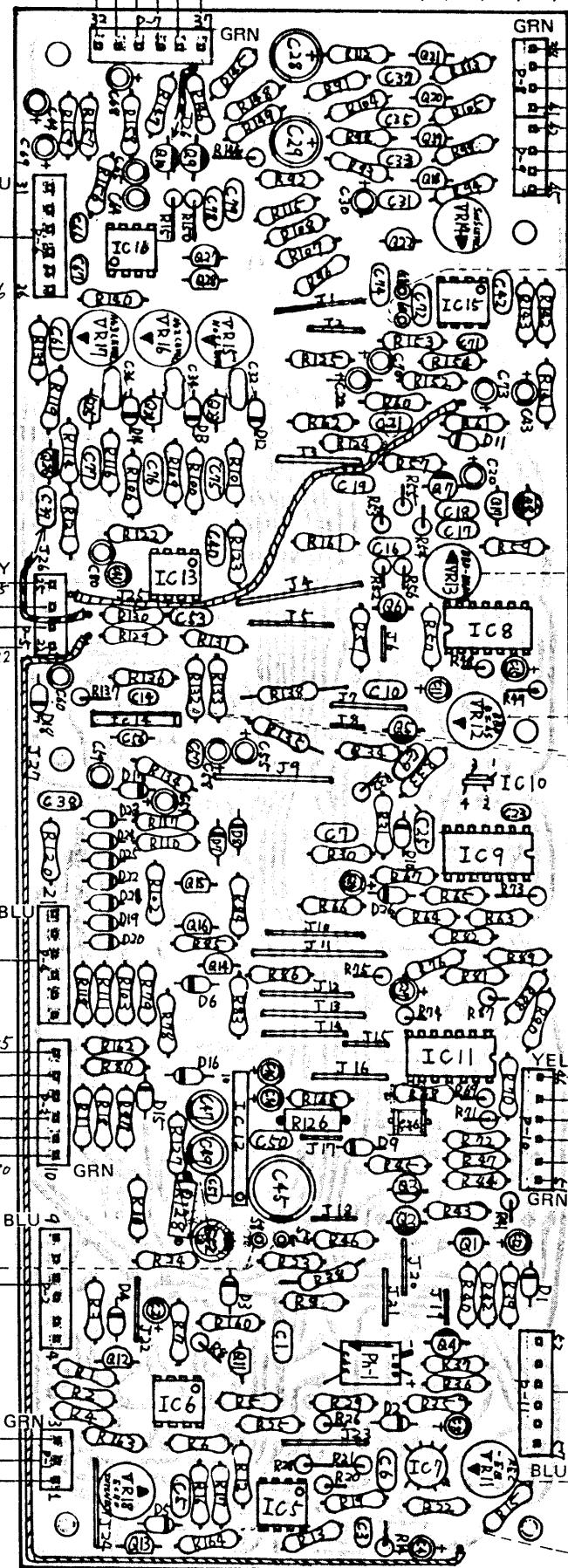

GRN  
38  
GND  
PH3  
PH2  
GND  
PH1  
GND  
PH4  
GND  
45

REVERB UNIT OUTPUT

CLOCK BALANCE

BBD BIAS ADJ

Can be replaced by ET-13A. When VR-20 is left effective, R132 on ET-13A should be the same as is on ET-13 ( in value, in connection).

J4  
VR4, No.3  
VR4, No.2  
LED1  
GND  
VU METER (+)  
GRN

PS-30

REC-EQ ADJ

BIAS TRAP CHECK POINT

SW4, No.2  
GND  
VR6, No.2  
A2461-3C  
(010-035)

MAY 30 1979

6-1 MAIN BOARD ET-13 A (151-013A)

Serial No.764800 and higher

Can replace ET-13 see note below.

IC8: MN3004 IC9: CD4001UBE

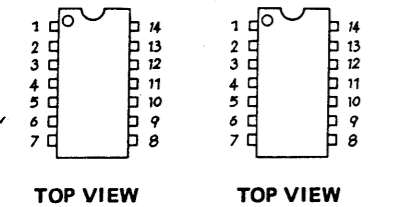

IC12: TA7200P IC14: TA7136P

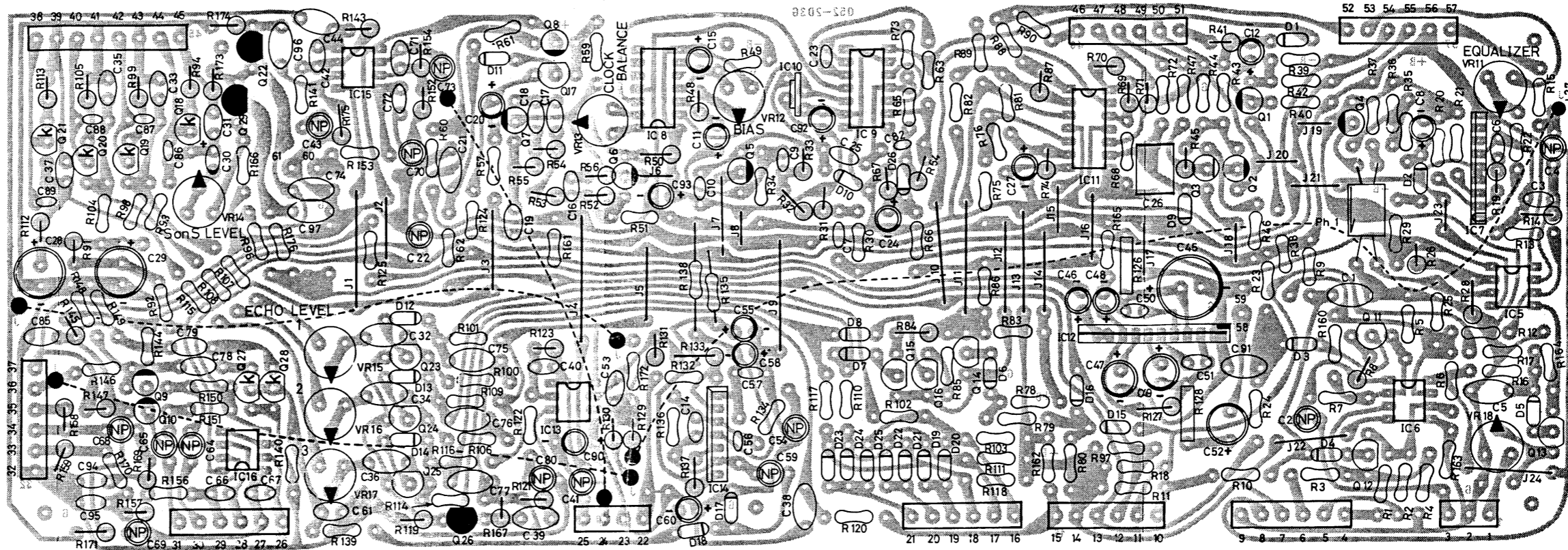
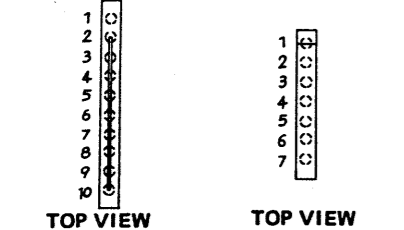

IC'S  
IC5, 6, 13, 15, 16:  
JRC4558D (NJM)  
μPC4558C (NEC)

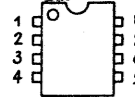

TOP VIEW

IC10: DN819 IC11: μPC324C



TOP VIEW

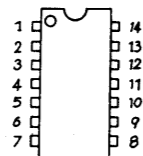

TOP VIEW

Circuit improvements and Component changes

Serial No. 764800

PCB Assy change,- ET-13 to ET-13A  
interchangeable, but care should be  
taken if NOISE CANCEL,VR20 is needed  
- refer to below.

S.on. S. add,- FET switch Q29, 2SK30A-Y  
change,- Q22, 2SK68 to 2SK30A-Y  
change,-EQ circuit (RC constant)

OUTPUT add,- LPF

IC7 change,- 3080A to BA662  
3080 is not in production  
interchangeable with proper connection  
of pins.

2SC100GR replace,- by 2SC732TM-GR  
interchangeable

Serial No.764950 - 805699

NOISE CANCEL  
Variable to Fix resistor  
VR20 to R168, 18k-ohm

S/N No.805700 -  
R168(obs.) to R132(1k to 2.2k)

LEVEL METER

S/N No. 785450 -  
change,- BK-560(SK-50) to EMT-2410  
compatible

IC CD4001BE

change,- to CD4001UBE or TC4001UBP  
CD4001BE with internal buffer for  
output gate

CD4001UBE without buffer

Using CD4001BE in CLOCK GENERATOR  
may result in no oscillation.

NOTE: To replace ET-13 with ET-13A,  
R132 (2.2K) should be changed  
to 1k with one end connected  
to pin 22 if VR-20 left  
effective.

- : Q18 - 21, Q27, Q28 2SK68A-K
- : Q26, Q22, Q29 2SK30A-Y
- : Q1, Q2, Q4 -10 2SC732TM-GR

- : Q3 2SA733-P or Q
- : Q11 - 17, Q23 - 25 2SK68A-K or L, M, N
- : Diode 1S1588

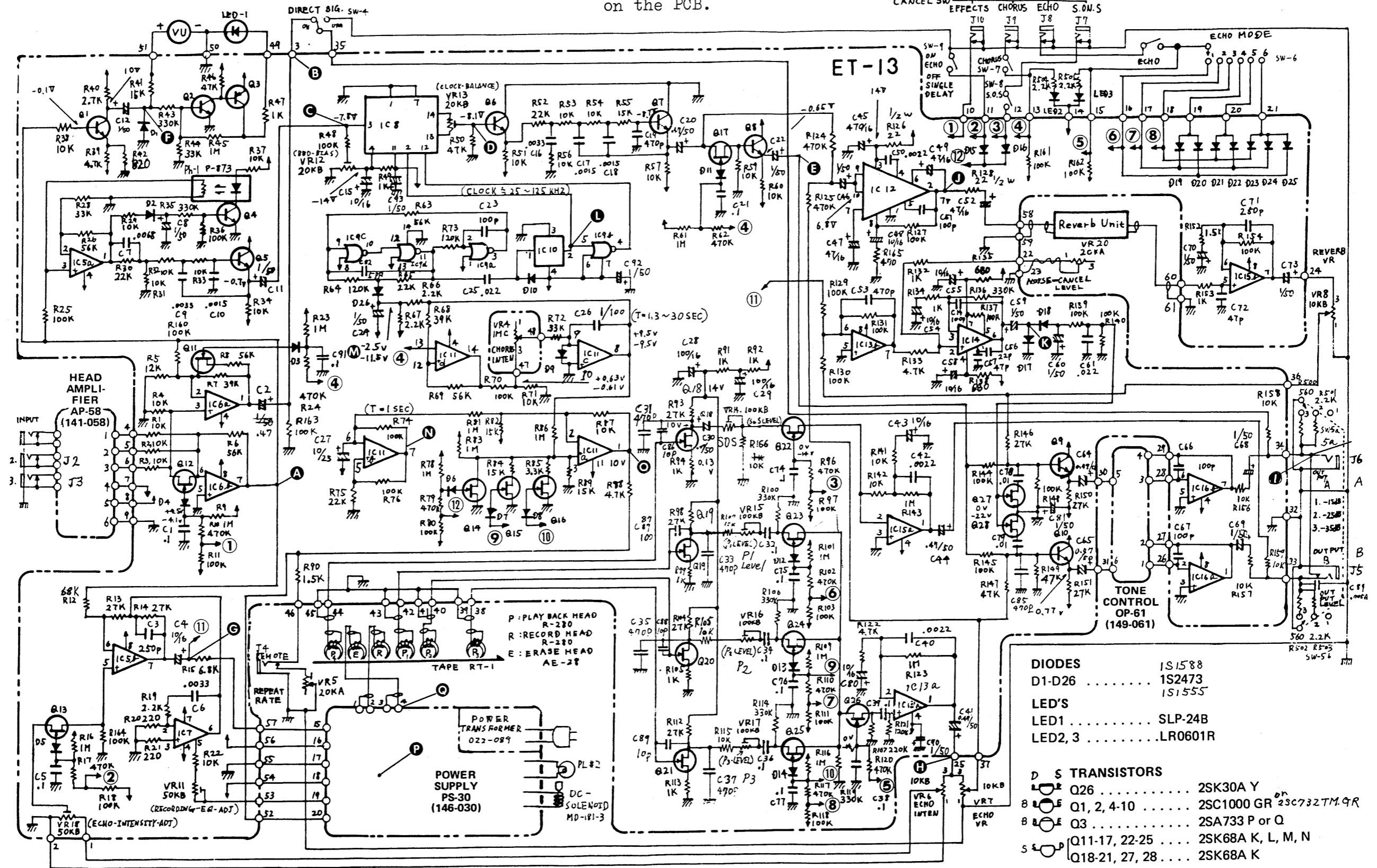

- DIODES**  
D1-D26 ..... 1S1588  
D1-D26 ..... 1S2473  
D1-D26 ..... 1S1555
- LED'S**  
LED1 ..... SLP-24B  
LED2, 3 ..... LR0601R
- D S TRANSISTORS**  
Q26 ..... 2SK30A Y  
Q1, 2, 4-10 ..... 2SC1000 GR 23c732TM.9R  
Q3 ..... 2SA733 P or Q  
Q11-17, 22-25 .... 2SK68A K, L, M, N  
Q18-21, 27, 28 .... 2SK68A K



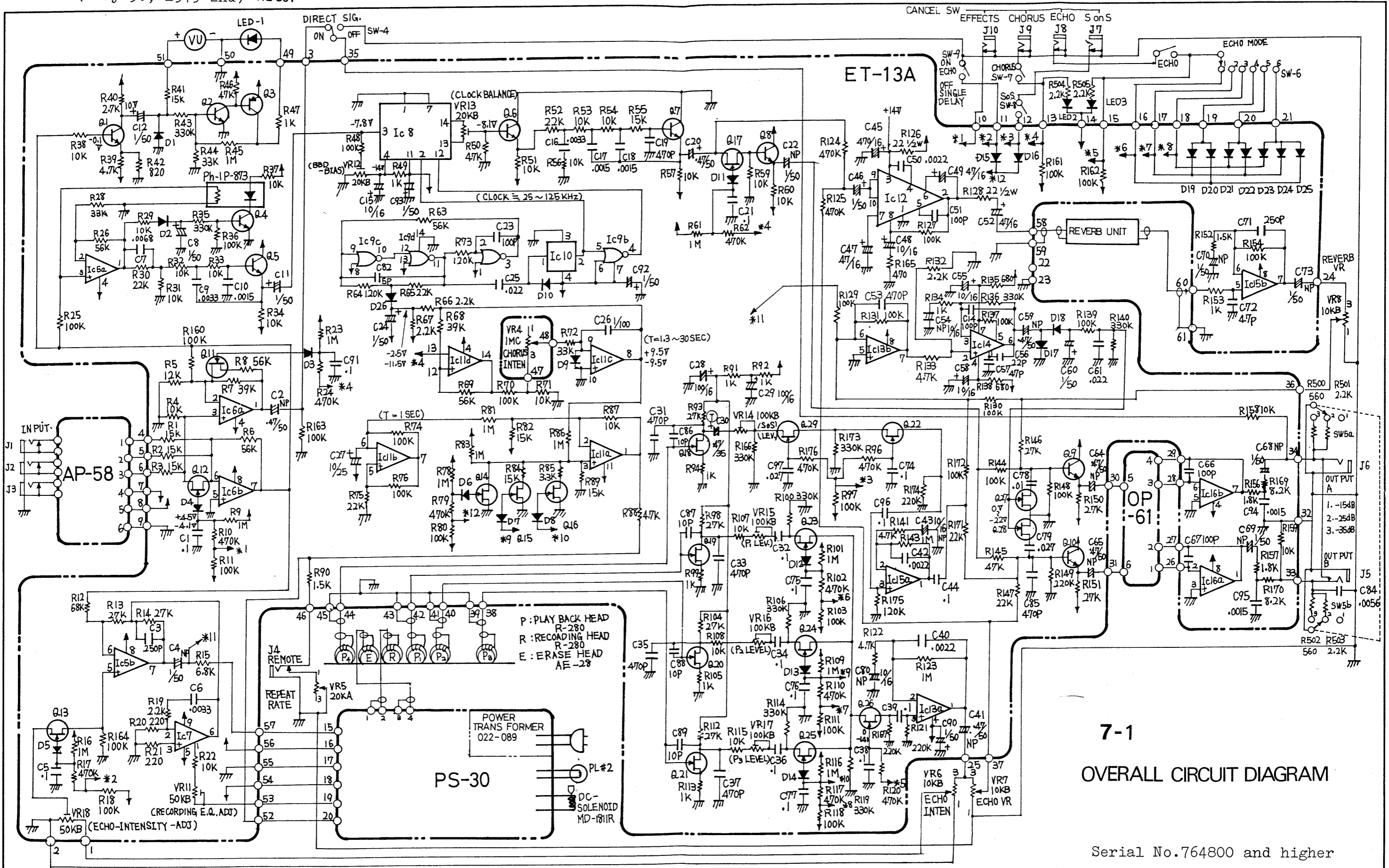

7-1  
OVERALL CIRCUIT DIAGRAM

Serial No.764800 and higher

- DIODES: D1 ~ D26 : 1S2473  
 TRANSISTORS : Q1, Q2, Q4 ~ Q10 : 2SC732TM-GR  
                   Q3 : 2SA733P or Q  
                   Q11 ~ Q17, Q22 ~ Q25 : 2SK68A-KLMN  
                   Q18 ~ Q21, Q27 ~ Q28 : 2SK68A-K  
                   Q22, Q29, Q26 : 2SK30A-Y  
 LEDs : LED1, 5LP-24B  
           LED2, LED3, GL-32AR

- I.C.S : Ic5, Ic6, Ic13, Ic15, Ic16 :  $\mu$ PC4558C  
           Ic7 : BA-662  
           Ic8 : MN3004  
           Ic9 : CD4001UBE  
           Ic10 : DN 819  
           Ic11 :  $\mu$ PC324C  
           Ic12 : TA7200P

Figures of the same number marked with "\*" are interconnected on the PCB.



# 8. TONE CONTROL OP-61 (149-061)

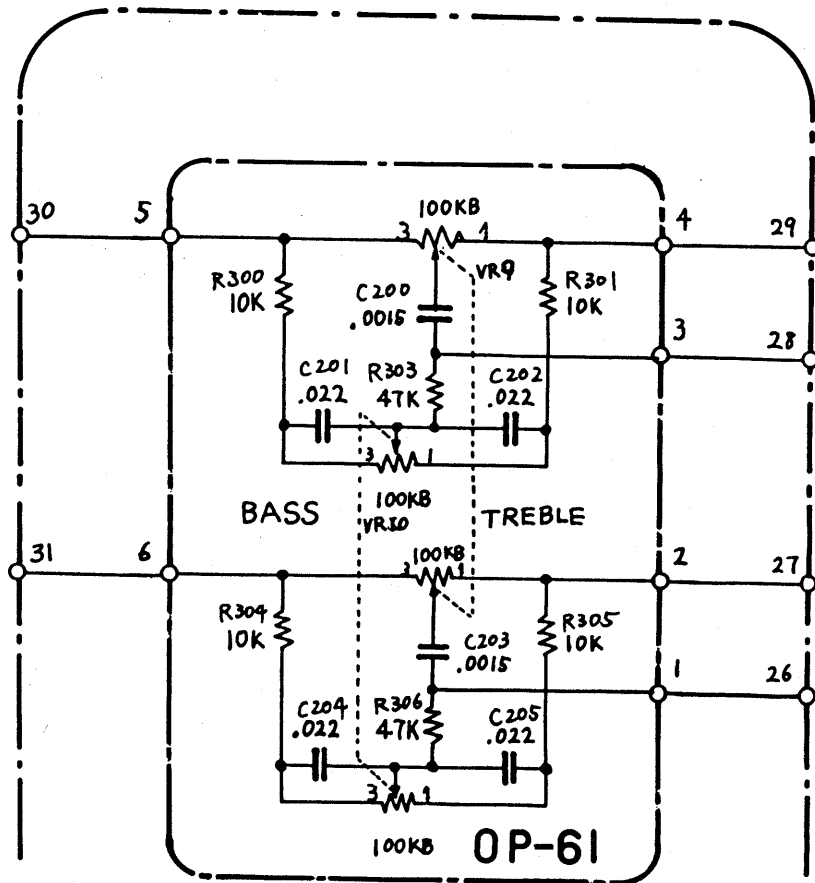
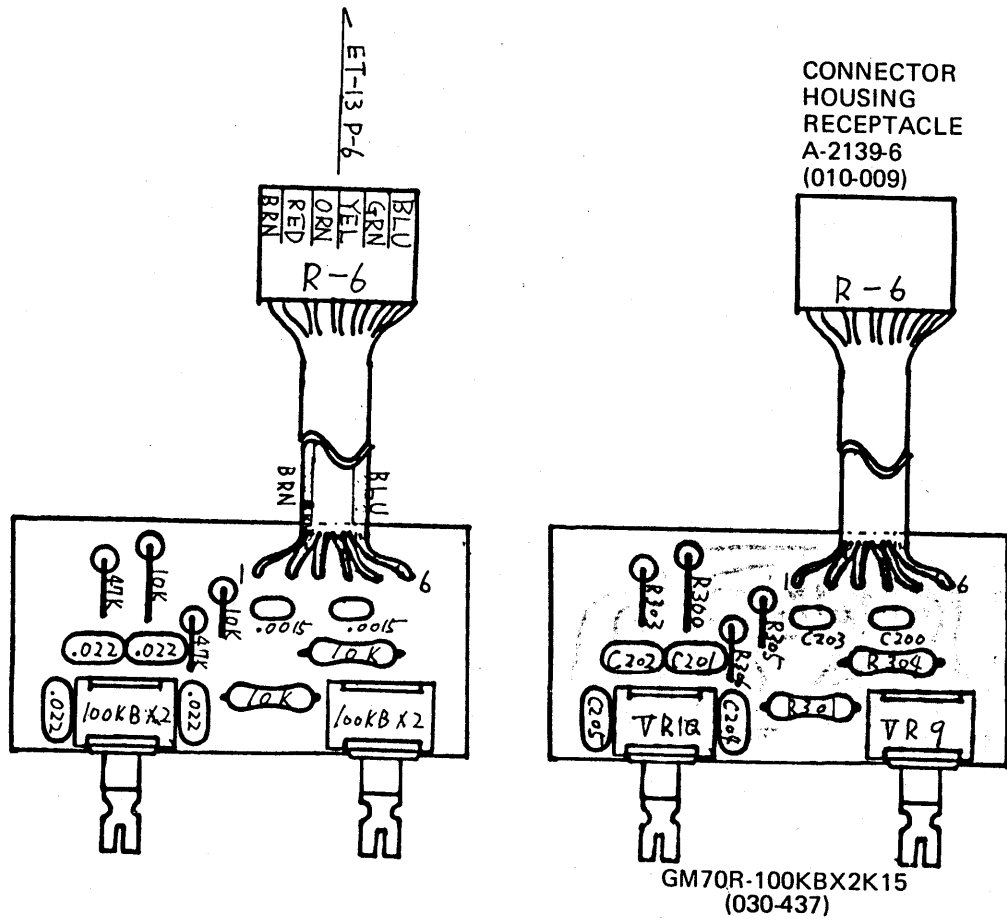

ET-13

# 9. HEAD AMPLIFIER AP-58 (141-058)

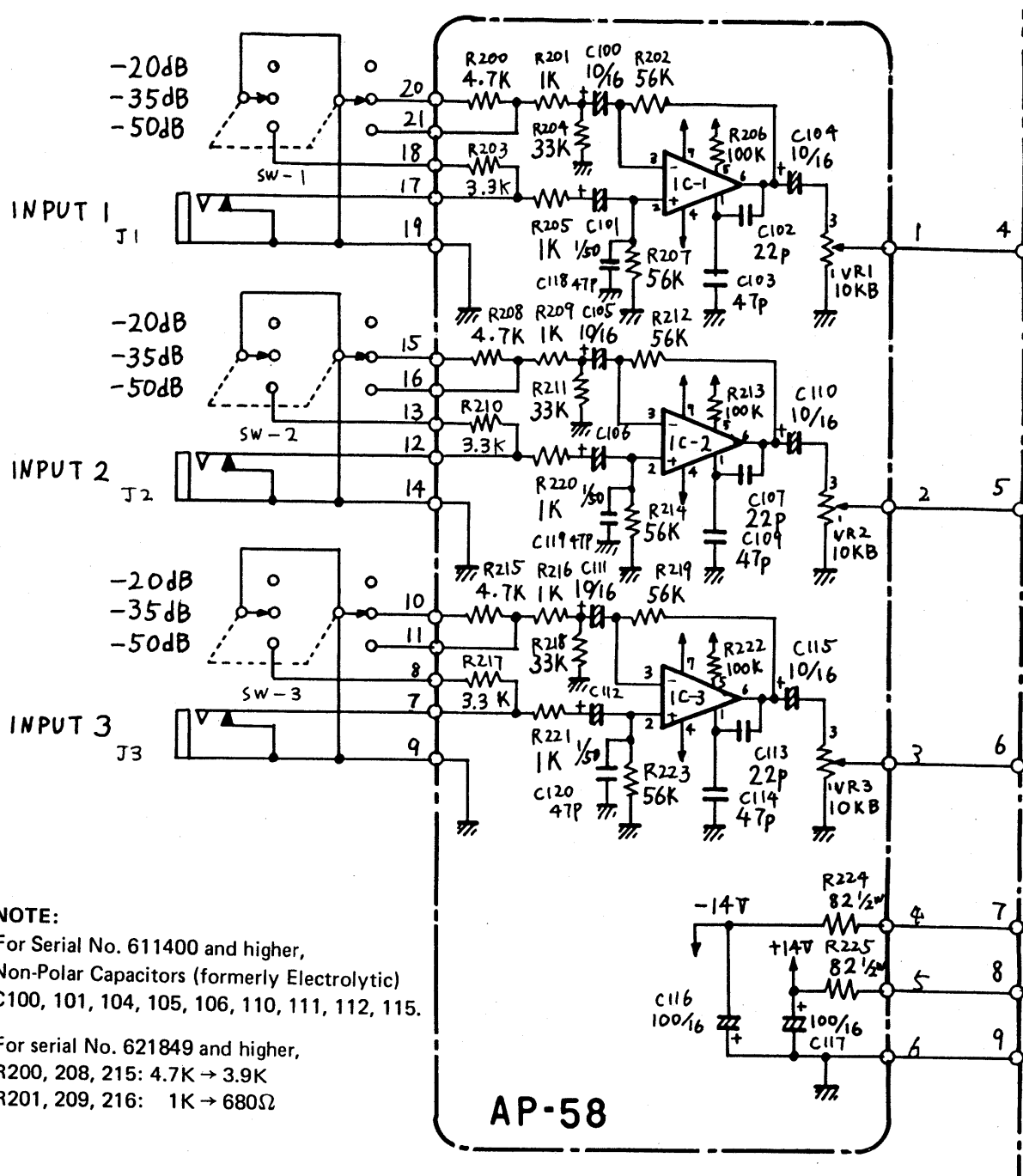
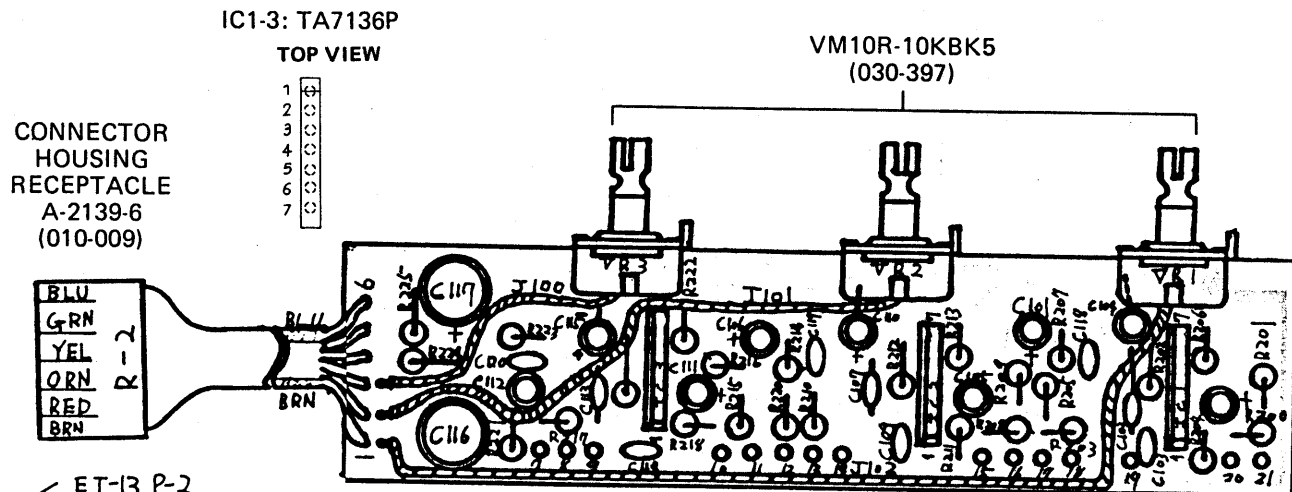

# 10. POWER SUPPLY PS-30 (146-030)

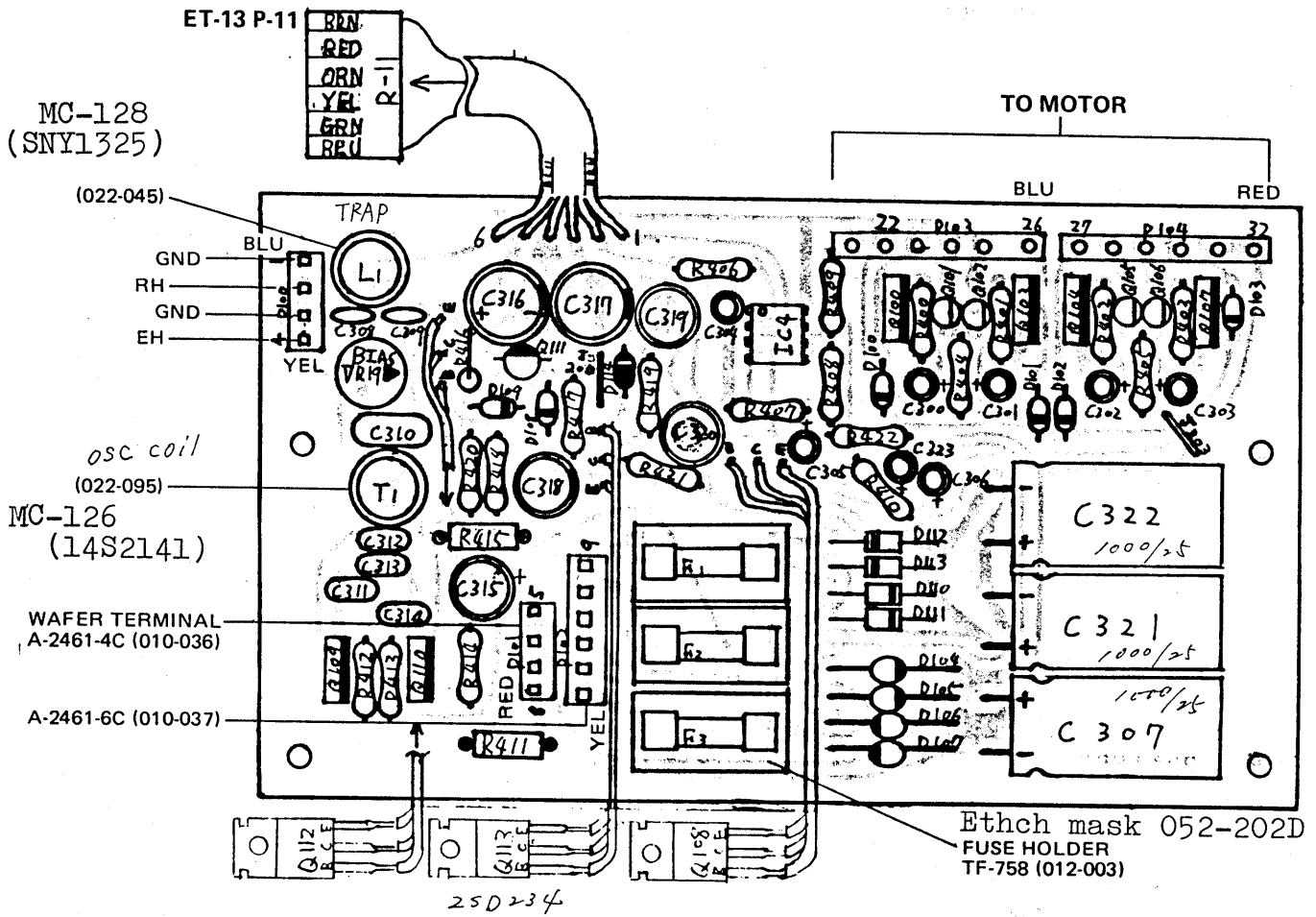

Serial No. 764800 and higher  
 Etch mask 052-202G (compatible, slight shift of pattern)

**AC LINE VOLTAGE - FUSE RATING**

	100-120V		220-240V (DNS)			220-240V	
F1	1.0A SGA	008-026	400mAT	Ⓢ	008-062	1.0A SGA	008-026
F2	1.0A SGA	008-026	400mAT	Ⓢ	008-062	1.0A SGA	008-026
F3	2.0A SGA	008-028	1.6AT	Ⓢ	008-069	2.0A SGA	008-028
F4	1.0A SGA	008-026	400mAT	Ⓢ	008-062	0.5A SGA	008-024

**IC**

IC4 ..... JRC4558D (NJM)  
 μPC4558C (NEC)

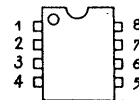

**DIODES**

- Ⓢ D100-103, 108, 109 .... 1S2473
- D104-107 ..... GM-3Z
- D110-113 ..... 1N4003
- D114 ..... 05Z-15

**TRANSISTORS**

- 110 Q100, 103, 104, 107, 109. 2SD571 L
- Q101, 102, 105, 106 .... 2SA733 P or Q
- Q108, 112 ..... 2SD234 O
- Q113 ..... 2SB434 O
- Q111 ..... 2SC1000 GR

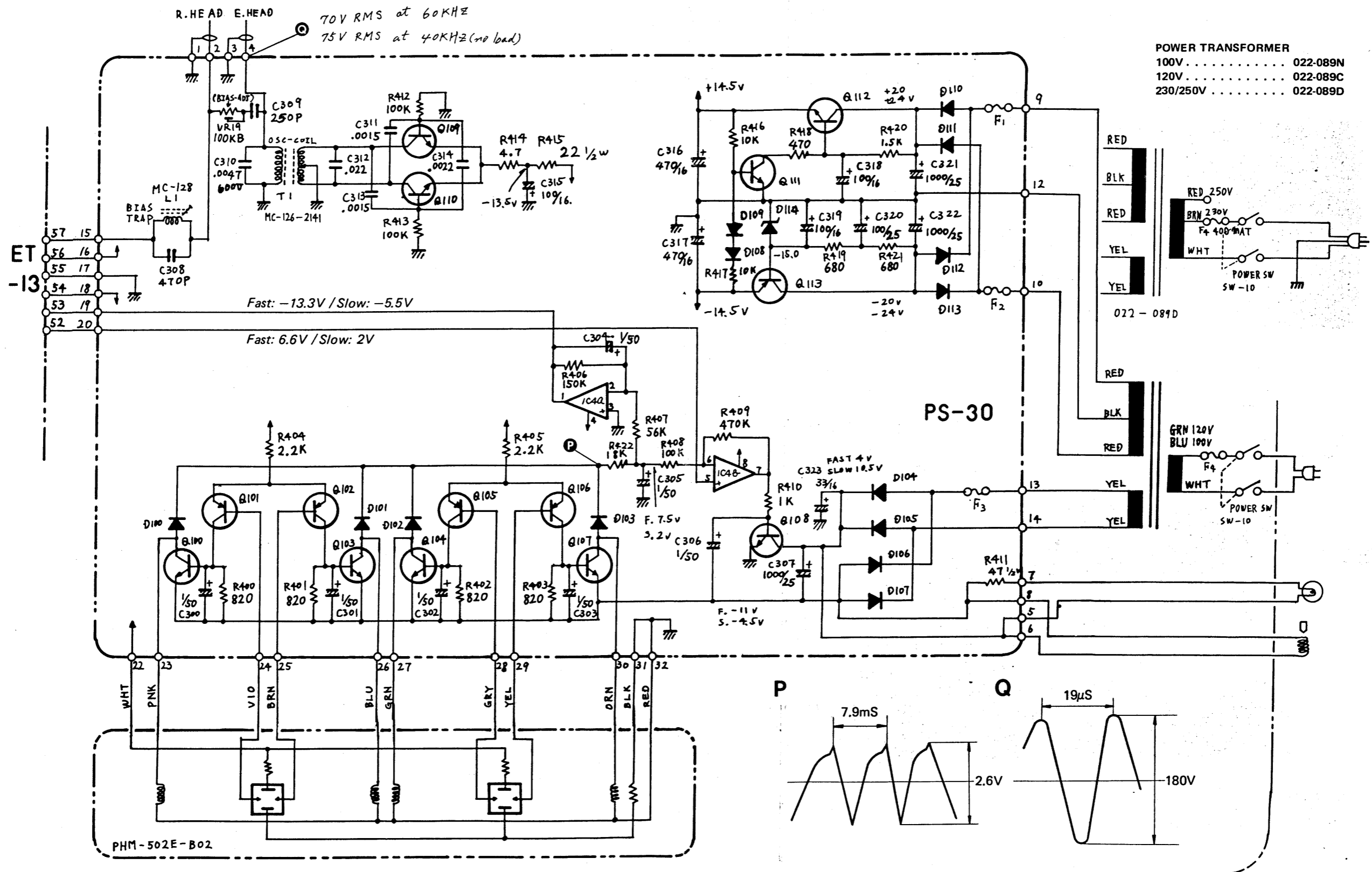

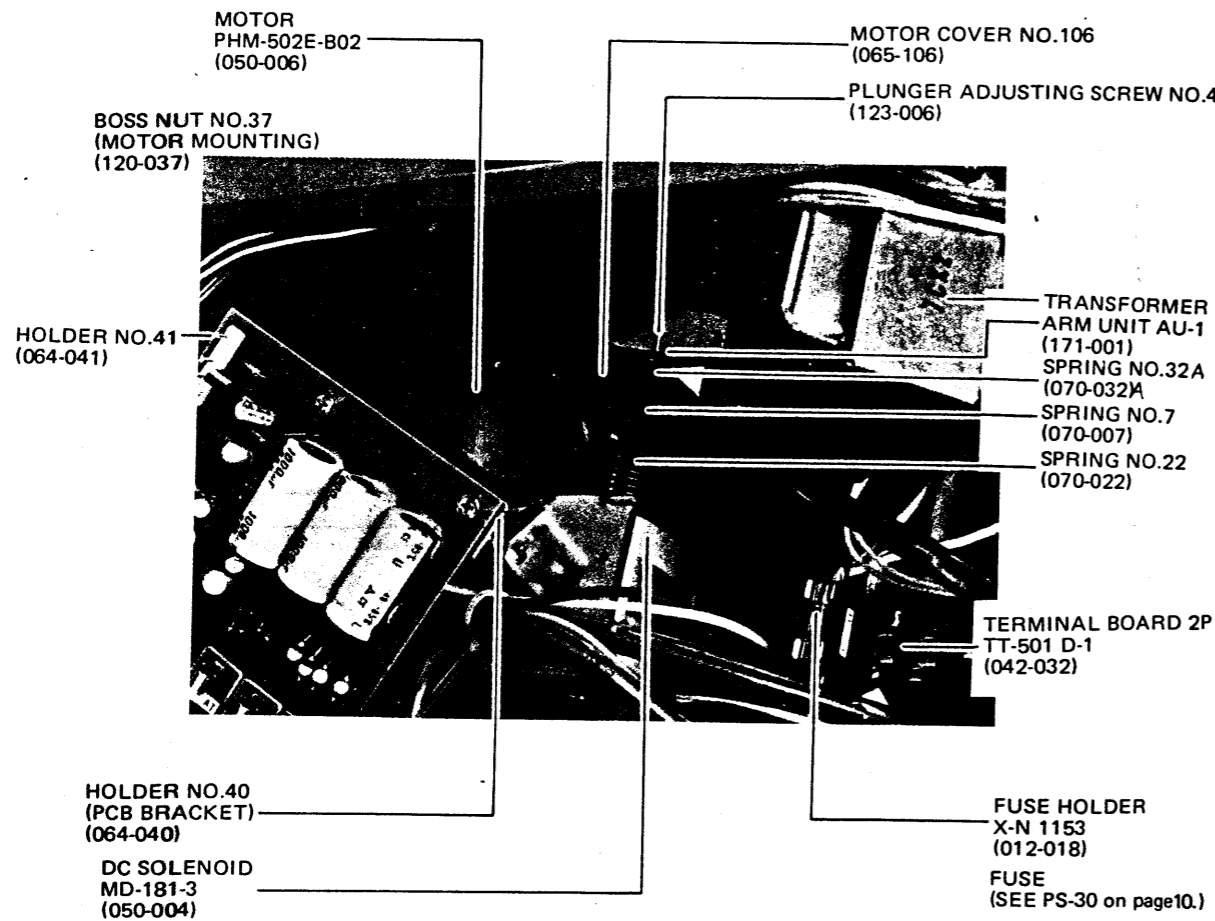
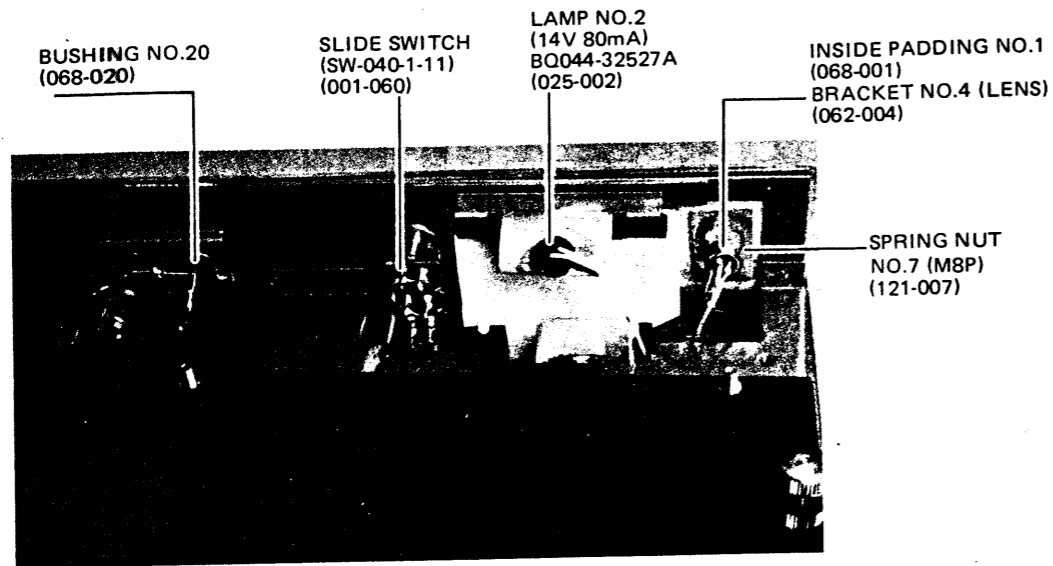

PARTS NO.	PARTS NAME AND DESCRIPTION	PARTS NO.	PARTS NAME AND DESCRIPTION
	CABINET ASS'Y (includes the following)		<b>SWITCHES</b>
081-078	Cabinet & Cover	001-254	Rotary SRN 1016S-k15
108-004	Carrying Handle H-15	001-012	Power WD-1311 (S6B-7 for 117V)
065-001	Cover, cord box	001-102	Midget 8A-1011
114-003	Clasp	001-018	Slide SW-321-1-1
115-002	Hinge obs.	001-060	Slide SW-040-1-11
111-017	Rubber Foot G-1	001-150	Push SUE-22A11
111-030	Rubber Foot G-9		
064-012	Angle H-12	009-001	Jack SG-7615 No.5
065-112	Ventilation Grille	046-003	VU Meter SK-50 → BK560 → EMT2410
		025-002	Lamp BQ044 (14V, 80mA) interchangeable
131-023A	Vinyl Cover #23A	040-001	Reverb Unit Z-3F
130-056	Carton No.156	010-028	Connector 3-pin A-2139-3
057-004	Cleaner Set	010-008	Connector 4-pin A-2139-4
057-006	Tape RT-1L (4.5m)	010-009	Connector 6-pin A-2139-6
053-013	Connection Cord LI-10	010-035	Wafer Terminal 3-pin A-2461-3C
061-138	Chassis, main	010-036	Wafer Terminal 4-pin A-2461-4C
061-160	Chassis, input	010-037	Wafer Terminal 6-pin A-2461-6C
061-161	Chassis, tone		
065-019	Cover No.19	022-095	OSC Coil MC-126-2141
073-024	Spacer No.24, (See photo, page 20.)	022-045	Trap Coil MC-128
063-013	Plate No.13	022-089N	Power Transformer (100V)
065-114	Head Cover	022-089C	Power Transformer (117V)
067-005	Guide Post, tape	022-089D	Power Transformer (220/240V)
064-025	Guide, tape		
064-127	Platform, head	012-003	Fuse Holder TF-758 (sec.)
070-005	Spring No.5	012-018	Fuse Holder X-N 1153 (prim.)
049-003	Record Head R-280MR	042-032	Terminal TT-501D-1 2P
049-004	Playback Head R-280MP	047-025	Line Cord Strain Relief EA-5
049-001	Erase Head AE-28		
065-118	Shield, head		<b>TRANSISTORS</b>
113-001	Pinch Roller No.1	017-010	2SD-234 (O)
068-006	Cover, pinch roller	017-022	2SB-434 (O)
101-001	Felt No.1, pinch roller	017-072	2SD-571 (L)
050-006	Motor PHM-502E-B02	017-003	2SC-1000 (GR) or 2SC732TM-GR
065-106	Motor Cover	017-012	2SA-733 (P) or (Q)
120-037	Motor Mounting Nut		<b>FET's</b>
069-009	Shaft (for motor mounting)	017-081	2SK-68A (K) (L/M/N)
		017-014	2SK30A (Y)
171-001	ARM UNIT ASS'Y AU-1 (includes the following)		<b>DIODES</b>
050-004	DC SOLENOID	018-014	1S-2473 (1S-1555)
070-007	Spring	018-064	GM-3Z
070-022	Plunger Spring No.22	018-022	1N-4003
070-032	Spring No.32	018-024	Zener 05Z-15 (500mW, 15V)
123-006	Plunger Adjusting Screw	019-003	LED SLP-24B
		019-008	LED GL-32AR
064-040	Bracket No.40 (PS-30)	019-011	Photocoupler P873A (RE) or (WHT)
064-041	Bracket No.41 (PS-30)		<b>IC's</b>
016-004	Button No.4 YG (push switch)	020-028	TA-7200P
016-026	Knob TK-1113	020-071	JRC (NJM) 4558D
016-021	Knob TK-1114 (small)	020-015	CA3080A or 020-160 BA662
062-004	Bracket No.4, lens (SLP-24B)	020-027	TA7136P
068-001	Pad (inside bracket No.4)	020-067	CD4001UBE or 020-194 TC4001UBP
121-007	Spring Nut No.7 M8P (Bracket No.4)	020-069	μPC324C
068-020	Bushing No.20 (GL-32AR)	020-063	MN3004
064-033	PCB Holder No.33 LCBS-4N	020-039	DN819
			<b>PCB</b>
		151-013	ET-13 Assembly
		052-203C	ET-13 less parts
		141-058	AP-58 Assembly
		052-200B	AP-58 less parts
		149-061	OP-61 Assembly
		052-201B	OP-61 less parts
		146-030	PS-30 Assembly
		052-202D	PS-30 less parts -- 202G

# ADJUSTMENT AND CHECKING

## 1. MECHANICAL ADJUSTMENT

### 1-1. TAPE CHASSIS POSITION

Adjust the tape chassis position so that the clearance from the motor shaft is 1mm. See Fig.1. Secure it by tightening 2 screws at the rear section of the chassis.

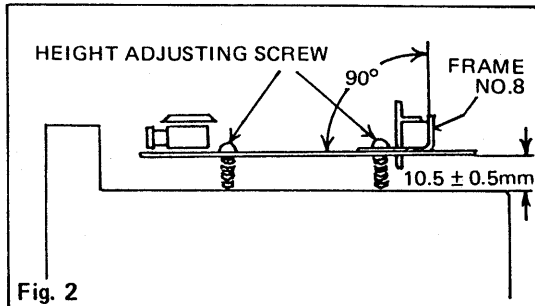
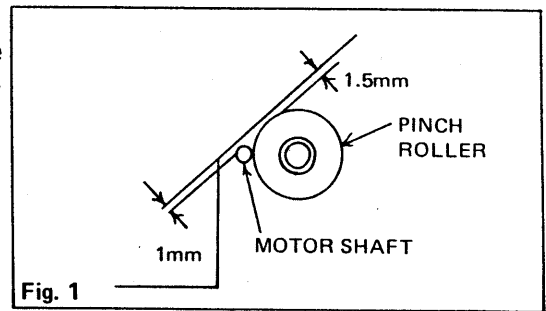

### 1-2. TAPE CHASSIS HEIGHT (TEMPORARY)

Adjust the tape chassis height so that it is  $10.5 \pm 0.5\text{mm}$  above the main chassis. See Fig.2. (Make sure that Frame No.8 is not deformed.)

### 1-3. LEAF SPRING PRESSURE

Adjust position of Frame No.10 so that the tension to separate the leaf spring from the bearing roller is 25 – 30g. See Fig.3.

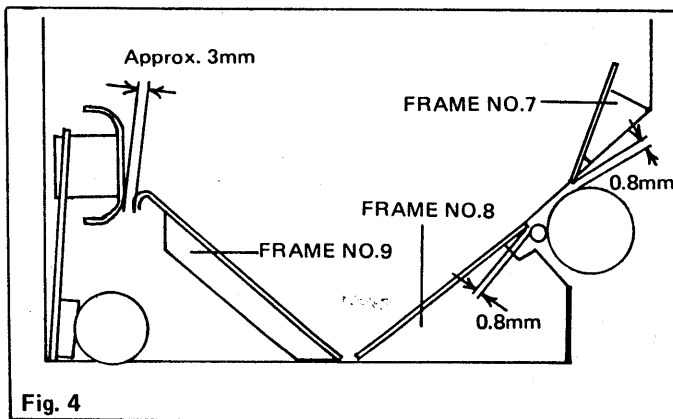
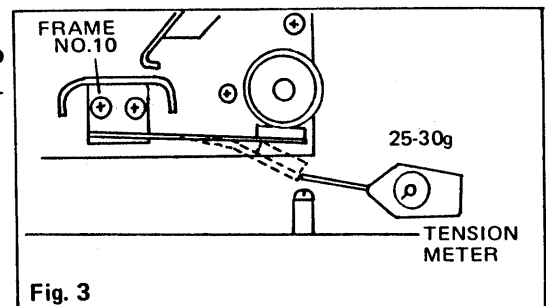

### 1-4. POSITION OF FRAMES NOS. 7, 8 AND 9

Secure the frames as illustrated in Fig.4.

#### CAUTION:

Make adjustment of position of Frames Nos. 7 and 8 accurately with the pinch roller in contact with the motor shaft.

### 1-5. PINCH ROLLER PRESSURE

Plug in the power cord and turn switch on. Adjust the solenoid position so that the tension to separate the pinch roller from the motor shaft is 1.0 – 1.4kg, using a spring balance. See Fig.5.

CAUTION: Make sure that pinch roller surface is perfectly parallel with the motor shaft.

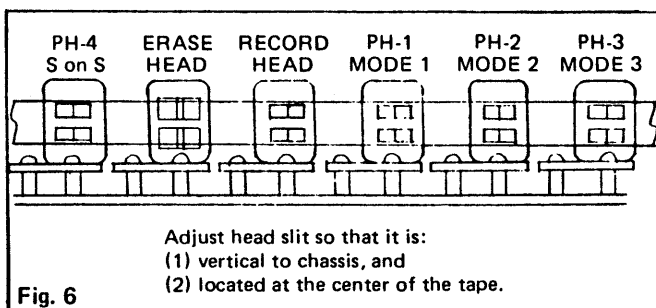
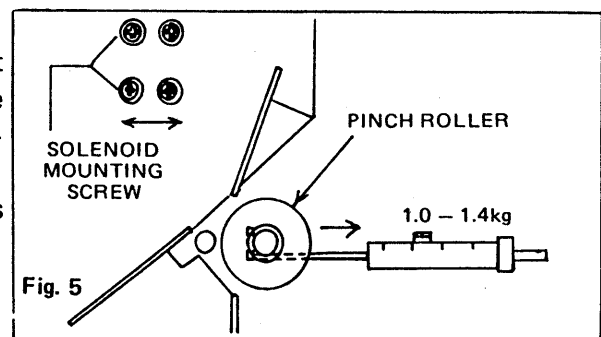

### 1-6. TAPE PACK HEIGHT (FINAL)

- Thread the tape and run it.
- Consulting Fig.6, visually adjust the head alignment. (This alignment must be made first, otherwise tape cannot run stably.) Then proceed to electrical adjustment.

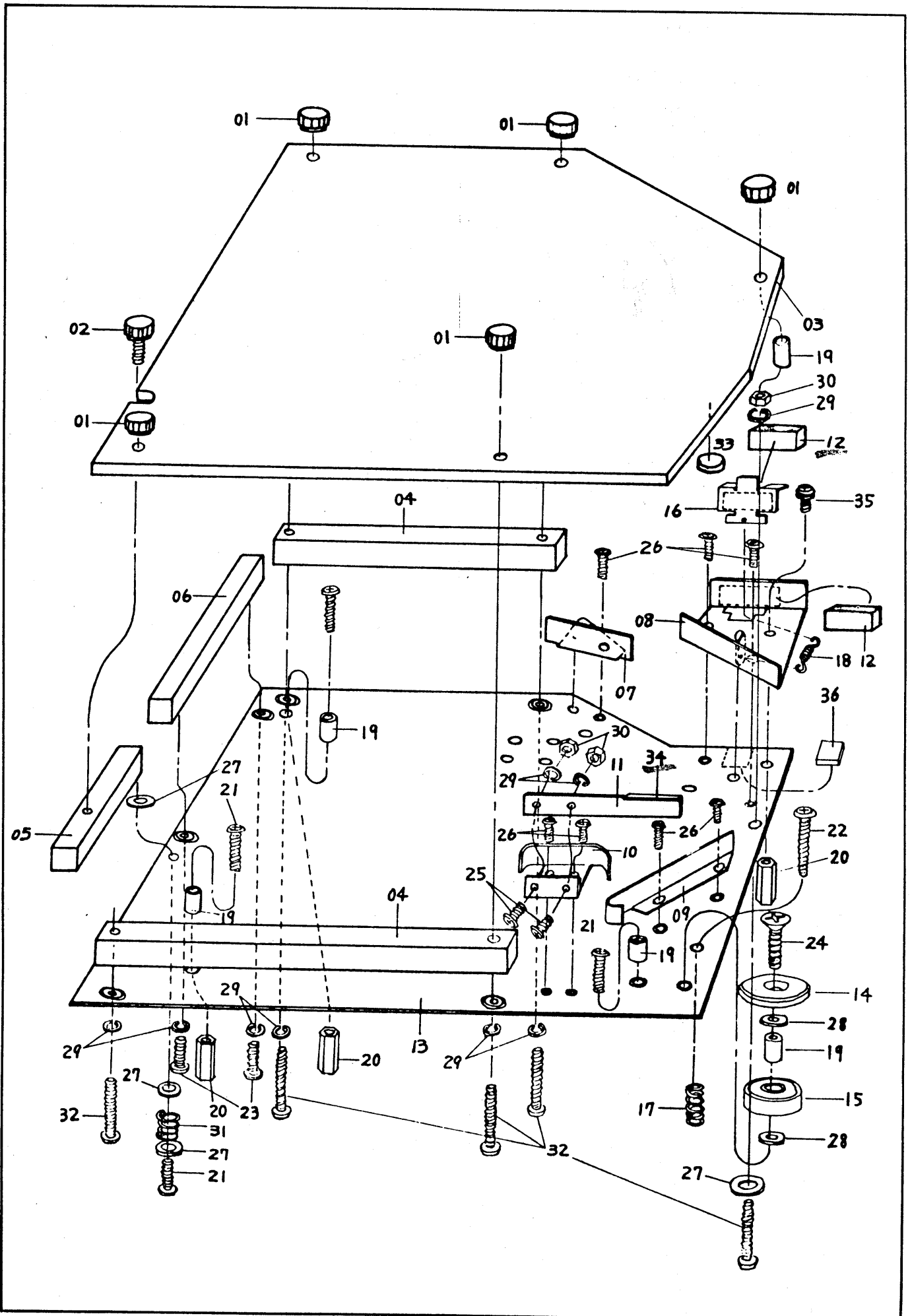



NO.	PARTS NO.	PARTS NAME AND DESCRIPTION
01	120-036	Nut, Decoration, M3
02	123-004	Screw, Decoration, M3
03	092-004	Top cover No.4, pack (acrylic)
04	079-004	Frame No.4
05	079-005	Frame No.5
06	079-006	Frame No.6
07	079-007	Frame No.7
08	079-008	Frame No.8
09	079-009	Frame No.9
10	079-010	Frame No.10
11	070-033	Leaf spring No.33
12	101-017	Felt No.17.....2226010301
13	061-063A	Chassis No.63A
14	065-113	Cover, Bearing
15	113-004	Bearing
16	063-011	Plate No.11
17	070-017	Spring No.17, Support for chassis
18	070-018	Spring No.18
19	*	Collar (plastic), M3 x 6mm
20	120-001	Sleeve Nut No.1, 10mm
21	*	Screw, B.H. M3 x 12mm, Nickel
22	*	Screw, B.H. M3 x 15mm, Chrome
23	*	Screw, B.H. M3 x 6mm,
24	*	Screw, O.H. M3 x 15mm, Nickel
25	*	Screw, B.H. M3 x 6mm,
26	*	Screw, T.H. M2.6 x 4mm, Nickel
27	*	Plain washer M3 x 8 x 0.5mm
28	121-035	Plain washer No.35, M3 x 8 x 0.3mm Phosphor bronze
29	*	Spring washer M3
30	*	Nut, Hex M3
31	070-005	Spring No.5
32	*	Screw, B.H. M3 x 18mm
33	101-008	Felt Chip No.8
34	101-026	Felt No.26.....2226010501
35	*	Screw, SEMS M3 x 8mm, Chrome (wire spring washer)
36	107-004	Cushion No.4

\* R-280MR  
can be used for  
R-280MP

型番 #6  
環形  
RE-150 鉄通

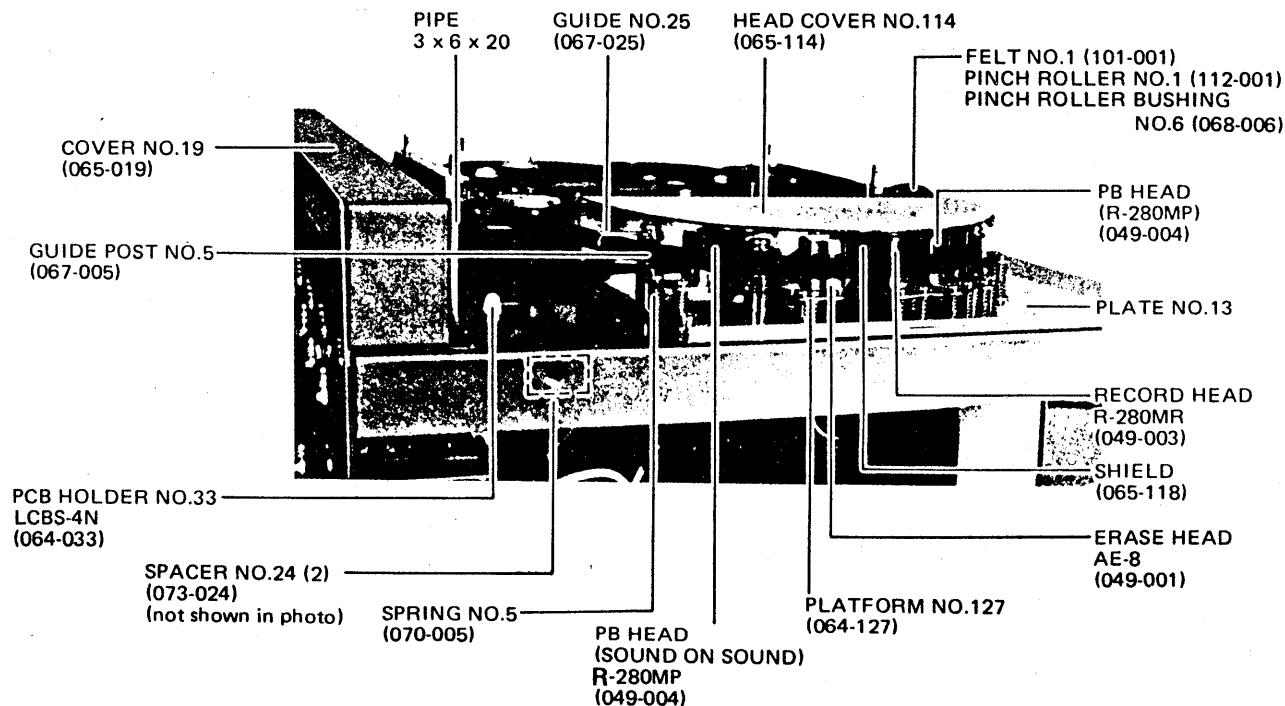

2. ELECTRICAL ADJUSTMENT

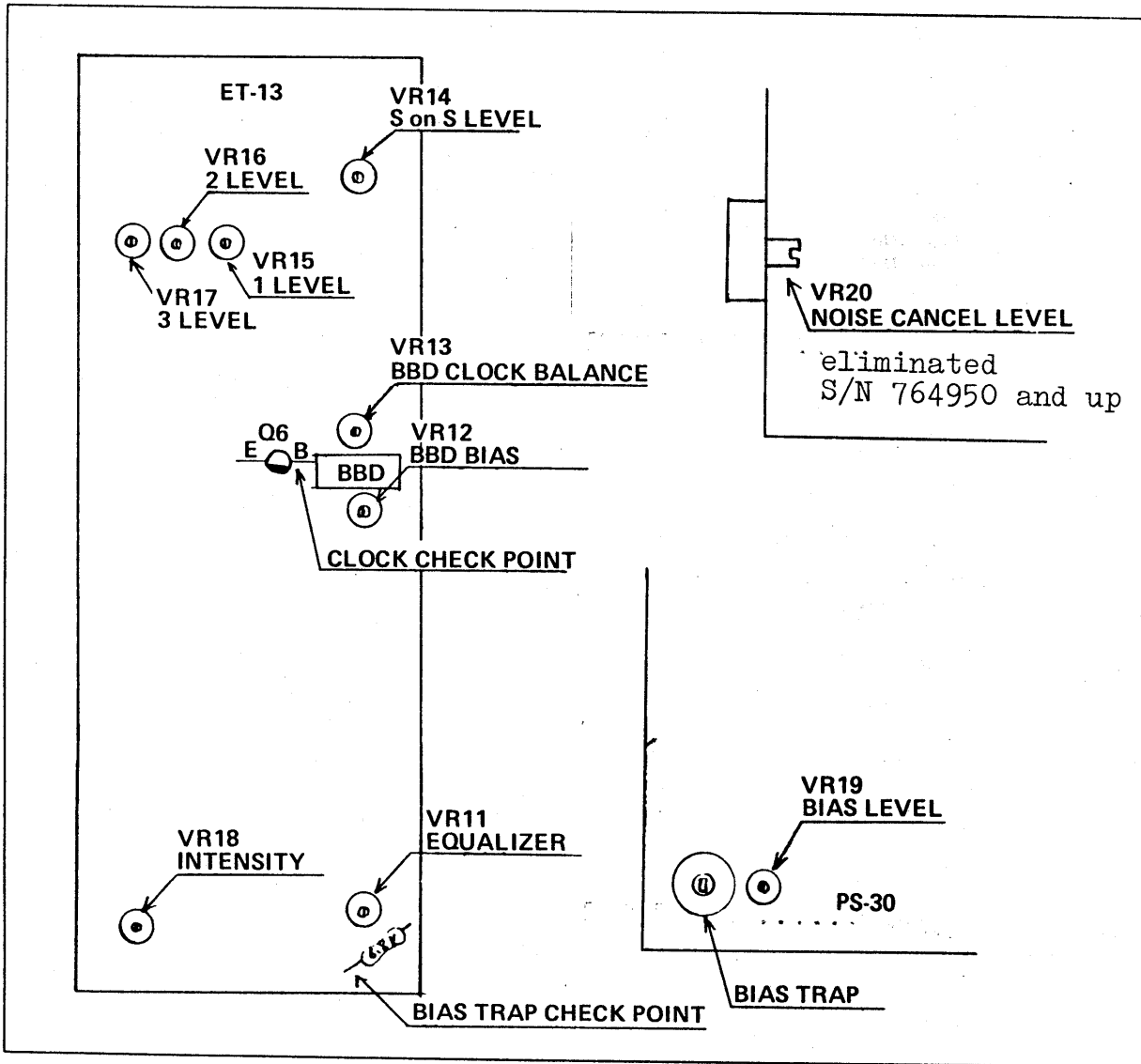

SETTING OF SWITCHES AND CONTROLS ON FRONT PANEL FOR ADJUSTMENT

	ECHO	CHORUS	SOUND ON SOUND	REVERB	DIRECT
Input Level Switch	-50dB	-50dB	-50dB	-50dB	-50dB
Input Volume	Max.	Max.	Max.	Max.	Max.
Output Level Switch	-15dB	-15dB	-15dB	-15dB	-15dB
Echo Switch	ON	OFF	OFF	OFF	OFF
Echo Mode Switch	as specified	-	-	-	-
Echo Volume	Max.	-	-	-	-
Repeat Rate	as specified	-	as specified	-	-
Chorus Switch	OFF	ON	OFF	OFF	OFF
Chorus Intensity	-	as specified	-	-	-
Direct Signal Switch	OFF	OFF	OFF	OFF	ON
Reverb Volume	Min.	Min.	Min.	Max.	Min.
Sound on Sound Switch	OFF	OFF	ON	OFF	OFF
Echo/Single Delay Switch	Single Delay	-	-	-	-
Tone Controls	Center	Center	-	-	-

\*Switches or controls marked - may be set to any position.

\*\*When Direct Signal Switch is set to OFF with other controls at DIRECT setting, the output should be 0.

\*\*\*For adjustment, output should be taken through Output Jack A.

INSTRUMENTS: Audio Generator  
AC VTVM, 2 units  
Oscilloscope

## 2-1. TRAP COIL ADJUSTMENT

Note: This adjustment is necessary only when repairing the unit which may cause the change in oscillation frequency.

The core is subject to breakage unless driver that fits closely is used.

Setting: Input – 0

Single Delay Switch – Single Delay

Measuring point:

BIAS-TRAP CHECK POINT on ET-13 Main Board

Measuring method:

Adjust trap coil on PS-30 to obtain minimum leakage of bias voltage. It should be not over than 20mVrms on AC VTVM.

## 2-2. HEAD AZIMUTH

Setting: Input – 1KHz square wave, 3.8mV

Set to obtain Echo

Repeat Rate – Center

Measuring point:

Output Jack, with Oscilloscope and AC VTVM

Measuring method:

- a) Adjust each head so that it is vertical to the chassis and the head gap is positioned at the center of the tape.
- b) Fine adjust so that level from each head is maximum and treble is produced best.
- c) The alignment should be made in the order of Recording Head, Playback Head 1, 2, and 3, and Sound on Sound Head.

## 2-3. BIAS CURRENT ADJUSTMENT

Setting: The same as above, 9-2-2.

Echo mode – 1

Measuring point:

The same as above, 9-2-2.

Measuring method:

Adjust bias potentiometer VR19 on PS-30 to obtain maximum output.

## 2-4. DIRECT OUTPUT LEVEL

Setting: Input – 1KHz sine wave, 3.2mV

Set to obtain only Direct sound.

Measuring point:

Output Jack, with Oscilloscope and AC VTVM

Measuring method:

Make sure the output level is 89mV, for each of Input Jacks 1, 2 and 3.

**2-5. ECHO OUTPUT LEVEL**

Setting: Input – 1KHz sine wave, 3.2mV

Set to obtain Echo sound.

Repeat rate – Center

Measuring point:

Output Jack, with Oscilloscope and AC VTVM.

Measuring method:

Adjust VR15 to obtain the same output level as Direct output level with Echo Mode Switch at 1; VR16 with the switch at 2; and VR17 with the switch at 3.

**2-6. SOUND ON SOUND OUTPUT LEVEL**

Setting: Input – 1KHz sine wave, 3.2mV

Set to obtain Sound on Sound sound

Repeat Rate – Center

Measuring point:

Output Jack, with Oscilloscope and AC VTVM

Measuring method:

Adjust VR14 to obtain the same output level as Direct output level.

**2-7. EQUALIZER**

Setting: Input – 1KHz, square wave, 3.8mV

Set to obtain Echo sound.

Mode Selector – 1

Tone control – BASS, Center

TREBLE, 1 graduation up from Center

Measuring point:

Output Jack, with Oscilloscope

Measuring method:

Adjust equalizer potentiometer VR11 so that the higher frequency response with Repeat Rate at Center equals that with Repeat Rate at Minimum. Turning VR11 counterclockwise lifts higher frequency response.

**2-8. INTENSITY**

Setting: Input – 0

Set to obtain Echo sound.

Single Delay Switch – Echo

Mode Selector – 1

Measuring point:

Output Jack, with Oscilloscope and AC VTVM, and also connect to an amplifier/speaker.

Measuring method:

Adjust Intensity Potentiometer VR18 so that oscillation occurs with Intensity Control on Panel at Point A and the level is the same as Direct output level.

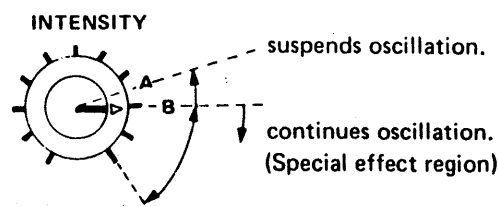

**2-9. BBD BIAS OF CHORUS CIRCUIT**

Setting: Input – 1KHz square wave, over 3.8mV

Set to obtain Chorus sound

Chorus Intensity – Maximum

Measuring point:

Output Jack, with Oscilloscope and AC VTVM

Measuring method:

Adjust BBD Bias Potentiometer VR12 so that output waveform is clipped neither at top nor bottom, that the level is 65mV and also that the waveform swings horizontally.

**2-10. BBD CLOCK BALANCE**

Setting: Input – 0

Set to obtain Chorus sound.

Chorus Intensity – Maximum

Measuring point:

Base of Transistor Q6, Oscilloscope

Measuring method:

Adjust Balance Potentiometer VR13 to obtain waveform of Fig.B, in the illustration below.

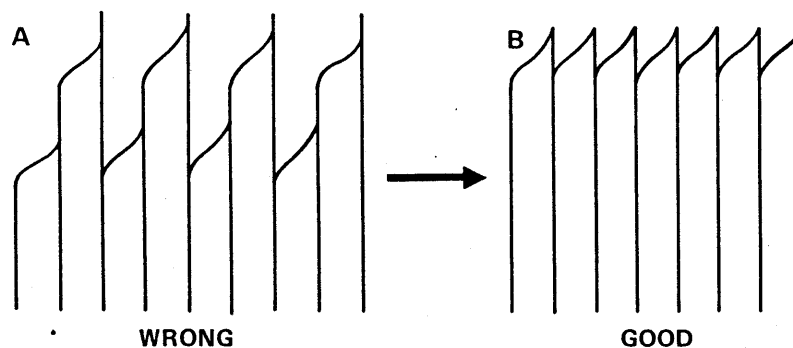
**2-11. REVERB OUTPUT LEVEL**

Setting: Input – 1KHz sine wave, 3.2mV

Set to obtain Reverb sound alone.

Reverb Volume (VR8) – Maximum

Measuring point:

Output Jack, with Oscilloscope and AC VTVM

Measuring method:

Make sure that output waveform is not clipped and the level is approximately 80mV.

**2-12. NOISE CANCEL CIRCUIT** (needless serial no. 764950 and higher)

Setting: Input – 0

Set to obtain Echo sound.

Measuring point:

Output Jack, connect to an amplifier/speaker with gain set at maximum.

Measuring method:

Adjust Noise Cancel Potentiometer VR20 so that noise at spliced part of tape is not heard.