

MRS-2 SERVICE NOTES

•SPECIFICATIONS

•KEYBOARD

(37 keys, 3 octaves, F-F)

•VCO (VOLTAGE CONTROLLED OSCILLATOR) (X2)

VCO RANGE (16', 8', 4')

WAVEFORM (△, □, ▽)

PULSE WIDTH (50%, 40%, 20%, 10%)

•VCF (VOLTAGE CONTROLLED FILTER)

HPF CUTOFF (40Hz - 5kHz)

LPF CUTOFF (20Hz - 20kHz)

•ENVELOPE GENERATOR (1 EACH FOR VCF, VCA)

ATTACK TIME (0.6ms - 3sec)

DECAY TIME (14ms - 10sec)

SUSTAIN LEVEL (0 - 100%)

RELEASE TIME (14ms - 10sec)

•LFO (Low Frequency Oscillator)

WAVEFORM (△, □, ▽)

LFO RATE (0.1Hz - more than 80Hz)

•DELAY/BEND SECTION

DELAY TIME (0 - 10sec)

•TUNING

MASTER TUNING (greater than ±1 semitone)

VCO-2 "A" TUNING (greater than ±1 octave)

VCO-2 "B" TUNING (greater than ±1 octave)

•CONTROLLER SECTION

PORTAMENTO (0 - 3sec)

VCO : greater than +1 octave

VCF : greater than +2 octaves (resonance pitch)

VCA : greater than +6dB, -12dB

•INPUTS AND OUTPUTS

OUTPUT LEVEL selector (H: 0dBm, M: -6dBm, L: -12dBm)

HEADPHONE jack (stereo, 8Ω)

HEADPHONE LEVEL selector (H, M, L)

BEND CONTROL IN jack;

with BEND SENSITIVITY control at "10"

VCO: approx 2v/8va

VCO : approx 2v/8va

VCF : approx 1v/8va

VCA : approx 1v/2.2dB

CV OUT jack (1v/ 8 va)

GATE OUT jack (+10v)

CV IN jack (1v/8va)

GATE IN jack (greater than +10v)

•GENERAL

Power consumption: 20w

Overall size: 765(w)x402(d)x162(h)mm

Weight: 14kg

Accessories: 2.5m connection cord

SDG5P-501-1 (001-215)
100V

SDG5P-501-2 (001-216)
117V

SDG5P-502 (001-217)
220/240V

Button No.9 (016-009)

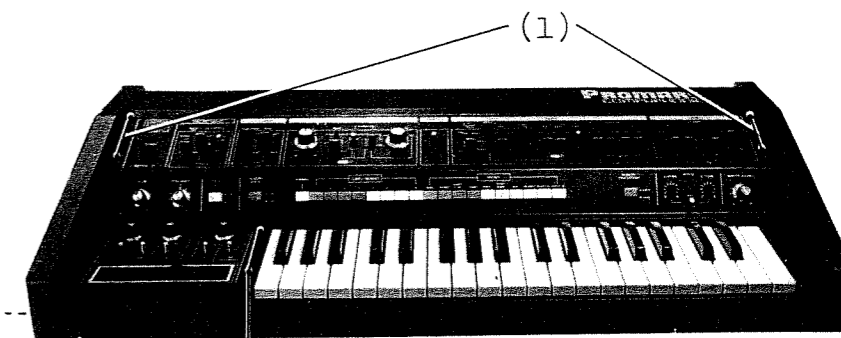

Removal Screws

(1) --- Front Upper panel

(2) --- Bender Control Block

(3) --- Keyboard

(2)

Blind H52
(065H052)

End block No.17A
(091-017A)

(2)

(3)

(3)

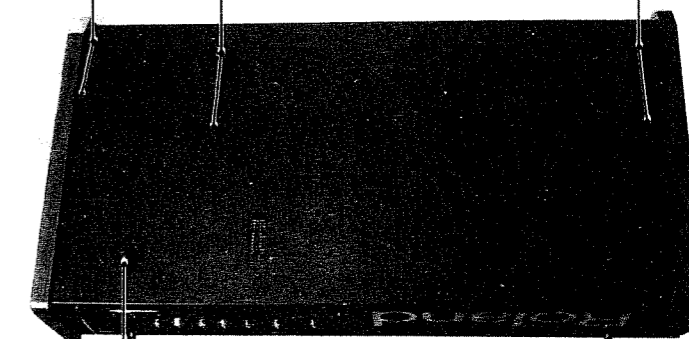

Foot (collar) BU480 CA25
black (111-024)

Felt No.27
(101-027)

Knobs No.56
(016-056)

Panel No.268B
(072-268B)

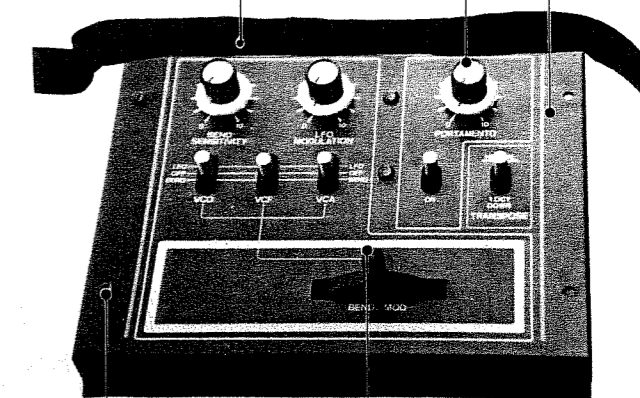

Nylon Rivet
NRP-335 4pcs
(122-001)

Bender
Unit PB-4
(029-022)

Knob No.56
(016-056)

Panel No.265D (072-265D)

Knob No.33
(016-033)

Side Panel No.70B
(083-070B)

Knob No.57
(016-057)

Side Panel No.69B
(083-069B)

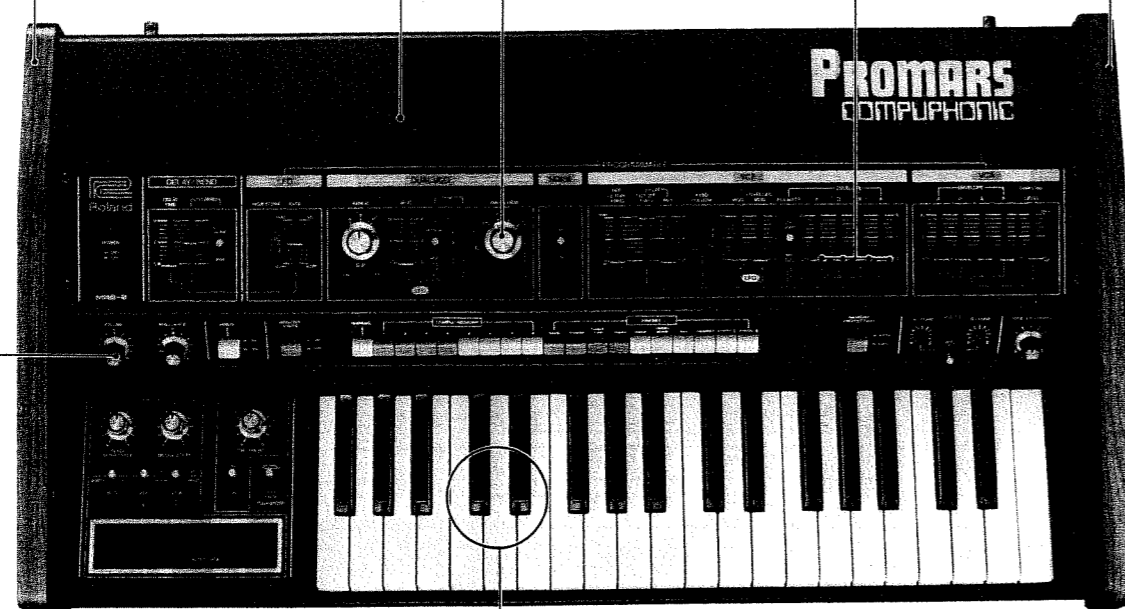

Keyboard assy SK-132G (004-011)

Buttons

No.9 Black (016-009)
No.85 White (016-085)
No.89 Blue (016-089)

No.86 Red (016-086)
No.87 Green (016-087)
No.88 Yellow (016-088)

Holder No.203B (064-203B)

Holder No.205B (064-205B)

Holder No.204B
(064-204B)

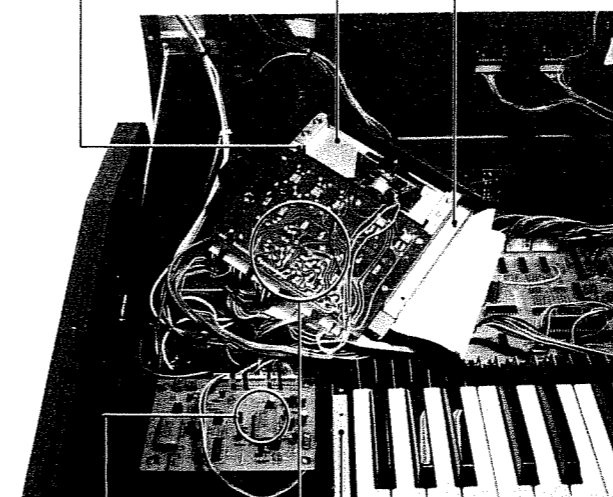

Holder No.232A
(064-232A)

Bender Board
OP-107 (149-107)

Key CV Board CV-3
(152-003)

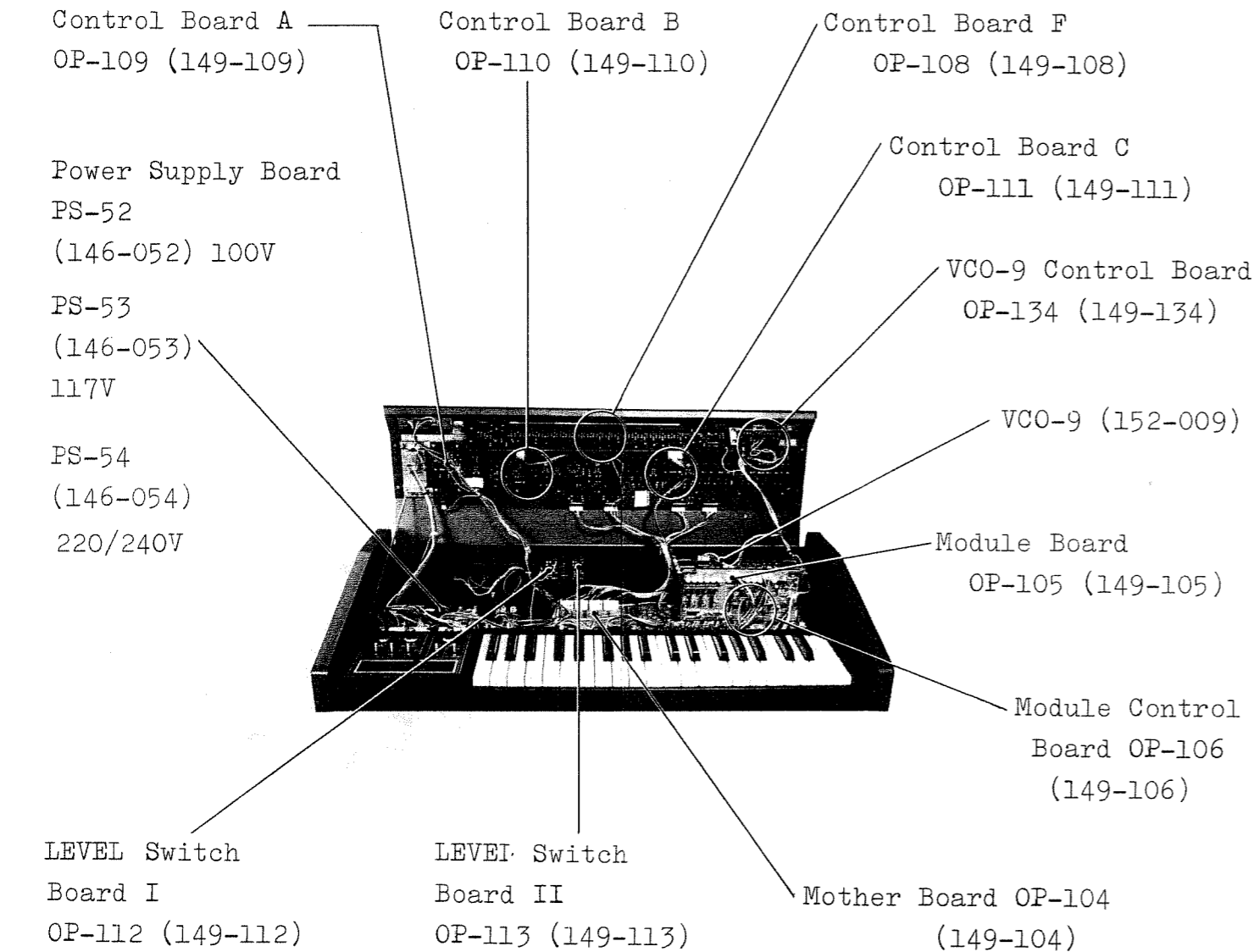

KEYBOARD PARTS

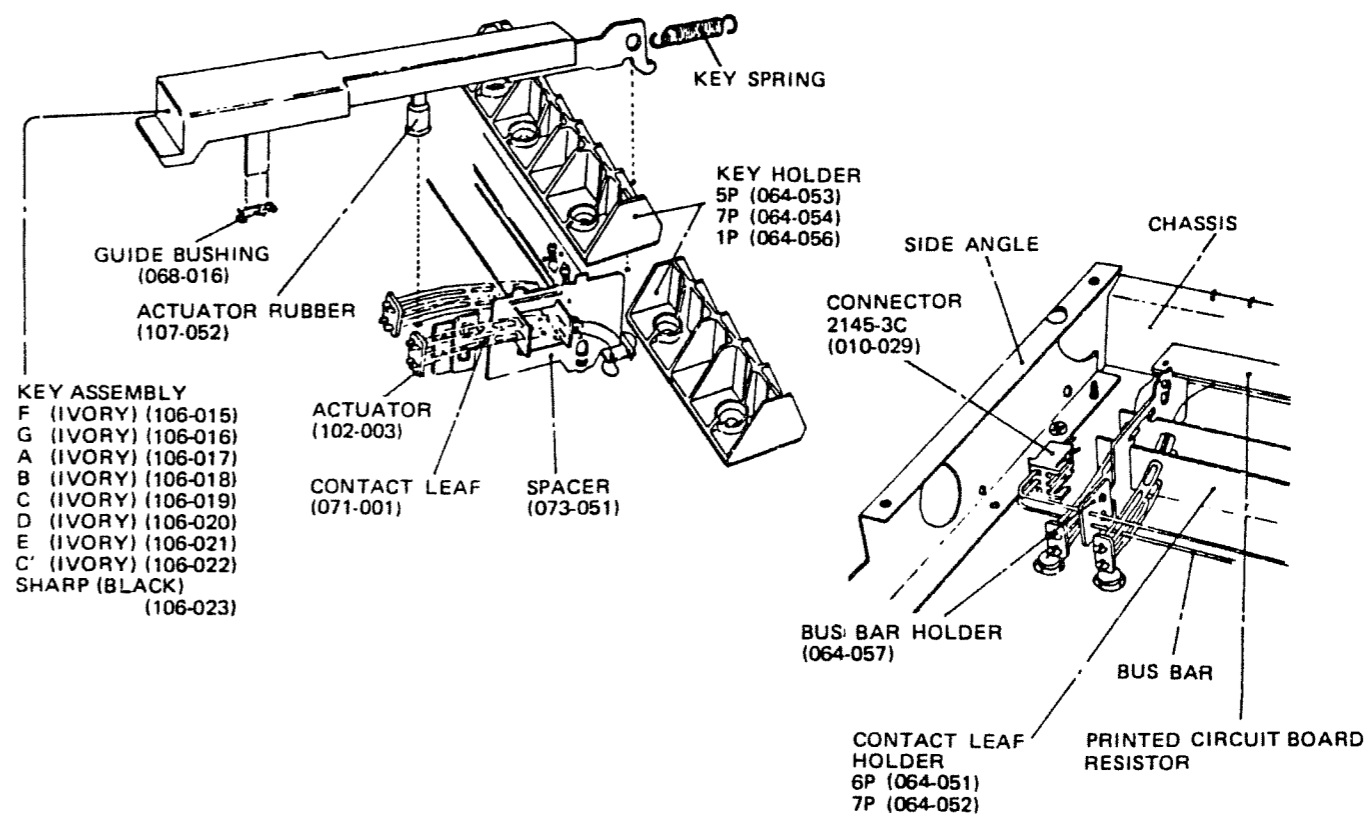

When ordering PCB, suffix an alphabetical letter to the part number referring to the Parts List and PCB Wiring Layout.

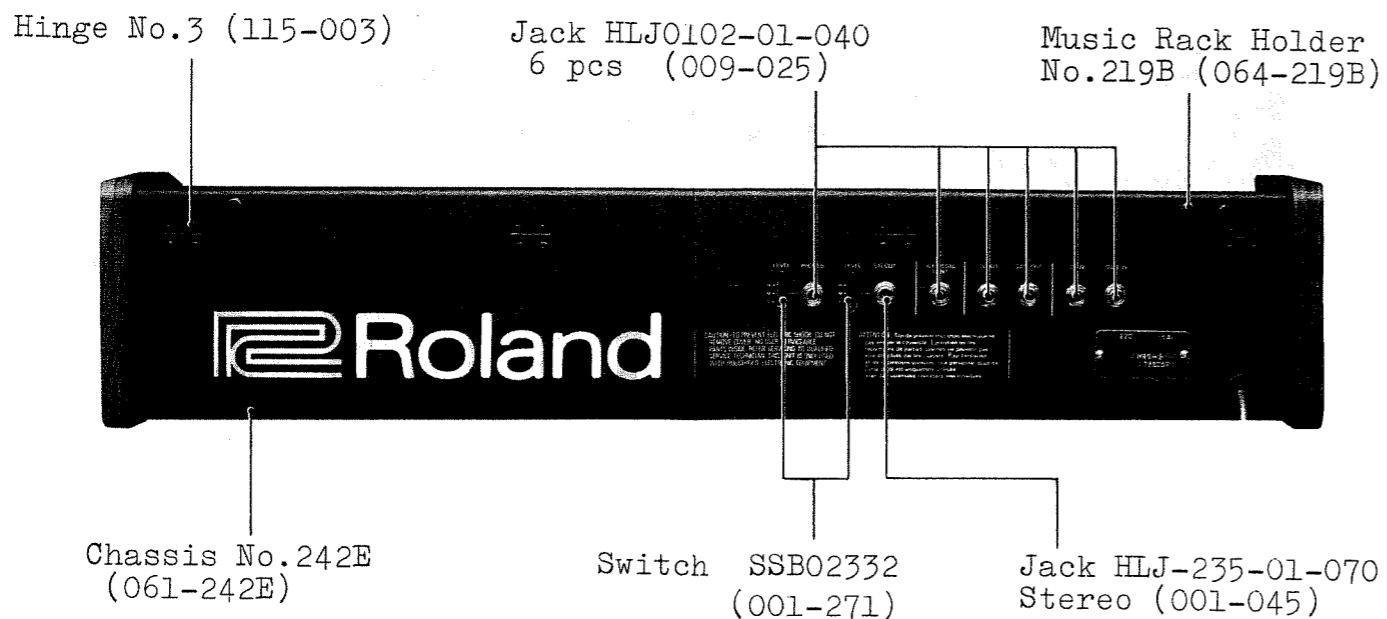

INSTRUMENT MODEL	NO. OF KEYS	KEYBOARD MODEL	KEY SPRING	BUS BAR	PCB		RESISTOR
					6P	7P	
SH-1	32	SK-132-D	070-052	071H034	052-066	052-067	100 1/4W +1% CRB1/4FX
SH-3A	44	SK-142-A	070-052	071-008	052-066	052-067	100 1/4W +1% CRB1/4FX
SH-5	44	SK-142-B	070-052	071-008	052-066	052-067	100 1/4W +1% CRB1/4FX
SH-7	44	SK-142-C	070-052	071-008	052-066	052-067	100 1/4W +1% CRB1/4FX
SH-2	37	SK132H	070-052	071-006	052-066	052-067	100 1/4W +1% CRB1/4FX
SH-1000	37	SK-132-A	070-052	071-006	052-066	052-067	1K 1/4W +2%
SH-2000	37	SK-132-B	070-052	071-006	052-066	052-067	1K 1/4W +2% SELECTED
VP-330	49	SK191-B	070-058	071H043	052-081	052-082	
SYSTEM-100	37	SK-132-C	070-052	071-006	052-066	052-067	100 1/4W +1% CRB1/4FX
SYSTEM-700	61	SK-162-C	070-058	071-007	052-066	052-067	100 1/4W +1% CRA1/4FX
MRS-2	37	SK132G	070-052	071H006	052-066	052-067	100 1/4W+1% CRB1/4FX
RS-101	61	SK-161-A	070-058	071-007	052-081	052-082	
RS-202	61	SK-161-A	070-058	071-007	052-081	052-082	
RS-505	49	SK-192-A	070-058	071H043	052-081	052-082	
EP-10	61	SK-162-A	070-058	071-007			
EP-20	61	SK-162-A	070-058	071-007			
EP-30	61	SK-162B	070-058	071-007	052-081	052-082	

CIRCUIT DESCRIPTION

What is Compu-Phonic Synthesizer?
(Features of Compu-Phonic Synthesizer)

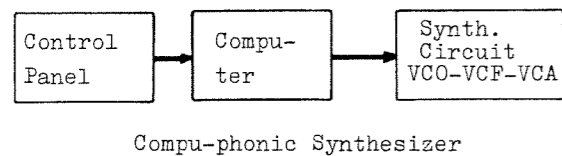
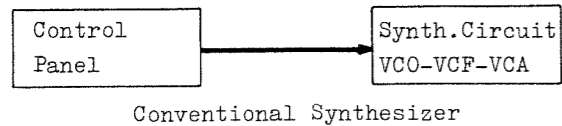

1. Operational Principle:

In the conventional synthesizer, the circuits (VCO, VCF, VCA, etc.) are directly controlled from the control panel.

In the compu-phonic synthesizer, it is the computer that comes in between and provides control voltages suitable to those VCO, VCF, VCA, ENV GEN, etc.

2. Hardware:

Compu-Phonic Synthesizer is composed of the "Synthesizer Control Circuits" with μ PD8048 as its central point and the "synthesizer circuits" which are fully controlled by voltage.

2-1. Control Section:
- Switches and Sliders -

Sliders and switches on the control panel are now not for the production of the synthesizer control signals directly, such as the production of the time constants, ON/OFF switching, etc. They now serve only to letting the computer know of their positions or the states as they are put on the Control Panel.

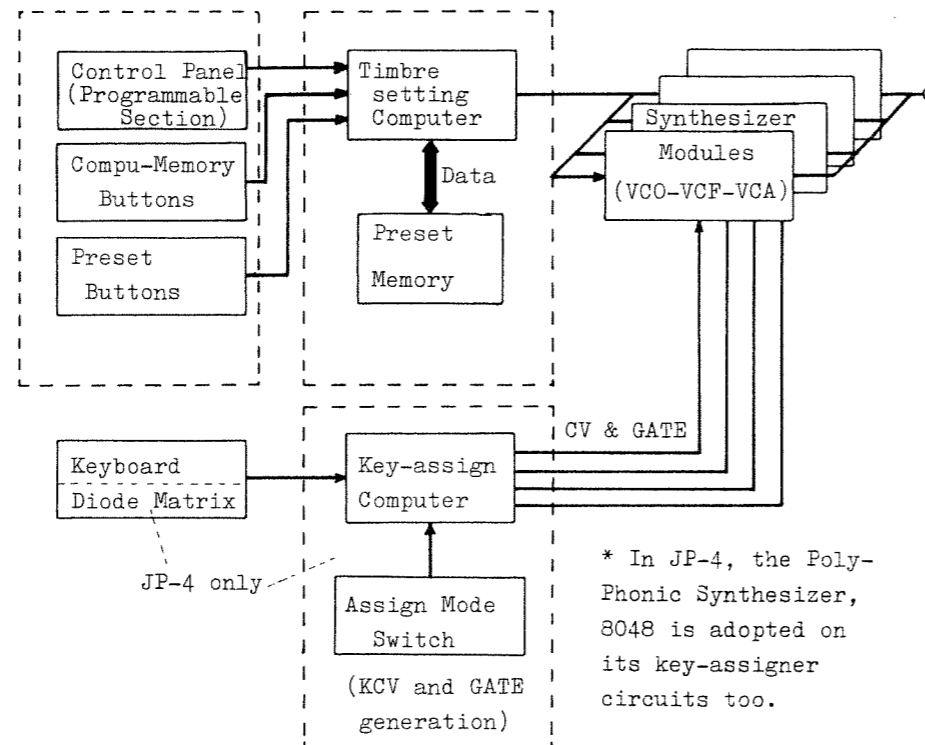

2-2. Voltage Controlled Synthesizer Circuits:

Such parameters as the time constant, ON/OFF switching, or their signal levels, etc. have so far been produced on the control panel there are sliders and switches to obtain directly of such.

These are, however, now produced by the computer's internal circuits, and the synthesizer circuits are under fully voltage controlled, programed and/or given by the computer, with self-contained transconductance amps or analog switches, etc. However, the circuit and function themselves of VCO, VCF, VCA etc. of the synthesizer's main circuits are just as the same as before with those on the conventional synthesizer.

Function of

Mother Board

In the Mother Board included are the microcomputer 8048-012 and its peripheral circuits. (refer to the General Block Diagram when reading the following)

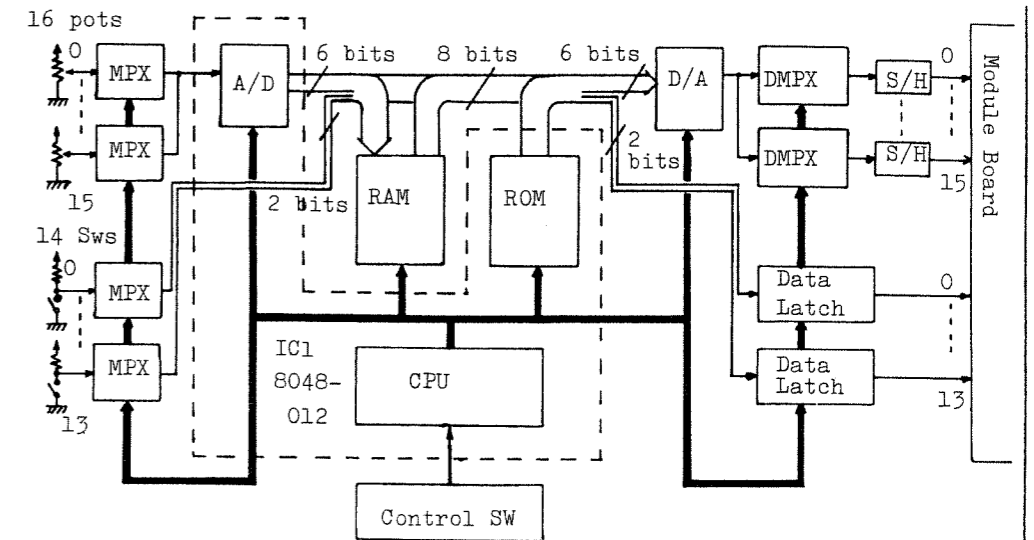

Mother Board Block Diagram

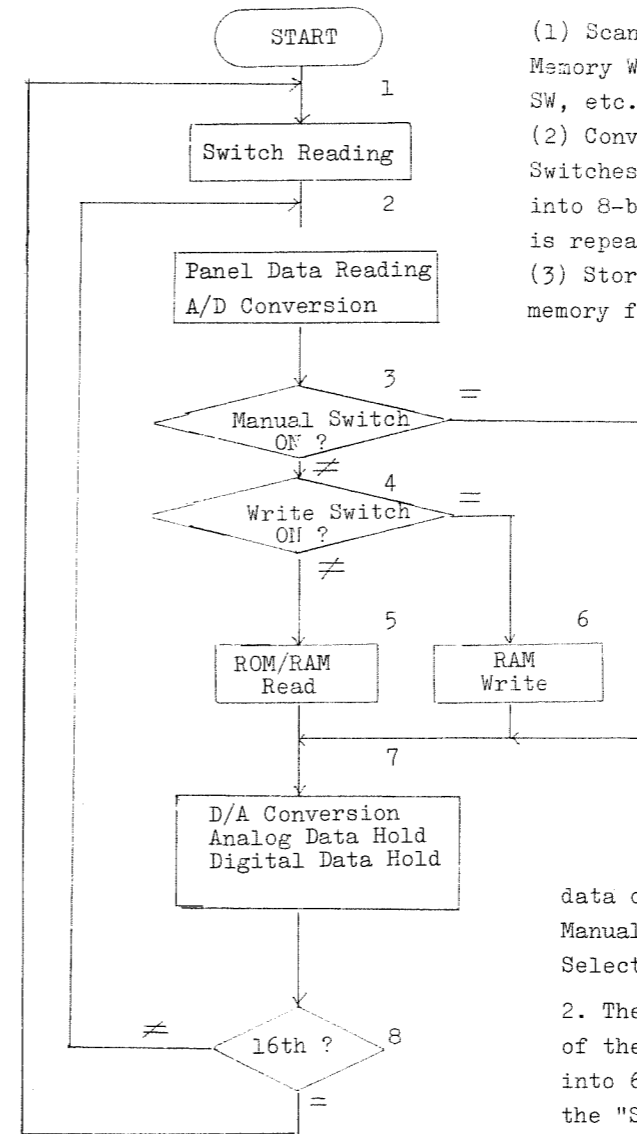

8048-012 Flow Chart
(JP-4, PROMARS)

- (1) Scanning of all the switches on the Control Panle such as Memory Write SW, Manual SW, Compu-Memory SW, Pre-Set Selection SW, etc.
- (2) Converting the Analog signals obtained from Sliders and Switches of the Programmable Section on the Control Panel, into 8-bit digital data (A/D conversion). (This data reading is repeated 16 divided times to complete them all).
- (3) Storing these A/D converted data of the POTs and SWS into memory for use afterward upon retrieval.

- (4) Converting back again these digital data into analog voltage (D/A conversion) to send them out into Synthesizer Modules. All these functions stated above are performed under the control of 8048-012.

-Functions of 8048-012-
(Tone color setting controller)

These operations of 8048-012 are shown in the flow chart. The 8048-012 repeats such flow chart cycle. The following numbers refer to those in flow-chart.

1. When the power is turned on, 8048-012 starts its reading and puts into memory the data of the positions it reads of Memory Write Switch, Manual Switch, Compu-Memory Selection Switch and Preset Selection Switch.
2. The 8048-012 takes in at first the voltage data of one of the "Slider pots" on the Control Panel and converts it into 6-bit digital data. At the same time, it reads out the "Switch Position" on the Control Panel and converts it, too, into 2-bit digital data. The two data thus obtained are combined to make a total 8-bit data. These are held there for a while.

CIRCUIT DESCRIPTION

3. If the MANUAL Switch was OFF at step 1, the program proceeds to step 4, or if ON, to 7. During this process, the data obtained in step 2 is maintained.

4. When the Memory Write Switch was OFF at step 1, the program goes to step 5, if ON, to 6. The step 2 data is still maintained.

5. Based on the data being held in step 2, the 8048-012 accesses to either RAM (Random Access Memory) when a switch in Compu-Memory was pushed in, or ROM (Read Only Memory) when one of Preset Switches was in. It then reads out from the address corresponding to the switch depressed, the data to give control to the Synthesizer Modules.

6. Based on the data in step 1, it writes the data held in step 2 to RAM, selecting the address over there which is corresponding to the switch position on the COMPU-MEMORY SWs.

7. The 8048 divides the 8-bit data (data in step 2 or data retrieved in step 5) into two formats: 2-bit switch data and 6-bit slider data. The 6-bit data then proceeds to D/A conversion. Those two signals of analog converted voltage and of switches are fed to the Module Boards.

8. The 8048 checks to see whether it completed all 16 cycles to read out all data divided into 16 at the previous stage. If all are completed it goes back to step 1. If not, to 2.

-Switch Reading-

The 8048-012 scans the matrix made of the diodes and switches on the Control Board F to find out which switch is depressed among those of WRITE through MEMORY PROTECT.

1. Diode-Switch Matrix

On the Control Board F, Switches (each accompanying diode) are grouped into 4 blocks consisting of 2 to 8 switches. These blocks are then connected through the data bus to DB0, DB3, DB4, DB6 on 8048-012. The blocks are also routed through to the pins of P20-P27 on Port 2 of 8048-012. They are then making a matrix. (refer to the Circuit Diagram, Control Board F)

2. To Scan the Switches

The 8048-012 outputs "L" onto DB0 alone and "H" on all other DB1-DB7. They are out on the data bus and latched on IC7, IC8, 74LS175 by the pulses from pin ALE (Address Latch Enable) to be output onto D0-D6 of TSET.

Next, 8048-012 reads the Port 2 (P20-P27). If it finds here that the P20 alone "L" while all others on "H", then it can know of that the SW1 is on.

The above process is repeated to go over all of DB0 to DB7, but four of them are connected to switches.

MEMORY WRITE Switch (SW1) is so wired that it is only enabled when Compu-Memory selection switch is ON with the PROTECTION switch (SW21) being depressed at the same time.

(see circuit diagram, CONTROL BOARD F)

- Reading of CONTROL PANEL -
The PROGRAMMABLE SECTION

The 8048-012 reads the patching on the Control Panel and converts them into digital data of 16 bytes. (1 byte = 8 bits)

Of the Control Panel, the section named "PROGRAMMABLE" consists of 16 pots and 14 switches, these 16 pots produce 16 different kinds of analog voltage varying between 0V to 5V. The 14 SWs, on the other hand, produce binary digital data of "H" or "L", given by +5V or 0V, respectively. The 16 analog voltages that come in parallel to each other are re-arranged thru the analog multiplexer (MPX) IC5, IC6 4051, to be put on a single line in time sequence.

These outputs of the MPX go into the A/D converter (will be described later) to become 6-bit data of 16 kinds.

The 14 binary data of the switches are also re-arranged into 2 groups of 7 kinds (total 14) with each group entering each respective MPX IC3, IC4 where they are made to 2-bit data and be output from there in time sequence as above. These 6-bit and 2-bit data are combined to become an 8-bit data. That is to say, that, the patching first made on the Control Panel are become to be represented by all digital data of 16 bytes in all. (refer to Memory Map on page 13)

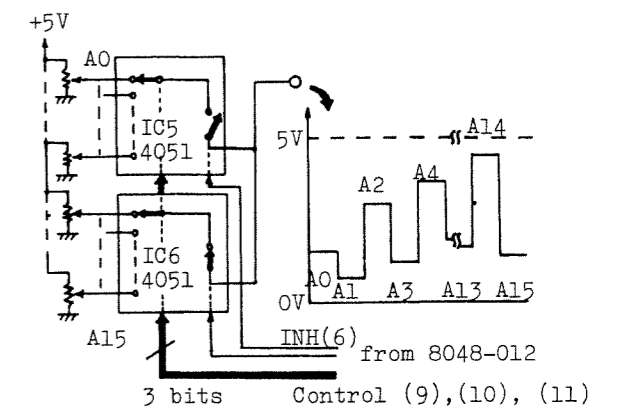

Multiplexer

IC5, IC6, 4051 can be regarded as the same to a rotary switch provided with one more switch on itself as shown above.

Port 1 of 8048 outputs both the Address signal (Control A, B, C, Pins 9, 10, 11), which also serves as switch for 4051 itself for INPUT/OUTPUT Address data, and Chip Enable Signal (INH, Pin 6).

(There are 4 of 4051. Pins 9, 10, 11 of all four are connected through the same lines)

- D/A and A/D Conversion -

1. D/A Converter

The D/A Converter used on the Mother Board is the one called "R-2R type". The converter here is only making use of higher significant 6 bits among those of 8 bits given here, leaving the least significant 2 bits unused.

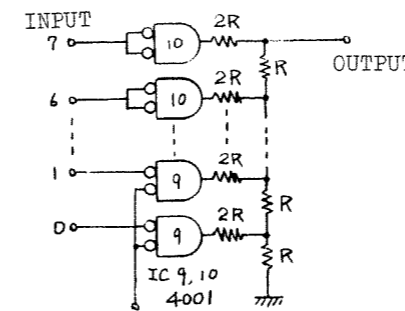

D/A Converter

2. A/D Converter

The A/D Converter on the Mother Board is referred to as "Successive Approximation Type Converter" which make use of the D/A converter and a comparator. To proceed on with conversion, 8048-012 starts deciding the data at first for the most significant bit, then down to those lesser significant bits. IC9, IC10 serve as an inverter, making the input to follow negative logic. The output is +5V maximum, therefore, when it receives the input LLLLLLXX, or 0V minimum when HHHHHHXX. (XX are for those least significant bits that are made nil.)

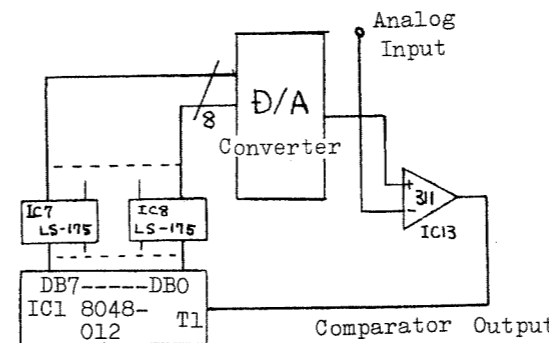

A/D Converter

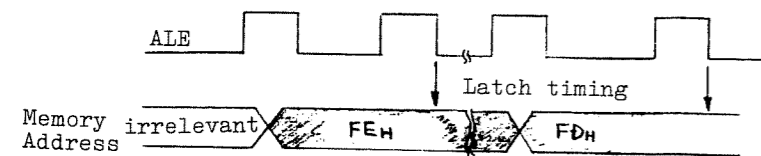
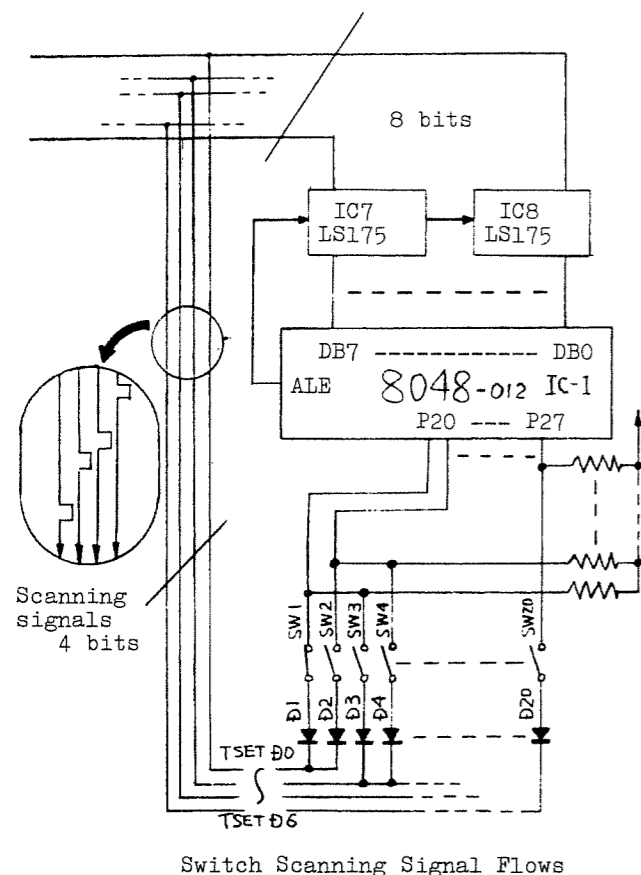

DB Data Latch Timing

(Numbers 1-6 below in this section refer to those at top in figure right)
 The 8048-012 tries at first putting DB7 to "L", thus making the digital data at first to LHHHHHXX, tentatively. These are latched on LS175 by the pulse from ALE pin, then out onto the D/A converter. On the one hand, 8048-012 reads the output level of the comparator, IC13 311, through T1 pin. It makes comparison between these two, of the A/D input and of D/A converted output to LHHHHHXX (= 2.5V). If the A/D input is to be as shown in figure (a straight line a little over 2.5V), the comparator finds that the D/A converted output LHHHHHXX(2.5V) is less than that of A/D input. It is to instruct 8048 to decide that the "L" previously put on tentative base can be firm so that "L" is to remain on DB7 hereafter. Now, 8048 turns to DB6 in putting here again "L" tentatively, to output LLHHHHXX. With this data, the D/A output becomes higher than the A/D input as in step 2 on figure. It makes the output of the comparator 311 turn to "H". That means, that 8048 has now to decide that DB6 in "L" is too large, so it must be reset back to H again. The same process continues through the lesser significant bits, as on step 3-6 on figure.

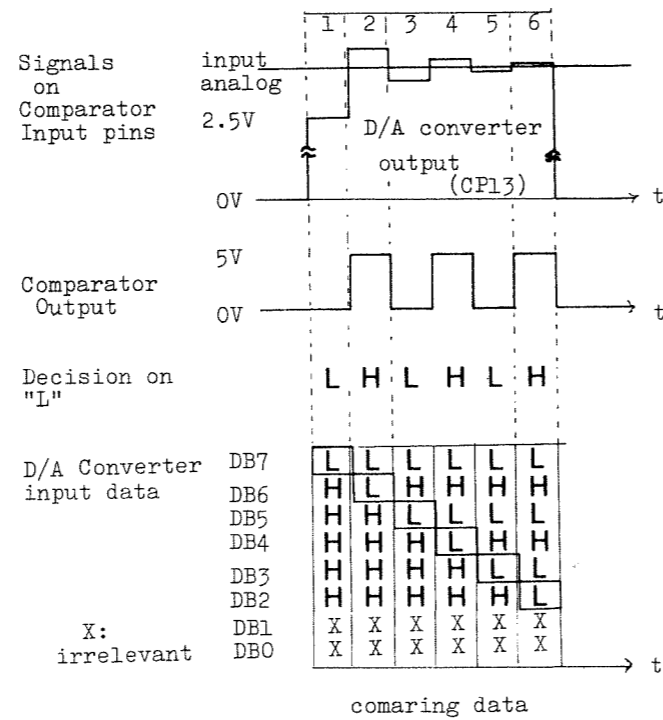

Input:Data Comparison

Each time, the D/A output approaches successively nearest to the A/D input voltage. And finally, when 8048 completes them all for DB7 to DB2 for bits, it has decided the data on the nearest approximation to be equal to that of input of the A/D converter.

- Memory -

Here provided on this Compu-Phonic Synthesizer are "CMOS RAM", IC2, 5101 for memory of the tone color (timbre) data to be used on Compu-Memory and ROM which resides in 8048-012 for use on PRESET mode.

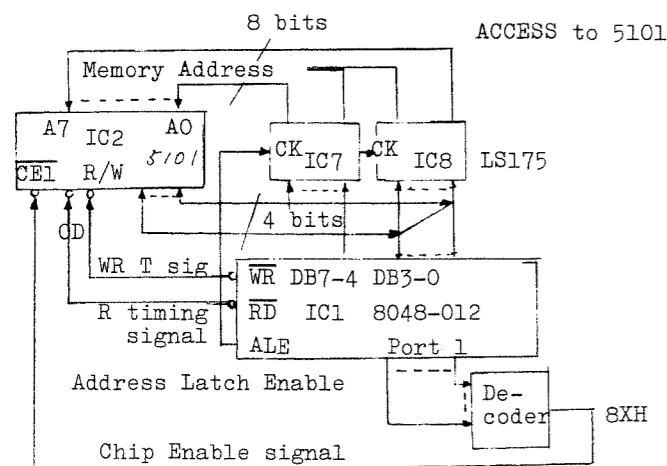

8048-012 outputs from Port 1 the address data to turn the Chip Enable (CE1) to "L" on 5101. Then, 8048-012 outputs the pulses from ALE pin to make LS175 (IC7, IC8) latch the data and define the memory address upon 5101. While the memory address being defined by LS175, 8048-012 outputs onto DB0 to DB3 the data to be written. These data are then written onto 5101 by turning \overline{WR} to "L", and are read by 8048 through DB0 to DB4 when \overline{RD} is "L". The digital data on the Control panel are 8 bits format. However, when made access to 5101, they are divided into 2 by 8048-012. (Because 5101 handles 4-bit quantities.) 5101 is backed up by the NiCd battery for protection of its memory. The NiCd battery will be fully recharged for more than 48 hours. The memory on 5101 are also protected for an hour by the electrolytic capacitor (1000mfd 6.3V) just in case when the battery is removed for replacement or other.

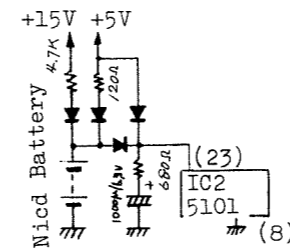

DC Supply for 5101

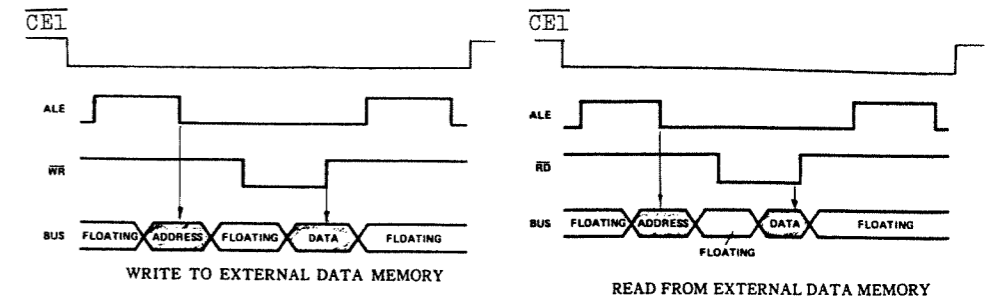

5101 READ/WRITE CYCLE

-- GENERATION of CONTROL SIGNALS to MODULE BOARD(S) --

The control data that were A/D converted to kinds of analog voltages and 14 kinds of binary 8-bit digital data are re-converted to 16 signals before they are sent to the Module Board(s).

1. The 8048-012 reads out these digital data of 16 bytes successively from RAM or ROM. Upper 6 bits (DB7 to DB2) among them are made to analog voltage thru D/A converter and are put on a single line in time sequence and are sent to 16-output analog demultiplexer, DMPX IC31, IC32, 4051.

DMPX here is to separate the input data into 16 at the control signals from 8048-012 (IC31, 32, pins 6, 9, 10, 11). They are held at TLO82, IC22 through IC29 to be sent out to the Module Controller and the Module Board.

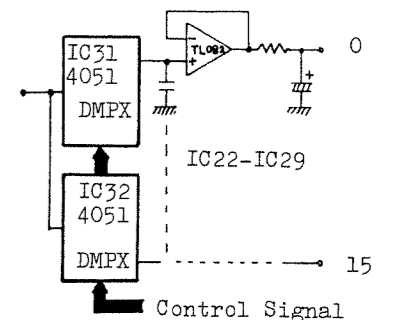

DMPX & HOLD circuits

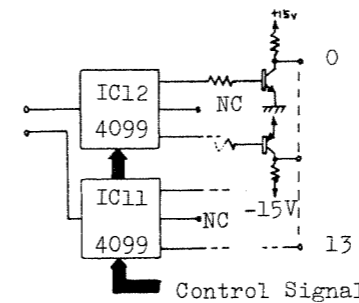

Level Shift Circuits

2. The lower 2 bits data, DB1, DB0 are fed in time sequence to the input pin of each respective address data latch 4099, IC11, IC12. The two 4099s latch them in separate 7 groups under the control signals from 8048-012 (to pins 4, 5, 6, 7). The outputs of 14 kinds go into the level shift circuit following 4099 where they are shifted into levels each suitable for the purpose to each. (Section surrounding Q3-Q14.)

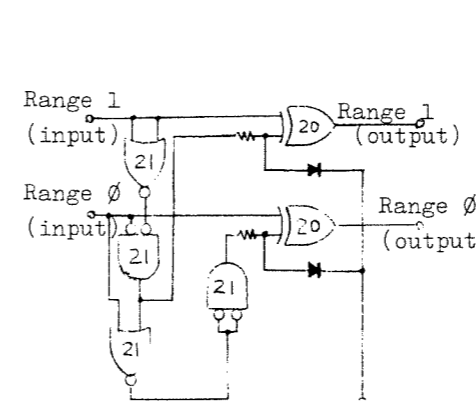

Transpose Subtractor

3. Of the 14, those of VCO-WAVE 1, \emptyset and LFO-WAVE 1, \emptyset are fed to the Wave form selector, IC19, IC20 and LFO Select Decoder, IC33, IC34 to receive each respective decoding. VCO-RANGE 1, \emptyset go into Transpose Subtractor where the contents of the 2-bit data of RANGE 1, \emptyset are converted when the Transpose Input is

Transpose by the Subtractor

TRANSPOSE	H	L	H	L
RANGE 1	RANGE 1	RANGE 0	RANGE 1	RANGE 0
32'			L	L
16'	L	H	L	H
8'	H	L	H	L
4'	H	H		

turned to "L" Refer to Table for what conversion is meant on this transpose. In effect, it is to go down by 1 octave on VCO range as shown by arrows. Thus, the Switch control signals in 14 kinds become to control the Module Boards after passing through these circuits as above.

- OTHERS - Reset Circuit

The circuit is to protect 8048-012 from running program inadvertently. When RESET pin 4 is turned to "L", it makes 8048-012 to reset back to the initial state. This is also connected to 8048-011 through the common line. (8048-011, JP-4 only)

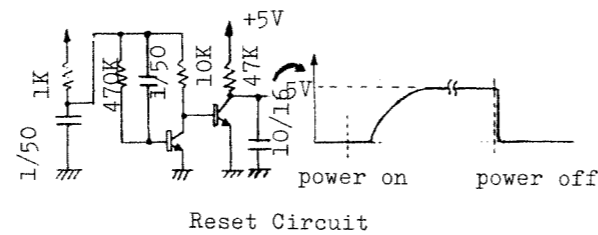

- MODULE BOARDS -

Included here are VCO, VCF, VCA and 2 ENV GENERATORS.

1. VCO and its Peripherals

IC1a(pin 1,2 and 3) makes the vibrato voltage VCO CONT and keyboard key voltage KCV mixed and sends them out onto the antilog transistor IC2 which outputs antilog current from pin 9. This antilog current is then compared at the Comparator IC5b(pin 5,6,7) with the current flowing in from pin 6 of IC4 thru R118.

The output of the comparator IC5b is made to control the VCO generator oscillation frequency produced from IC4, Gate IC. Here, however, the VCO has to make the oscillation in such frequency that it always keeps the difference at zero in values between the current I_g from pin 6 of IC4 and the antilog current I_{exp} from the antilog IC2.

The VCO outputs are in the pulse form of the constant width converted by the one shot multivibrator IC3(555).

It is therefore necessary to double the number of pulses if the antilog current is doubled. IC5b watches this to keep the balance at this pin 6. And, if losing the balance, it sends an additional voltage onto VCO to make it regain the balance. These are the process how to output the frequency which is antilog-proportional to the input voltage. The pulse output here is of so narrow width as yet. It is necessary therefore to provide further wave conversion. IC6 is a frequency divider. IC7 is a multiplexer to make selection from those divided frequency,

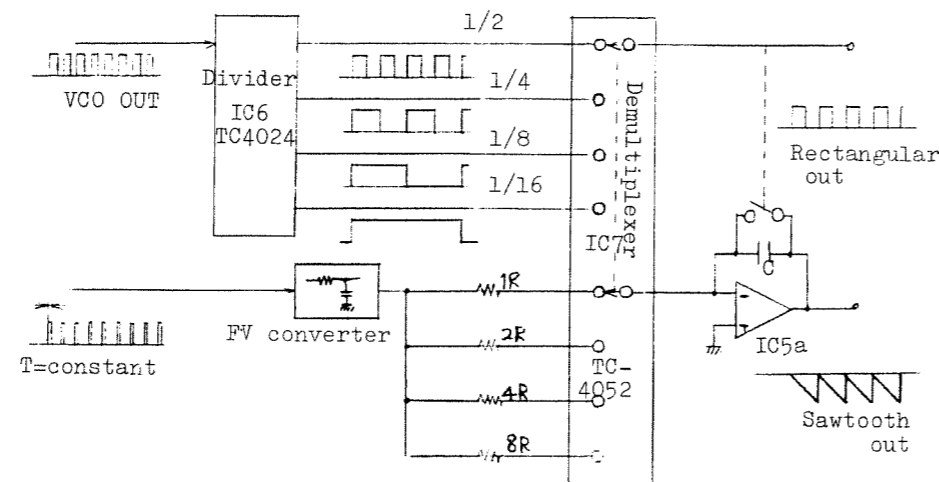
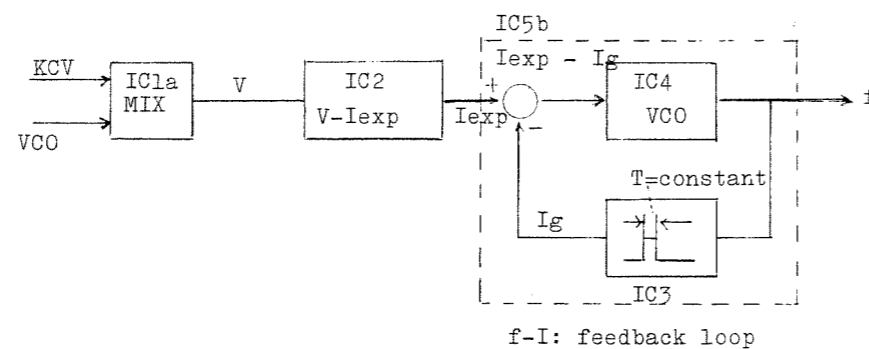

IC5a generates sawtooth waveform synchronized to that of the selected frequency. The amplitude of the sawtooth waveform is kept constant by choosing either of R18-R24 by the multiplexer IC7 regardless of any change made at the tone feet. On PROMARS, it has a VCO 9 Board for its 2nd VCO. This Board is in effect just as the same that the VCO section is only taken out from the Module Board stated herein.

2. VCF and its Peripherals

VCF here is not much different from those on the conventional synthesizer. IC11 is the high-pass filter. IC12-IC15 are the low-pass filters. IC17 is the circuit for setting Q for the low-pass filters.

IC18 is the electronic potentiometer to control the depth of the cutoff frequency modulation. IC19 (pins 5,6,7) is the cutoff frequency control mixer. Q8 and Q9 are the antilog current generation circuit.

3. Envelope Generator

There are two Envelope Generators, one each for VCF and VCA. They are basically the circuits to voltage-control the time or the level of A, D, S, R. Since the signals are now in the pulse form, being voltage-pulse converted on the Module Control Board, the A, D and R controls are to be achieved by controlling the number of pulses in a given time. Note that, these pulses here are of so narrow width that it may easily be lost of sight from screen on the oscilloscope if the pulse intervals were extended a little long.

IC25 is the flip-flop which inverts itself on arriving at the attack level. IC24 is the gate selecting the pulse for each of A, D, and R by the timing of the flip flop. IC22 is the analog switch which turns on only when there

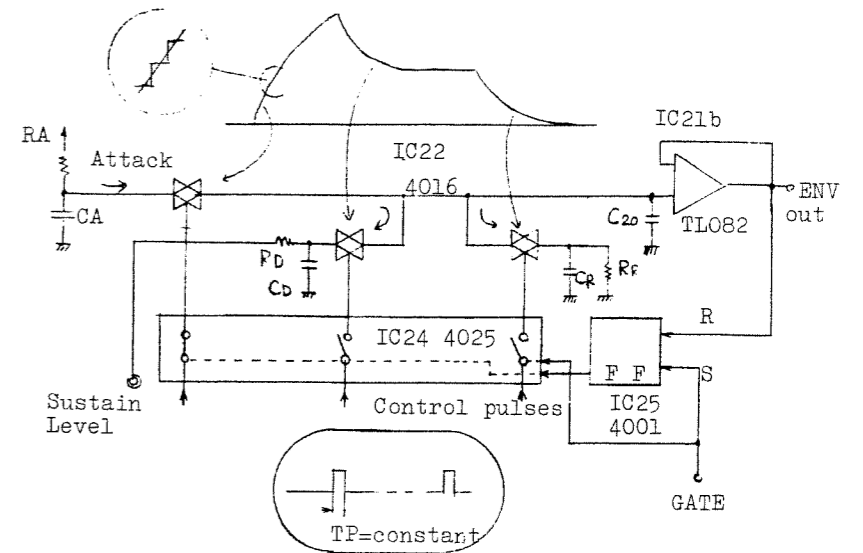

is a pulse arrival, thus making C20 to charge-discharge, accordingly. On such charge/discharge, envelopes are developed. The envelopes from C20 are fed through buffer IC21 to obtain low output impedance.

- MODULE CONTROLLER -

Module Controller Board is to control those on Module Board as follows:

- VCO modulation
- VCF modulation
- VCA modulation
- Generation of the clock signals to control ENV GEN.
- Cutoff frequency of HPF
- Pulse width modulation of VCO

The Module Controller performs these functions by converting the control signals fed from the Mother Board or those fed from the Bender Board into such signals to suit for controlling the modules. Here also included are the Noise Generator and LFO Delay Circuit.

MOTHER BOARD TIMING DIAGRAM in MANUAL MODE (SLIDER/SWITCH READ/HOLD, A/D & D/A CONVERSIONS, MPX and DMPX)

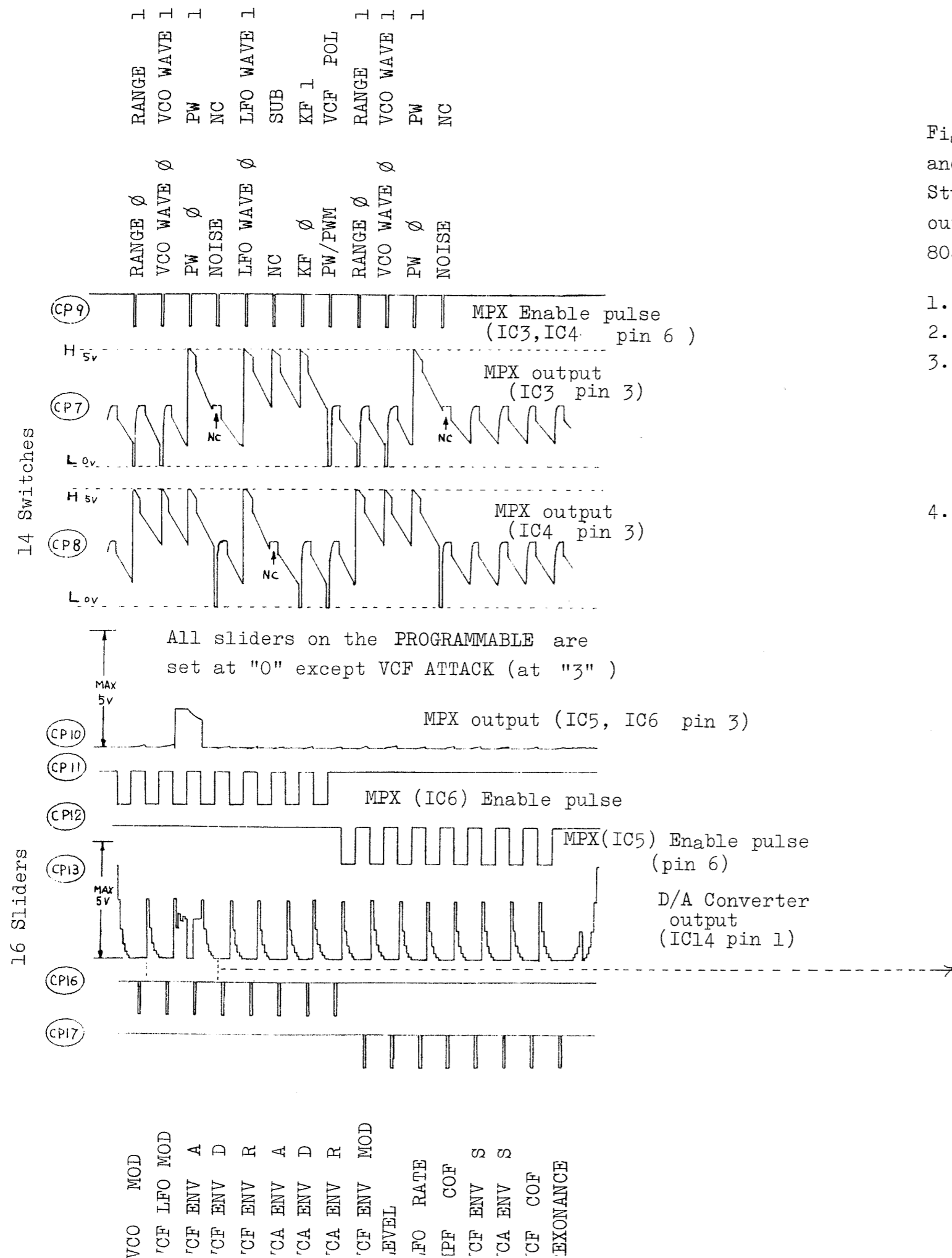
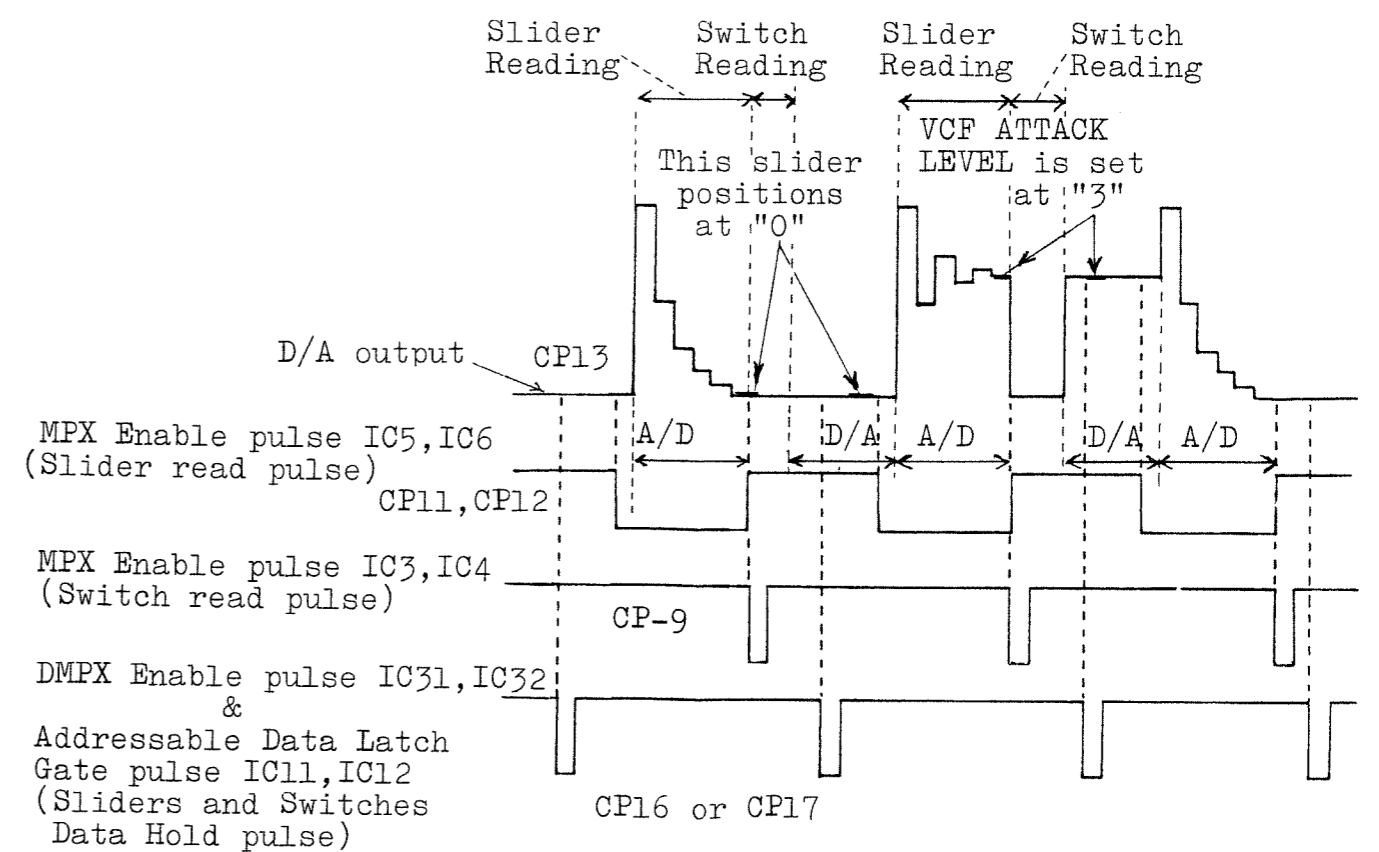

Figure below is part of CP9, 11, 12, 17 and 13 at the left showing functions and timings of A/D, D/A conversions and the Switch reading. Studing D/A conversion theory on the Mother Board by observing the converter output waveform is very helpful in understanding the operation of microcomputer 8048-012.

1. The computer 8048-012 reads Sliders set positions through A/D conversion.
2. The computer reads, between A/D and D/A conversions, Panel switches status.
3. In Manual Mode, at CP13, final of A/D and D/A outputs are equal in level. This means that Panel Data are fed into Synthesizer Modules as they are. However, in other modes, A/D and D/A show different values because they are out of relation to each other, D/A converter transforms digital data from the memory.
4. During D/A conversion, sliders data being D/A converted from 6-bit format and switch data from 2-bit format are held (latched) and output to the synthesizer modules.



DESCRIPTION

Signals Flow Diagram on the Mother Board

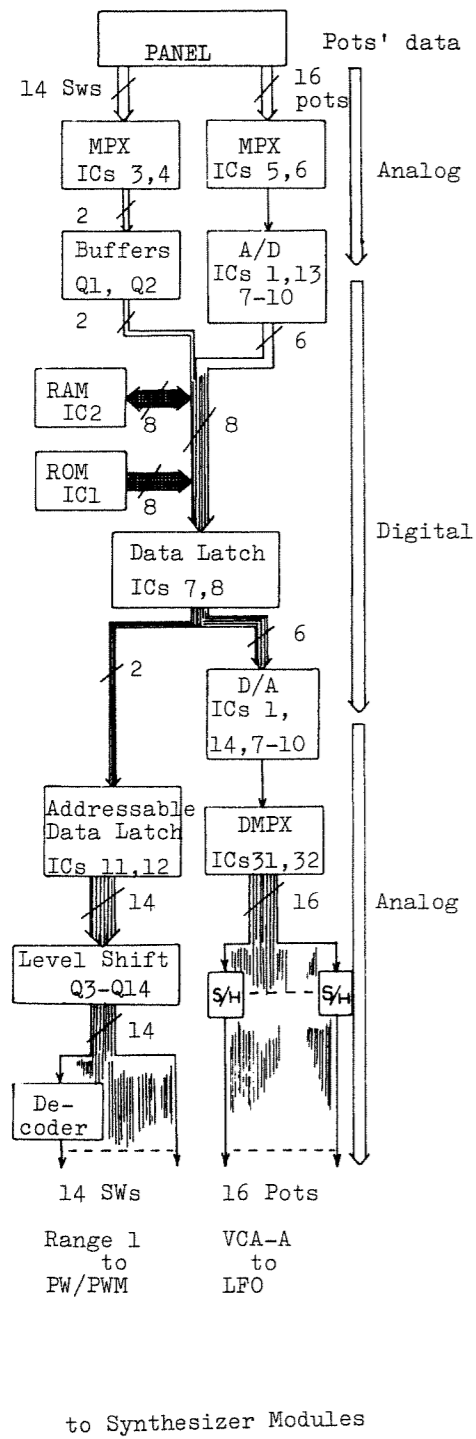

⇒ Indicate Data Flows from the Control Panel. Will be output to the Synthesizer Modules only in Manual Mode.

⇒ Show Data to/from the Memories in Compu-Memory and Preset Modes. Will not be output to the Synthesizer Modules in Manual Mode.

⇒ Common lines for the data from the Control Panel and the Memories.

DESIGNATION	PIN NO.	FUNCTION			
DB (Data Bus)	DB0	12	Panel Switches Data Panel Sliders Data Push Switches Scanning RAM address Sliders and Switches Data during RAM address		
	1	13			
	2	14			
	3	15			
	4	16			
	5	17			
	6	18			
PORT 1	P10	27	I/O address 4051: IC3-IC6, IC31-IC32 4099: IC11, IC12 5101: IC2 \overline{CE} 1 select 8048C-012 Logical Symbol		
	11	28			
	12	29			
	13	30			
	14	31			
	15	32			
	16	33			
	17	34			
	PORT 2	P20		21	Switch Scan Reading Data
		21		22	
		22		23	
23		24			
24		35			
25		36			
26		37			
27		38			
XTAL 1		2	Inputs for internal Clock Oscillator Reset pulse input Comparator output signal input during A/D conversion Memory read timing signal output Memory/Write timing signal output DB Data latch pulse output		
XTAL 2		3			
RESET		4			
T 1	39				
\overline{RD}	8				
\overline{WR}	10				
ALE	11				

(Top View)

μPD8048

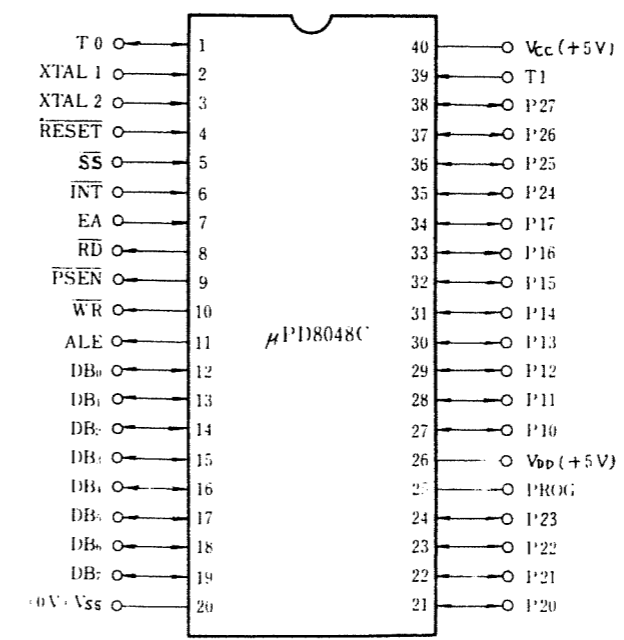

The μPD8048 is an 8-bit parallel computer fabricated on a single silicon chip. The 8048 contains a 1K x 8 ROM program memory, 27 I/O lines, an 8-bit timer/counter and clock circuits. Used in the Compu-Phonic Synthesizers are μPD8048-012 and μPD-8048-011 (JP-4 only) versions in which programs and data dedicated to the Compu-Phonics are stored in the program memories.

to Synthesizer Modules

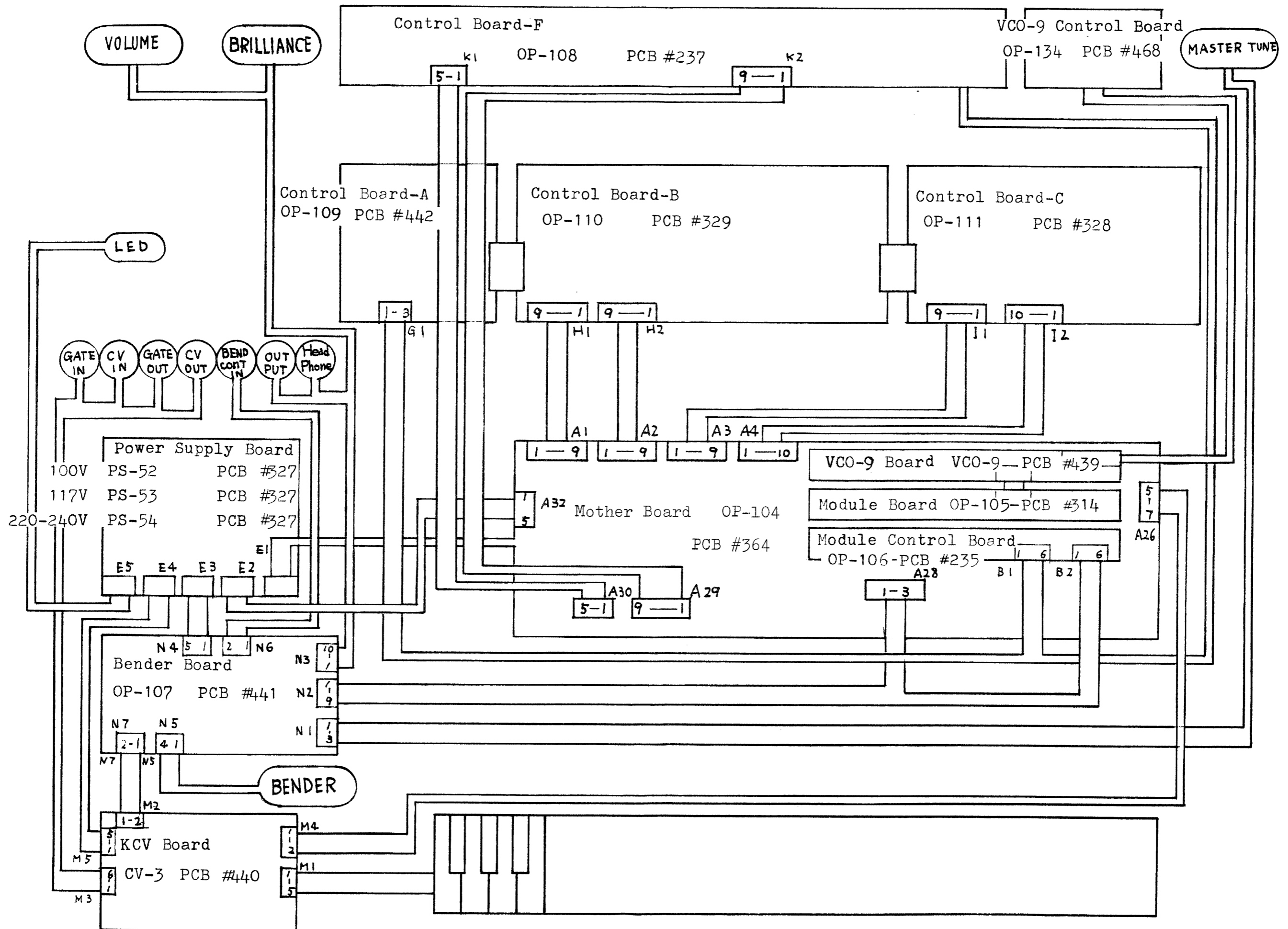

INTERCONNECTION DIAGRAM

CONTROL BOARD A

CONTROL BOARD B

CONTROL BOARD C

MODULE CONTROL BOARD

VCO-9 BOARD
MODULE BOARD

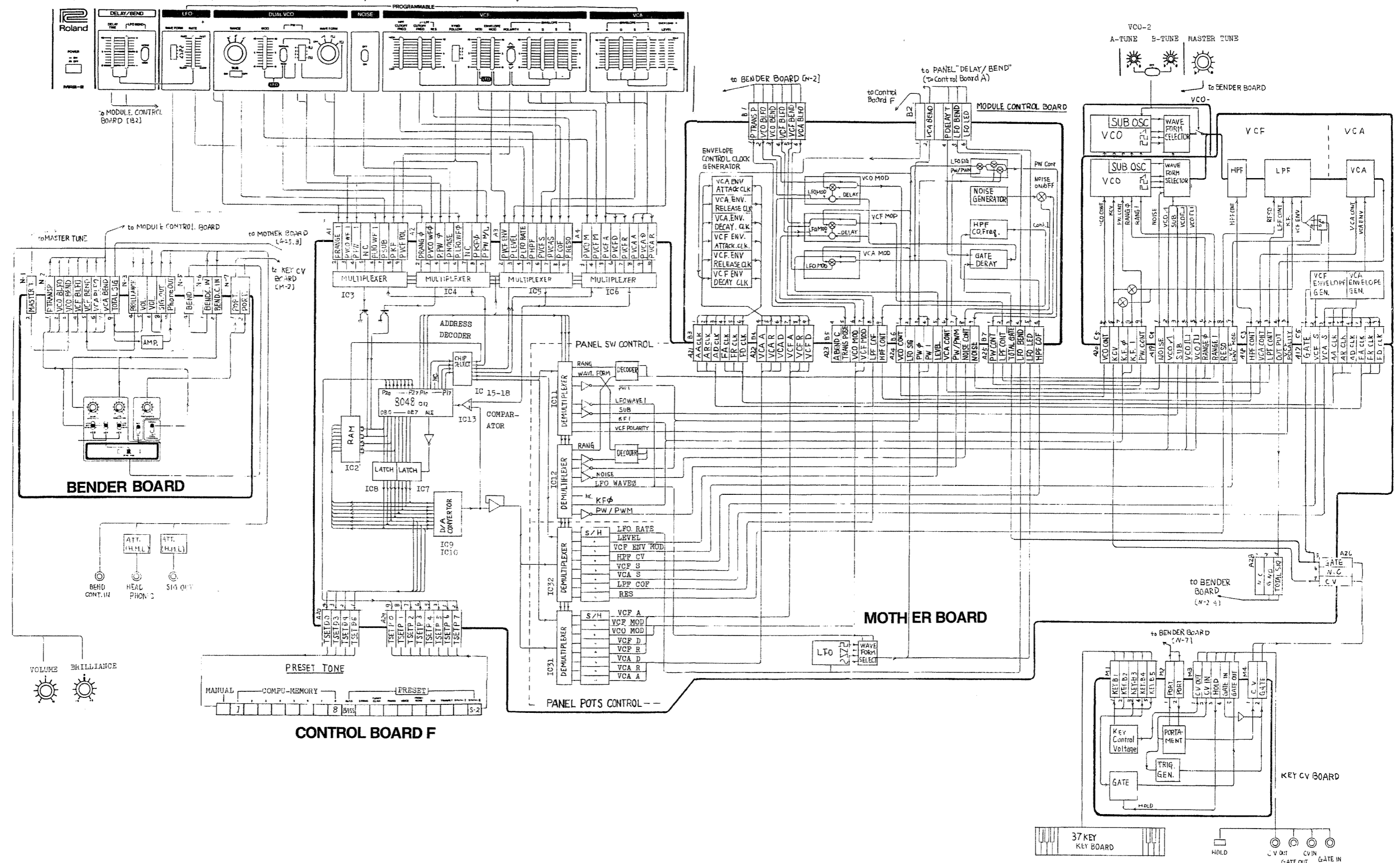

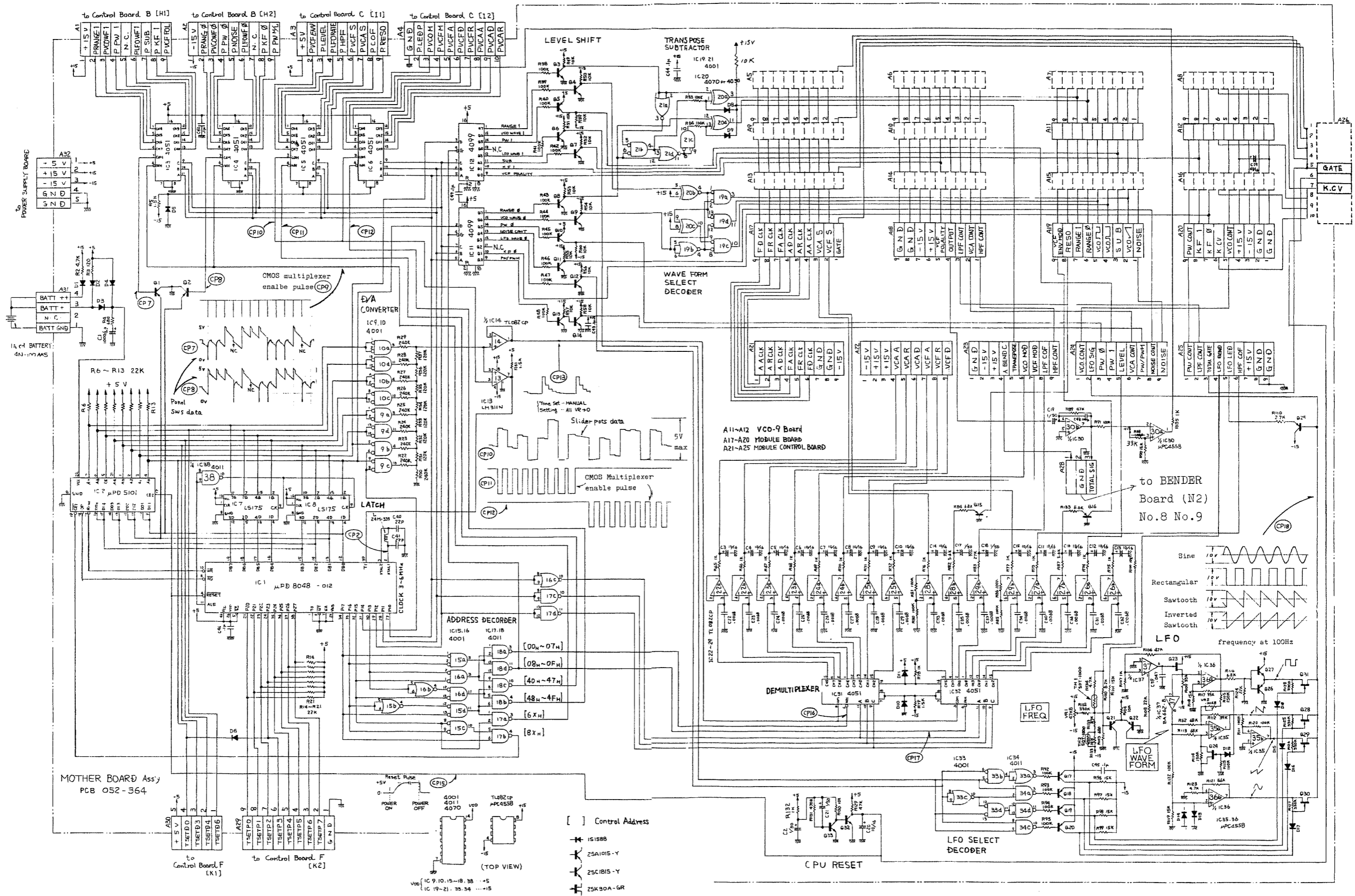

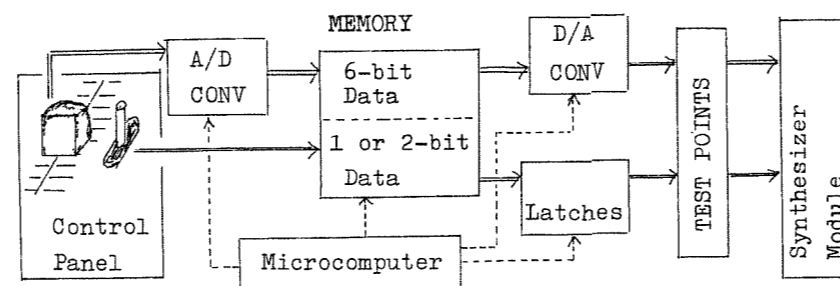
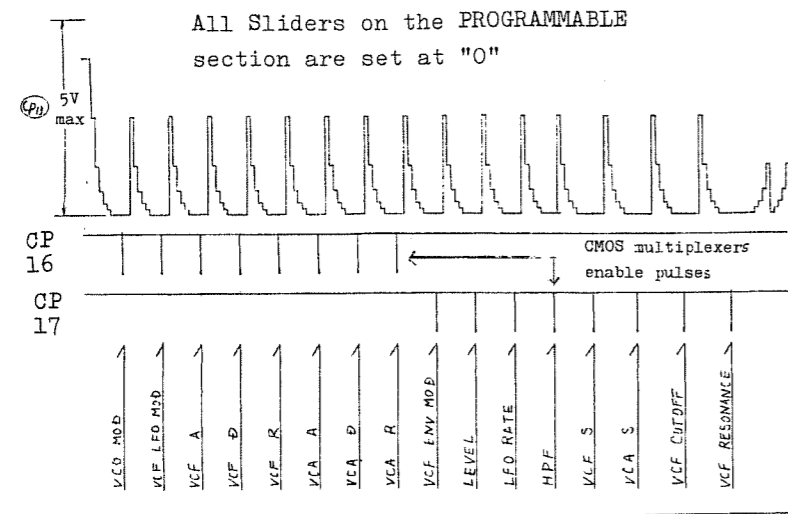

Figures in TP column in the table to immediate right and figures at top of the other tables refer to test points shown in the PCB layout below. The following applies.

1. For sliders; voltage will vary within the range of 0V to +5V as the designated slider is being moved.
2. For switches; the output will be a logical 0 (low) or 1 (high): (0V,+15V), (-15V,+5V), (0V,+5V), depending on the lever position.

TP	SLIDER
20	VCO MOD
21	VCF MOD
22	VCF ENV A
19	VCF ENV D
18	VCF ENV R
15	VCA ENV A
17	VCA ENV D
16	VCA ENV R
28	VCF ENV MOD
29	VCA LEVEL
30	LFO RATE
27	HPF C O F
26	VCF ENV S
23	VCA ENV S
25	LPF C O F
24	LPF RES

NOISE	
TP	11
OFF	0
ON	1

SUB	
TP	5
OFF	0
ON	1

VCF POLARITY	
TP	7
NORMAL	1
INVERT	0

VCF KEY FOLLOW		
TP	6	13
3	0	0
2	0	1
1	1	0
0	1	1

VCO WAVEFORM		
TP	2	9
OFF	0	0
1	1	1
1	0	1
0	1	1

PW/PWM	
TP	14
MANUAL	1
LFO MOD	0

LFO WAVEFORM		
TP	4	12
1	1	1
1	0	1
0	1	1
0	0	1

PULSE WIDTH		
TP	3	10
4/	1	1
3/	1	0
2/	0	1
1/	0	0

VCO RANGE		
TP	1	8
16'	0	1
8'	1	0
4'	1	1

MOTHER BOARD OP-104B
(Etch mask 052-364B)

IMPORTANT

In replacing the Mother board, check both the existing board and the new replacement board for existence or absence of Q15 and Q16. If different, see page 19 for modification.

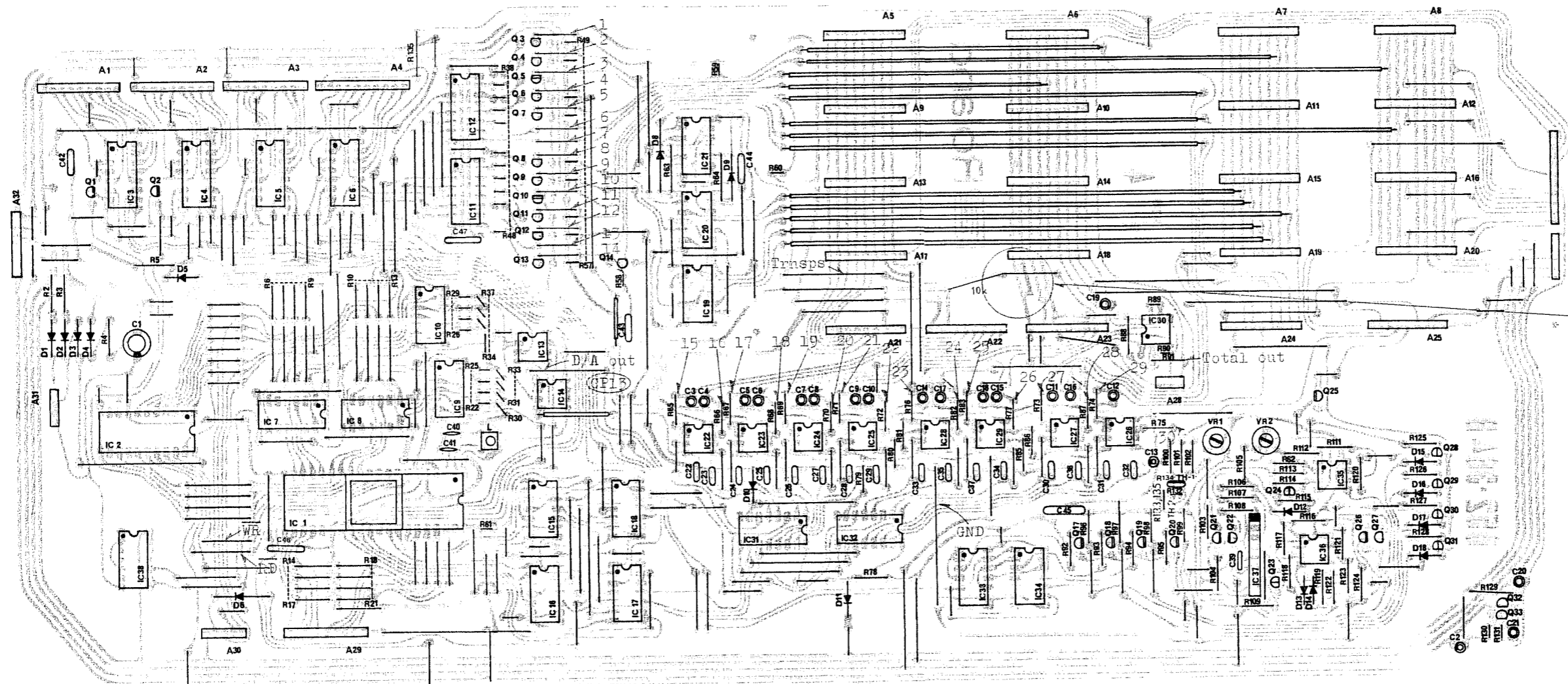

Components on foil side:

C48, C49

Connector A6, A10, A14, A18, A23 (connections to Power Supply Board E1)

BENDER BOARD OP-107B (149-107B)

View from foil side

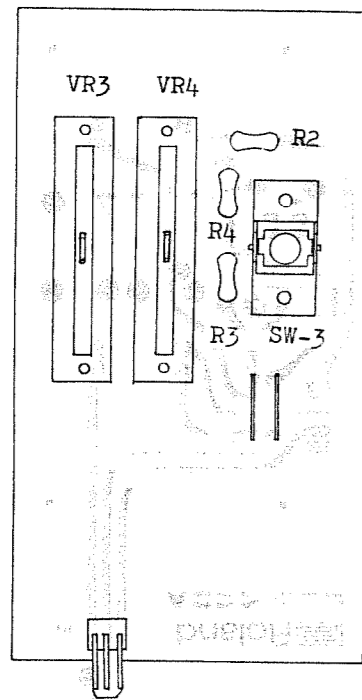
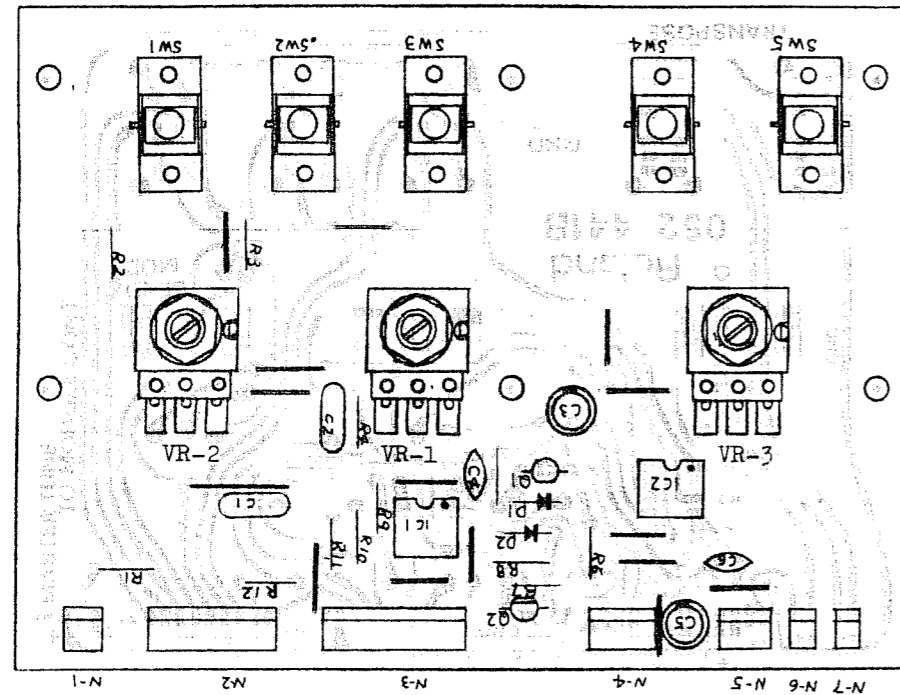

**CONTROL BOARD A-a
OP-109A (149-109A)**

View from foil side

**LEVEL SW BOARDS
I PHONES II OUTPUT
OP-112A OP-113A
(149-112A) (149-113A)
(PCB 052-443A)**

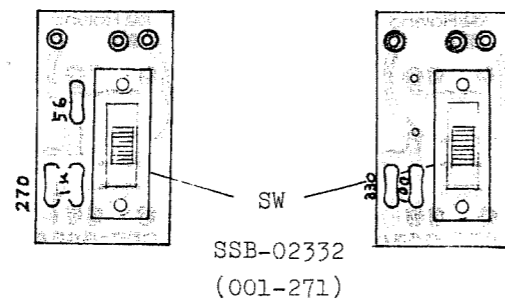

- OP-134
VRs EVH-LWAD25B15 (030-951)
SWs LBC-23M-18K (001-238)
- CONTROL A OP-109
VR3 EVA-V17C16C26 (029-370)
VR4 EVA-V23C16B54 (029-426)
SW3 LBC-42-18K (001-237)

**CONTROL BOARD F-c
OP-108C (149-108C)**
(Etch mask 052-237C)

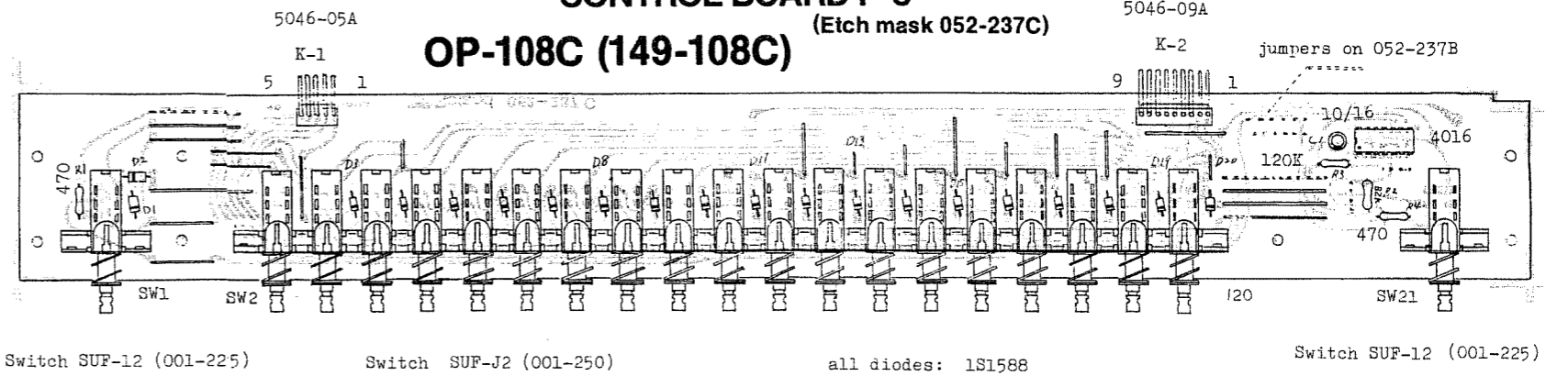

OP-107

- SW1,2,3
LBC-23M-18K (001-238)
SW4,5
LBC-42M-18K (001-237)
VR3 VM10RB10C2MAK20
(028-756)
VR1,2
VM10RB10C50KBK20
(028-762)

CONTROL B

- SW1,5
SQPR-2412P (001-228)
SW2 SSB-022 (001-182)
SW3 SRM-1034-K15
(001-234)
SW4,7
LBC-42M-18K (001-237)
SW6 SRM-1043-K15
(001-224)
All Pots
EVA-V17C16B54 (029-355)

**VCO-9 CONTROL BOARD
OP-134A (149-134A)**

View from foil side

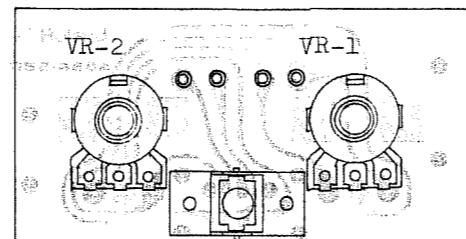

CONTROL C

- SW1 SQPR-2412P (001-228)
SW2 LBC-42M-18K (001-237)
All Pots
EVA-V17C16B54 (029-355)

CONTROL BOARD B-d OP-110D (149-110D)

View from foil side

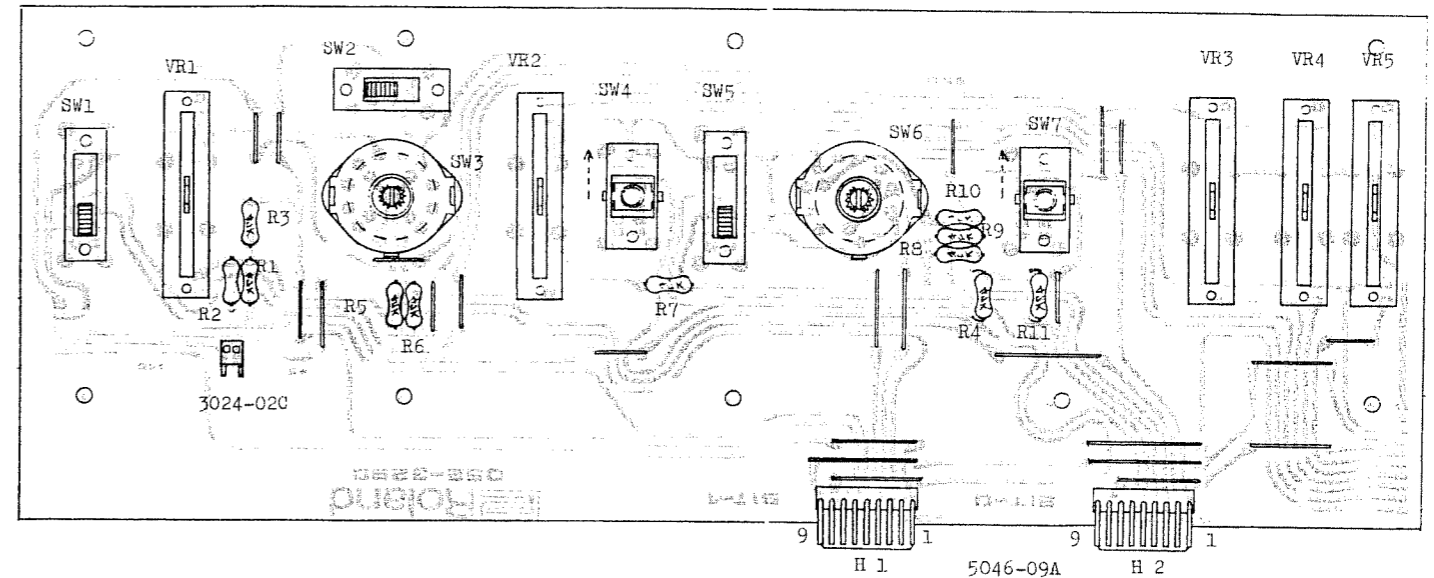

OP-111B (149-111B)

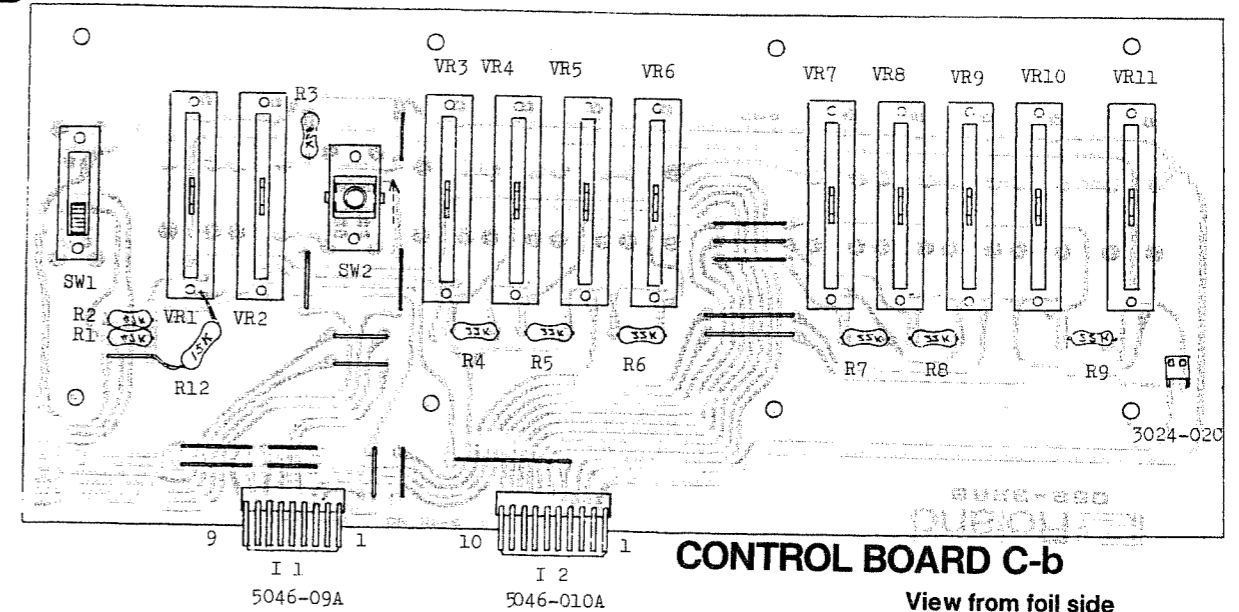

CONTROL BOARD C-b

View from foil side

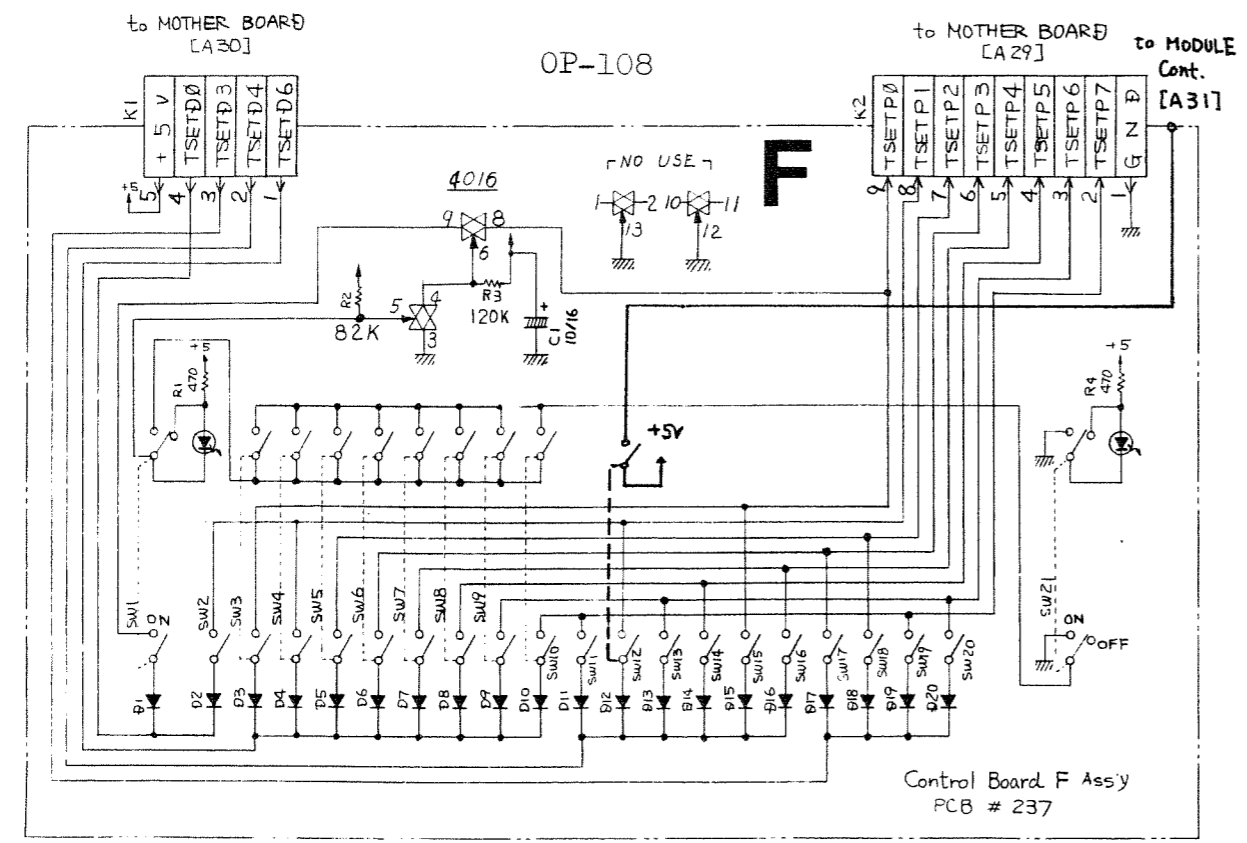
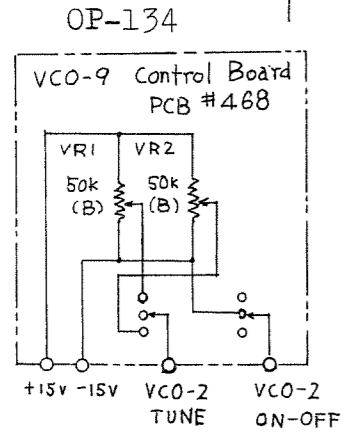
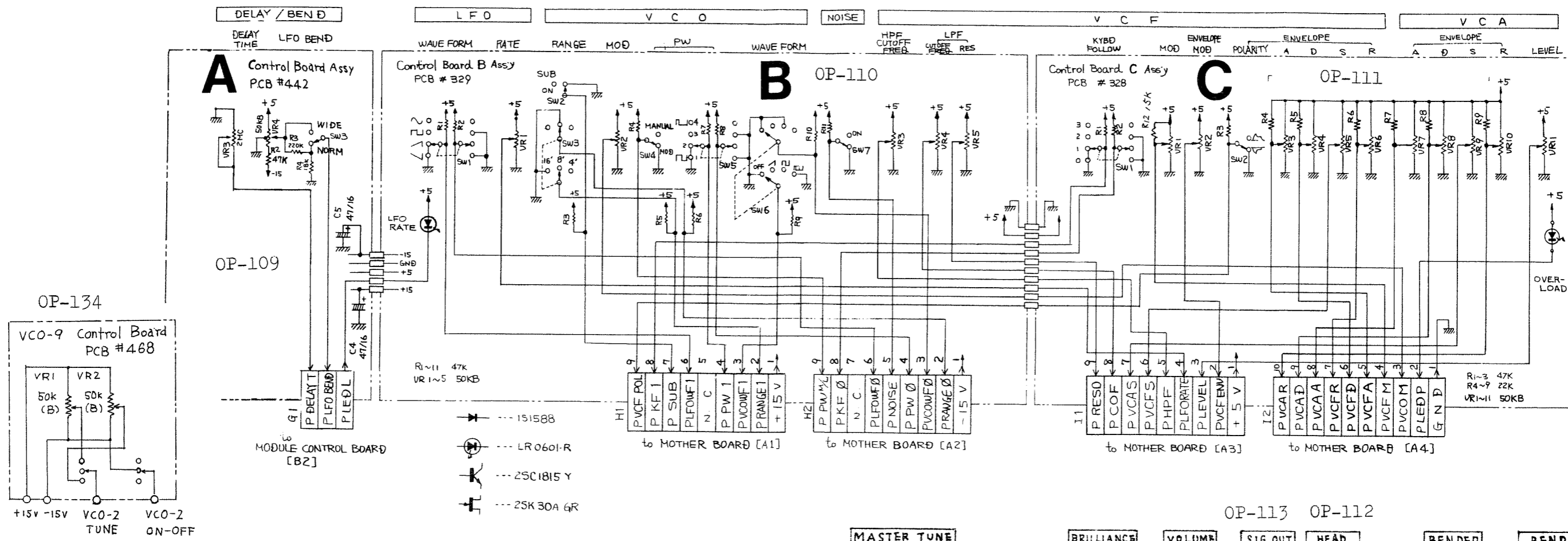

- | | | | | | | | | | | | | | | | | | | | | | |
|-------|--------|---|---|---|---|---|---|---|---|------|--------|-------|-------|-------|-------|-----------|-----|---------|-------|-----------|----------------|
| WRITE | MANUAL | 1 | 2 | 3 | 4 | 5 | 6 | 7 | 8 | BASS | STRING | FUNKY | CLAVI | PIANO | VOICE | TRX PHONE | SAX | TRUMPET | SYNTH | THE FORCE | MEMORY PROTECT |
|-------|--------|---|---|---|---|---|---|---|---|------|--------|-------|-------|-------|-------|-----------|-----|---------|-------|-----------|----------------|

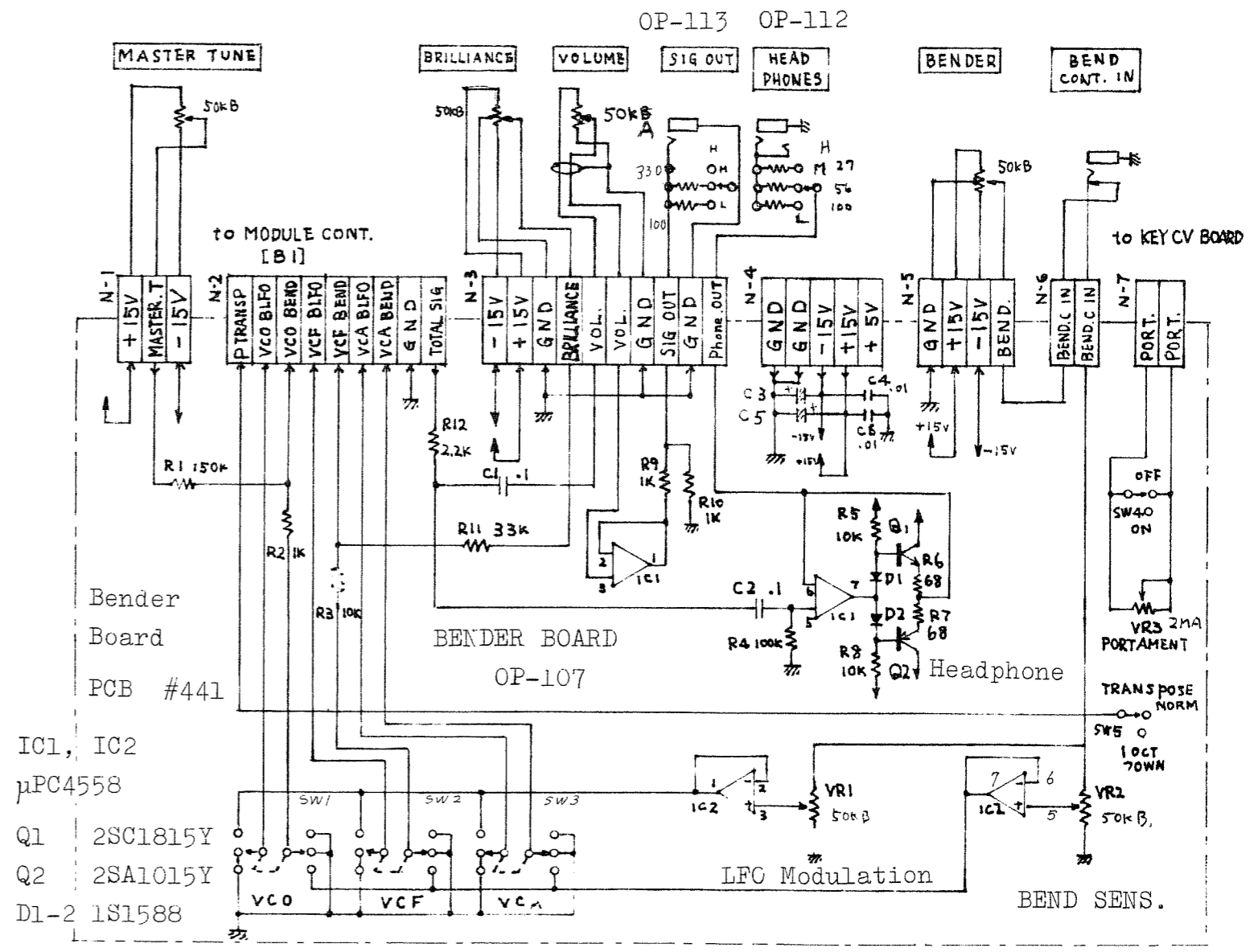

- IC1, IC2
 μPC4558
 Q1 2SC1815Y
 Q2 2SA1015Y
 D1-2 1S1588

VCO-9A (152-009A)
(PCB 052-439A)

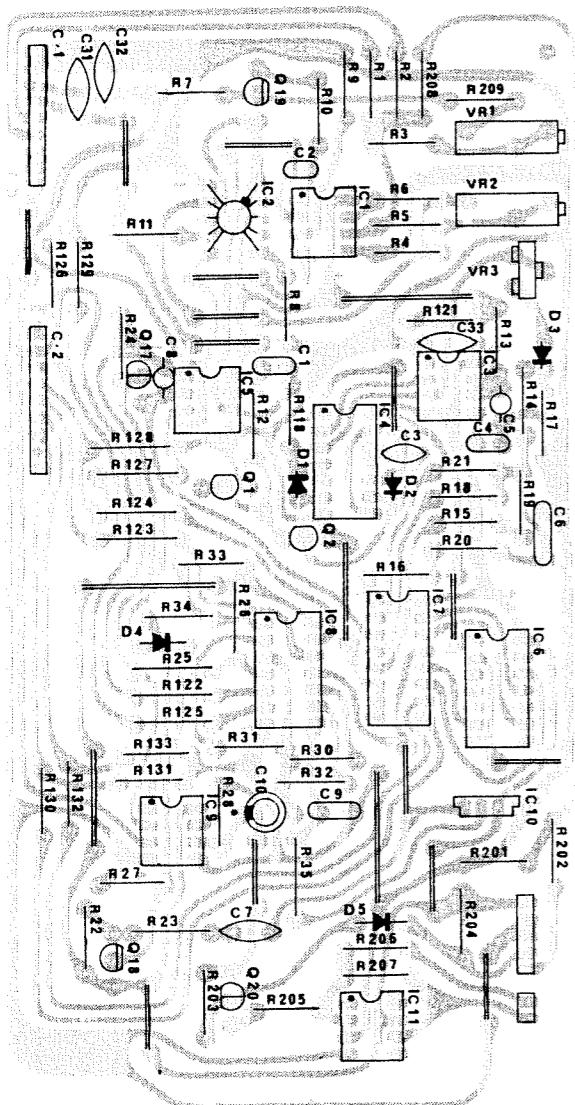

ROland
A984-830

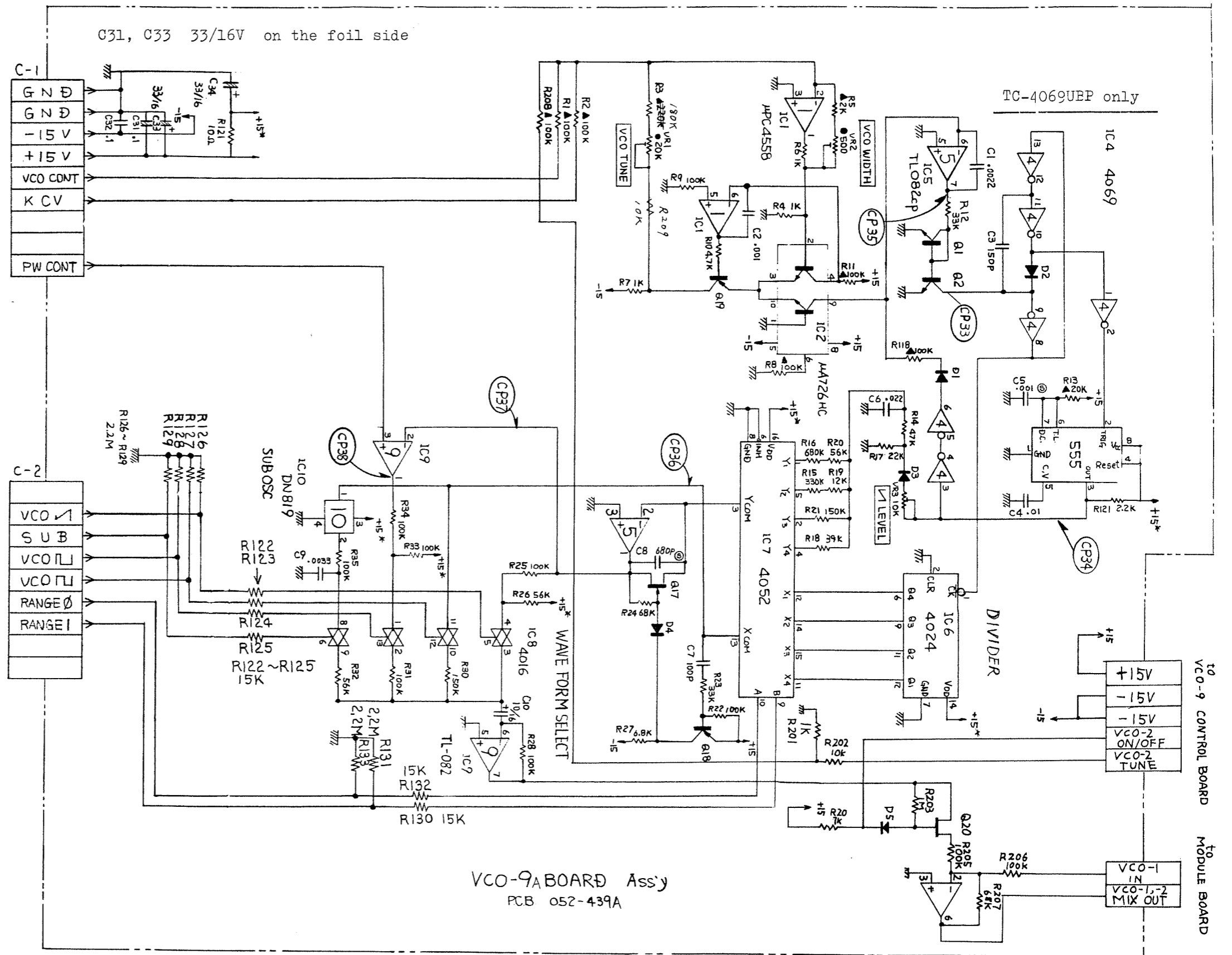

- ▲ --- 1S1588
- ⊗ --- Polystyrene Film Capacitor (C5, C8)
- ⊕ --- 2SA1015 Y
- ▲ --- CRB 1/4FX MFR
- ⊕ --- 2SC1815 Y
- --- MF VR
- ⊕ --- 2SK30A GR

KCV BOARD

CV-3B (152-003B) (PCB 052-440B)
S/N 850730 and higher

CV-3A (152-003A) (PCB 052-440A)
S/N up to 850729

- * -- 1S1555
- * -- 2SA1015
- * -- 2SC1815

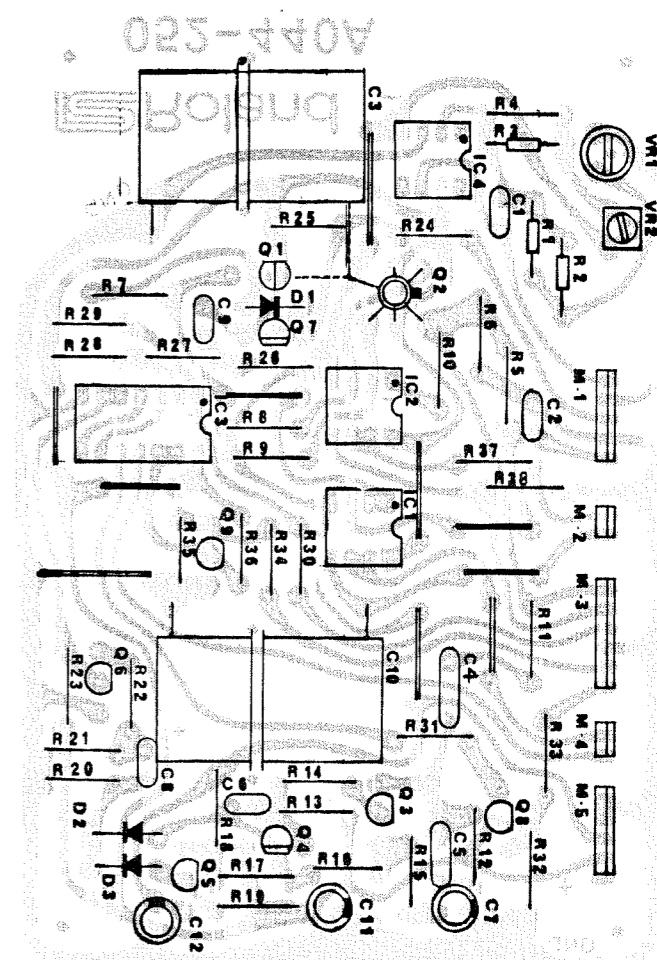
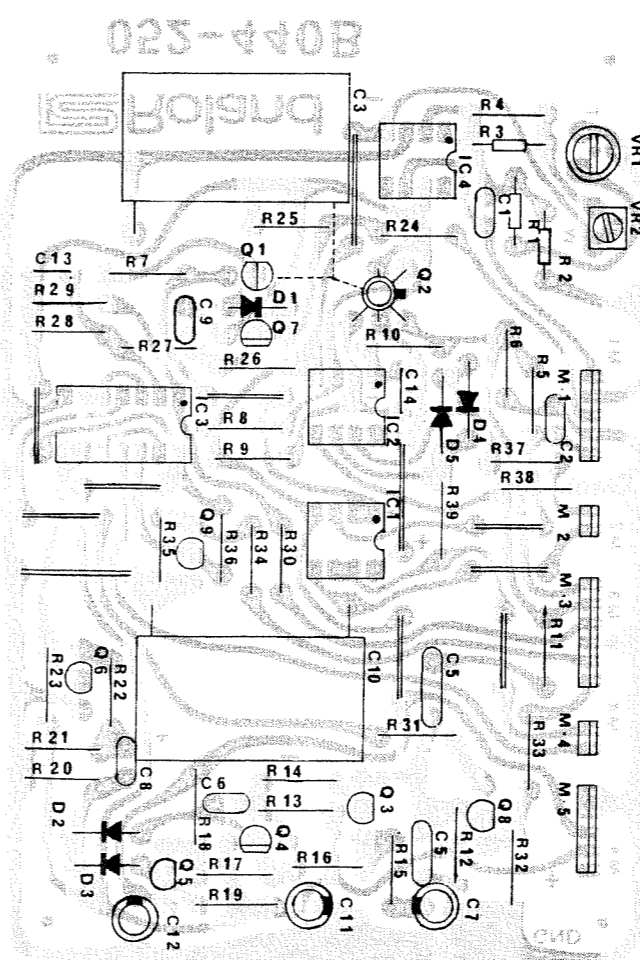
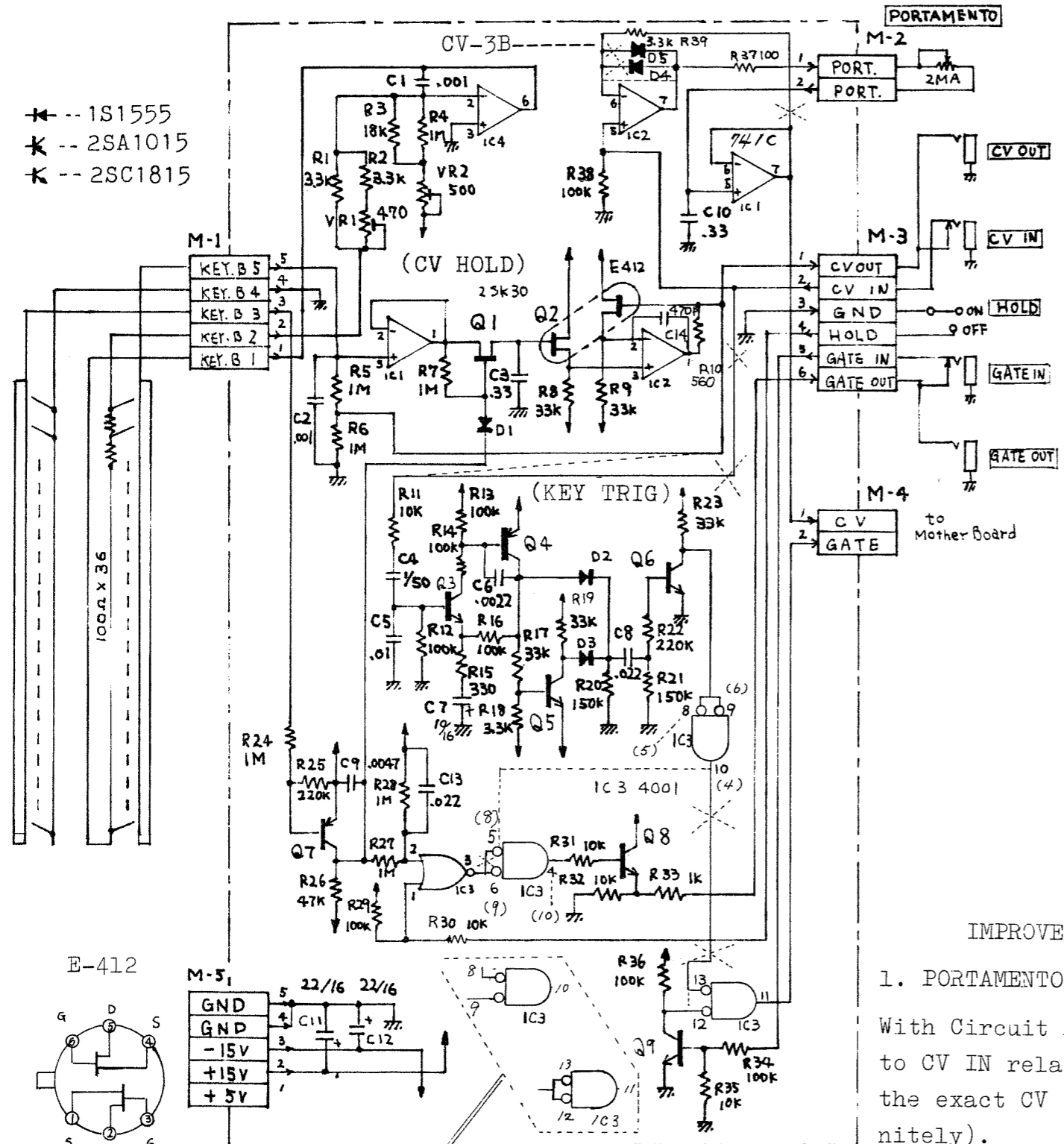

IMPROVEMENTS on CV-3

1. PORTAMENTO (with serial number 850370 -- CV-3B)
With Circuit A in the figure right, C charges close to CV IN relatively fast, but will not charge up to the exact CV IN for a while (theoretically, indefinitely).

Circuit B
One of the diodes keeps IC2 output 0.6V higher (in the case figure immediately right) or lower than CV IN and C10 charging (discharging) rate is speeded up along curve B. Once voltage across C10 reaches the CV IN, feedback resistor 3.3K will cause the circuit maintain the CV.

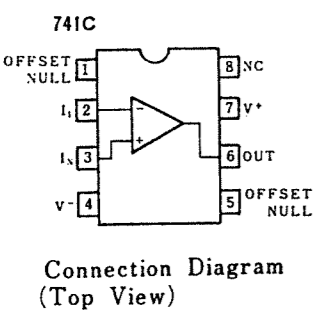
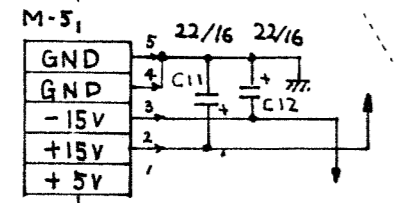
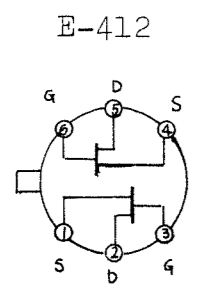
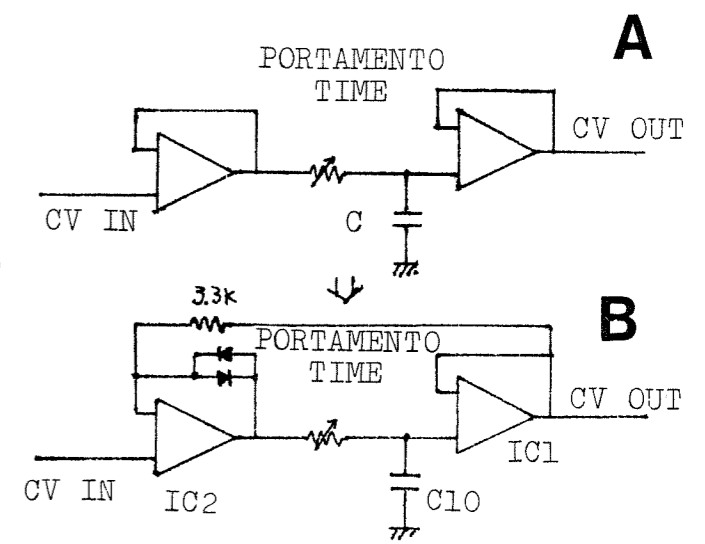
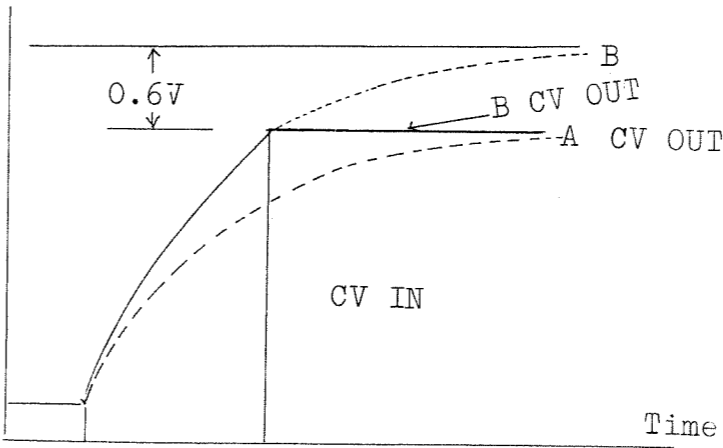

Dotted lines and paranthesises with numbers show original CV-3A circuit arrange.

Connection Diagram (Top View)

**MODULE CONTROL OP-106C (149-106C)
(PCB 052-235C)**

Moving the A, D or R sliders from bottom to top will increase the frequency by approximately 1000.

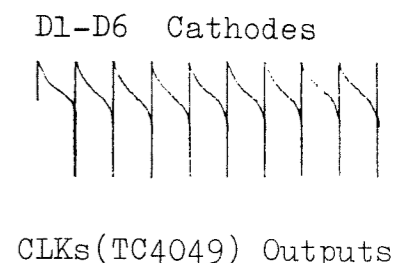

Improvements on CV-3 cont'd
2. Shifting TRIG. GEN. - CV-3A only
This relieves the following:
When keys on MRS-2 are played in legato with the CV and GATE IN/OUT jacks being connected to a CSQ-100, tones corresponding to the subsequent keys can fade away along with the first key's envelope decay (a remarkable example is Preset PIANO).
This is because Gate-retrigger pulse, being blocked with CSQ-100 circuits, does not exist at GATE IN, failing to re-set envelope generator for individual keying that follows to the first keying in sequence.
After modification, MRS-2 has no detrimental effects on sequencers other than CSQ-100.

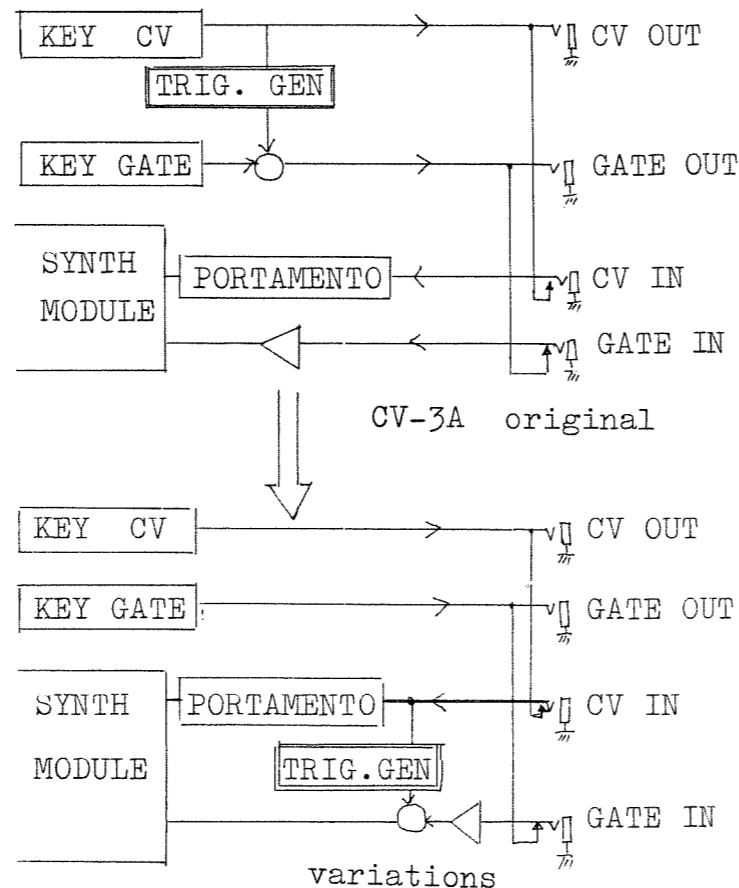

The modification was conducted on MRS-2 with serial number 840630; besides, products bearing the following numbers have been modified before shipment.

- 830568-830599 830600-830617
- 810260-810279 830528-830529
- 830533-830534 830540-830545
- 830547-830548 830556-830557
- 830552.830554 830619.830621

modification on PCB

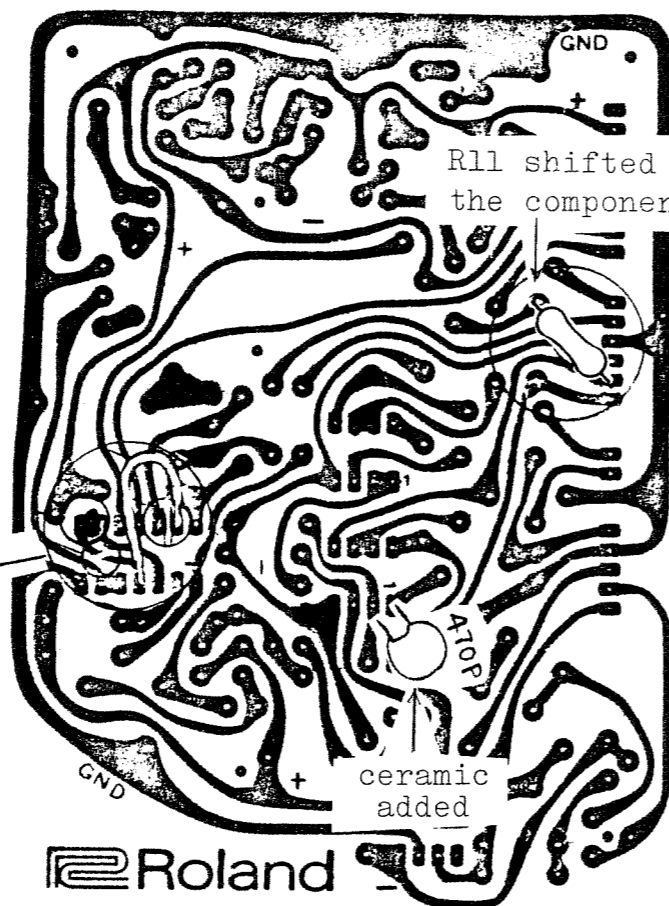

R11 shifted from the component side

Roland
052-440A

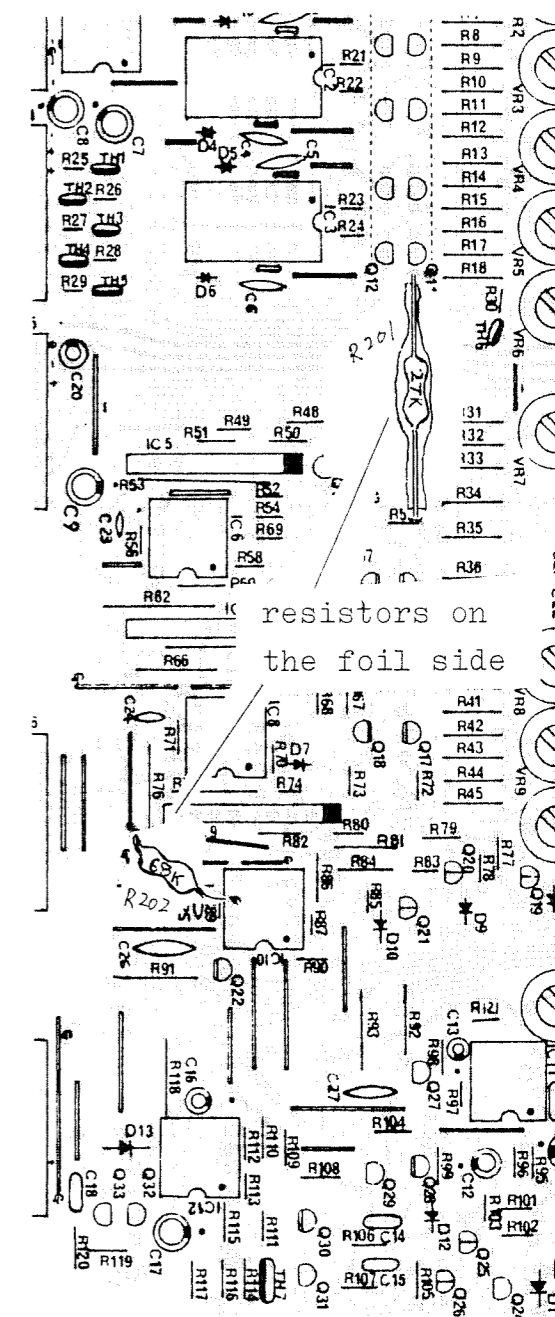
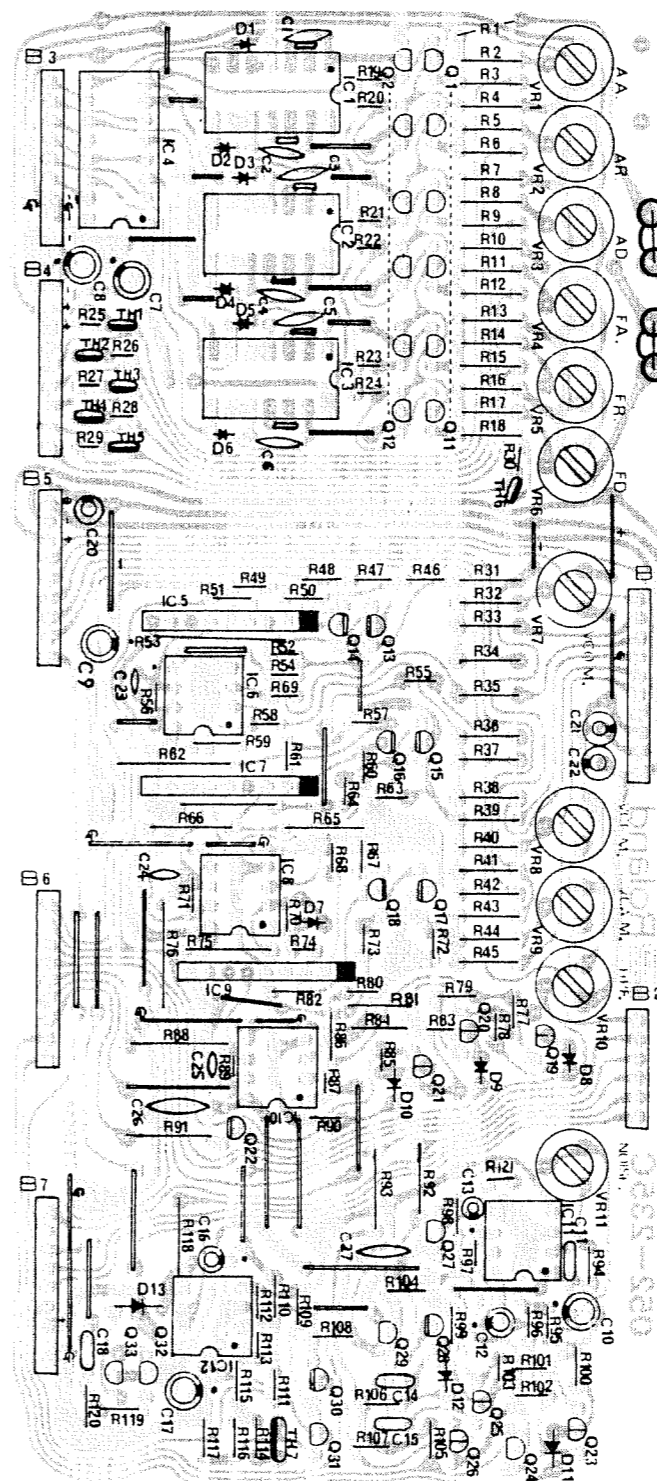

resistors on the foil side

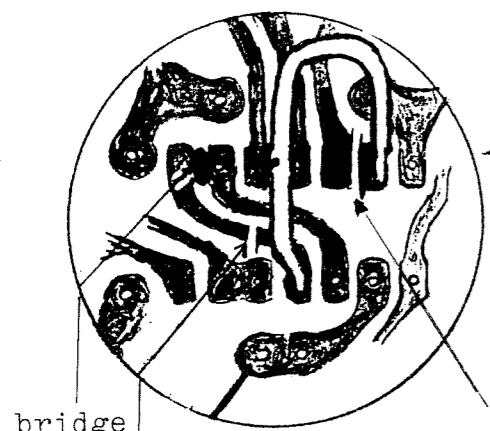

bridge

foil scraped off

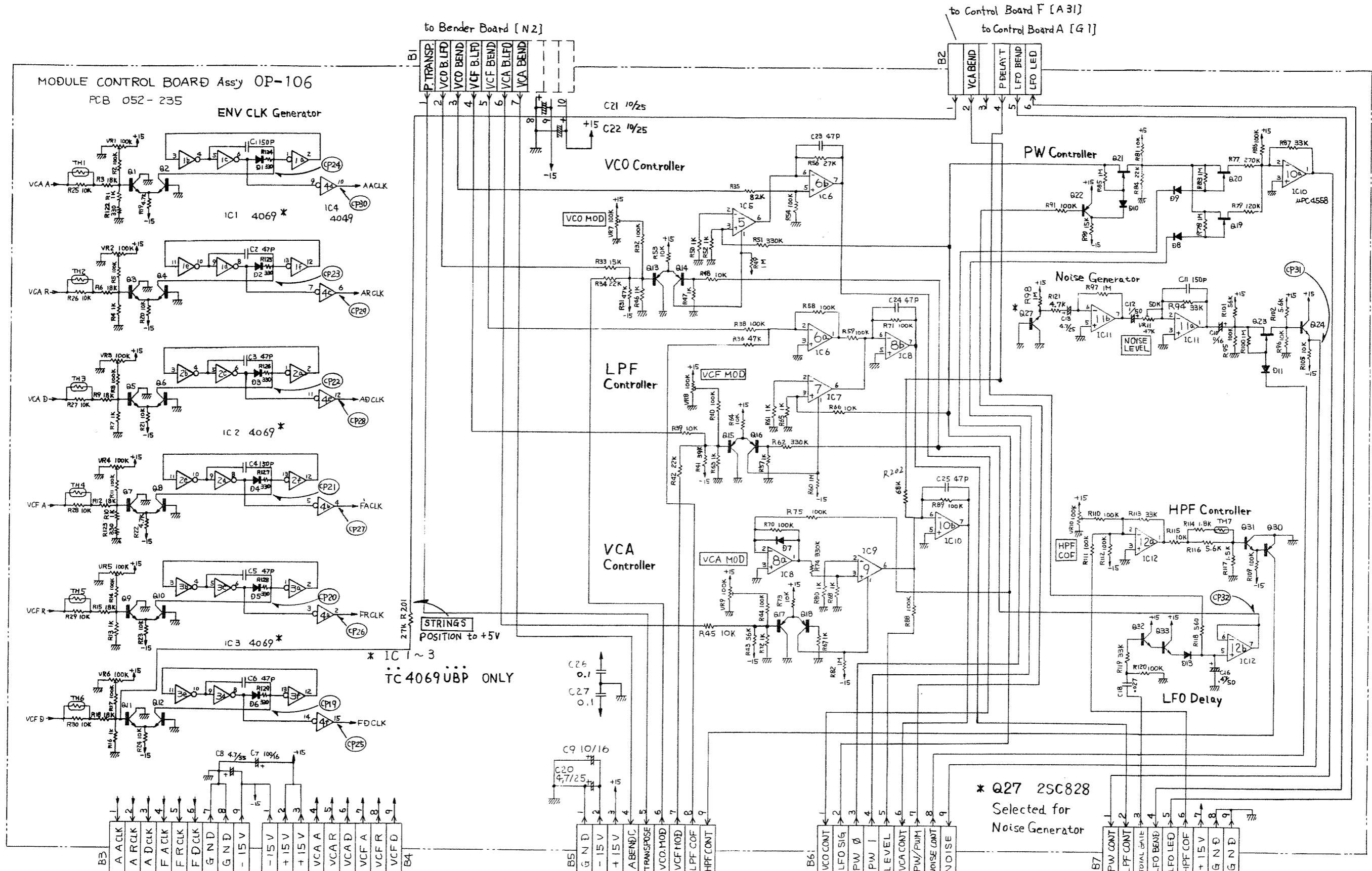

to MOTHER BOARD A21

A22

--- 25C1815 Y
 --- 25C 828
 --- 25K 30A 6R

to MOTHER BOARD A23

B5

A24

to MOTHER BOARD A25

A25

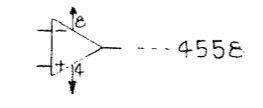
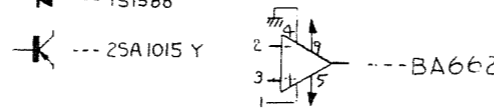
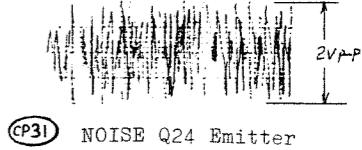
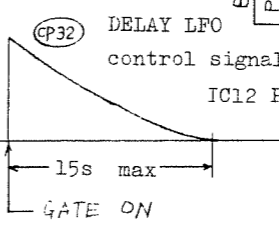

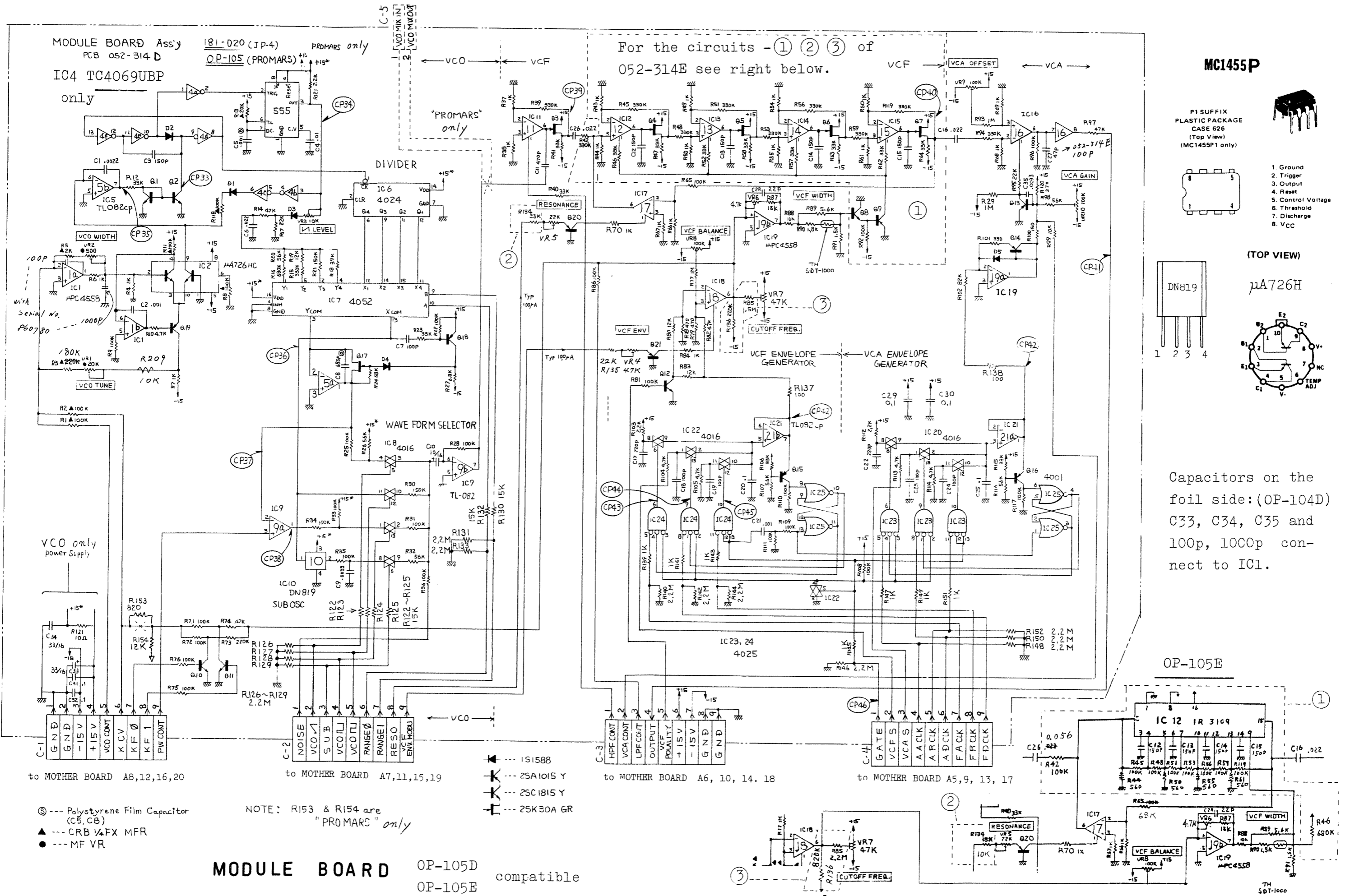

MODULE BOARD

BA662

Besides BA662 -A and -B, there are factory selected marked with various colors. Although they are interchangeable, however, because of electrical characteristic differences, use only in complete set of the same color.

For non-selected: BA662A is a good replacement for BA662B while BA662B cannot replace for BA662A.

OP-105D (149-105D) (PCB 052-314D)

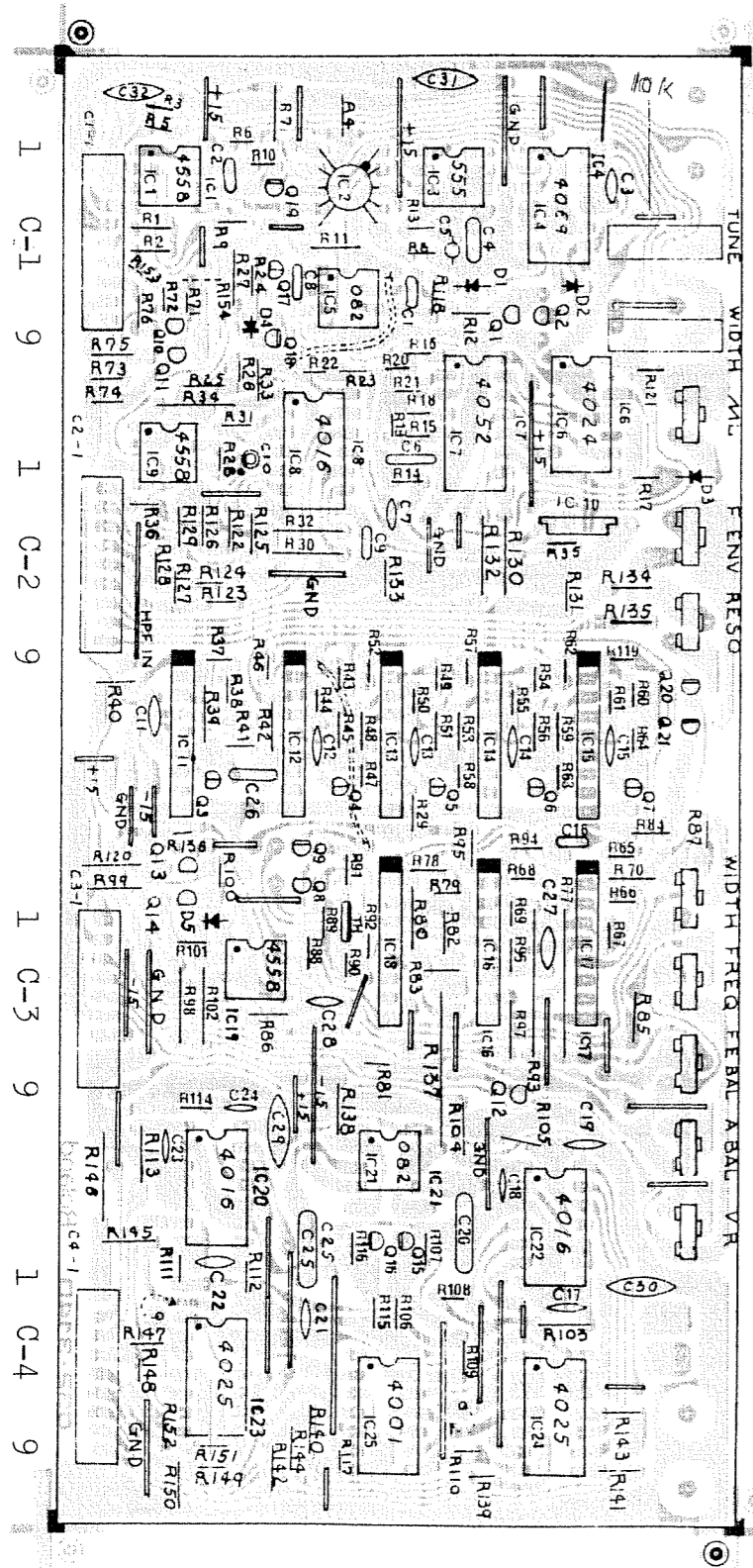

OP-105E (149-105E) (PCB 052-314E)

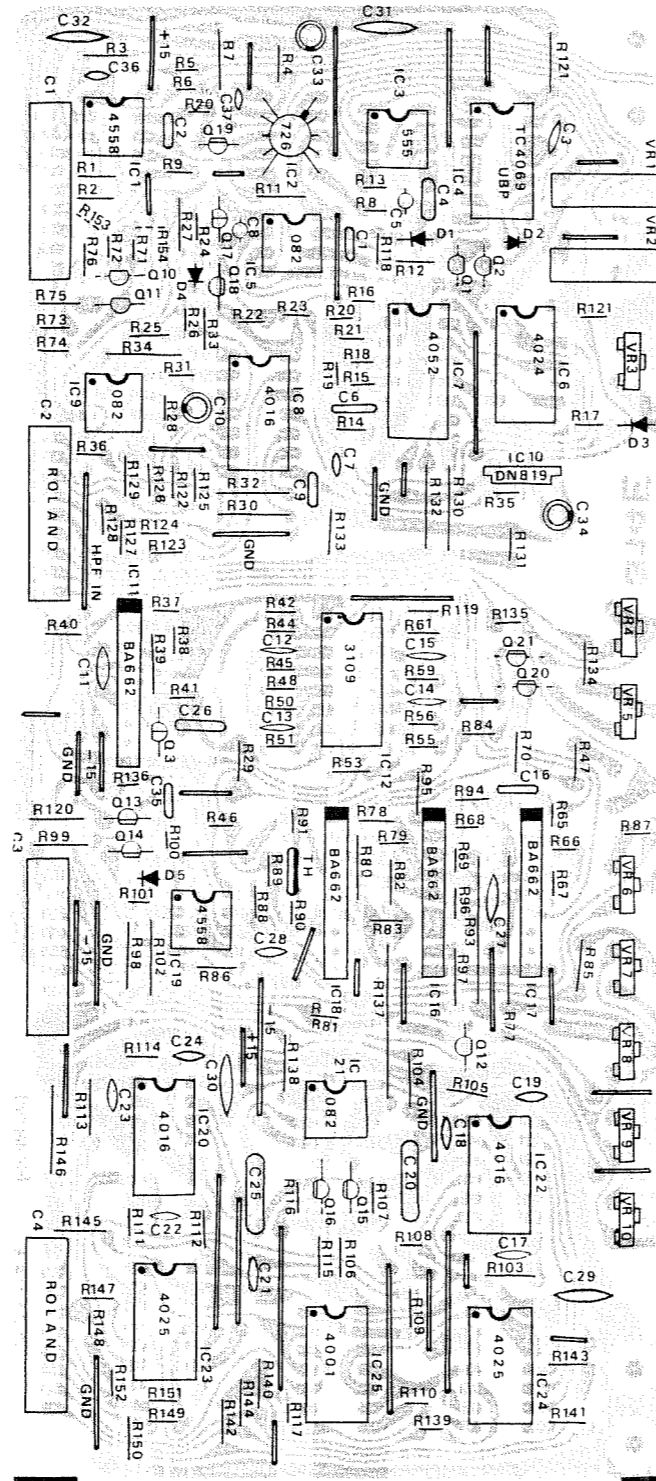

POWER SUPPLY BOARD

PS-52F(146-052F) 100V

PS-53F(146-053F) 117V

PS-54F(146-054F) 220/240V

(PCB 052-327F)

FUSES

AC	F1-F3	F4
100/117V	SGA0002(2A) (008-028)	SGA0001(1A) (008-026)
220/240V	CEE T2A (008-070)	CEE T500mA (008-063)

- Q1, Q2 2SA1015-Y
- Q3 2SB596-Y or 2SB434-0
- Q4 2SD880-GR or 2SD234-Y

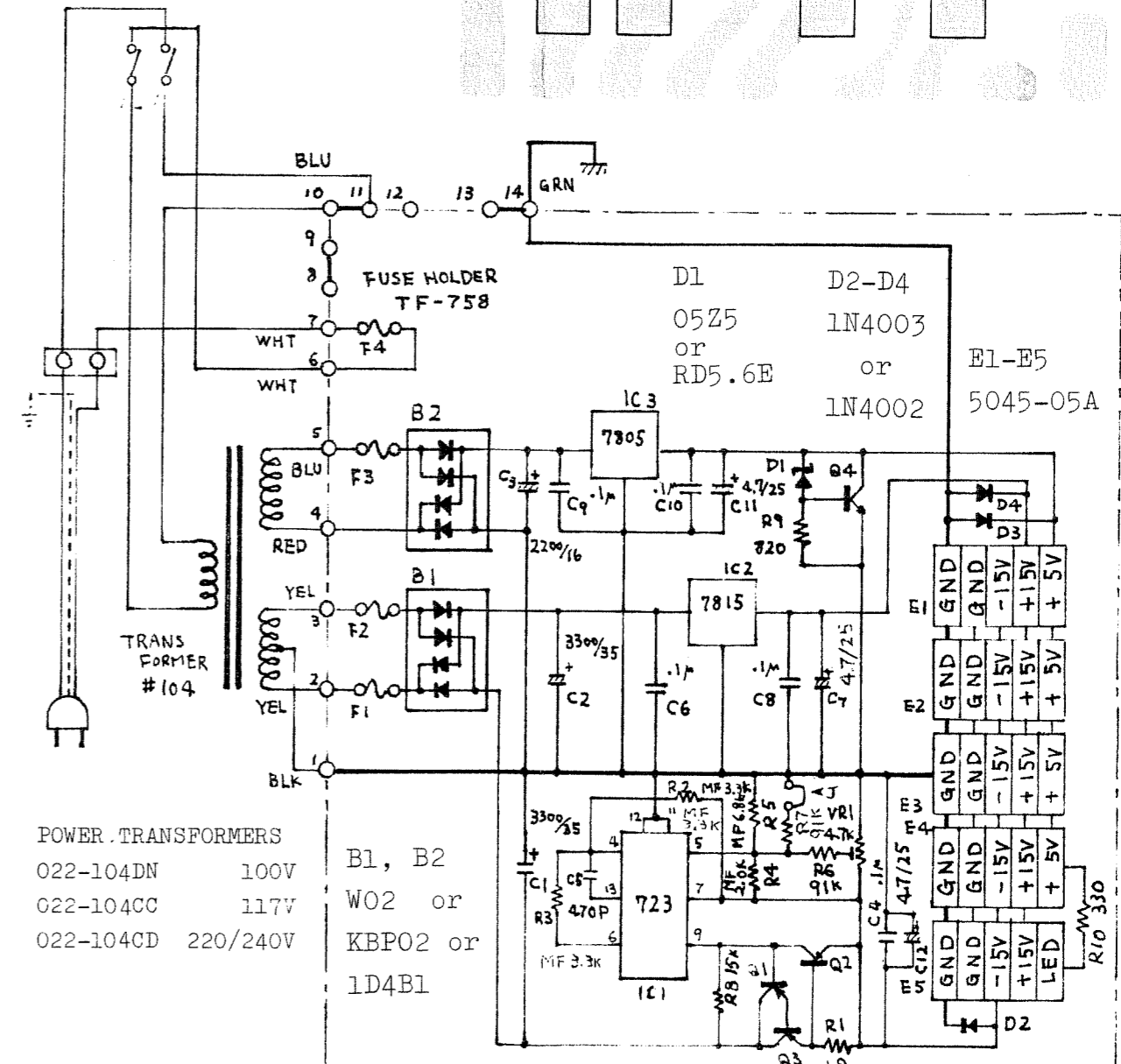
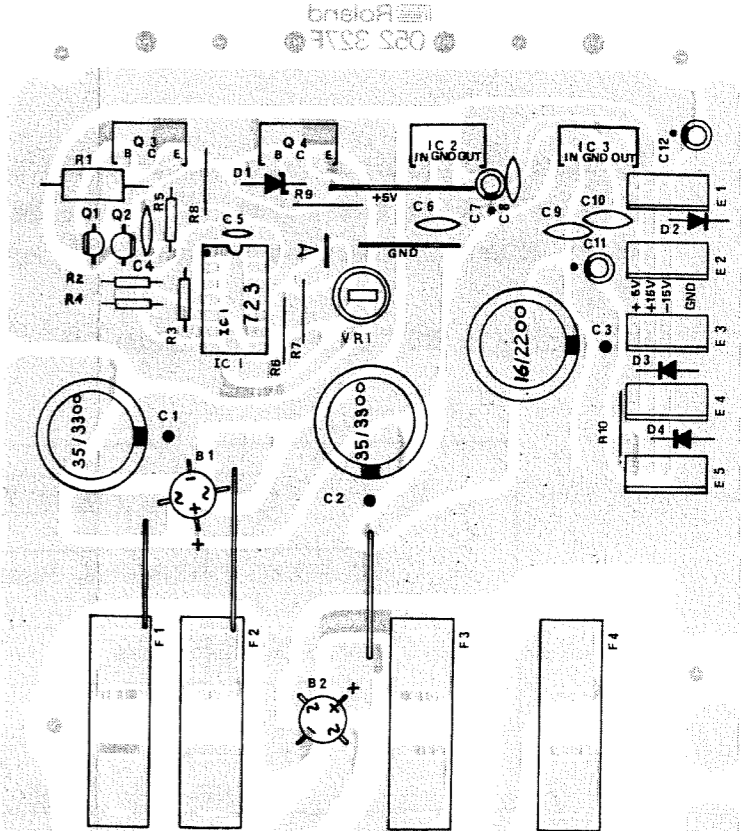

- POWER TRANSFORMERS
- 022-104DN 100V
 - 022-104CC 117V
 - 022-104CD 220/240V

- B1, B2
- W02 or
- KBPO2 or
- 1D4B1

ADJUSTMENT

Because certain circuits of PROMARS are voltage controlled, Power Supply Board, PS-52/53/54 is the first to be checked and adjusted. Also repairing or replacing PS-** Board forces readjustment of some associated PCBs, CV-3, OP-104, VCO-9 and OP-105.

Replacing a PCB other than Power Supply Board involves readjustment of its own.

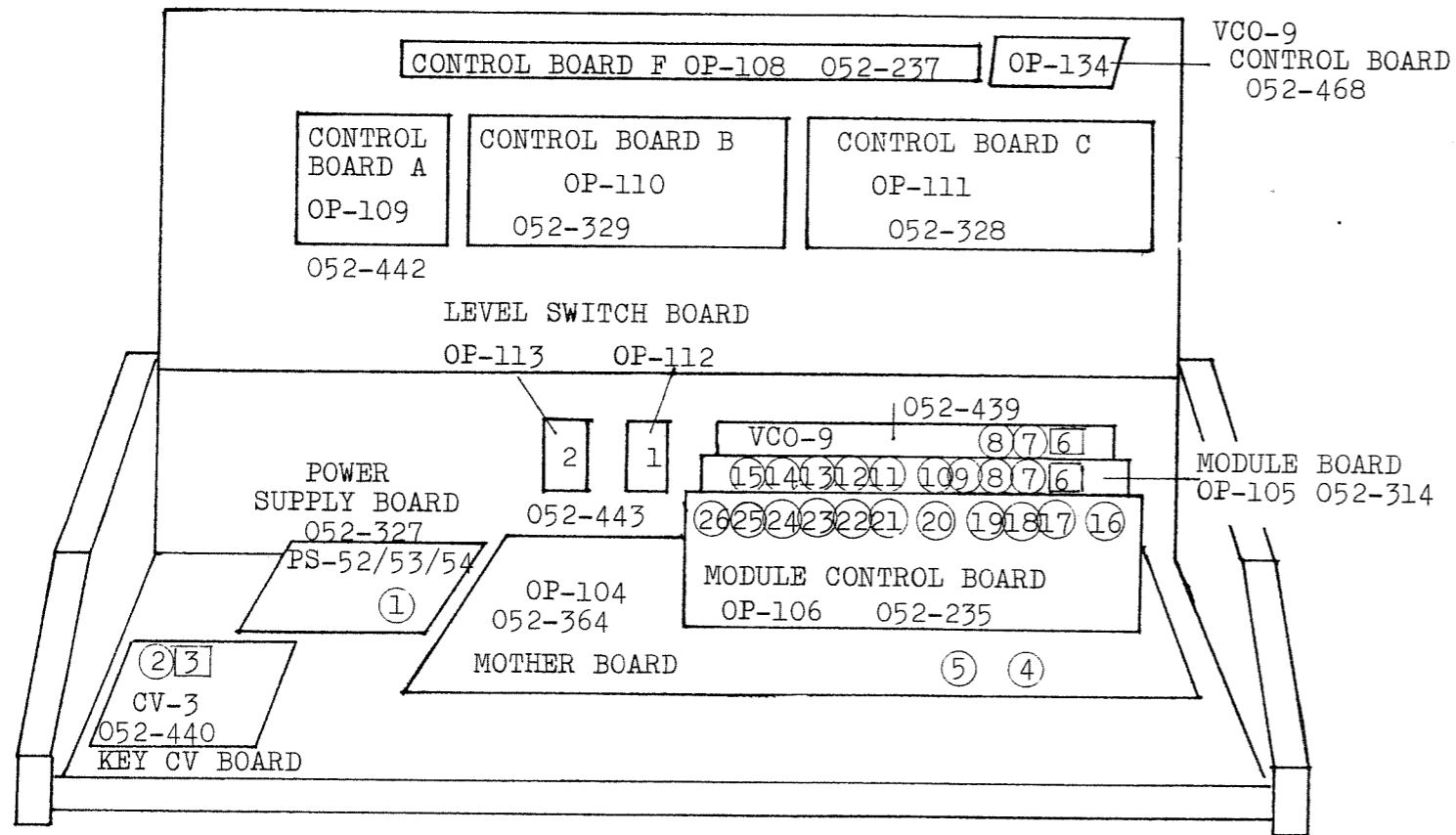

Numbers, ①, ②, ③, etc. in above figure show adjusting trimmer potentiometers and are independent of designations in individual circuit diagram.

In this adjustment, trimmer pots are abbreviated as "P-xx".

1. DC VOLTAGE (-15 Volt)

Allow at least five minutes for warmup.

1. Connect a digital voltmeter to TP-1.
2. Adjust P-1 for $-15.0 \pm 10\text{mV}$.
3. Check other voltages, they must be

$+5.0 \pm 250\text{mV}$ and $+15.0 \pm 750\text{mV}$.

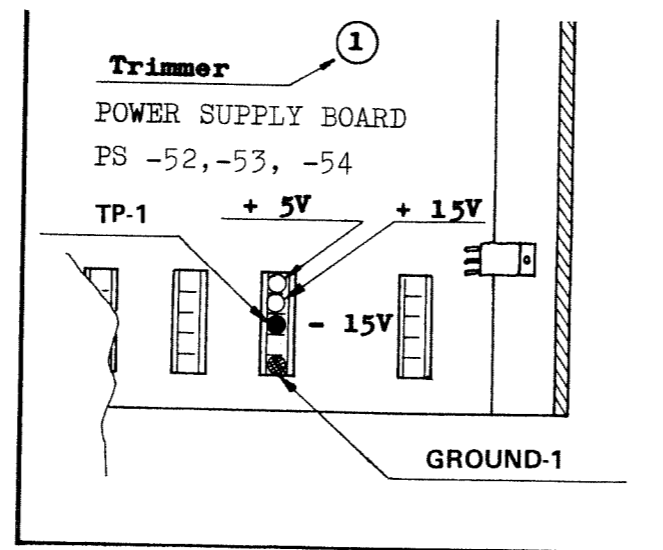

2. KEY CV and WIDTH

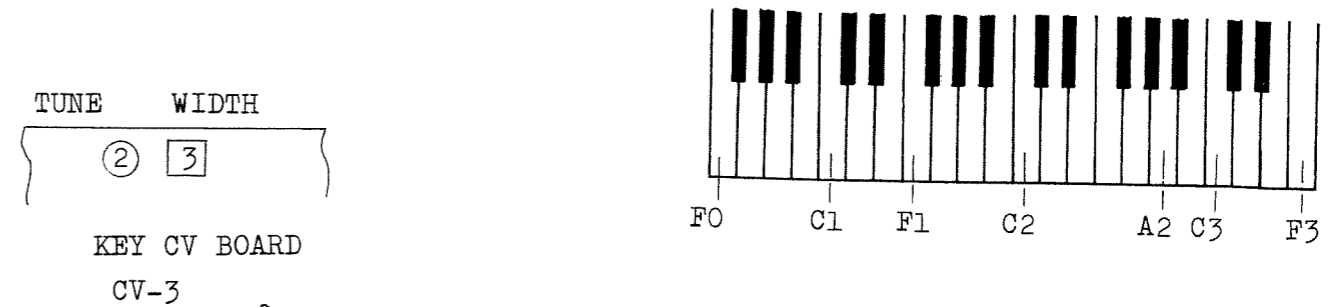

Connect digital voltmeter to the hot terminal on CV OUTPUT jack.

1. While depressing C1 and C2 keys alternately, adjust P-3 so that $C2V = C1V + 1.00V \pm 3\text{mV}$.
2. Hold down C1 key and adjust P-2 to provide $2.00 \pm 2\text{mV}$.
3. Check octave keys for errors:
 $C2 = 3.00 \pm 3\text{mV}$ $C3 = 4.00 \pm 3\text{mV}$

3. LFO WAVEFORM

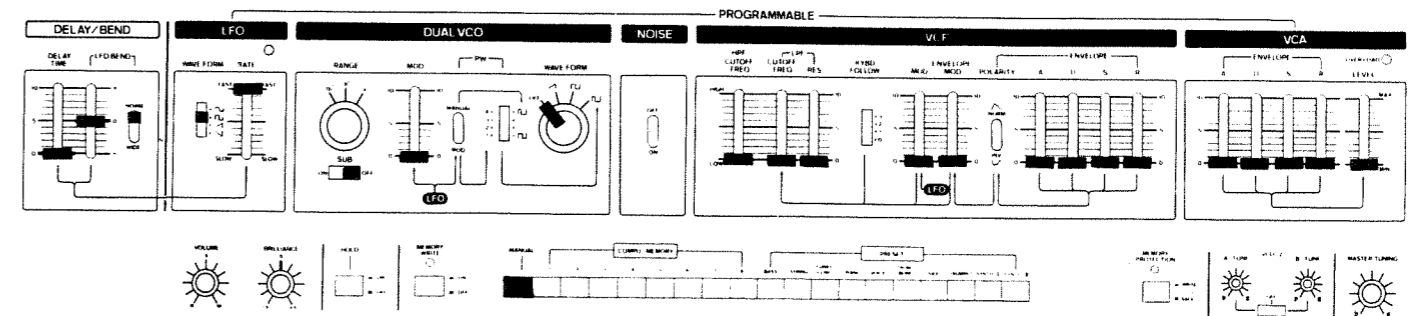

Connect oscilloscope to TP-4 on Mother Board OP-104 (see next page).

1. Adjust P-4 for slope straightness.

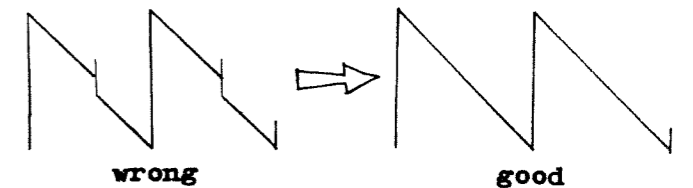

4. LFO RATE

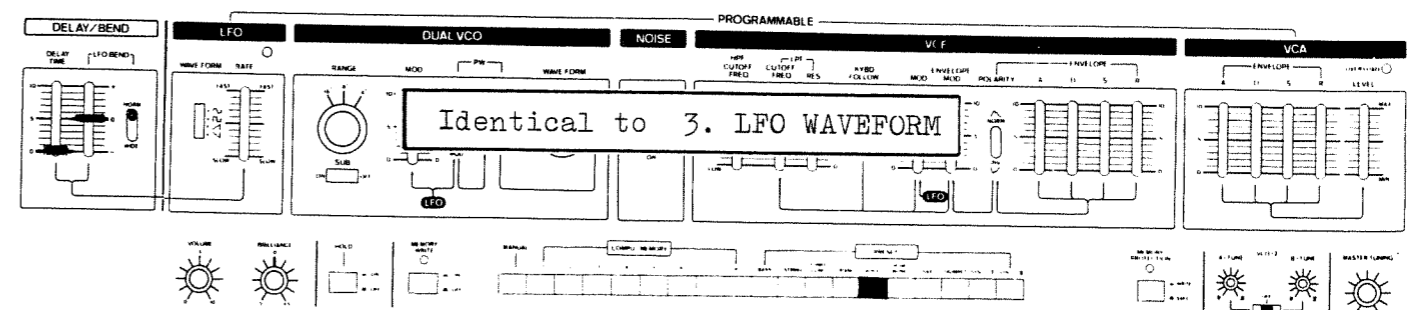

Connect scope to TP-5 on OP-104.

1. Set P-5 for 5Hz.

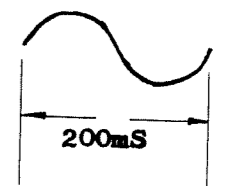

5. VCO FREQUENCY and WIDTH

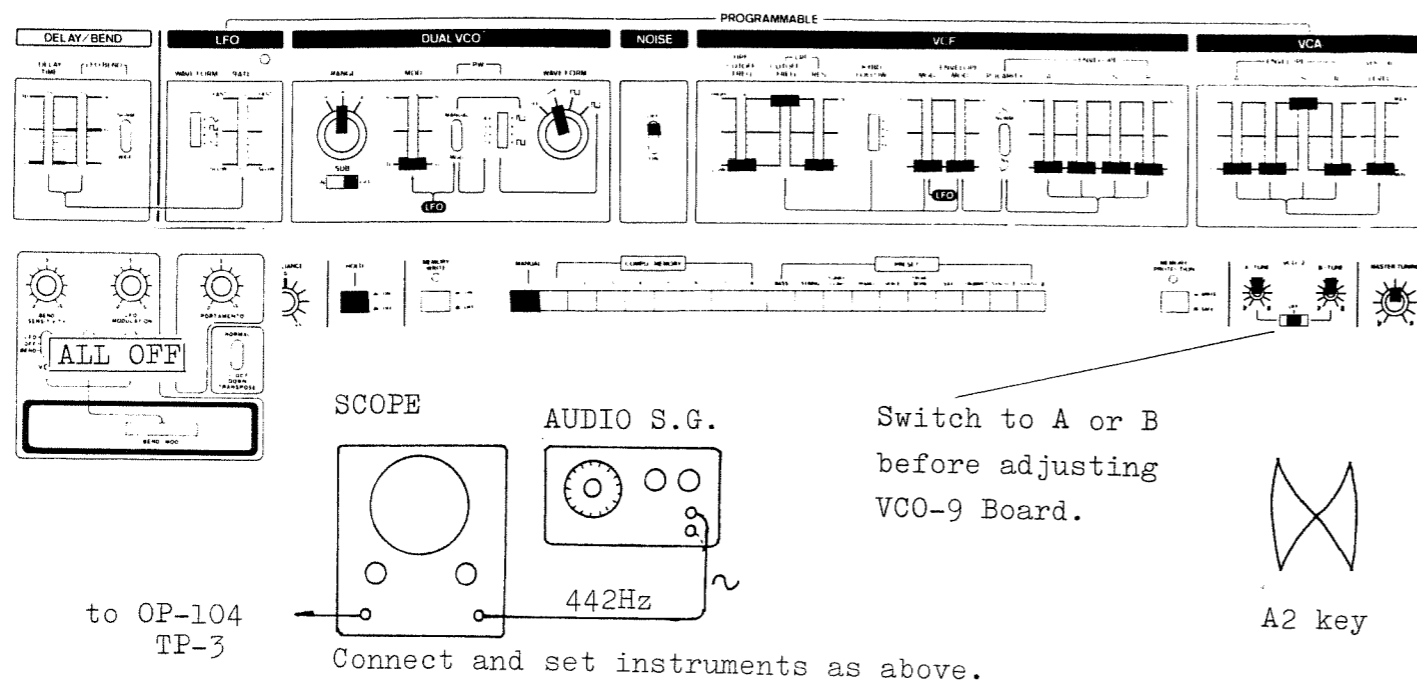

MODULE BOARD OP-105

1. While depressing A2 key, Adjust P-7 for 1:2 Lissajous figure.
2. While depressing A0 key, adjust P-6 for 2:1 Lissajous figure.

VCO-9

To disconnect VCO-1 signal path:

Pull the housing off the PCB.

Reverse it and plug in the right pin only.

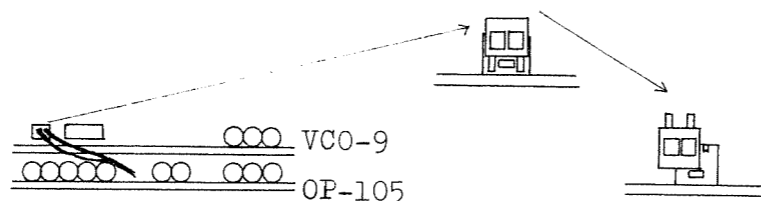

Set VCO-2 TUNE switch to A-TUNE or B-TUNE.

Adjust P-6 and P-7 on VCO-9 Board following the steps in OP-105.

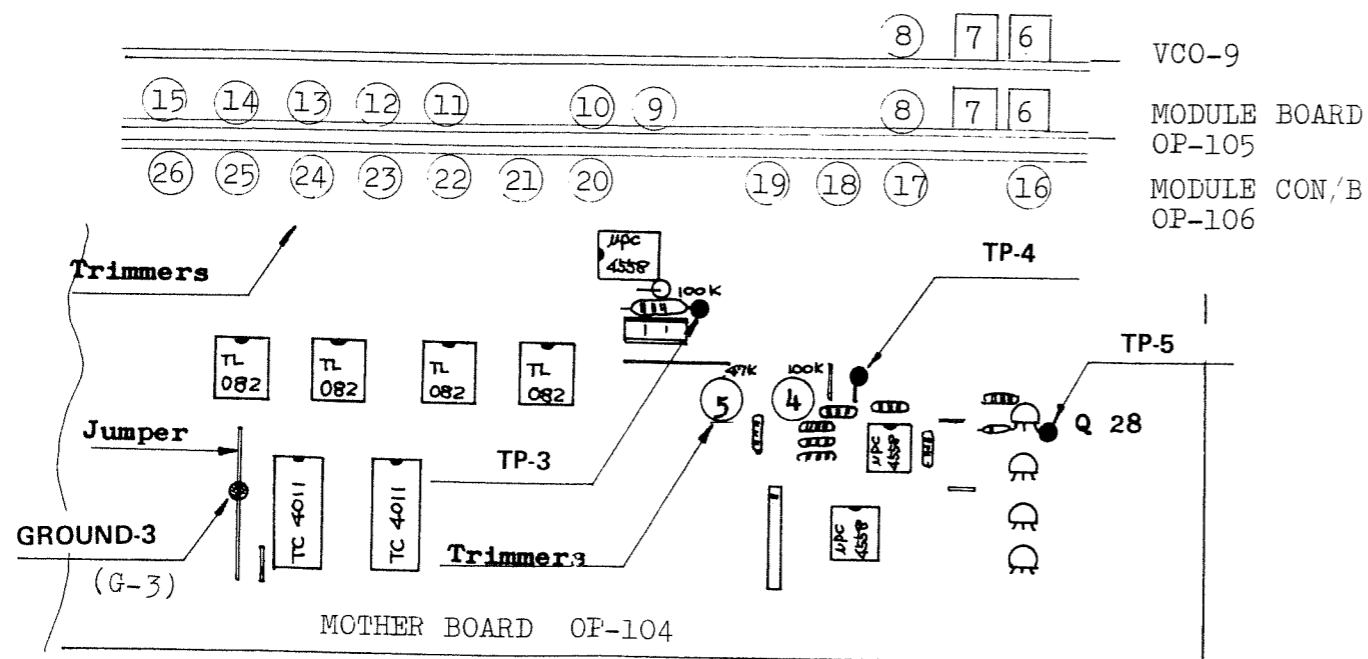

6. VCO WAVEFORM (Pulse width 50%)

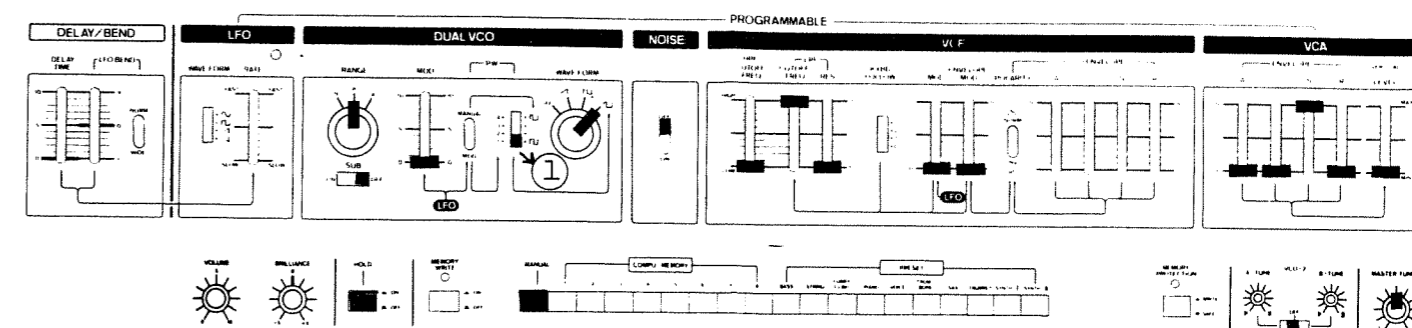

Test Point - TP-3 on OP-104

- OP-105 Set P-8's respectively for 50% duty ratio with C1 key holding down.

7. VCF FREQUENCY and WIDTH

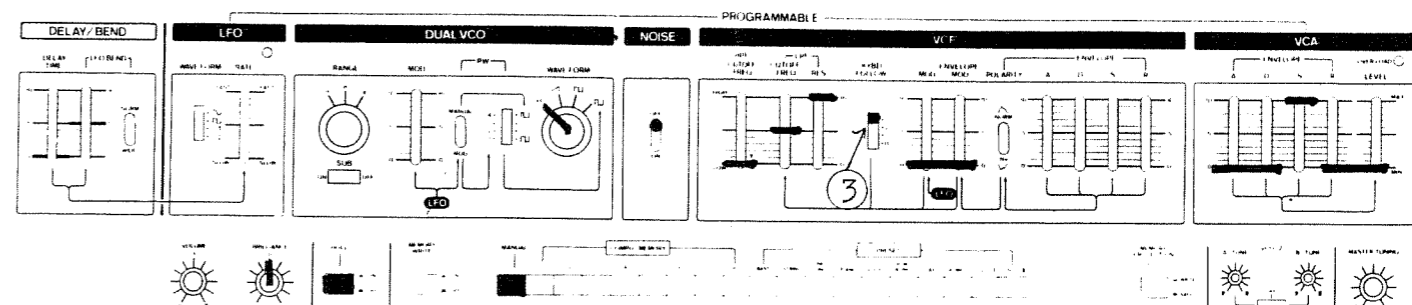

NOTE: Due to the digital control characteristics of this VCF, if CUTOFF FREQ knob is moved steadily and slowly, the resonating VCF will produce frequencies in a series of steps. If CUTOFF FREQ is set at a point exactly between two of these steps, the resulting frequency will be unstable as it jumps up and down between these two steps. The knob must be set at a point near "5" where VCF output frequency locks positively on one frequency or the other.

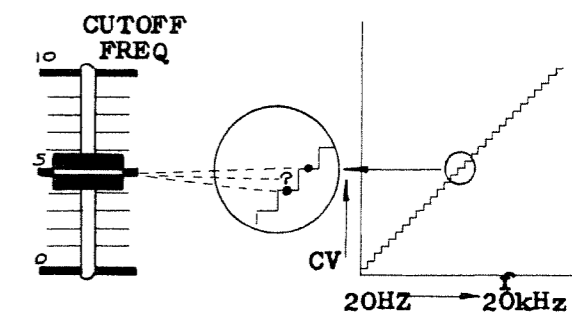

Test Point - TP-3 on OP-104

1. While depressing F1 and F2 keys alternately, adjust P-11 on OP-105 to display two figures of 2:1 period.

Reset KEY FOLLOW at "0".

2. Adjust P-12 on OP-15 for 880Hz. (by displaying Lissajous figure, etc.)
3. Check F1, F2 keys for deviations in step 1.

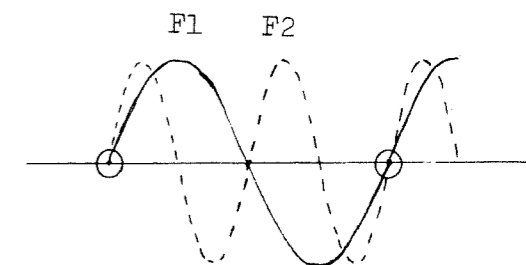

8. VCF RESONANCE

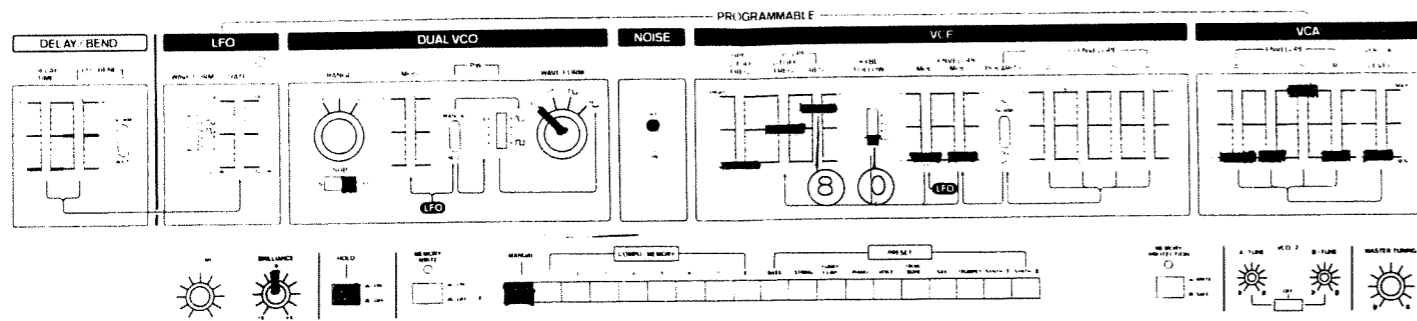

Test Point - TP-3 on OP-104

1. While depressing a key, adjust P-10 on OP-105 so that VCF just begins oscillation. Approx. 800mVpp sine with RESONANCE set at "8".

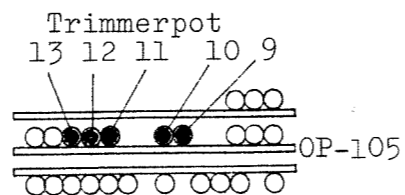

9. VCF ENVELOPE BALANCE

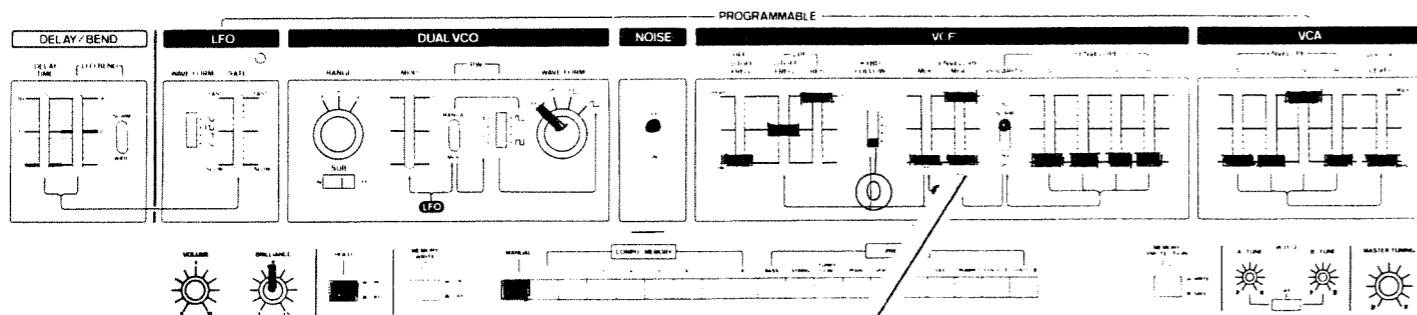

Test Point - TP-3 on OP-104

1. Adjust P-13 on OP-105 so that moving ENVELOPE MOD between "0" and "10" produces no frequency change.

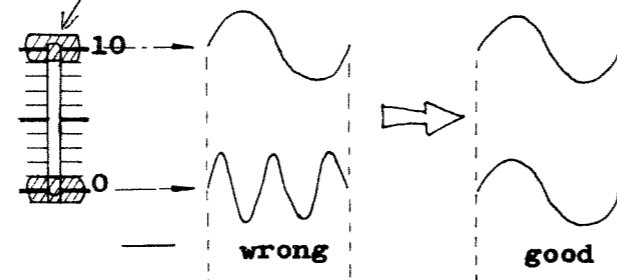

10. VCF ENVELOPE MODULATION DEPTH

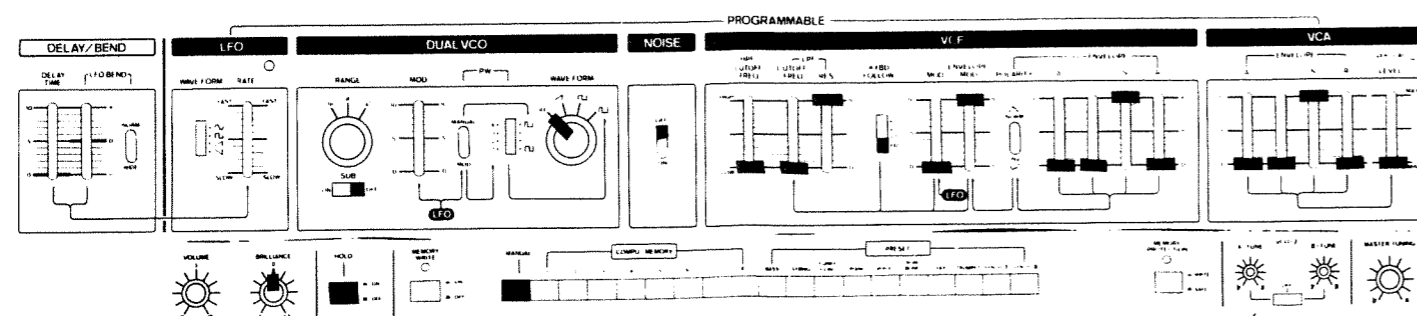

Test Point - TP-3 on OP-104

1. With one key holding down, set P-9 on OP-105 for 12K±1KHz.

11. VCA BALANCE

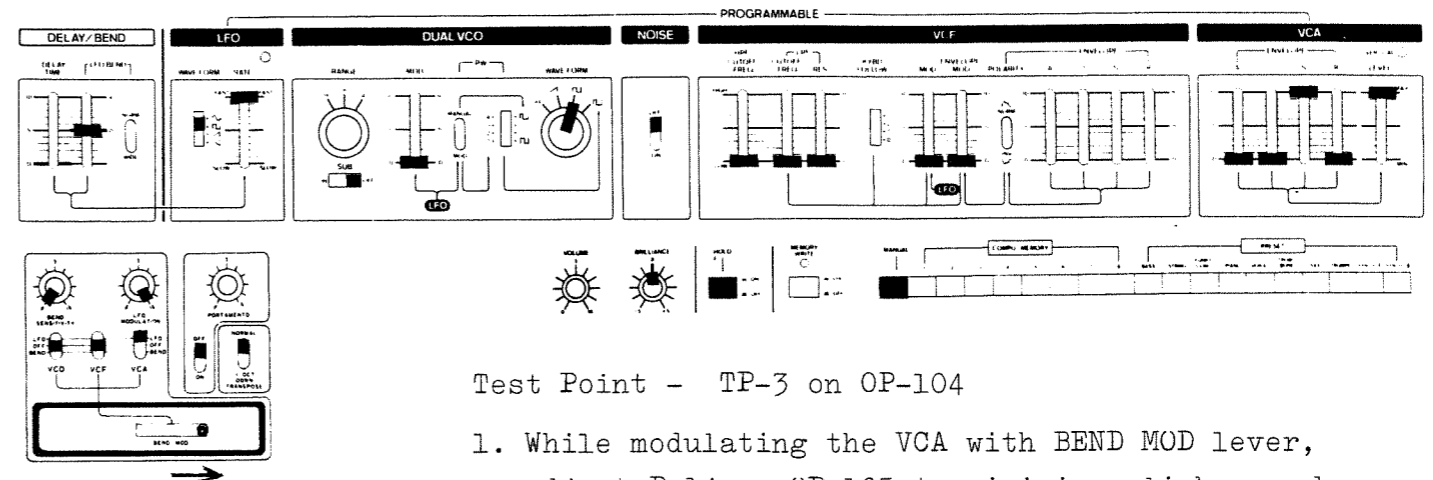

Test Point - TP-3 on OP-104

1. While modulating the VCA with BEND MOD lever, adjust P-14 on OP-105 to minimize click sound.

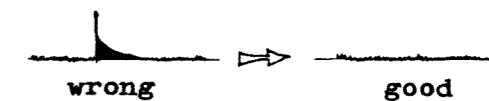

12. VCA LEVEL

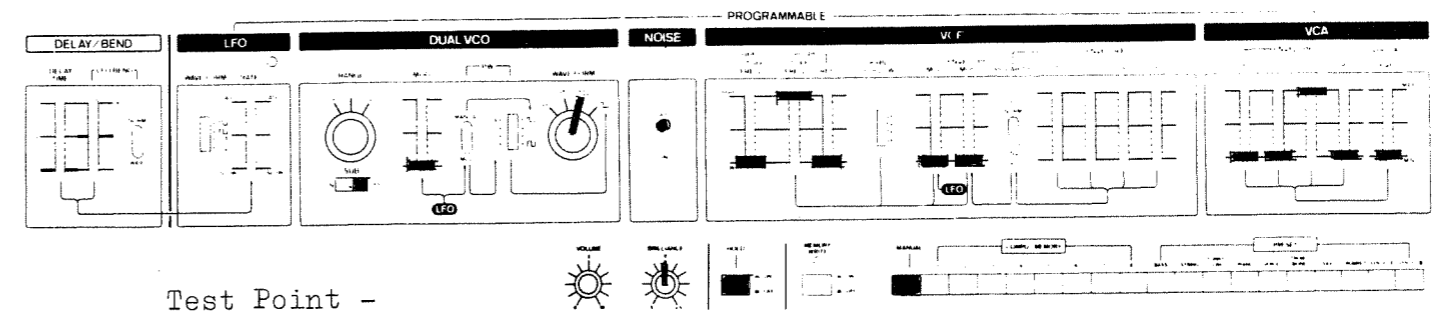

Test Point - TP-3 on OP-104

1. While depressing down C2 key adjust P-15 on OP-105 for:

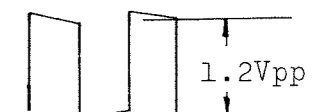

13. LFO VCO MODULATION

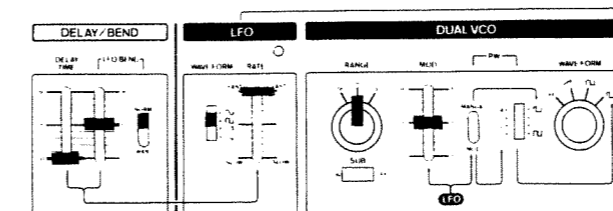

Test Point - TP-10 on OP-106

Connect scope ground to G-3 on OP-104

1. Set P-20 on OP-106 for 150mVpp ±10%.

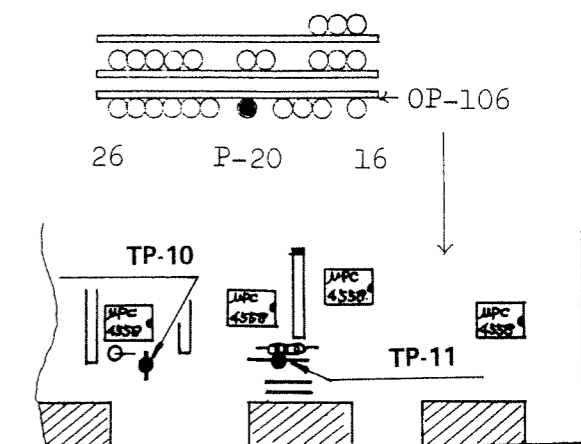
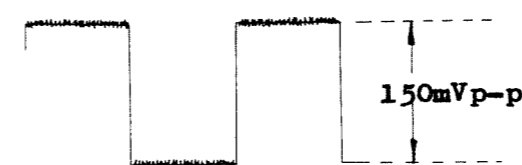

14. LFO VCF MODULATION

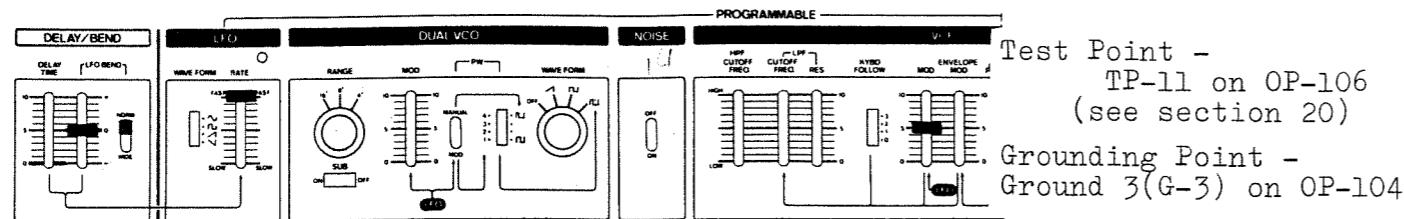

Test Point - TP-11 on OP-106
(see section 20)
Grounding Point - Ground 3(G-3) on OP-104

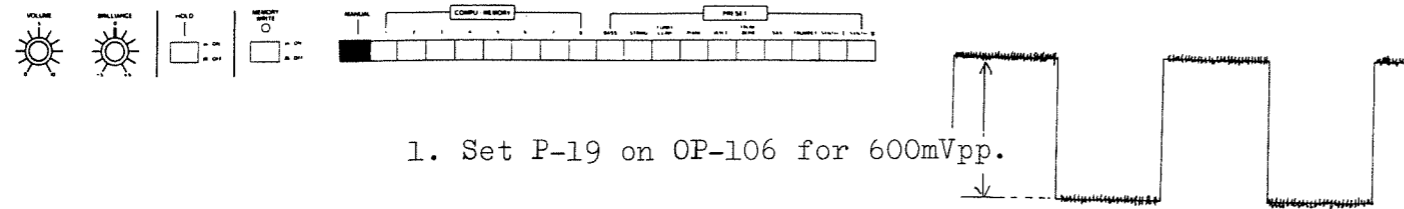

1. Set P-19 on OP-106 for 600mVpp.

15. LFO VCA MODULATION

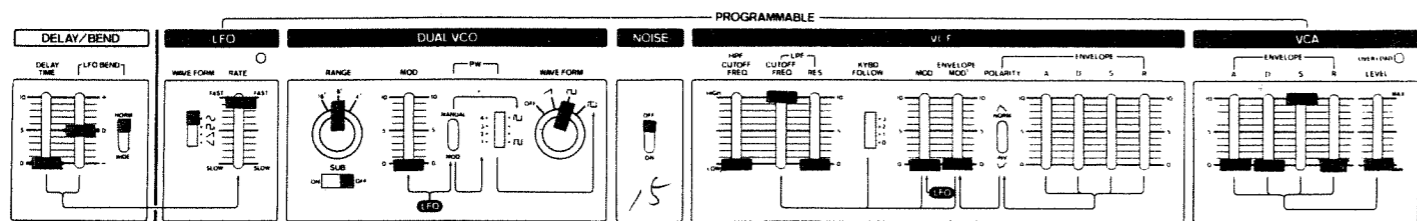

Test Point- TP-11 on OP-106. Ground Point- G-3 on OP-104
1. With C2 key held down, push BEND MOD extremely right and set P-18 on OP-106 for 100% modulation.

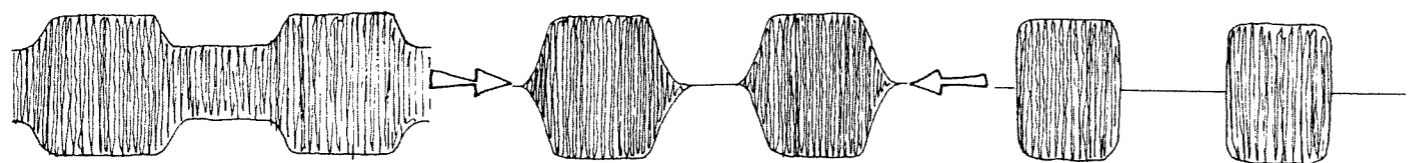

16. VCF ENVELOPE ATTACK

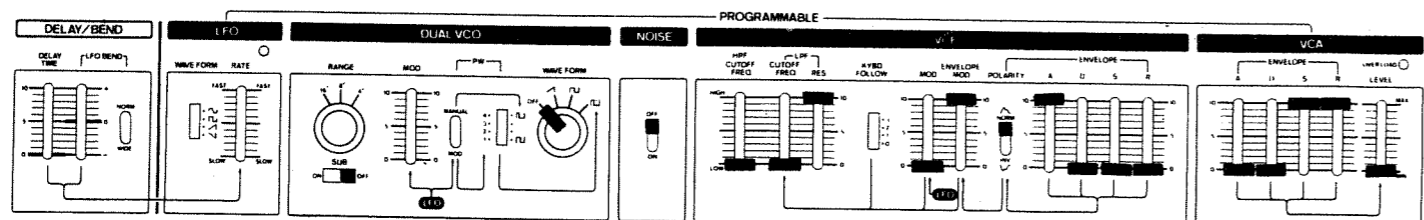

Test Point - TP-11 on OP-106
Ground Point - G-3 on OP-104

Attack Time is defined as the time from a keying to a sudden frequency drop.

- Depress C2 key and adjust P-23 on OP-106 so that Attack time becomes 3 sec.
- Measuring Attack time by listening to the sound is easier than observing the screen.

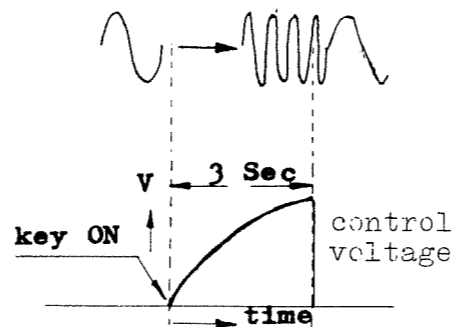

17. VCF ENVELOPE DECAY

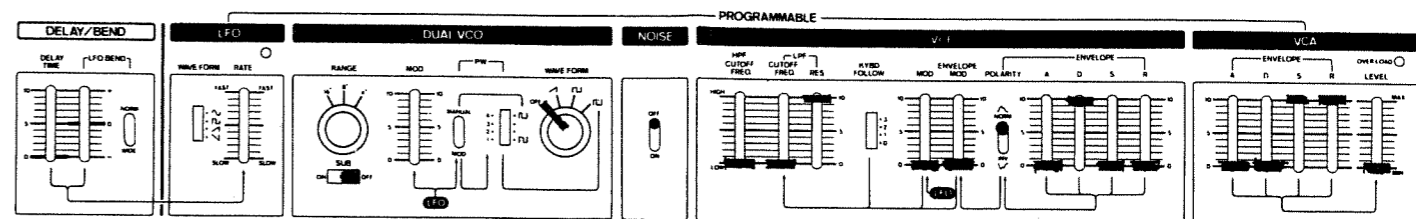

Test Point - TP-11 on OP-106
Grounding Point - G-3 on OP-104

- Adjust P-21 on OP-106 so that frequency lowers to 1/10 of its initial value in 4 sec after depressing C2 key.

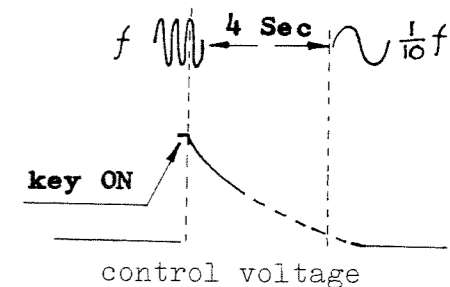

18. VCF ENVELOPE RELEASE

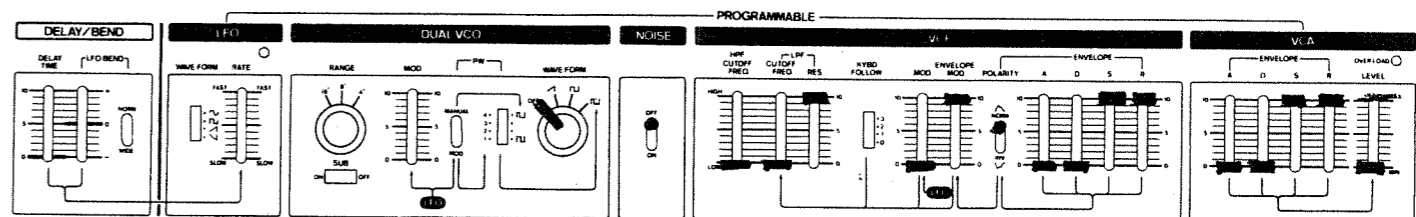

Test Point - TP-11 on OP-106
Grounding Point - G-3 on OP-104

- Adjust P-22 on OP-106 so that frequency lowers to 1/10 of its initial value in 4 sec after C2 key is released.
- The amplitude decreases as its frequency lowering. Increase scope vertical sensitivity accordingly.

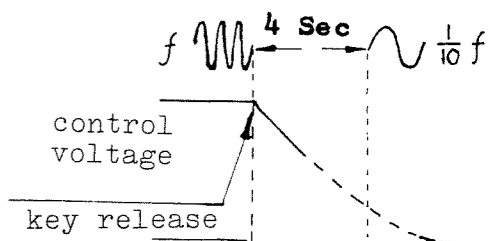

19. VCA ENVELOPE ATTACK

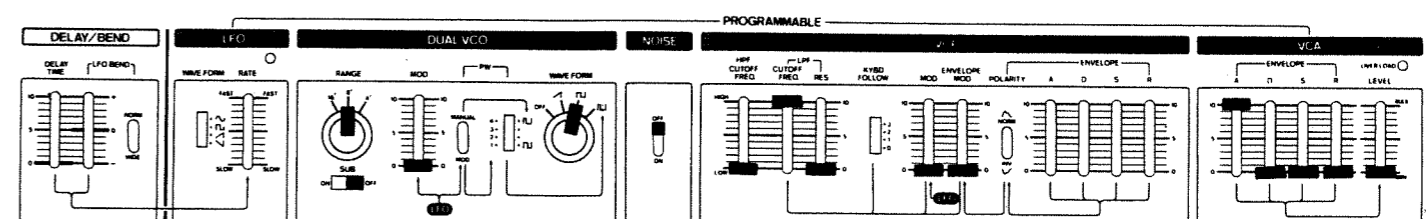

Test Point - TP-11 on OP-106
Grounding Point - G-3 on OP-104

- Adjust P-26 on OP-106 so that Attack Time is 3 sec with C2 key on.

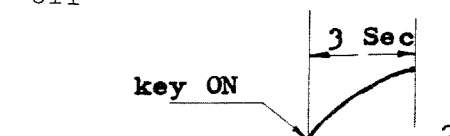

20. VCA ENVELOPE DECAY

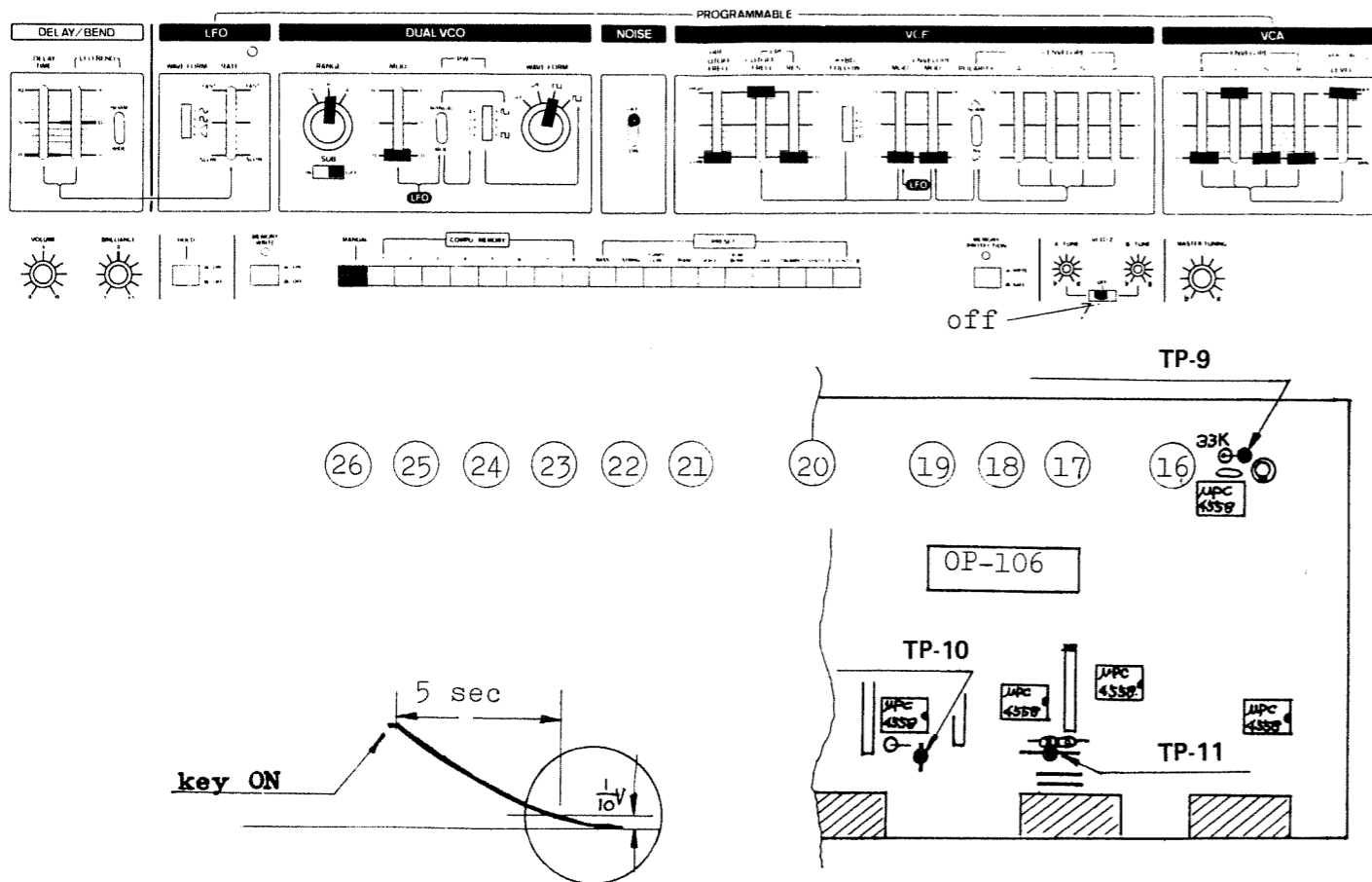

Test Point - TP-11 on OP-106
 Grounding Point - G-3 on OP-104

1. Adjust P-24 on OP-106 so that amplitude decreases to 1/10 in 5 sec after pressing C2 key.

21. VCA ENVELOPE RELEASE

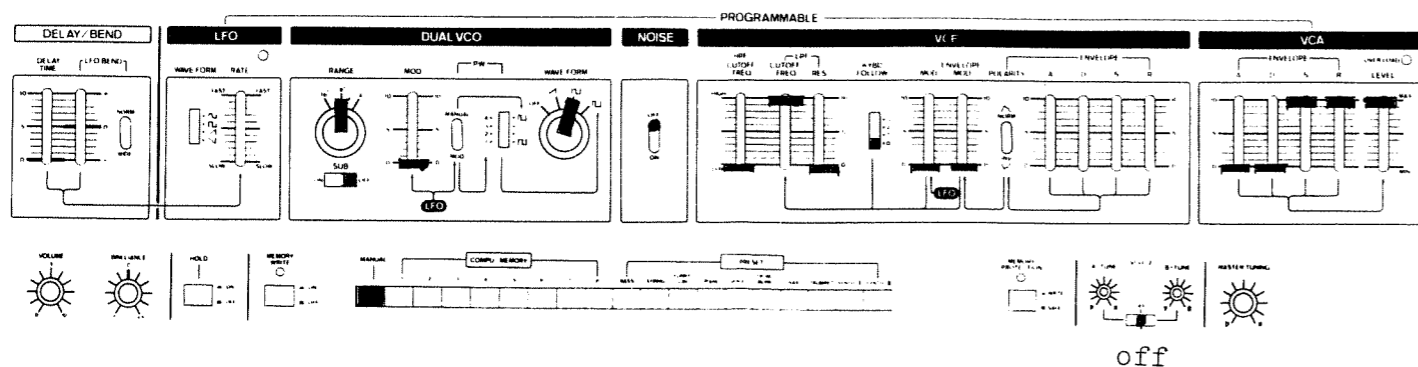

Test Point - TP-11 on OP-106
 Grounding Point - G-3 on OP-104

1. Adjust P-25 on OP-106 so that amplitude decreases to 1/10 in 5 sec after releasing C2 key.

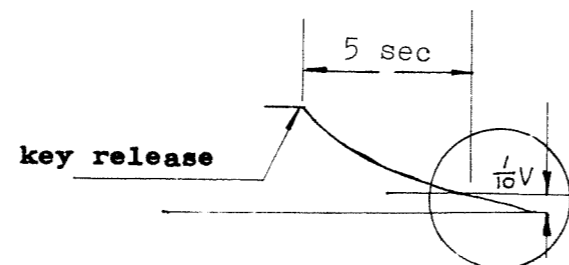

22. HPF CUTOFF FREQUENCY

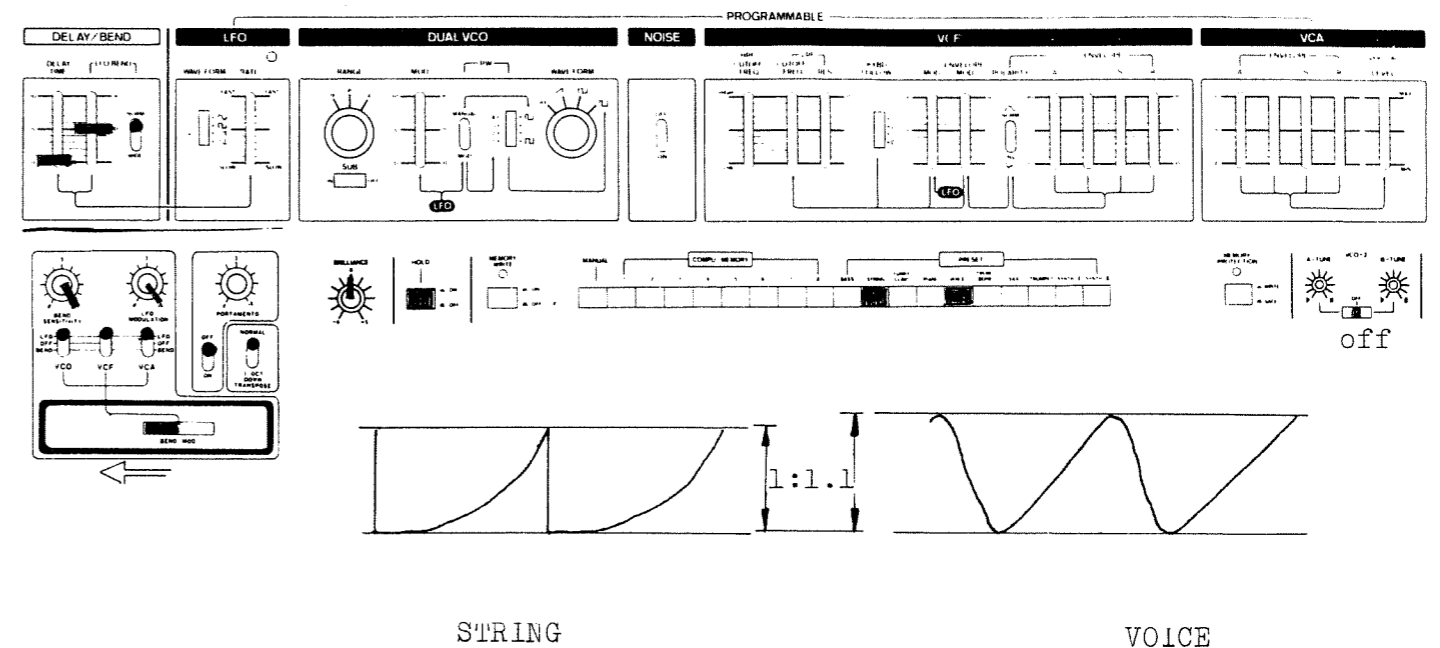

Test Point - TP-11 on OP-106
 Grounding Point - G-3 on OP-104

1. While pushing BEND MOD lever extremely left, adjust P-17 on OP-106 so that sound ratio of STRING and VOICE becomes 1:1.1 in amplitude.

23. NOISE LEVEL

Test Point - TP-9 on OP-106
 Grounding Point - G-3 on OP-104

1. Adjust P-16 on OP-106 for 5Vpp.

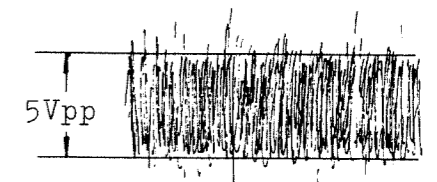

PARTS LIST

061-242E Chassis (case) no.242E
 072-265D Panel (top) no.265D
 072-268B Panel (bender) no.268B
 083-069B Side Panel no.69B right
 083-070B Side Panel no.70B left
 111-024 Foot (collar) no.24 black
 BU480 CA25
 115-003 Hinge no.3
 064-219B Music Rack Holder no.219B

004-011 Keyboard Assy SK-132G
 091-017A Endblock no.17A right
 065H52 Blind H52

KNOB. BUTTON

016-033 Knob no.33 slider
 016-056 Knob no.56 rotary small
 016-057 Knob no.57 rotary large
 016-009 Button no.9 black
 016-085 Button no.85 white
 016-086 Button no.86 red
 016-087 Button no.87 green
 016-088 Button no.88 yellow
 016-089 Button no.89 blue

SWITCH

Push

001-250 SUF-J2 interlock
 001-225 SUF-12 MEMO/WRIT. M PROTCT
 001-226 SUF-12A HOLD
 001-215 SDG5P-501-1 power 100V
 001-216 SDG5P-501-2 117V
 001-217 SDG5P-502 220/240V

Lever

001-237 LBC-42M-18K PW. NOISE, etc
 001-238 LBC-23M-18K TUNE A/B, PORTA, etc

Slide

001-182 SSB-022 RANGE (SUB on/off)
 001-205 SSB-023
 001-271 SSB-02332 LEVEL
 001-228 SQPR-2412P LFO WAVE, PW

Rotary

001-224 SRM-1043K15 VCO WAVEFORM
 001-234 SRM-1034K15 VCO RANGE

PCB

149-104B OP-104B Mother Board (PCB 052-364B)
 149-105D OP-105D Module Board (PCB 052-314D)
 149-105E or OP-105E compatible with OP-105D
 149-106C OP-106C Module Control (PCB 052-235C)
 149-107B OP-107B Bender Board (PCB 052-441B)
 149-108C OP-108C Control Board F (PCB 052-237C)
 149-109A OP-109A Control Board A (PCB 052-442A)
 149-110D OP-110D Control Board B (PCB 052-239D)
 149-111B OP-111B Control Board C (PCB 052-328B)
 149-112A OP-112A Level SW Board I (PCB 052-443A)
 149-113A OP-113A Level SW Board II(PCB 052-443A)
 149-134A OP-134A VCO-9 Control Board (PCB 052-468A)
 152-003B CV-3B KCV Board (PCB 052-440B)
 152-009A VCO-9A VCO-2 Board (PCB 052-439A)
 146-052F PS-52F Power Supply Board (PCB 052-327F)
 100V
 146-053F PS-53F Power Supply Board (PCB 052-327F)
 117V
 146-054F PS-54F Power Supply Board (PCB 052-327F)
 220/240V
 052H195A LED Mounting Board power switch
 or
 052-307

JACK

009-002 LJ-039-1-6 or stereo
 009-045 HLJ-0235-01-070
 009-025 HLJ-0102-01-040

POTENTIOMETER

Rotary

029-022 PB-4 Bender unit assy
 028-756 VM10RB10C K20 2MA
 028-762 VM10RB10C K20 50KB
 028-992 EVHDOAK15 50KB BRILLIANCE
 028-1109 EVHB8AK15 50KA VOLUME
 028-1118 EVHB8AK15 50KB M. TUNE
 030-951 EVHLWAD25B15 50KB A/B TUNE

Slide

029-355 EVAV17C16B54 50KB
 029-370 EVAV17C16C26 2MC
 029-426 EVAV23C16B54 50KB

Trimmer

030-469 SR-19R 47KB horizontal
 030-471 SR-19R 100KB
 030-660 SR-29R 4.7KB erect
 030-662 SR-29R 10KB
 030-666 SR-29R 47KB
 030-668 SR-29R 100KB
 030-493 CR-19R 4.7KB horizontal blue
 030-505 CR-19R 470KB
 030-689 89PR 20K helical
 030-688 89PR 500-ohm helical

RESISTOR

CRB $\frac{1}{4}$ FX $\frac{1}{4}$ W 1%

044-909 2K 044-846 100K
 044-844 6.8K 044-849 180K
 044-905 18K 044-926 1M
 044-887 20K

CAPACITOR

035-091 ECQF2334MZ polypropyrene
 035-278 ECQS1681KZ polystyrene
 035-279 ECQS1102KZ polystyrene

FUSE.	FUSEHOLDER
008-026	SGA0001 (1A) prim. 100/117V
008-063	CEE T500mA prim. 220/240V
008-028	SGA0002 (2A) sec. 100/117V
008-070	CEE T2A sec. 220/240V
012-003	TF-758 clip
022-104DN	Power transformer 100V
022-104CC	Power transformer 117V
022-104CD	Power transformer 220/240V
022H094	Coil 24M333

SEMICONDUCTOR

Transistor	
017-105	2SA1015-Y
017-022	or 2SB434-0
017-128	2SB596-Y
017-110	2SC1815-Y
017-135	2SD234-Y
017-140	or 2SD880-GR
017-016	2SK30ATM-GR FET
017-036	E-412 dual FET

Diode	
018-018	1N4003
018-059	1S1588
018-082	W-02 rectifier bridge
018-092	RD-5.1EB zener
018-015	SDT-1000 thermistor
019-022	GL-3AR1 LED power.memory
019-020	GL-3AR2 LED LFO,VCA

IC
020-095 MC1455
020-051 MC14001
020-046 MC14011
020-083 MC14016
020-076 MC14024
020-093 MC14025
020-075 MC14049
020-090 MC14051
020-091 MC14052
020-177 MC14070
020-178 MC14099
020-084 TC4069UBP only
020-031 μ A723DC
020-106 μ A7805DC
020-108 μ A7815UC
020-097 μ PC4558C
020-101 μ PC741C
020-181 μ PC5101C-E
020-032 μ A726HC
179-021 μ PD8048C-12
020-141 SN74LS175N
020-054 LM311
020-100 TL082
020-039 DN819

020-160 BA662A
020-096 BA662B
non BA662S factory selected

For VCF, there are factory selected BA662s painted in particular colors according to the electrical characteristics.

When replacing, use the BA662 in the same color, and when ordering, denote color as well as BA662S.

048-046	Heat Sink No.46
055-003	Rechargeable Battery 4N-100AAS

HOLDER
064H55 H55
064-184 No.184 (Module, Module Cont. VCO-9 right)
064-185 No.185 (Module, Module Cont. VCO-9 left)
064-186 No.186 (Module, Module Cont. VCO-9-Mother Board)
064-187 No.187 (Power Switch)
064-203 No.203 (Bender Panel-Bender Board)
064-204 No.204 (Bender Panel-Bender Board)
064-205 No.205 (Bender Unit)
064-210 No.210 (Bender Panel-Bender Board)
064-219 No.219 (Music Rack-Panel)
064-226 No.226 (End Block)
064-227 No.227 (Side Panel)
064-231 No.231 (Control Board-Panel)
064-232 No.232 (Bender Panel-Keyboad)
064-233 No.233 (Battery)
064-239 No.239 (Mother Board-Chassis)
064-249 No.249 (Push Switch)
064-230 No.230 (Control Board-Panel)

CONNECTOR	
010-177	PICD-9P-T1 Mother Board male
010-178	PICD-9S-TL1 Module, Module cont, VCO-9 female

Erect	Wafer Terminal pin	Right Angle	
010-182	5045-02A	2-pin	010-192 5046-02A
010-183	5045-03A	3-pin	010-193 5046-03A
010-184	5045-04A	4-pin	010-194 5046-04A
010-185	5045-05A	5-pin	010-195 5046-05A
010-186	5045-06A	6-pin	010-196 5046-06A
010-187	5045-07A	7-pin	010-197 5046-07A
010-188	5045-08A	8-pin	
010-189	5045-09A	9-pin	010-199 5046-09A
010-190	5045-10A	10-pin	010-200 5046-10A

COVER			
065-065	No.65	065-190	No.190
065-066	No.66	065-232	No.232
065-143	No.143		

Although some equivalent ICs are interchangeable, however, due to characteristic difference, use the same IC when specified in the circuit diagram.

Roland®

10576

UPC 10576

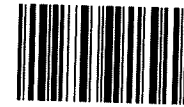

10901

Roland®