

# TR-626 SERVICE NOTES *First Edition*

## SPECIFICATIONS

- Memory Capacity** : 48 Preset Rhythm Patterns  
(Pattern Group A, B & C, each 16 patterns)  
48 User's Programmable Rhythm Patterns  
(Pattern Group D, E & F, each 16 patterns)
- Track** : 6 (999 measures max. in total)
- Step** : 1 to 16 / measure
- Tempo** : ♩=40-240
- Output** : 6.0Vpp max. (Mono OUT)  
2.0Vpp max. (Individual OUT)
- Noise Level** : Less than -78dBm IHF-A
- Trigger Out** : +5V, Approx. 18ms pulse (Rim Shot)
- Tape In/Out** : 600 baud
- Tape Sync Out** : -7dBm
- Power Source** : 9V DC dry cell (UM-3) 6 pcs  
or AC Adapter BOSS PSA series
- Current Draw** : 50mA DC at 9V
- Power Consumption** : 450mW
- Battery Life Expectancy** : Approx. 16 hours (UM-3)
- Dimensions** : 400 (W) x 194 (D) x 56 (H) mm  
15-3/4 x 7-5/8 x 2-3/16 in.
- Weight** : 1.3 kg/2 lb. 14 oz. (including dry cells)
- Accessories** : Connection Cable II-250  
Dry cell SUM-3 6 pcs.
- Options** : AC Adapter BOSS PSA series  
Pedal Switch DP-2  
Memory Card M-128D (RAM 16K bytes)

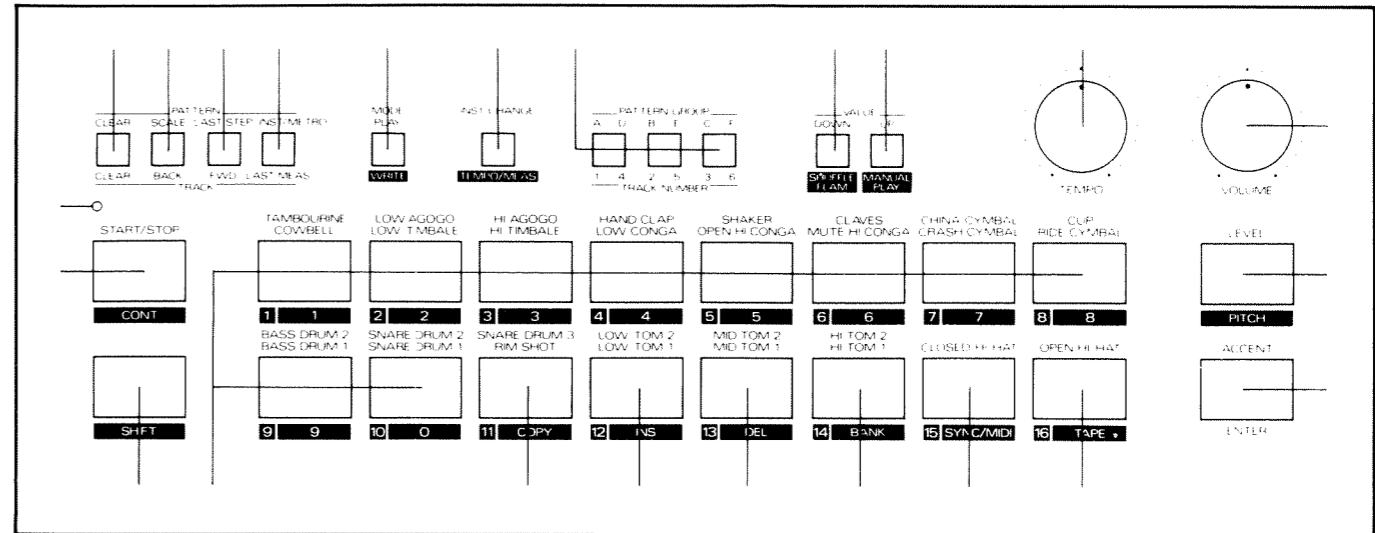

## CHANGE INFORMATION

### CPU IC5 Main Board

Three CPU's as of the date of this manual Differences among them are as listed below

Since the updated newest CPU is upward compatible from the predecessors, it is a preferable replacement.

## 変更案内

### CPU IC5 メインボード

本サービスノート発行時点で、下表の通り3種類のCPUが使用されています。

表中3のCPUは、上位コンパチブルなので、補修するには3のCPUを使用して下さい。

	Name	Part No.	Serial No.	Type	Change
1	HD63701Y0P	15179270	up to 800199	w/internal one time PROM	Program:See description below.
2		15179268	820200-823199		
3	HD6301Y0D09P	15179271	823200-up	w/internal MASK ROM	Type of internal ROM (program is the same as in 15179268) (プログラムは15179268と同じ)

### Improvements On The CPU Program ( 2 and 3 in the above list)

\* Decrease flickering in tempo indication on the LCD.

\* Implement the following features.

Transmit/receive MIDI Exclusive message.

Transmit a song position pointer when a measure in the ongoing track is directly specified from the main key.

### プログラム改良点 (上記2および3)

\* LCD上のテンポ表示のチラツキ軽減。

\* 下記の機能を追加

MIDI Exclusive メッセージを送受信する。

トラック中の小節がメインキーにより直接指定された場合、ソングポジションポインタを送信する。

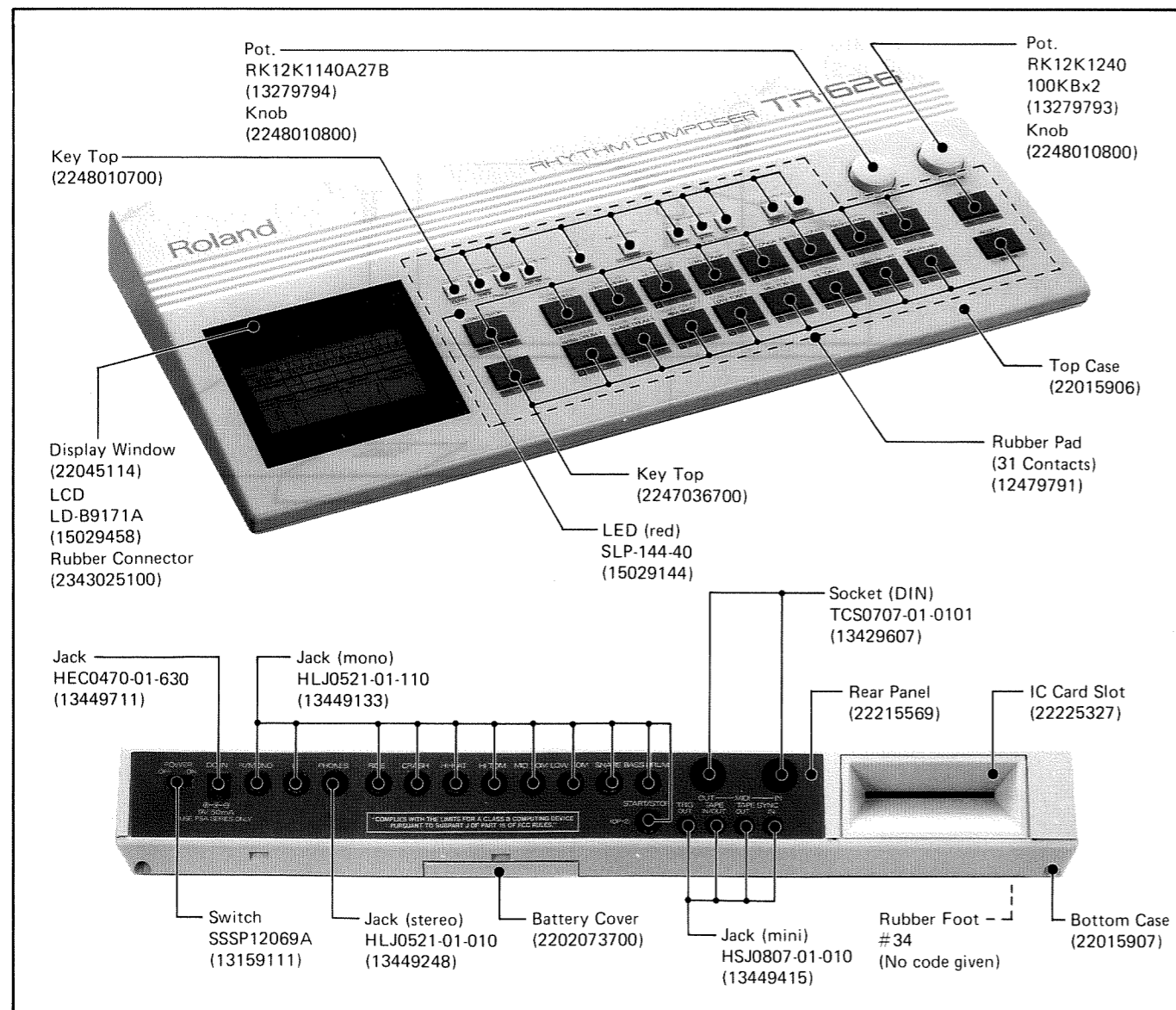

EXPLODED VIEW 分解図

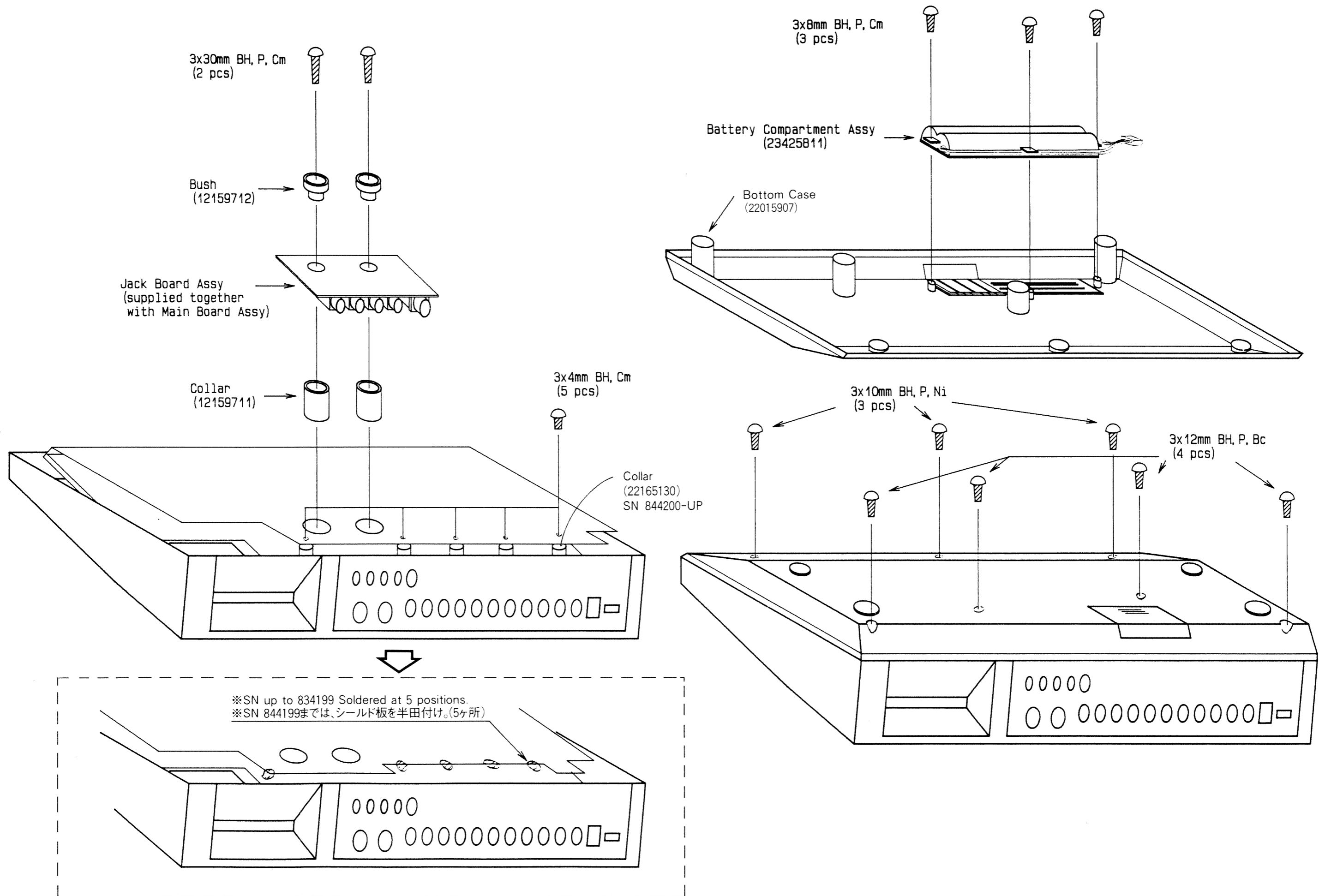

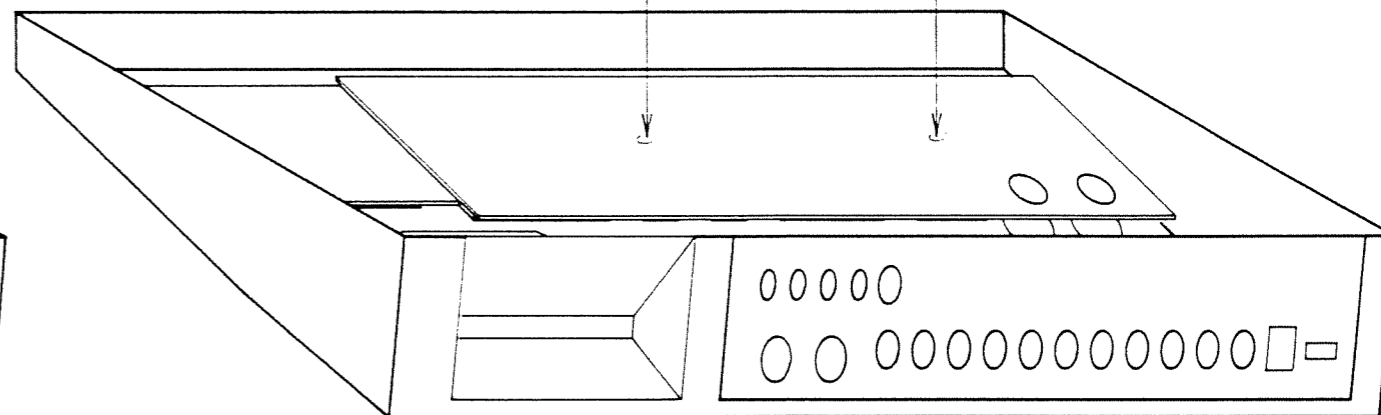
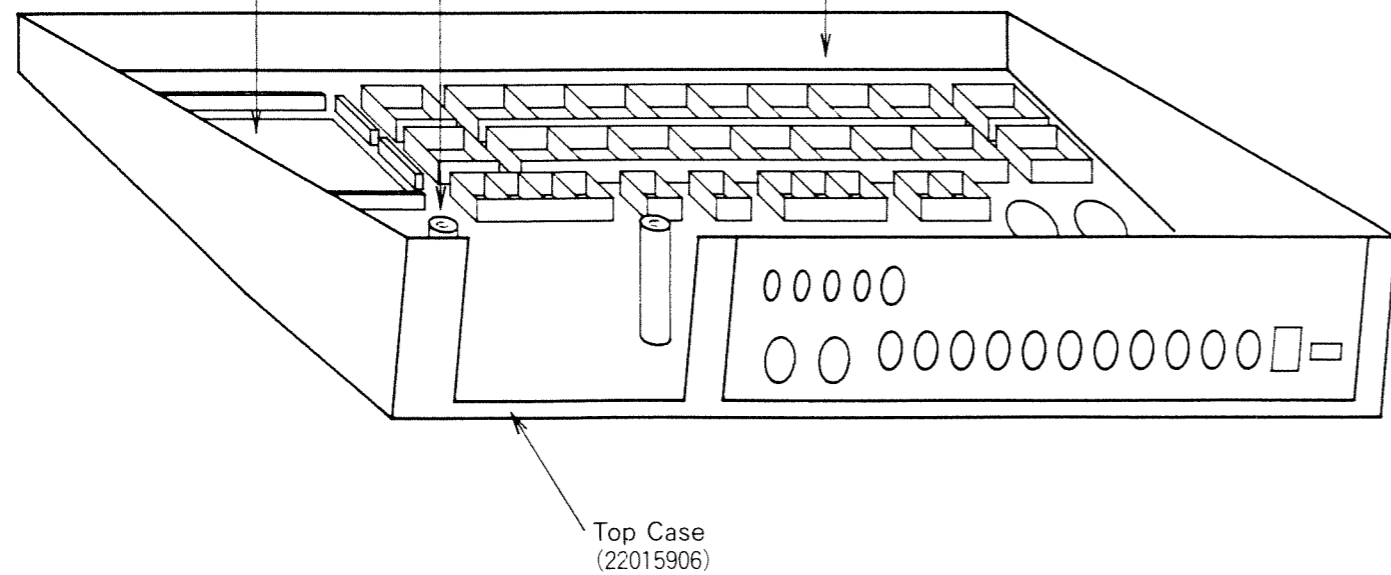
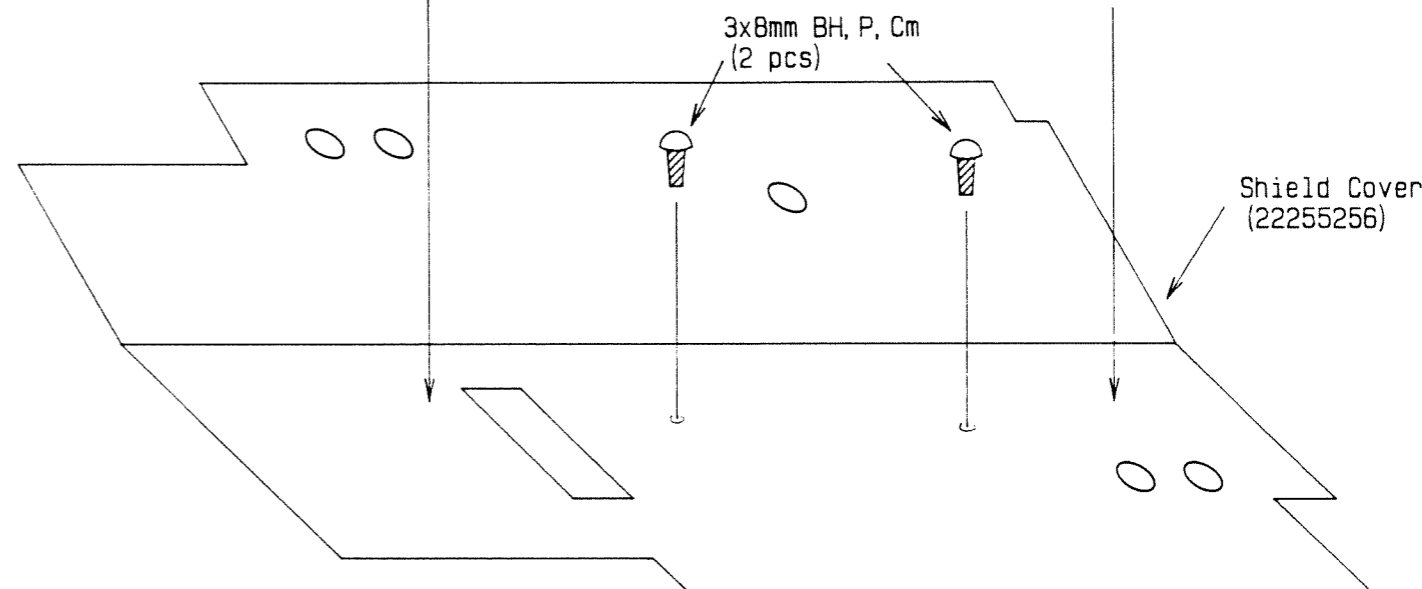
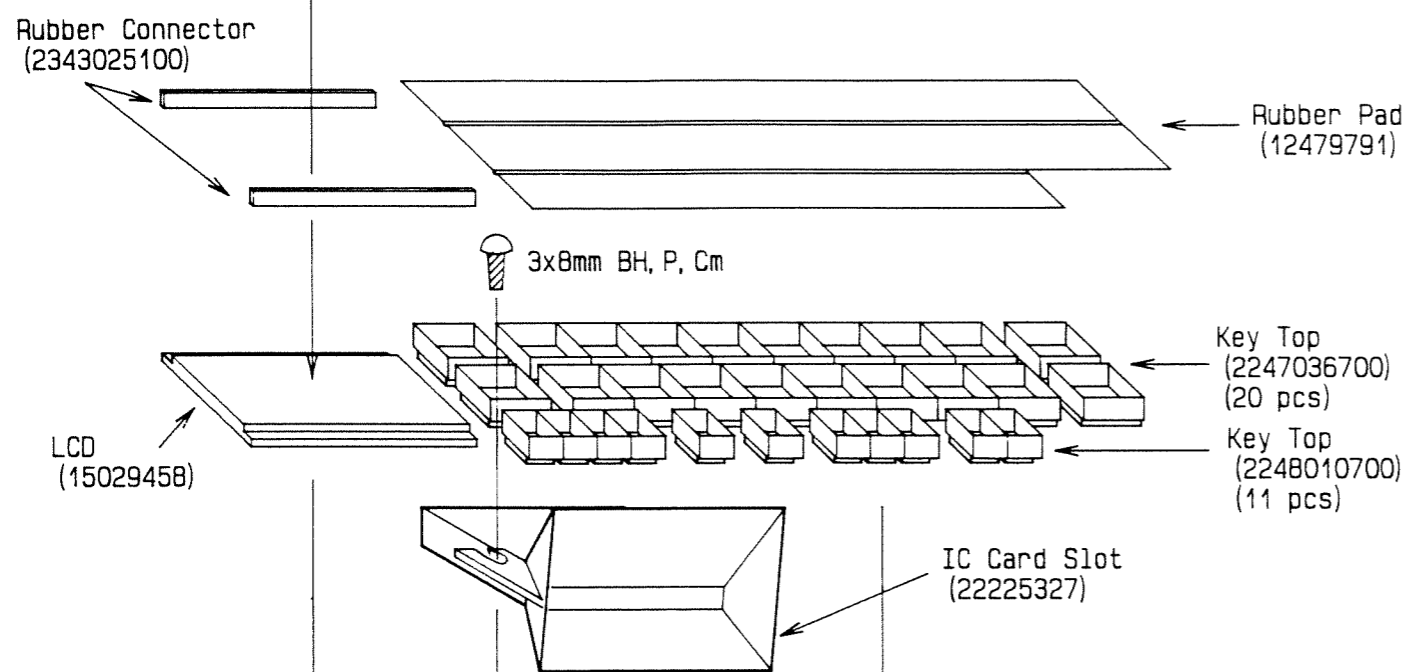
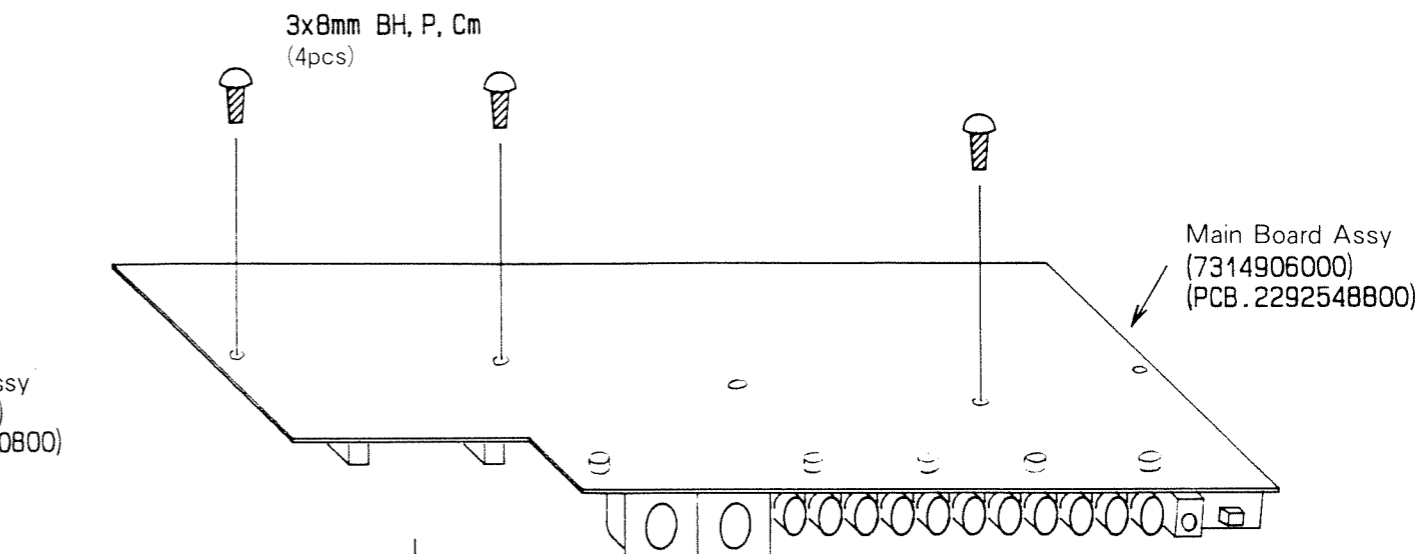
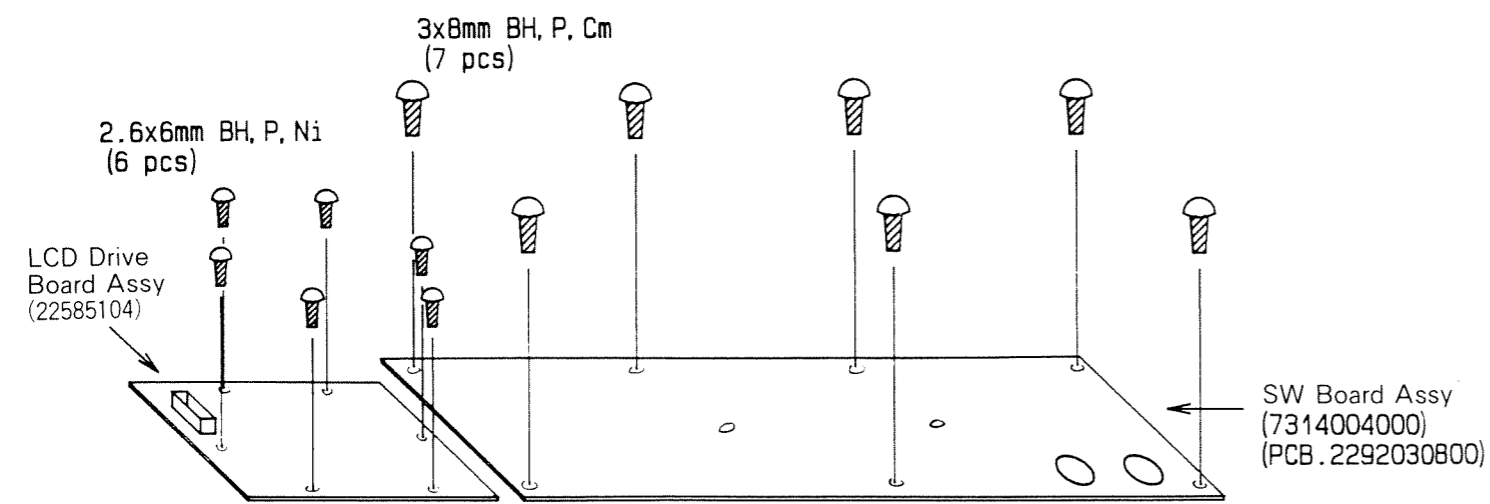

## PARTS LIST

## パーツ・リスト

## CASING ケース

22015906	Top Case	トップケース
22015907	Bottom Case	ボトムケース
2202073700	Battery Cover	電池カバー
23425811	Battery Compartment Assy (including the following 4 parts)	電池ボックス完成品 (下記4点を含む)
2202073900	Compartment	電池ボックス
2345015500	Terminal Plate (+)	端子板
2345015600	Terminal Spring (-)	端子板
-----	Connector 4p w/leads	リード付コネクタ
22215569	Rear Panel	リアパネル
22225327	IC Card Slot	ICカード エスカッション
22045114	Display Window	LCD窓

## KNOB, BUTTON シャツ, ボタン

2247036700	Key Top (large)	モールド ツマミ(大)
2248010700	Key Top (small)	モールド ツマミ(小)
2248010800	Knob	丸ツマミ

## PCB ASSY 基板完成品

7314906000	Main Board (pcb 22925488 1/2)	メイン基板
7314905000	Including Jack Board Jack Board (pcb 22925488 2/2)	ジャック基板を含む ジャック基板
7314004000	Switch Board (pcb 22920308) (Common to TR-505)	スイッチ基板
22585104	LCD Drive Board Assy No replacement for individual parts on LCD Drive Board, including pcb and IC. LCDドライブ基板の単独部品(IC, 基板等)に対する補修品は用意されておりません。	LCDドライブ基板

## JACK ジャック

13429607	TCS0707-01-0101	DIN	MIDI IN, MIDI OUT
13449711	HEC0470-01-630		DC IN
13449415	HSJ0807-01-010	mini	TRIG OUT, TAPE IN/OUT TAPE SYNCHRO IN/OUT
13449248	HLJ0521-01-010	stereo	PHONES
13449133	HLJ0521-01-110	monaural	START/STOP, R/MONO, L RIDE, CRASH, HI-HAT HI TOM, MID TOM, LOW TOM SNARE, BASS DRUM

## POTENTIOMETER ボリューム

13279793	RK12K1240 100KBx2	VOLUME
13279794	RK12K1140A27B	TEMPO

## SWITCH スイッチ

12479791	Rubber Pad	ゴムスイッチ
13159111	SSSP12069A	slide スライドスイッチ

## CONNECTOR コネクター

13439402	IL-S-4P-S2UX2-E	4p	Main Board
13439351	IL-S-6P-S2L2-EF	6p	Jack Board
13439297	IL-S-8P-S2T2-EF	8p	Switch Board
13439321	MOLEX 5124-03BHPB	3p	Switch Board
13429191	75080920	34p	Memory Card
2343025100	Rubber Connector		LCD

## CERAMIC RESONATOR 発振子

12389729	CSA4.00MG	4.0MHz
12389809	CST6.40MT	6.4MHz

## LCD 液晶表示器

15029458	LD-B9171A
----------	-----------

## IC

15179268	or (15179270)	HD63701YOP	ZTAT CPU (w/one time PROM)
	or	HD6301Y0D09P	(w/MASK ROM)
15179271			Containing the same program, (exclusive to TR-626), 15179268 and 271 are compatible with each other. See "CHANGE INFORMATION". Replacement CPU will be 271 only. プログラムバージョンが同じなので、15179268と271は互換性があります。 「変更案内」参照。補修品は271が供給されます。
15179846	μPD23C2001C	MASK ROM	(SOUND) IC15
15179378	MB8464A-15LL-SK	CMOS S-RAM	IC2
15229825	MB63H114PF	gate array	multiple address counter IC14
15229880	MB671189PF	gate array	IC13
15229881	μPD65006GF-198	gate array	IC1
15229867	BU3904S R11-0001	custom IC	FSK MOD/DEMOD IC10
15159113T0	TC4051BP	CMOS	single 8-channel multiplexer
15159116B0	M4069UBP	CMOS	hex inverter
15159129H0	HD14053BP	CMOS	triple 2-channel multiplexer
15169512X0	SN74HCU04	H-CMOS	hex inverter
15169515X0	SN74HC00	H-CMOS	quad 2-input NAND gate
15169571X0	SN74HC238	H-CMOS	3-to-8 line decoder
15189136	M5218L	Op amp	
15189194	BA6993	comparator	
15219187	M51958AL	reset IC	
15229712	PC-900	optoisolator	

## TRANSISTOR トランジスタ

15129602	2SD-667C	NPN
15129612	2SD-1469R	NPN
15129154	DTA-144EA	
15129181	DTC-144TF	

## DIODE ダイオード

15019125	ISS-133		
15019209T0	S-5500G	rectifier	整流器
15019413D0	MTZ5.1B-T77	5.1V zener	ツェナー
15019509	MTZ5.6C	5.6V zener	ツェナー
15029144	SLP-144-40	LED	red 赤

## INDUCTOR コイル

12449272	GM50510152	filter bead inductor
12449266	BL01RN1-A62	ferrite bead inductor

## RESISTOR ARRAY 抵抗アレイ

13919118	RGSD16L104G	ladder network	DAC
13910107	RGLD 8x332J		

## WIRING ASSY ワイヤリング完

23495604	6P, 7P, 8P	main board
----------	------------	------------

## MISCELLANEOUS その他

13629141	Capacitor	Philips 122.5109 10μF 16V
13549128	Capacitor	0.082μF 50vj ±5% Mylar
12569255	Lithium Battery	M2B-C200 3V リチウム電池
12569105	Dry Cell	SUM-3S 1.5V 単三乾電池
-----	Rubber Foot #34	ゴム足
22255256	Shield Cover	シールド板
22165130	Collar	PB-1-S カラー(スベサ) shield cover
12159711	Collar	NA-315 カラー(スベサ) jack board
12159712	Bushing	NB-300 ブッシュ jack board

1 2 3 4 5 6 7 8 9 10 11 12 13 14 15 16 17 18 19 20 21 22 23 24 25 26 27 28 29 30 31 32 33 34 35 36 37 38 39 40

# BLOCK DIAGRAM

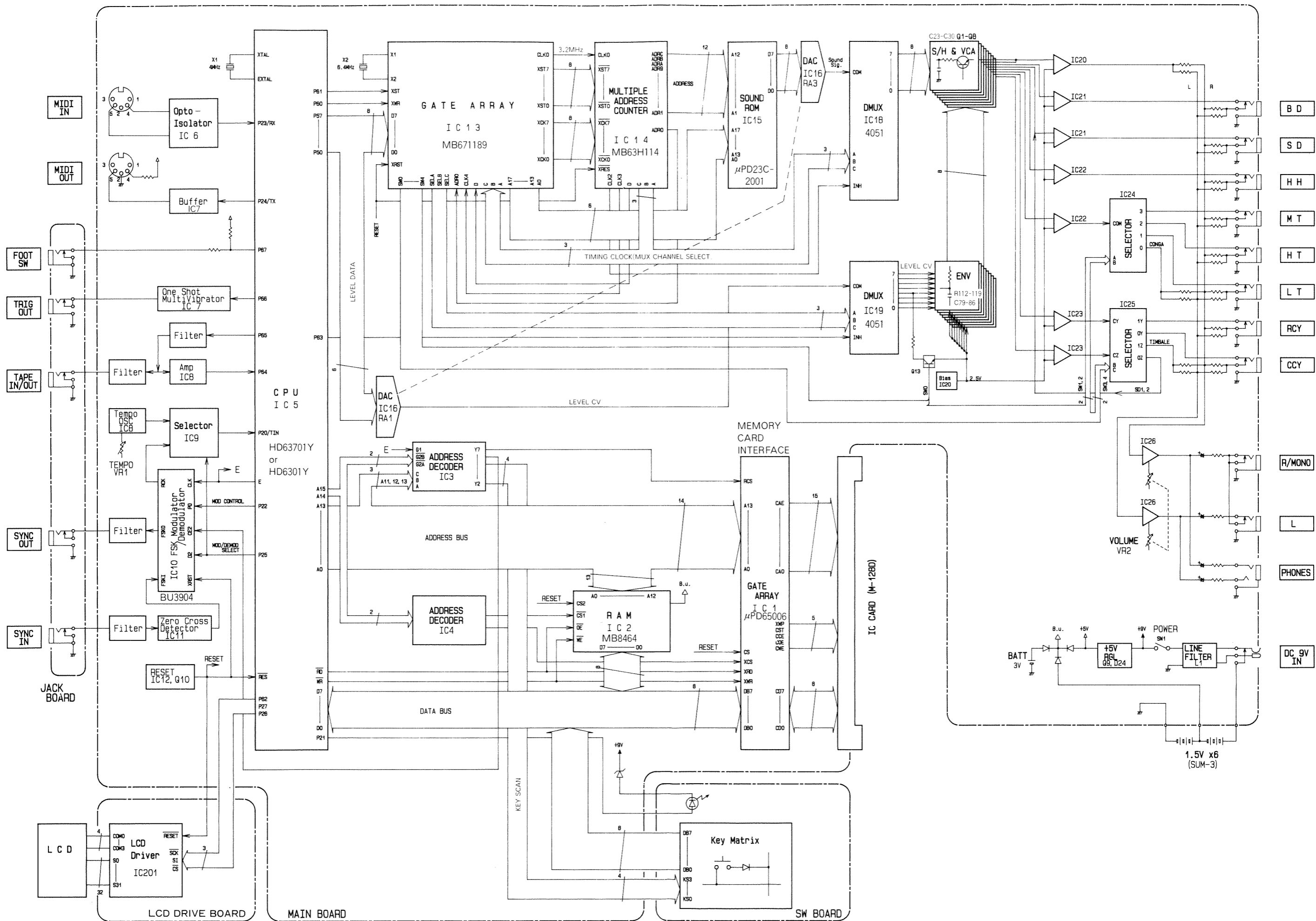

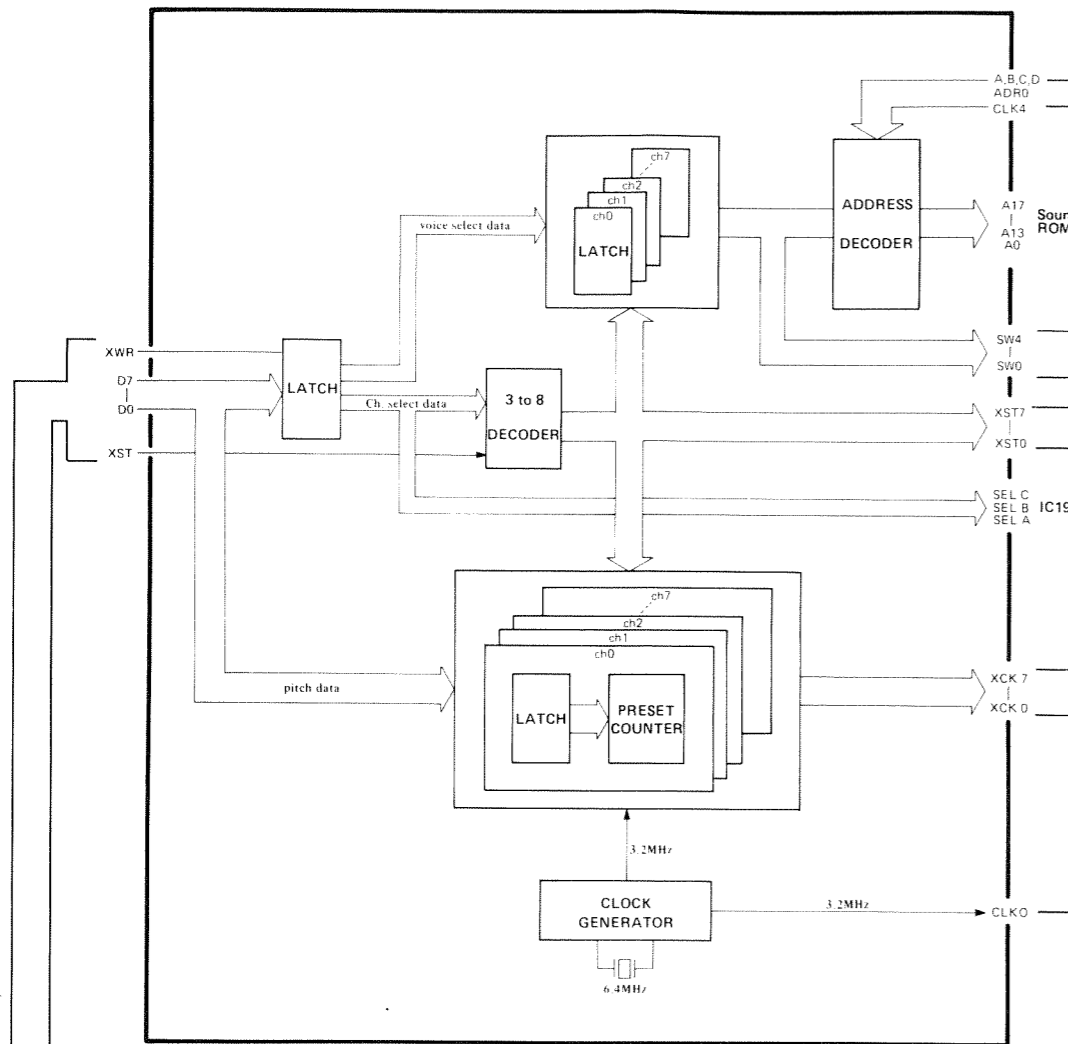

Fig. 1 IC13 MB671189 BLOCK DIAGRAM

(CLK3)

SW	"L"	"H"
0	Open Hi-Hat	Closed Hi-Hat
1	Hi Tom 1, 2 Low Conga, Open Hi Conga	Low Tom 1, 2 Mid Tom 1, 2
2	Low Tom 1, 2 Low Conga, Open Hi Conga	Hi Tom 1, 2 Mid Tom 1, 2
3	Crash Cymbal China Cymbal	Ride Cymbal Cup
4	Snare Drum 1, 2	Low Timbale, Hi Timbale

Fig. 3 OUTPUT CHANNEL SELECT

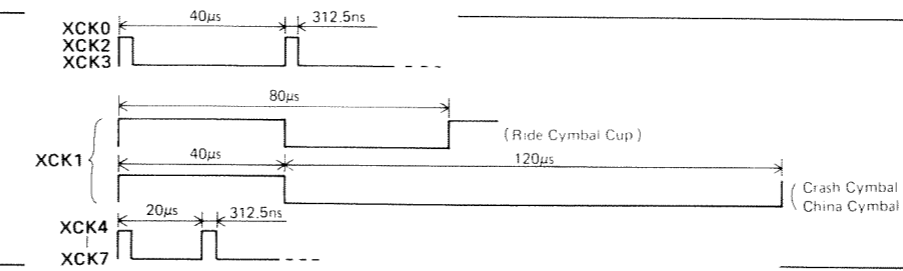

Fig. 4 ADDRESS COUNTER CLOCK PULSES (Pitch at zero)

Fig. 5 GATE ARRAY MB63H114 Multiple Address Counter

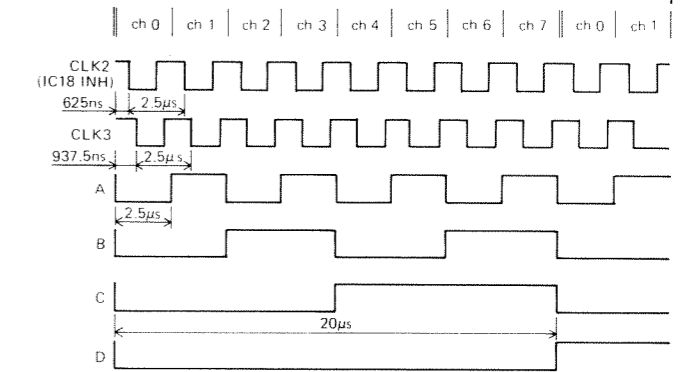
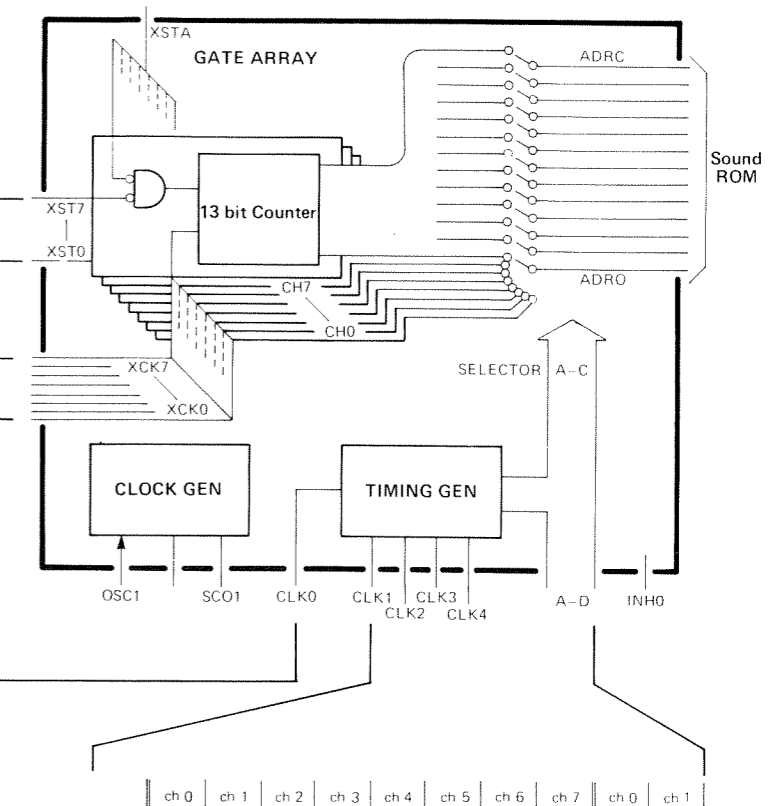

Fig. 6 MULTIPLEXING TIMING DIAGRAM

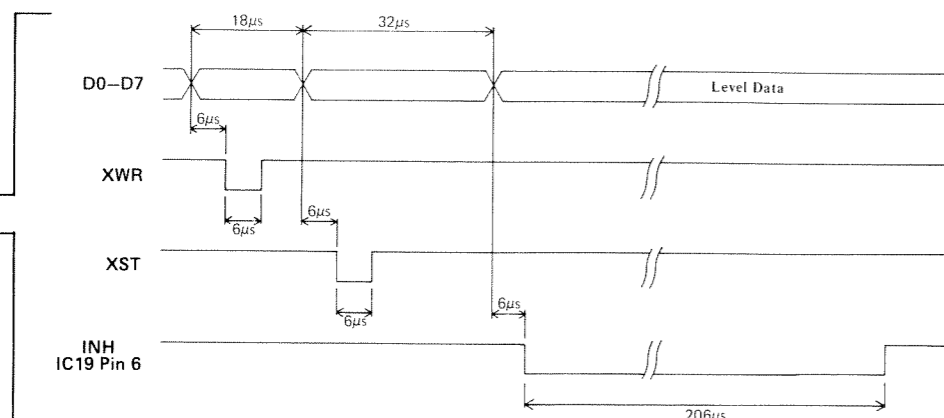

Fig. 2 IC13 DATA LATCH TIMING DIAGRAM

Table 2 SOUND ROM ADDRESS MAP

ch	voice	A0	A1 - A12	A13	A14	A15	A16	A17	Bytes
0	SD1	AD0	AD1 - AD12	0	1	1	1	0	8K
	SD2	AD0	AD1 - AD12	1	1	1	1	0	8K
	LTB	AD0	AD1 - AD12	0	1	1	1	1	8K
	HTB	AD0	AD1 - AD12	1	1	1	1	1	8K
1	CCY	AD0	AD1 - AD12	AD(-2)	AD(-1)	0	1	0	32K
	RCY	AD0	AD1 - AD12	AD(-1)	0	1	1	0	16K
	CHY	AD0	AD1 - AD12	AD(-2)	AD(-1)	0	1	1	32K
	CUP	AD0	AD1 - AD12	AD(-1)	0	1	1	1	16K
2	O.HCG	AD0	AD1 - AD12	0	0	0	0	0	8K
	LT1	AD0	AD1 - AD12	1	0	0	0	0	8K
	HT1	AD0	AD1 - AD12	0	1	0	0	0	8K
	MT1	AD0	AD1 - AD12	1	1	0	0	0	8K
	LCC	AD0	AD1 - AD12	0	0	0	0	1	8K
	LT2	AD0	AD1 - AD12	1	0	0	0	1	8K
3	OHH	AD0	AD1 - AD12	1	1	1	0	0	8K
	CHH	AD0	AD1 - AD12	1	1	1	0	1	8K
	RIM	0	AD1 - AD12	0	1	1	0	0	4K
	SD3	0	AD1 - AD12	0	1	1	0	1	4K
5	BD1	1	AD1 - AD12	0	1	1	0	0	4K
	BD2	1	AD1 - AD12	0	1	1	0	1	4K
	HCP	0	AD1 - AD12	0	0	1	0	0	4K
	CLAVES	0	AD1 - AD12	1	0	1	0	0	4K
6	M.HCG	0	AD1 - AD12	0	0	1	0	1	4K
	SHAKER	0	AD1 - AD12	1	0	1	0	1	4K
	CB	1	AD1 - AD12	0	0	1	0	0	4K
	TA MB.	1	AD1 - AD12	1	0	1	0	0	4K
7	L.AGOGO	1	AD1 - AD12	0	0	1	0	1	4K
	H.AGOGO	1	AD1 - AD12	1	0	1	0	1	4K

Table 1 SOUND LOCATION

ch	Voice		Bytes
0	Snare Drum 1	Low Timbale	8K
	Snare Drum 2	Hi Timbale	
1	Crash Cymbal	China Cymbal	32K
	Ride Cymbal	Cup	
2	Open Hi Conga	Low Conga	8K
	Low Tom 1	Low Tom 2	
	Mid Tom 1	Mid Tom 2	
	Hi Tom 1	Hi Tom 2	
3	Open Hi-Hat	Closed Hi-Hat	8K
	Rim Shot	Snare Drum 3	
5	Bass Drum 1	Bass Drum 2	4K
6	Hand Clap	Mute Hi Conga	4K
	Claves	Shaker	
7	Cowbell	Low Agogo	4K
	Tambourine	Hi Agogo	

## CIRCUIT DESCRIPTIONS

### GENERAL

The TR-626 is a multiple-sound rhythm machine that reproduces up to 8 rhythm voices simultaneously by reading multi sound (waveform) data, in time-division format, stored in the sound ROM.

These sound data in the sound ROM (IC15) are called by addresses generated in the 8-channel address counter (IC14) in sequence; converted into analog equivalent at DAC (IC16, RA3) output; delivered to S/H circuits through demultiplexing and then given the suitable contour at VCA by envelope generator outputs.

With the TR-626 the pitch of a rhythm sound can be shifted by changing addressing speed, i.e. time interval of a counter clock (XCK0-XCK7) to the multi-address counter IC14. The new Roland custom gate array MB671189PF (IC13) generates variable counter clocks as well as upper address bits needed to access a 2 Mbyte ROM.

The very basic circuit concept of multi-addressing system already appeared in Roland TR-707 and TR-505. Those discrete circuit components generating upper address bits are incorporated in one chip (MB671189PF) on the TR-626.

Since this section of the description skips some basic functions of the multi-address counter (only shows block diagram and pin configuration), readers not familiar with multi-address counter are encouraged to read the detailed description on the TR-707 and TR-505 service notes.

### DETAIL

#### 1. Gate Array MB671189PF (IC13, Main Board)

The gate array features the following three major functions:

- Generates address counter (IC14) start pulses (XST0-XST7)
- Decodes sound ROM (IC15) addresses
- Generates address counter (IC14) clocks (XCK0-XCK7)

When a rhythm starts, the CPU IC5 places on P50 - P57 the data specifying sound channel to be activated and a sound in the channel. The data are latched into the gate array IC13 on an L to H transition of XWR and sent to DMUX IC19 as a channel select code (SELA, B and C). The IC19, in turn, passes a level CV onto the envelope generator in the correct channel. The next data from the CPU determines the pitch of the sound and is held by the CPU until latched by a counter start pulse (XST0 - XST7) described below.

## 回路解説

### 概要

TR-626はマルチプル音源方式のリズムマシンです。音源ROM (IC15) に記憶されている複数の音源(波形)データを8チャンネルのアドレスカウンタ (IC14) で順次読み出し(時分割)、DAC (IC16, RA3) でアナログ電圧に変換、デマルチプレクス回路で指定のS/H回路に入力し、サンプル/ホールドし、これに楽器の種類に応じたエンベロープを与えます。

TR-626では音源データの読み出しスピード(アドレス)を変えることにより、ピッチを変化させることが出来ます。このためにはマルチアドレスカウンタ (IC14) のカウンタクロック (XCK0-XCK7) の周期を可変にする必要があります。ゲートアレイ IC13 (MB671189PF) は、可変周期のクロックを生成するとともに、2Mビットの音源データを読み出すための上位アドレスも生成します。

マルチプル音源方式はTR-707、TR-505等で採用されているものと基本的には同じですが、ディスクリットで組み立てられた上位アドレス生成回路がTR-626ではゲートアレイ IC13 に内蔵されています。したがって、本解説で不明な点についてはTR-505のサービスノートも参照して下さい。(アドレスカウンタ IC14 の詳細は本解説では省略していますが、TR-505では詳しく説明されています。)

### 詳細

#### 1.ゲートアレイ MB671189PF (IC13, メインボード)

主な機能は次の三つです。

- アドレスカウンタ (IC14) スタート用パルスの発生 (XST0-XST7)
- 音源ROM (IC15) 用のアドレスデコーダ (A0, A13-A17)
- アドレスカウンタ用のカウンタクロックの発生 (XCK0-XCK7)

CPU (IC5) から発音すべき音源チャンネルおよび、そのチャンネル内の音源を指定するデータがP50 - P57を通じてD0 - D7へ送られて来ます。

これらのデータは、XWRのLからHへの立上りでラッチされ、このうち音源チャンネルを指定するコードはチャンネルセレクト信号 (SELA, B, C) としてDMUX IC19へ送られます。IC19は、このコードに応じて、レベルCVを指定のチャンネルのエンベロープ発生回路へ出力します。

次に発生させる音源のピッチを指定するデータがCPUから送られて来ますが、このデータは後述のカウンタスタートパルス (XST0-XST7) によってラッチされるので、それ迄はCPUが出力し続けます。

On an L to H transition of XST, the channel select signal being latched is made become a counter start pulse (XST0-XST7) of the selected channel by the 3-to-8 decoder. The counter start pulse also latches the pitch data and sound source select data into the correct channel.

### 2. Sound ROM (IC15) Address

The address bits A13 and A14 of channel 1 in Table 2 are somewhat different from those in other channels. The following description takes Crash Cymbal (CCY) address as an example.

To gain access to CCY's 32 kbyte memory location, 15 (2<sup>15</sup> = 32K) address bits are required. The address must proceed at 40μs steps (when pitch shift is set at zero). The total bits the address counter can furnish are 13 bits: the remaining 2 bits must keep pace with the 13 bits.

Because the address counters are configured as non-free-running, they stop upon counting up all 1's which are equivalent to the address of the end location of an 8 kbyte memory space. To prolong the counter running time to cover all the 32 kbyte locations, the highest bit (ADRC) from the counter must be the 15th bit. That is, all counts (ADR0 - ADRC) are to be shifted up by 2 orders with respect to other channels. On the contrary, A13 and A14 address signals are shifted down to LSB (bit 0 and bit 1, respectively). The gate array IC13 generates bits 0 and 1 and applies them to the sound ROM IC15 as A13 and A14 when channel 1 is selected (Fig. 7).

The IC13 also feeds a clock whose interval is equal to bit 1 (160μs with pitch set at 0) to channel 1 counter as the XCK1 (Fig. 4). Triggered on this XCK1, the channel 1 counter will deliver the count ADR0 as shown in Fig. 7, which is considered as bit 2 of the address system whose LSB (bit 0) steps at 40μs interval.

#### NOTE:

ADR0 output from IC14 is indirectly applied to the sound ROM via IC13. The A0 column in Table 2 indicates that ADR0 must be at fixed level, 1 or 0 for channels 4-7. The IC13 selects a level according to channel selected before sending ADR0 to the sound ROM.

XSTが“L”から“H”になると、それ迄ラッチされていたチャンネルセレクト信号が3 to 8 デコーダによってデコードされ、該当するチャンネルのカウンタスタートパルス (XST0-XST7のうちのいずれか) となります。このスタートパルスは同時に、ピッチデータおよび既にラッチされている音源セレクトデータを該当チャンネルへラッチします。

### 2.サウンドROM (IC15) のアドレス

Table 2のアドレスマップを見ると、チャンネル1のA13, A14のアドレス信号が他のチャンネルと異なっています。これについてCrash Cymbal (CCY) を例にとって説明します。

CCYの32Kbyteのメモリロケーションにアクセスするには、15ビット (2<sup>15</sup> = 32K) のアドレスが40μs毎に (ピッチゼロの場合) 順次進行せねばなりません。

一方アドレスカウンタの出力は13ビットですから、残り2ビットをカウンタに同期して生成せねばなりません。アドレスカウンタはフリーランニング方式ではないので、8Kbyte目でオール1となり停止してしまいます。カウンタのラン時間を拡張して32Kbyteのメモリにアクセス出来るようにするには、カウンタの最上位ビットが15ビット目となるよう各ビットを2桁シフトアップする必要があります。(代りにA13, A14アドレスを最下位ビットへ移行させる。)

TR-626ではビット0、ビット1をゲートアレイ IC13で生成し、CH1のA13, A14として音源ROMへ加えます。またIC13はビット1と同一周期のクロックをXCKとしてアドレスカウンタのCH1へ加えます (Fig 4)。このクロックによるアドレスカウンタのADR0出力はFig 7に示す如く160μs毎に変化し (ピッチゼロの場合)、これはLSBが40μs毎に変化するアドレス構成の3ビット目に相当します。

**注.** IC14のADR0出力は直接ROMへ加えられず、IC13を経由しています。これはTable 2のA0欄を見ると判る如く、チャンネル4-7では“0”または“1”に固定する必要があります。IC13は、チャンネルに応じてA0の状態を変えてからROMへ送り出します。

Fig. 7 CCY ADDRESS

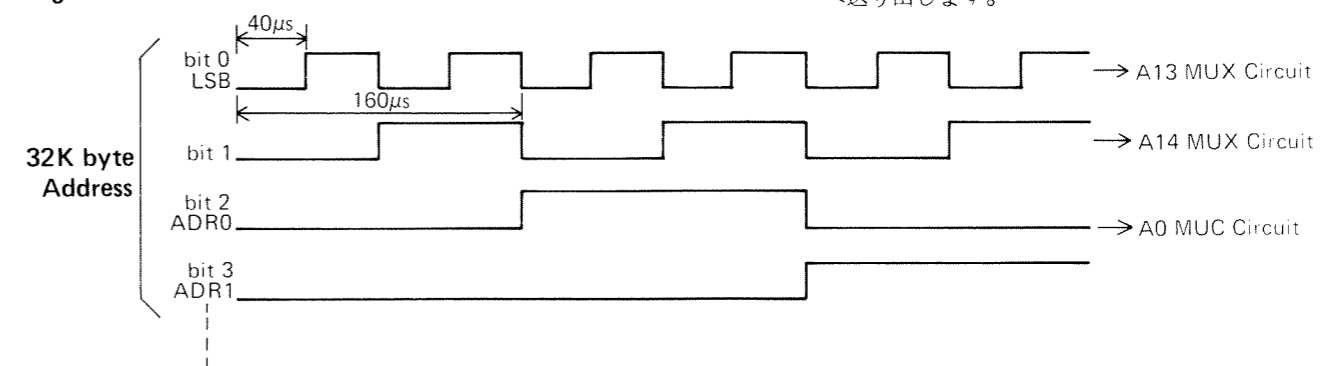

### 3. FSK MOD/DEMODO BU3904S (IC10, Main Board)

BU3904S is a Roland custom IC designed to function as an FSK modulator/demodulator. The function mode of IC10 is generally determined by a command applied to D0-D3. With the TR-626 only D2 is changed its status while D0, D1 and D3 are held at fixed level.

MOD = D2 "L" DEMOD = D2 "H"

#### During Modulation

Modulation is controlled by P0 input: FSK0 outputs 1.3 kHz at "L" P0 and 2.1kHz at "H" P0.

#### During Demodulation

RCK output changes the level according to signal frequency on FSKI. IC9 selects the RCK pulse instead of the tempo clock, as desired, and sends it to P20/TIN of the CPU.

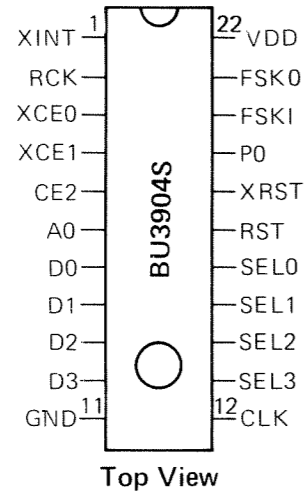

Table 3 BU3904S FSK MOD/DEMODO

Name	Pin No.	I/O	Description
XINT	1	O	demodulation output (for interrupt), active low (NC)
RCK	2	O	demodulation clock output
XCE0	3	I	chip select, active low pulled down
XCE1	4	I	chip select, active low pulled down
CE2	5	I	chip select, active high
A0	6	I	data/command select "L" = command "H" = data pulled down
D0	7	I	data/command input L = MOD H = DEMOD pulled down pulled down pulled up
D1	8	I	
D2	9	I	
D3	10	I	
GND	11	-	GND
CLK	12	I	clock input 1MHz
SEL3	13	I	clock select (1-8,10,12,14,16MHz) pulled up pulled up pulled up pulled up
SEL2	14	I	
SEL1	15	I	
SEL0	16	I	
RST	17	I	reset, active high pulled down
XRST	18	I	reset, active low
P0	19	I	modulation control
FSKI	20	I	FSK signal input
FSKO	21	O	FSK signal output
V <sub>DD</sub>	22	-	power supply +5V

### 3.FSK変調・復調 BU3904SCIC10, メインボード)

BU3904Sは、FSK変調/復調用のカスタムICです。モード設定はD0~D3へ加えられるコマンドによって決まりますが、TR-626ではD0, D1, D3は固定とし、D2のみでコントロールします。

D2 "L" = 変調、D2 "H" = 復調

#### 変調時

変調制御はP0入力によって行われFSK0の出力信号はP0 "L" で1.3 KHz、"H" で2.1 KHzとなります。

#### 復調時

復調時には、FSKIに入力されるFSK信号によって、RCKの出力が変化します。復調時IC9はテンポクロックの代わりにこのRCKパルスをCPUのP20/TINへ加えます。

### 4. Memory Card Interface μPD65006GF-198 (IC1, Main Board)

The gate array contains 3-state buffers. Inserting the memory card into the card socket pulls CST high. When CST is high:

A0-A14 are transferred to CA0-CAE, respectively, XWR (low active) to CWE (low active), XRD (low active) to COE (low active) and XCS (low active) to CCE (high active).

High CCE activates bidirectional buffers DB0-DB7 and CD0-CD7. Read/write is selected by XRD. Two chip select inputs are provided: XCS (low active) and CS (high active), but XCS only used in the TR-626. RCS (high active) and XRCS (low active) are used to detect the status of memory card. When they are made active, inputs are transferred:

XWP input (set position of protect switch - L = protect) to DB0

CST input to DB1

BATT input to DB2 (unused in the TR-626)

Switching to external bank enables the CPU to use RCS to read the status of the memory card.

During access to external memory (banks 2 and 3) the CPU checks the card at constant intervals.

### 4.メモリーカード・インターフェイス μPD65006GF-198 (IC1, メインボード)

本ゲートアレイには3ステートのバッファが内蔵されています。

メモリーカードがソケットに挿入されると、CST端子が"H"となります。

CSTが"H"になると

A0 ~ A14がCA0 ~ CAEへ  
XWR (ローアクティブ)がCWE (ローアクティブ)へ  
XRD (ローアクティブ)がCOE (ローアクティブ)へ  
XCS (ローアクティブ)がCCE (ハイアクティブ)へ  
それぞれ出力されます。

CCEが"H"になると双方向性のバッファDB0~DB7およびCD0~CD7がアクティブとなり、XRDの状態に応じてメモリーカードへの書き込みまたは読み出しが可能となります。なお、チップセレクト入力には、XCS (ローアクティブ)とCS (ハイアクティブ)の2つがありますが、TR-626ではXCSのみ使用しています。

RCS (ハイアクティブ)およびXRCS (ローアクティブ)はメモリーカードの状態検出用端子です。これらの端子がアクティブになると、

DB0にXWP (プロテクトSWの状態... "L" プロテクト)

DB1にCST

DB2にBATT (TR-626では使用していない)

の入力がそれぞれ出力されます。

メモリが外部バンクに切替えられると、CPUはRCSを使ってメモリーカードの状態を読み込みチェックします。また外部メモリ (バンク2, 3) がアクセスされている時は、一定の間隔でカードの状態をくり返しチェックします。

Fig. 8 Memory Card Access Timing Chart

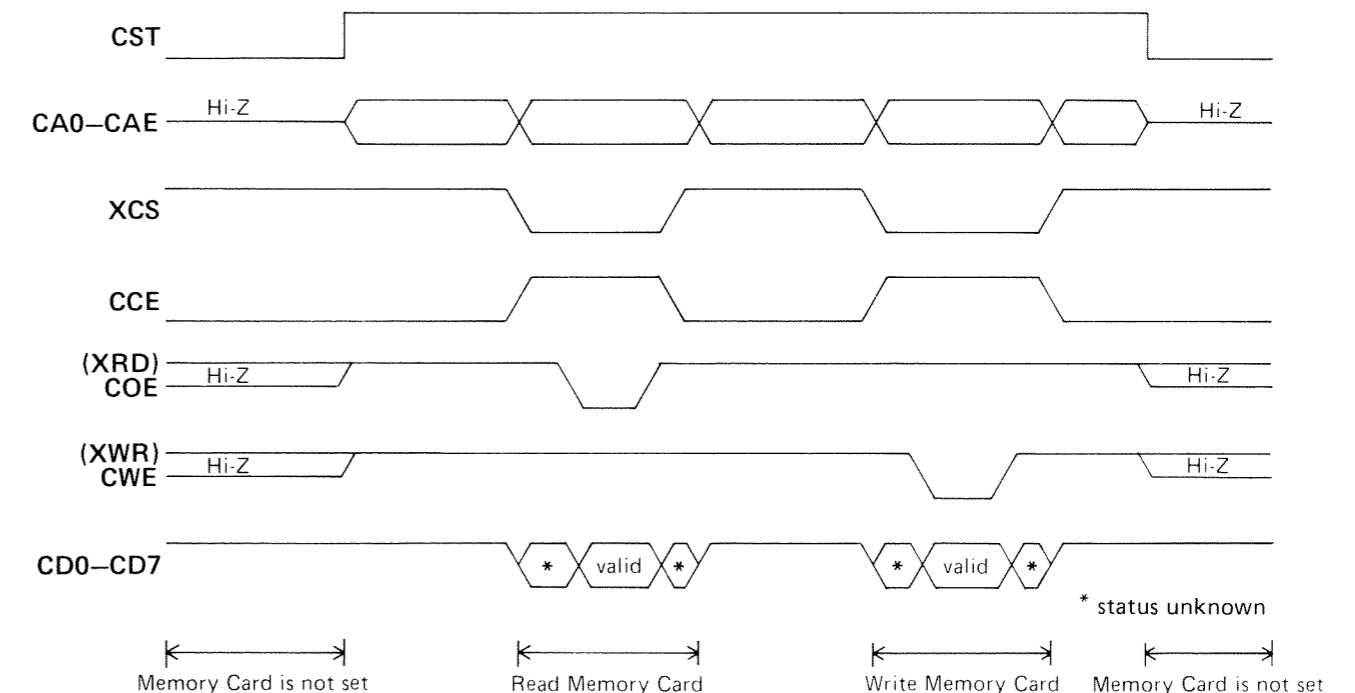



1 2 3 4 5 6 7 8 9 10 11 12 13 14 15 16 17 18 19 20 21 22 23 24 25 26 27 28 29 30 31 32 33 34 35 36 37 38 39

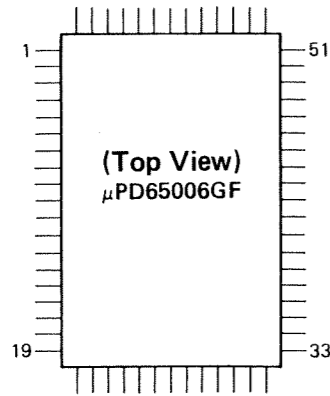

Gate Array μPD65006GF-198 IC1 Memory Card Interface

Name	Pin No.	I/O	Description
A0	40	I	address bus
1	42	I	
2	44	I	
3	46	I	
4	48	I	
5	50	I	
6	52	I	
7	53	I	
8	51	I	
9	49	I	
10	43	I	
11	47	I	
12	55	I	
13	29	I	
14	28	I	
RCS	31	I	read card status, active high
XRCS	32	I	read card status, active low (not used) pulled down
CS	57	I	chip select, active high
XCS	30	I	chip select, active low
XRD	45	I	read (or output enable), active low
XWR	54	I	write enable, active low
CST	2	I	CST (memory card)
XWP	15	I	WPOUT (memory card)
BATT	56	I	battery voltage detector
			memory card status pulled down
CA0	25	O	address bus
1	60	O	
2	61	O	
3	62	O	
4	63	O	
5	64	O	
6	24	O	
7	23	O	
8	22	O	
9	21	O	
A	20	O	
B	19	O	
C	18	O	
D	17	O	
E	16	O	
CCE	13	O	chip enable, active high
COE	12	O	output enable, active low
CWE	14	O	write enable, active low
DB0	41	I/O	data bus (to CPU)
1	39	I/O	
2	37	I/O	
3	35	I/O	
4	33	I/O	
5	34	I/O	
6	36	I/O	
7	38	I/O	
CD0	10	I/O	data bus (to memory card)
1	9	I/O	
2	8	I/O	
3	7	I/O	
4	6	I/O	
5	5	I/O	
6	4	I/O	
7	3	I/O	
GND	11	-	GND
GND	26	-	
GND	58	-	
V <sub>DD</sub>	27	-	
V <sub>DD</sub>	59	-	
(NC)	1	-	(NC)

Memory Card M-128D (RAM 16K bytes)

Name	Pin No.	I/O	Description
Vcc	1	-	power supply, +5V
A0	2	I	address bus
1	3	I	
2	4	I	
3	5	I	
4	6	I	
5	7	I	
6	8	I	
7	9	I	
8	10	I	
9	11	I	
10	12	I	
11	13	I	
12	14	I	
13	15	I	
(NC)	16	-	(NC)
(NC)	17	-	
(NC)	18	-	
(NC)	19	-	
WPOUT	20	O	write protect switch status "L" = protect
WE	21	I	write enable active low
CE	22	I	chip enable active high
OE	23	I	output enable, active low
DO	24	I/O	data bus
1	25	I/O	
2	26	I/O	
3	27	I/O	
4	28	I/O	
5	29	I/O	
6	30	I/O	
7	31	I/O	
GND	32	-	GND
V <sub>BB</sub>	33	O	back-up battery voltage output
CST	34	O	card status output, "H" = card enable

NOTES:

Pin 16 to which M-128D has no connection. However, the pin on the socket connects to CAE of IC1 and is pulled low. This provision is to make it possible to use another memory card M-256D for which pin 16 serves as A14. Pin 33 The TR-626 does not check the voltage (VBB) on this pin.

CAUTION

Pin 33 must be left open. Otherwise, the life expectancy of the battery in the memory card will be shortened.

注. 16番ピンはM-128Dでは(NC)ですが、M-256DではA14となります。そのためTR-626では、16番ピンをゲートアレイμPD65006GF-198に接続し、16番ピンが常に“L”になるようにしています。33番ピンV<sub>BB</sub>はTR-626では使用していません。(PCB上のコネクタの33番ピンは(NC)になっています。)

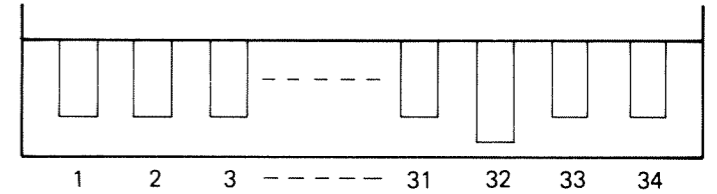

LCD Drive Board Assy 22585104  
View from Foil side

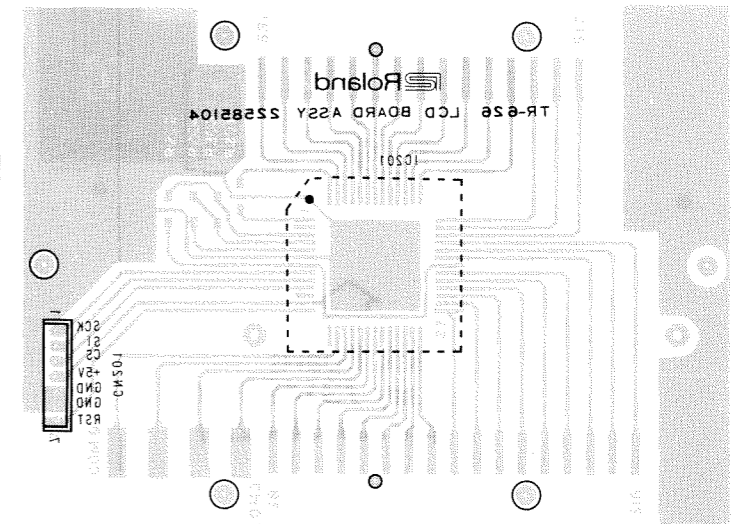

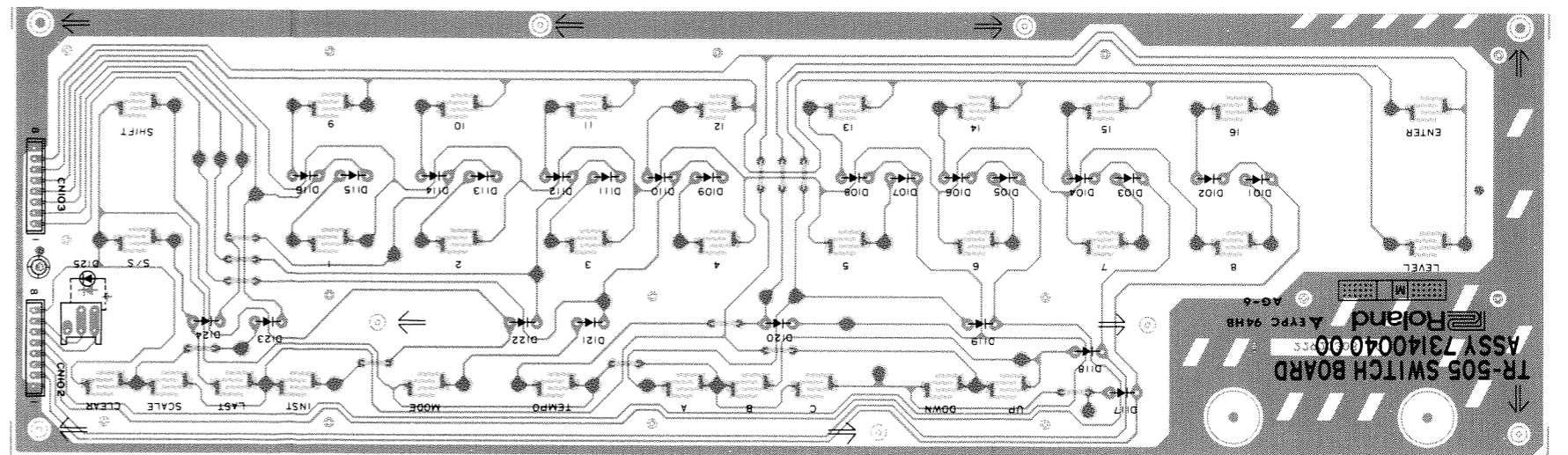

Switch Board Assy 7314004000  
(pcb 22920308)

Identical to switch board for TR-505  
TR-505のスイッチ基板と同一

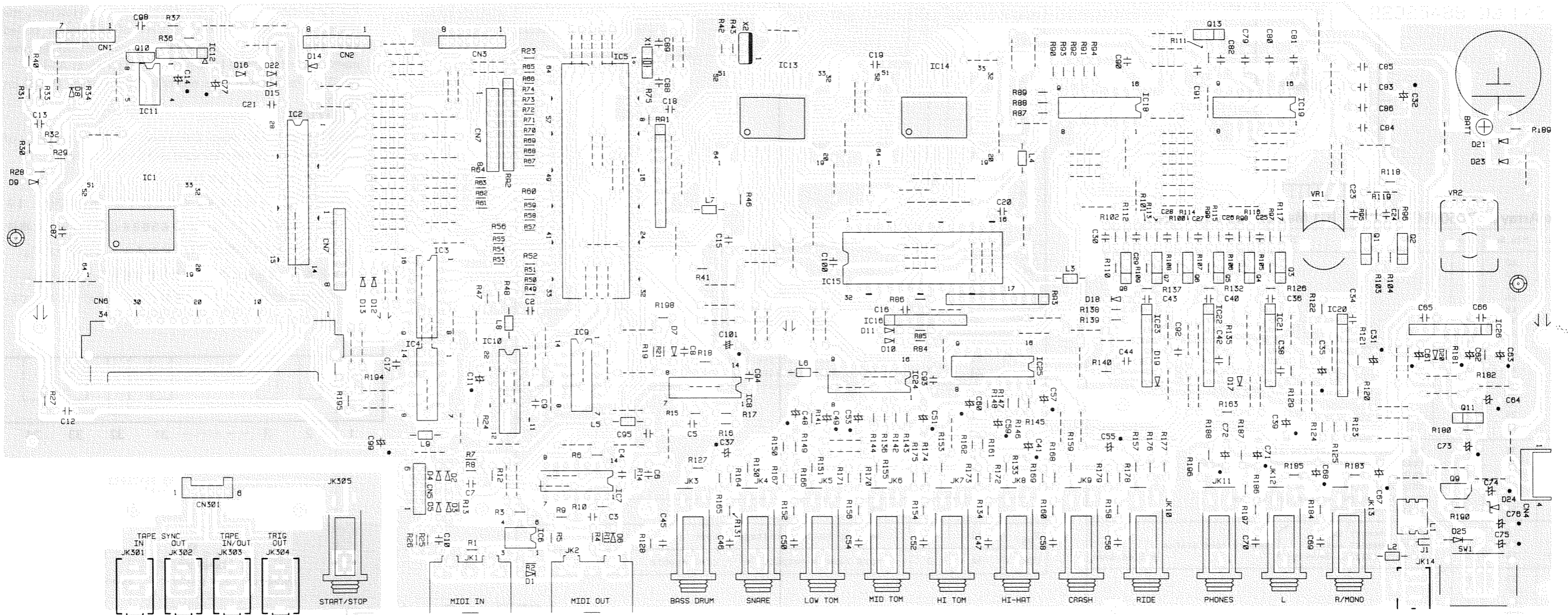

1 2 3 4 5 6 7 8 9 10 11 12 13 14 15 16 17 18 19 20 21 22 23 24 25 26 27 28 29 30 31 32 33 34 35 36 37 38 39 40 41 42



  
**Jack Board**  
**Assy 7314905000**  
 (pcb 22925488 2/2)

**Main board and Jack board**  
 Supplied in a set with Main  
 board made representative.

メインボードとジャックボードは  
 セットで供給されます。  
 (メインボードが代表となります)

**Main Board**  
**Assy 7314906000**  
 (pcb 22925488 1/2)

**ADVARSEL!**

Lithiumbatteri. Eksplosionsfare.  
 Udskiftning må kun foretages af en sagkyndig,  
 og som beskrevet i servicemanual.

Lithium batteri må kun udskiftes med samme type  
 og fabrikat

**VARNING!**

Lithiumbatteri. Explosionsrisk.  
 Får endast bytas av behörig servicetekniker.  
 Se instruktioner i servicemanualen.

Lithium batteri for endast ersattes med samme type  
 och fabrikat

**ADVARSEL!**

Lithiumbatteri. Fare for eksplotion.  
 Må bare skiftes af kvalifisert tekniker som  
 beskrevet i servicemanualen.

Lithium batteri må kun utskiftes med samme type  
 og fabrikat

**VAROITUS!**

Lithiumparisto. Rajhdysvaara.  
 Pariston saa vaihtaa ainoastaan  
 alan ammottimies.

Kun vaihat lithium pariston KAYTA saman valmista-  
 jan samaa tyyppiä

# CIRCUIT DIAGRAM

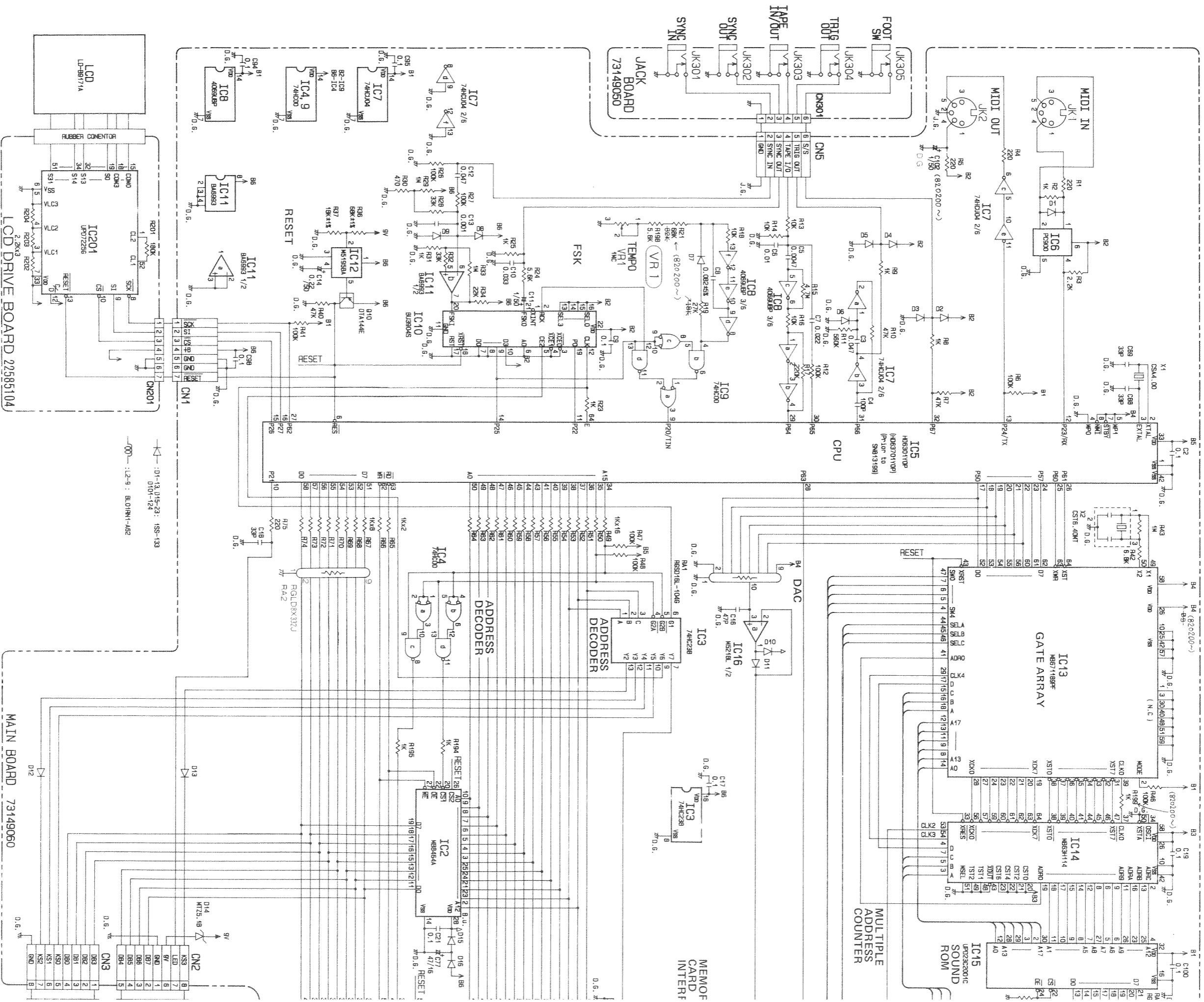

1 2 3 4 5 6 7 8 9 10 11 12 13 14 15 16 17 18 19 20 21 22 23 24 25 26 27

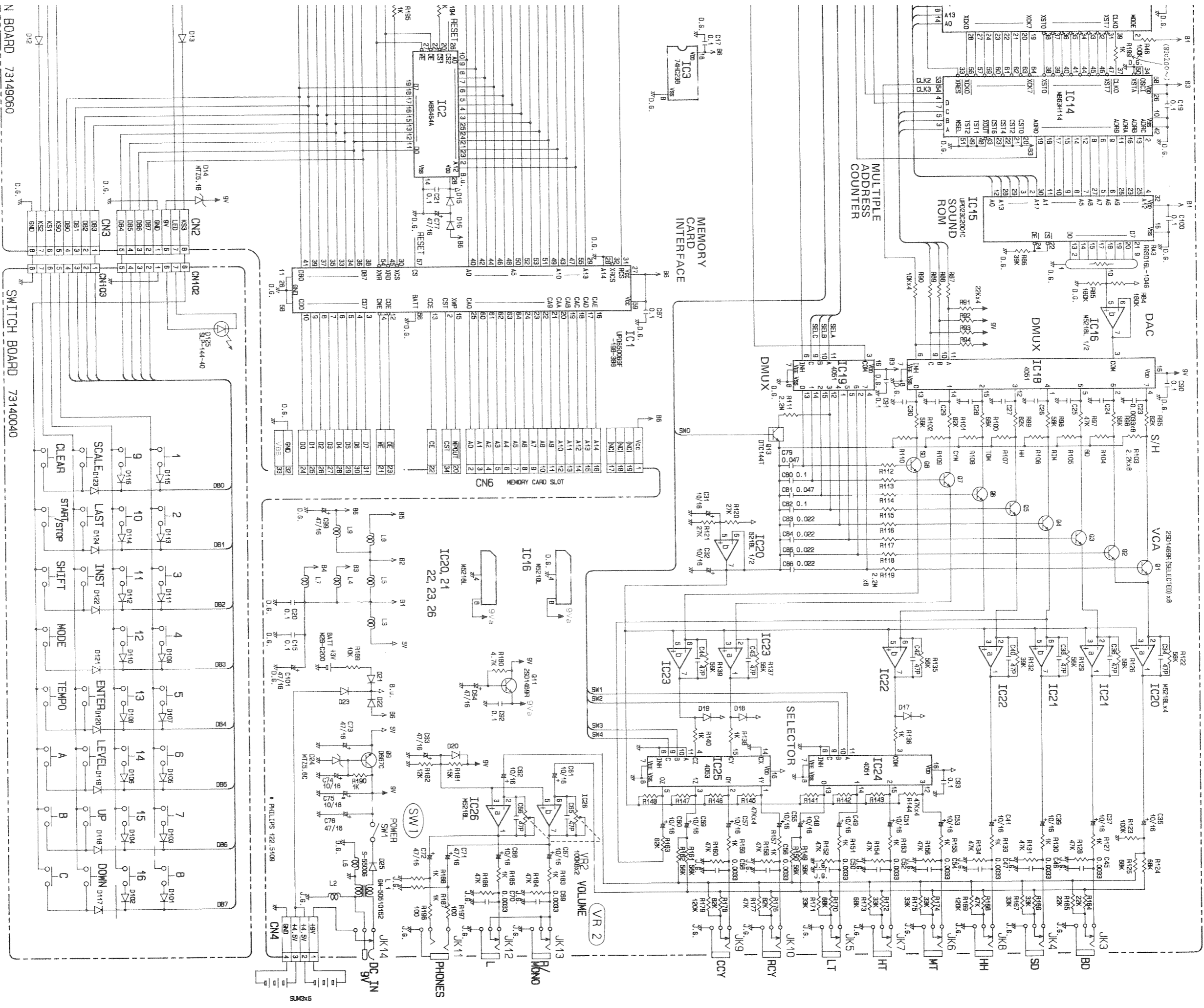

N BOARD 73149060

SWITCH BOARD 73140040

# TROUBLESHOOTING LOGIC TREE トラブルシューティング例

ex.1)

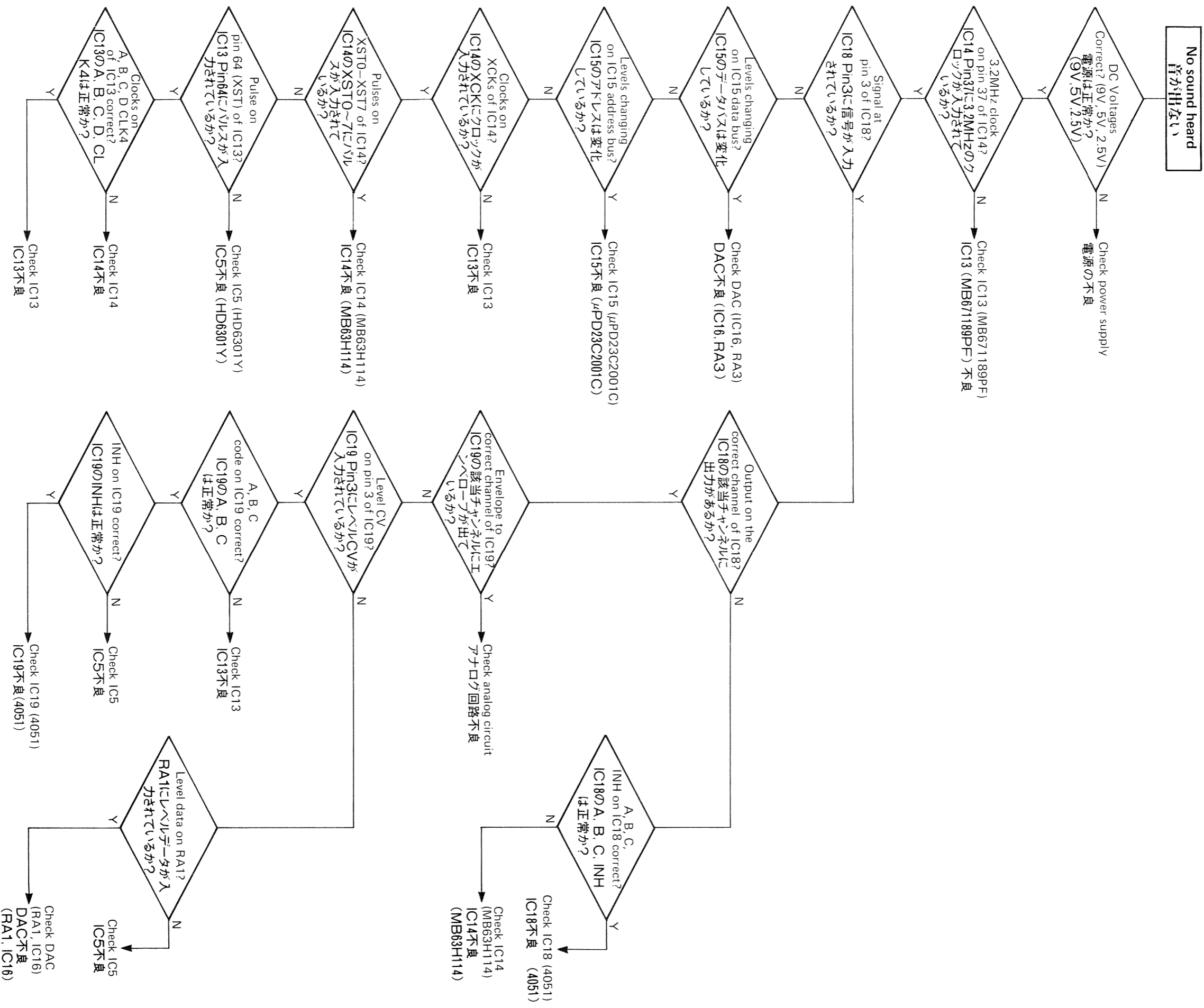

ex.2)

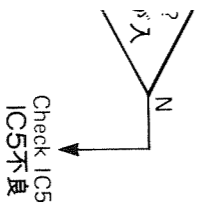
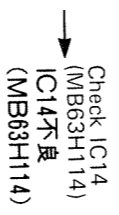
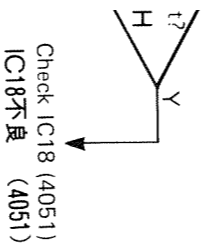
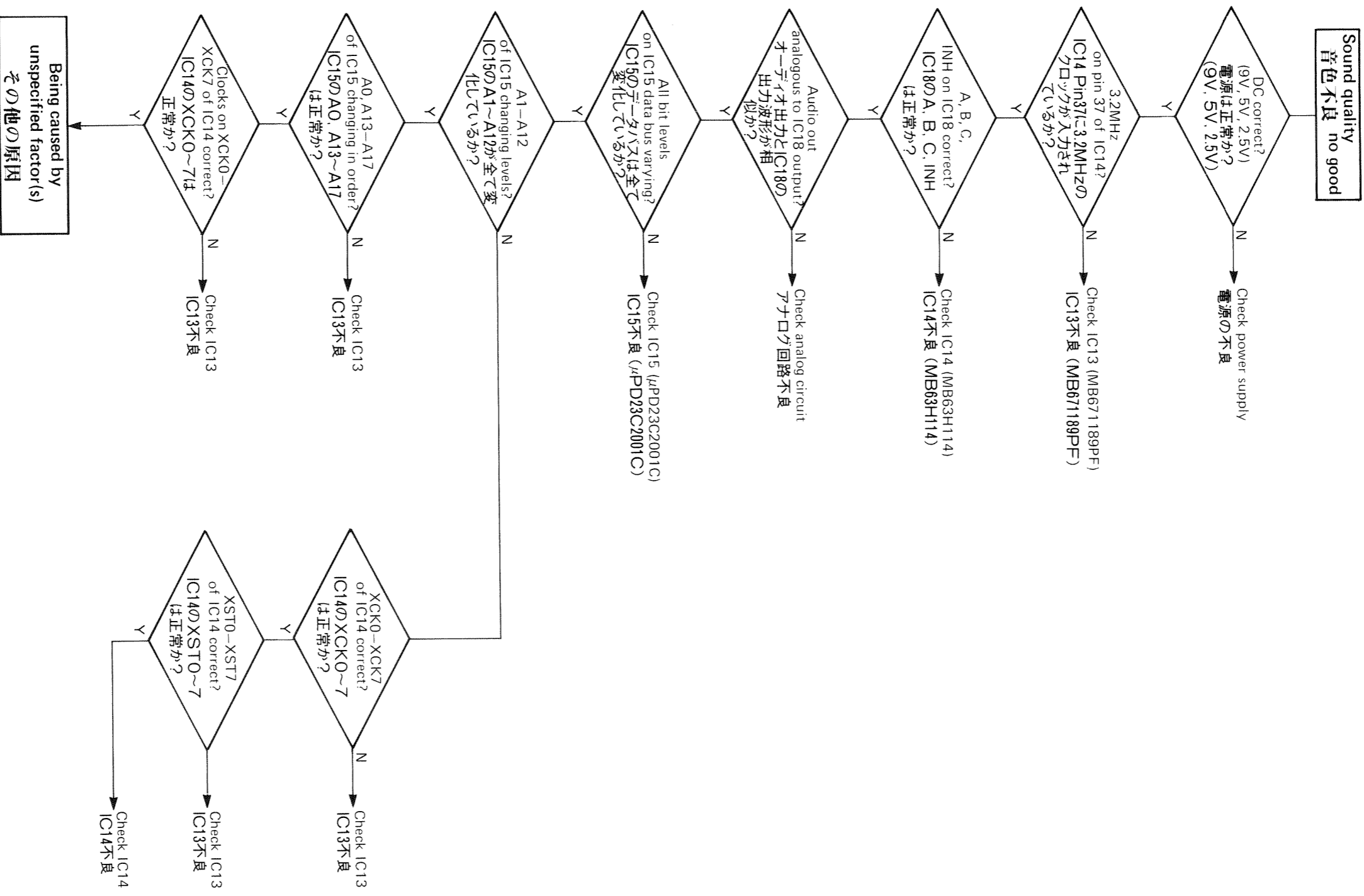

IC DATA

Gate Array MB63H114

Name	Pin No.	I/O	Description		
CST0	20	I	continue start	counter 0	pulled up
	21	I	continue start	counter 2	pulled up
	22	I	continue start	counter 4	pulled up
	23	I	continue start	counter 6	pulled up
XSTA	50	I	XST0 - XST7 enable	active low	pulled down
XST0	38	I	counter start	counter 0	active low
1	39	I	counter start	counter 1	active low
2	40	I	counter start	counter 2	active low
3	41	I	counter start	counter 3	active low
4	44	I	counter start	counter 4	active low
5	45	I	counter start	counter 5	active low
6	46	I	counter start	counter 6	active low
7	47	I	counter start	counter 7	active low
XCK0	56	I	counter clock input	counter 0	
1	57	I	counter clock input	counter 1	
2	59	I	counter clock input	counter 2	
3	60	I	counter clock input	counter 3	
4	61	I	counter clock input	counter 4	
5	62	I	counter clock input	counter 5	
6	63	I	counter clock input	counter 6	
7	64	I	counter clock input	counter 7	
XOUT	43	I	ADRO - ADRC out enable	active low	pulled down
ADRO	19	0	ROM address		
1	18	0			
2	17	0			
3	15	0			
4	14	0			
5	12	0			
6	8	0			
7	6	0			
8	9	0			
9	11	0			
A	16	0			
B	13	0			
C	2	0			
A	3	0	timing clock	200kHz	MUX DMUX channel select
B	5	0	timing clock	100kHz	
C	7	0	timing clock	50kHz	
D	4	0	timing clock	25kHz	
INH0	1	0	DMUX inhibit		(NC)
OSCI	34	I	X'tal terminals for internal clock generator		
SC00	35	0	internal clock generator		
SC01	36	0	internal clock generator output		
CLK0	37	I	master clock input, 3.2MHz		
CLK1	52	0	system clock	400kHz	(NC)
2	53	0	system clock	400kHz	DMUX inhibit
3	54	0	system clock	400kHz	timing clock for MB671189
4	55	0	system clock	400kHz	(NC)
XRES	33	I	reset, active low		
MSEL	51	I	counter 12/13 bit select		
TST1	48	I	IC test		
TST2	49	I	IC test		
Vss	10	-	GND		
Vss	42	-	GND		
V <sub>DD</sub>	26	-	power supply, +5V		
V <sub>DD</sub>	58	-	power supply, +5V		
GAT0	32	0	counter gate output, "H" = counter running		
1	31	0			
2	30	0			
3	29	0			
4	28	0			
5	27	0			
6	25	0			
7	24	0			

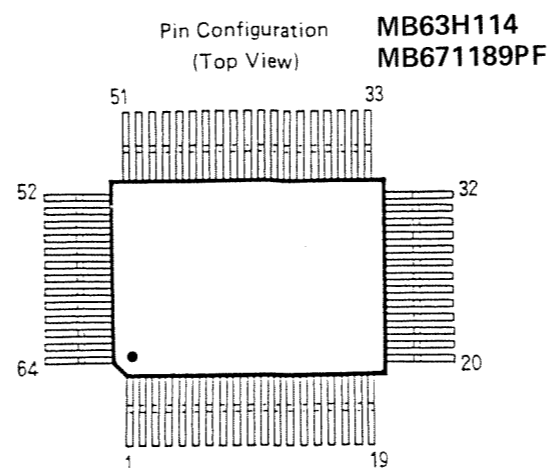

CHECKING IC14 MB63H114

The gate out pins GAT0 - GAT7 of IC14 will indicate the status of mated counter.

While a counter is running, its GAT pin stays high.

ゲートアレイ(IC14,MB63H114)良否判定のヒント

故障診断の際、ゲートアレイの良否を以下の方法で判定する事が出来ます。ゲートアレイのゲート(GAT0-GAT7)は対応したカウンタが走っている間、ハイとなります。

Gate Array MB671189PF

Name	Pin No.	I/O	Description		
XWR	63	I	data latch pulse (for sound select)		active Low
XST	64	I	data latch pulse (for pitch) & counter start		active Low
D0	52	I	date input		
1	53	I			
2	54	I			
3	55	I			
4	56	I			
5	60	I			
6	61	I			
7	62	I			
CLK4	29	I	timing clock		to ROM address decoder
A	18	I	timing clock	MUX channel select	
B	16	I	timing clock		
C	15	I	timing clock		
D	17	I	timing clock		
ADRO	41	I	multiple address counter bit 0		
XCK0	38	0	counter start pulse	counter 0	
1	37	0	counter start pulse	counter 1	
2	36	0	counter start pulse	counter 2	
3	35	0	counter start pulse	counter 3	
4	34	0	counter start pulse	counter 4	
5	33	0	counter start pulse	counter 5	
6	32	0	counter start pulse	counter 6	
7	31	0	counter start pulse	counter 7	
XCK0	28	0	counter clock	counter 0	
1	27	0	counter clock	counter 1	
2	24	0	counter clock	counter 2	
3	23	0	counter clock	counter 3	
4	22	0	counter clock	counter 4	
5	21	0	counter clock	counter 5	
6	20	0	counter clock	counter 6	
7	19	0	counter clock	counter 7	
A0	14	0	ROM address		
A13	8	0			
14	9	0			
15	11	0			
16	13	0			
SEL A	44	0	level CV channel select		
B	45	0			
C	46	0			
SW0	47	0	sound select	"H" = Closed Hi-Hat	"L" = Open Hi-Hat
1	7	0	sound select	"H" = L.TOM, M.TOM	"L" = H.TOM, Congas
2	6	0	sound select	"H" = M.TOM, H.TOM	"L" = L.TOM, Congas
3	5	0	sound select	"H" = Ride, Cup	"L" = Crash, China
4	4	0	sound select	"H" = Timbales	"L" = Snare Drum 1,2
MODE	2	I	mode select		"H" = variable pitch "L" = fixed pitch pulled up
XRST	43	I	reset, active low		
X1	49	I	X'tal terminals for internal clock generator, 6.4MHz		
X2	50	0			
CLK0	39	0			
Vss	10	-	GND		
Vss	25	-			
Vss	42	-			
Vss	57	-			
V <sub>DD</sub>	26	-			
V <sub>DD</sub>	58	-	power supply, +5V		
(NC)	1	-	(NC)		
(NC)	3	-			
(NC)	30	-			
(NC)	40	-			
(NC)	48	-			
(NC)	51	-			
(NC)	48	-			
(NC)	51	-			
(NC)	59	-			

CPU HD6301Y0A99P  
HD63701Y0P

Pin Configuration  
(Top View)

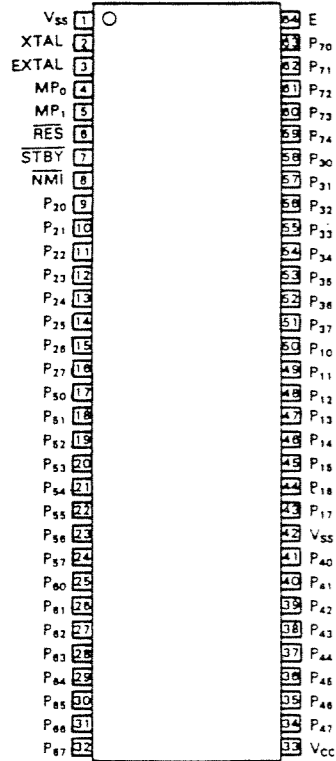

PIN NO.	PORT NAME	DESCRIPTION
1	Vss	GND
2	XTAL	terminal, Xtal
3	EXTAL	terminal, Xtal
4	MP0	input, Mode Setting, pulled down
5	MP1	input, Mode Setting, pulled up +5V
6	RES	input, Reset (active low)
7	STBY	unused, pulled up +5V (active low)
8	NMI	unused, pulled up +5V (active low)
9	P20	input, TEMPO CLOCK
10	P21	output, LED
11	P22	output, FSK P0
12	P23	input, MIDI IN
13	P24	output, MIDI OUT
14	P25	output, FSK D2
15	P26	output, LCD CS
16	P27	output, LCD SI
17	P50	output, Sound Select Sound Select Pitch Data Level Data
18	P51	
19	P52	
20	P53	
21	P54	
22	P55	
23	P56	
24	P57	
25	P60	output, XWR
26	P61	output, XST
27	P62	output, LCD SCK
28	P63	output, Level CV DMUX, INH
29	P64	input, LOAD (TAPE)
30	P65	output, SAVE (TAPE)
31	P66	output, TRIG OUT
32	P67	input, START/STOP
33	Vcc	+5V power supply
34	P47	A15
35	P46	A14
36	P45	A13
37	P44	A12
38	P43	A11
39	P42	A10
40	P41	A9
41	P40	A8
42	Vss	GND
43	P17	A7
44	P16	A6
45	P15	A5
46	P14	A4
47	P13	A3
48	P12	A2
49	P11	A1
50	P10	A0
51	P37	D7
52	P36	D6
53	P35	D5
54	P34	D4
55	P33	D3
56	P32	D2
57	P31	D1
58	P30	D0
59	P74	unused
60	P73	unused
61	P72	unused
62	P71	output, WE
63	P70	output, RD
64	E	output, system clock, 1MHz

LCD LDB9171A

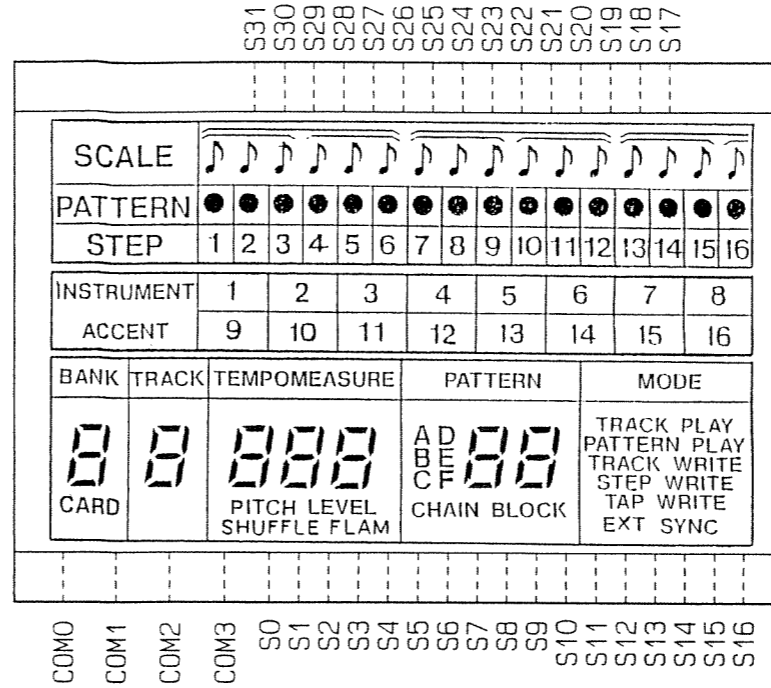

	COM 0	COM 1	COM 2	COM 3
S 0	7 seg #1 a	f	g	e
S 1	CARD	b	c	d
S 2	7 seg #2 a	f	g	e
S 3	TEMPO	b	c	d
S 4	7 seg #3 a	f	g	e
S 5	MEASURE	b	c	d
S 6	7 seg #4 a	f	g	e
S 7	PITCH	b	c	d
S 8	FLAM	---	---	SHUFFLE
S 9	7 seg #5 a	f	g	e
S10	LEVEL	b	c	d
S11	CHAIN	A	B	C
S12	PATTERN	D	E	F
S13	7 seg #6 a	f	g	e
S14	BLOCK	b	c	d
S15	7 seg #7 a	f	g	e
S16	PATTERN PLAY	b	c	d
S17	TRACK WRITE	STEP WRITE	TAP WRITE	EXT SYNC
S18	TRACK PLAY	(INST) 14	(INST) 15	(INST) 16
S19	(INST) 5	(INST) 6	(INST) 7	(INST) 8
S20	(STEP) 9	(STEP) 11	(STEP) 13	(STEP) 15
S21	(STEP) 10	(STEP) 12	(STEP) 14	(STEP) 16
S22	(DOT) 9	(DOT) 11	(DOT) 13	(DOT) 15
S23	(DOT) 10	(DOT) 12	(DOT) 14	(DOT) 16
S24				
S25	(DOT) 7	(DOT) 5	(DOT) 3	(DOT) 1
S26	(DOT) 8	(DOT) 6	(DOT) 4	(DOT) 2
S27	(STEP) 7	(STEP) 5	(STEP) 3	(STEP) 1
S28	(STEP) 8	(STEP) 6	(STEP) 4	(STEP) 2
S29	(INST) 4	(INST) 3	(INST) 2	(INST) 1
S30	(INST) 12	(INST) 11	(INST) 10	(INST) 9
S31	(INST) 13		ACCENT	INSTRUMENT

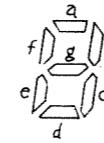

7 seg # \* Arrangement  
7 seg #1 : leftmost  
7 seg #7 : rightmost

7segパターン配列  
7seg #1.....左端  
7seg #7.....右端



# MIDI IMPLEMENTATION

[ RHYTHM MACHINE ]  
MODEL TR-626 MIDI Implementation Chart Date : Jul.23.1987  
Version : 1.0

Function ...	Transmitted	Recognized	Remarks
Basic Default	1-16	1-16	memorized
Channel Changed	1-16	1-16	(non-volatile)
Mode Default	Mode 3	Mode 1	memorized
Messages Altered	*****	OMNI ON/OFF	(non-volatile)
Note Number : True voice	25-99 *1 *****	25-99 *1	assignable to each voice
Velocity Note ON	o 9n v=18-127	o 9b v=1-127	n=Inst CH #2 b=Basic CH
Note OFF	x 9n v=0	x	
After Touch	Key's Ch's x	x	
Pitch Bender	x	x	
Control Change	x	x	
Prog Change : True #	x *****	x	
System Exclusive	o	o	
System Song Pos	o	o SYNC = MIDI	
Song Sel	o	o SYNC = MIDI	
Common Tune	x	x	
System Clock	o	o SYNC = MIDI	
Real Time Commands	o	o SYNC = MIDI	
Aux Local ON/OFF	x	x	
All Notes OFF	x	x	
Mes-Active Sense	x	x	
sages:Reset	x	x	
Notes	*1 Can be changed by panel operation. *2 Transmit channel number of each voice can be changed to 1 to 16 by panel operation.		

Mode 1 : OMNI ON, POLY    Mode 2 : OMNI ON, MONO    o : Yes  
Mode 3 : OMNI OFF, POLY    Mode 4 : OMNI OFF, MONO    x : No

Transmit channel for each voice can be set to any of 1 to 16 by panel operation.  
Note number of each voice can be assigned to one of 25 to 99. The above settings can be made by panel operation and are non-volatile.  
The accent value (-3 to +3) written in a pattern determines the note velocity, overriding the volume level set internally.

Accent	Velocity
-3	12H
-2	19H
-1	23H
0	30H
+1	42H
+2	5BH
+3	7FH

■ System exclusive

Status  
-----  
FOH :System Exclusive  
F7H :EOX(End of Exclusive)

Refer to 3.EXCLUSIVE COMMUNICATIONS.

■ System common

Song Position Pointer

Status	Second	Third
F2H	11H	hhH

ll = Least significant :00H - 7FH (0 - 127)  
hh = Most significant :00H - 7FH (0 - 127)

Sent whenever MEASURE FORWARD or MEASURE BACK is pressed, or a measure number is specified.

Song Select

Status	Second
F3H	ssH

ss = song select :00H - 05H (0 - 5)

Sent whenever the track is set to new track from the panel. One each of the track numbers 1 to 6 corresponds to the song selects 0 to 5 in that order.

■ System Real Time

Timing Clock

Status  
-----  
F8H

Sent even if the rythm is not running.

Start

Status  
-----  
FAH

Sent upon pressing START for playing.

Continue

Status  
-----  
FBH

Sent upon pressing CONTINUE START for re-running the rhythm.

Stop

Status  
-----  
FCH

RHYTHM MACHINE  
MODEL TR-626 MIDI IMPLEMENTATION Version 1.0 Jul.24.1987

1. TRANSMITTED DATA

■ Note event

Note off

Status	Second	Third
9nH	kkH	00H

n = Transmit channel : 0H - FH (1 - 16)  
kk = Note number :19H - 63H (25 - 99)

Note on

Status	Second	Third
9nH	kkH	vvH

kk = Note number :19H - 63H (25 - 99)  
vv = Velocity :12H - 7FH (18 - 127)  
Determined by Accent value: -3 to +3

Sent whenever the rhythm is stopped.

When Sync mode is set at MIDI, the TR-626 sends (software through) the real time messages received from MIDI IN.

2. RECOGNIZED RECEIVE DATA

■ Channel mode message

OMNI OFF

Status	Second	Third
BbH	7CH	00H

OMNI ON

Status	Second	Third
BbH	7DH	00H

b = Basic channel : 0H - FH (1 - 16)

■ Note event

Note on

Status	Second	Third
9bH	kkH	vvH

b = Basic channel : 0H - FH (1 - 16)  
 kk = Note number : 19H - 63H (25 - 99)  
 vv = Velocity : 01H - 7FH (1 - 127)

The basic channel (receive channel) can be changed to 1-16 by panel operation. The Basic channel is non-volatile. Assignment of a Note number to a voice is common to MIDI IN and MIDI OUT. Assignment can be independent of the remaining voices. A MIDI IN note number will sound the voice to which it is assigned. The associated Velocity determines the volume of the voice, defeating the internal level setting.

■ System exclusive

Status	Description
FOH	:System Exclusive
F7H	:EOX(End of Exclusive)

Refer to 3.EXCLUSIVE COMMUNICATIONS.

■ System common

Recognized only when the TR-626 is in 'STOP' status in the Track Play mode.

Song Position Pointer

Status	Second	Third
F2H	llH	hhH

ll = Least significant : 00H - 7FH (0 - 127)  
 hh = Most significant : 00H - 7FH (0 - 127)

Song Select

Status	Second
F3H	ssH

ss = song select : 00H - 05H (0 - 5)  
 06H - 7FH ignored

One each of track numbers 1 to 6 corresponds to the song selects 0 to 5 in that order, regardless of memory bank being currently selected (internal or external memory card).

■ System Real Time

Recognized only when the Sync mode is set at MIDI.

Timing Clock

Status
FBH

When Sync mode is set at MIDI, the TR 626 keeps rhythm timing to this clock.

Start

Status
FAH

When Sync mode is set at MIDI, the TR-626 starts running on the Start message.

Continue

Status
FBH

When Sync mode is set at MIDI, the TR-626 starts continue play upon receiving this message.

Stop

Status
FCH

When Sync mode is set at MIDI, the TR-626 stops upon receipt of this message.

3.EXCLUSIVE COMMUNICATIONS

See the TR-626 Owner's Manual for send/receive procedures of the exclusive messages.

One way communication

■ Data set

When recognized, the following messages are stored internally.

Byte	Description
FOH	Exclusive status
41H	Roland - ID
0bH	Device - ID = MIDI Basic channel
1DH	Model - ID ( TR-626 )
12H	Command - ID ( DT1 )
aaH	Address (MSB)
bbH	Address (LSB)
ddH	Data dd = 00H - 7FH
:	:
ddH	Data
ssH	Sum ss:aaH + bbH + ddH + ... + d'H + ssH = 0
F7H	EOX ( End of Exclusive )

■ Address mapping of data

With the TR-626 the following data for memory bank 1 are available for send/receive of exclusive messages.

Pattern, track, and the level and pitch of each voice

Address	Description
aaH(MSB) bbH(LSB)	
00H 20H	data start address
	data
2DH 10H	data end address

**Roland®**  
**17059519**

