

SUZUKI

SJ413

SERVICE MANUAL

SUZUKI
Caring for Customers

99500-83010-01E

(英)

RELATED SERVICE MANUAL

| SERVICE MANUAL RELATED TO THIS MANUAL 99500-83010 | APPLICABILITY |
|--|--|
| SJ413 SUPPLEMENTARY SERVICE MANUAL 99501-83020-18E | Vehicles equipped with carburetor, oxygen sensor and catalyst |
| SJ413 SUPPLEMENTARY SERVICE MANUAL 99501-83020-25E | Vehicles equipped with catalyst (but not oxygen sensor) |
| SJ413 SUPPLEMENTARY SERVICE MANUAL 99501-83310 | Vehicles after body Nos. listed below. For European Market & Australian Market <input checked="" type="checkbox"/> JSAOSJ70000103001 <input checked="" type="checkbox"/> ~ <input checked="" type="checkbox"/> JSAOSJ70V00103001 <input checked="" type="checkbox"/> ~ <input checked="" type="checkbox"/> JSAOSJ50000190003 <input checked="" type="checkbox"/> ~ <input checked="" type="checkbox"/> JSAOSJ50V00150003 <input checked="" type="checkbox"/> ~ For Other Market SJ50-138999 ~ |
| SJ413 SUPPLEMENTARY SERVICE MANUAL 99501-83321 | Vehicles equipped with electronic fuel injection system |
| SJ413 SUPPLEMENTARY SERVICE MANUAL 99501-83330 | Vehicles after body Nos. listed below For European/Australian Markets <input checked="" type="checkbox"/> JSAOSJ70000400001 <input checked="" type="checkbox"/> <input checked="" type="checkbox"/> JSAOSJ70V00400001 <input checked="" type="checkbox"/> For Other Markets SJ70-400001 ~ |

For vehicles from the very beginning of the production up to body Nos. as listed in "FOREWARD", refer to SJ413 Service Manual 99500-83000.

| SERVICE MANUAL RELATED TO S/M 99500-83000 | APPLICABILITY |
|--|---|
| SJ413 SUPPLEMENTARY SERVICE MANUAL 99501-83001 | Vehicles equipped with oxygen sensor and catalyst |
| SJ413 SUPPLEMENTARY SERVICE MANUAL 99501-83010 | Vehicles equipped with catalyst (but not oxygen sensor) |

FOREWORD

This service manual is applicable to vehicle not equipped with catalytic converter.

This manual contains procedures for diagnosis, maintenance adjustments, service operations, replacement of components (Service) and for disassembly and assembly of major components.

The contents are classified into sections each of which is given a section number as indicated in the Table of Contents on next page. And on the first page of each individual section is an index of that section.

This manual should be kept in a handy place for ready reference of the service work. Strict observance of the so specified items will enable one to obtain the full performance of the vehicle.

When replacing parts or servicing by disassembling, it is recommended to use SUZUKI genuine parts, tools and service materials (lubricants, sealants, etc.) as specified in each description.

All information, illustrations and specifications contained in this literature are based on the latest product information available at the time of publication approval. The right is reserved to make changes at any time without notice. And used as the main subject of description is the vehicle of standard specifications among others. Therefore, note that illustrations and photos may differ from the vehicle being actually serviced.

IMPORTANT:

It is important to note that, during any vehicle maintenance procedures, replacement fasteners must have the same measurements as those removed.

Mismatched or incorrect fasteners can result in vehicle damage or malfunction, or possible personal injury.

Therefore, fasteners removed from the vehicle should be saved for re-use whenever possible.

Where the fasteners are not satisfactory for re-use, care should be taken to select a replacement that matches the original.

Additional information concerning this subject will be found in the section 0 (METRIC INFORMATION).

This service manual is applicable to vehicles of and after the following body number.

Effective body No.:

For European Market
 JSAOSJ70000102001
 JSAOSJ70V00102001
 JSAOSJ71000102001
 JSAOSJ50000170001
 JSAOSJ50V00140001
 JSAOSJ51000115001

For Other Market
SJ50 - 135001
SJ51 - 110001

SUZUKI MOTOR CORPORATION

TECHNICAL DEPARTMENT
AUTOMOBILE SERVICE DIVISION

TABLE OF CONTENTS

| | SECTION |
|---|-----------|
| GENERAL, SPECIAL TOOLS AND SERVICE MATERIALS | 0 |
| PERIODIC MAINTENANCE SERVICE | 1 |
| TROUBLE SHOOTING | 2 |
| ENGINE | 3 |
| FUEL SYSTEM (CARBURETOR, AIR CLEANER, FUEL PUMP AND FUEL FILTER) | 4 |
| EMISSION CONTROL SYSTEM | 5 |
| ENGINE COOLING SYSTEM | 6 |
| CAR HEATER | 7 |
| IGNITION SYSTEM | 8 |
| CRANKING SYSTEM | 9 |
| CHARGING SYSTEM | 10 |
| CLUTCH | 11 |
| GEAR SHIFTING CONTROL | 12 |
| TRANSMISSION | 13 |
| TRANSFER GEAR BOX | 14 |
| PROPELLER SHAFTS | 15 |
| DIFFERENTIAL | 16 |
| SUSPENSION | 17 |
| STEERING SYSTEM | 18 |
| BRAKES | 19 |
| BODY SERVICE | 20 |
| BODY ELECTRICAL EQUIPMENT | 21 |
| SERVICE DATA | 22 |
| | 23 |

GENERAL, SPECIAL TOOLS AND SERVICE MATERIALS

CONTENTS

| | | |
|------|--|------|
| 0-1. | LOCATIONS OF BODY NUMBER AND ENGINE NUMBER | 0-1 |
| 0-2. | STANDARD SHOP PRACTICES | 0-2 |
| 0-3. | SPECIAL TOOLS | 0-5 |
| 0-4. | REQUIRED SERVICE MATERIALS | 0-9 |
| 0-5. | METRIC INFORMATION | 0-12 |

0-1. LOCATIONS OF BODY NUMBER AND ENGINE NUMBER

The body number is punched on the chassis inside the tire housing on the right front side.

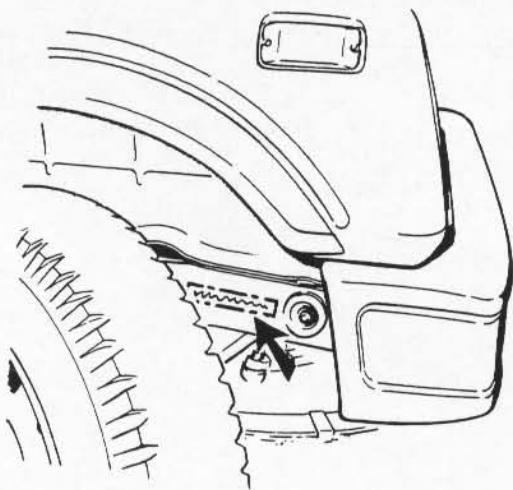

Fig. 0-1 Location of Body No.

The engine number is punched on the rear portion of the left-hand skirt part of cylinder block.

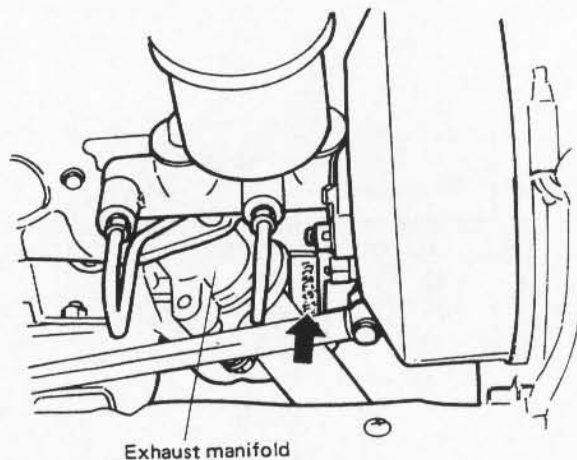

Fig. 0-2 Location of Engine No.

0-2. STANDARD SHOP PRACTICES

1. Protect painted surfaces of the body, and avoid staining or tearing seats. When working on fenders and seats, be sure to cover them up with sheets.
2. Disconnect negative terminal connection of the battery when working on any electrical part or component. This is necessary for avoiding electrical shocks and short-circuiting, and is very simple to accomplish: merely loosen wing nut on negative terminal and separate cable from terminal post.
3. In raising front or rear car end off the floor by jacking, be sure to put the jack against differential portion of axle housing.

NOTE:

Don't get on the car, get under it or service it in this state.

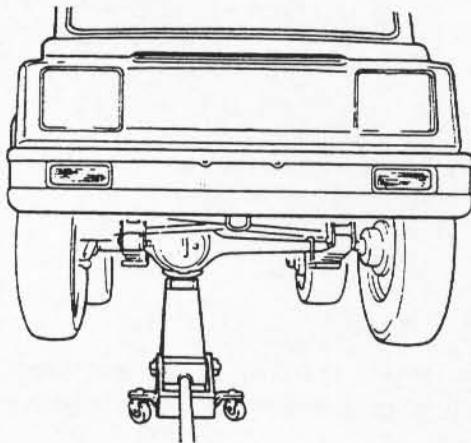

Fig. 0-3 Front Side

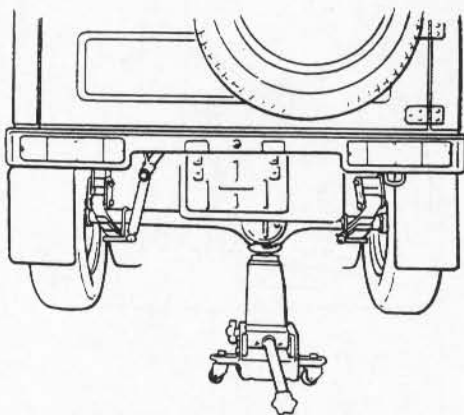

Fig. 0-4 Rear Side

4. To perform service with either front or rear car end jacked up, be sure to place safety stands under chassis frame so that body is securely supported. Refer to below figures for where to place safety stands. And then check to ensure that chassis frame does not slide on safety stands and the car is held stable for safety's sake.

WARNING:

Place chocks against both right and left wheels on the ground from both front and rear.

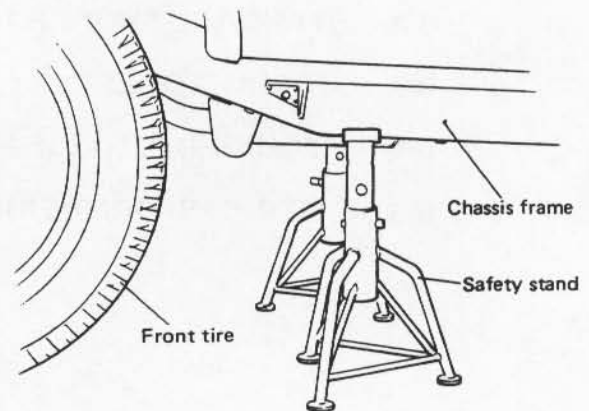

Fig. 0-5 Front Side

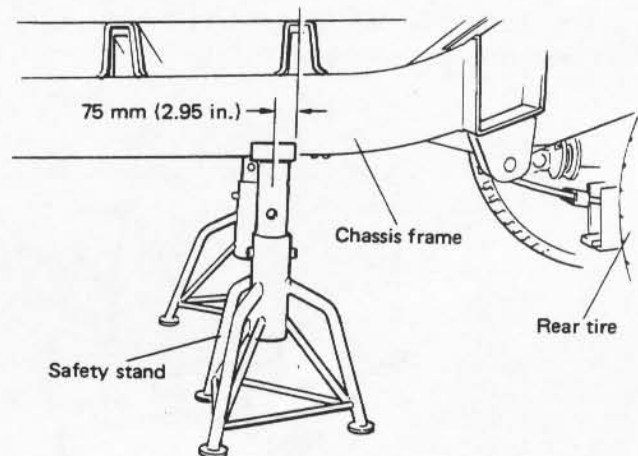

Fig. 0-6 Rear Side

5. Fig. 0-7 and 0-8 show how to lift the car by using a hoist.

WARNING:

- When using frame contact hoist, apply hoist as shown below (right and left at the same position). Lift up the car till 4 tires are a little off the ground and make sure that the car will not fall off by trying to move car body in both ways. Work can be started only after this confirmation.
- Before applying hoist to underbody, always take car balance throughout service into consideration. Car balance on hoist may change depending of what part to be removed.
- For suspension parts removal, follow previous steps 3 and 4.
- Make absolutely sure to lock hoist after car is hoisted up.

When using frame contact hoist:

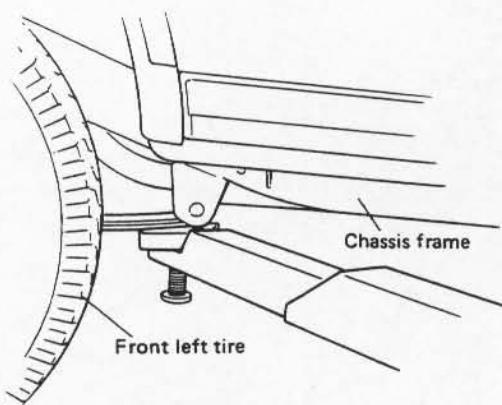

Fig. 0-7 Front Support Location

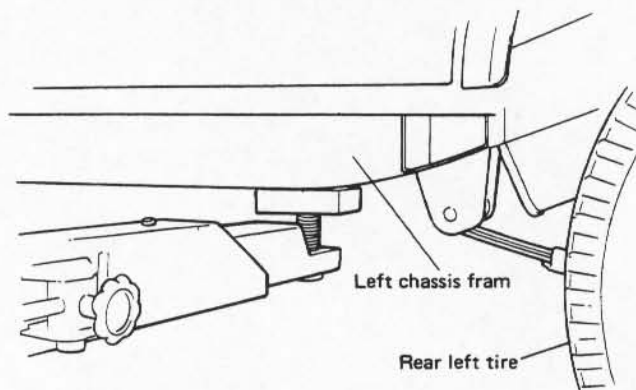

Fig. 0-8 Rear Support Location

6. Orderliness is a key to successful overhauling. Trays, pans and shelves are needed to set aside disassembled parts in groups or sets in order to avoid confusion and misplacement. This is particularly important for engine overhauling.
7. Have on hand liquid packing—SUZUKI BOND No. 1215 (99000-31110) — for ready use. This packing dope is an essential item to assure leak-free (water and oil) workmanship.
8. Each bolt must be put back to where it was taken from or for which it is intended. Do not depend on your hunch in tightening bolts for which tightening torque values are specified: be sure to use torque wrenches on those bolts.
9. It is advisable to discard and scrap gaskets and "O" rings removed in disassembly. Use new ones in reassembly, and try not to economize gaskets and "O" rings.
10. Use of genuine SUZUKI parts is imperative. Use of imitation parts is a big gamble on safety and performance. Use genuine SUZUKI parts and live up to the trust your customer places on you.
11. Special tools save time and ensure good workmanship: They are available from SUZUKI. Use them where their use is specified. Moreover, your own safety is assured by the use of special tools in many of the disassembly and reassembly steps.

12. Refer to the contents of this MANUAL as often as practical, and do each job properly as prescribed.

NOTE:

Engine cylinders are identified by numbers. See Fig. 0-9. Counting from the front end, the cylinders are referred to as No. 1, No. 2, No. 3 and No. 4 cylinders.

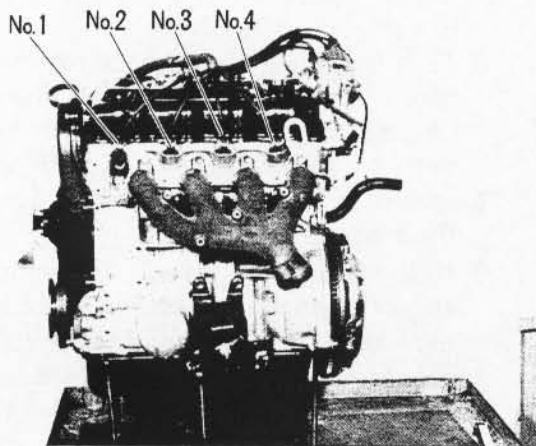

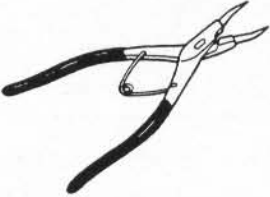
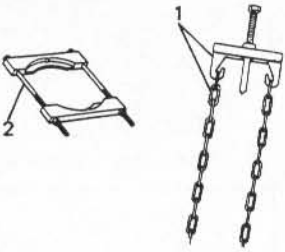
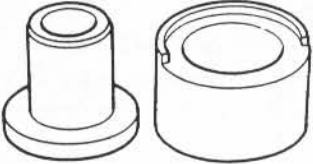

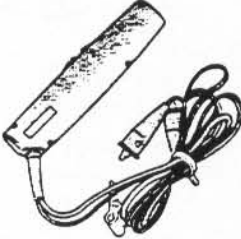

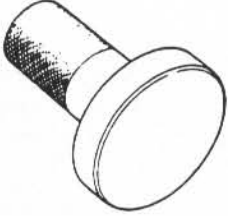
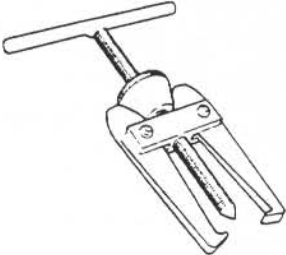

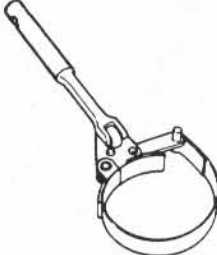
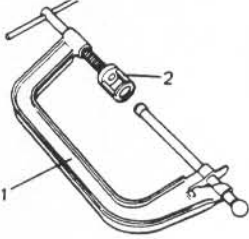

Fig. 0-9 Engine Cylinder Numbers

0-3. SPECIAL TOOLS

Special tools assure three things: 1) improved workmanship; 2) speedy execution of jobs for which they are meant; and 3) protection of parts and components against damage. Here are the special tools prescribed for this Model:

| | | | |
|---|---|--|---|
|  <p>09900-06107 Snap ring plier (opening type)</p> |  <p>09900-06108 Snap ring plier (closing type)</p> |  <p>1. 09927-18410 Universal puller 2. 09921-57810 Bearing remover</p> |  <p>09926-48010 Universal joint assembler</p> |
|  <p>09900-27311 Timing light (Dry cell type)</p> |  <p>09900-27301 Timing light (D.C. 12V)</p> |  <p>09932-28211 Carburetor float level gauge</p> |  <p>09913-75510 Differential rear outer race installer</p> |
|  <p>09913-60910 Bearing puller</p> |  <p>09918-38310 Carburetor adjuster set</p> |  <p>09915-47310 Oil filter wrench</p> |  <p>1. 09916-14510 Valve lifter 2. 09916-48210 Valve lifter attachment</p> |



09916-44511
Valve guide remover



09917-88210
Valve guide installer

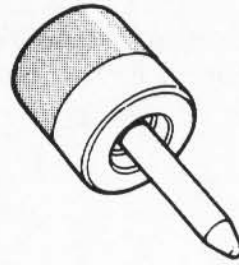

09917-98210
Valve stem seal installer



09916-34520
Reamer (7 mm)



09916-37310
Reamer (12 mm)

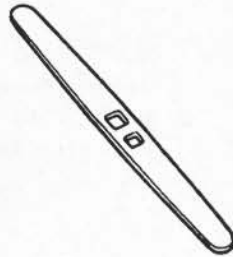

09916-34541
Reamer handle

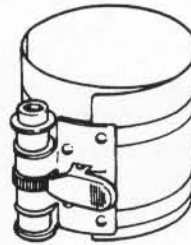

09916-77310
Piston ring compressor



09916-84510
Forceps

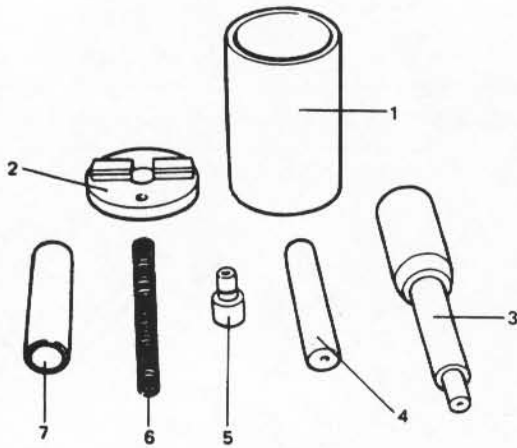

09910-38210
Piston pin remover and installer

1. Base
2. Base cap
3. Driver handle
4. Piston pin guide for installation
5. Piston pin guide for removal
6. Spring
7. Spring guide



09916-57321
Valve guide installer handle

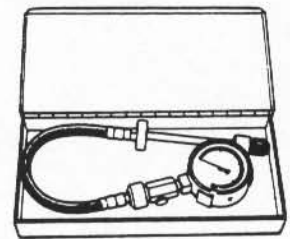



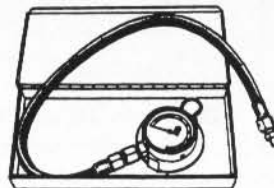

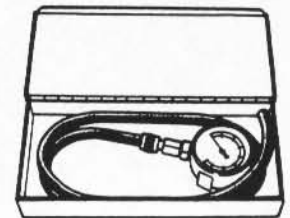

09915-64510
Compression gauge



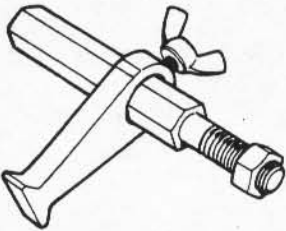
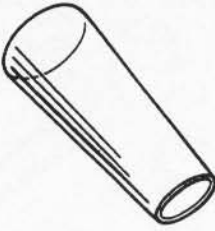

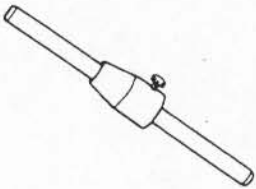
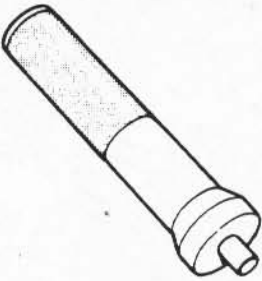
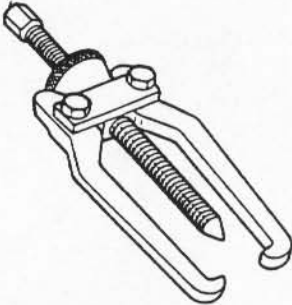

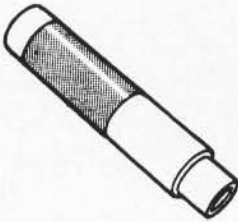
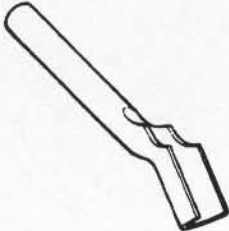
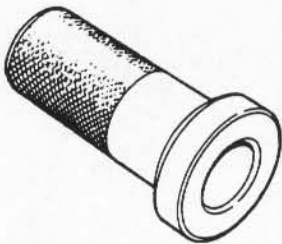
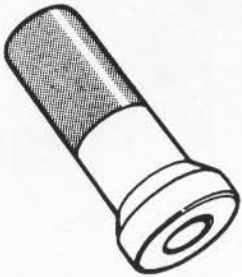
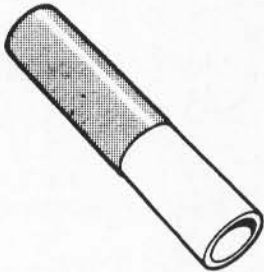
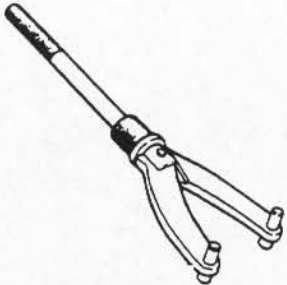
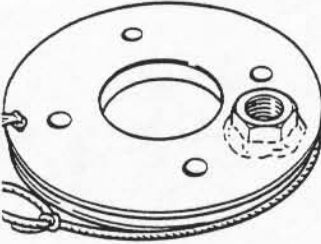

09915-77310
Oil pressure gauge

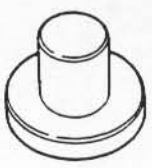
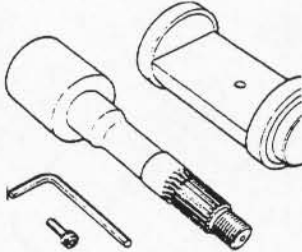

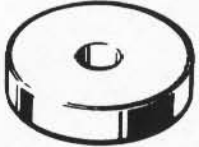
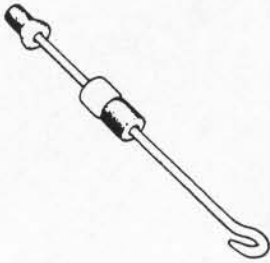
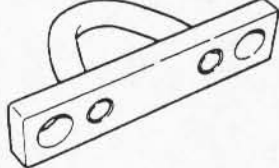

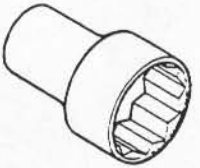
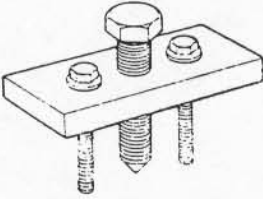
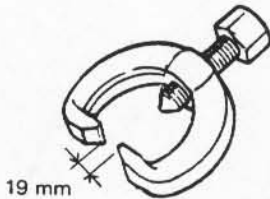
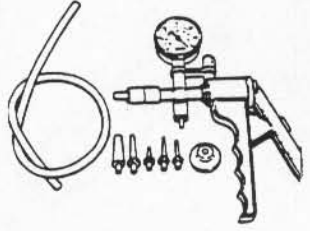
09915-67310
Vacuum gauge

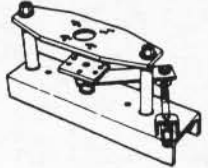
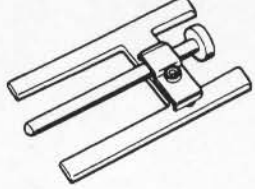
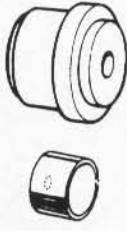
| | | | |
|--|--|---|--|
|  <p>09917-68210 Camshaft lock holder</p> |  <p>09924-17810 Flywheel holder</p> |  <p>09926-18210 Oil seal guide (Vinyl resin)</p> |  <p>09917-58010 Bearing remover (for input shaft bearing)</p> |
|  <p>09923-36330 Clutch center guide</p> |  <p>09925-98210 Input shaft bearing installer</p> |  <p>09913-65135 Transmission and transfer bearing and gear remover</p> |  <p>09922-85811 Spring pin remover (4.5 mm)</p> |
|  <p>09925-18010 Transmission gear, bush and bearing installer</p> |  <p>09925-48210 Clutch release bush remover</p> |  <p>09913-75810 Transfer bearing installer</p> |  <p>09913-76010 Transfer bearing installer</p> |
|  <p>09913-84510 Transfer bearing installer</p> |  <p>09930-40113 <ul style="list-style-type: none"> • Transfer flange lock holder • Differential side bearing adjuster </p> |  <p>09922-75221 <ul style="list-style-type: none"> • Center brake drum lock holder • Differential bearing preload checking tool </p> |  <p>09926-58010 Bearing puller attachment (transfer)</p> |



| | | | |
|--|---|---|---|
|  <p>09913-85230 Differential side bearing remover jig</p> |  <p>09926-78310 Differential bevel pinion mounting dummy</p> |  <p>09940-53111 Differential side bearing installer</p> |  <p>09924-74510 Bearing installer attachment</p> |
|  <p>09926-68310 Differential pinion bearing installer</p> |  <p>09942-15510 Sliding hammer</p> |  <p>09922-66010 Rear axle shaft remover</p> |  <p>09943-35511 Brake drum remover</p> |
|  <p>09941-58010 50 mm socket wrench</p> |  <p>09944-36010 Steering wheel remover</p> |  <p>09913-65210 Tie-rod end remover</p> |  <p>09917-47910 Vacuum pump gauge</p> |
|  <p>09950-78210 Flare nut wrench (10 mm)</p> |  <p>09950-88210 Booster overhaul tool set</p> |  <p>09950-98210 Booster piston rod gauge</p> |  <p>No. 1 09951-08210</p> <p>No. 2 09951-18210</p> <p>Booster No. 2 body Oil seal remover & Installer No. 1, No. 2</p> |

0-4. REQUIRED SERVICE MATERIALS

The materials listed below are needed for maintenance work on these cars, and should be kept on hand for ready use. In addition, such standard materials as cleaning fluids, lubricants, etc., should also be available. Methods and time of use are discussed in the text of this manual on later pages.

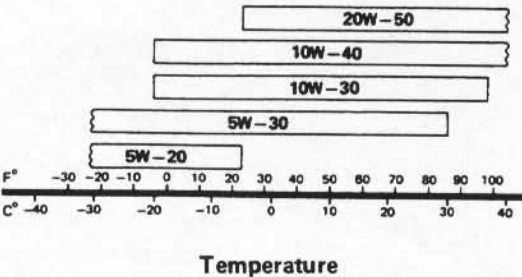
| Ref. No. | Material | | Use |
|----------|---|---|--|
| 1. | GOLDEN CRUISER 1200 "Anti-freeze/Anti-corrosion Coolant" | | Additive to engine cooling system for improving cooling efficiency and for protection of wet walls against rusting. |
| 2. | SUZUKI SUPER GREASE A (99000-25010) |  | <ul style="list-style-type: none"> • For locations indicated in the section dealing with the starter motor. • Clutch release bearing retainer. • Clutch release shaft bushing. • Transmission oil seal. • Differential oil seal. • Wheel bearings. • Gear shifting control lever bushing & seat. • Door window regulators. • For other locations specifically indicated in the text of this manual. |
| 3. | SUZUKI GREASE SUPER H (99000-25120) |  | Special grease intended for use on constant velocity joints. |
| 4. | SUZUKI BOND NO. 1215 (99000-31110) |  | <ul style="list-style-type: none"> • For top and bottom mating faces of transmission case. • For other locations specifically indicated in the text of this manual. |

| | | |
|----|---|---|
| 5. | CHASSIS GREASE | <ul style="list-style-type: none"> • For grease nipples on propeller shafts. • For propeller shaft splines. |
| 6. | <p>GEAR OIL SAE 90, 80W or 75W 80 – 85 for cars used in such areas where the ambient temperature becomes lower than -15°C (5°F) during the coldest season, it is recommended that oils be changed with SAE80W or 75W/80 – 85 oils on such occasion of service as periodic maintenance.</p> | <ul style="list-style-type: none"> • Transmission case 1.3 ltr. (2.7/2.3 US/Imp. pt.) • Transmission gear and bearing • Transfer case 0.8 ltr. (1.7/1.4 US/Imp. pt.) • Steering gear box • Differential gear box (Hypoid gear oil) Rear 1.5 ltr. (3.2/2.6 US/Imp. pt.) Front 2.0 ltr. (4.2/3.5 US/Imp. pt.) |
| 7. | SEALANT (99000-31150) | <ul style="list-style-type: none"> • For mating surfaces of engine oil pan and cylinder block. |
| 8. | <p>4-STROKE ENGINE OIL It is recommended to use engine oil of SD, SE or SF class.</p> <p>Proper Engine Oil Viscosity Chart</p>  <p>The chart shows five horizontal bars representing the temperature ranges for different oil grades. The x-axis is labeled 'Temperature' and has two scales: Fahrenheit (F°) from -30 to 100 and Celsius (C°) from -40 to 40. The bars are as follows:</p> <ul style="list-style-type: none"> 5W-20: From -30°F to 20°F (-30°C to 0°C) 5W-30: From -20°F to 30°F (-20°C to 10°C) 10W-30: From -10°F to 40°F (-10°C to 10°C) 10W-40: From 0°F to 50°F (0°C to 10°C) 20W-50: From 10°F to 60°F (10°C to 10°C) | <ul style="list-style-type: none"> • For engine oil pan: (For periodical oil change) • Crank journal bearings and thrust plate. • Connecting-rod big-end and small-end bearings. • Camshaft journals. • Rocker shafts. • Oil pump gears. • Pistons and piston rings. • Engine oil seals. • Valve stems. • Accelerator, choke (if equipped) and clutch cables. • Parking brake cable. • Accelerator, brake and clutch pedal shafts. • Door locks and hinges. • Distributor gear. |

| | | | |
|-----|---|---|---|
| 9. | SEALING COMPOUND "CEMEDINE" 366E (Water tight sealant) (99000-31090) 180 ml | | <ul style="list-style-type: none"> ● King pin shim face. ● For steering knuckle (rear axle housing) and brake packing plate mating surface. ● For other locations specifically indicated in the text of this manual. |
| 10. | THREAD LOCK CEMENT SUPER 1333B (99000-32020) |  | <ul style="list-style-type: none"> ● Transmission reverse gear shift lim bolt. ● Gear shift lever locating bolt. ● Differential drive bevel gear bolt. |
| 11. | BRAKE FLUID "DOT3" or SAE J1703 | | <ul style="list-style-type: none"> ● To fill master cylinder reservoir. ● To clean and apply to inner parts of master cylinder, caliper and wheel cylinder when they are disassembled. |
| 12. | SILICONE GREASE (Furnished in repair kit) | | <ul style="list-style-type: none"> ● To apply to brake booster inner parts where application is instructed in this manual. |
| 13. | THREAD LOCK CEMENT "1342" (99000-32050) |  | <ul style="list-style-type: none"> ● King pin bolt |
| 14. | SUZUKI SUPER GREASE I (99000-25210) | | <ul style="list-style-type: none"> ● Transmission input shaft |
| 15. | SUZUKI SUPER GREASE C (99000-25030) | | <ul style="list-style-type: none"> ● Propeller shaft spider bearing |

0-5. METRIC INFORMATION

METRIC FASTENERS

Most of the fasteners used for this vehicle are metric. When replacing any fasteners, it is most important that replacement fasteners be the correct diameter, thread pitch and strength.

FASTENER STRENGTH IDENTIFICATION

Most commonly used metric fastener strength property classes are 4T, 7T and radial line with the class identification embossed on the head of each bolt. Some metric nuts will be marked with punch mark strength identification on the nut face. Fig. 0-10 shows the different strength markings.

When replacing metric fasteners, be careful to use bolts and nuts of the same strength or greater than the original fasteners (the same number marking or higher). It is likewise important to select replacement fasteners of the correct size. Correct replacement bolts and nuts are available through the parts division.

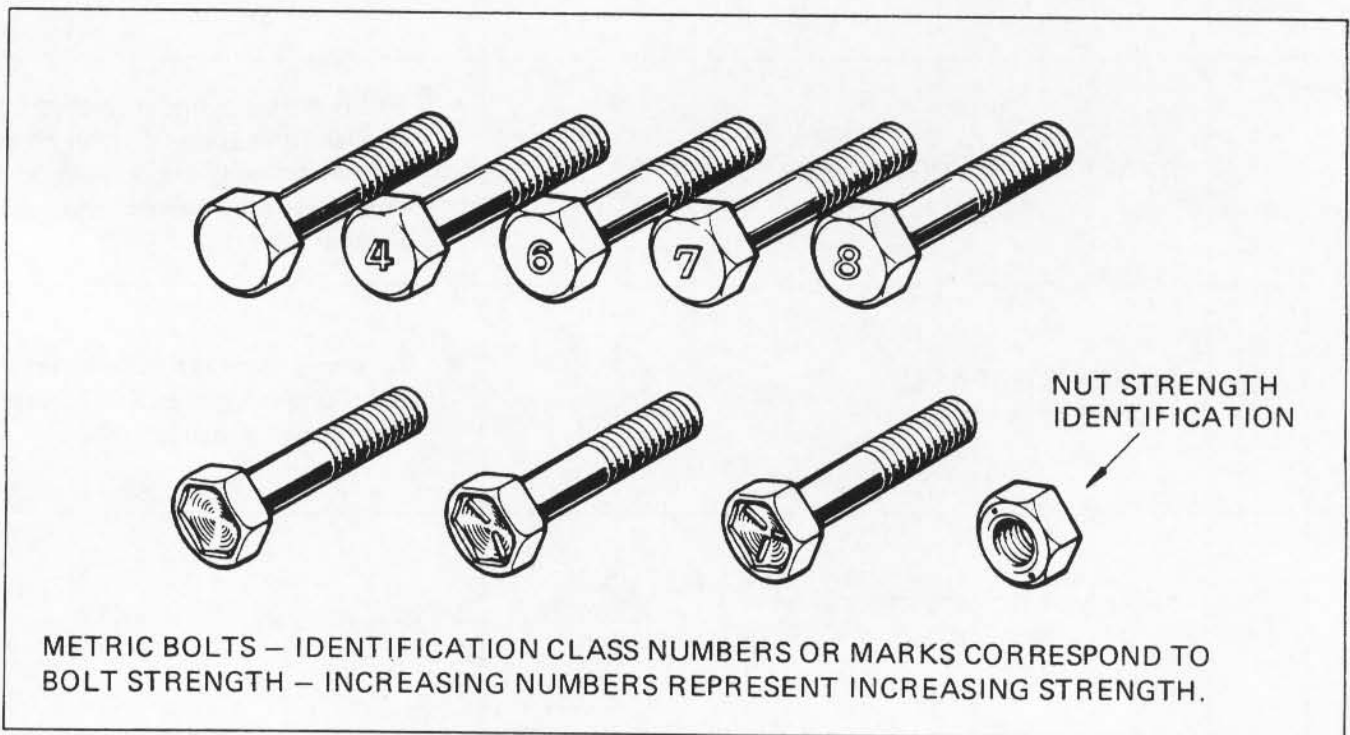

Fig. 0-10 Bolt Strength Markings

STANDARD TIGHTENING TORQUE

Each fastener should be tightened to the torque specified in each section of this manual. If no description or specification is provided, refer to the following tightening torque chart for the applicable torque for each fastener. When a fastener of greater strength than the original one is used, however, use the torque specified for the original fastener.

NOTE:

- For the flanged bolt and nut, add 10% to the tightening torque given in the below chart.
- The below chart is applicable only where the fastened parts are made of steel or light alloy.

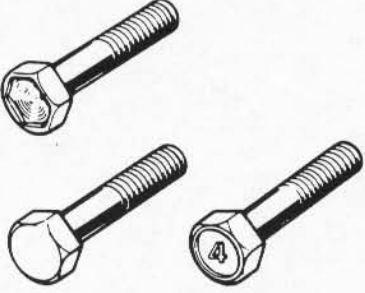
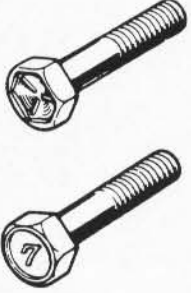
| STRENGTH THREAD DIAMETER (mm) |  Conventional bolt "4T" bolt | | |  "7T" bolt | | |
|--|--|-------------|--------------|--|-------------|---------------|
| | N·m | kg·m | lb·ft | N·m | kg·m | lb·ft |
| 4 | 1 – 2 | 0.1 – 0.2 | 0.7 – 1.0 | 1.5 – 3.0 | 0.15 – 0.30 | 1.5 – 2.0 |
| 5 | 2 – 4 | 0.2 – 0.4 | 1.5 – 3.0 | 3 – 6 | 0.3 – 0.6 | 2.5 – 4.0 |
| 6 | 4 – 7 | 0.4 – 0.7 | 3.0 – 5.0 | 8 – 12 | 0.8 – 1.2 | 6.0 – 8.5 |
| 8 | 10 – 16 | 1.0 – 1.6 | 7.5 – 11.5 | 18 – 28 | 1.8 – 2.8 | 13.5 – 20.0 |
| 10 | 22 – 35 | 2.2 – 3.5 | 16.0 – 25.0 | 40 – 60 | 4.0 – 6.0 | 29.0 – 43.0 |
| 12 | 35 – 55 | 3.5 – 5.5 | 25.5 – 39.5 | 70 – 100 | 7.0 – 10.0 | 51.0 – 72.0 |
| 14 | 50 – 80 | 5.0 – 8.0 | 36.5 – 57.5 | 110 – 160 | 11.0 – 16.0 | 80.0 – 115.5 |
| 16 | 80 – 130 | 8.0 – 13.0 | 58.0 – 94.0 | 170 – 250 | 17.0 – 25.0 | 123.0 – 180.5 |
| 18 | 130 – 190 | 13.0 – 19.0 | 94.5 – 137.0 | 200 – 280 | 20.0 – 28.0 | 145.0 – 202.5 |

Fig. 0-11 Tightening Torque Chart