

SECTION 15

PROPELLER SHAFTS

CONTENTS

15-1. GENERAL DESCRIPTION	15-2
15-2. REMOVAL	15-3
15-3. INSTALLATION	15-3
15-4. MAINTENANCE SERVICES	15-4
15-5. TIGHTENING TORQUE	15-5
15-6. DISASSEMBLY	15-6
15-7. REASSEMBLY	15-7

15-1. GENERAL DESCRIPTION

These automobiles, covered in this manual are four-wheel drive machines and, as such, use three propeller shafts designated as No. 1, No. 2 and No. 3.

No. 1 propeller shaft transmits drive from the transmission to the transfer gear box. No. 2 shaft and No. 3 shaft extend from the transfer gear box, the former driving the front axle and the latter the rear axle.

The cross spider in each universal joint is fitted with four needle roller bearings.

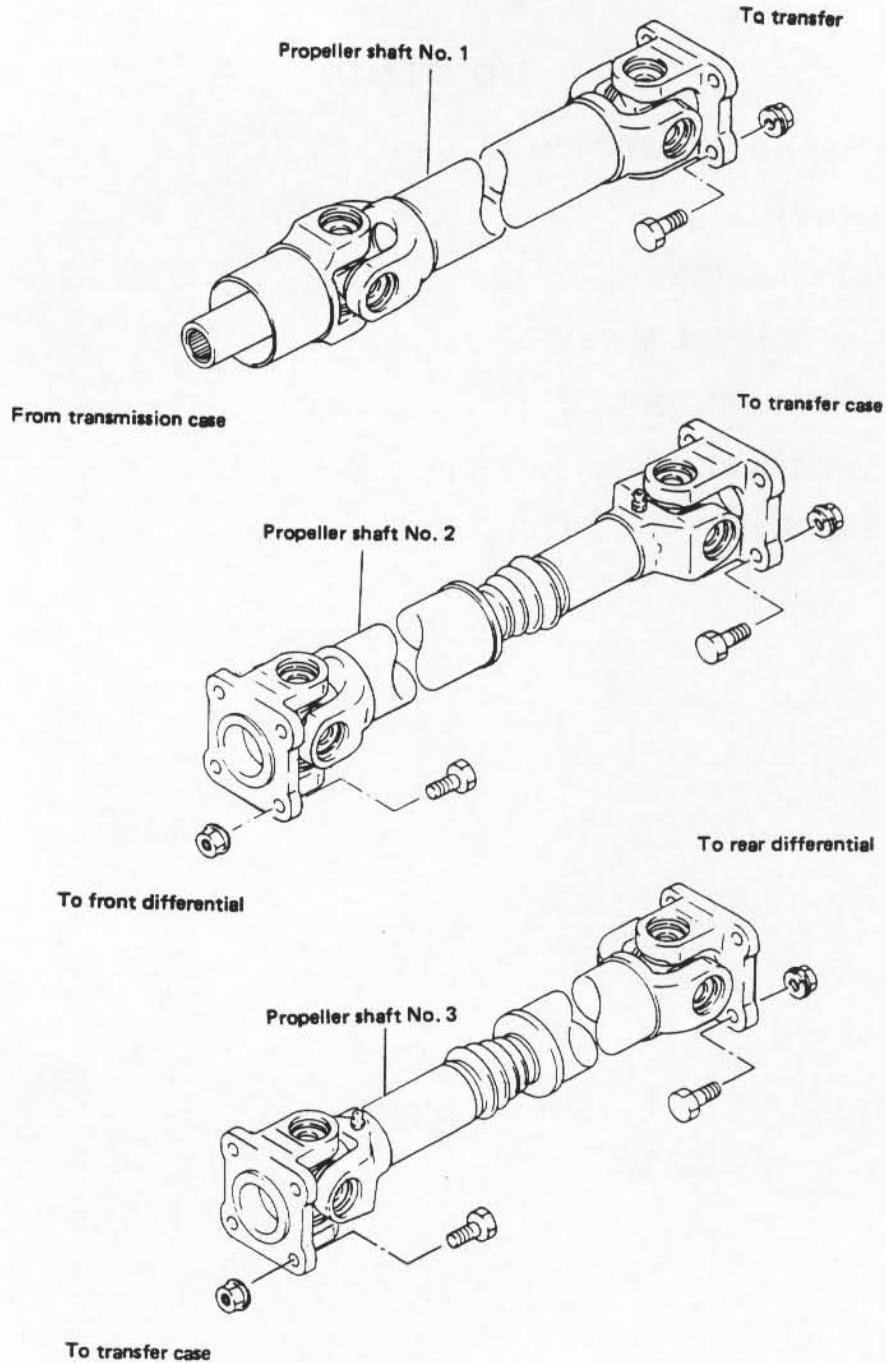

Fig. 15-1

15-2. REMOVAL

- 1) Hoist car.
- 2) Loosen propeller shaft nuts and bolts.
- 3) Remove propeller shaft.

Transmission-side end of No. 1 shaft has no flange piece; this end is splined to driving shaft inside extension case. All you have to do there is to pull No. 1 shaft off extension case.

NOTE:

When withdrawing propeller shaft No. 1 from transmission, transmission oil will not leak, provided oil level is to specification and car is raised horizontally in its front and rear direction. However, if only car front is hoisted, be sure to drain transmission oil before withdrawing propeller shaft No. 1.

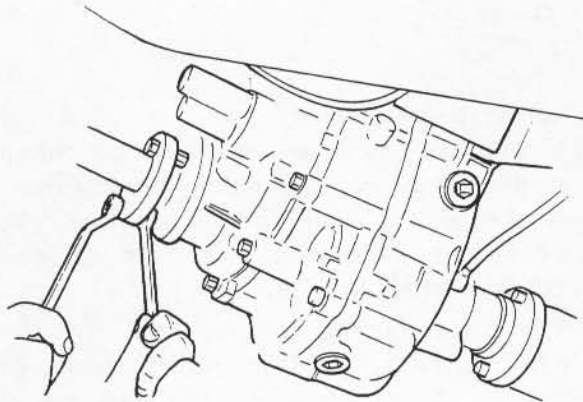

Fig. 15-2

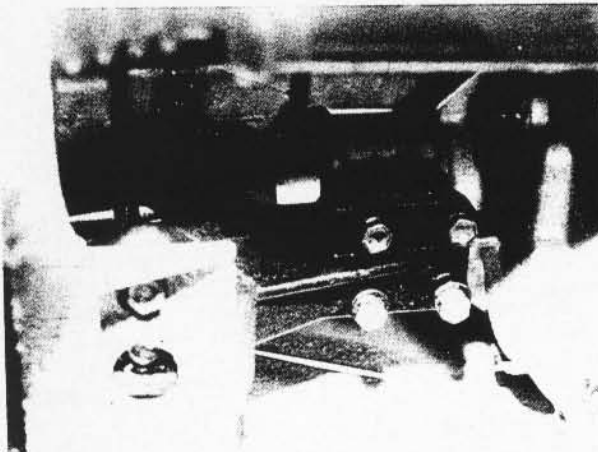

Fig. 15-3

15-3. INSTALLATION

The installing procedure is reverse of the removal procedure. Be sure to adhere to following instructions when installing shafts:

- Flange tightening torque
Be sure to tighten 4 nuts to the following torque when securing companion flange to yoke at each end of propeller shaft:

Tightening torque for universal joint flange bolts & nuts	23 – 30 N·m (2.3 – 3.0 kg·m) (17.0 – 21.5 lb-ft)
---	--

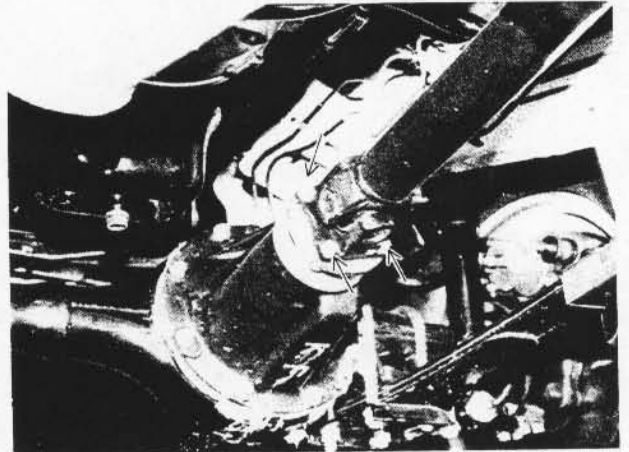

Fig. 15-4

- Grease splines liberally, filling grooves with grease.

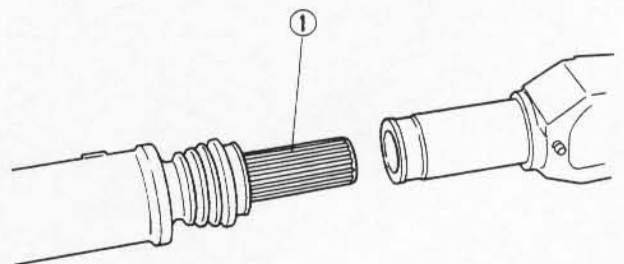

Fig. 15-5 ① Grease (chassis grease)

- Joint sheath rubber has a large diameter in one end and a small diameter in the other. Be sure to fit sheath rubber with its large-diameter end brought to joint yoke side.

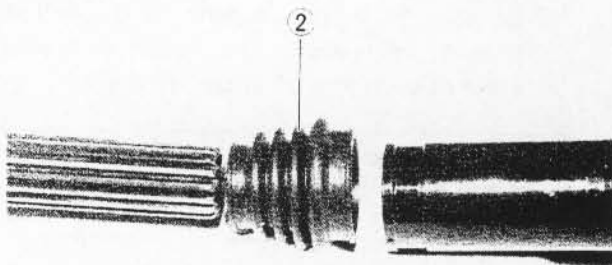

Fig. 15-6 ② Joint sheath rubber

NOTE:

If transmission oil was drained for propeller shaft No. 1 removal, pour specified gear oil into transmission case to specified level.

- Match marks are provided on slip-on spline connections. Inserting splined end into splined bore without regard to match marks can be a possible cause of noise or vibration of propeller shaft. Be sure to index marks.

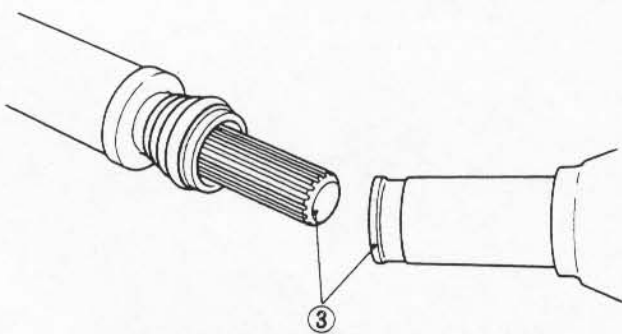

Fig. 15-7 ③ Match marks

15-4. MAINTENANCE SERVICES

Lubrication

Inside yoke of each universal joint has a grease nipple. At regular intervals stated in the recommended servicing schedule, pump in grease to relubricate joint. Use chassis grease.

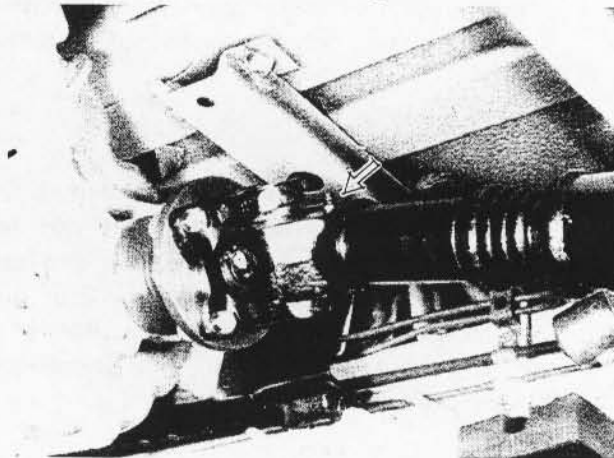

Fig. 15-8

Universal Joint Noise

If universal joints are suspected of producing chattering or rattling noise, inspect them for wear. Check to see if cross spider rattles in yokes or if splines are worn down and replace defective propeller shaft with new one.

The noise coming from universal joint can be easily distinguished from other noises because rhythm of chattering or rattling is in step with cruising speed. Noise is pronounced particularly on standing start or in coasting condition (when braking effect of engine is showing in the drive line).

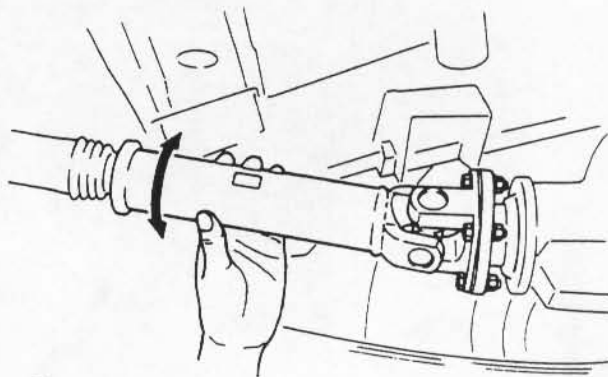

Fig. 15-9

15-5. TIGHTENING TORQUE

Bolts & Nuts

Check following bolts and nuts for tightness and retighten them as necessary:

Fastening parts	N·m	kg-m (lb-ft)
Propeller shaft bolt & nut	23 – 30	2.3 – 3.0 (17.0 – 21.5)

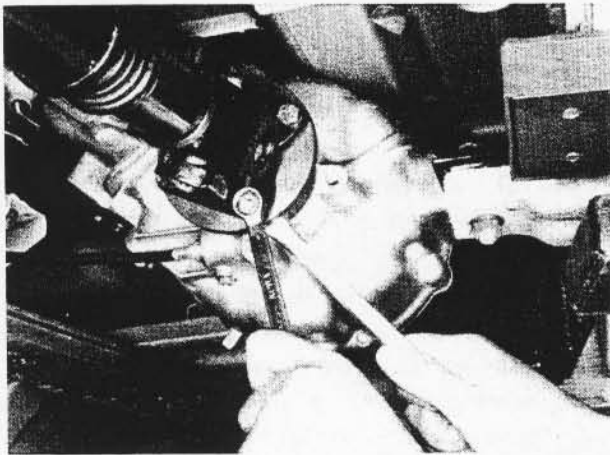

Fig. 15-10

15-6. DISASSEMBLY

- Disassembling on propeller shaft yoke side.

1) Using snap ring pliers (Special tool), remove 2 circlips.

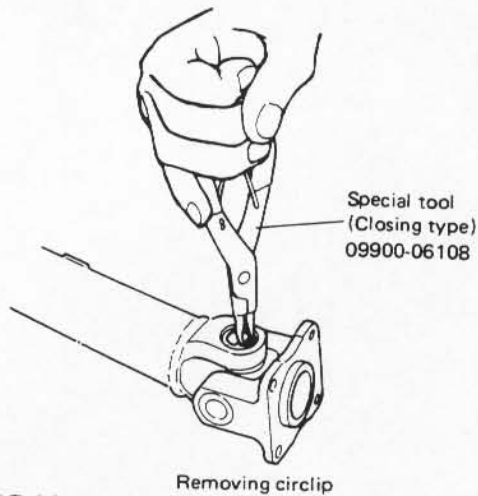

Fig. 15-11

2) Using universal joint assembler (Special tool 09926-48010), push spider bearing race out 3 – 4 mm (0.12 – 0.16 in.) from shaft yoke race.

NOTE:

Before pushing it out, apply penetrate lubricant between bearing race and yoke race.

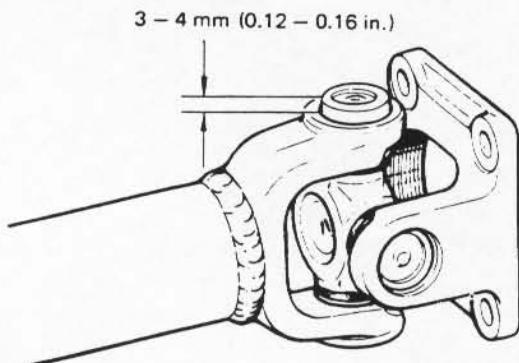
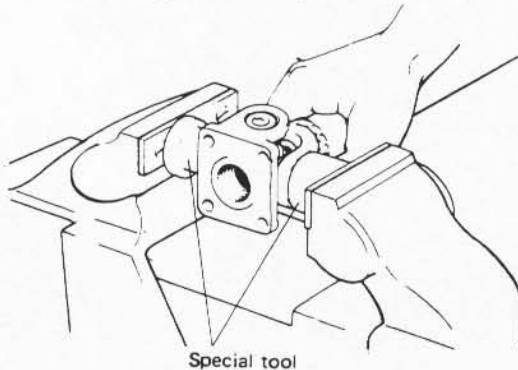

Fig. 15-12

3) Tapping yoke with a hammer, completely remove bearing race.

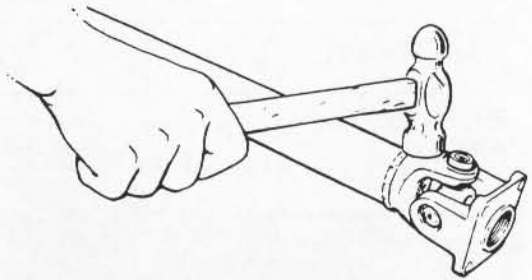

Fig. 15-13

4) Take out bearing race on the other side in the same way as in 2) and 3).

- Disassembling on flange yoke side

Push out bearing race on flange yoke side as described in 1) and 2), and then, holding bearing race in a vice, tap flange yoke and take out race. (Refer to the below figure.)

Remove bearing race on the opposite side in the same way.

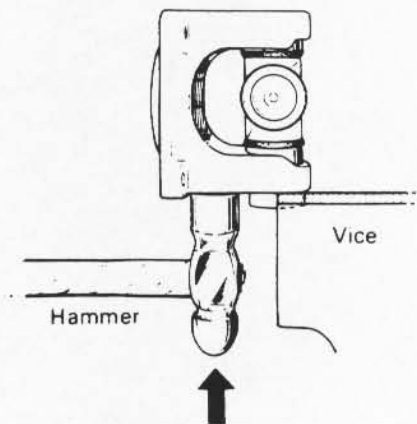

Fig. 15-14

NOTE:

- Take care not to lose rollers in spider bearing race when removing it.
- Fit removed bearings temporarily in spider so that they can be reinstalled in their original positions.

15-7. REASSEMBLY

NOTE:

- Make certain that rollers inside spider bearing race are all in place.
- Make sure to apply SUPER GREASE C (99000-25030) to spider bearing race.



Fig. 15-15

CAUTION:

In reassembly, be sure to use new circlips, spider and bearings. Reuse of circlips, spider and bearings once reassembled is prohibited.

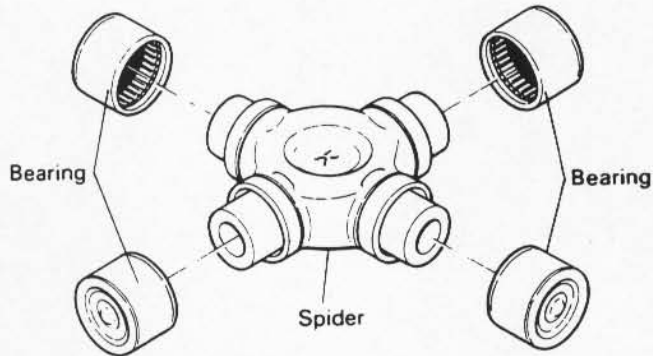

Fig. 15-16

- 1) Insert bearing race into yoke, tapping it with a hammer, until it is flush with yoke face. When doing this, insert spider into bearing race to prevent rollers in bearing race from coming out.

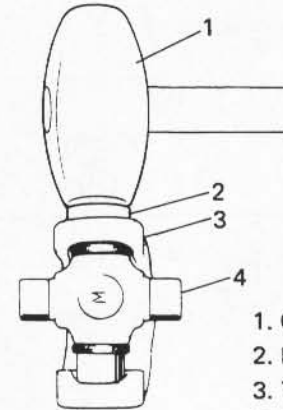

Fig. 15-17

1. Copper hammer
2. Bearing race
3. Yoke
4. Spider

- 2) Insert the other bearing race on the opposite side into yoke, tapping with a hammer until it is flush with yoke face.
- 3) Insert bearing races on the flange yoke side in the same way as described in 1) and 2) above.

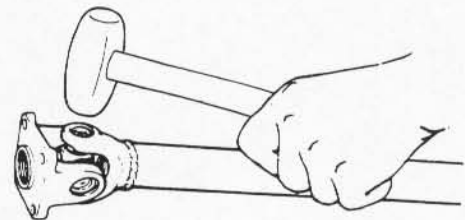

Fig. 15-18

- 4) Place a metal plate on bearing races when tapping them in to avoid damaging yoke.
- 5) Securely fit 4 circlips to shaft and flange yoke.

NOTE:

- After reassembly, check to ensure that both shaft yoke and flange yoke move smoothly.
- Make sure that each circlip is fitted in the groove securely.

6) Inspect propeller shaft and flange yoke for damage, and propeller shaft for runout. If damage is found or shaft runout exceeds specifications, replace.

Runout limit	0.8 mm (0.031 in.)
--------------	-----------------------

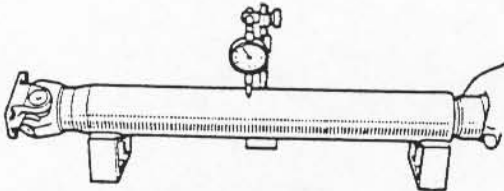

Fig. 15-19