

## SECTION 8

# IGNITION SYSTEM

### CONTENTS

<b>8-1. GENERAL DESCRIPTION</b> .....	<b>8-2</b>
DISTRIBUTOR .....	8-3
IGNITION COIL .....	8-4
SPARK PLUG .....	8-4
<b>8-2. MAINTENANCE SERVICE</b> .....	<b>8-5</b>
HIGH TENSION CORD .....	8-5
SPARK PLUG .....	8-5
IGNITION COIL .....	8-5
DISTRIBUTOR .....	8-5
IGNITION TIMING .....	8-8
DISTRIBUTOR DRIVE GEAR .....	8-9
<b>8-3. IMPORTANT REMINDERS FOR INSTALLATION</b> .....	<b>8-10</b>
DISTRIBUTOR .....	8-10

## 8-1. GENERAL DESCRIPTION

The ignition system is of contact-pointless type (full-transistorized type).

The principal components of the ignition system are spark plugs, ignition coil, and distributor. The distributor has a rotor, an ignitor, a signal generator, a vacuum advancer and a centrifugal advancer.

The signal generator is to generate the ignition signal and consists of a signal rotor, a magnet and a pickup coil. The signal rotor is attached to the distributor shaft, and the magnet and the pickup coil are attached to the generator base plate.

When the distributor shaft rotates, the magnetic flux passing through the pickup coil varies due to the change in air gap between the pickup coil and the signal rotor. As a result, the alternating current voltage is induced in the pickup coil. The voltage induced turns on and off the ignitor which switches off the ignition coil primary current. Thus, the high voltage is induced in the secondary winding of ignition coil and ignition sparks are generated at the spark plugs.

The distributor is a sort of rotary switch, whose rotor connects the four plugs, one at a time, to secondary winding of the ignition coil through the wires called "high-tension" cords. Note that there are one high-tension cord, from secondary winding to the center of the distributor cap, and four more high-tension cords between the spark plugs and the four terminals on the cap.

### NOTE:

Whereabouts of terminal connections are clearly indicated in the diagram below. When inspecting the electrical wiring, refer to this diagram and check to be sure that each connection is tight. Examine the cords for torn insulation and for evidence of grounding.

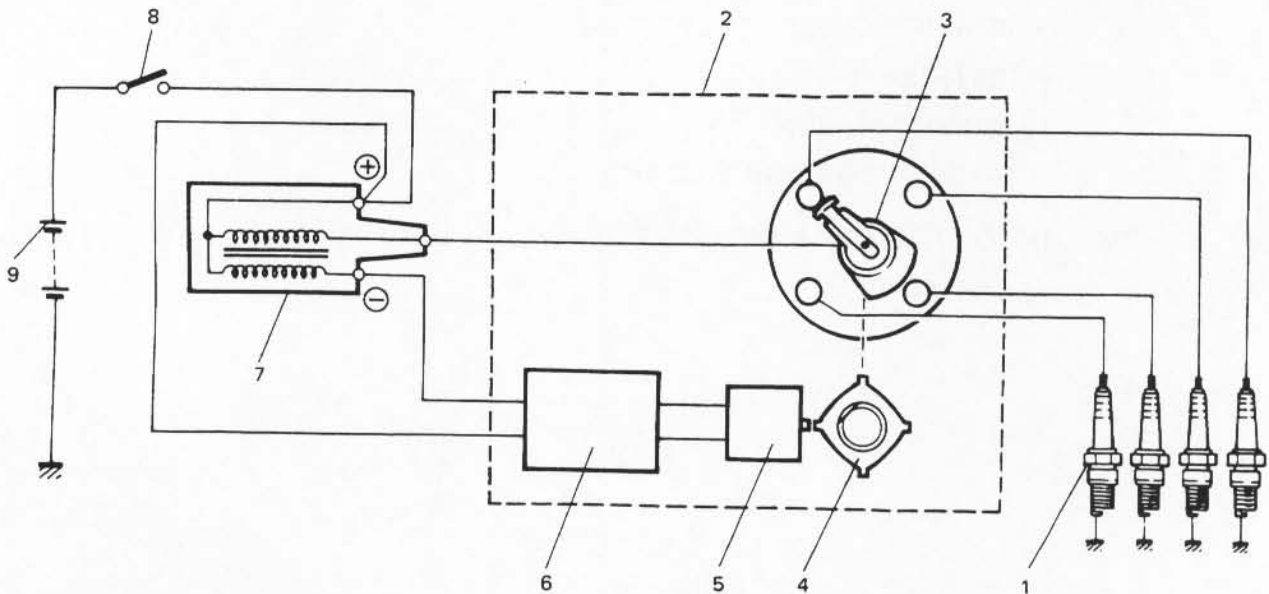

1. Spark plug
2. Distributor
3. Distributor rotor
4. Signal rotor
5. Generator
6. Ignitor
7. Ignition coil
8. Ignition switch
9. Battery

Fig. 8-1

## Distributor

1. Vacuum controller
2. Distributor cap
3. Seal
4. Distributor housing
5. Distributor driven gear
6. Pin
7. O-ring
8. Rotor
9. Signal generator dust cover
10. Ignitor dust cover
11. Generator assembly
12. Generator base plate
13. Signal rotor

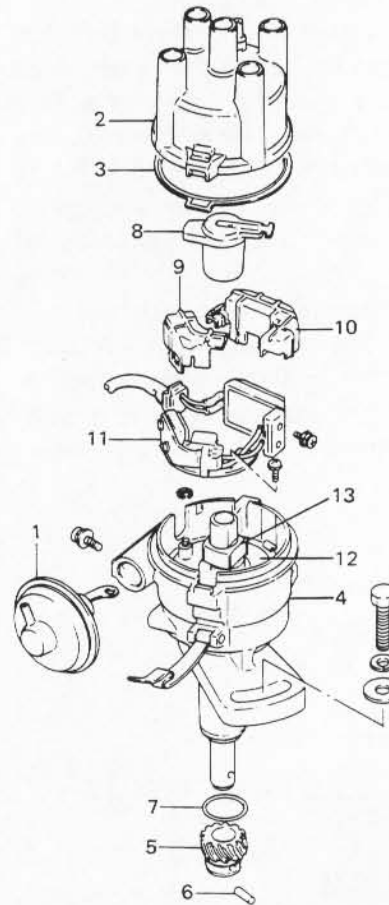

Fig. 8-2

### [Timing advancer]

The distributor shaft, from its driven-gear end to the rotor-carrying end, is not a single solid piece; actually this shaft is in two pieces connected together through the timing advancer. The advancer is essentially a flyweight mechanism. Timing advancing action is accomplished by twisting the top shaft piece relative to the bottom one in the direction of shaft rotation. The single rotor is mounted on the top piece. The twisting movement is produced by the speed-dependent radial (or spreading) movements of the two flyweights.

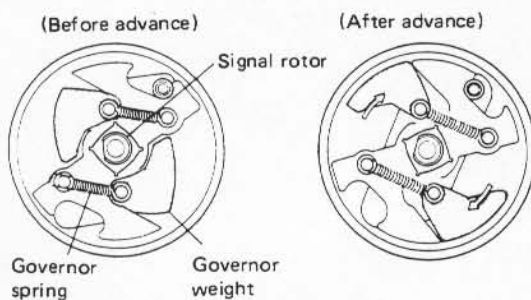

Fig. 8-3

### [Vacuum advancer]

In this vacuum-advance mechanism, when the vacuum in the carburetor gets high, the pressure acting on the diaphragm overcomes the spring force in it and the controller rod attached to the diaphragm is pulled. And the rod so pulled turns the generator base plate counter to the direction of the distributor shaft rotation (counterclockwise) to advance (quicken) the ignition.

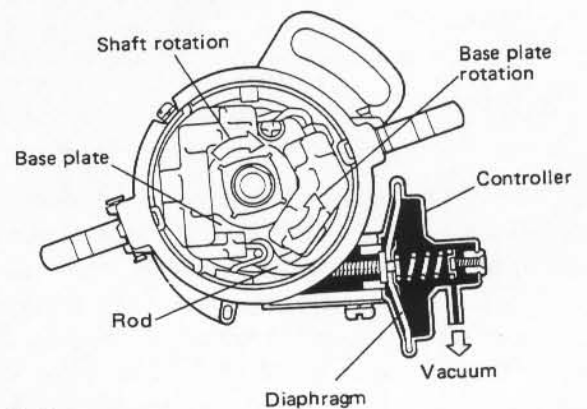

Fig. 8-4

### Ignition Coil

The ignition coil is a sort of miniature transformer and, as such, has an iron core around which two coils are wound — primary and secondary windings mentioned above. The two are so close to each other that a sudden change in the magnetic flux produced by “primary current” flowing in primary winding (in a less number of coil turns) induces a very large electromotive force (voltage) in secondary winding (in a greater number of coil turns). These live parts are housed in a tight, insulator case topped by the cap. Note that the cap has three terminals: one high-tension terminal and two low-tension terminals.

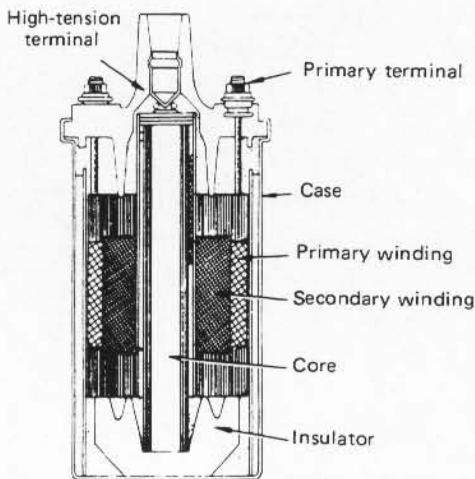

Fig. 8-5

### Spark Plugs

Each new machine shipped from the factory is fitted with standard plugs.

	Standard type	Cold type
NGK	BP-5ES (BPR-5ES)	BP-6ES (BPR-6ES)
Nippon Denso	W16EX-U (W16EXR-U)	W20EX-U (W20EXR-U)

As can be seen in the above table, two kinds of spark plugs are used in this car, one without R mark and the other with R mark which is indicated in parentheses, depending on countries. Look at the label attached to the car. If originally equipped plugs were with R mark, plugs with R mark should be used for replacement.

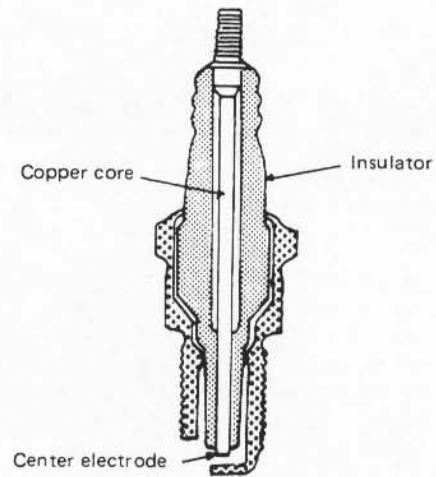

Fig. 8-6

## 8-2. MAINTENANCE SERVICE

### High Tension Cords

Check cord terminals for corrosion, breaks and distortion, and cords for crack or deterioration. Replace cord as necessary.

#### NOTE:

**DO NOT** bend or pull high tension cords to avoid inside damage. Grip rubber boot when removing or installing cords.

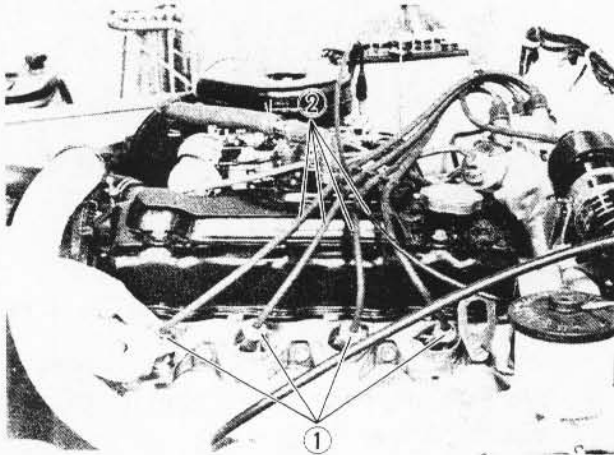

1. Rubber boot
2. High tension cord

Fig. 8-7

### Spark Plugs

Check following:

- Electrode wear
- Carbon deposits
- Insulator damage.

If any fault is found, replace plugs.

Check gap, and make sure that gap is within specification. If gap is out of specification, adjust it by bending ground (side) electrode.

Plug gap "A"	0.7 – 0.8 mm (0.027 – 0.031 in.)
--------------	-------------------------------------

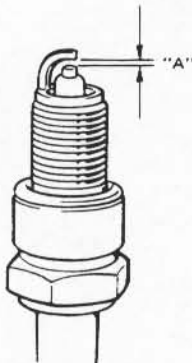

Fig. 8-8

### Ignition Coil

Disconnect negative cable at battery. Disconnect lead wires and high tension cord from ignition coil. Remove ignition coil, and check it as follows.

Measure primary coil resistance.

Using ohmmeter, measure resistance between positive  $\oplus$  and negative  $\ominus$  terminals.

Primary coil resistance	1.35 – 1.65 $\Omega$
-------------------------	----------------------

Measure secondary coil resistance.

Using ohmmeter, measure resistance between positive  $\oplus$  terminal and high tension terminal.

Secondary coil resistance	11.0 – 14.5 k $\Omega$
---------------------------	------------------------

#### NOTE:

Take readings when coil is about 20°C (68°F).

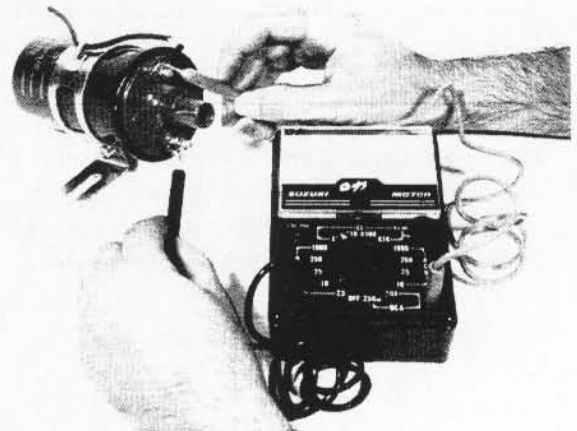

Fig. 8-9

Reverse removal procedure for installation.

When reinstalling, make sure that each connection is tight.

### Distributor

[Distributor cap]

Leakage of high-tension energy for ignition shows up as misfiring in the engine. It occurs at any part of the high-tension line where insulation has failed or in a dirty distributor cap, that is, an internally dirty cap.

A wider spark gap in the plug, a condition often found in poorly cared spark plugs, promotes a tendency of high-tension energy to find a short-cut to ground.

Cleanliness is very important for the distributor cap. With a clean dry cloth, wipe off dust or grime, if any, and inspect for any damaged (scarred, scratched or cracked) part or any part evidencing high-tension leakage inside the cap. Be sure to replace such parts.

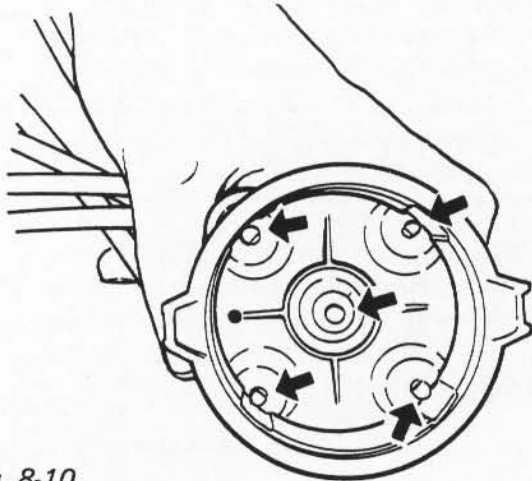

Fig. 8-10

[Signal rotor air gap]

Signal rotor air gap	0.2 – 0.4 mm (0.008 – 0.016 in)
----------------------	------------------------------------

Check air gap and adjust it as necessary.

1. Remove distributor cap and rotor.
2. Using thickness gauge, measure air gap between signal rotor tooth and generator.

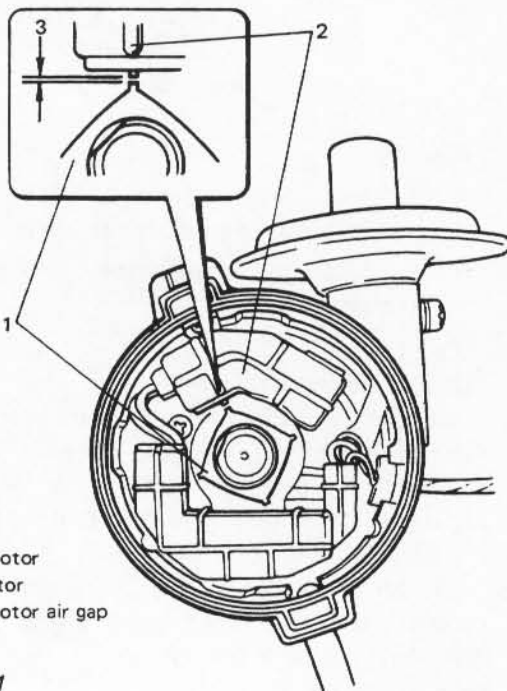

1. Signal rotor
2. Generator
3. Signal rotor air gap

Fig. 8-11

3. If air gap is out of specification, adjust it. Remove distributor and then ignitor. Loosen 2 screws securing generator. Using blade (–) screwdriver, move generator and adjust air gap to specification.

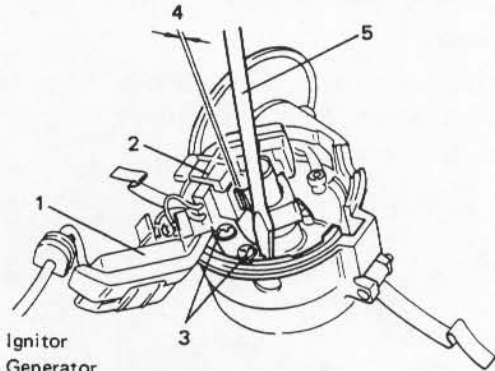

1. Ignitor
2. Generator
3. Generator screw
4. Signal rotor air gap
5. Blade screwdriver

Fig. 8-12

After adjustment, tighten 2 screws and recheck air gap. Install ignitor, rotor and distributor cap.

Install distributor referring to p. 8-10.

[Ignitor assembly]

**NOTE:**

**Generator and ignitor can not be separated.**

**Inspection**

1. Disconnect center high-tension cord at distributor cap and be sure to ground it.
2. Remove distributor cap and rotor.
3. Check if signal rotor teeth are off generator pick up coil. If not, make it off by turning crankshaft.

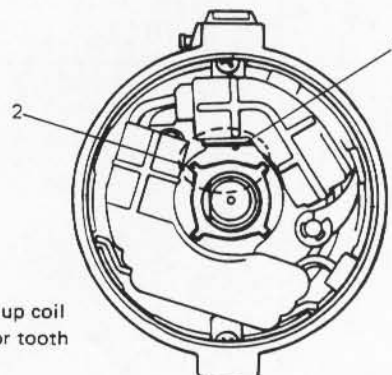

1. Pick up coil
2. Rotor tooth

Fig. 8-13

4. Connect voltmeter between negative terminal of ignition coil and engine ground, and confirm that battery voltage (12V) is applied to there.

5. Insert blade (-) screwdriver between signal rotor and generator pick up coil and then take it out repeatedly.

Voltmeter indicating battery voltage (12V) should fluctuate a little (about 0.5 – 1V) when the driver is inserted. If not, replace generator assembly as it can be deemed to be damaged.

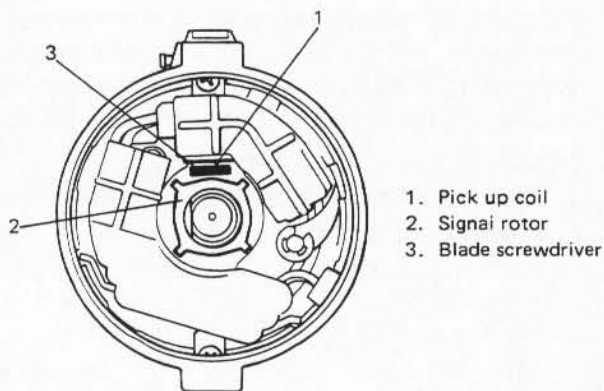

1. Pick up coil
2. Signal rotor
3. Blade screwdriver

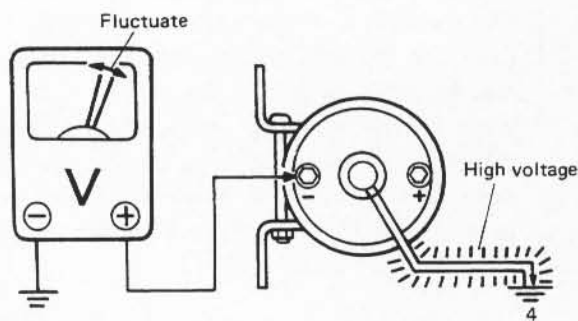

4. Engine ground

Fig. 8-14

## Removal

1. Disconnect negative cable at battery.  
Remove distributor, and then generator assembly (signal generator and ignitor).
2. Remove dust covers from generator assembly.

## Installation

1. Install dust covers to generator assembly (signal generator and ignitor).
2. Install signal generator and adjust air gap, refer to p. 8-6.

After adjustment, tighten 2 screws and recheck air gap. Install ignitor, rotor and distributor cap.

Install distributor referring to p. 8-10.

### WARNING:

- This inspection must be done in a well ventilated area.
- At step 1, be sure to ground high tension cord to the place away from carburetor or other fuel systems.
- While step 5 is performed, never touch the center high tension cord because high voltage is applied to the cord when the driver is inserted.

[Distributor driven gear]

Inspect gear teeth for wear, and see if the backlash is normal or not. Excessive backlash can be told by turning the shaft back and forth, with its driven gear in mesh with driving gear. Maladjusted ignition timing is often due to excessive tooth wear in this gearing and, in such a case, can be corrected by replacing driven gear.

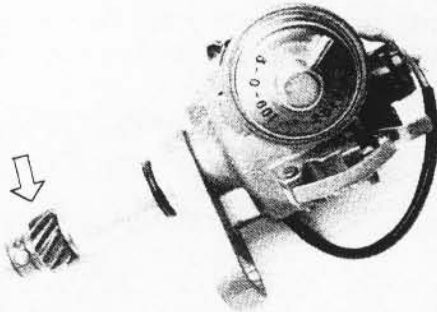

Fig. 8-18

To replace driven gear, grind off both caulked ends of driven gear set pin with grinder and drive it off. After fitting new gear, make sure to use a new pin and caulk its both ends.

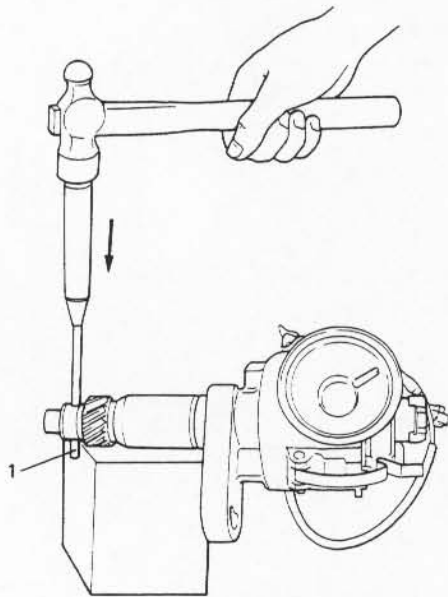

Fig. 8-19 1. Driven gear set pin

Ignition Timing

Ignition timing	10° BTDC at 850 ± 50 r/min
Ignition order	1 - 3 - 4 - 2

When checking and adjusting ignition timing, be sure to use timing light (09900-27301 or 09900-27311).

NOTE:

Prior to check and adjustment of ignition timing, make sure that head lights, heater fan, rear defogger (if equipped), and air conditioner (if equipped) are "OFF". If any one of these systems is "ON", idle up system operates and engine idle speed will be out of the specification.

[Checking]

1. Remove rubber plug from timing check window on the transmission case.
2. Start engine and warm it up to normal operating temperature.
3. After warming up, check to be sure that idle speed is within specification. If idle speed is out of specification, adjust it by turning idle speed adjusting screw of carburetor.
4. Connect timing light to high tension cord of No. 1 cylinder.
5. With engine running at specified idle speed, direct the timing light to timing check window. If 10° BTDC timing mark ① on flywheel appears aligned to timing match mark ②, ignition is properly timed.

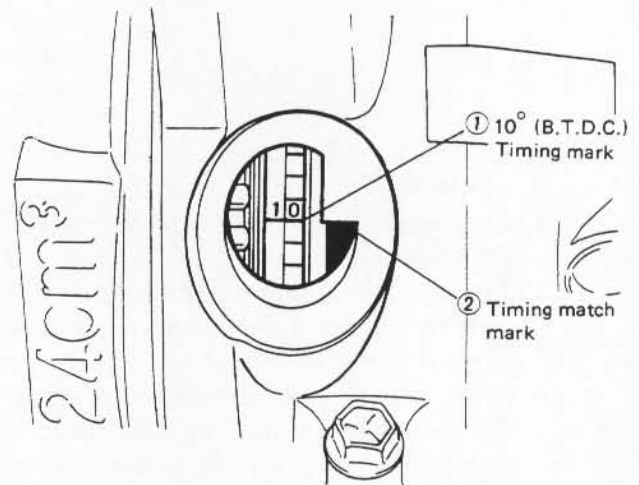

Fig. 8-20



### [Adjusting]

If the ignition timing is out of specification, adjust it.

Loosen distributor flange bolt and turn distributor housing in place to advance or retard timing.

Turning housing counterclockwise advances timing, and vice versa. After adjustment, tighten flange bolt and recheck timing.

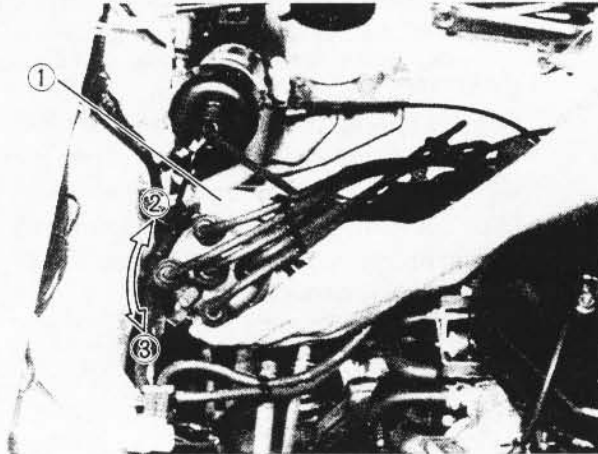

1. Distributor flange bolt
2. Timing is retarded
3. Timing is advanced

Fig. 8-21

Be sure to re-install check window rubber plug after making above checking and adjusting.

### [Checking centrifugal advancer]

After removing distributor cap, turn rotor clockwise by finger and release it.

Check that rotor returns smoothly counterclockwise by spring force.

If any defective, replace distributor.

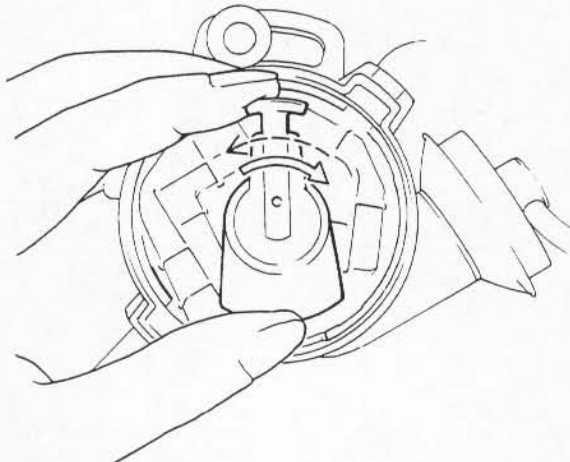
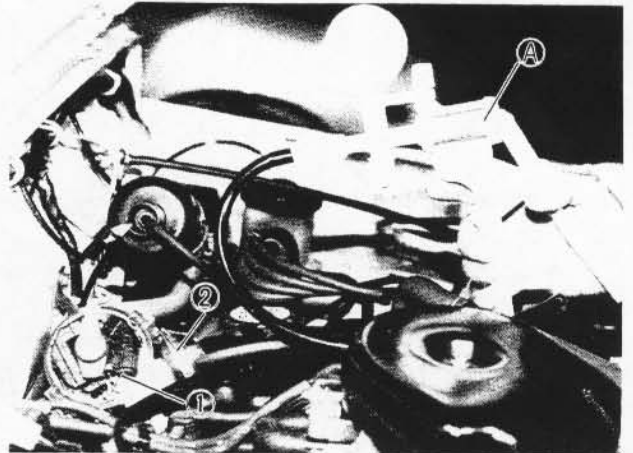

Fig. 8-22

### [Checking vacuum advancer]

Remove distributor cap.

Disconnect vacuum hose from vacuum controller, and connect vacuum pump gauge (09917-47910) to controller. Apply vacuum (about 400 mmHg). And then with pump stopped, check to ensure that vacuum pump gauge indicator remains at the same level, and release it. Check that generator base plate with generator moves smoothly. If plate does not move smoothly, replace defective parts.



- Ⓐ Vacuum pump gauge (09917-47910)
1. Generator base plate
  2. Vacuum controller

Fig. 8-23

### Distributor Drive Gear

#### NOTE:

When removing distributor gear case from cylinder head, engine oil in cylinder head may come out. So place waste or receiver under gear case when removing.

Inspect drive gear for wear.

Worn gear is likely to disturb ignition timing and therefore must be replaced.

Replacing worn-down drive gear is not enough. Inspect driven gear (a part of the distributor assembly), too, and replace it if badly worn down.

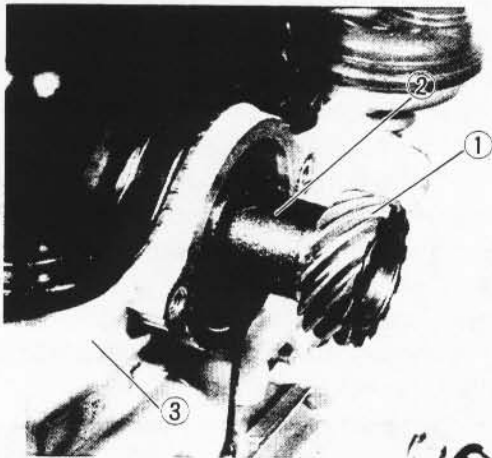

1. Distributor drive gear
2. Camshaft
3. Cylinder head

Fig. 8-24

[Important reminders for removal and installation]

- Before removing drive gear from camshaft, scribe a match mark on this shaft to root center line of drive gear as shown in Fig. 8-25 and, when mounting replacement drive gear, refer to this mark.
- When pressing replacement drive gear onto camshaft, be sure to position gear angularly as shown in Fig. 8-25. (align mark on camshaft scribed in removal with root center of drive gear)

**NOTE:**

There is no need to discriminate between two end faces of drive gear.

Distributor side view

1. Drive gear
2. Camshaft
3. Center line of  $\phi 5$  mm hole
4. Center line of root
5.  $\phi 5$  mm hole (Provided on pulley side of camshaft)
6. Scribed match mark
7.  $5^\circ$

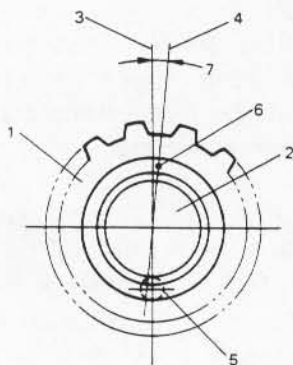

Fig. 8-25

- About 30 cc (1.01/1.05 US/Imp oz) of engine oil must be fed into distributor gear case after servicing this case, that is, removing and putting it back. Be sure to add this much oil before starting engine for the first time after servicing.

### 8-3. IMPORTANT REMINDERS FOR INSTALLATION

#### Distributor

When re-installing distributor, be sure to insert it into distributor gear case in the following sequence:

1. Turn over crankshaft in normal direction (clockwise as viewed from crankshaft pulley side) until specified timing mark ① on flywheel aligns with timing match mark ②.

**CAUTION:**

After aligning two marks, remove cylinder head cover to visually confirm that rocker arms are not riding on camshaft cams at No. 1 cylinder. If arms are found to be riding on cams, turn over crankshaft  $360^\circ$  to align two marks anew.

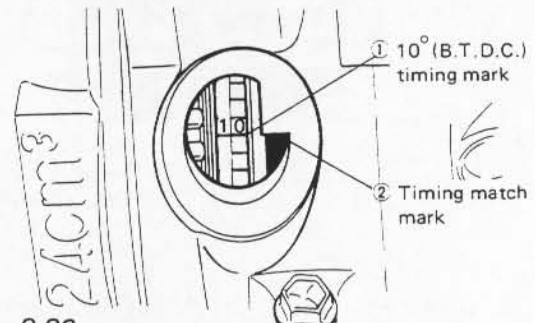
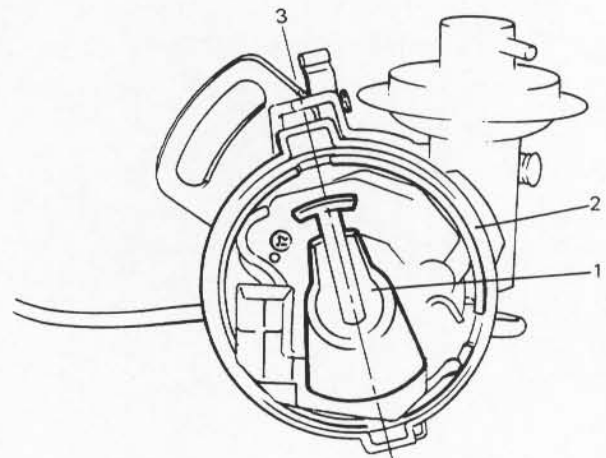

Fig. 8-26

2. Remove distributor cap, and turn rotor to make center of rotor align with cap clamp center on distributor housing as shown in figure.



1. Rotor
2. Housing
3. Center of rotor and clamp

Fig. 8-27

3. Insert distributor into gear case in such a way that center of distributor flange will coincide with the distributor mounting screw hole provided in distributor gear case. When distributor is inserted properly, position of distributor rotor becomes as shown in figure. Secure distributor in place tentatively by making mounting screw finger-tight.

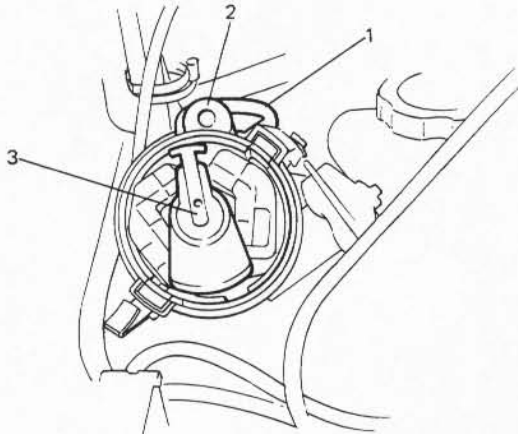

*Fig. 8-28*

- |                       |          |
|-----------------------|----------|
| 1. Distributor flange | 3. Rotor |
| 2. Mounting screw     |          |

4. Install cap gasket and distributor cap to distributor.  
Hook 2 clamps securely.
5. Distribute cords as shown in figure. Securely connect cords to distributor cap terminals and spark plugs.

**NOTE:**

Make sure to clamp high tension cords so that they do not contact other parts.

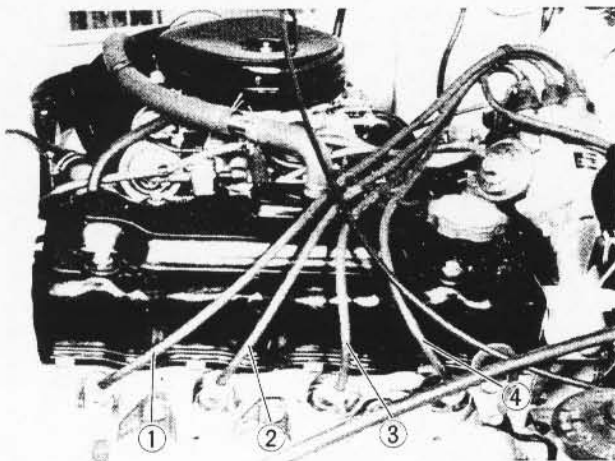

- |                   |                   |
|-------------------|-------------------|
| 1. No. 1 cylinder | 3. No. 3 cylinder |
| 2. No. 2 cylinder | 4. No. 4 cylinder |

*Fig. 8-29 High tension cords distribution*

6. Connect vacuum hose to vacuum controller, and coupler of lead wires.
7. Connect negative cable at battery.
8. Start engine and adjust ignition timing by using timing light as previously outlined.  
After adjustment, tighten distributor flange bolt.