

COOLING SYSTEM ** **

DESCRIPTION

This engine utilizes a pressurized forced circulation cooling system which includes a thermostat equipped with a bypass valve mounted on the inlet side.

OPERATION

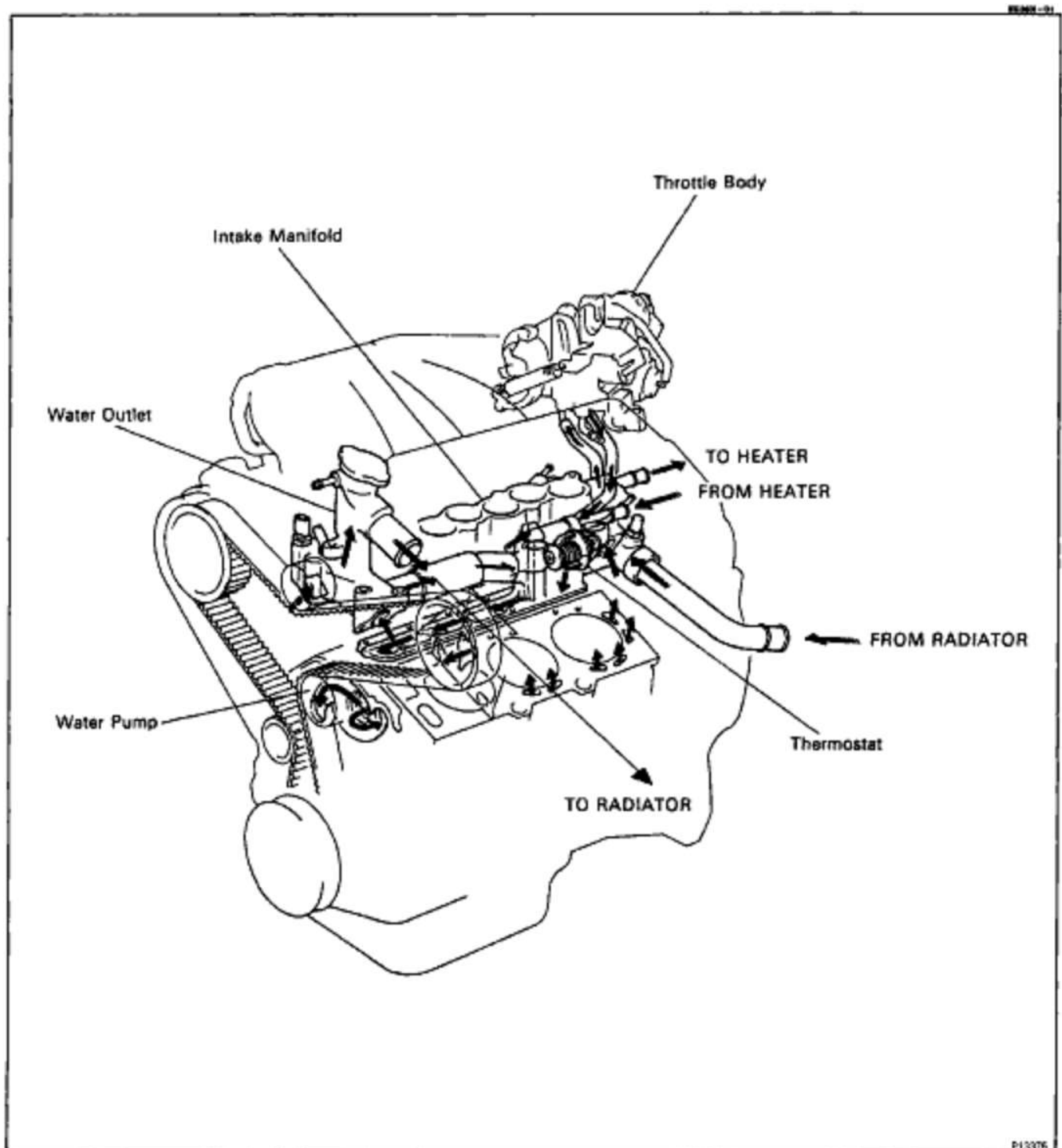

EG2-314

1MZ-FE ENGINE - COOLING SYSTEM

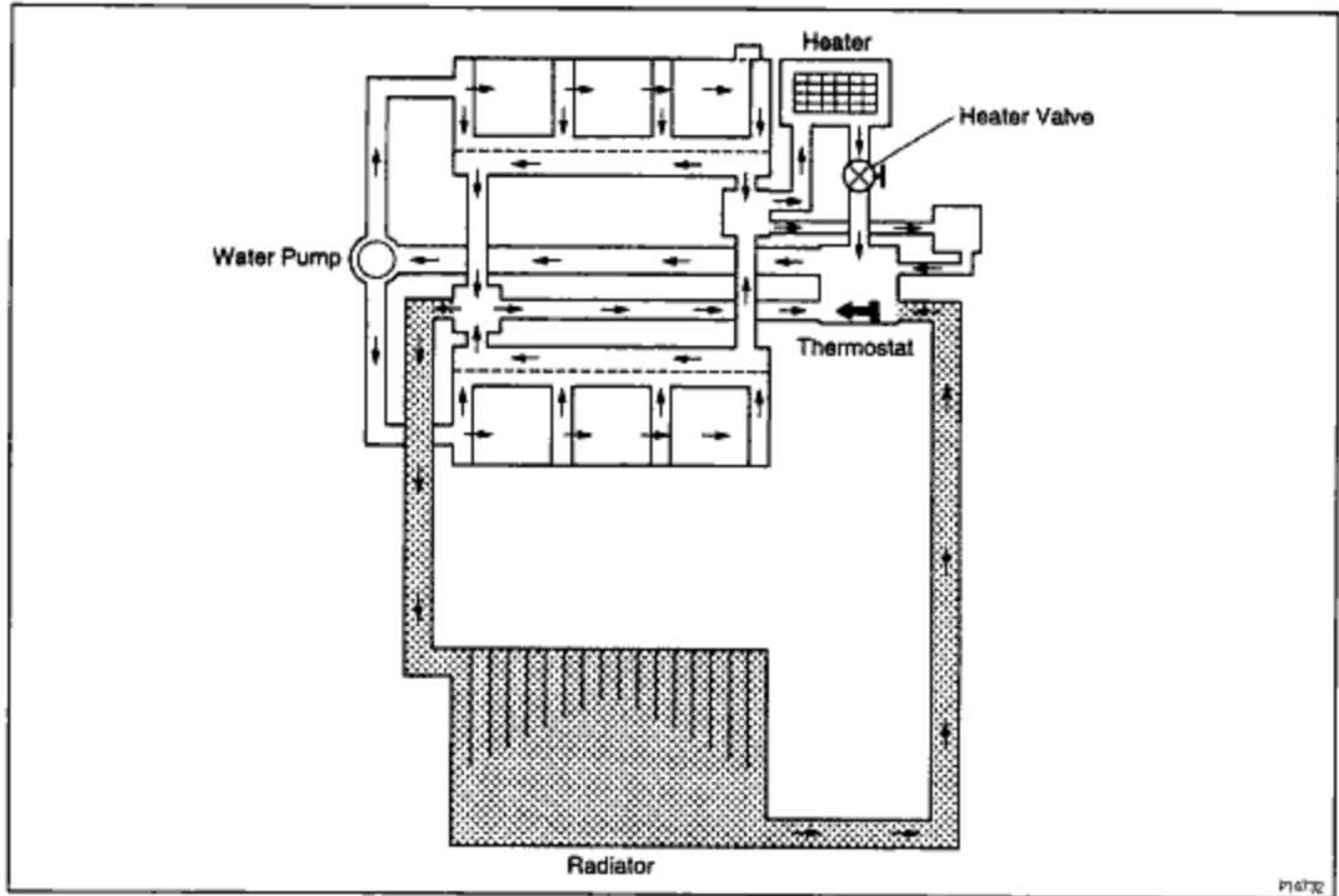

The cooling system is composed of the water jacket (inside the cylinder block and cylinder head), radiator, water pump, thermostat, electronically controlled hydraulic cooling fan, hoses and other components.

Coolant which is heated in the water jacket is pumped to the radiator, through which a cooling fan blows air to cool the coolant as it passes through. Coolant which has been cooled is then sent back to the engine by the water pump, where it cools the engine.

The water jacket is a network of channels in the shell of the cylinder block and cylinder head through which coolant passes. It is designed to provide adequate cooling of the cylinders and combustion chambers which become heated during engine operation.

RADIATOR

The radiator, mounted in the front of the vehicle, performs the function of cooling the coolant which has passed through the water jacket and become hot. The radiator consists of an upper tank and lower tank, and a core which connects the two tanks. The upper tank contains the inlet for coolant from the water jacket. The lower tank has an outlet and drain plug for the coolant. The core contains many tubes through which coolant flows from the upper tank to the lower tank as well as cooling fins which radiate heat away from the coolant in the tubes.

The air sucked through the radiator by the cooling fan, as well as the wind generated by the vehicle's travel, passes through the radiator, cooling the coolant. Models with an automatic transmission include an automatic transmission fluid cooler built into the lower tank of the radiator. A cooling fan is mounted behind the radiator to assist the flow of air through the radiator. When the coolant temperature is low, the fan operates slowly to help the engine warm up, and when the coolant temperature becomes high, the fan speed is increased to provide the air flow required for cooling.

RADIATOR CAP (on water outlet)

The radiator cap is a pressure-type cap which seals the engine coolant circuit and the resulting pressurization of the engine as the coolant expands. The pressurization prevents the coolant from boiling even when the coolant temperature exceeds 100₂C (212₂F). A relief valve (pressurization valve) and a vacuum valve (negative pressure valve) are built into the radiator cap. The relief valve opens and lets steam escape through the overflow pipe when the pressure generated inside the cooling system exceeds the limit (coolant temperature: 110 – 120₂C (230 – 248₂F), pressure: 83 – 113 kPa (0.85 – 1.15 kgf/cm², 12.1 – 16.4 psi). The vacuum valve opens to alleviate the vacuum which develops in the coolant system after the engine is stopped and the coolant temperature drops. The valve's opening allows the coolant in the reservoir tank to return to the cooling system.

RESERVOIR TANK

The reservoir tank is used to catch coolant which overflows the cooling system as a result of volumetric expansion when the coolant is heated. The coolant in the reservoir tank returns to the water outlet when the coolant temperature drops thus keeping the radiator full at all times and avoiding needless coolant loss. Check the reservoir tank level to learn if the coolant needs to be replenished.

WATER PUMP

The water pump is used for forced circulation of coolant through the cooling system. It is mounted on the front of the cylinder block and driven by a timing belt.

THERMOSTAT









The thermostat has a wax type bypass valve and is mounted in the water inlet housing. The thermostat includes a type of automatic valve operated by fluctuations in the coolant temperature. This valve closes when the coolant temperature drops, preventing the circulation of coolant through the engine and thus permitting the engine to warm up rapidly. The valve opens when the coolant temperature has risen, allowing the circulation of coolant. Wax inside the thermostat expands when heated and contracts when cooled. Heating the wax thus generates pressure which overpowers the force of the spring which keeps the valve closed, thus opening the valve. When the wax cools, its contraction allows the force of the spring to take effect once more, closing the valve. The thermostat in this engine operates at a temperature of 82₂ C (180₂ F).

ELECTRONICALLY CONTROLLED HYDRAULIC COOLING FAN (See page [EG2-346](#))



EG2-316

1MZ-FE ENGINE - FE ENGINE - COOLING SYSTEM

PREPARATION**SST (SPECIAL SERVICE TOOLS)**

	09230-01010 Radiator Service Tool Set	
	09249-63010 Torque Wrench Adaptor	RH camshaft timing pulley
	09620-30010 Steering Gear Box Replacer Set	
	(09627-30010) Steering Sector Shaft Bushing Replacer	Hydraulic motor oil seal
	(09631-00020) Handle	Hydraulic motor oil seal
	09843-18020 Diagnosis Check Wire	
	09960-10010 Variable Pin Wrench Set	
	(09962-01000) Variable Pin Wrench Arm Assy	

RECOMMENDED TOOLS

	09025-00010 Smell Torque Wrench	For measuring preload
	09082-00050 TOYOTA Electrical Tester Set	
	09905-00013 Snap Ring Pliers	

1MZ-FE ENGINE - COOLING SYSTEM

EQUIPMENT

9000-01

Caliper gauge	
Heater	ECT sensor
Precision straight edge	
Radiator cap tester	
Micrometer	
Thermometer	ECT sensor
Torque wrench	
Vernier calipers	

LUBRICANT

9007-01

Item	Capacity	Classification
Power steering fluid (Total) (Hydraulic cooling fan fluid)	2.2 liters (2.3 US qts, 1.9 Imp. qts)	ATF DEXRON ₂ II

COOLANT

9000-01

Item	Capacity	Classification
Engine coolant	8.7 liters (9.2 US qts, 7.7 Imp. qts)	Ethylene-glycol base

EG2-318

1MZ-FE ENGINE - COOLING SYSTEM

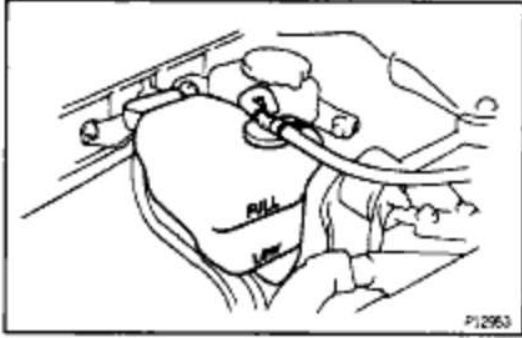

COOLANT CHECK

1. CHECK ENGINE COOLANT LEVEL AT RESERVOIR TANK

The engine coolant level should be between the "LOW" and "FULL" lines.

If low, check for leaks and add engine coolant up to the "FULL" line.

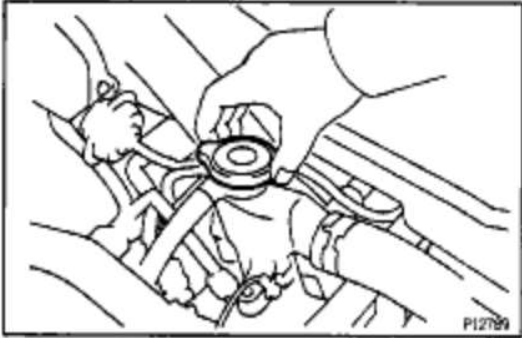

2. CHECK ENGINE COOLANT QUALITY

(a) Remove the radiator cap from the water outlet.

CAUTION: To avoid the danger of being burned, do not remove the radiator cap while the engine and radiator are still hot, as fluid and steam can be blown out under pressure.

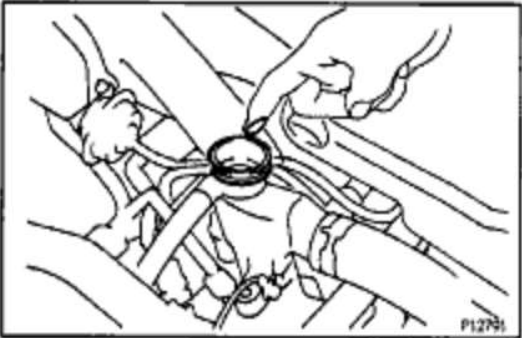

(b) There should not be any excessive deposits of rust or scale around the radiator cap or water outlet filler hole, and the coolant should be free from oil.

If excessively dirty, clean the coolant passages and replace the coolant.

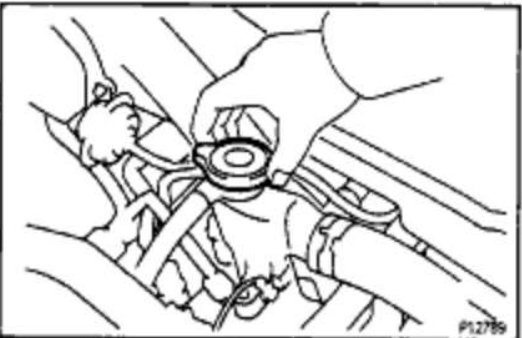

(c) Reinstall the radiator cap.



COOLANT REPLACEMENT

1. DRAIN ENGINE COOLANT

DRNT-04

(a) Remove the radiator cap from the water outlet.

CAUTION: To avoid the danger of being burned, do not remove the radiator cap while the engine and radiator are still hot, as fluid and steam can be blown out under pressure.

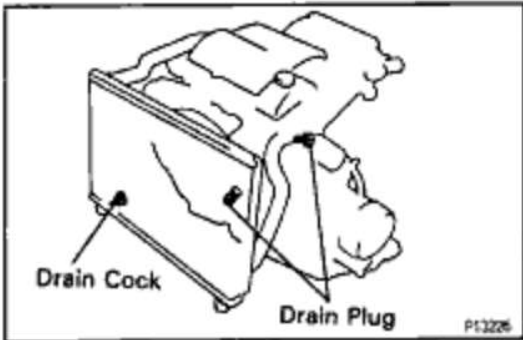

(b) Loosen the drain cock (for the radiator) and drain plugs (for the engine), and drain the coolant.

(c) Close the drain plugs and cock.

Torque:

7 N-m (70 kgf-cm, 61 in.-lbf) for RH drain plug

13 N-m (130 kgf-cm, 9 ft.-lbf) for LH drain plug

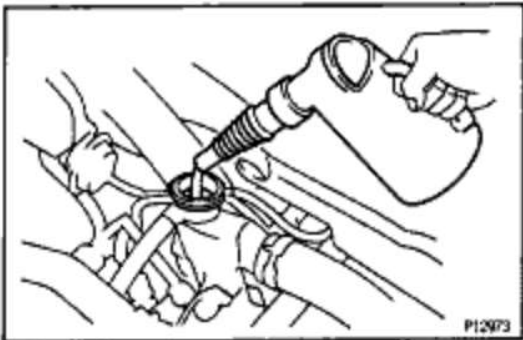

2. FILL ENGINE COOLANT

(a) Slowly fill the system with coolant.

- Use a good brand of ethylene-glycol base coolant and mix it according to the manufacturer's directions.
- Using coolant which includes more than 50% ethylene-glycol (but not more than 70 96) is recommended.

NOTICE:

- Do not use an alcohol type coolant.
- The coolant should be mixed with demineralized water or distilled water.

Capacity:

8.7 liters (9.2 US qts. 7.7 Imp. qts)



(b) Install the radiator cap.

(c) Start the engine, and bleed the cooling system.

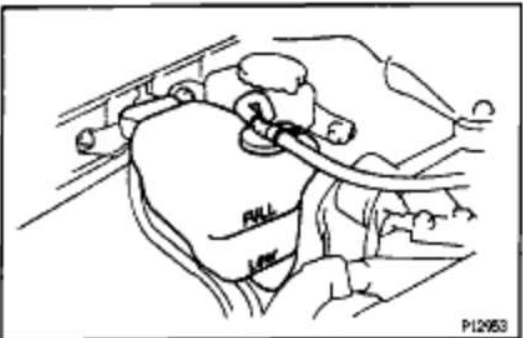

(d) If necessary, refill coolant into the reservoir tank up to the "FULL" line.

3. CHECK ENGINE COOLANT FOR LEAKS

EG2-320

1MZ-FE ENGINE - COOLING SYSTEM

WATER PUMP COMPONENTS FOR REMOVAL AND INSTALLATION

RMW-88

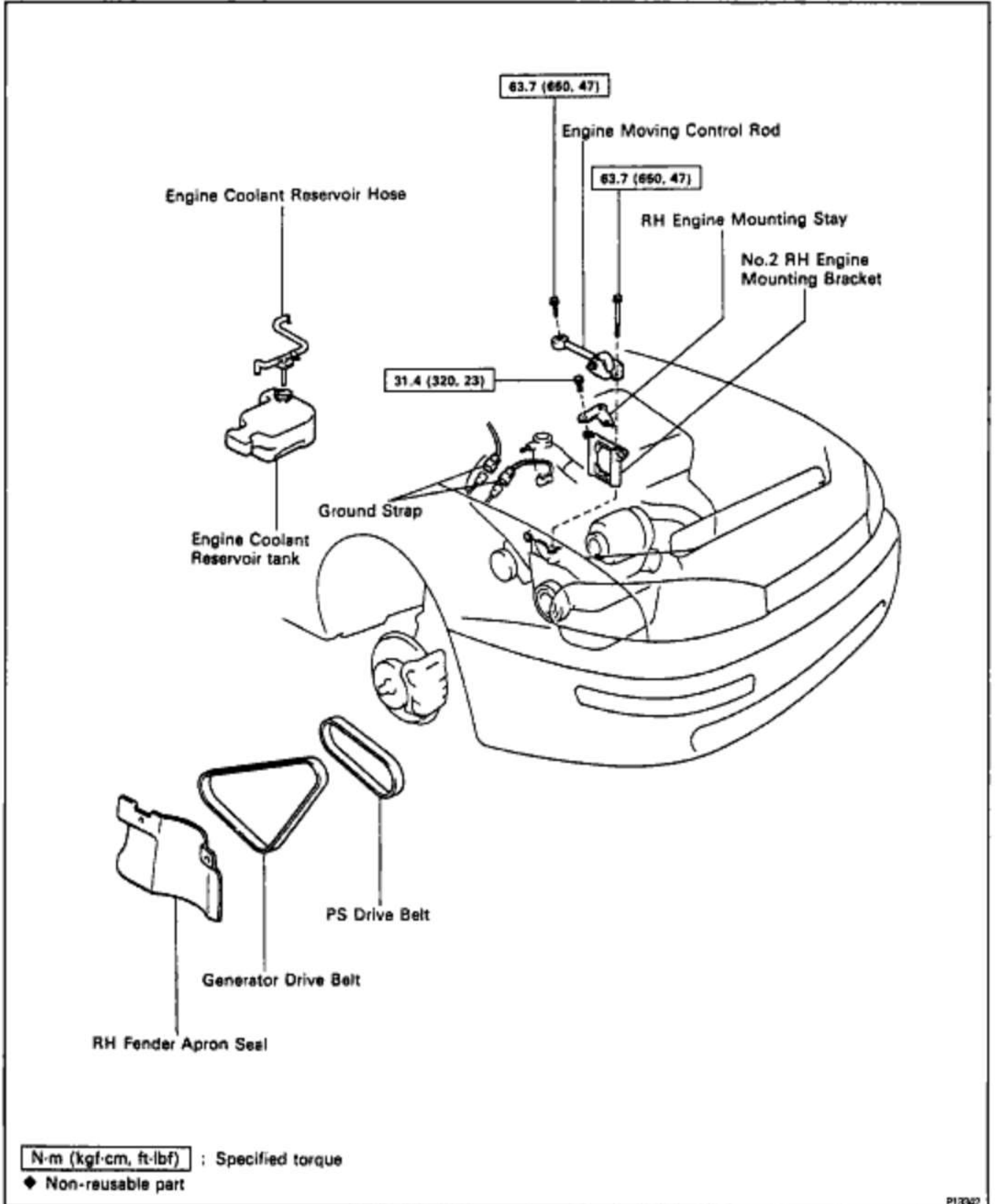

1MZ-FE ENGINE - COOLING SYSTEM

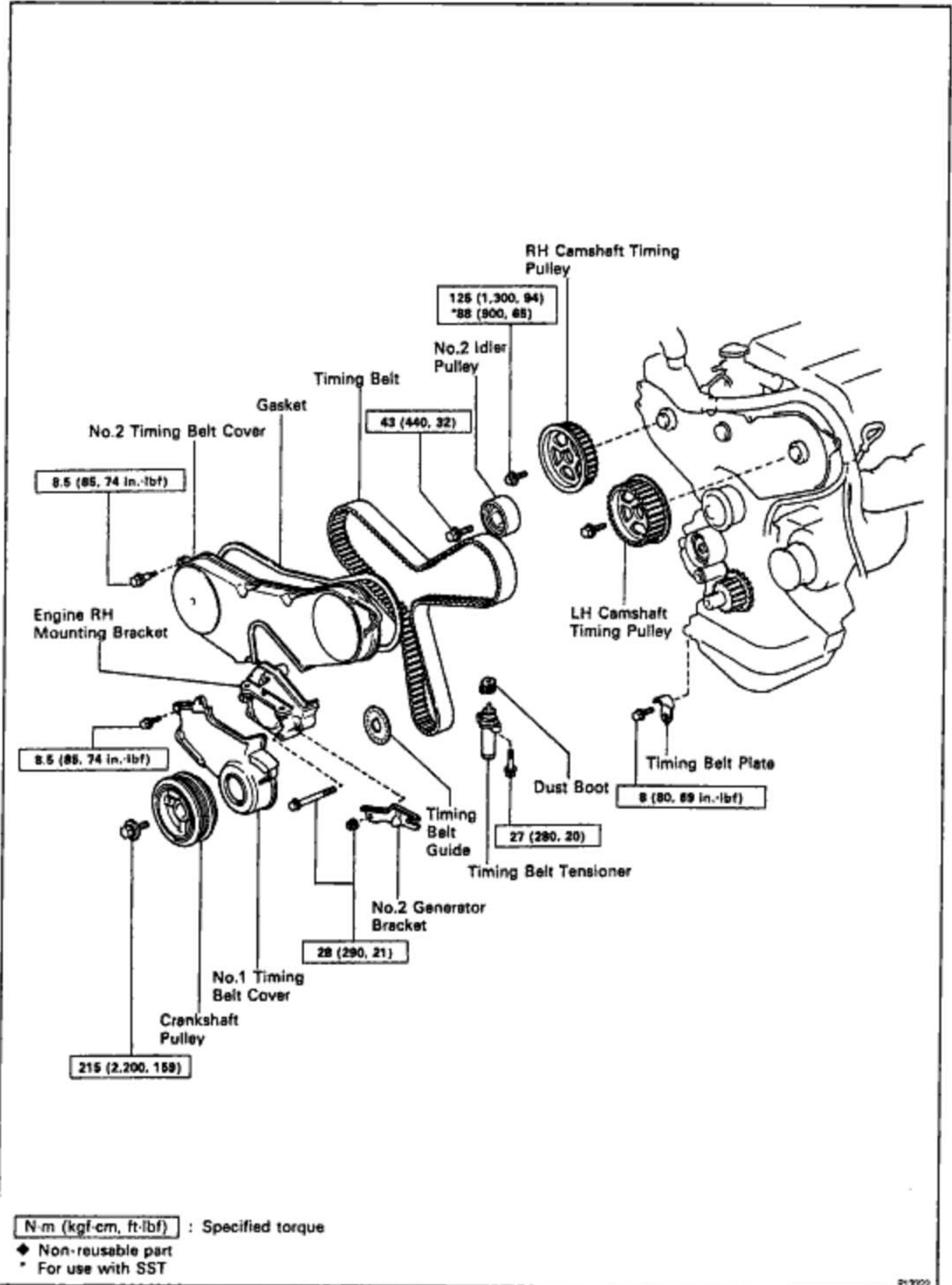

P1302

EG2-322

1MZ-FE ENGINE - COOLING SYSTEM

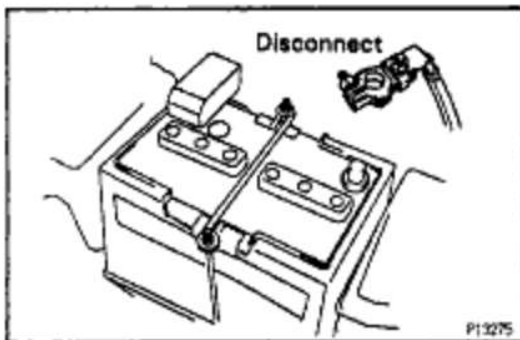
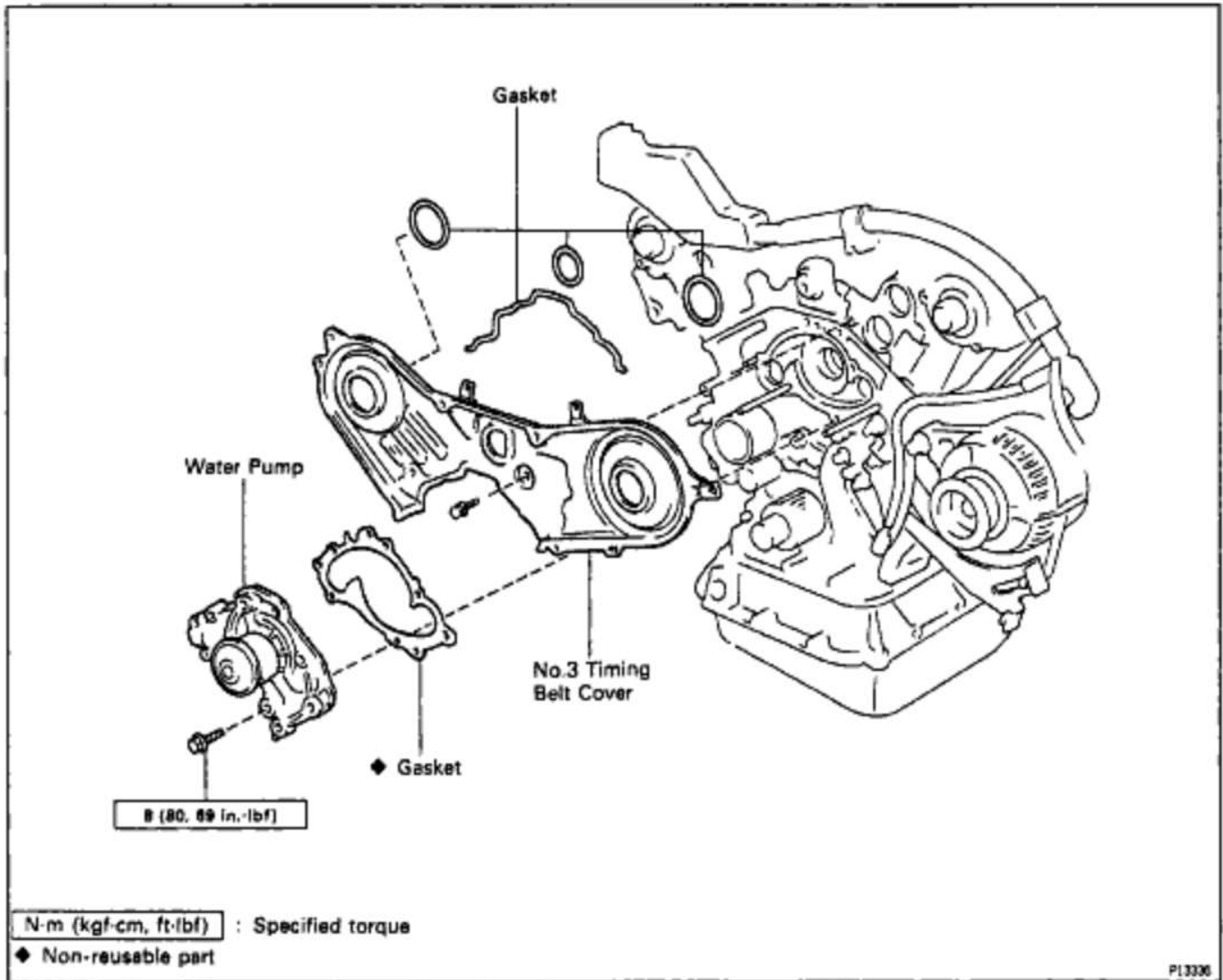

WATER PUMP REMOVAL

(See Components for Removal and Installation)

1. DISCONNECT NEGATIVE (-) TERMINAL CABLE FROM BATTERY

CAUTION: Work must be started after 90 seconds from the time the ignition switch is turned to the 'LOCK' position and the negative (-) terminal cable is disconnected from the battery.

2. DRAIN ENGINE COOLANT

3. REMOVE TIMING BELT

(See steps 2 to 20 on pages [EG2-41](#) to [45](#))

1MZ-FE ENGINE - COOLING SYSTEM

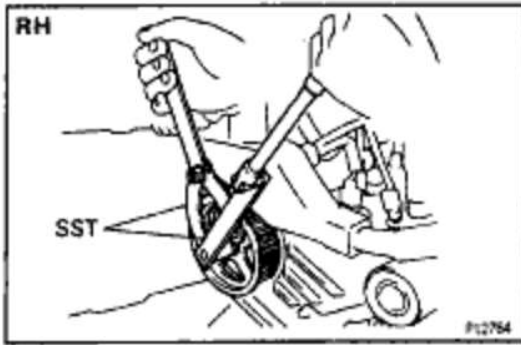
**4. REMOVE CAMSHAFT TIMING PULLEYS**

(a) Using SST, remove the bolt and RH timing pulley.
SST 09249-63010, 09960-10010 (09962-01000)

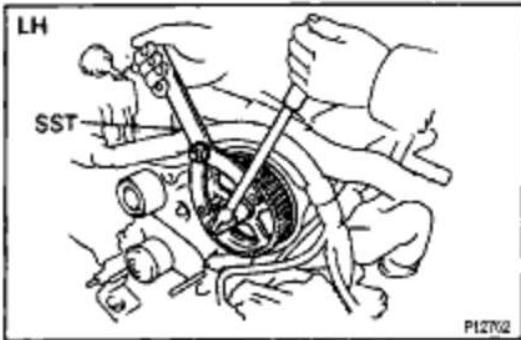

(b) Using SST, remove the bolt and LH timing pulley.
SST 09960-01000 (09962-01000)

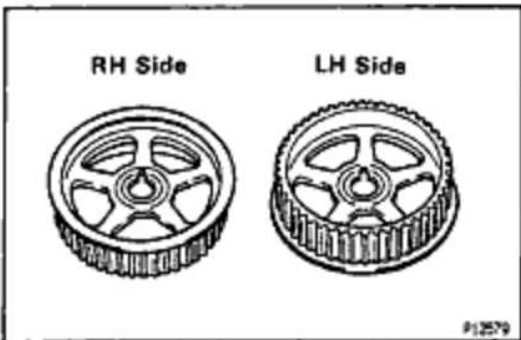

HINT: Arrange the camshaft timing pulleys (RH and LH sides).

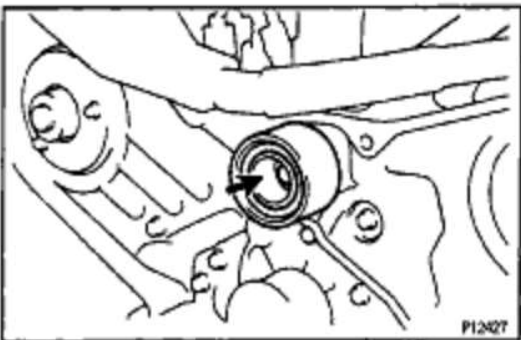
**5. REMOVE NO.2 IDLER PULLEY**

Remove the bolt and idler pulley.

EG2-324

1MZ-FE ENGINE - COOLING SYSTEM

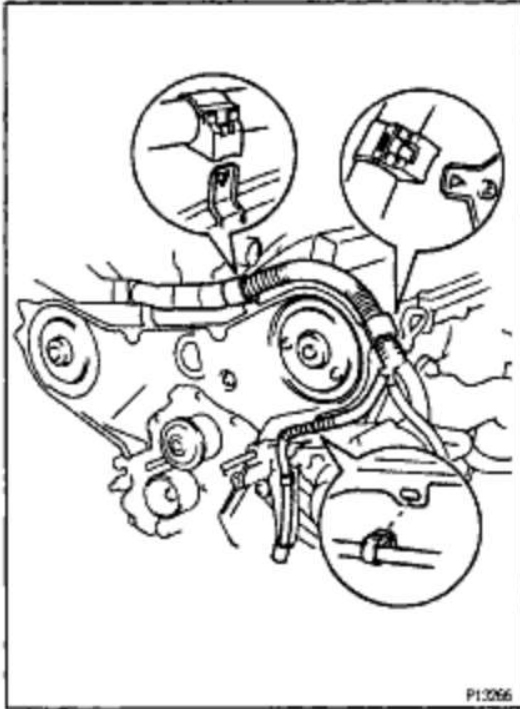
**6. DISCONNECT ENGINE WIRE**

Disconnect the 3 clamps and engine wire from the No. 3 timing belt cover.

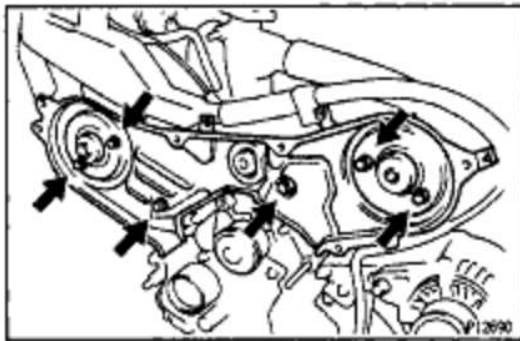
**7. REMOVE NO.3 TIMING BELT COVER**

Remove the 6 bolts and belt cover.

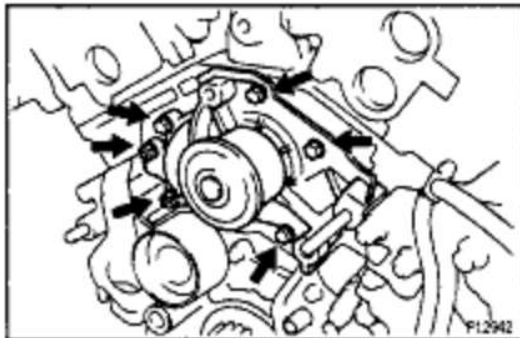
**8. REMOVE WATER PUMP**

Remove the 4 bolts, 2 nuts, water pump and gasket.

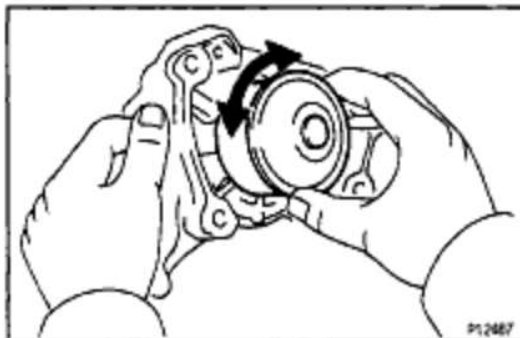
**WATER PUMP INSPECTION****INSPECT WATER PUMP**

Turn the pulley and check that the water pump bearing moves smoothly and quietly.

8888-01

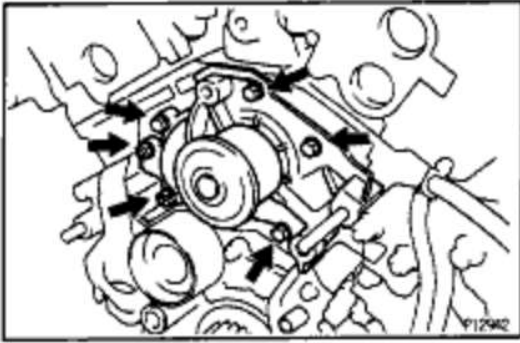

WATER PUMP INSTALLATION

(See Components for Removal and Installation)

1. INSTALL WATER PUMP

Install a new gasket and the water pump with the 4 bolts and 2 nuts.

Torque: 8 N-m (80 kgf-cm, 69 in.-lbf)

NOTICE: Do not get oil on the gasket.

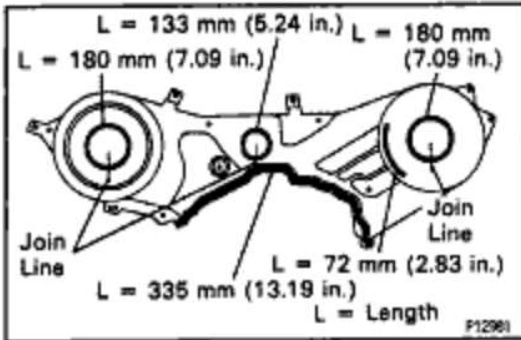

2. INSTALL NO.3 TIMING BELT COVER .

(a) Check that the timing belt cover gaskets have no cracks or peeling, etc.

If the gaskets do have cracks or peeling, etc., replace them using the following steps.

(1) Using a screwdriver and gasket scraper, remove all the old gasket material.

(2) Thoroughly clean all components to remove all the loose material.

(3) Remove the backing paper from a new gasket and install the gasket evenly to the part of the belt cover shaded black in the illustration.

NOTICE: When joining gaskets, do not leave a gap between them. Cut off any excess gasket.

(4) After installing the gasket, press down on it so that the adhesive firmly sticks to the belt cover.

(b) Install new gaskets to the No.3 belt cover.

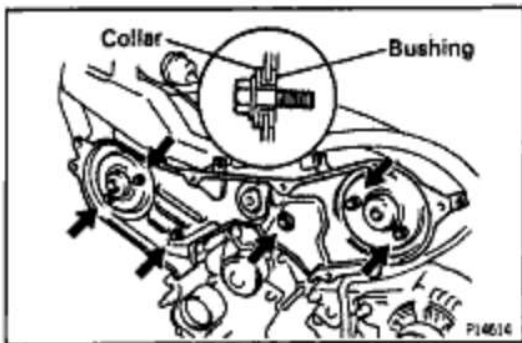

(c) Install the belt cover with the 6 bolts.

Torque: 8.5 N-m (85 kgf-cm, 74 in.-lbf)

EG2-326

1MZ-FE ENGINE - FE ENGINE - COOLING SYSTEM

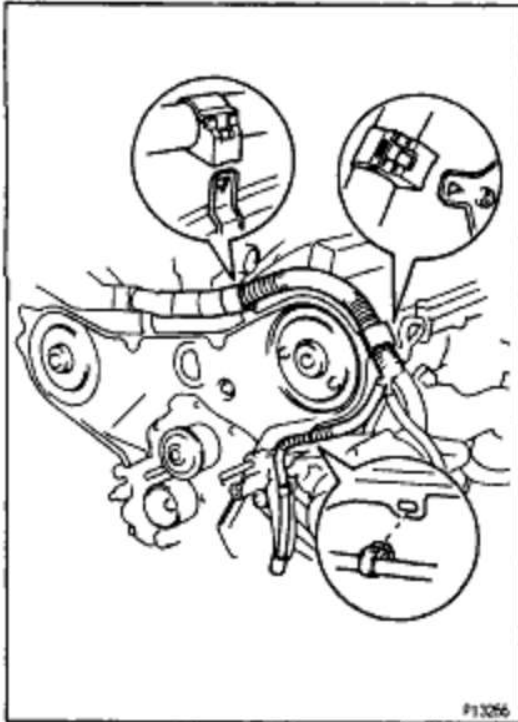
**3. CONNECT ENGINE WIRE**

Connect the engine wire with the 3 clamps.

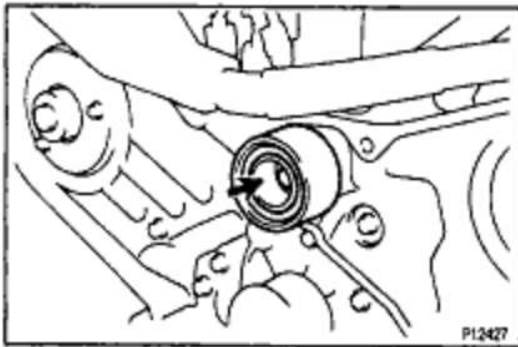
**4. INSTALL NO.2 IDLER PULLEY**

(a) Install the idler pulley with the bolt.

Torque: 43 N-m (440 kgf-cm, 32 ft-lbf)

(b) Check that the idler pulley moves smoothly.

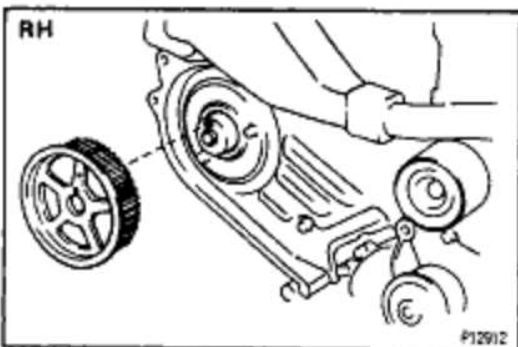
**5. INSTALL RH CAMSHAFT TIMING PULLEY**

(a) Install the timing pulley, facing the flange side outward.

(b) Align the knock pin hole of the camshaft with the knock pin groove of the timing pulley as shown.

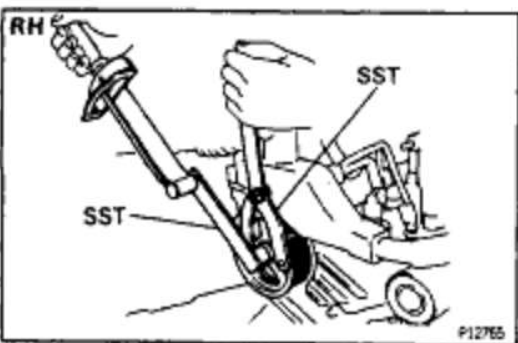

(c) Using SST, install and torque the bolt.

SST 09249-63010, 09960-10010 (09962-01000)

Torque: 88 N-m (900 kgf-cm, 65 ft-lbf)

HINT: Use a torque wrench with a fulcrum length of 340 mm (13.39 in.)

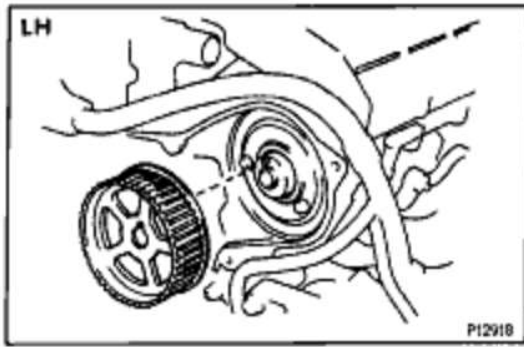

6. INSTALL LH CAMSHAFT TIMING PULLEY

- (a) Install the timing pulley, facing the flange side inward.
- (b) Align the knock pin hole of the camshaft with the knock pin groove of the timing pulley as shown.

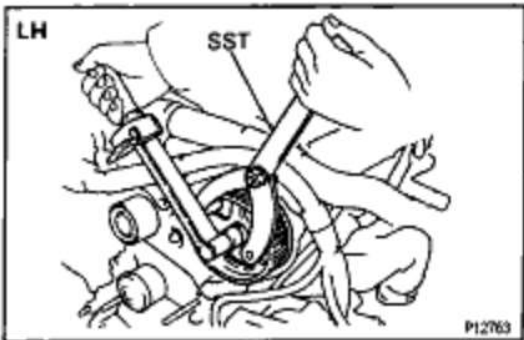

- (c) Using SST, install and torque the bolt.

SST 09960-10010 (09962-01000)

Torque: 125 N-m (1,300 kgf-cm, 94 ft-lbf)

7. INSTALL TIMING BELT

(See steps 6 to 27 on pages [EG2-51](#) to 56)

8. FILL WITH ENGINE COOLANT

Capacity:

8.7 liters (9.2 US qts, 7.7 Imp. qts)

9. CONNECT NEGATIVE (-) TERMINAL CABLE TO BATTERY

10. START ENGINE AND CHECK FOR LEAKS

11. RECHECK ENGINE COOLANT LEVEL

EG2-328

1MZ-FE ENGINE - COOLING SYSTEM

THERMOSTAT COMPONENTS FOR REMOVAL AND INSTALLATION

MEG-02

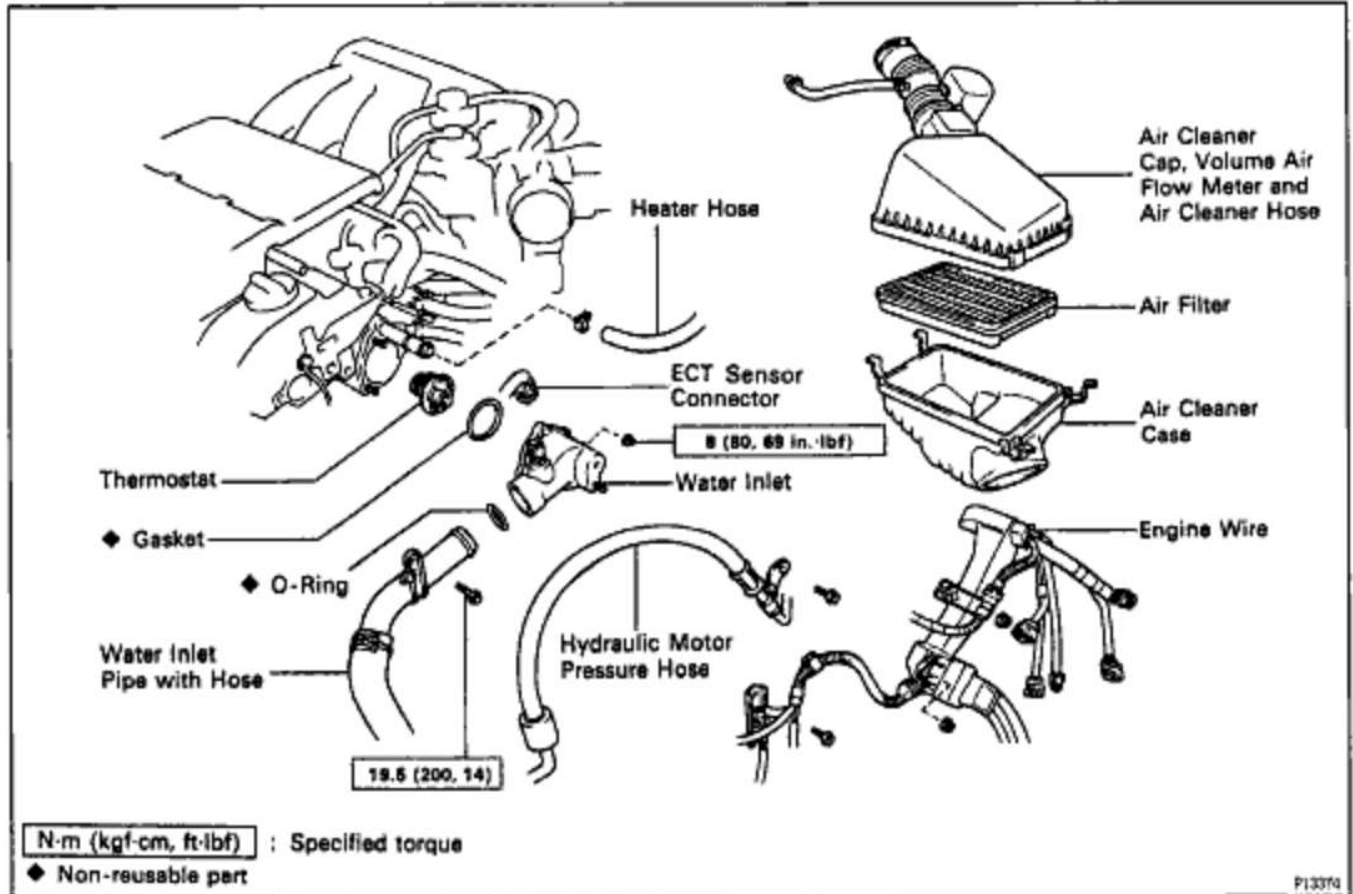

THERMOSTAT REMOVAL

MEG-01

(See Components for Removal and Installation)

HINT: Removal of the thermostat would have an adverse effect, causing a lowering of cooling efficiency. Do not remove the thermostat, even if the engine tends to overheat.

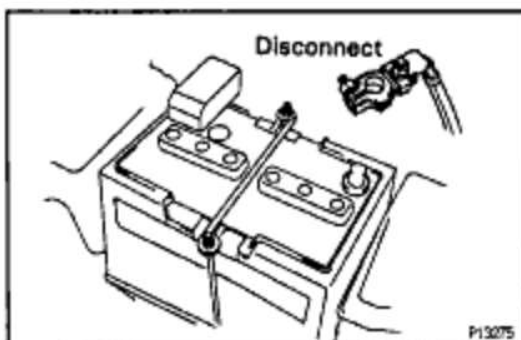

1. DISCONNECT NEGATIVE (-) TERMINAL CABLE FROM BATTERY

CAUTION: Work must be started after 90 seconds from the time the Ignition switch is turned to the "LOCK" position and the negative (-) terminal cable is disconnected from the battery.

2. DRAIN ENGINE COOLANT

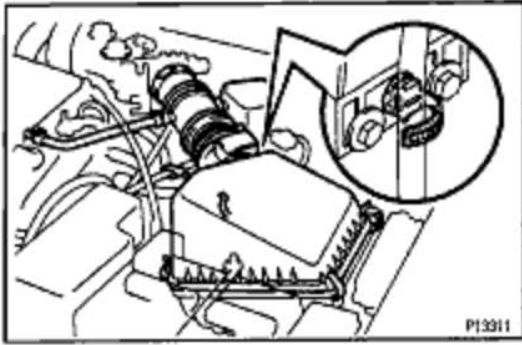

3. REMOVE AIR CLEANER CAP, VOLUME AIR FLOW METER AND AIR CLEANER HOSE

- (a) Disconnect the volume air flow meter connector and wire clamp.
- (b) Disconnect the accelerator cable clamp.
- (c) Disconnect the PCV hose.
- (d) Loosen the air cleaner hose clamp bolt.
- (e) Disconnect the 4 air cleaner cap clips.
- (f) Remove the air cleaner cap and volume air flow meter together with the air cleaner hose.

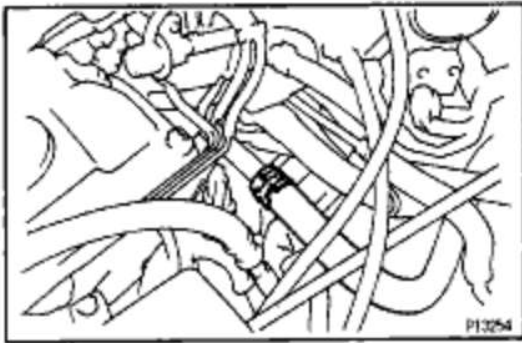

4. DISCONNECT HEATER HOSE



5. DISCONNECT PRESSURE HOSE OF HYDRAULIC MOTOR

Remove the bolt and disconnect the pressure hose from the water inlet.

6. DISCONNECT ENGINE WIRE

Remove the 2 nuts and disconnect the engine wire from the water inlet and cylinder head.

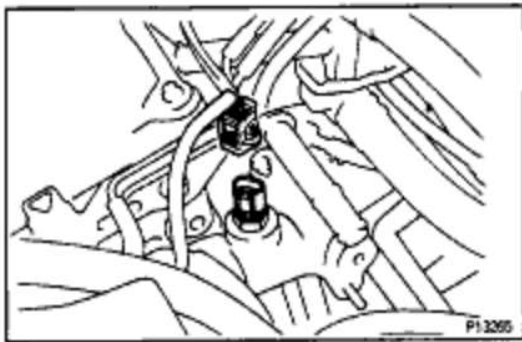

7. DISCONNECT ENGINE COOLANT TEMPERATURE (ECT) SENSOR CONNECTOR

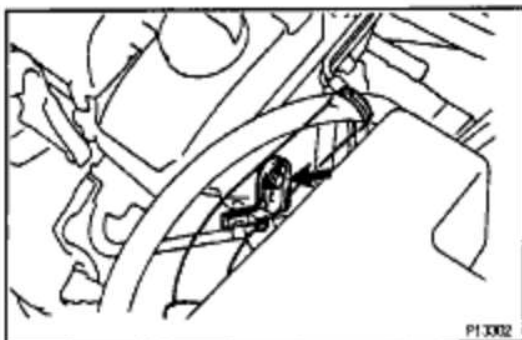

8. DISCONNECT WATER INLET PIPE

- (a) Remove the bolt holding the water inlet pipe to the cylinder head.
- (b) Disconnect the water inlet pipe and remove the O-ring.

EG2-330

1MZ-FE ENGINE - COOLING SYSTEM

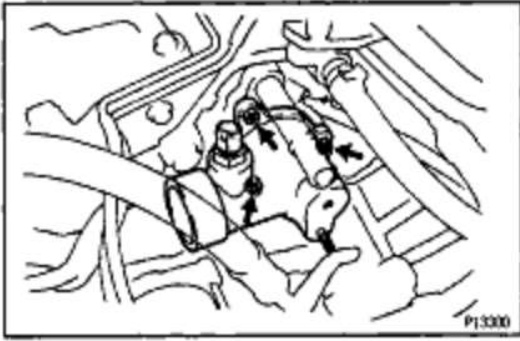
**8. REMOVE WATER INLET**

Remove the 3 nuts and water inlet from the water inlet housing.

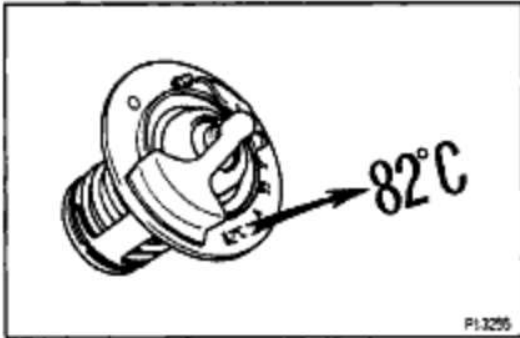
10. REMOVE THERMOSTAT AND GASKET**THERMOSTAT INSPECTION****INSPECT THERMOSTAT**

HINT: The thermostat is numbered with the valve opening temperature.

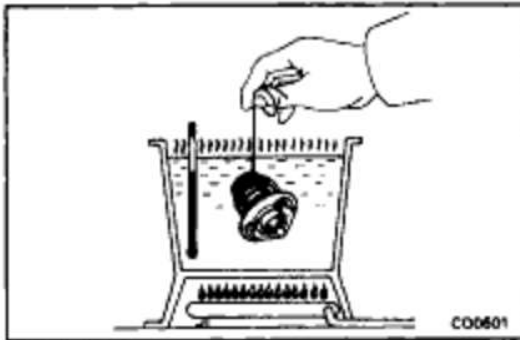

(a) Immerse the thermostat in water and gradually heat the water.

(b) Check the valve opening temperature.

Valve opening temperature:

80 – 84 °C (176 – 183 °F)

If the valve opening temperature is not as specified, replace the thermostat.

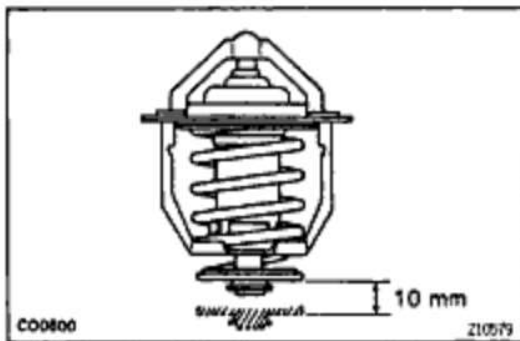

(c) Check the valve lift.

Valve lift:

10.0 mm (0.394 In.) or more at 95° C (203₂ F)

If the valve lift is not as specified, replace the thermostat.

(d) Check that the valve spring is tight when the thermostat is fully closed.

If not closed, replace the thermostat.

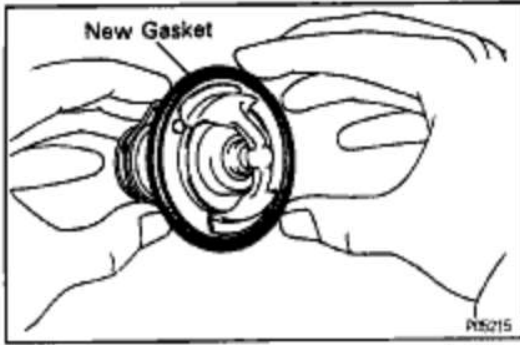

THERMOSTAT INSTALLATION

(See Components for Removal and Installation)

1. PLACE THERMOSTAT IN WATER PUMP

(a) Install a new gasket to the thermostat.

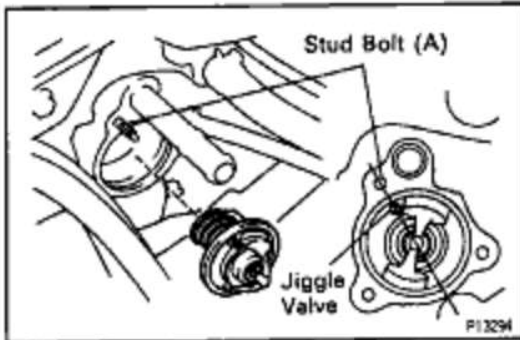

(b) Align the jiggle valve of the thermostat with stud bolt (A), and insert the thermostat in the water inlet housing.

HINT: The jiggle valve may be set within 30° of either side of the prescribed position.

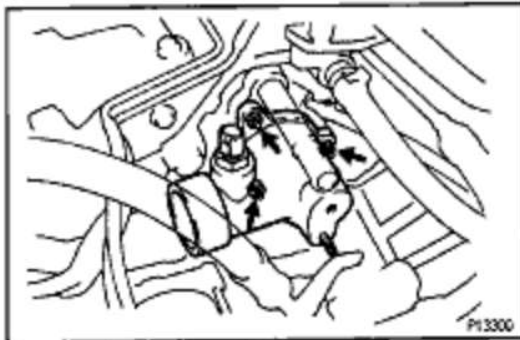

2. INSTALL WATER INLET

Install the water inlet with the 3 nuts.

Torque: 8 N-m (80 kgf-cm, 69 in.-lbf)

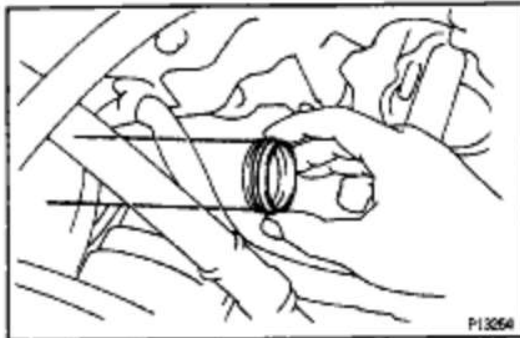

3. INSTALL WATER INLET PIPE

(a) Install a new O-ring to the water inlet pipe.

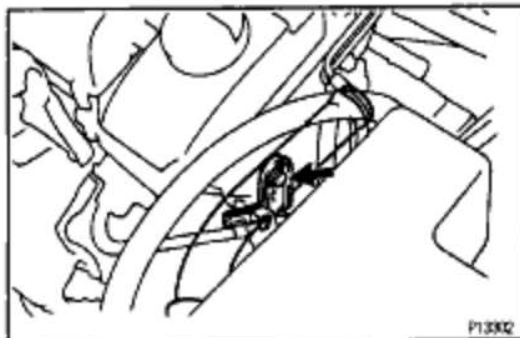

(b) Apply soapy water to the O-ring.

(c) Connect the water inlet pipe to the water inlet.

(d) Install the bolt holding the water inlet pipe to the cylinder head.

Torque: 19.5 N-m (200 kgf-cm, 14 ft-lbf)

EG2-332

1MZ-FE ENGINE - COOLING SYSTEM

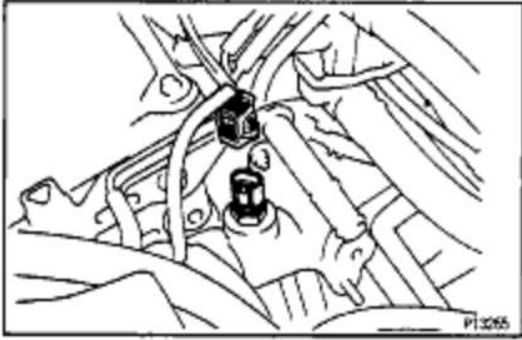

4. CONNECT ENGINE COOLANT TEMPERATURE SENSOR (ECT) CONNECTOR



5. CONNECT ENGINE WIRE

Connect the engine wire to the water inlet and cylinder head with the 2 nuts.

6. CONNECT HYDRAULIC MOTOR PRESSURE HOSE

Connect the pressure hose with the bolt.

Torque: 8 N-m (80 kgf-cm, 69 in.-lbf)

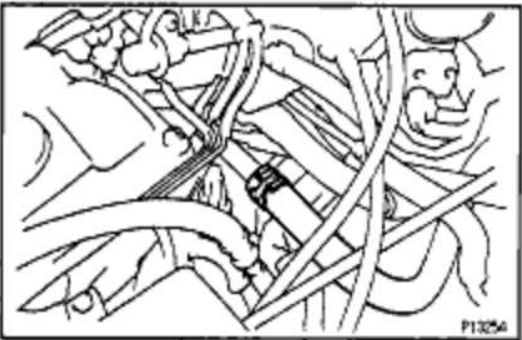

7. CONNECT HEATER HOSE

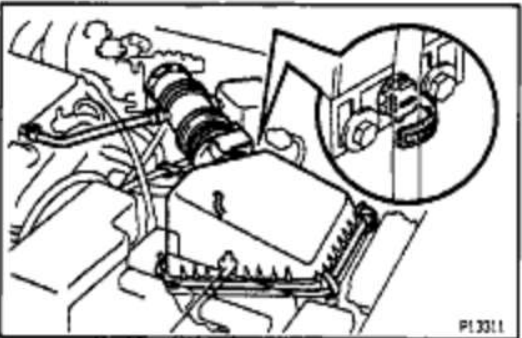

8. REINSTALL AIR CLEANER CAP, VOLUME AIR FLOW METER AND AIR CLEANER HOSE

(a) Connect the air cleaner hose, and install the air cleaner cap and volume air flow meter with the 4 clips.

(b) Tighten the air cleaner hose clamp bolt.

(c) Connect the PCV hose.

(d) Connect the accelerator cable clamp.

(e) Connect the volume air flow meter connector and wire clamp.

9. FILL WITH ENGINE COOLANT

Capacity:

8.7 liters (9.2 US qts, 7.7 Imp. qts)

10. CONNECT NEGATIVE (-) TERMINAL CABLE TO BATTERY

11. START ENGINE AND CHECK FOR LEAKS

12. RECHECK ENGINE COOLANT LEVEL

RADIATOR

MML-01

RADIATOR CLEANING

Using water or a steam cleaner, remove any mud and dirt from the radiator core.

NOTICE: If using a high pressure type cleaner, be careful not to deform the fins of the radiator core. If the cleaner nozzle pressure is 2,942 – 3,432 kPa (30 – 35 kgf/cm², 427 – 498 psi), keep a distance of at least 40 cm (15.75 in.) between the radiator core and cleaner nozzle.

MML-01

RADIATOR INSPECTION

1. REMOVE RADIATOR CAP FROM WATER OUTLET

CAUTION: To avoid the danger of being burned, do not remove the radiator cap while the engine and radiator are still hot, as fluid and steam can be blown out under pressure.

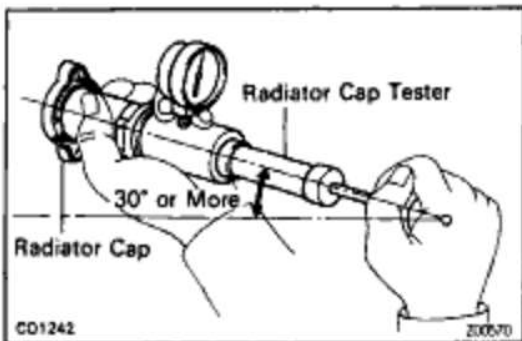

2. INSPECT RADIATOR CAP

NOTICE: When performing steps (a) and (b) below, keep the radiator pump tester at an angle of over 30° above the horizontal.

(a) Using a radiator cap tester, slowly pump the tester and check that air is coming from the relief valve.

Pump speed:

1 push/3 seconds or more

NOTICE: Push the pump at a constant speed.

If air is not coming from the relief valve, replace the radiator cap.

(b) Pump the tester several times and measure the relief valve opening pressure.

Pump speed:

1 at time

1 push/1 second or less

2nd time or more

Any speed

Standard opening pressure:

83 – 113 kPa

(0.85 – 1.15 kgf/cm², 12.1 – 16.4 psi)

Minimum opening pressure:

69 kPa (0.7 kgf/cm², 10.0 psi)

If the opening pressure is less than minimum, replace the radiator cap.

EG2-334

1MZ-FE ENGINE - COOLING SYSTEM

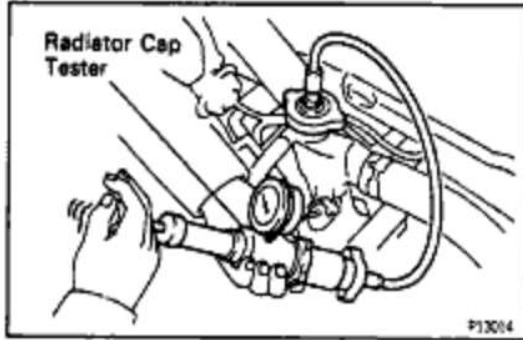
**3. INSPECT COOLING SYSTEM FOR LEAKS**

- (a) Fill the radiator and engine with coolant and attach a radiator cap tester.
- (b) Warm up the engine.
- (c) Pump it to 127 kPa (1.3 kgf/cm², 18.5 psi), and check that the pressure does not drop.

If the pressure drops, check the hoses, radiator or water pump for leaks. If no external leaks are found, check the heater core, cylinder block and cylinder head.

**4. REINSTALL RADIATOR CAP**

COMPONENTS FOR REMOVAL AND INSTALLATION

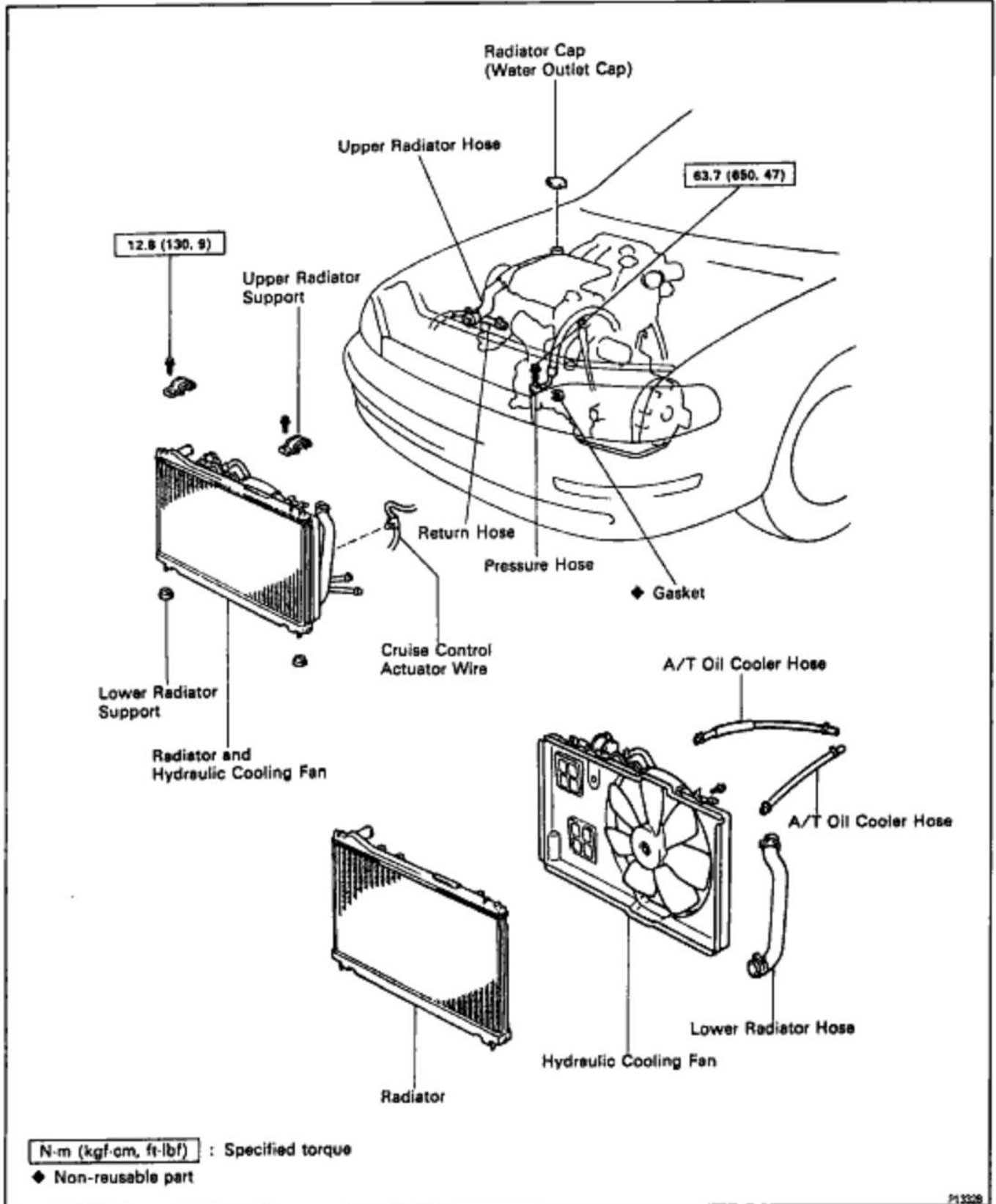

EG2-336

1MZ-FE ENGINE - COOLING SYSTEM

RM7-41

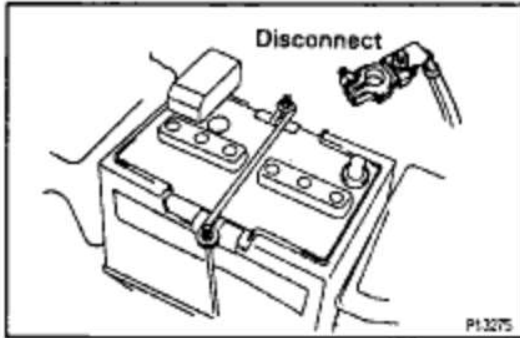

RADIATOR REMOVAL

(See Components for Removal and Installation)

1. DISCONNECT NEGATIVE (-) TERMINAL CABLE FROM BATTERY

CAUTION: Work must be started after 90 seconds from the time the ignition switch is turned to the 'LOCK' position and the negative (-) terminal cable is disconnected from the battery.

2. DRAIN ENGINE COOLANT

3. DISCONNECT PRESSURE HOSE

Remove the union bolt and gasket, and disconnect the pressure hose from the hydraulic motor.

NOTICE: Catch leaking oil in a container.

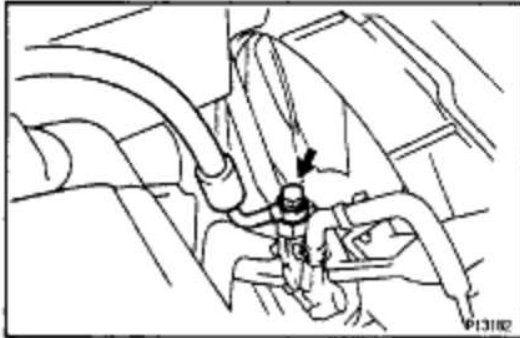

4. DISCONNECT UPPER RADIATOR HOSE

5. DISCONNECT HYDRAULIC MOTOR RETURN HOSE

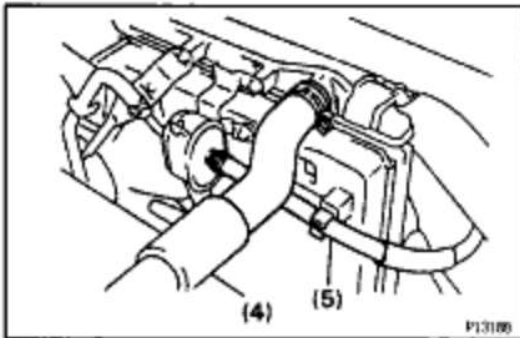

6. DISCONNECT LOWER RADIATOR HOSE FROM WATER INLET PIPE

7. DISCONNECT OIL COOLER HOSES FROM OIL COOLER PIPES

Disconnect the 2 hoses.

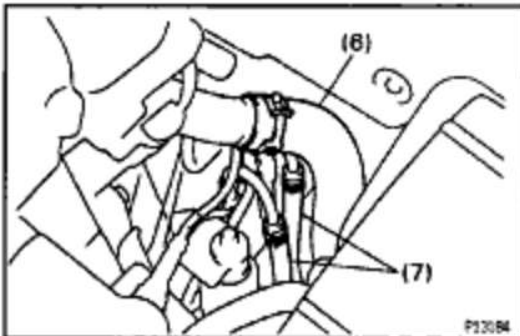

8. Canada only:

REMOVE NO.7 RELAY BLOCK

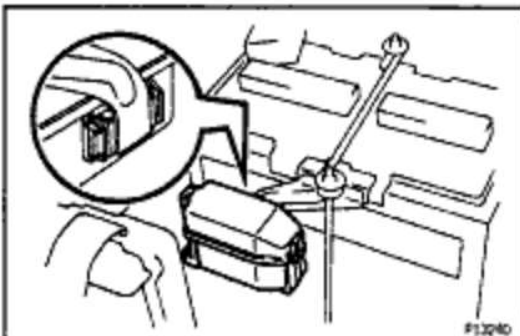



9. DISCONNECT CRUISE CONTROL ACTUATOR WIRE CLAMP

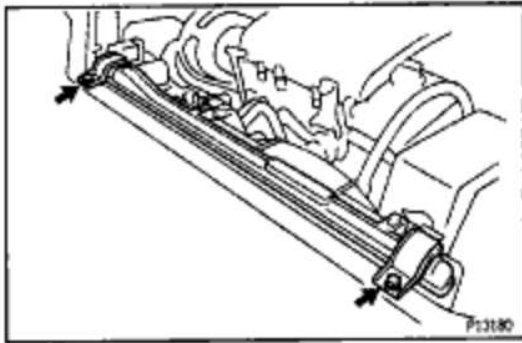

10. REMOVE RADIATOR AND HYDRAULIC COOLING FAN

- (a) Remove the 2 bolts and 2 upper supports.
- (b) Lift out the radiator.

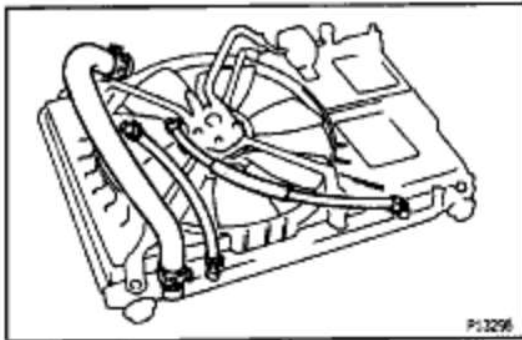

11. REMOVE A/T OIL COOLER HOSES

Remove the 2 hoses.

12. REMOVE RADIATOR LOWER HOSE

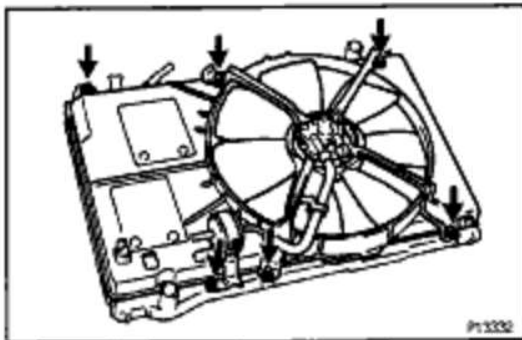

13. REMOVE HYDRAULIC COOLING FAN FROM RADIATOR

Remove the 6 bolts and cooling fan.

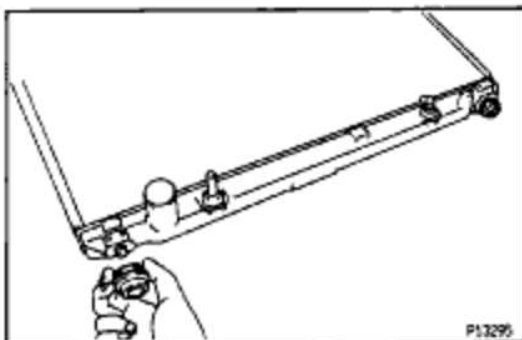

14. REMOVE LOWER RADIATOR SUPPORTS

Remove the 2 lower radiator supports.

EG2-338

1MZ-FE ENGINE - COOLING SYSTEM

COMPONENTS FOR DISASSEMBLY AND ASSEMBLY

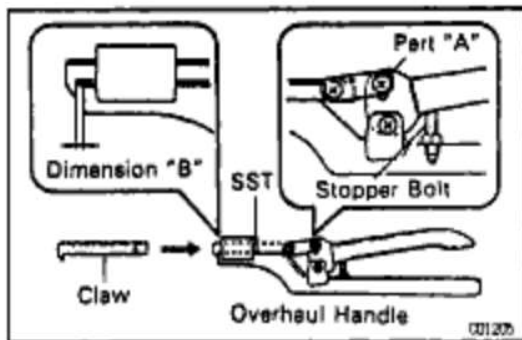
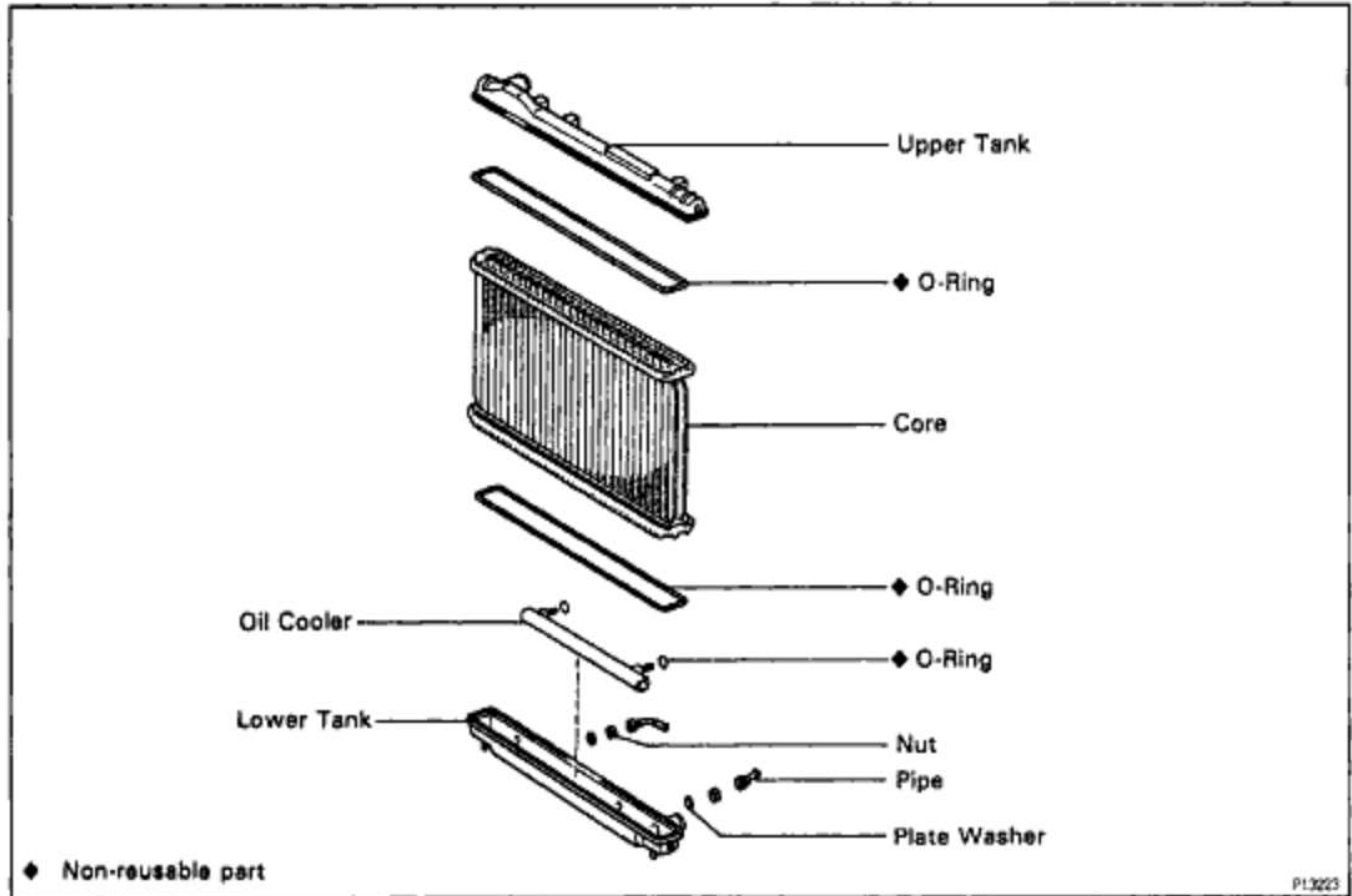

RADIATOR DISASSEMBLY

(See Components for Disassembly and Assembly)

ASSEMBLY OF SST

09230 - 01010

(a) Install the claw to the overhaul handle, inserting it in the hole in part "A" as shown in the diagram.

(b) While gripping the handle, adjust the stopper bolt so that dimension "B" shown in the diagram is 0.2–0.5 mm (0.008–0.020 in.).

NOTICE: If this adjustment is not performed, the claw may be damaged.

1MZ-FE ENGINE - COOLING SYSTEM

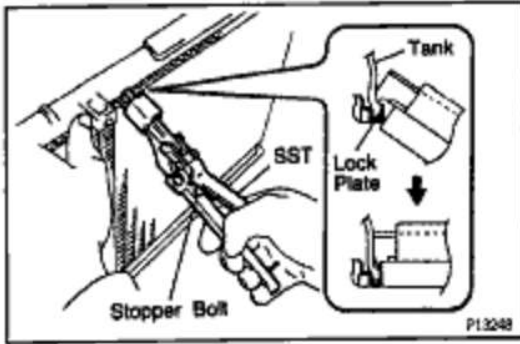
**2. UNCAULK LOCK PLATES**

Using SST to release the caulking, squeeze the handle until stopped by the stopper bolt.

SST 09230 - 01010

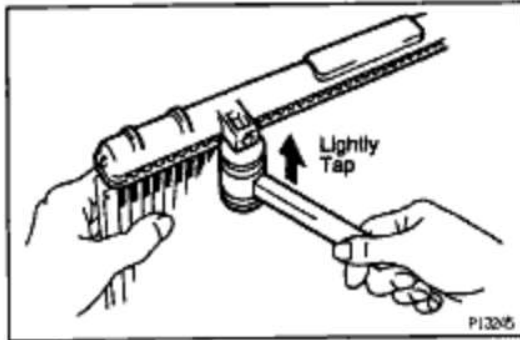
**3. REMOVE TANKS AND O-RINGS**

(a) Lightly tap the bracket of the radiator (or radiator hose inlet or outlet) with a soft-faced hammer and remove the tank.

(b) Remove the O-ring.

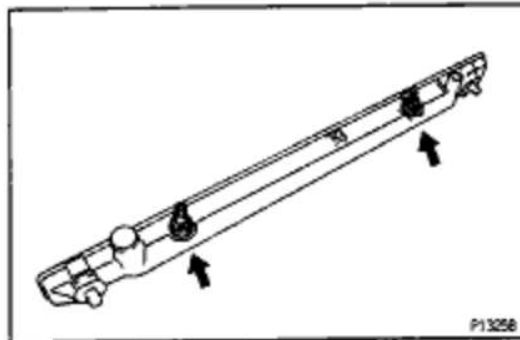
**4. REMOVE OIL COOLER FROM LOWER TANK**

(a) Remove the pipes.

HINT: Make a note of the direction to face the pipes.

(b) Remove the nuts, and plate washers.

(c) Remove the oil cooler and O-rings.

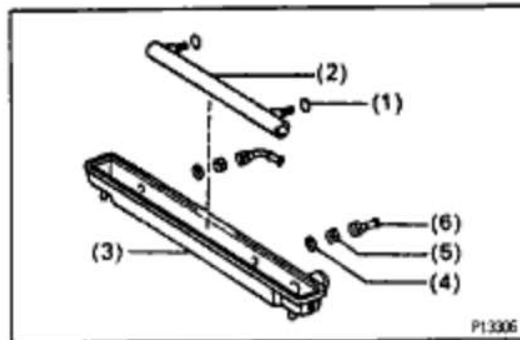
**RADIATOR ASSEMBLY**

(See Components for Disassembly and Assembly)

1. INSTALL OIL COOLER TO LOWER TANK

(a) Clean the O-ring contact surface of the lower tank and oil cooler.

(b) Install new O-rings (1) to the oil cooler (2).

(c) Install the oil cooler with the O-rings to the lower tank (3).

(d) Install the plate washers (4), and nuts (5). Torque the nuts.

Torque: 8.3 N-m (85 kgf-cm, 74 ft-lbf)

(e) Install the pipes (6).

Torque: 14.7 N-m (150 kgf-cm, 11 ft-lbf)

HINT: Face the pipes in the same direction as before disassembly.

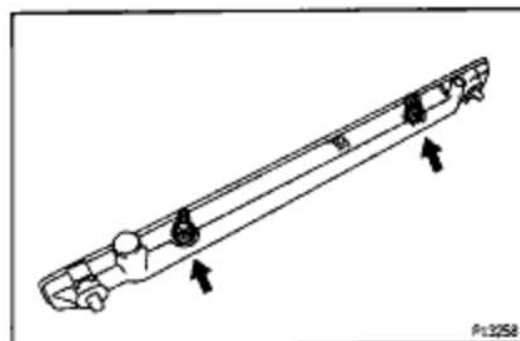

EG2-340

1MZ-FE ENGINE - COOLING SYSTEM

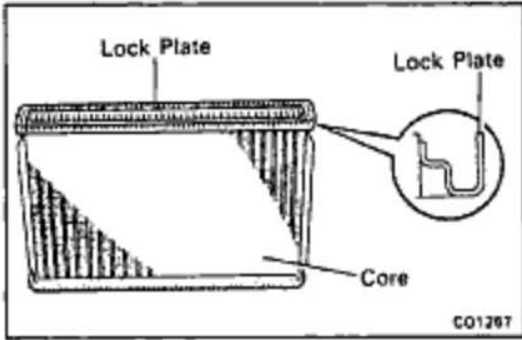

2. INSPECT LOCK PLATE

Inspect the lock plate for damage.

HINT:

- If the sides of the lock plate groove are deformed, reassembly of the tank will be impossible.
- Therefore, first correct any deformation with pliers or similar object. Water leakage will result if the bottom of the lock plate groove is damaged or dented, Therefore, repair or replace if necessary.

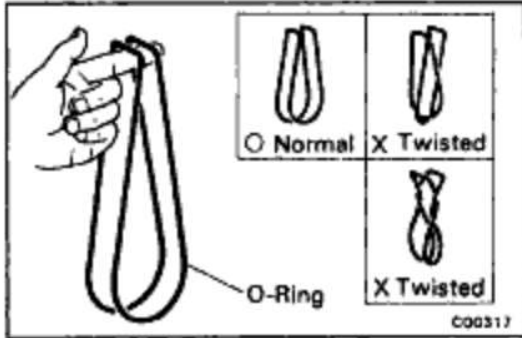

3. INSTALL NEW O-RINGS AND TANKS

(a) After checking that there are no foreign objects in the lock plate groove, install the new O-ring without twisting it.

HINT: When cleaning the lock plate groove, lightly rub it with sand paper without scratching it.

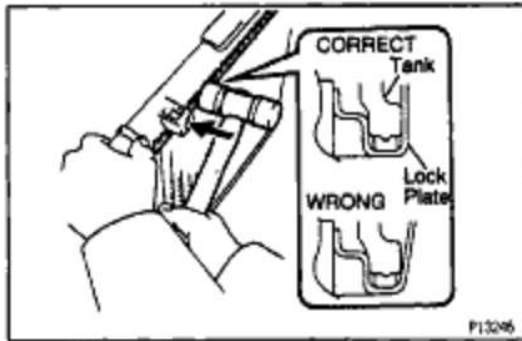

(b) Install the tank without damaging the O-ring.

(c) Tap the lock plate with a soft-faced hammer so that there is no gap between it and the tank.

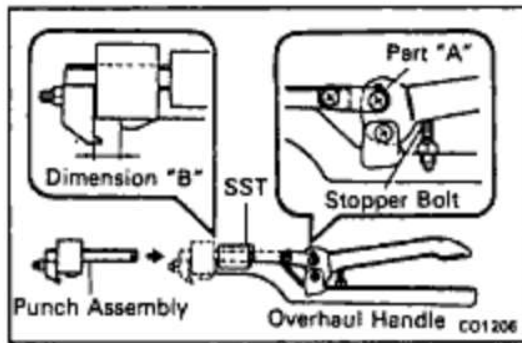

4. ASSEMBLY OF SST

SST 09230 - 01010

(a) Install the punch assembly to the overhaul handle, inserting it in the hole in part "A" as shown in the illustration.

(b) While gripping the handle, adjust the stopper bolt so that dimension "B" shown in the diagram is 7.7 mm (0.30 in.).

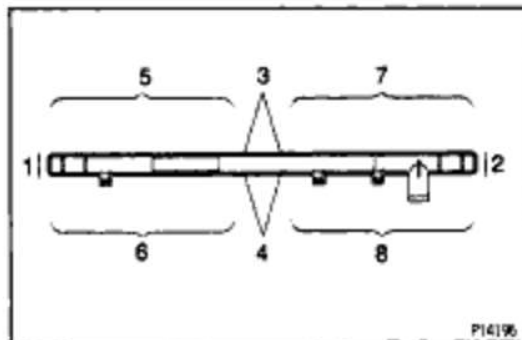

5. CAULK LOCK PLATE

(a) Lightly press SST against the lock plate in the order shown in the illustration. After repeating this a few times, fully caulk the lock plate by squeezing the handle until stopped by the stopper plate.

SST 09230 - 01010

1MZ-FE ENGINE - COOLING SYSTEM

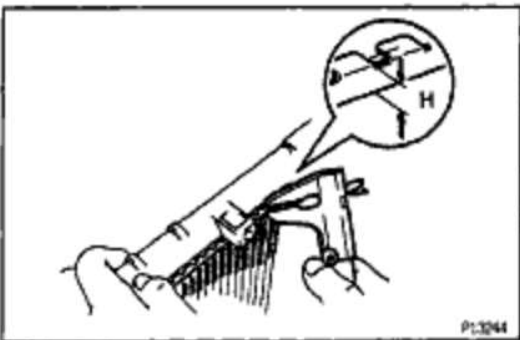
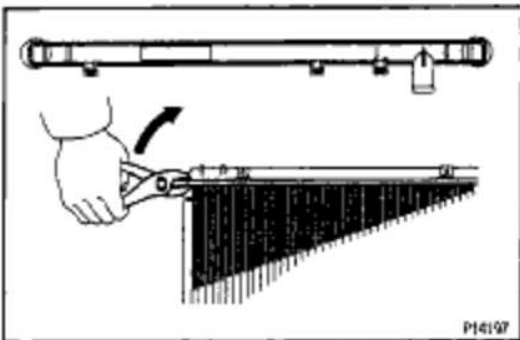
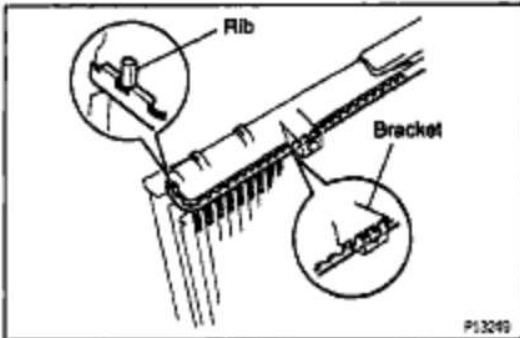
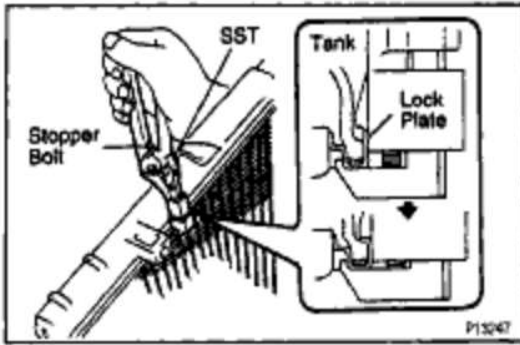

HINT:

- Do not stake the areas protruding around the pipes, brackets or tank ribs.

- The points shown in the illustration and oil cooler near here cannot be staked with the SST. Use a plier or similar object and be careful not to damage the core plates.

(b) Check the lock plate height (H) after completing the caulking.

Plate height:

7.75 – 8.25 mm (0.305 – 0.325 in.)

If not within the specified height, adjust the stopper bolt of the handle again and perform the caulking again.

6. PAINT LOCK PLATES

EG2-342

1MZ-FE ENGINE - COOLING SYSTEM

R0001-01

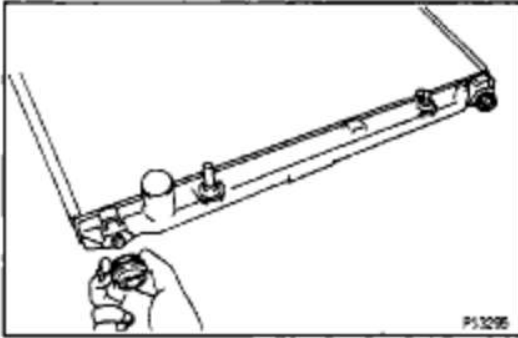
**RADIATOR INSTALLATION**

(See Components for Removal and Installation)

1. INSTALL RADIATOR SUPPORTS

Install the 2 supports.

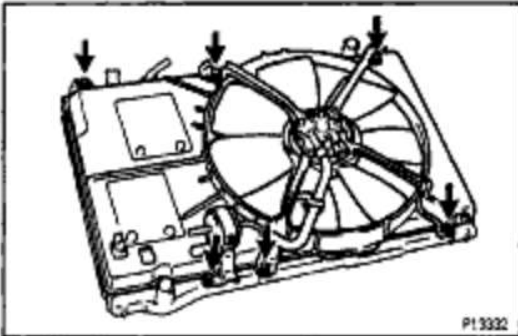
**2. INSTALL HYDRAULIC COOLING FAN TO RADIATOR**

Install the cooling fan with the 6 bolts.

Torque: 4.9 N-m (50 kgf-cm, 43 in.-lbf)

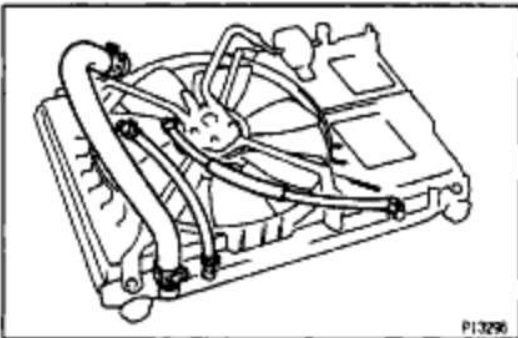
**3. INSTALL RADIATOR LOWER HOSE****4. INSTALL A/T OIL COOLER HOSES**

Install the 2 hoses.

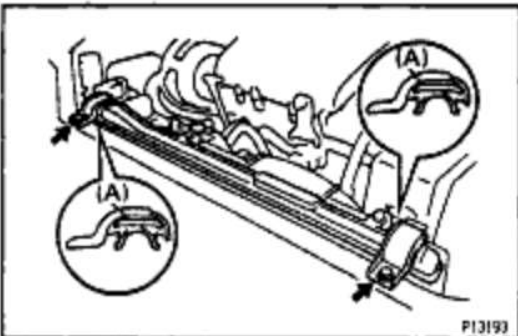
**6. INSTALL RADIATOR AND HYDRAULIC COOLING FAN**

Place the radiator in position, and install the 2 upper supports with the 2 bolts.

Torque: 12.8 N-m (130 kgf-cm, 9 ft-lbf)

HINT: After installation, check that the rubber cushion (A) of the support is not depressed.

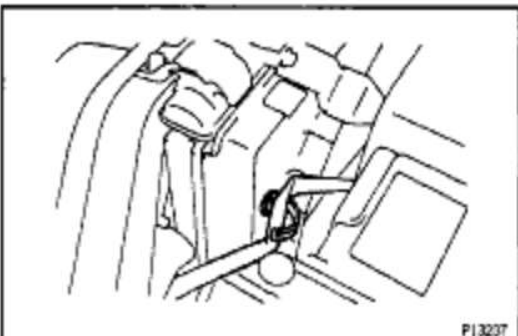
**6. CONNECT CRUISE CONTROL ACTUATOR WIRE CLAMP**

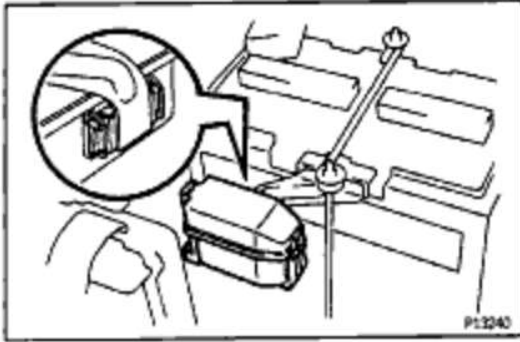

**7. Canada only:
INSTALL NO.7 RELAY BLOCK**

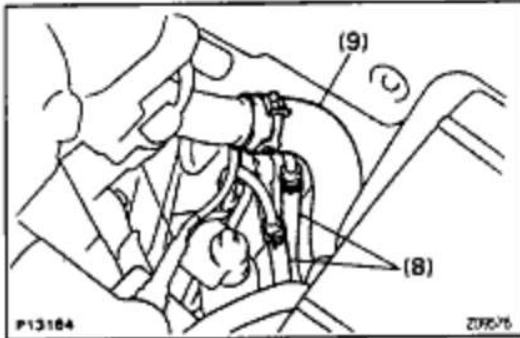

**8. CONNECT OIL COOLER HOSES
9. CONNECT LOWER RADIATOR HOSE**

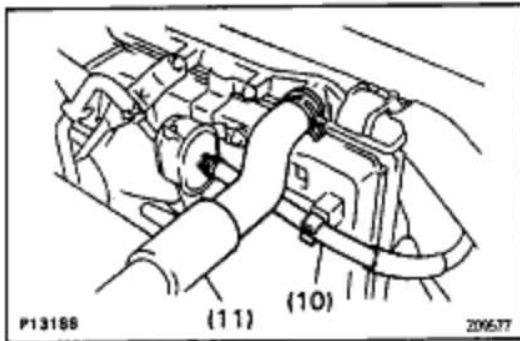

**10. CONNECT HYDRAULIC MOTOR RETURN HOSE
11. CONNECT UPPER RADIATOR HOSE**

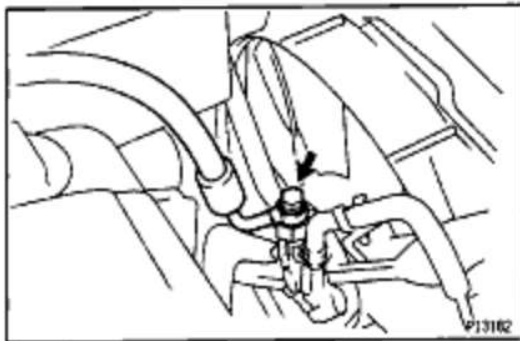

12. CONNECT PRESSURE HOSE TO HYDRAULIC MOTOR

Connect the pressure hose with a new gasket and the union bolt.

Torque: 63.7 N-m (650 kgf-cm, 47 ft-lbf)

13. FILL WITH ENGINE COOLANT

Capacity:

8.7 liters (9.2 US qts, 7.7 Imp. qts)

14. FILL COOLING FAN (PS) RESERVOIR TANK WITH FLUID

15. CONNECT NEGATIVE (-) TERMINAL CABLE TO BATTERY

16. START ENGINE AND CHECK FOR LEAKS

EG2-344**1MZ-FE ENGINE - COOLING SYSTEM**

**17. BLEED ELECTRONICALLY CONTROLLED
HYDRAULIC COOLING FAN SYSTEM****(See page [EG2-348](#))****18. CHECK AUTOMATIC TRANSMISSION FLUID
LEVEL****NOTICE: Do not overfill.****19. RECHECK ENGINE COOLANT LEVEL**

ELECTRONICALLY CONTROLLED HYDRAULIC COOLING FAN SYSTEM

Description

In this system, the cooling fan ECU controls the hydraulic pressure acting on the hydraulic motor, thus controlling the speed of the cooling fan steplessly in response to the condition of the engine and air conditioning.

System Circuit

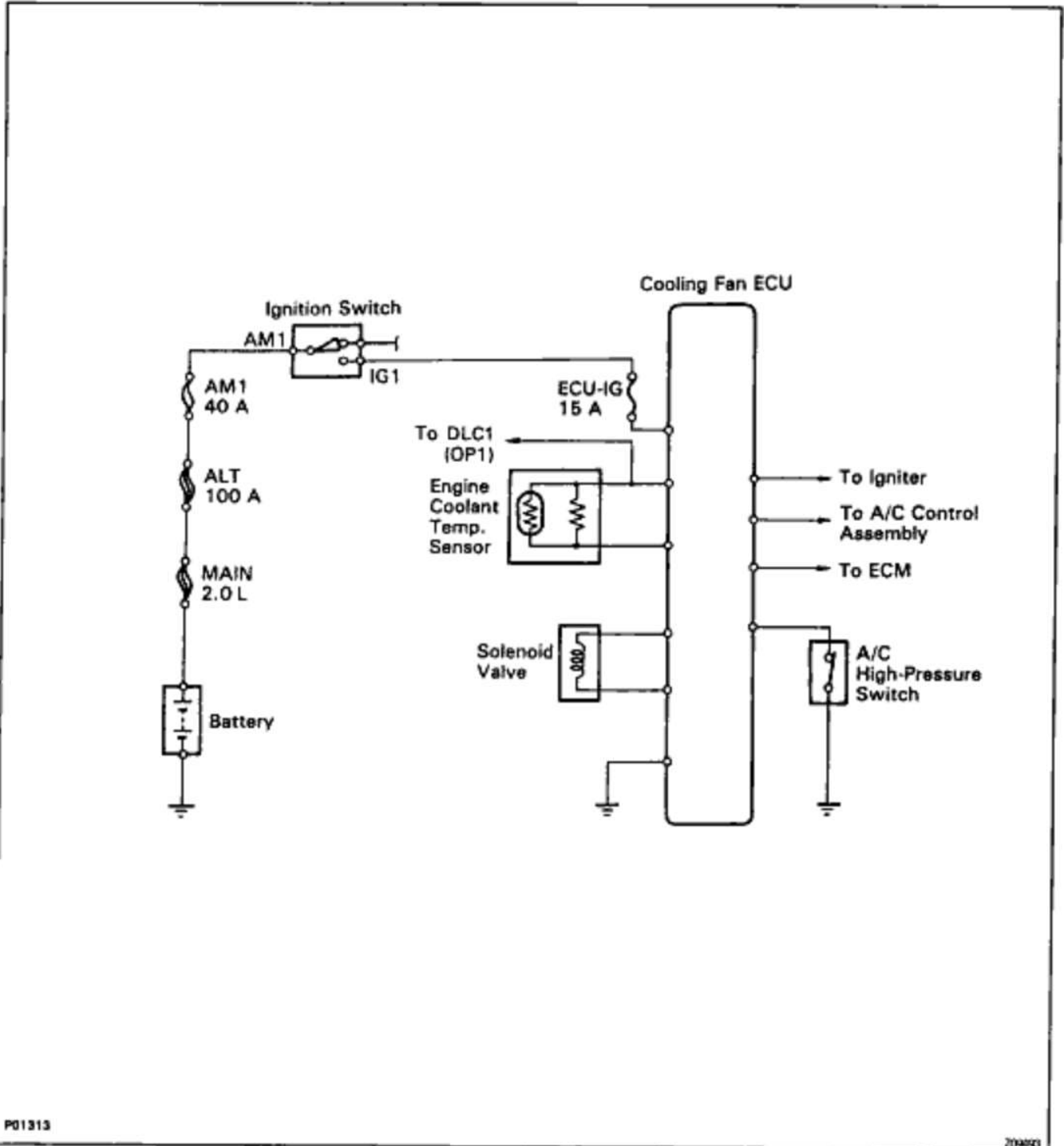

EG2-346

1MZ-FE ENGINE - COOLING SYSTEM

MMAE-34

Operation

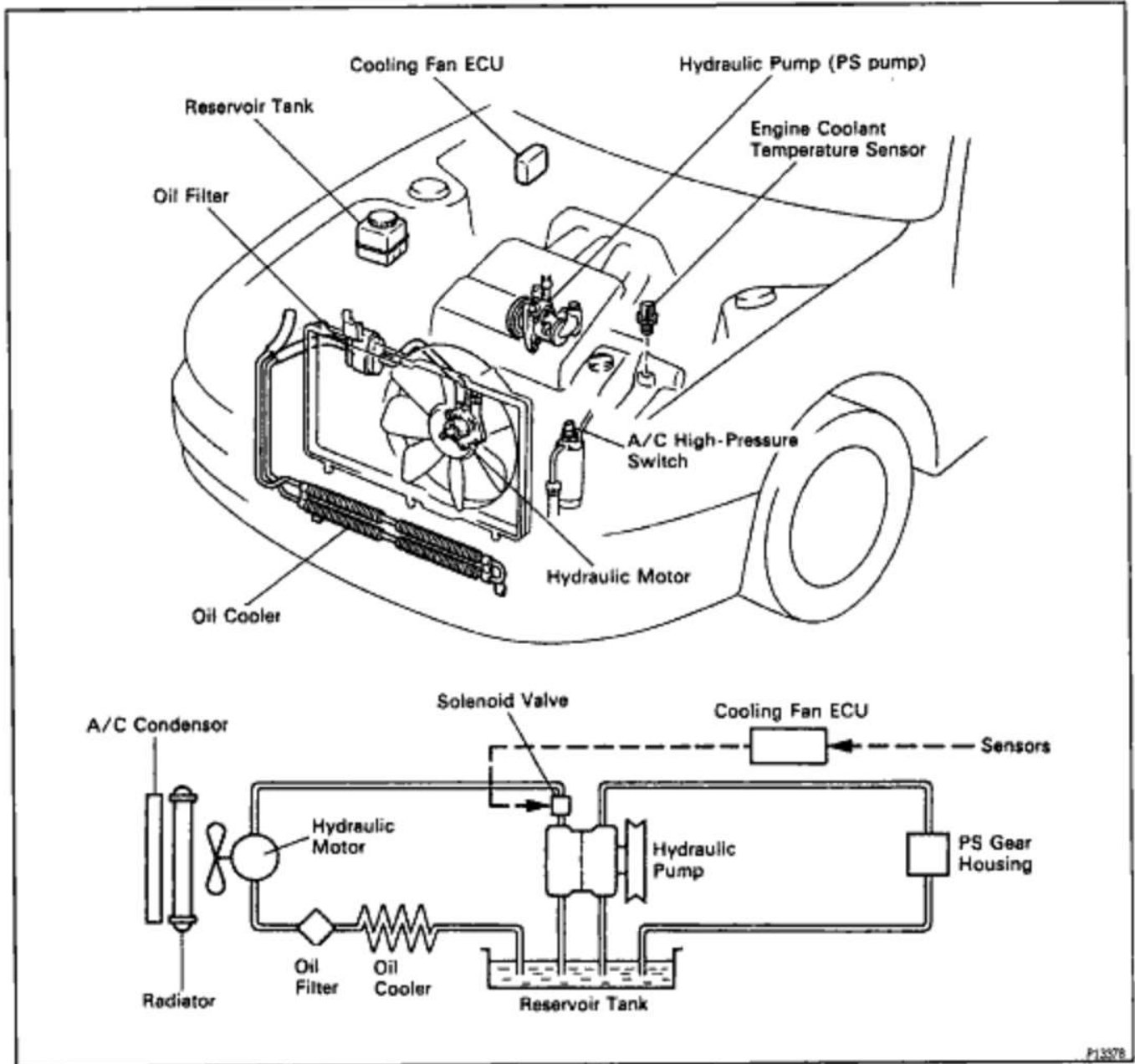

The hydraulic pump is integrated with the PS pump and is driven by a drive belt. The solenoid valve adjusts the volume of oil sent from the hydraulic pump to the hydraulic motor which drive; the fan directly, thereby controlling the fan speed.

Oil which has passed through the hydraulic motor is cooled by the oil cooler before returning to the PS pump reservoir tank.

The solenoid valve is controlled by the cooling fan ECU in accordance with the engine rpm, engine coolant temperature and A/C signals.

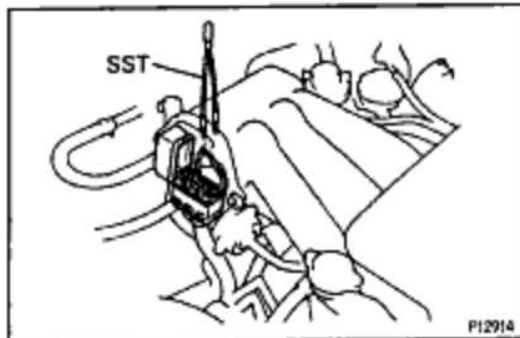
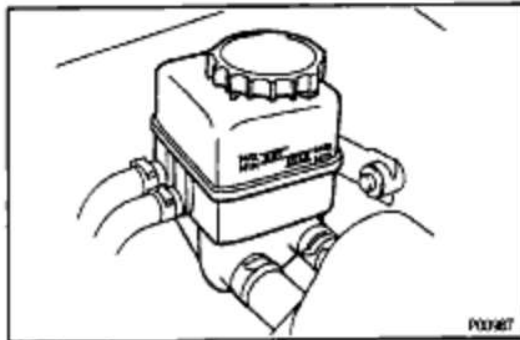
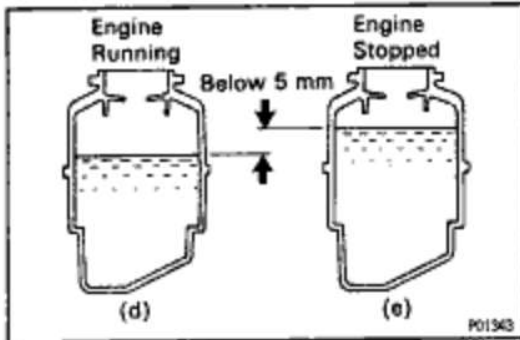
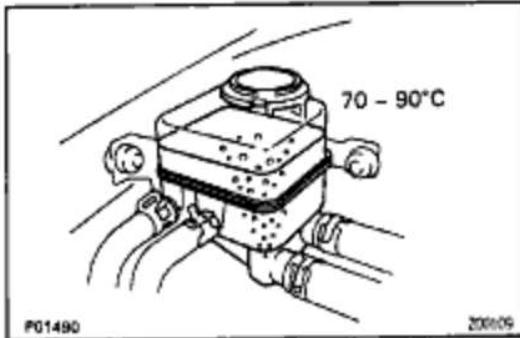
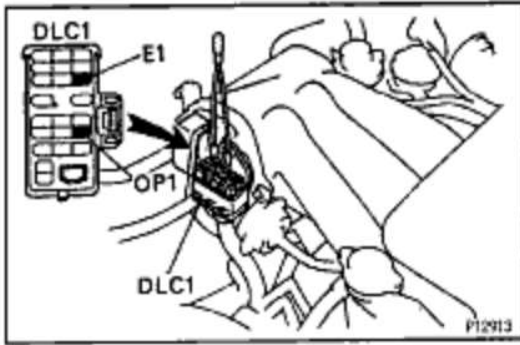

On-Vehicle Inspection FLUID LEVEL INSPECTION

1. KEEP VEHICLE LEVEL
2. INSPECT FLUID LEVEL

(a) Using SST, connect terminals OP1 and E1 of the data link connector 1.

SST 09843-18020

HINT: When terminals OP1 and E1 are connected, the circuit of the ECT sensor is grounded, fixing the cooling fan speed at approx. 1,100 rpm. (Fail-safe operation occurs.)

(b) Keep the engine speed at 2,000 rpm until the fluid temperature reaches the specified temperature.

Fluid temperature:

70 - 90°C (158 - 195°F)

(c) Check that there is no foaming and emulsification of the fluid in the reservoir tank.

(d) Measure the fluid level with the engine running.

(e) Stop the engine, and measure the fluid level.

(f) Subtract level (d) from (e).

Maximum level difference:

5 mm (0.20 in.)

(g) Check the fluid level.

If low, add fluid.

Fluid:

ATF DEXRON © II

HINT: Check that fluid level is within the "HOT" level on reservoir tank. If the fluid is cold, check that it is within the "COLD" level on the reservoir tank.

(h) Remove the SST from the data link connector 1.

SST 09843-18020

EG2-348

1MZ-FE ENGINE - COOLING SYSTEM

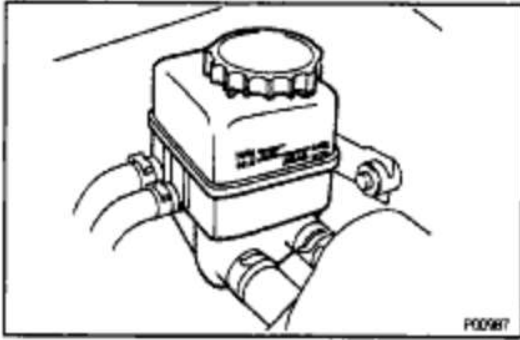

HYDRAULIC COOLING FAN SYSTEM BLEEDING

1. CHECK FLUID LEVEL IN RESERVOIR TANK

If low, add fluid.

Fluid:

ATF DEXRON®II

HINT: Check that fluid level is within the "HOT" level on reservoir tank. If the fluid is cold, check that it is within the "COLD" level on the reservoir tank.

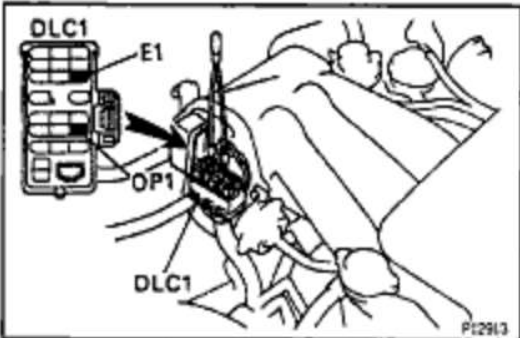

2. BLEED COOLING SYSTEM

(a) Using SST, connect terminals OP1 and E1 of the data link connector 1.

SST 09843-18020

HINT: When terminals OP1 and E1 are connected, the circuit of the ECT sensor is grounded, fixing the cooling fan speed at approx. 1,100 rpm. (Fail-safe operation occurs.)

(b) Start the engine without depressing the accelerator pedal.

(c) Leave the engine running for several seconds.

(d) Check that there is no foaming and emulsification of the fluid in the reservoir tank.

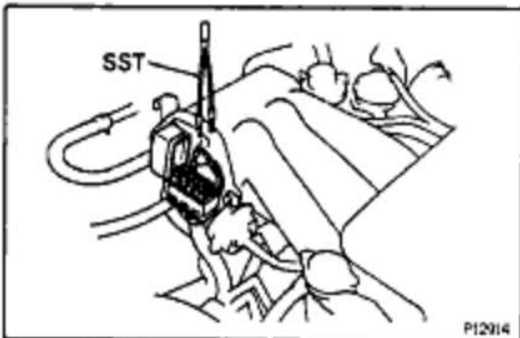
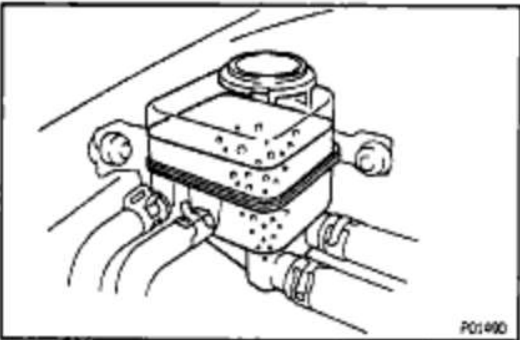

(e) Remove the SST from the data link connector 1.

SST 09843-18020

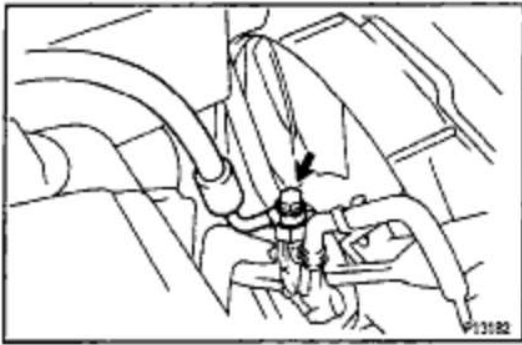

OIL PRESSURE INSPECTION

1. DISCONNECT PRESSURE HOSE FROM HYDRAULIC MOTOR, AND INSTALL OIL PRESSURE GAUGE

(a) Remove the union bolt and gasket, and disconnect the pressure hose from the hydraulic motor.

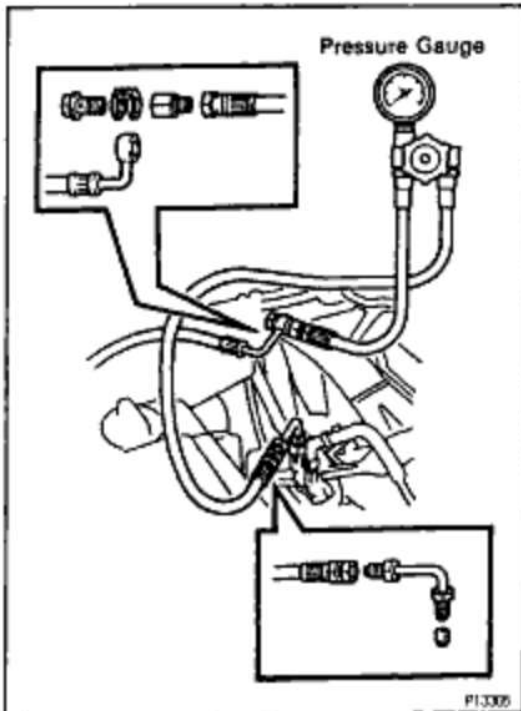

(b) Connect the gauge side of a pressure gauge to pressure hose, and the valve side to the hydraulic motor.

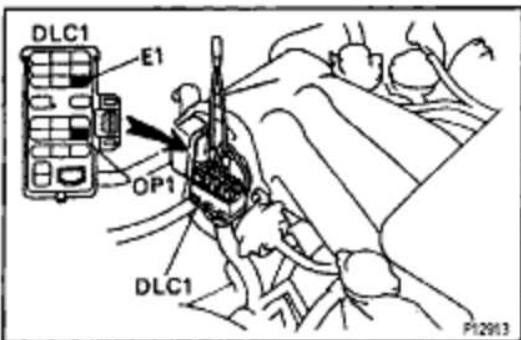

2. INSPECT OIL PRESSURE

HINT: Before inspecting the oil pressure, first check that the A/C is off.

(a) Using SST, connect terminals OP1 and E1 of the data link connector 1.

SST 09843-18020

HINT: When terminals OP1 and E1 are connected, the circuit of the ECT sensor is grounded, fixing the cooling fan speed at approx. 1,100 rpm. (Fail-safe operation occurs.)

(b) Bleed the hydraulic cooling system.

(See page [EG2-348](#))

(c) Keep the engine speed at 2,000 rpm until the fluid temperature reaches the specified temperature.

Fluid temperature:

70 - 90° C (158 - 195° F)

(d) Check the fluid level is correct.

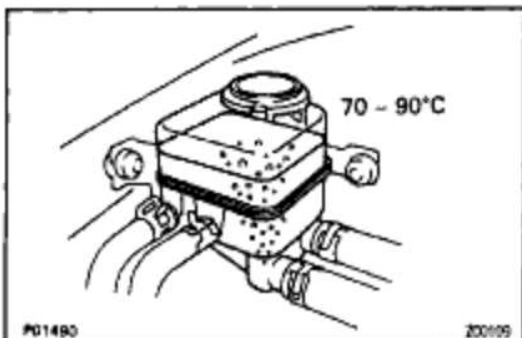

EG2-350

1MZ-FE ENGINE - FE ENGINE - COOLING SYSTEM

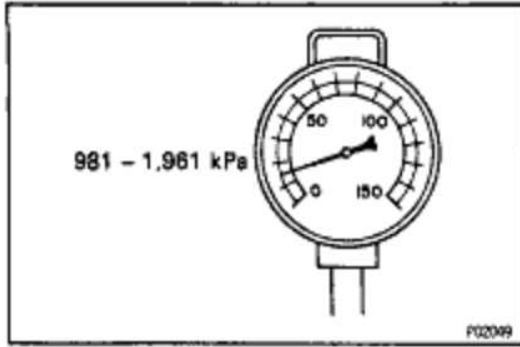

(e) Measure the oil pressure at idling.

Oil pressure:

981 - 1,961 kPa

(10 - 20 kgf/cm², 142 - 284 psi)

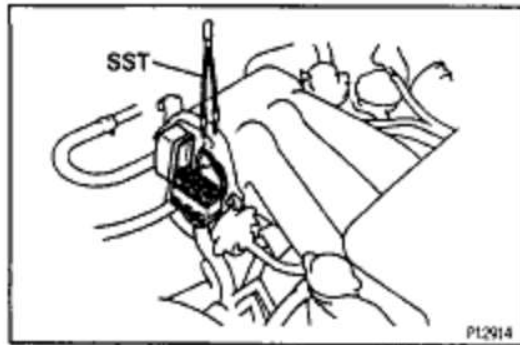

(f) Remove the SST from the data link connector 1.

SST 09843-18020

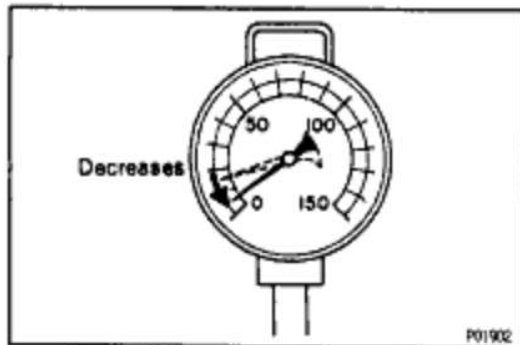

(g) Check that the oil pressure decreases.

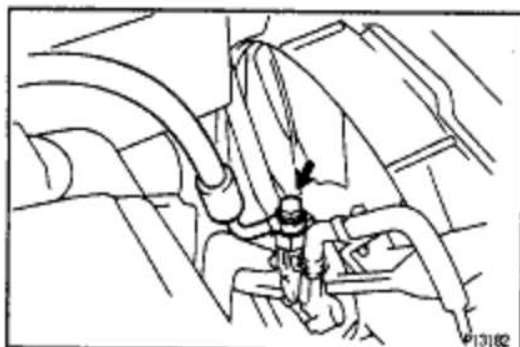

3. REMOVE OIL PRESSURE GAUGE, AND RECONNECT PRESSURE HOSE TO HYDRAULIC MOTOR

(a) Remove the pressure gauge.

(b) Connect the pressure hose to the hydraulic motor with a new gasket and the union bolt.

Torque: 63.7 N-m (650 kgf-cm, 47 ft-lbf)

Hydraulic Pump (PS pump)

(See SR section)

38/54

Hydraulic Motor COMPONENTS FOR REMOVAL AND INSTALLATION

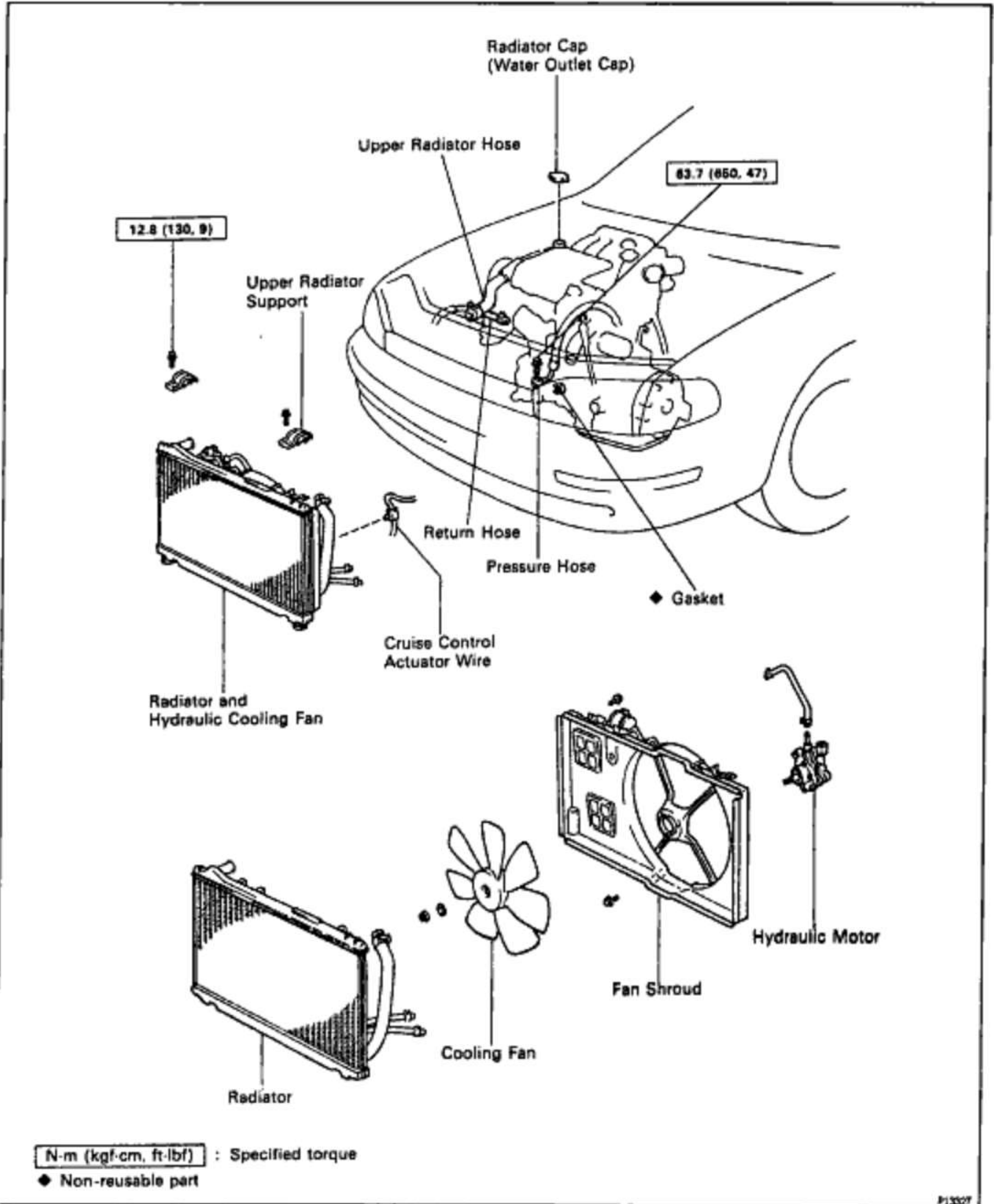

EG2-352

1MZ-FE ENGINE - COOLING SYSTEM

88881-01

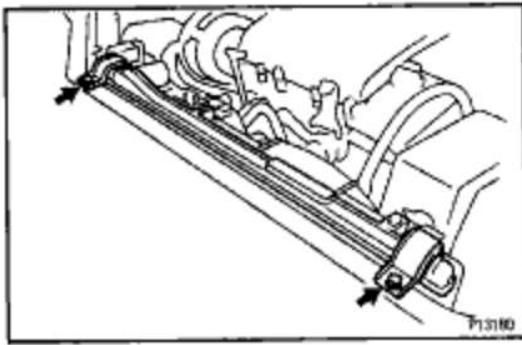
**HYDRAULIC MOTOR REMOVAL**

(See Components for Removal and Installation)

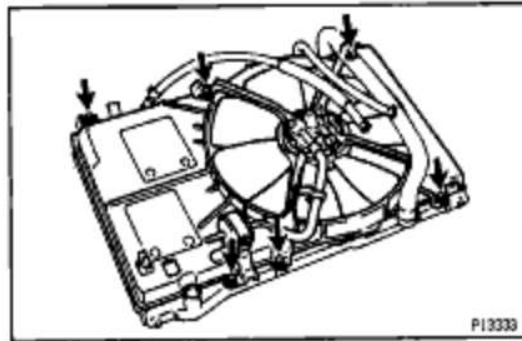
1. REMOVE RADIATOR(See page [EG2-336](#))**2. REMOVE HYDRAULIC COOLING FAN**

Remove the 6 bolts and hydraulic cooling fan.

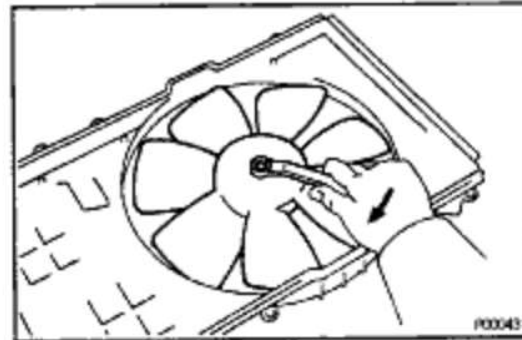
**3. REMOVE COOLING FAN FROM HYDRAULIC MOTOR**

Loosen the fan mounting nut clockwise, and remove the nut, plate washer and fan.

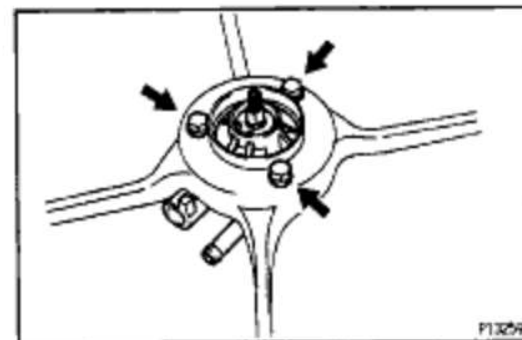
**4. REMOVE HYDRAULIC MOTOR FROM FAN SHROUD**

Remove the 3 bolts and hydraulic motor.

COMPONENTS FOR DISASSEMBLY AND ASSEMBLY

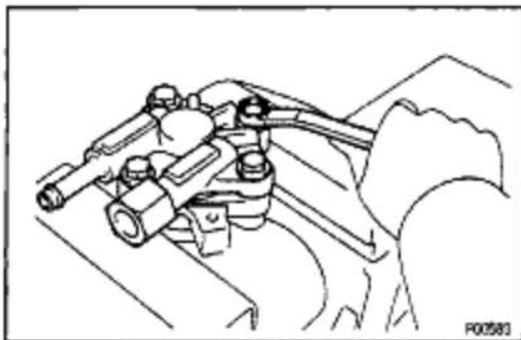
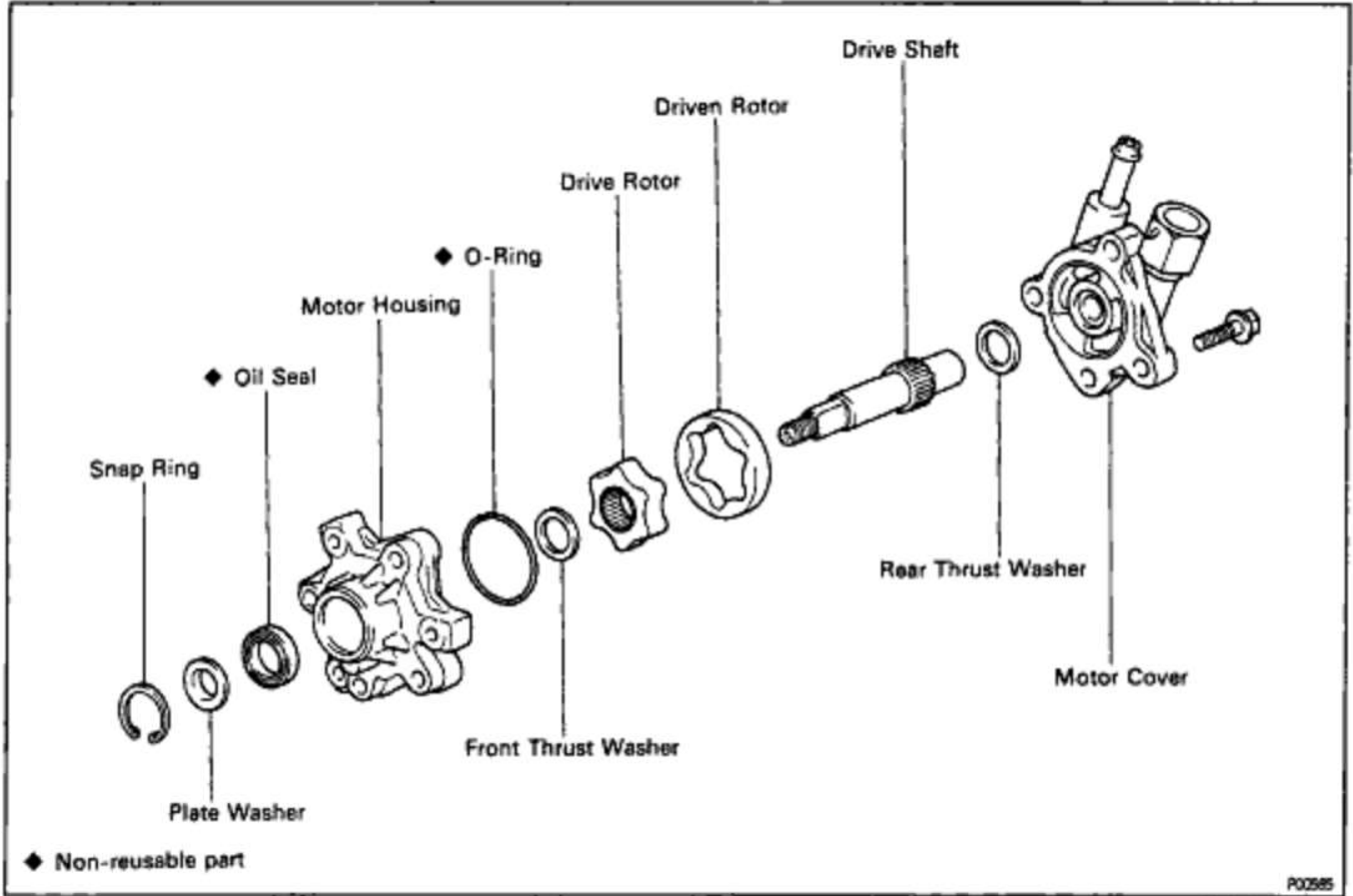

HYDRAULIC MOTOR DISASSEMBLY ^{SMAP-10} (See Components for Disassembly and Assembly)

1. MOUNT MOTOR HOUSING

Carefully mount the motor housing in a vise.

NOTICE: Be careful not to damage the motor housing.

2. REMOVE MOTOR COVER

(a) Remove the 4 bolts and motor cover.

(b) Remove the O-ring from the motor housing.

3. REMOVE REAR THRUST WASHER

4. REMOVE DRIVE SHAFT

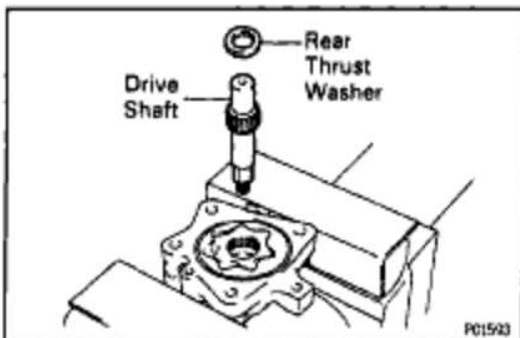

EG2-354

1MZ-FE ENGINE - COOLING SYSTEM

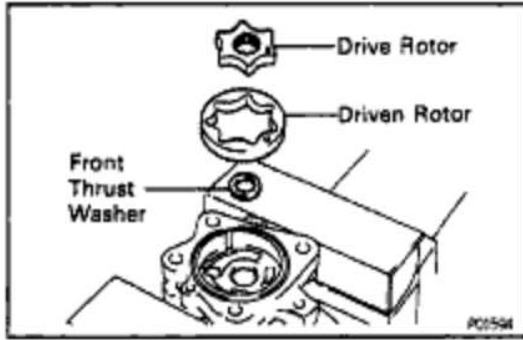

- 5. REMOVE DRIVE AND DRIVEN ROTORS
- 6. REMOVE FRONT THRUST WASHER

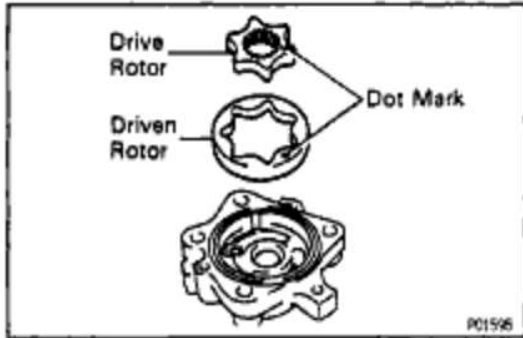

HYDRAULIC MOTOR INSPECTION

1. INSPECT DRIVE AND DRIVEN ROTORS

(a) Install the drive and driven rotors to the motor housing with the dot mark facing upward.

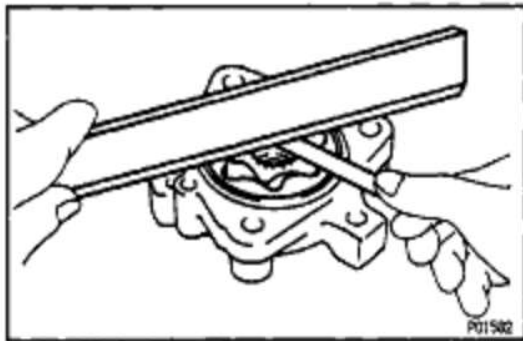

(b) Using a feeler gauge and precision straight edge, measure the side clearance between the rotor and precision straight edge.

Standard side clearance:

0.01 – 0.04 mm (0.0004 – 0.0016 in.)

Maximum side clearance:

0.05 mm (0.0020 in.)

If the clearance is greater than maximum, replace the rotors as a set. If necessary, replace the motor assembly.

HINT: When replacing the rotors, select a new rotor set according to the imprinted mark on the motor housing.

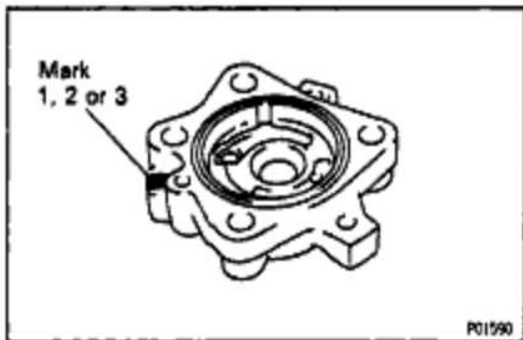

Imprinted mark on housing	Rotor set
1	16906-50010
2	16906-50020
3	16906-50030

2. INSPECT CLEARANCE OF DRIVE SHAFT

(a) Using a caliper gauge, measure the shaft hole inside diameter of the housing and cover.

Shaft hole inside diameter:

14.000 – 14.011 mm (0.5512 – 0.5516 in.)

(b) Using a micrometer, measure the drive shaft diameter.

Shaft diameter:

13.973 – 13.984 mm (0.5501 – 0.5506 in.)

(c) Subtract the drive shaft diameter measurement from the shaft hole diameter measurement.

Standard clearance:

0.016 – 0.038 mm (0.0006 – 0.0015 in.)

Maximum clearance:

0.04 mm (0.0016 in.)

If the clearance is greater than maximum, replace the shaft. If necessary, replace the motor assembly.

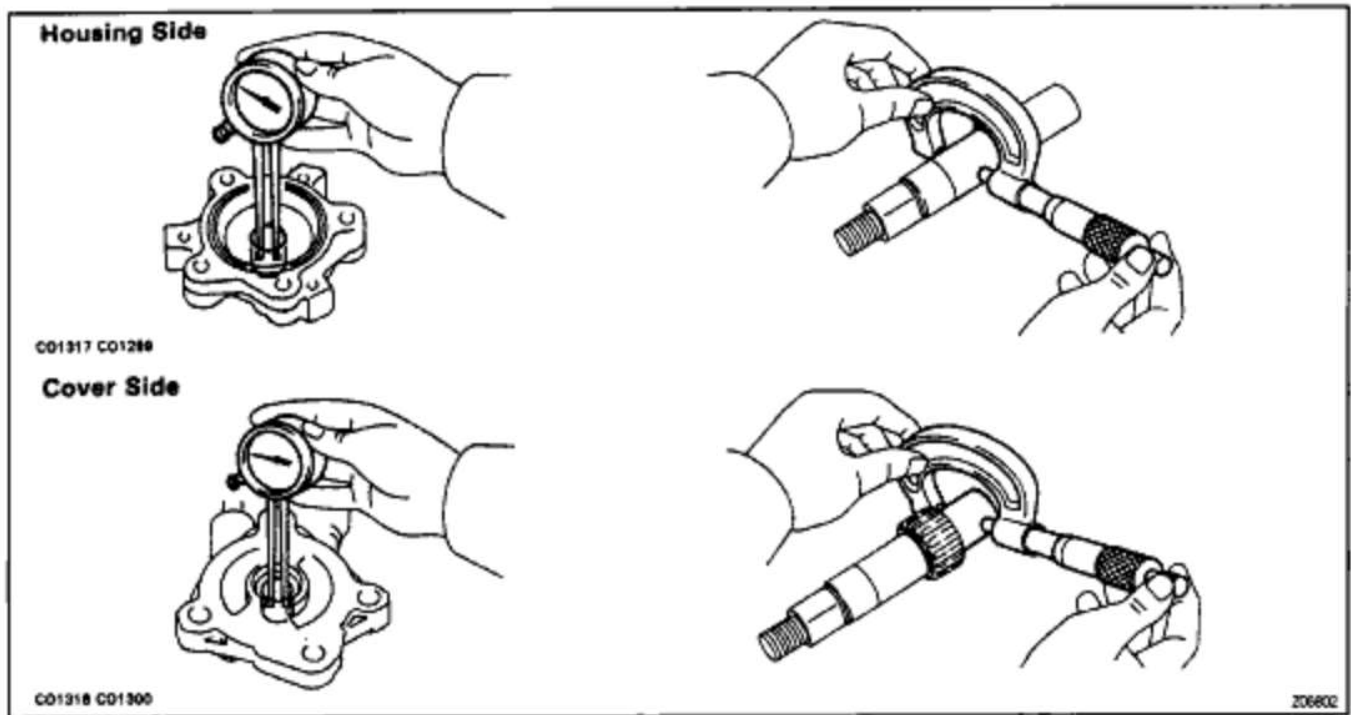

EG2-356

1MZ-FE ENGINE - FE ENGINE - COOLING SYSTEM

SEAL-08

OIL SEAL REPLACEMENT**1. REMOVE OIL SEAL**

(a) Using snap ring pliers, remove the snap ring and plate washer.

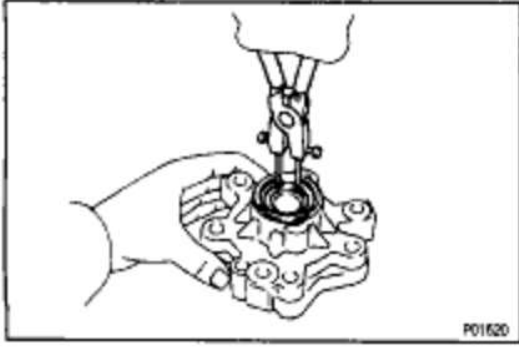

(b) Using a screwdriver, pry out the oil seal.

NOTICE: Be careful not to damage the housing.

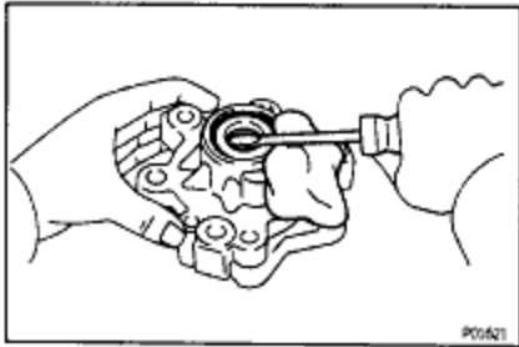
**2. INSTALL OIL SEAL**

(a) Using SST and a hammer, tap in a new oil seal to a depth of 4.5 – 5.5 mm (0.177 – 0.217 in.) from the housing edge.

SST 09620-30010 (09627-30010, 09631-00020)

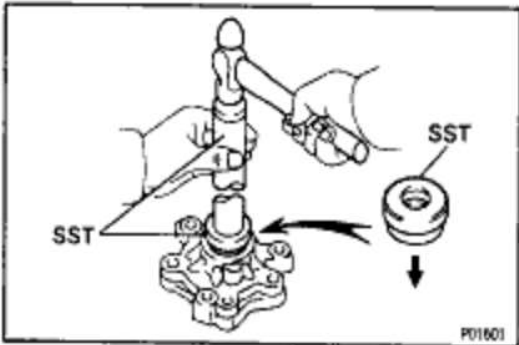

(b) Using snap ring pliers, install the plate washer and snap ring.

(c) Apply fluid to the oil seal lip.

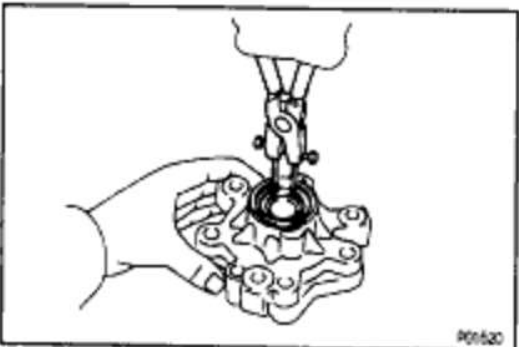

HYDRAULIC MOTOR ASSEMBLY

(See Components for Disassembly and Assembly)

HINT:

- Thoroughly clean all parts to be assembled.
- Before installing the parts, apply new fluid to all sliding and rotating surfaces.

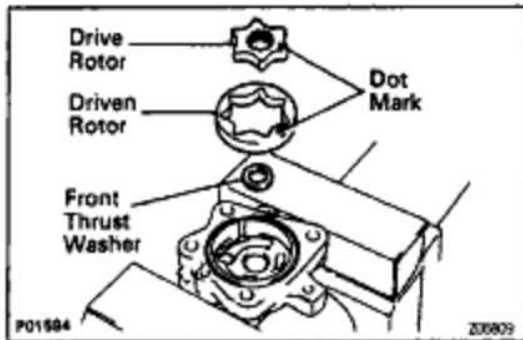

1. MOUNT MOTOR HOUSING

Slightly mount the motor housing in a vise.

NOTICE: Be careful not to damage the motor housing.

2. INSTALL FRONT THRUST WASHER

3. INSTALL DRIVEN AND DRIVE ROTORS

Install the drive and driven rotors with the dot mark facing upward.

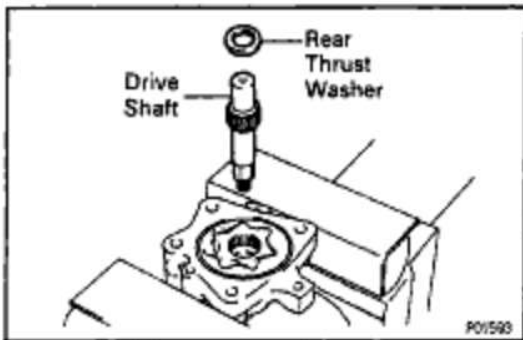

4. INSTALL DRIVE SHAFT

5. INSTALL REAR THRUST WASHER

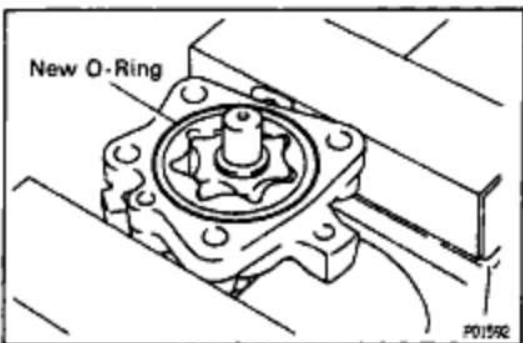

6. INSTALL MOTOR COVER

(a) Install a new O-ring to the motor housing groove.

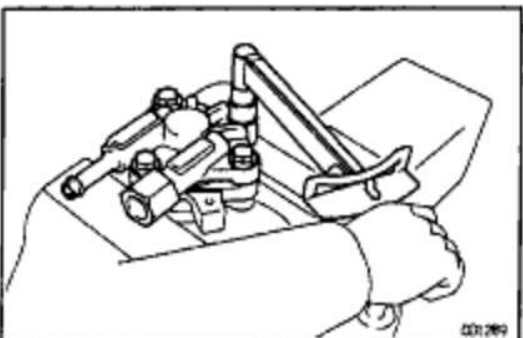

(b) Install the motor cover with the 4 bolts.

Torque: 28 N-m (290 kgf-cm, 21 ft-lbf)

EG2-358

1MZ-FE ENGINE - COOLING SYSTEM

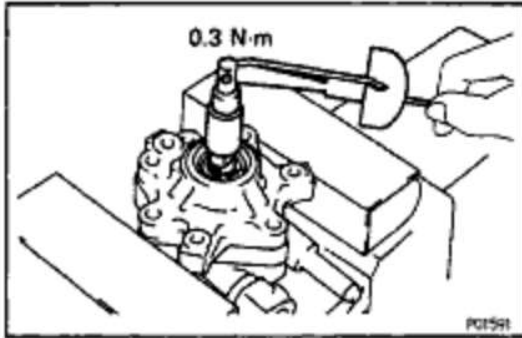
**7. INSPECT DRIVE SHAFT PRELOAD**

- (a) Check that the drive shaft rotates smoothly without abnormal noise.
 (b) Temporarily install the pulley nut, and check the rotating torque.

Rotating torque:

0.3 N-m (3.0 kgf-cm, 2.6 in.-lbf)

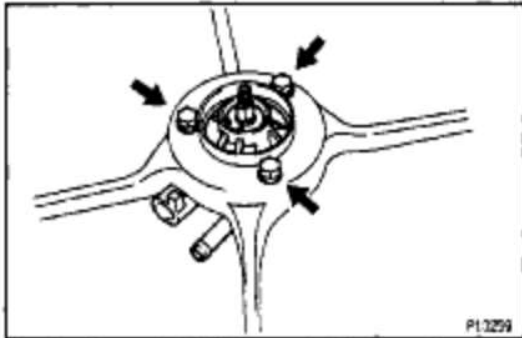
**HYDRAULIC MOTOR INSTALLATION**

(See Components for Removal and Installation)

1. INSTALL HYDRAULIC MOTOR TO FAN SHROUD

Install the hydraulic motor with the 3 bolts.

Torque: 4.9 N-m (50 kgf-cm, 43 in.-lbf)

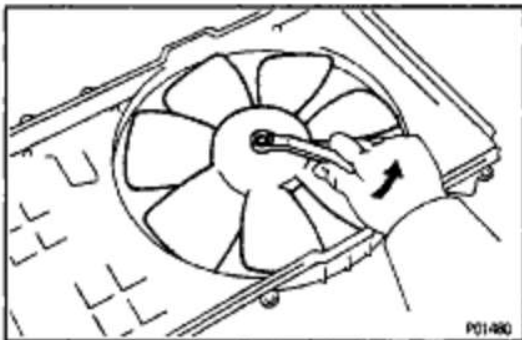
**2. INSTALL COOLING FAN TO HYDRAULIC MOTOR**

Install the fan with the plate washer and nut. Tighten the nut by turning it counterclockwise.

Torque: 15 N-m (150 kgf-cm, 11 ft.-lbf)

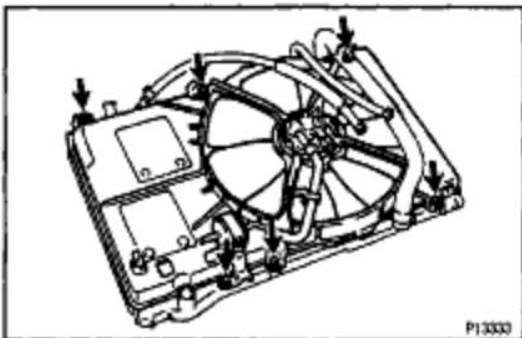
**3. INSTALL HYDRAULIC COOLING FAN**

Install the hydraulic cooling fan with the 6 bolts.

Torque: 4.9 N-m (50 kgf-cm, 43 in.-lbf)

4. INSTALL RADIATOR

(See page [EG2-342](#))

Oil Cooler COMPONENTS FOR REMOVAL AND INSTALLATION

88188-04

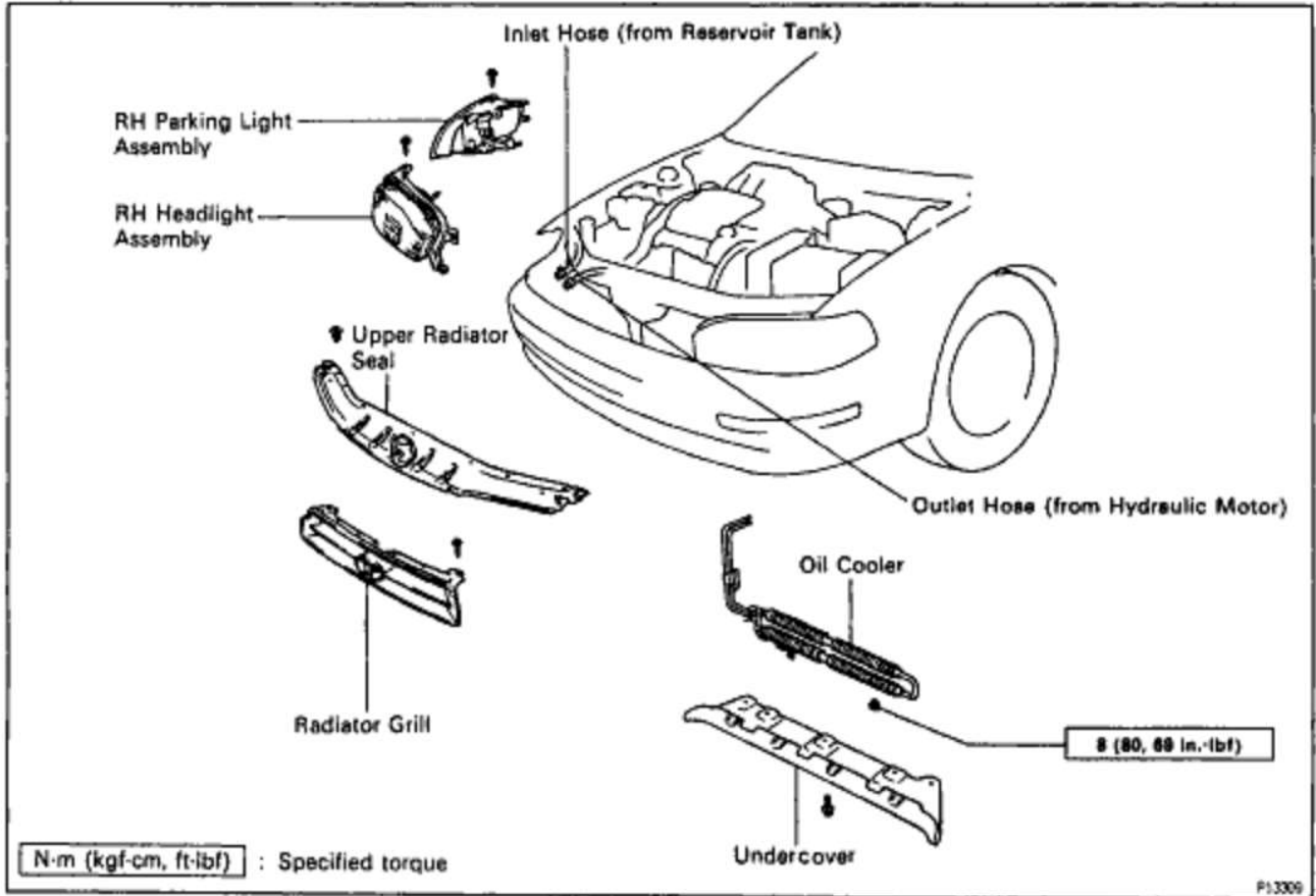

P13309

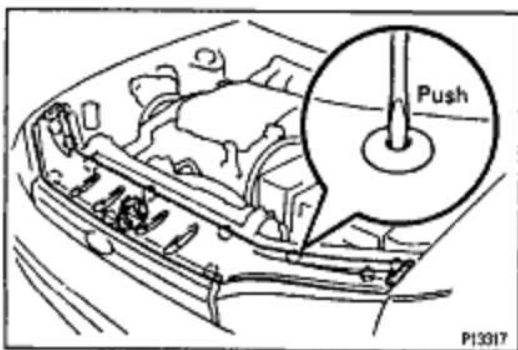

OIL COOLER REMOVAL

(See Components for Removal and Installation)

1. REMOVE UPPER RADIATOR SEAL

Remove the 12 clips and radiator seal.

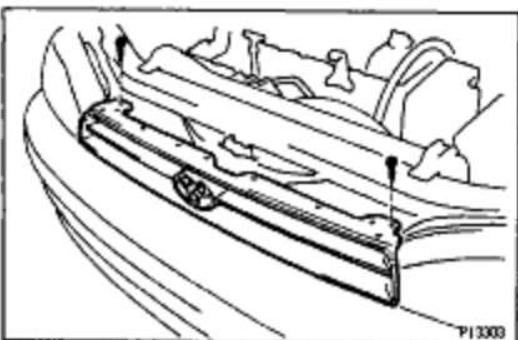

2. REMOVE RADIATOR GRILLE

Remove the 2 mounting screws and radiator grille.

EG2-360

1MZ-FE ENGINE - COOLING SYSTEM

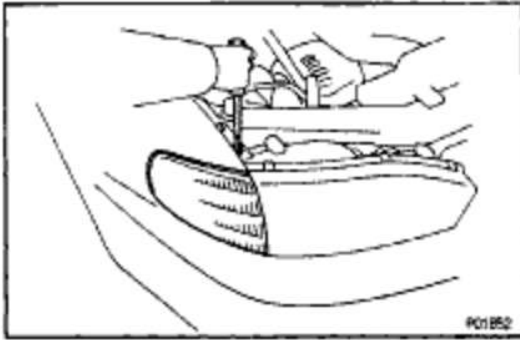
**3. REMOVE RH PARKING LIGHT ASSEMBLY**

- (a) Remove the screw.
- (b) Disconnect the connector and remove the parking light assembly.

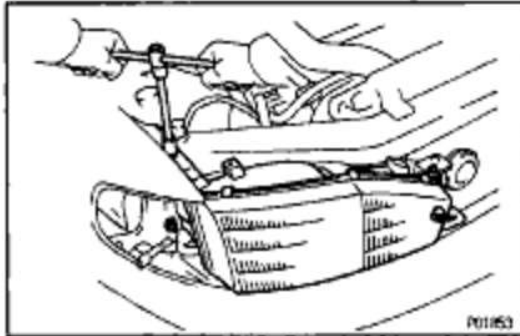
**4. REMOVE RH HEADLIGHT ASSEMBLY**

- (a) Remove the 3 bolts and nut.
- (b) Disconnect the 2 connectors and remove the headlight assembly.

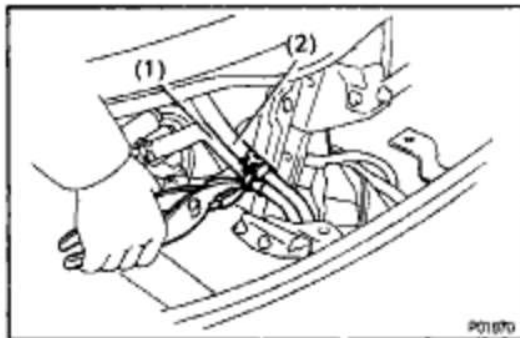
**5. DISCONNECT HOSES FROM OIL COOLER**

Disconnect the following hoses:

- (1) Outlet hose (to reservoir tank)
- (2) Inlet hose (from hydraulic motor)

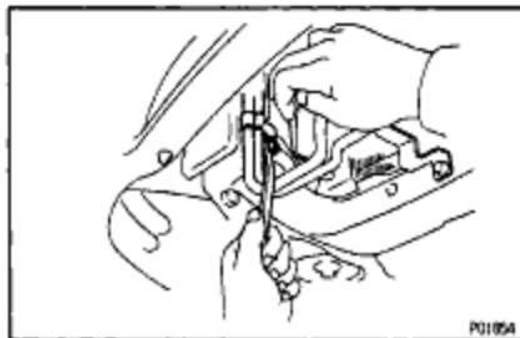
6. REMOVE UNDERCOVER**7. REMOVE OIL COOLER**

- (a) Pull aside the shroud to expose the bolt in the stay. Remove the bolt.

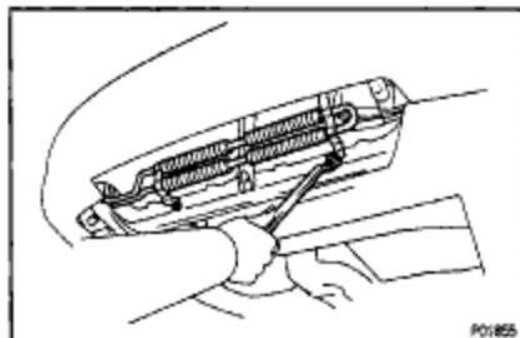

- (b) Remove the 2 nuts and remove the oil cooler.

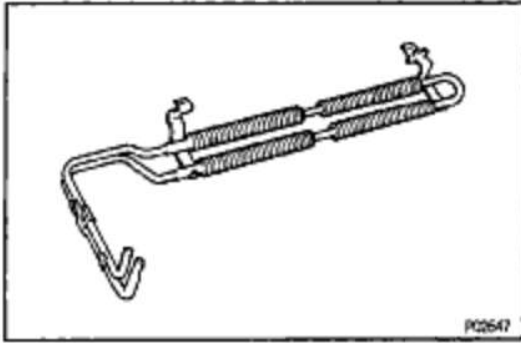

OIL COOLER INSPECTION

INSPECT OIL COOLER

Check the oil cooler for damage or clogging.
If necessary, replace the oil cooler.

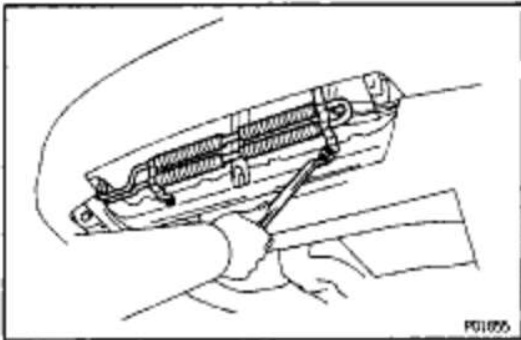

OIL COOLER INSTALLATION

(See Components for Removal and Installation)

1. INSTALL OIL COOLER

(a) Install the oil cooler with the 2 nuts.
Torque: 8 N-m (80 kgf-cm, 69 in.-lbf)

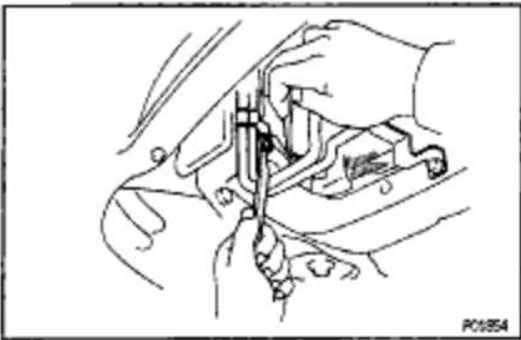

(b) Install the bolt while pulling aside the shroud.

2. INSTALL UNDERCOVER

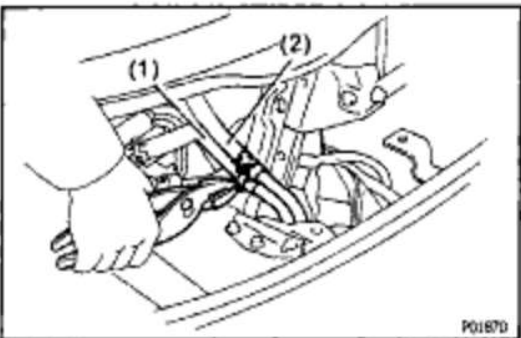

3. CONNECT HOSES TO OIL COOLER

Connect the following hoses:

- (1) Outlet hose (to reservoir)
- (2) Inlet hose (from hydraulic motor)

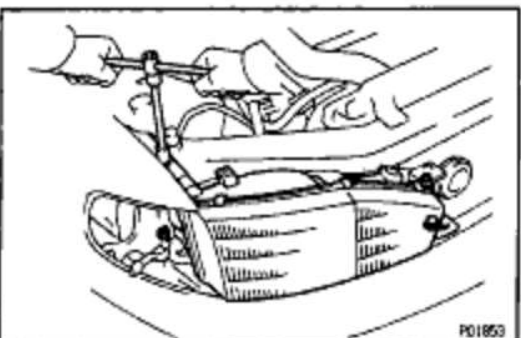

4. INSTALL RH HEADLIGHT ASSEMBLY

(a) Connect the 2 connectors.
(b) Install the headlight assembly with the 3 bolts and nut.

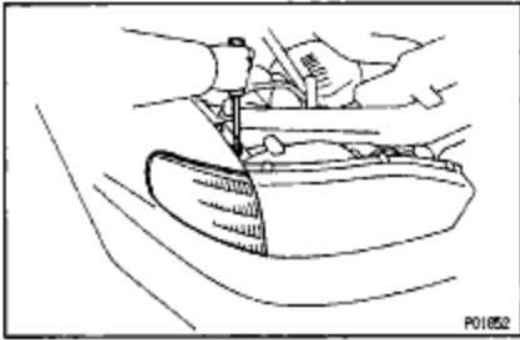
EG2-362**1MZ-FE ENGINE - COOLING SYSTEM****5. INSTALL RH PARKING LIGHT ASSEMBLY**

- (a) Connect the connector.
- (b) Install the parking light assembly with the screw.

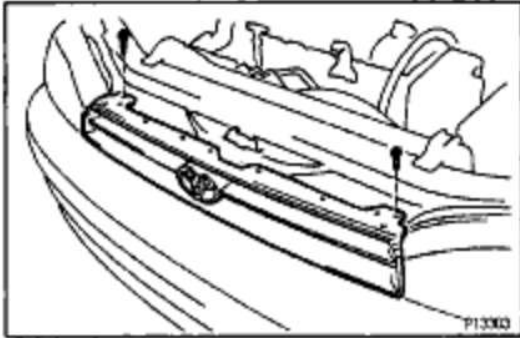
**6. INSTALL RADIATOR GRILLE**

Install the radiator grille with the 2 mounting screws.

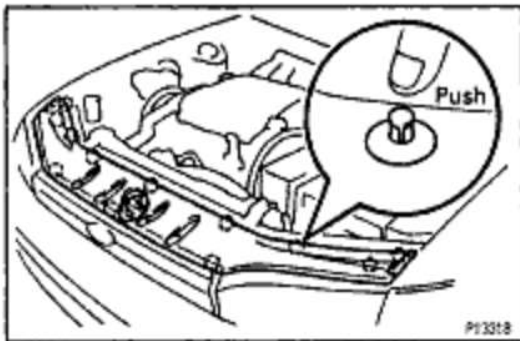
**7. INSTALL UPPER RADIATOR SUPPORT SEAL**

Install the support seal with the 12 clips.

8. FILL PS RESERVOIR TANK WITH FLUID

(See page [EG2-347](#))

9. BLEED ELECTRONICALLY CONTROLLED HYDRAULIC COOLING FAN SYSTEM

(See page [EG2-348](#))

Cooling Fan ECU COMPONENTS FOR REMOVAL AND INSTALLATION

M130-08

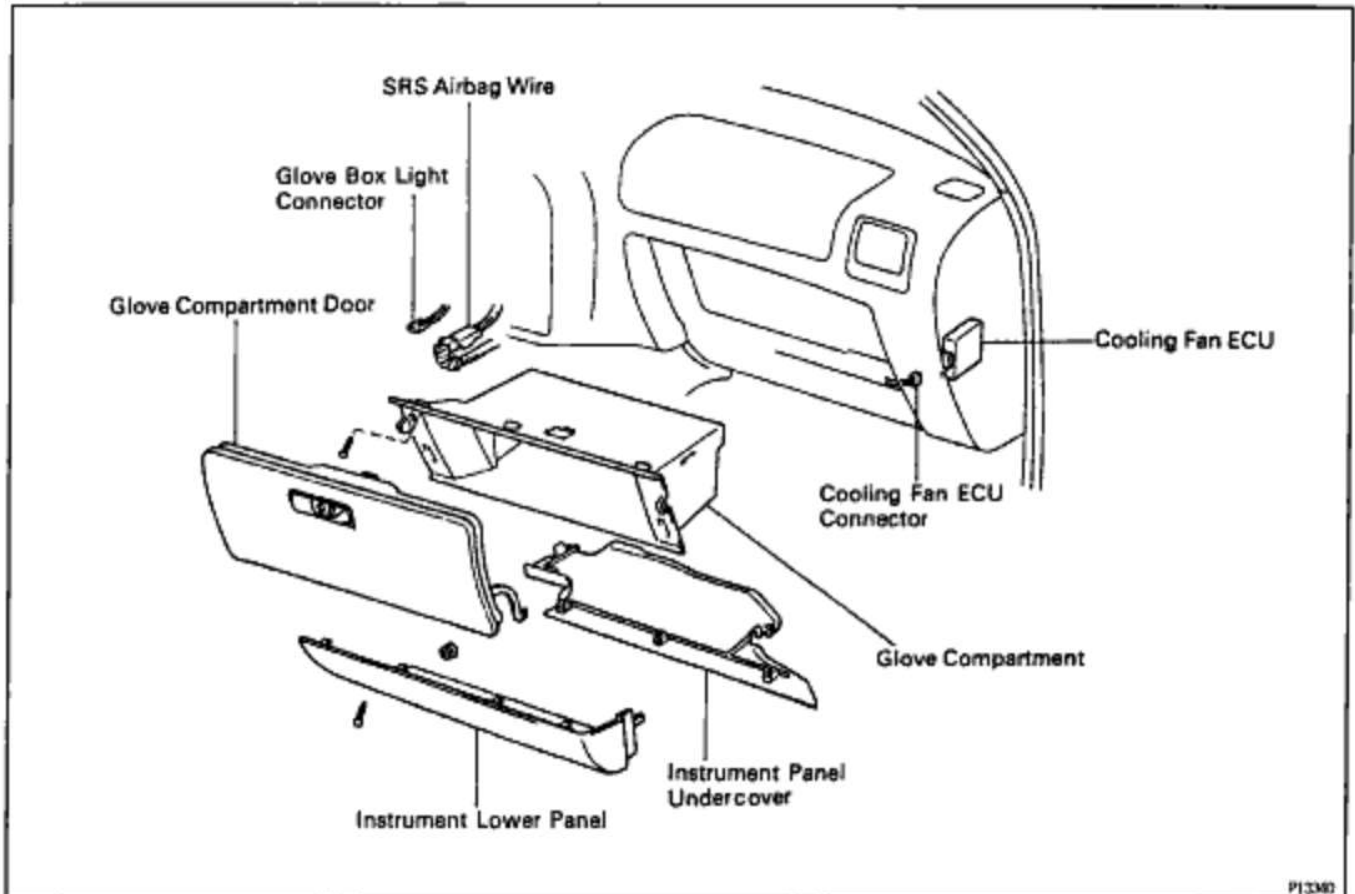

P1330

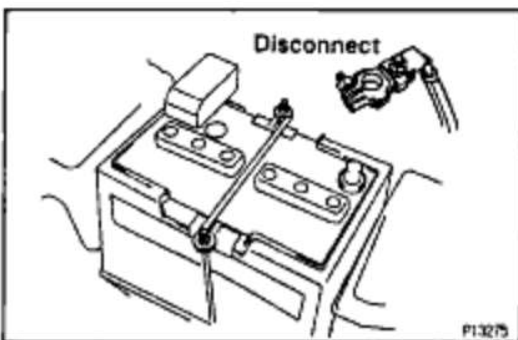

COOLING FAN ECU INSPECTION

M087-01

1. DISCONNECT NEGATIVE (-) TERMINAL CABLE FROM BATTERY

CAUTION: Work must be started after 90 seconds from the time the ignition switch is turned to the 'LOCK' position and the negative (-) terminal cable is disconnected from the battery.

2. DISCONNECT COOLING FAN ECU CONNECTOR (See Components)

- (a) Remove the instrument panel undercover.
- (b) Remove the instrument lower panel.
- (c) Remove the glove compartment door.
- (d) Remove the glove compartment.
- (e) Disconnect the cooling fan ECU connector.

EG2-364

1MZ-FE ENGINE – FE ENGINE – COOLING SYSTEM

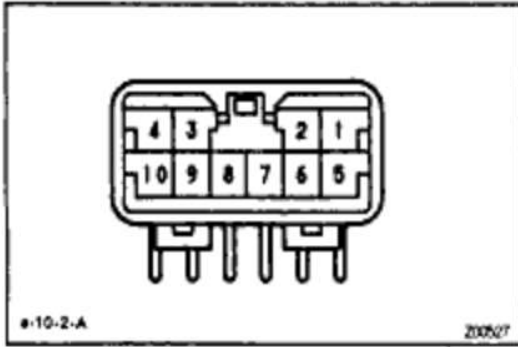

3. INSPECT COOLING FAN ECU

- (a) Connect the cable to the negative (-) terminal of the battery.
- (b) Check the connector on the wiring harness side as shown in the chart.

Check for	Tester connection	Condition	Specified value
Voltage	1 – Ground	Ignition switch ON	Battery voltage
Resistance	2–3	Solenoid valve at cold (25°C (77°F))	7.6 – 8.0Ω
Continuity	4 – Ground	–	Continuity
Continuity	5 – Ground	Throttle valve open	No continuity
		Throttle valve closed	Continuity
Continuity	8 – Ground	A/C pressure SW connector disconnected	No continuity
		A/C pressure SW connector connected	Continuity
Resistance	9–10	Coolant temperature at 80°C (176°F)	1.48 – 1.58 kΩ

v0033;

- (c) Disconnect the cable from the negative (-) terminal of the battery.

- 4. RECONNECT COOLING FAN ECU CONNECTOR**
- 5. RECONNECT NEGATIVE (-) TERMINAL CABLE TO BATTERY**

00001-01

ECT SENSOR INSPECTION

INSPECT ECT SENSOR

Using an ohmmeter, measure the resistance between the terminals.

Resistance:

1.48 – 1.58 Ω at 80° C (176° F)

If the resistance is not as specified, replace the sensor.

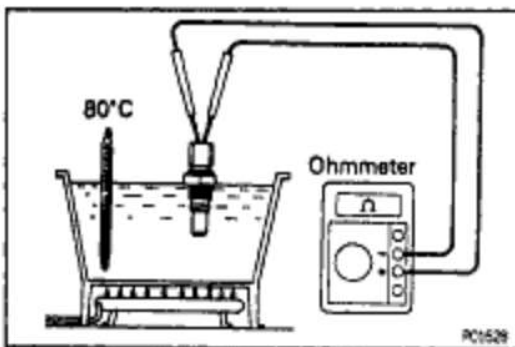

A/C High -Pressure Switch

A/C HIGH-PRESSURE SWITCH INSPECTION

1. DISCONNECT A/C HIGH-PRESSURE SWITCH CONNECTOR
2. INSTALL MANIFOLD GAUGE SET
(See page [AC-23](#))

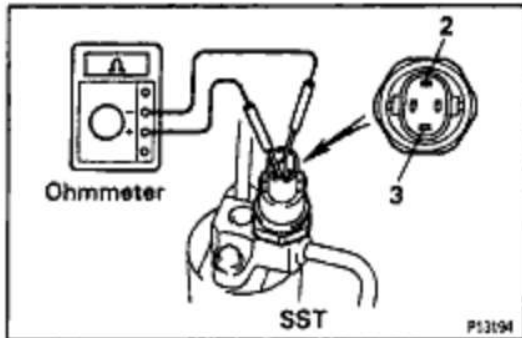

3. INSPECT A/C HIGH-PRESSURE SWITCH

- (a) When the A/C switch is OFF, check that there is continuity between terminals 2 and 3. (When the pressure is 1,226 kPa (12.5 kgf/cm², 178 psi) or lower.)
 - (b) When the A/C and blower switches are ON, check that there is no continuity between terminals 2 and 3. (When the pressure is 1,520 kPa (15.5 kgf/cm², 220 psi) or higher.)
- If continuity is not as specified, replace the switch.

4. REMOVE MANIFOLD GAUGE SET
5. RECONNECT A/C HIGH-PRESSURE SWITCH CONNECTOR

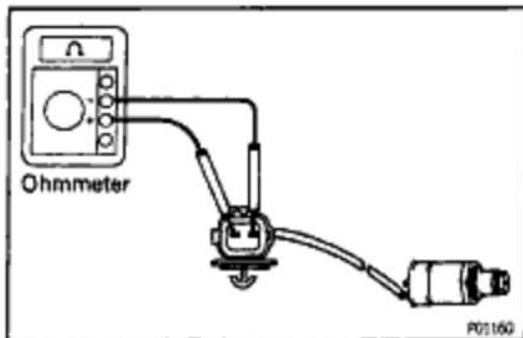

Solenoid Valve

SOLENOID VALVE INSPECTION

INSPECT SOLENOID VALVE

Using an ohmmeter, measure the resistance between the terminals

Resistance:

7.6 – 8.0Ω at 25°C (77°F)

If the resistance is not as specified, replace the solenoid valve.

EG2-366

1MZ-FE ENGINE - COOLING SYSTEM

SERVICE SPECIFICATIONS

SERVICE DATA

8994V-08

Thermostat	Valve opening pressure Valve lift at 95°C (203°F)	80 - 84°C (178 - 183°F) 10.0 mm (0.394 in.) or more
Radiator cap	Relief valve opening pressure (STD) Relief valve opening pressure (Limit)	83 - 113 kPa (0.85 - 1.15 kgf/cm ² , 12.1 - 16.4 psi) 69 kPa (0.7 kgf/cm ² , 10.0 psi)
Radiator	Plate height	7.75 - 8.25 mm (0.3051 - 0.3248 in.)
On-vehicle inspection for hydraulic-driven cooling motor	Oil pressure	981 - 1,961 kPa (10 - 20 kgf/cm ² , 142 - 284 psi)
Hydraulic motor	Rotor side clearance (STD) Rotor side clearance (Limit) Drive shaft hole inside diameter Drive shaft diameter Drive shaft oil clearance (STD) Drive shaft oil clearance (Limit) Drive shaft preload (rotating torque)	0.01 - 0.04 mm (0.0004 - 0.0016 in.) 0.05 mm (0.0020 in.) 14.000 - 14.011 mm (0.5512 - 0.5516 in.) 13.973 - 13.984 mm (0.5501 - 0.5506 in.) 0.016 - 0.038 mm (0.0006 - 0.0015 in.) 0.04 mm (0.0031 in.) 0.03 N·m (3.0 kgf·cm, 2.6 in.-lbf)
ECT sensor	Resistance at 80°C (176°F)	1.48 - 1.58 kΩ

TORQUE SPECIFICATIONS

8994V-08

Part tightened	N·m	kgf·cm	ft·lbf
RH Drain plug x Cylinder block	7	70	61 in.-lbf
LH Drain plug x Cylinder block	13	130	9
Water pump x Cylinder block	8	80	69 in.-lbf
No.3 timing belt cover x Cylinder head	8.5	85	74 in.-lbf
No.2 idler pulley x Cylinder heads	43	440	32
Camshaft pulley x Camshaft	125	1,300	94
Camshaft pulley x Camshaft (For use with SST)	88	900	65
Water inlet x Water inlet housing	8	80	69 in.-lbf
Water inlet pipe x LH cylinder head	19.5	200	14
Hydraulic motor pressure hose x Water inlet	8	80	69 in.-lbf
Radiator oil cooler x Radiator lower tank	8.3	85	7.4 in.-lbf
Radiator pipe x Radiator lower tank	14.7	150	11
Pressure hose x Hydraulic motor	63.7	650	47
Radiator support bolt	12.6	130	9
Hydraulic motor housing x Motor cover	28	280	21
Hydraulic motor x Fan shroud	4.9	50	43 in.-lbf
Cooling fan x Hydraulic motor	15	150	11
Hydraulic cooling fan x Radiator	4.9	50	43 in.-lbf
Oil cooler (for hydraulic cooling fan) x Radiator lower support	6	60	69 in.-lbf