

AUTOMATIC TRANSMISSION

REFER TO LAND CRUISER (STATION WAGON)
REPAIR MANUAL FOR CHASSIS AND BODY
(Pub. No. RM184E)

NOTE: The following pages contain only the points which differ from the above listed manual.

(STATION WAGON)

DESCRIPTION..... AT-2
 OPERATION..... AT-4
 PREPARATION..... AT-12
 TROUBLESHOOTING..... AT-14
 VALVE BODY..... AT-58
 THROTTLE CABLE..... AT-63
 ASSEMBLY REMOVAL AND
 INSTALLATION..... AT-66
 SERVICE SPECIFICATIONS..... AT-86



DESCRIPTION

GENERAL DESCRIPTION

The A442F automatic transmission is a four-speed automatic transmission with a four-speed transfer, developed with the aim of producing an easy-driving 4WD vehicle. A lock-up mechanism is built into the torque converter.

The A442F transmission is mainly composed of the torque converter, the overdrive (hereafter called O/D) planetary gear unit, 3-speed planetary gear unit, 4-speed transfer, hydraulic control system and an electronic control system.

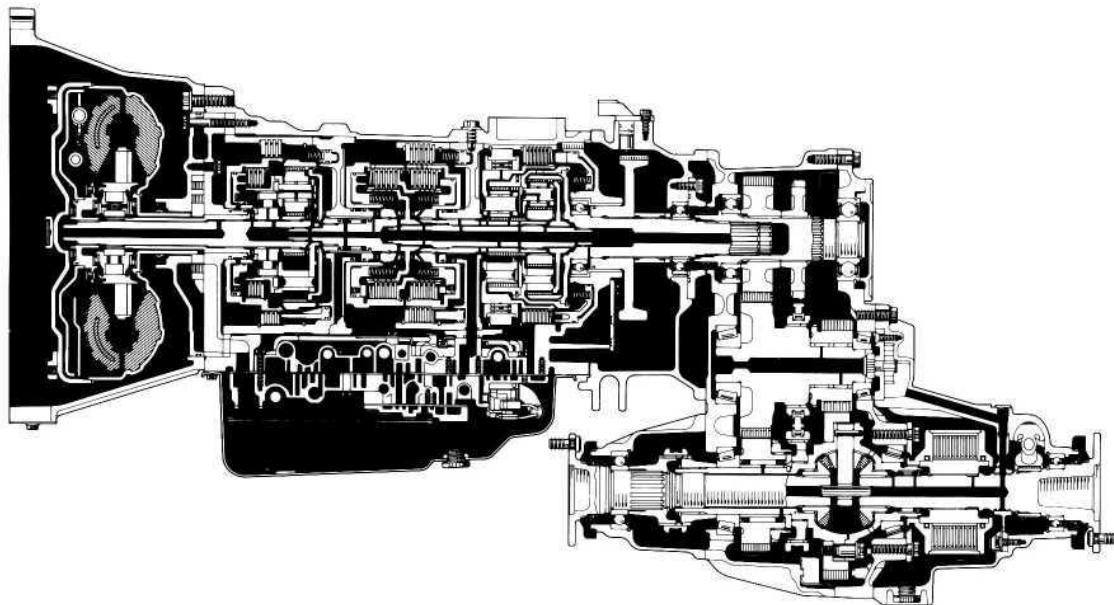

GENERAL SPECIFICATIONS

Type of Transmission		A442F	←
Type of Engine		1FZ-FE	1HD-T
Torque Converter Stall Torque Ratio		1.8 : 1	2.0 : 1
Lock-up Mechanism		Equipped	←
Gear Ratio	1st Gear	2.950	←
	2nd Gear	1.530	←
	3rd Gear	1.000	←
	O/D Gear	0.765	←
	Reverse Gear	2.678	←
Number of Discs and Plates (Disc and Plate)	Front Clutch (C ₁)	6/6	7/7
	Rear Clutch (C ₂)	5/5	←
	O/D Direct Clutch (C ₀)	3/3	←
	2nd Brake (B ₁)	5/5	←
	1st and Reverse Brake (B ₂)	6/6	←
	O/D Brake (B ₀)	3/3	←
ATF Type		ATF DEXRON® II	←
Capacity (US pts, Imp. qts)	Total		
	w/ Oil Cooler	15.4 (16.3, 13.6)	←
	w/o Oil Cooler	15.0 (15.9, 13.2)	←
	Drain & Refill	6.0 (6.3, 5.3)	←

OPERATION

OPERATION

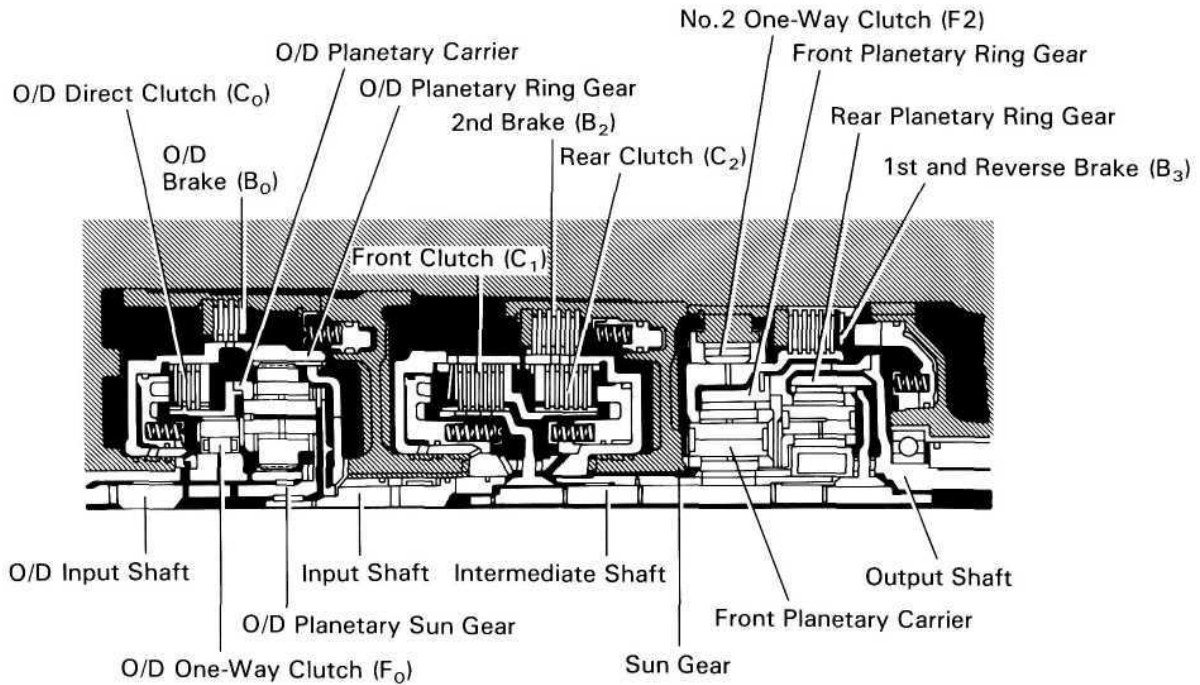

Q03056

○....Operating

Shift lever position	Gear position	C ₀	C ₁	C ₂	B ₀	B ₂	B ₃	F ₀	F ₂
P	Parking	○						○	
R	Reverse	○		○			○	○	
N	Neutral	○						○	
D	1st	○	○					○	○
	2nd		○			○		○	
	3rd	○	○	○				○	
	O/D		○	○	○				
2	2nd	○	○			○		○	
L	1st	○	○				○	○	○

1. FUNCTION OF COMPONENTS

COMPONENT	FUNCTION
O/D Direct Clutch (C ₀)	Connects overdrive sun gear and overdrive carrier
O/D Brake (B ₀)	Prevents overdrive sun gear from turning either clockwise or counterclockwise
O/D One-Way Clutch (F ₀)	When transmission is being driven by engine, connects overdrive sun gear and overdrive carrier
Front Clutch (C ₁)	Connects input shaft and intermediate shaft
Rear Clutch (C ₂)	Connects input shaft and front & rear planetary sun gear
2nd Brake (B ₁)	Prevents front & rear planetary sun gear from turning either clockwise or counterclockwise
1st & Reverse Brake (B ₂)	Prevents front planetary carrier from turning either clockwise or counterclockwise
No.2 One-Way Clutch (F ₂)	Prevents front planetary carrier from turning counterclockwise

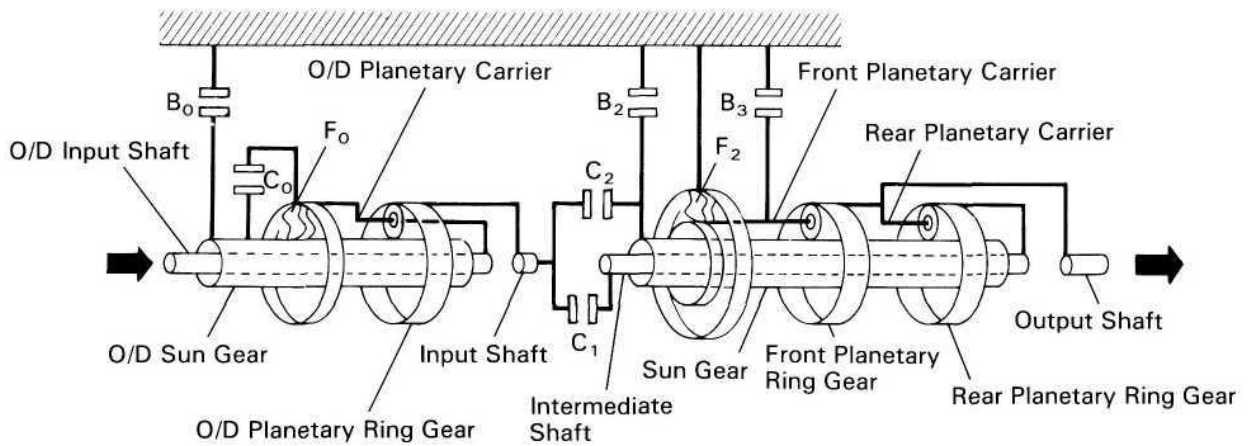

The conditions of operation for each gear position are shown on the following illustration:

D Range 1st Gear

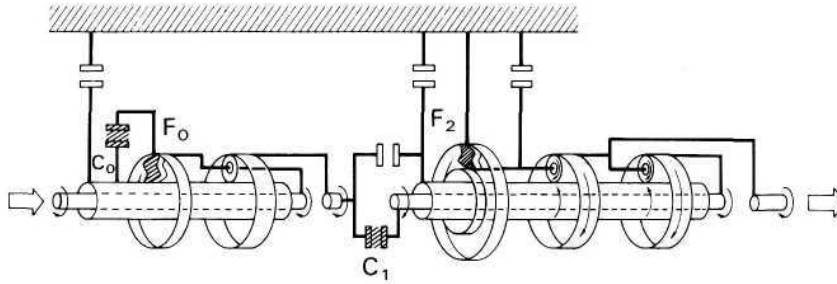

AT5949

D Range 2nd Gear

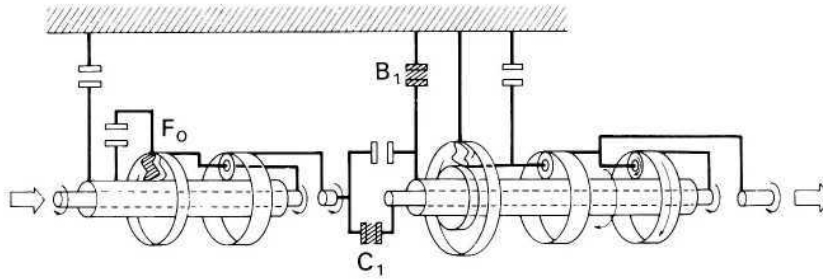

AT5950

D Range 3rd Gear

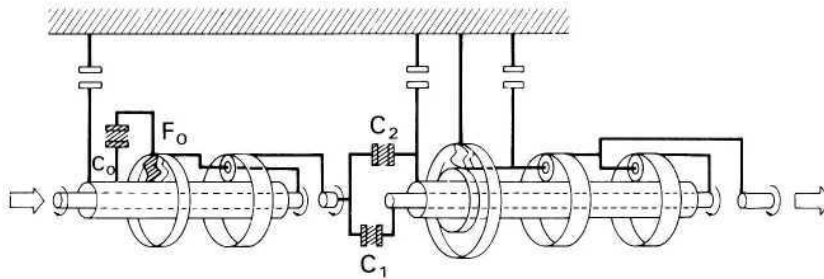

AT5951

D Range O/D

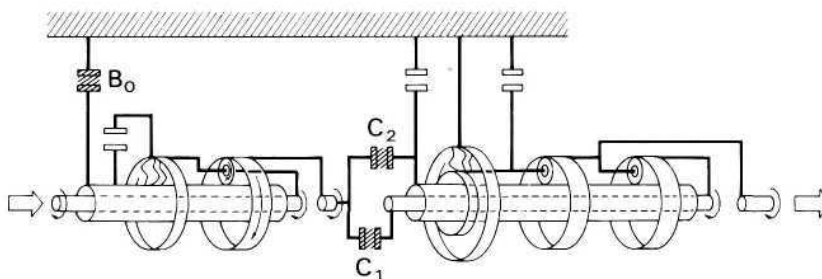

AT5952

2 Range 2nd Gear

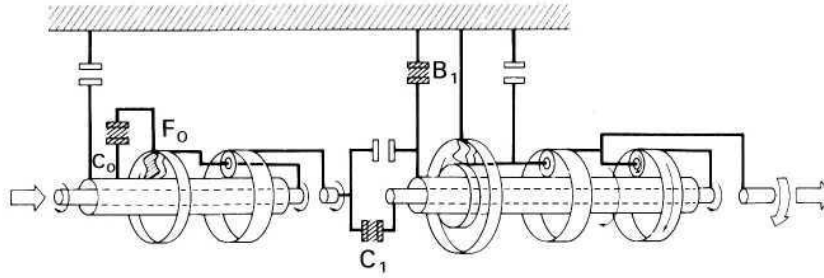

AT5953

L Range 1st Gear

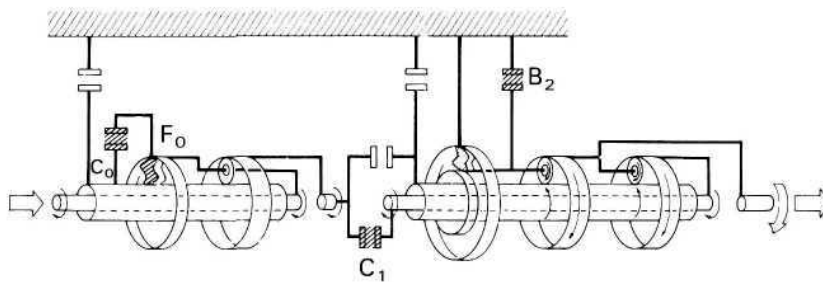

AT5954

R Range Reverse Gear

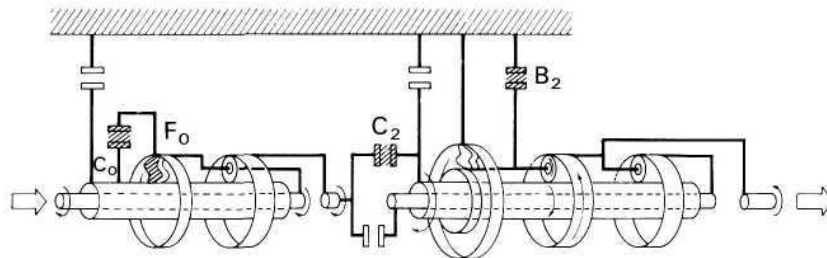

AT5955

2. HYDRAULIC CONTROL SYSTEM

The hydraulic control system is composed of the oil pump, the valve body, the solenoid valves, the accumulators, the clutches and brakes, as well as the fluid passages which connect all of these components.

Based on the hydraulic pressure created by the oil pump, the hydraulic control system governs the hydraulic pressure acting on the torque converter, clutches and brakes in accordance with the vehicle driving condition.

There are four solenoid valves on the valve body.

These solenoid valves are turned on and off by signals from ECU to operate the shift valves.

These shift valves then switch the fluid passages so that fluid goes to the torque converter and planetary gear units.

(Except for the solenoid valves, the hydraulic control system of the electronically controlled transmission (hereafter called ECT) is basically the same as that of the fully hydraulic controlled automatic transmission.)

HYDRAULIC CONTROL SYSTEM

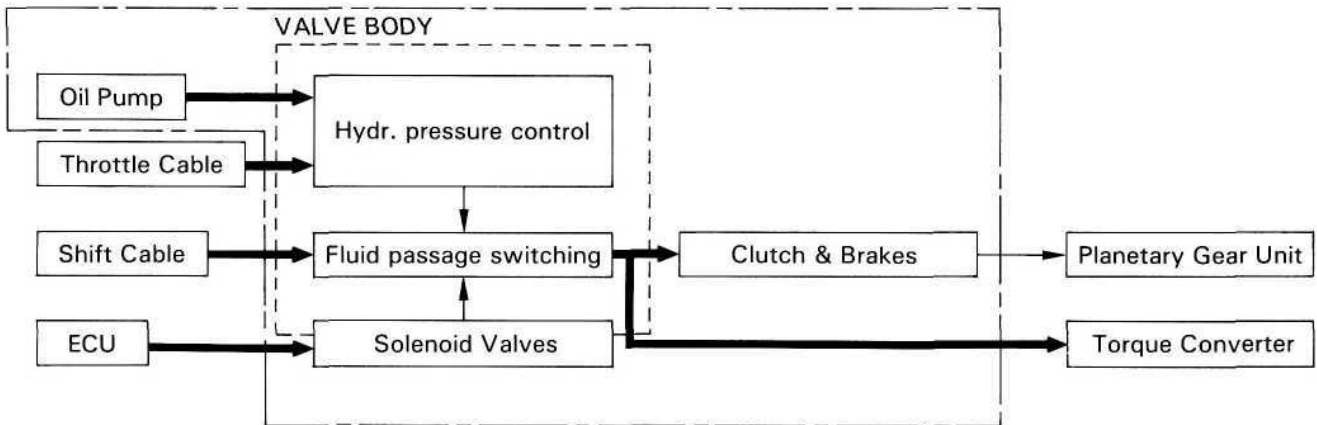

3. ELECTRONIC CONTROL SYSTEM

The electronic control system for the A442F automatic transmission provide extremely precise control of the gear shift timing and lock-up timing in response to driving conditions as sensed by various sensors located throughout the vehicle and in response to the engine's running condition.

At the same time, the ECT ECU control reduces vehicle squat when the vehicle starts out and gear shift shock.

The electronic control system for controlling the shift timing and the operation of the lock-up clutch is composed of the following three parts:

- (a) Sensors: These sense the vehicle speed and throttle position and send this data to the ECT ECU in the form of electronic signals.
- (b) ECT ECU: This determines the shift and lock-up timing based upon the signals from the sensors.
- (c) Actuators: Solenoid valves divert hydraulic pressure from one circuit of the hydraulic control unit to another thus controlling shifting and lock-up timing.

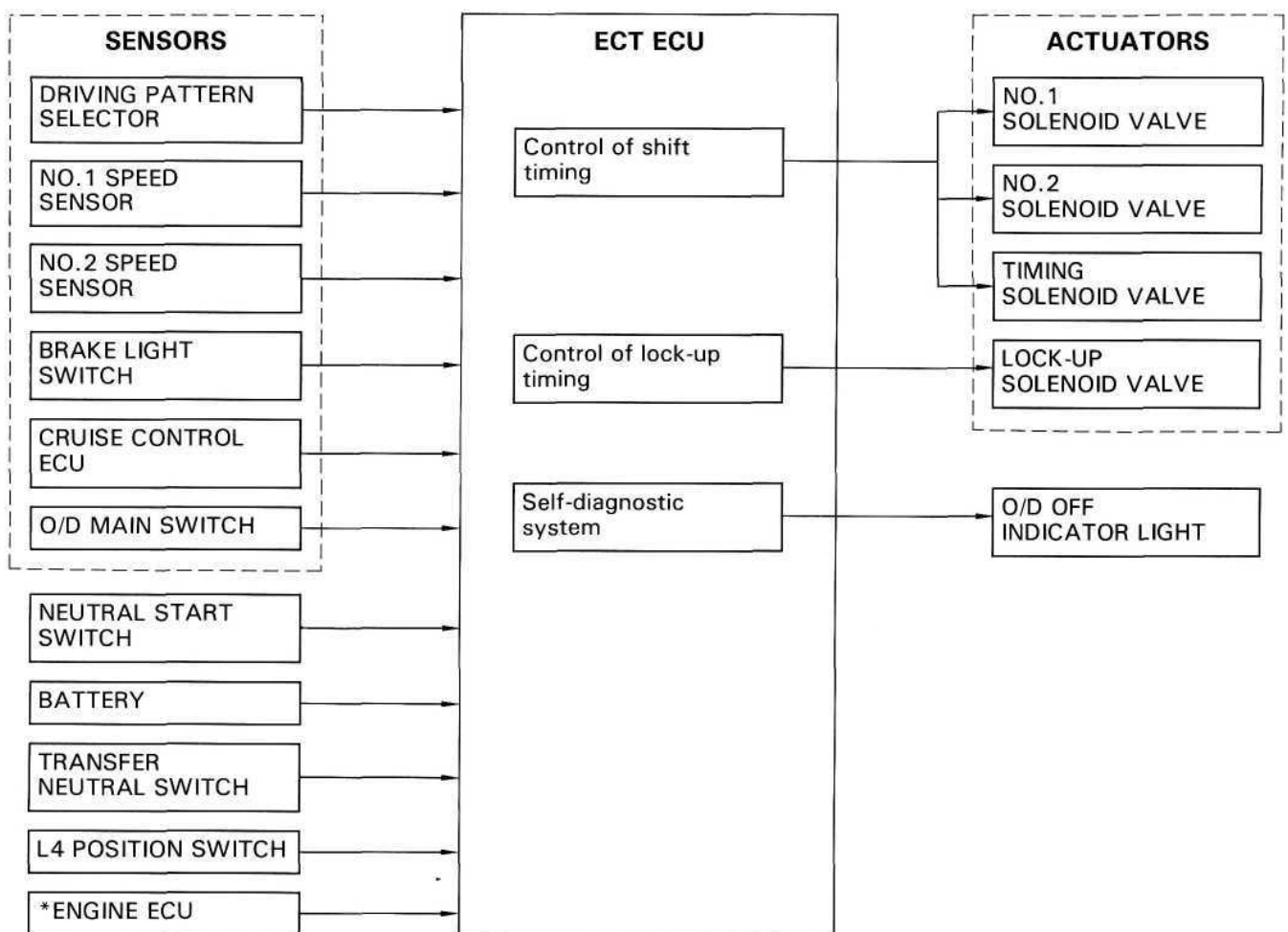

*: 1FZ-FE engine only

4. FUNCTION OF TCM

- **Control of Shift Timing**

The ECU has programmed into its memory the optimum shift pattern for each shift lever position (D, 2, L ranges) and driving mode (Normal or Power).

Based on the appropriate shift pattern, the ECU turns No.1, No.2 and timing solenoid valves on or off in accordance with the vehicle speed signal from the speed sensor and the throttle opening signal from the throttle position sensor. In this manner, the ECU operates each shift valve, opening or closing the fluid passages to the clutches and brakes to permit up-shift or down-shift of the transmission.

HINT: The electronic control system provides shift timing and lock-up control only while the vehicle is traveling forward. In REVERSE, and NEUTRAL, the transmission is mechanically, not electronically controlled.

- **Control of Overdrive**

Driving in overdrive is possible if the O/D main switch is on and the shift lever is in the D range. However, when the vehicle is being driven using the cruise control system (CCS), if the actual vehicle speed drops to about 4 km/h (2 mph) below the set speed while the vehicle is running in overdrive, the CCS ECU sends a signal to the ECT ECU to release the overdrive and prevent the transmission from shifting back into overdrive until the actual vehicle speed reaches the speed set in the CCS memory.

On this model, if the coolant temperature falls below 55°C (131 °F), the engine ECU sends a signal to the ECT ECU, preventing the transmission from up-shifting into overdrive.

- **Control of Lock-Up System**

The ECT ECU has programmed in its memory a lock-up clutch operation pattern for each driving mode (Normal or Power). Based on this lock-up pattern, the ECU turns lock-up solenoid valve on or off in accordance with the vehicle speed signals received from the speed sensor and the throttle opening signals from the the throttle position sensor.

Depending on whether lock-up solenoid valve is on or off, the lock-up relay valve performs changeover of the fluid passages for the converter pressure acting on the torque converter to engage or disengage the lock-up clutch.

(Mandatory Cancellation of Lock-Up System)

If any of the following conditions exist, the ECU turns off lock-up solenoid valve to disengage the lock-up clutch.

- (1) The brake light switch comes on (during braking).
- (2) The IDL points of the throttle position sensor close (throttle valve fully closed.).
- (3) The vehicle speed drops 4 km/h (2 mph) or more below the set speed while the cruise control system is operating.
- (4) The coolant temperature falls below 70°C (158°F).

The purpose of (1) and (2) above is to prevent the engine from stalling if the rear wheels lock up.

The purpose of (3) is to cause the torque converter operate to obtain torque multiplication.

The purpose of (4) is both to improve general driveability, and to speed up transmission warm-up.

Also, while the lock-up system is in operation, the ECU will temporarily turn it off during up-shift or down-shift in order to decrease shifting shock.

5. A/T. FLUID TEMPERATURE WARNING SYSTEM

The ECT ECU detects the A/T fluid temperature by means of a fluid temperature sensor fitted to the union. The A/T fluid may become extremely when the vehicle is under and extreme load, as when driving on sand or climbing uphill. Should the fluid temperature increase above 150°C (302°F), the ECT ECU lights the warning light located in the combination meter. The light goes off when temperature falls below 120°C (248°F).

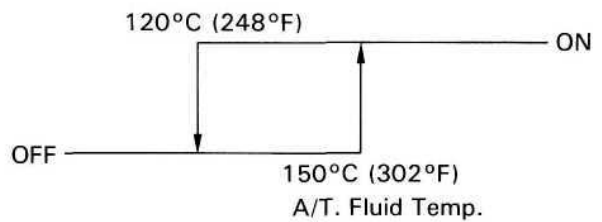
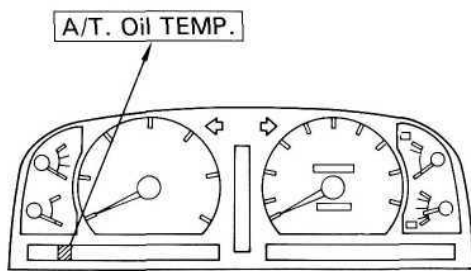

AT6023

V01585





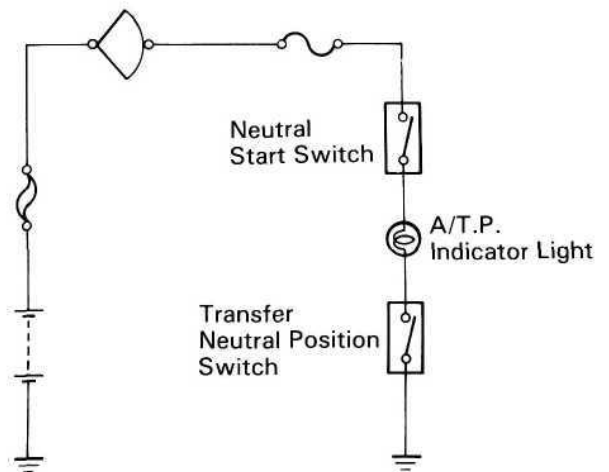
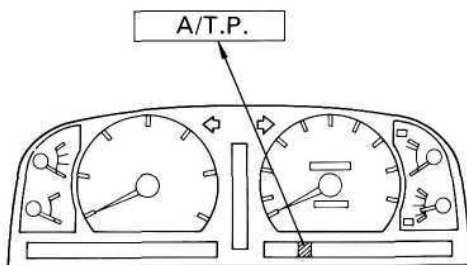

6. A/T. P. (Automatic Transmission Parking) INDICATOR

The propeller shaft and wheels are free even when the transmission shift lever is set to "P" as long as the transfer shift lever is in "neutral" position. The A/T.P. indicator lights up to warn the driver that the propeller shaft and wheels are not locked. If the A/T.P. indicator light goes on, the transfer shift lever should be shifted to out of "N" position.



AT6024 AT3920

PREPARATION**SST (SPECIAL SERVICE TOOLS)**

	09032-00100	Oil Pan Seal Cutter	
	09350-30020	TOYOTA Automatic Transmission Tool Set	
	(09351-32010)	One-way Clutch Test Tool	
	(09351-32020)	Stator Stopper	
	09843-18020	Diagnosis Check Wiring	
	09992-00094	Automatic Transmission Oil Pressure Gauge Set	

EQUIPMENT

Ohmmeter	
Voltmeter	
Torque wrench	
Dial indicator with magnetic base	Check drive plate runout.
Vernier calipers	Check torque converter installation.
Straight edge	Check torque converter installation.

LUBRICANT

Item	Capacity	Classification
Automatic transmission fluid Dry fill w/ Oil cooler w/o Oil cooler Drain and refill	15.4 liter (16.3 US qts, 13.6 Imp.qts) 15.0 liter (15.9 US qts, 13.2 Imp.qts) 6.0 liters (6.3 US qts, 5.3 Imp.qts)	ATF DEXRON® II

SSM (SPECIAL SERVICE MATERIALS)

08826-00090 Seal Packing 1281, Three bond 1281 or equivalent	Oil pan
---	---------

TROUBLESHOOTING

Trouble occurring in the ECT can stem from one of three sources: the engine, the ECT electronic control unit or the transmission itself. Before troubleshooting, determine in which these three sources the problem lies, and begin troubleshooting with the simplest operation, gradually working up in order or difficulty.

BASIC TROUBLESHOOTING

Before troubleshooting an ECT, first determine whether the problem is electrical or mechanical. To do this, just refer to the basic troubleshooting flow-chart provided below.

If the cause is already known, using the basic troubleshooting chart below along with the general troubleshooting chart on the following pages should speed the procedure.

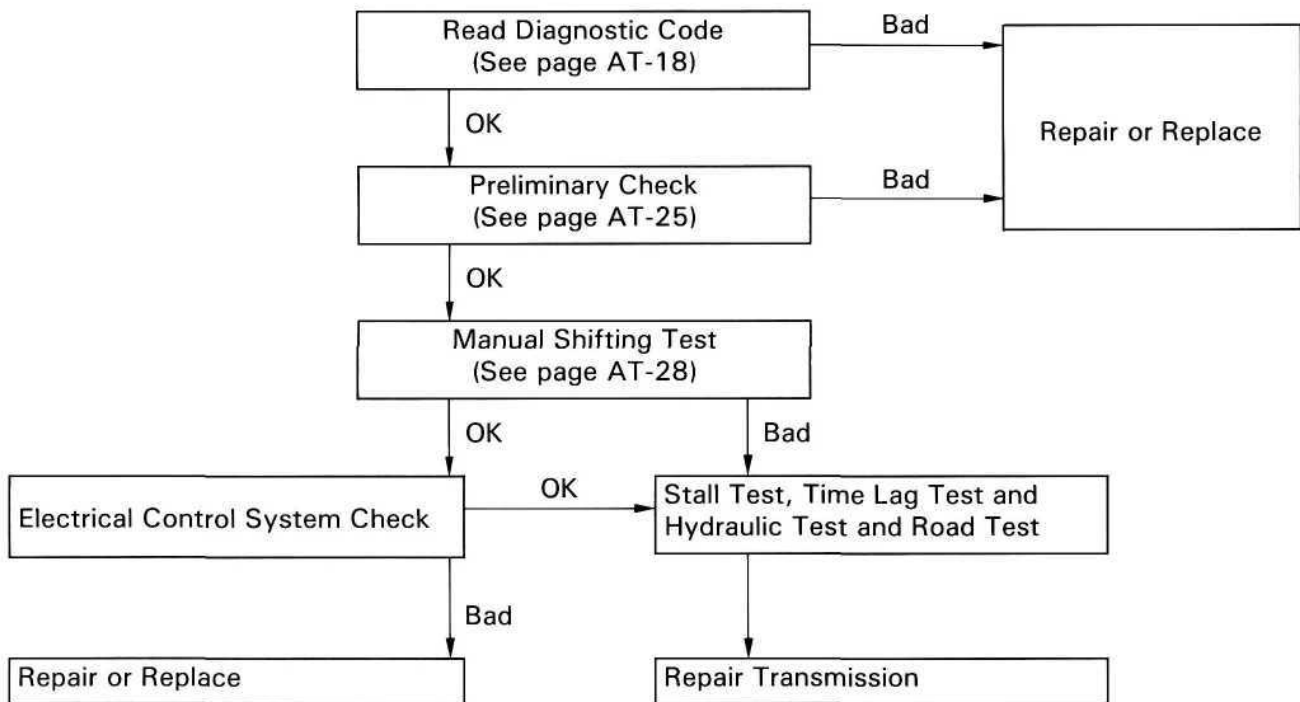

NOTICE: Refer to A442F Automatic Transmission Repair Manual (Pub. No. RM314E) when ★ mark appears in the column for page numbers.

Problem	Possible cause	Remedy	Page
Fluid discolored or smells burnt	Fluid contaminated	Replace fluid	AT-25
	Torque converter faulty	Replace torque converter	AT-76
	Transmission faulty	Disassemble and inspect transmission	★
Vehicle does not move in any forward range or reverse	Manual linkage out of adjustment	Adjust linkage	AT-26
	Valve body or primary regulator faulty	Inspect valve body	★
	Parking lock pawl faulty	Inspect parking lock pawl	★
	Torque converter faulty	Replace torque converter	AT-76
	Converter drive plate broken	Replace drive plate	AT-76
	Oil pump intake screen blocked	Clean screen	★
	Transmission faulty	Disassemble and inspect transmission	★
Shift lever position incorrect	Manual linkage out of adjustment	Adjust linkage	AT-26
	Manual valve and lever faulty	Inspect valve body	★
	Transmission faulty	Disassemble and inspect transmission	★
Harsh engagement into any drive position	Throttle cable out of adjustment	Adjust throttle cable	AT-26
	Valve body or primary regulator faulty	Inspect valve body	★
	Accumulator pistons faulty	Inspect accumulator pistons	★
	Transmission faulty	Disassemble and inspect transmission	★
Delayed 1 – 2, 2 – 3 or 3 – O/D up-shift, or down-shift from O/D – 3 or 3 – 2 and shifts back to O/D or 3	Electronic control faulty	Inspect electronic control	AT-29
	Valve body faulty	Inspect valve body	★
	Solenoid valve faulty	Inspect solenoid valve	AT-40
Slips on 1 – 2, 2 – 3 or 3 – O/D up-shift, or shps or shudders on acceleration	Manual linkage out of adjustment	Adjust linkage	AT-26
	Throttle cable out of adjustment	Adjust throttle cable	AT-26
	Valve body faulty	Inspect valve body	★
	Solenoid valve faulty	Inspect solenoid valve	AT-40
	Transmission faulty	Disassemble and inspect transmission	★
Drag, binding or tie-up on 1 – 2, 2 – 3 or 3 – O/D up-shift	Manual linkage out of adjustment	Adjust linkage	AT-26
	Valve body faulty	Inspect valve body	★
	Transmission faulty	Disassemble and inspect transmission	★

NOTICE: Refer to A442F Automatic Transmission Repair Manual (Pub. No. RM314E) when ★ mark appears in the column for page numbers.

Problem	Possible cause	Remedy	Page
No lock-up in 3rd or O/D	Electronic control faulty	Inspect electronic control	AT-29
	Valve body faulty	Inspect valve body	★
	Solenoid valve faulty	Inspect solenoid valve	AT-40
	Transmission faulty	Disassemble and inspect transmission	★
Harsh down-shift	Throttle cable out of adjustment	Adjust throttle cable	AT-26
	Throttle cable and cam faulty	Inspect throttle cable and cam	AT-26
	Accumulator pistons faulty	Inspect accumulator pistons	★
	Valve body faulty	Inspect valve body	★
	Transmission faulty	Disassemble and inspect transmission	★
No down-shift when coasting	Valve body faulty	Inspect valve body	★
	Solenoid valve faulty	Inspect solenoid valve	AT-40
	Electronic control faulty	Inspect electronic control	AT-29
Down-shift occurs too quickly or too late while coasting	Throttle cable faulty	Inspect throttle cable	AT-26
	Valve body faulty	Inspect valve body	★
	Transmission faulty	Disassemble and inspect transmission	★
	Solenoid valve faulty	Inspect solenoid valve	AT-40
	Electronic control faulty	Inspect electronic control	AT-29
No O/D — 3, 3 — 2 or 2 — 1 kick-down	Solenoid valve faulty	Inspect solenoid valve	AT-40
	Electronic control faulty	Inspect electronic control	AT-29
	Valve body faulty	Inspect valve body	★
No engine braking 2 or L range	Solenoid valve faulty	Inspect solenoid valve	AT-40
	Electronic control faulty	Inspect electronic control	AT-29
	Valve body faulty	Inspect valve body	★
	Transmission faulty	Disassemble and inspect transmission	★
Vehicle does not hold in P	Manual linkage out of adjustment	Adjust linkage	AT-26
	Parking lock pawl cam and spring faulty	Inspect cam and spring	AT-26

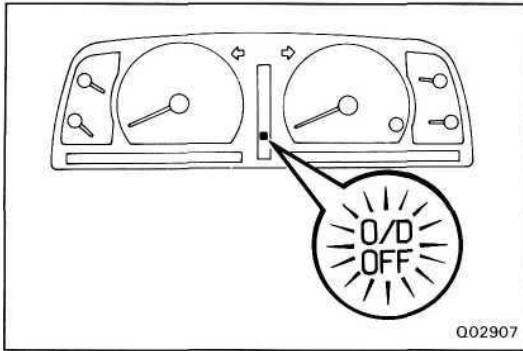

DIAGNOSIS SYSTEM

DESCRIPTION

1. A self-diagnosis function is built into the electrical control system. Warning is indicated by the overdrive OFF indicator light.

HINT: Warning and diagnostic codes can be read only when the overdrive switch is ON. If OFF, the overdrive OFF light is lit continuously and will not blink.

- (a) If a malfunction occurs within the speed sensors (No.1 or 2), throttle sensor or engine speed signal, the overdrive OFF indicator light will blink to warn the driver.

However, there will be no warning of a malfunction with lock-up solenoid.

- (b) The diagnostic code can be read by the number of blinks of the overdrive OFF indicator light when terminals T_T and ET are connected. (See page AT-20)
- (c) The throttle position sensor or brake signal are not indicated, but inspection can be made by checking the voltage at terminal T_T of the check connector.
- (d) The signals to each gear can be checked by measuring the voltage at terminal T_T of the check connector while driving.

2. The diagnostic code is retained in memory by the ECT ECU and due to back-up voltage, is not canceled out when the engine is turned off. Consequently, after repair, it is necessary to turn the ignition switch off and remove the DOME fuse (10 A) or disconnect the ECT ECU connector to cancel out the diagnostic code. (See page AT-20)

HINT:

- Low battery voltage will cause faulty operation of the diagnosis system. Therefore, always check the battery first.
- Use a voltmeter and ohmmeter that have an impedance of at least 10 k Ω /V.

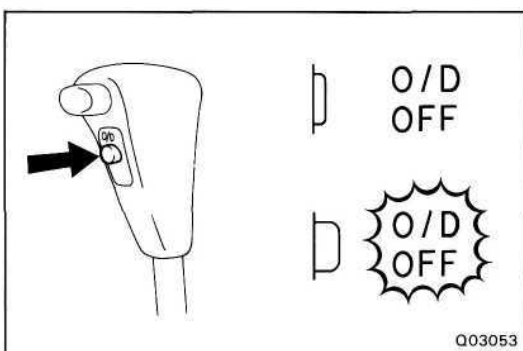
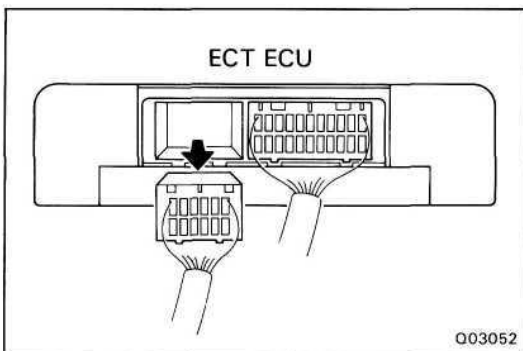
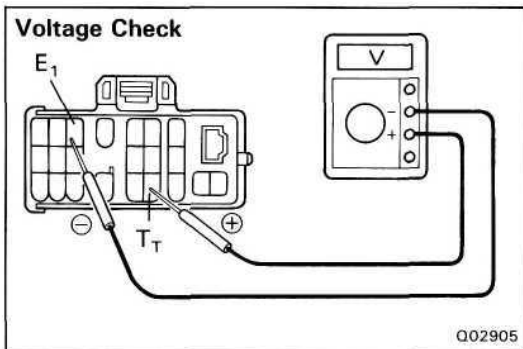
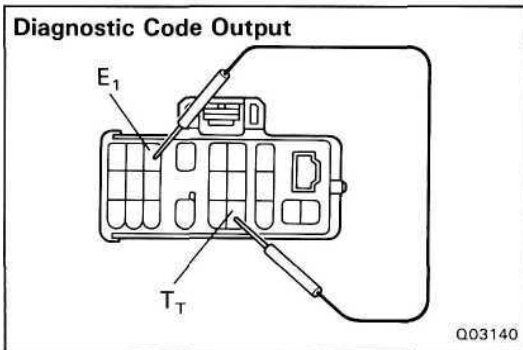

CHECK "O/D OFF" INDICATOR LIGHT

1. Turn the ignition switch ON.
2. The "O/D OFF" light will come on when the O/D switch is placed at OFF.
3. When the O/D switch is set to ON, the "O/D OFF" light should go out.

If the "O/D OFF" light flashes when the O/D switch is set to ON, the electronic control system is faulty.

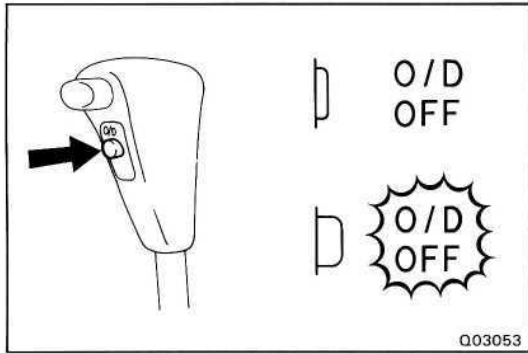

READ DIAGNOSTIC CODE

1. TURN IGNITION SWITCH AND O/D SWITCH TO ON

Do not start the engine.

HINT: Warning and diagnostic codes can be read only when the overdrive switch is ON. If OFF, the overdrive OFF light will light continuously and will not blink.

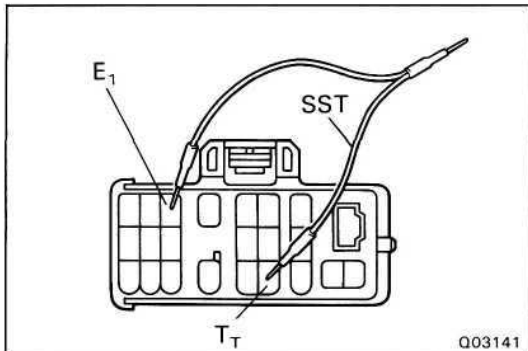

2. CONNECT T_T AND E₁ TERMINALS OF CHECK CONNECTOR

Using SST, connect terminals T_T and E₁ of the check connector.

SST 09843-18020

3. READ DIAGNOSTIC CODE

Read the diagnostic code as indicated by the number of times the O/D OFF light flashes.

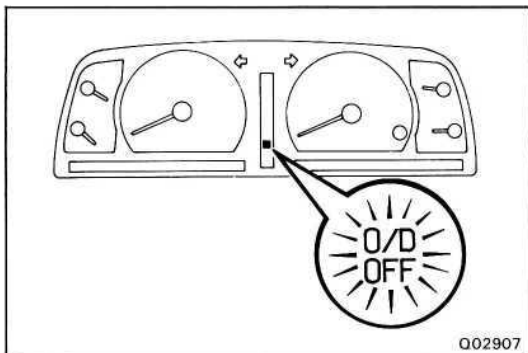

(Diagnostic Code Indication)





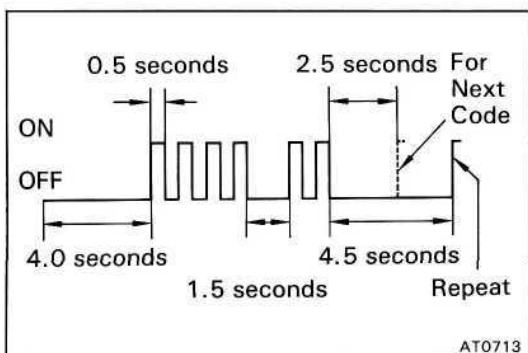
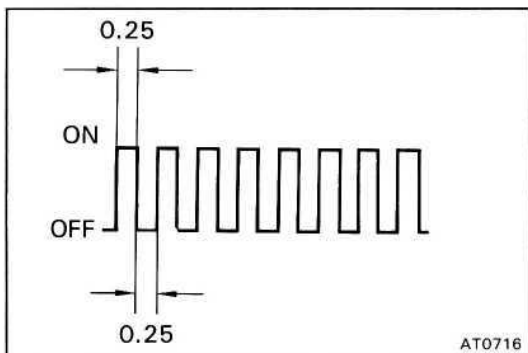

- If the system is operating normally, the light will flash 2 times per second.
- In the event of a malfunction, the light will flash 1 time per second. The number of blinks will equal the first number and, after 1.5 seconds pause, the second number of the two digit diagnostic code. If there are two or more codes, there will be a 2.5 seconds pause between each.

HINT: In the event of several trouble codes occurring simultaneously, indication will begin from the smaller value and continue to the larger.

4. REMOVE SST

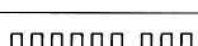
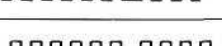
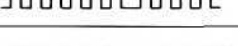

DIAGNOSTIC CODES

Code No.	Light Pattern	Diagnosis System
—		Normal
41		Severed throttle position sensor or short circuit— severed wire harness or short circuit
42		Defective No. 1 speed sensor (in combination meter)— severed wire harness or short circuit
61		Defective No. 2 speed sensor (in ATM)— severed wire harness or short circuit
62		Severed No. 1 solenoid or short circuit— severed wire harness or short circuit
63		Severed No. 2 solenoid or short circuit— severed wire harness or short circuit
64		Severed lock-up solenoid or short circuit— severed wire harness or short circuit
65		Severed timing solenoid or short circuit— severed wire harness or short circuit
86		Severed engine speed sensor or short circuit— severed wire harness or short circuit
*88		Severed engine ECU and ECT ECU or short circuit— severed wire harness or short circuit

*: 1FZ-FE engine only

Q03076

HINT: If codes 62, 63, 64, or 65 appear, there is an electrical malfunction in the solenoid. Causes due to mechanical failure, such as a stuck valve, will not appear.

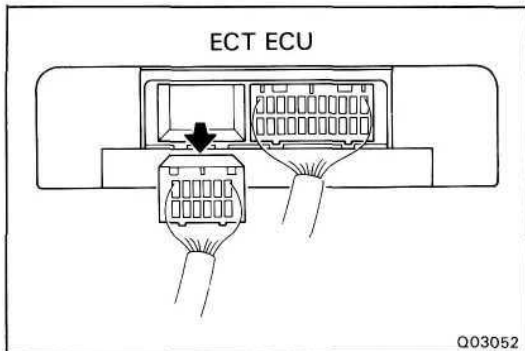
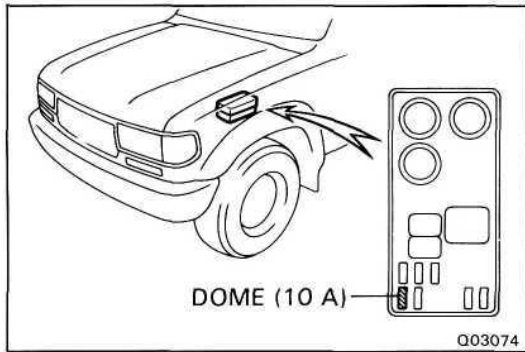

CANCEL OUT DIAGNOSTIC CODE

1. After repair of the trouble area, the diagnostic code retained in memory by the ECT ECU must be canceled by removing the DOME fuse (10 A) for 10 seconds or more, depending on ambient temperature (the lower the temperature, the longer the fuse must be left out) with the ignition switch OFF.

HINT:

- Cancellation can be also done by removing the battery negative (—) terminal, but in this case other memory systems will be also canceled out.
 - The diagnostic code can be also canceled out by disconnecting the ECT ECU connector.
 - If the diagnostic trouble is not canceled out, it will be retained by the ECT ECU and appear along with a new code in event of future trouble.
2. After cancellation, perform a road test to confirm that a "normal code" is now read on the O/D OFF light.

TROUBLESHOOTING FLOW-CHART

HINT:

- If diagnostic code Nos.41, 42, 61, 62, 63, 64, 65, 86, 88 (1FZ-FE engine only) and are output, the overdrive OFF indicator light will begin to blink immediately to warn the driver. However, an impact or shock may cause the blinking to stop; but the code will still be retained in the ECT ECU memory until canceled out.
- There is no warning for diagnostic code No.64 and 65.
- In the event of a simultaneous malfunction of both No.1 and No.2 speed sensors, no diagnostic code will appear and the fail-safe system will not function. However, when driving in the D range, the transmission will not up-shift from first gear, regardless of the vehicle speed.

Diagnostic Code 41 (Throttle position sensor circuitry) (1FZ-FE engine)

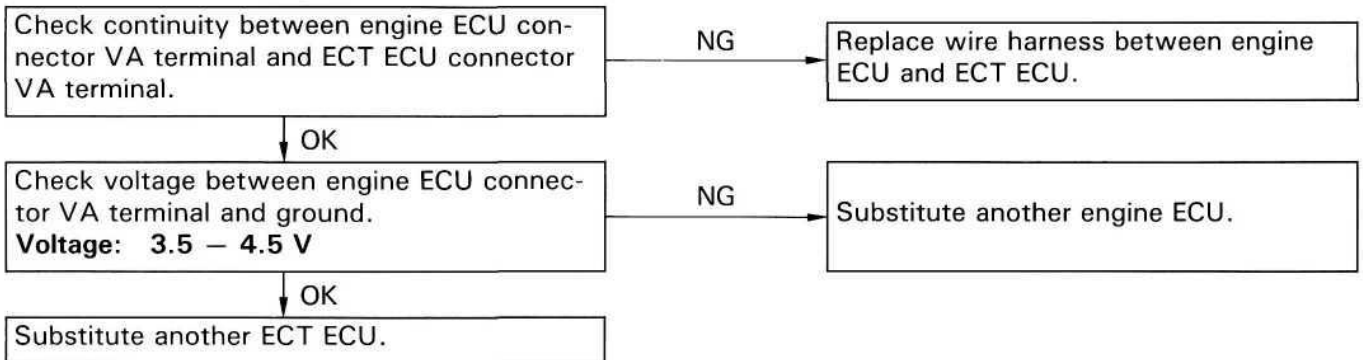

Diagnostic trouble Code 41 (Throttle position sensor circuitry) (1HD-T engine)

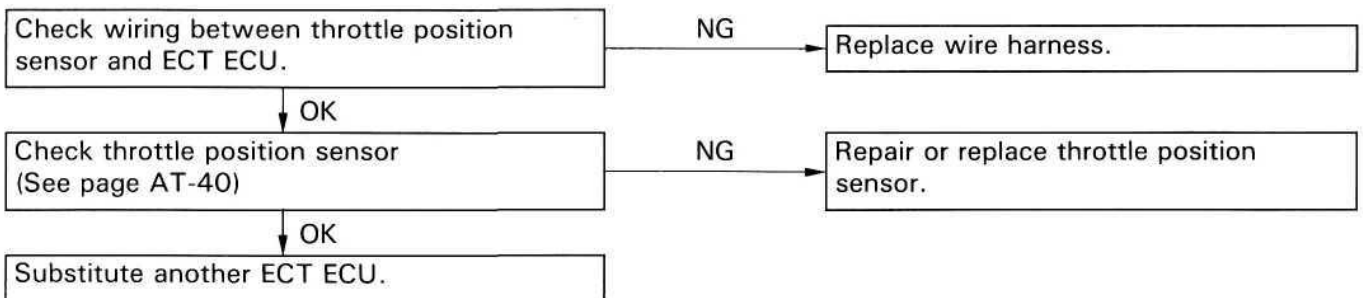

Diagnostic Code 42 (No. 1 speed sensor circuitry)

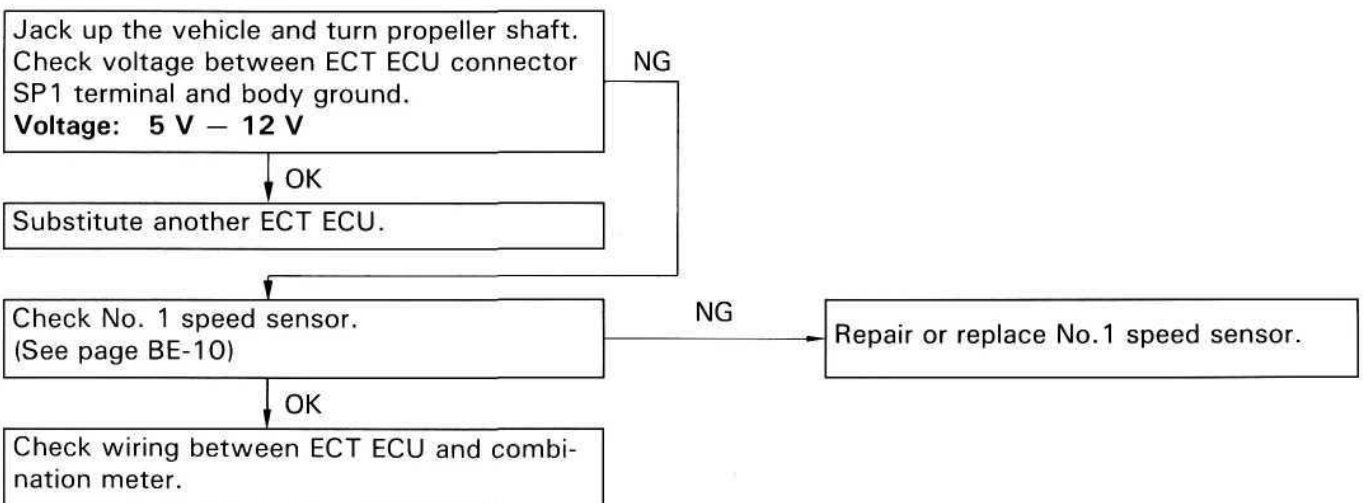

Diagnostic Code 61 (No.2 speed sensor circuitry)

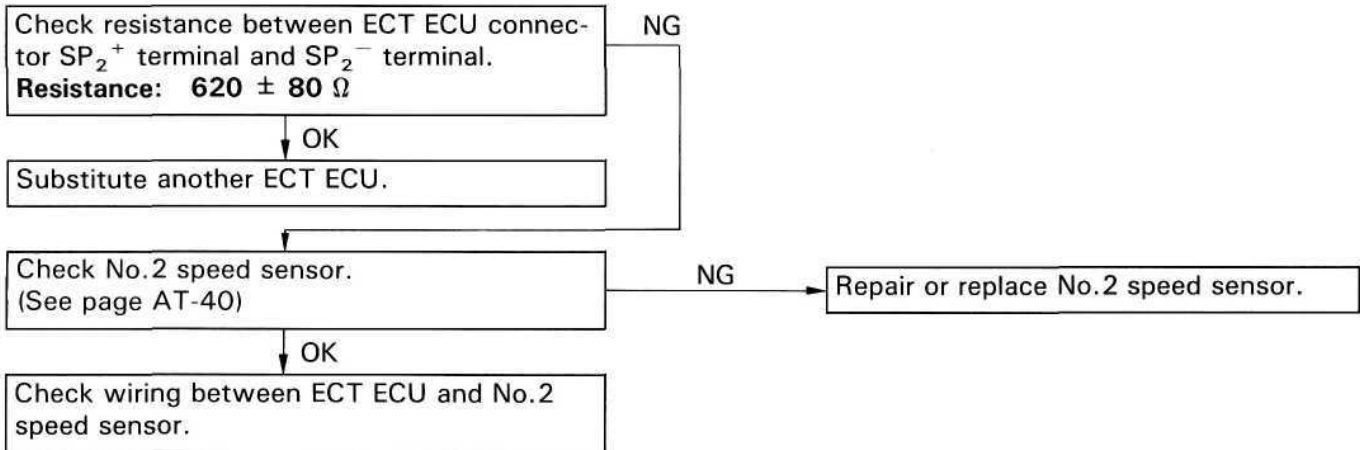

Diagnostic Code 62 (No.1 solenoid valve circuitry)

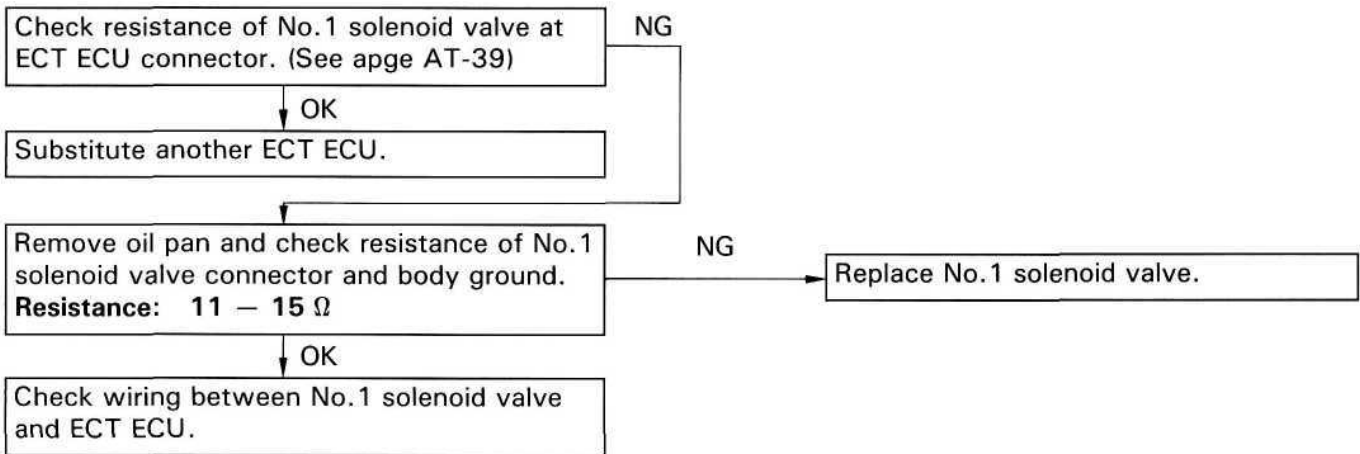

Diagnostic Code 63 (No. 2 solenoid valve circuitry)

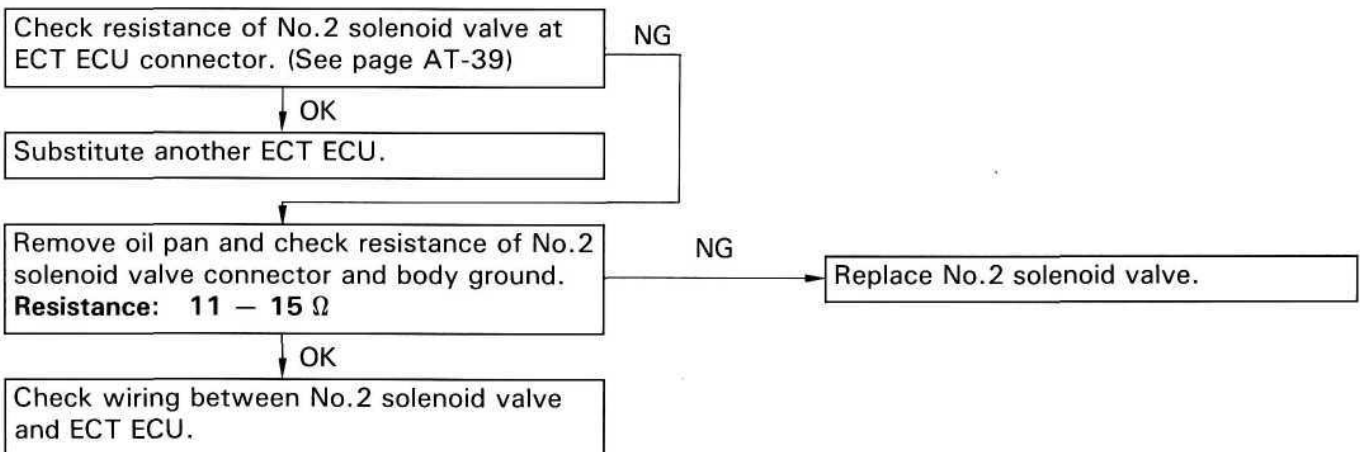

Diagnostic Code 64 (Lock-up solenoid valve circuitry)

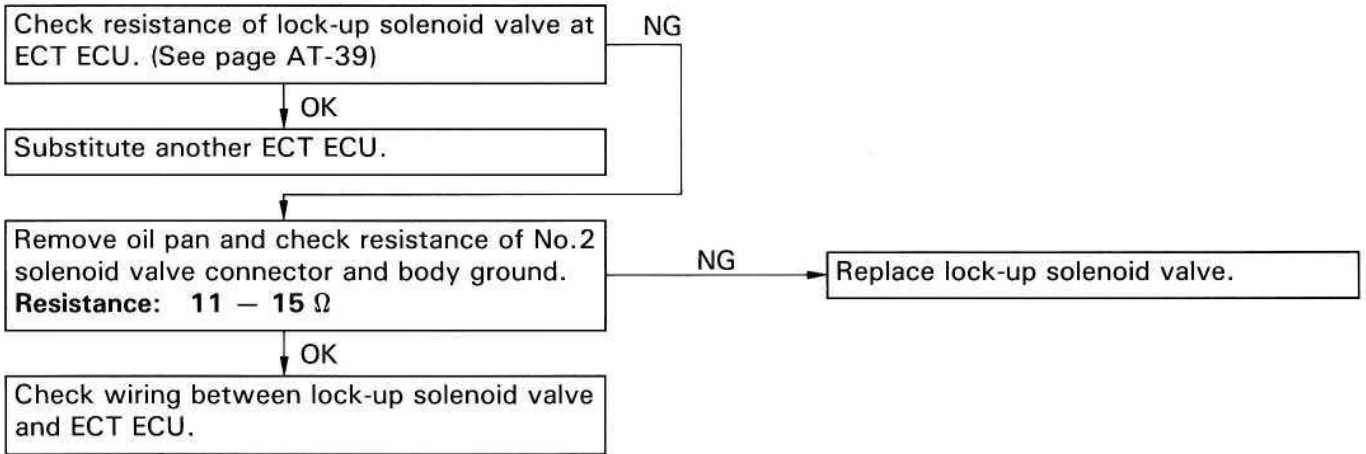

Diagnostic Code 65 (Timing solenoid valve circuitry)

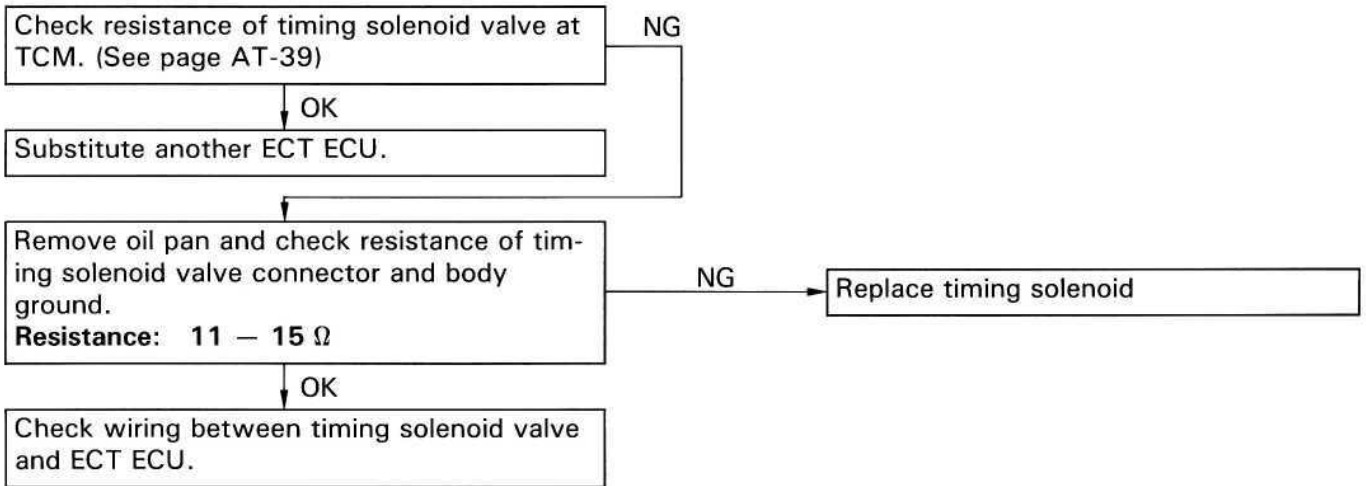

Diagnostic Code 86 (Engine speed sensor circuitry) (1FZ-FE engine)

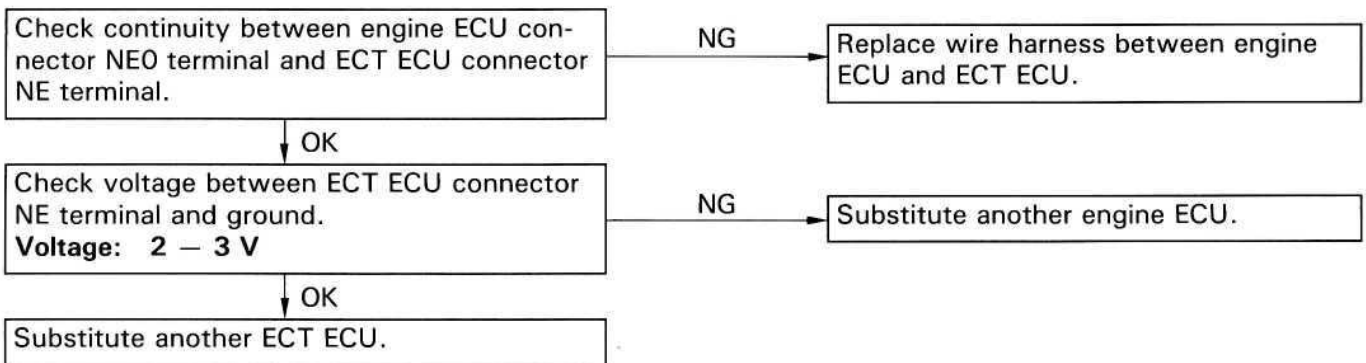

Diagnostic Code 86 (Engine speed sensor circuitry) (1HD-T engine)

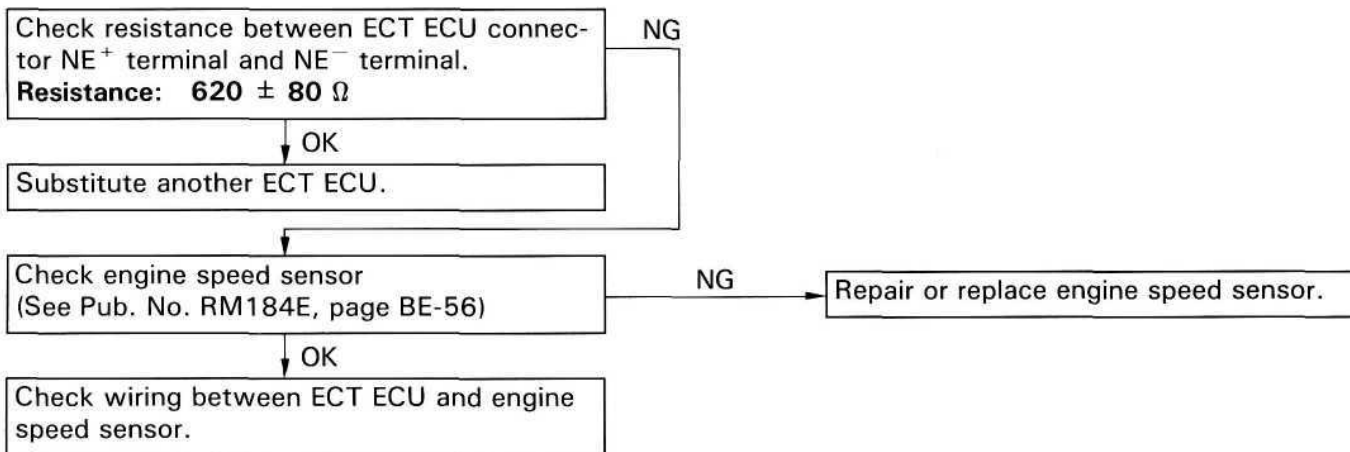

(1FZ-FE engine only)

Diagnostic Code 88 (Timing retard demand signal and fail safe signal circuitry)

(Timing retard demand signal)

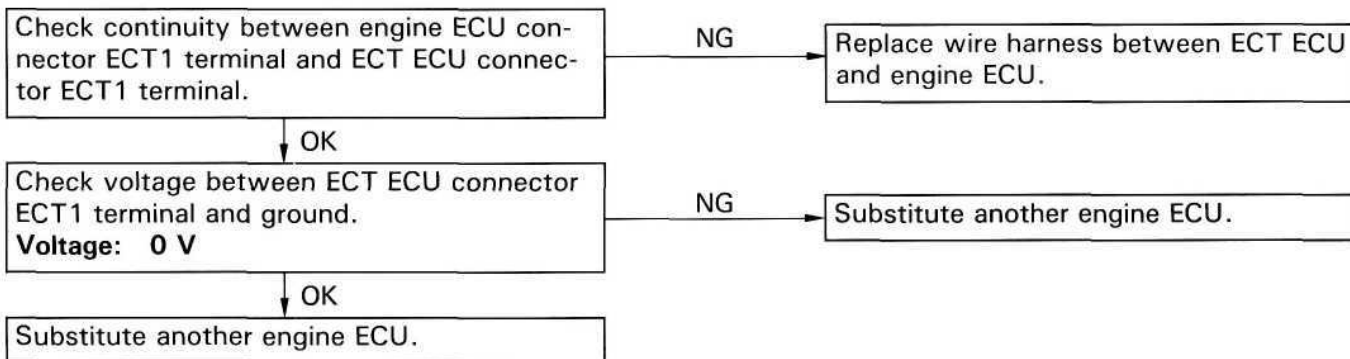

(Fail safe signal)

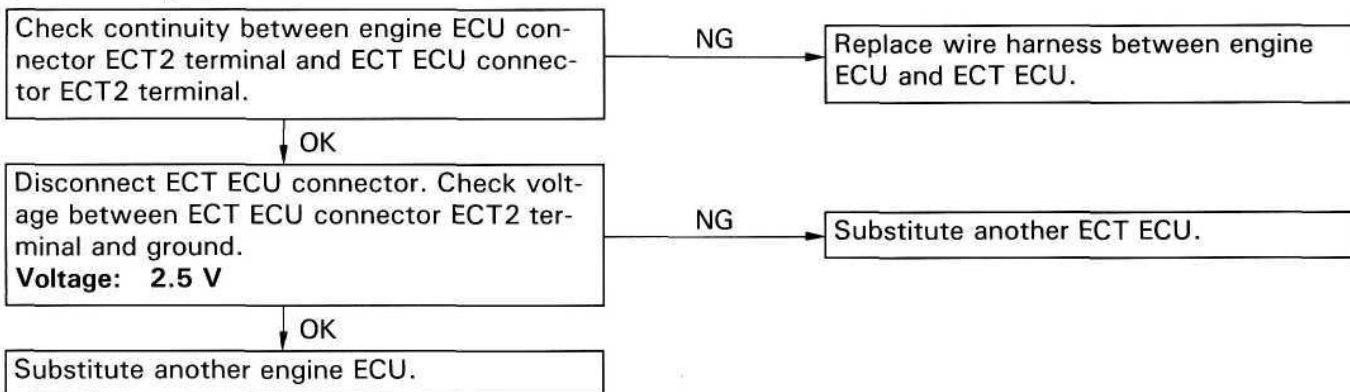

PRELIMINARY CHECK

1. CHECK FLUID LEVEL

HINT:

- The vehicle must have driven so that the engine and transmission are at normal operating temperature.

(Fluid temperature: 70 - 80°C or 158 - 176°F)

- Only use the COOL range on the dipstick as a rough reference when the fluid is replaced or the engine does not run.

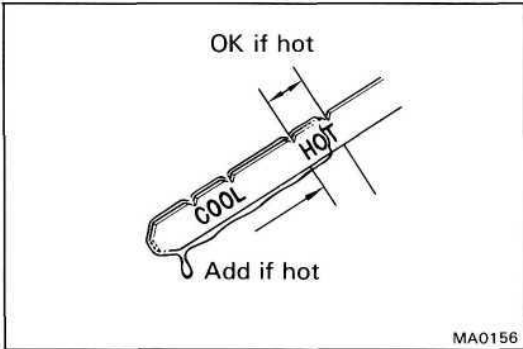

- Park the vehicle on a level surface, set the parking brake.
- With the engine idling, shift the shift lever into all positions from P to L range and return to P range.
- Pull out the transmission dipstick and wipe it clean.
- Push it back fully into the tube.
- Pull it out and check that the fluid level is on the HOT range.

If the level is at the low side, add fluid.

Fluid type:

ATF DEXRON® II

NOTICE: Do not overfill.

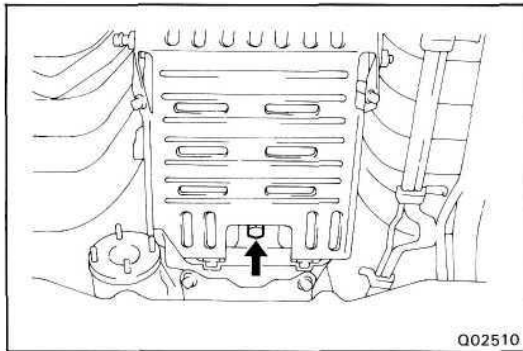

2. CHECK FLUID CONDITION

If the fluid smells burnt or is black, replace it in the following procedure.

- Remove the drain plug and drain the fluid.
- Reinstall the drain plug securely.

Torque: 27 N-m (280 kgf-cm, 20 ft-lbf)

- With the engine OFF, add new fluid through the oil filler tube.

Fluid type:

ATF DEXRON® II

Capacity:

Total

(w/o Oil cooler)

15.4 liters (16.3 US qts, 13.6 Imp.qts)

(w/o Oil cooler)

15.0 liters (15.9 US qts, 13.2 Imp.qts)

Drain and refill

6.0 liters (6.3 US qts, 5.3 Imp.qts)

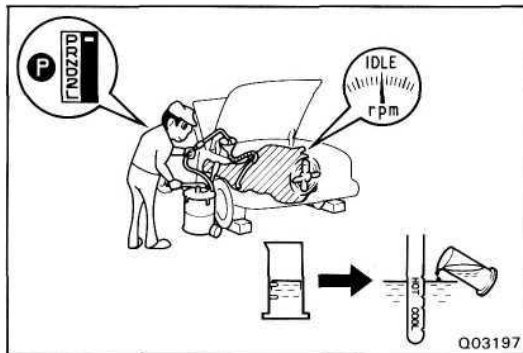

- Start the engine and shift the shift lever into all positions from P to L range and then shift into P range.
- With the engine idling, check the fluid level. Add fluid up to the COOL level on the dipstick.

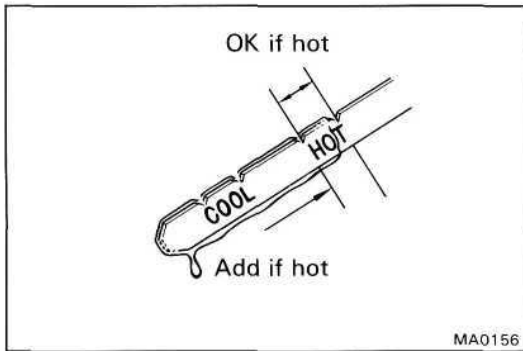

- (f) Check the fluid level with the normal operating temperature (70 — 80°C or 158 — 176°F) and add as necessary.

NOTICE: Do not overfill.

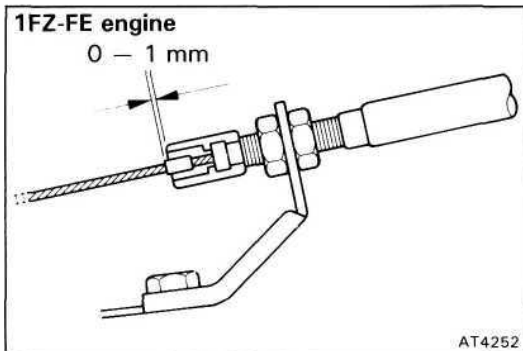

3. INSPECT THROTTLE CABLE

- (a) Check that the throttle cable is installed correctly and not bent.
- (b) With the throttle valve fully closed, measure the distance between the end of the boot and stopper on the cable.

Standard distance:

(1FZ-FE engine) 0 — 1 mm (0 — 0.04 in.)

(1HD-T engine) 0.5 - 1.5 mm (0.020 - 0.059 in.)

If the distance is not standard, adjust the cable by the adjusting nuts.

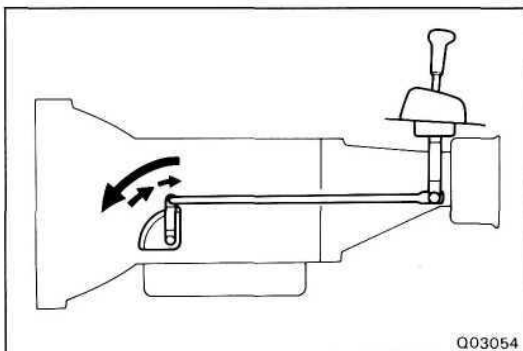
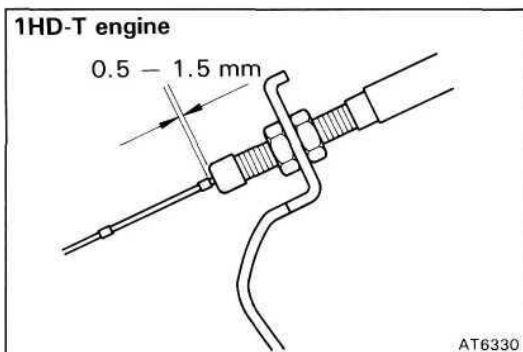

4. INSPECT TRANSMISSION SHIFT LEVER RANGE

When shifting the shift lever from the N range to other ranges, check that the lever can be shifted smoothly and accurately to each range and that the position indicator correctly indicates the position.

If the indicator is not aligned with the correct position, carry out the following adjustment procedures.

- (a) Loosen the nut on the control rod.
- (b) Push the control shaft lever fully toward the rear of the vehicle.
- (c) Return the control shaft lever two notches to N range.
- (d) Set the shift lever to N range.
- (e) While holding the shift lever lightly toward the R range side, tighten the control rod nut.
- (f) Start the engine and make sure that the vehicle moves forward when shifting the lever from the N to D range and reverse when shifting it to the R range.

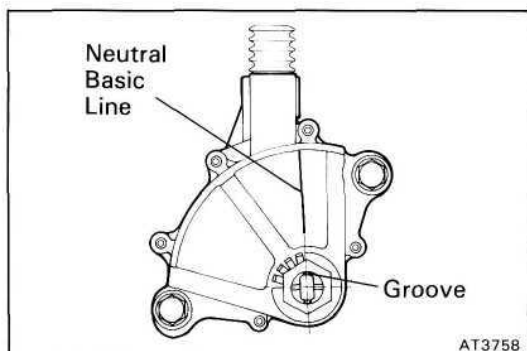

5. INSPECT NEUTRAL START SWITCH

Check that the engine can be started with the shift lever only in the N or P range, but not in other ranges.

If not as started above, carry out the following adjustment procedures.

- Loosen the neutral start switch bolts and set the shift lever to the N range.
- Align the groove and neutral basic line.
- Hold in position and tighten the bolts.

Torque: 13 Nm (130 kgfcm, 9 ftlbf)

6. INSPECT IDLE SPEED (N RANGE)

Connect tachometer test probe to the check connector terminal IG \ominus , inspect the idle speed.

Idle speed:

650 rpm

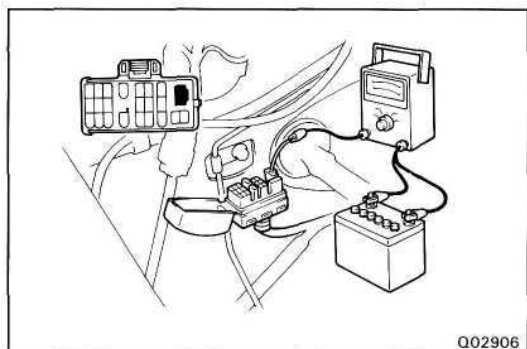

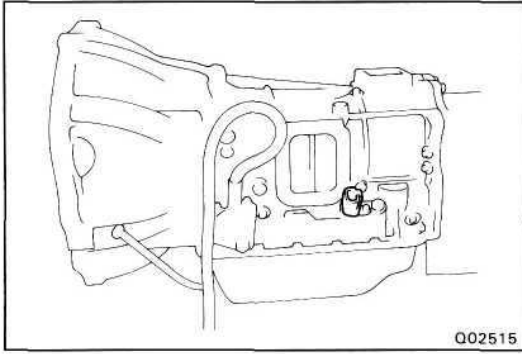

MANUAL SHIFTING TEST

HINT: With this test, it can be determine whether the trouble lies within the electrical circuit or is a mechanical problem in the transmission.

1. DISCONNECT SOLENOID WIRE
2. INSPECT MANUAL DRIVING OPERATION

Check that the shift and gear position correspond with the table below.

HINT: If the L, 2 and D range gear position are difficult to distinguish, perform the following road test.

- While driving, shift through the L, 2 and D ranges. Check that the gear change corresponds to the shift position.
- If any abnormality is found in the above test, the problem lies in transmission itself.

3. CONNECT SOLENOID WIRE
4. CANCEL OUT DIAGNOSTIC CODE
(See page AT-20)

REFERANCE: Possible gear position in accordance with solenoid operating conditions.

Range	NORMAL			NO.1 SOLENOID MALFUNCTIONING			NO.2 SOLENOID MALFUNCTIONING			BOTH SOLENOIDS MALFUNCTIONING		
	Solenoid Valve		Gear Position	Solenoid Valve		Gear Position	Solenoid Valve		Gear Position	Solenoid Valve		Gear Position
	No.1	No.2		No.1	No.2		No.1	No.2		No.1	No.2	
D range	ON	OFF	1st	x	ON (OFF)	3rd (O/D)	ON	x	1st	x	x	O/D
	ON	ON	2nd	x	ON	3rd	OFF (ON)	x	O/D (1st)	x	x	O/D
	OFF	ON	3rd	x	ON	3rd	OFF	x	O/D	x	x	O/D
	OFF	OFF	O/D	x	OFF	O/D	OFF	x	O/D	x	x	O/D
2 range	ON	OFF	1st	x	ON (OFF)	3rd (O/D)	ON	x	1st	x	x	3rd
	ON	ON	2nd	x	ON	3rd	OFF (ON)	x	3rd (1st)	x	x	3rd
	OFF	ON	3rd	x	ON	3rd	OFF	x	3rd	x	x	3rd
L range	ON	OFF	1st	x	OFF	1st	ON	x	1st	x	x	1st
	ON	ON	2nd	x	ON	2nd	ON	x	1st	x	x	1st

(): No fail-safe function x: Malfunctions

ELECTRONIC CONTROL SYSTEM

PRECAUTION

Do not open the cover or the case of the TCM and various computer unless absolutely necessary. (If the IC terminals are touched, the IC may be destroyed by static electricity.)

ELECTRONIC CONTROL CIRCUIT

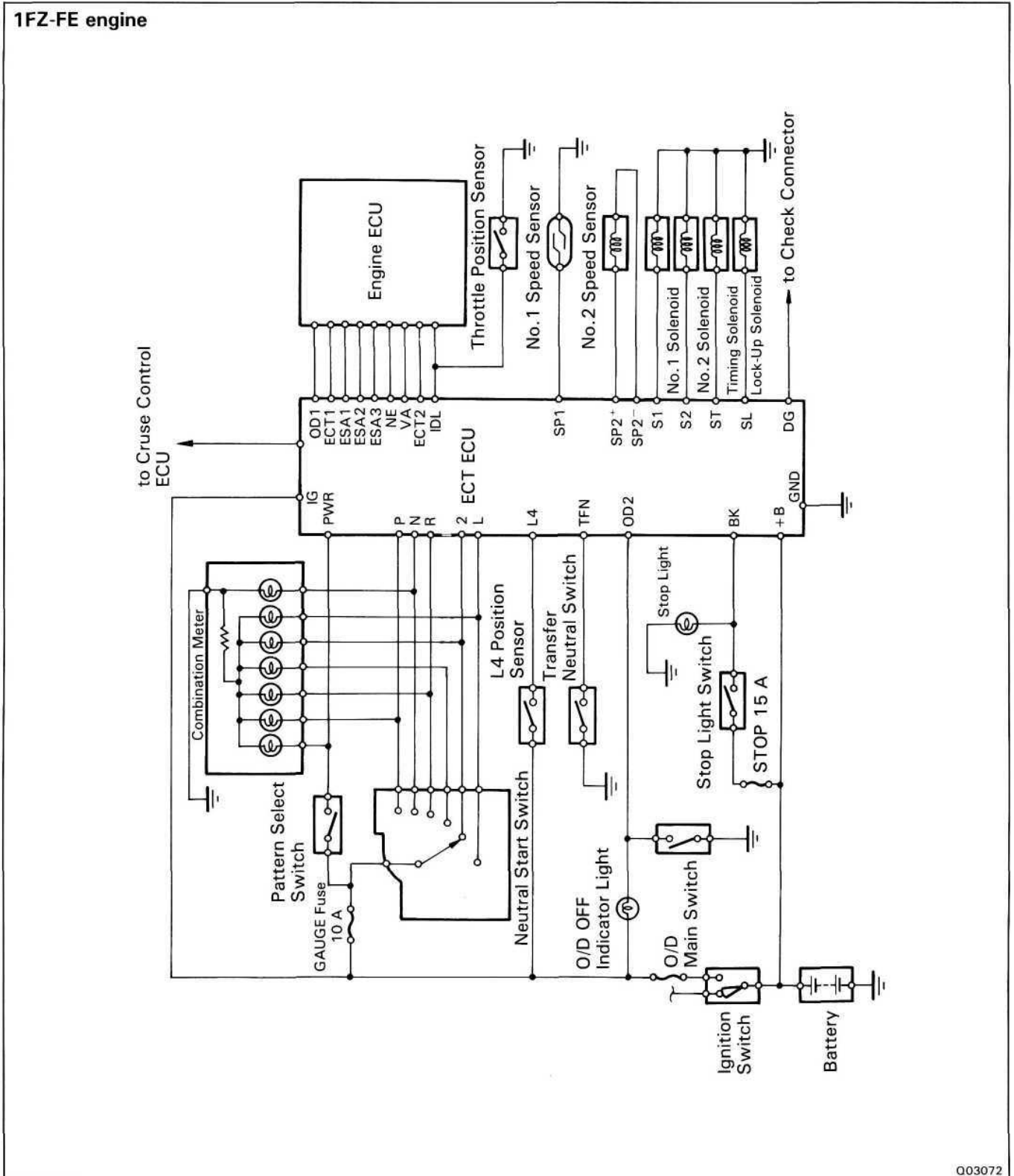

1HD-T engine

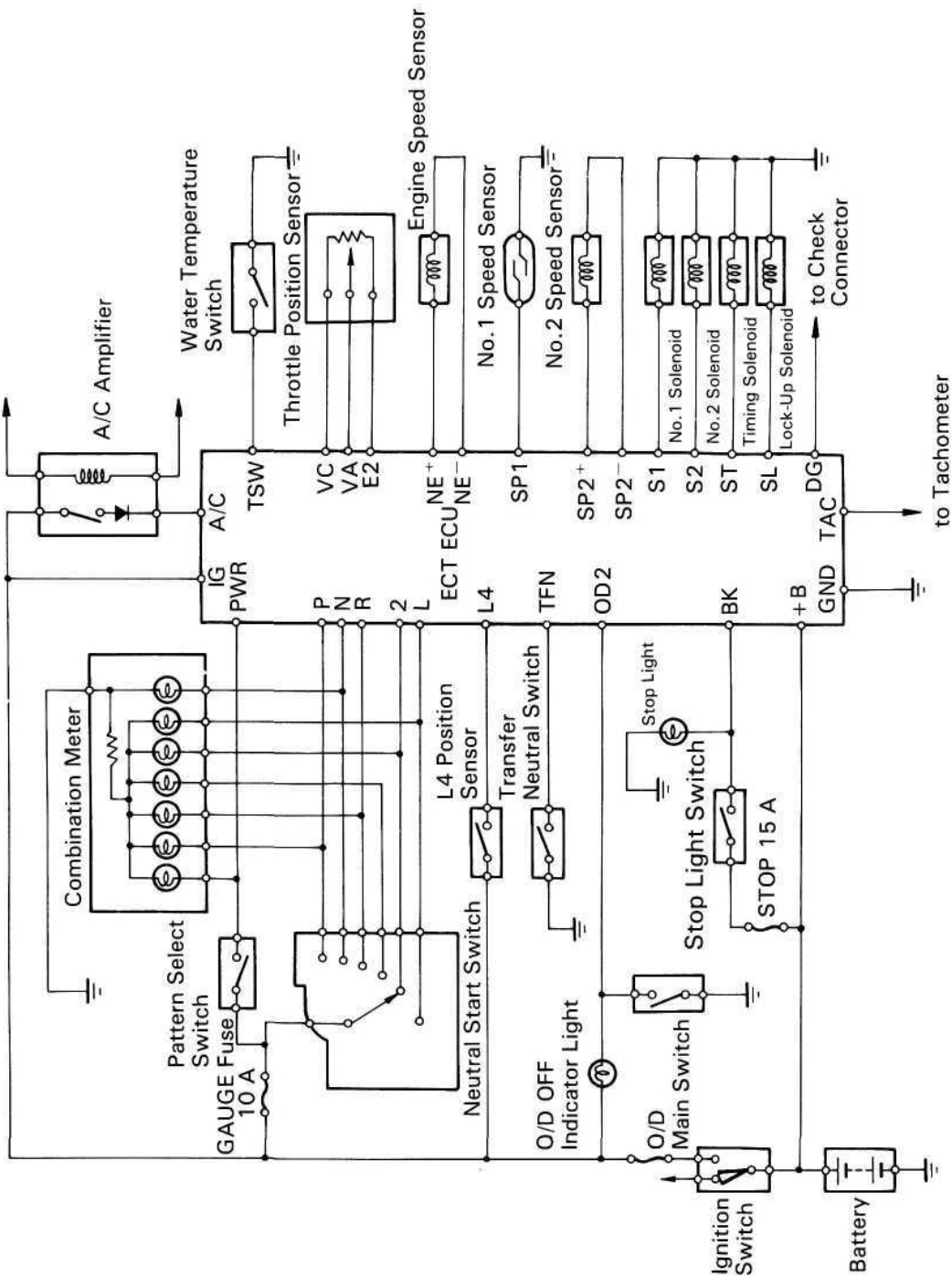

ELECTRONIC CONTROL COMPONENTS

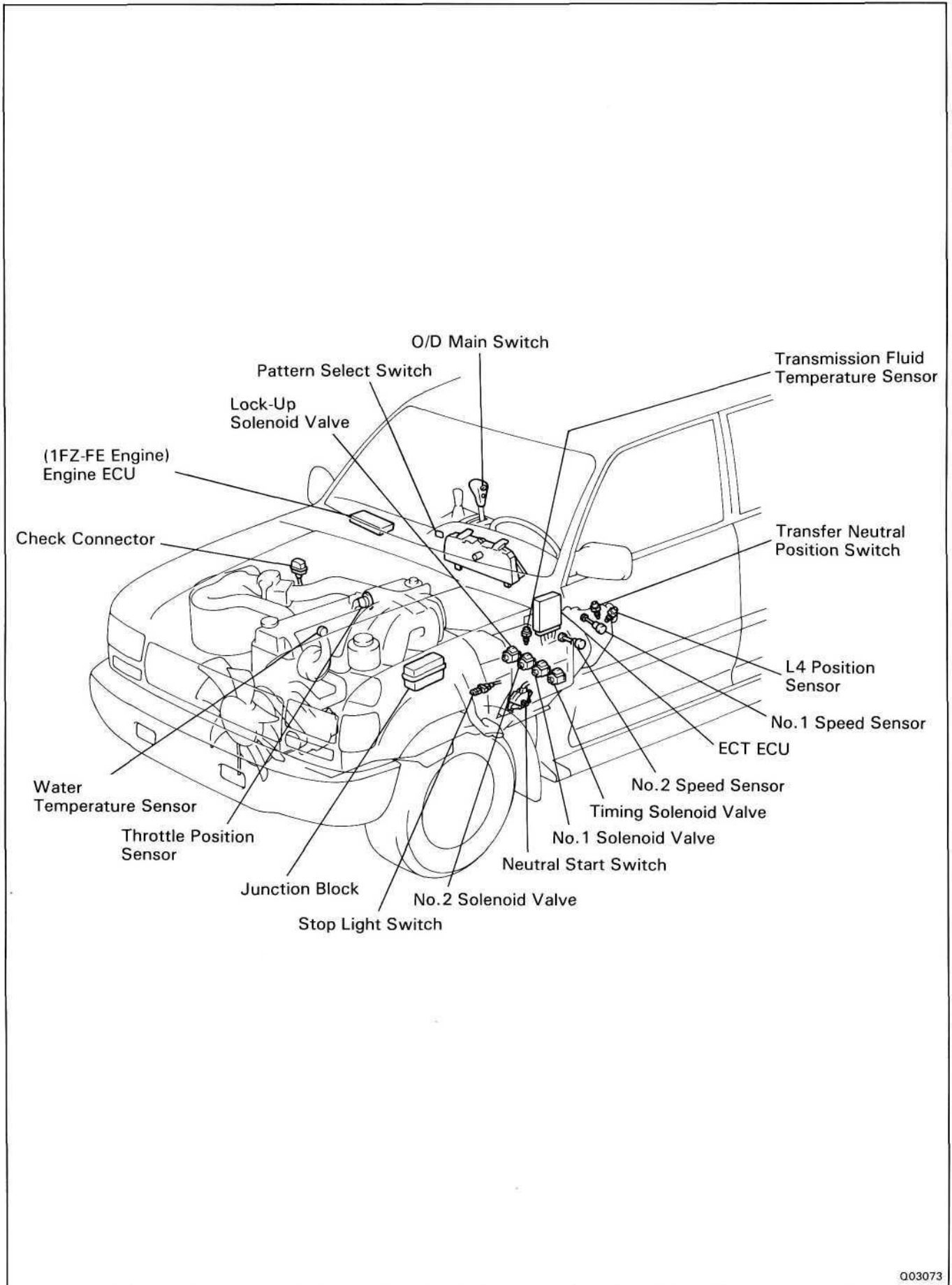

TROUBLESHOOTING FLOW - CHART

Trouble No. 1 No Shifting

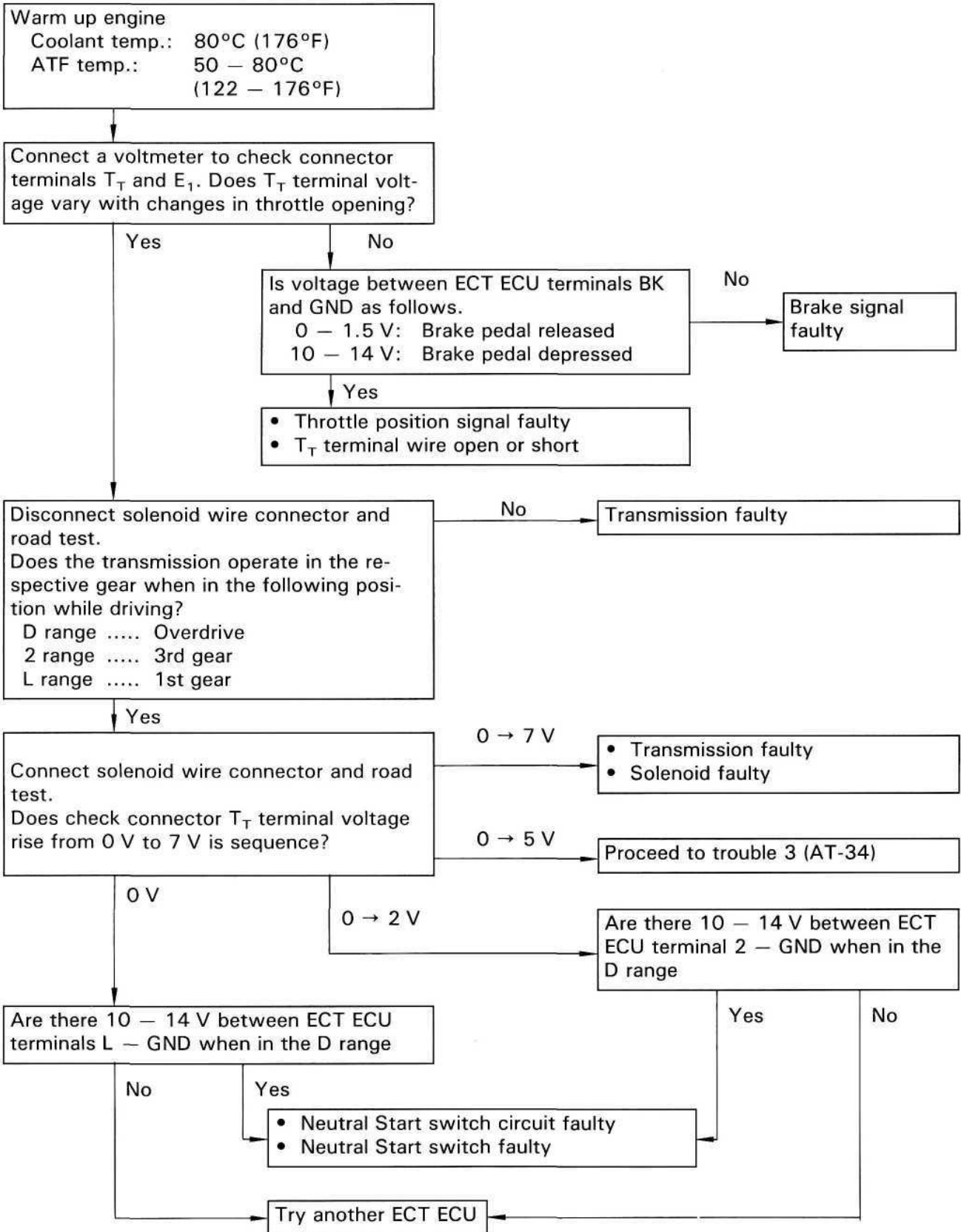

Trouble No.2 Shift point too high or too low

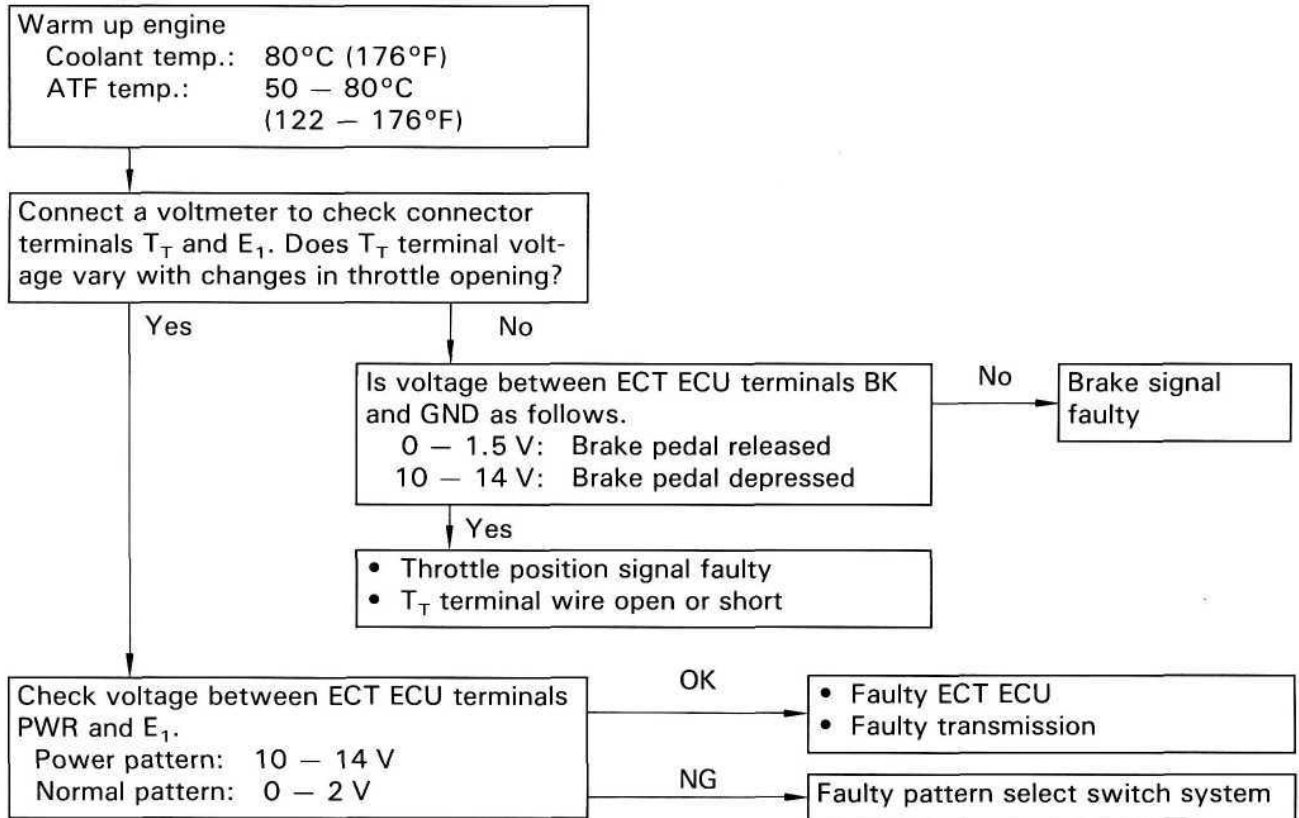

Trouble No.3 No up-shift to overdrive (After warm-up)

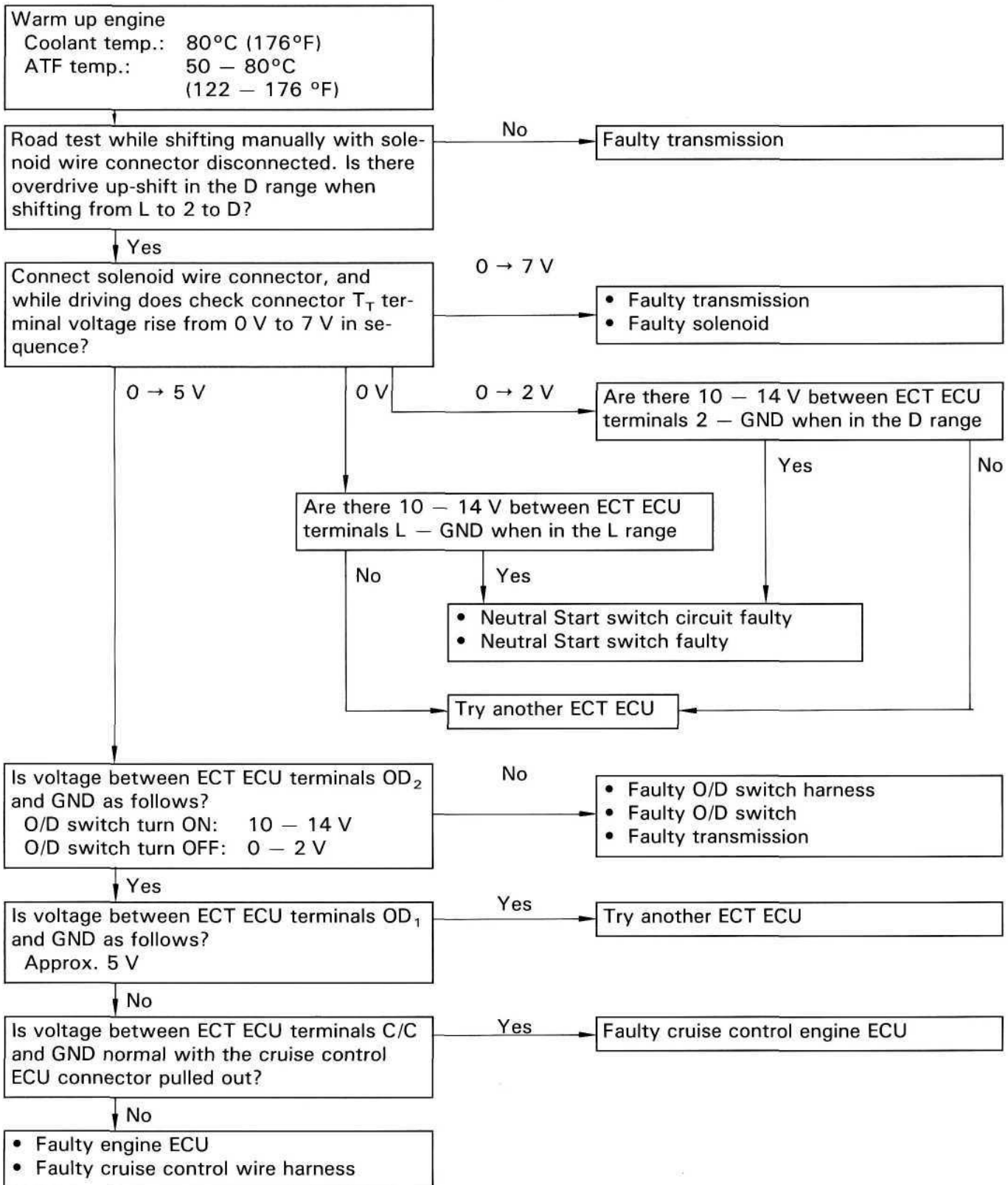

Trouble No.4 No lock-up (After warm-up)

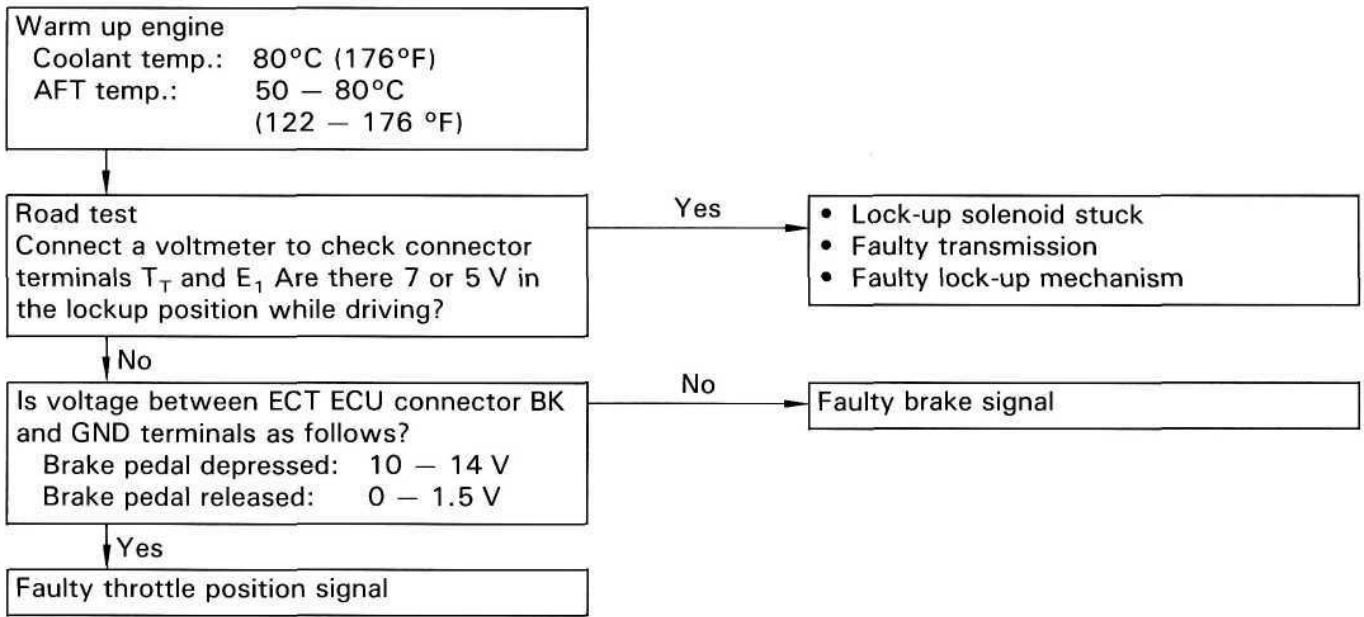

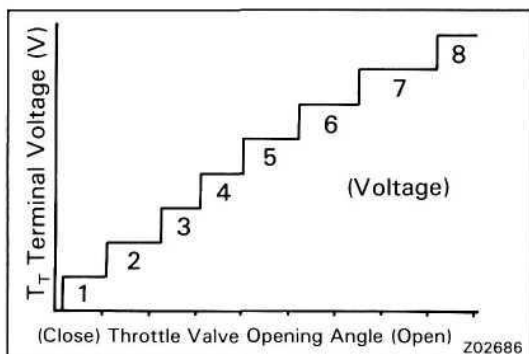
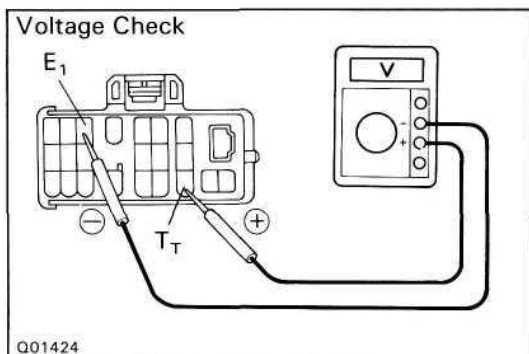

T_T TERMINAL VOLTAGE INSPECTION

1. INSPECT THROTTLE POSITION SENSOR SIGNAL

- (a) Turn the ignition switch to ON. Do not start the engine.
- (b) Connect a voltmeter to check connector terminals T_T and

- (c) While slowly depressing the accelerator pedal, check that T_T terminal voltage rises in sequence.

If the voltage does not change in proportion to the throttle opening angle, there is a malfunction in the throttle position sensor or circuit.

2. INSPECT BRAKE SIGNAL

- (a) Depress the accelerator pedal until the T_T terminal indicates 8 V.
- (b) Depress the brake pedal and check the voltage reading from the T_T terminal.

Brake pedal depressed. 0 V

Brake pedal released. 8 V

If not as indicated, there is a malfunction in either the stop light switch or circuit.

3. INSPECT EACH UPSHIFT POSITION

- (a) Warm up the engine.
Coolant temperature:
80°C (176 °F)
- (b) Turn the O/D switch to "ON".
- (c) Place the pattern select switch in "Normal" and the shift lever into the D range.
- (d) During a road test (about 10 km/h or 6 mph) check that voltage at the T_T terminal is as indicated below for each up—shift position.

If the voltage rises from 0 V to 7 V in the sequence shown, the control system is okay.

The chart on the left shows the voltmeter reading and corresponding gears.

HINT: Determine the gear position by a light shock or change in engine rpm when shifting. The lock-up clutch will turn ON only infrequently during normal 2nd and 3rd gear operation. To trigger this action, press the accelerator pedal to 50% or more of its stroke. At more than 50%, the voltage may change in the sequence 2 V — 4 V - 6 V - 7 V.

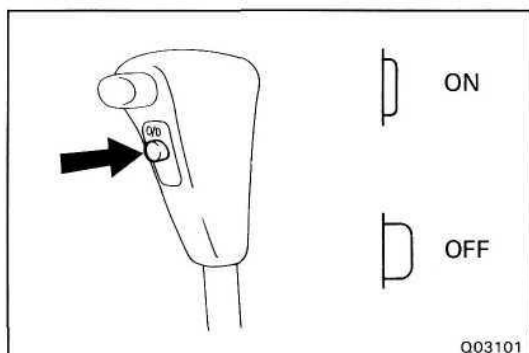

T _T Terminal (V)	Gear Position
0	1st
2	2nd
4	3rd
5	3rd Lock-up
6	O/D
7	O/D Lock-up

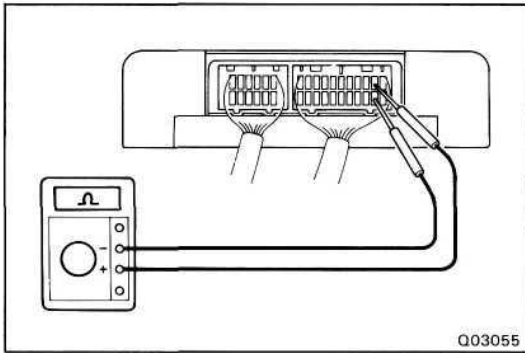

ELECTRONIC CONTROL COMPONENTS INSPECTION

1. INSPECT VOLTAGE OF ECT ECU

- (a) Turn on the ignition switch.
- (b) Measure the voltage at each terminal.

(1FZ-FE Engine)

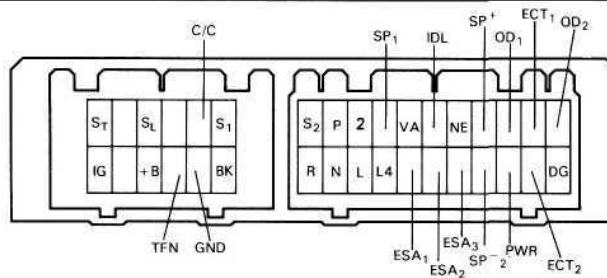

003115

Terminal	Measuring condition		Voltage (V)
S1 – GND	Stop Vehicle	N range	9 – 14
		D range	9 – 14
S2 – GND	Stop vehicle		0 – 1.5
SL – GND	Stop vehicle		0 – 1.5
ST – GND	Stop vehicle		0 – 1.5
BK – GND	Brake pedal is depressed		7.5 – 14
	Brake pedal is released		0 – 1.5
TFN – GND	Transfer position is N range		0 – 3
	Transfer position is except N range		9 – 14
+B – GND	Stop engine and ignition switch ON		9 – 14
IG – GND	Stop engine and ignition switch ON		9 – 14
OD ₂ – GND	O/D main switch turned ON		9 – 14
	O/D main switch turned OFF		0 – 3
C/C – GND	Stop engine and ignition switch ON		9 – 14
ECT1 – GND	Stop engine and ignition switch ON		9 – 14
OD1 – GND	Water temperature 55°C (131°F) more than		9 – 14
	Water temperature 55°C (131°F) or less		0 – 3
SP2 ⁺ – SP2 ⁻	Vehicle moving		Pulse generation
SP1 – GND	Vehicle moving		Pulse generation
NE – GND	Engine idling speed		Pulse generation
IDL – GND	Throttle valve fully closed		0 – 3
	Throttle valve fully open		9 – 14
VA – GND	Throttle valve fully closed		3.5 – 4.5
	Throttle valve fully open		2.5 – 3.5

Terminal	Measuring condition	Voltage (V)
2 – GND	2 range	7.5 – 14
	Except 2 range	0 – 1.5
P – GND	P range	7.5 – 14
	Except P range	0 – 1.5
L – GND	L range	7.5 – 14
	Except L range	0 – 1.5
N – GND	N range	7.5 – 14
	Except N range	0 – 1.5
R – GND	R range	7.5 – 14
	Except R range	0 – 1.5
DG – GND	Engine stop and place ignition key at ON position	0 – 1.5
ECT2 – GND	Engine coolant temperature 80°C (176°F) more than	2 – 3
PWR – GND	PWR pattern	7.5 – 14
	NORM pattern	0 – 1.5
ESA1 – GND	Engine idling speed (Engine start after 10 second)	4.5 – 5.5
ESA2 – GND	Engine idling speed (Engine start after 10 second)	4.5 – 5.5
ESA3 – GND	Engine idling speed (Engine start after 10 second)	4.5 – 5.5
L4 – GND	Transfer position is L4 position	7.5 – 14
	Transfer position is except L4 position	0 – 15

(1HD-T Engine)

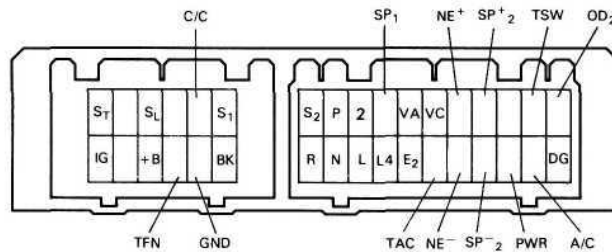

Q03115

Terminal	Measuring condition	Voltage (V)	
S1 – GND	Stop Vehicle	N range	9 – 14
		D range	9 – 14
S2 – GND	Stop vehicle	0 – 1.5	
SL – GND	Stop vehicle	0 – 1.5	
ST – GND	Stop vehicle	0 – 1.5	
BK – GND	Brake pedal is depressed	7.5 – 14	
	Brake pedal is released	0 – 1.5	
TFN – GND	Transfer position is N range	0 – 3	
	Transfer position is except N range	9 – 14	
+B – GND	Stop engine and ignition switch ON	9 – 14	
IG – GND	Stop engine and ignition switch ON	9 – 14	
OD ₂ – GND	O/D main switch turned ON	9 – 14	
	O/D main switch turned OFF	0 – 3	

Terminal	Measuring condition	Voltage (V)
2 – GND	2 range	7.5 – 14
	Except 2 range	0 – 1.5
P – GND	P range	7.5 – 14
	Except P range	0 – 1.5
L – GND	L range	7.5 – 14
	Except L range	0 – 1.5
N – GND	N range	7.5 – 14
	Except N range	0 – 1.5
R – GND	R range	7.5 – 14
	Except R range	0 – 1.5
DG – GND	Engine stop and place ignition key at ON position	0 – 1.5
VC – GND	Ignition switch ON	4.5 – 5.5
TAC – GND	Engine idling speed	Pulse generation
TSW – GND	Water temperature 55°C (131°F) more than	9 – 14
	Water temperature 43°C (109°F) or less	0 – 3
SP2 ⁺ – SP2 ⁻	Vehicle moving	Pulse generation
SP1 – GND	Vehicle moving	Pulse generation
NE ⁺ – NE ⁻	Engine idling speed	Pulse generation
A/C – GND	A/C control switch ON (Engine idling speed)	7.5 – 14
	A/C control switch OFF	0 – 1.5
VA – GND	Throttle valve fully closed (Warm up engine and A/C control switch OFF)	2.8 – 33
	Throttle valve fully open (Warm up engine and A/C control switch OFF)	0.3 – 0.8
PWR – GND	PWR pattern	7.5 – 14
	NORM pattern	0 – 1.5
L4 – GND	Transfer position is L4 range	7.5 – 14
	Transfer position is except L4 range	0 – 15

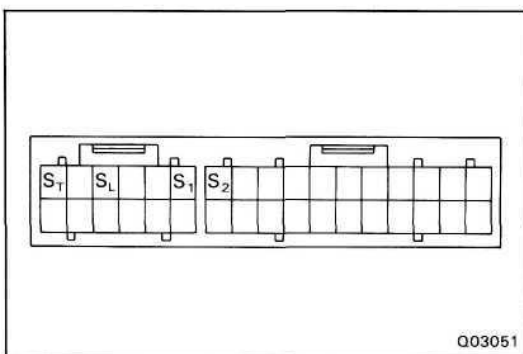

2. INSPECT SOLENOID

- (a) Disconnect the connector from ECT ECU.
- (b) Measure the resistance between S₁, S₂, S_L, S_T and ground.

Resistance:

11-15 Ω

- (c) Apply battery voltage to each terminal. Check that an operation noise can be heard from the solenoid.

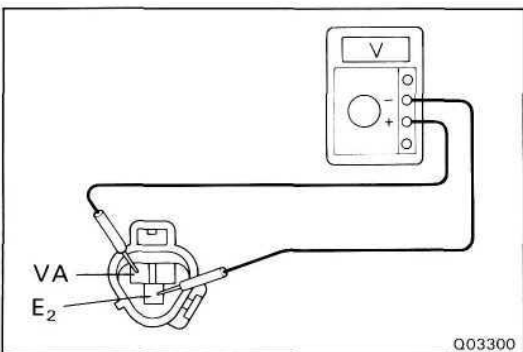
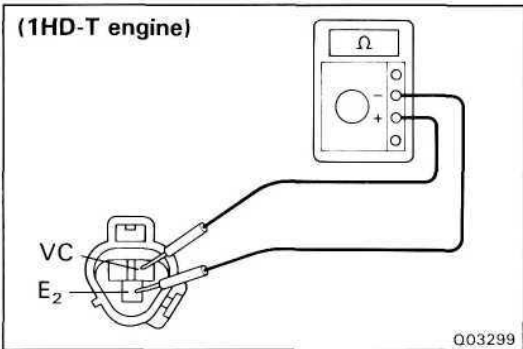
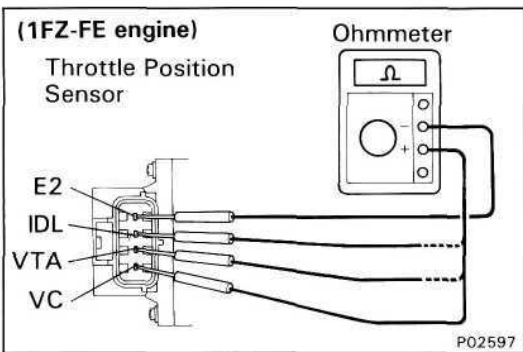
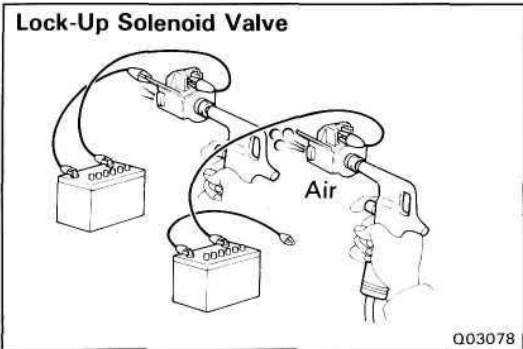
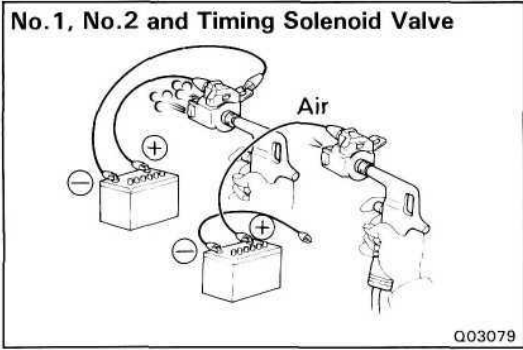

3. CHECK SOLENOID SEALS

If there is foreign material in the solenoid valve, there will be no fluid control even with solenoid operation.

- (a) Check No.1, No.2 and timing solenoid valves.
 - Check that the solenoid valves do not leak when low-pressure compressed air is applied.
 - When supply battery voltage to the solenoids, check that the solenoid valves open.

- (b) Check the lock-up solenoid valve.
 - Apply 490 kPa (5 kgf/cm², 71 psi) of compressed air, check that the solenoid valve opens.
 - When supply battery voltage to the solenoid, check that the solenoid valve does not leak the air.

If malfunction is found during voltage inspection (step 1.), inspect the components listed below.

4. INSPECT THROTTLE POSITION SENSOR

- (a) Using an ohmmeter, check the resistance between terminals.

(1FZ-FE)

Terminal	Throttle valve condition	Resistance (kΩ)
IDL - E ₂	Fully closed	2.3 kΩ or less
	Open	Infinity
VC - E ₂	—	2.5 - 5.9
VTA - E ₂	Fully closed	0.2 - 5.7
	Fully open	2.0 - 10.2

(1HD-T)

Terminal	Throttle valve condition	Resistance (kΩ)
VC - E ₂	Fully open	1.84 - 3.42

- (b) (1HD-T engine)
When supply 5V to the between VC terminal and E₂ terminal, using a voltmeter, check the voltage between terminals.

Terminal	Throttle valve condition	Voltage (V)
VA - E ₂	Fully open	0.96

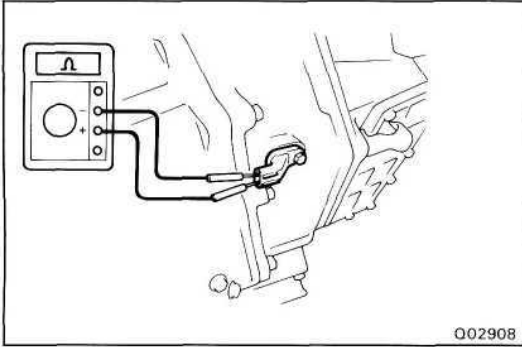

5. INSPECT NO.2 SPEED SENSOR

- (a) Jack up the rear wheel on one side.
- (b) Connect an ohmmeter between the terminals.
- (c) Spin the wheel and check that the meter needle deflects from 0 to $\infty \Omega$.

6. INSPECT NO.1 SPEED SENSOR

(See page BE-10)

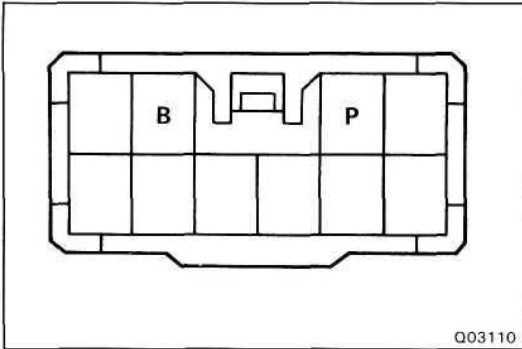

7. INSPECT PATTERN SELECT SWITCH

Using an ohmmeter, check the continuity of terminals for each switch position.

HINT: As there are diodes inside, be careful of the tester probe polarity.

Terminal	B	P
Pattern		
PWR	○—○	
NORM		

V02104

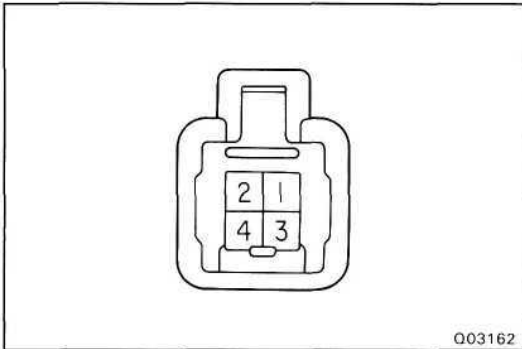

8. INSPECT O/D SWITCH

Using an ohmmeter, check the continuity of the terminals for each switch position.

Terminal	2	4
SW position		
ON		
OFF	○—○	

V02105

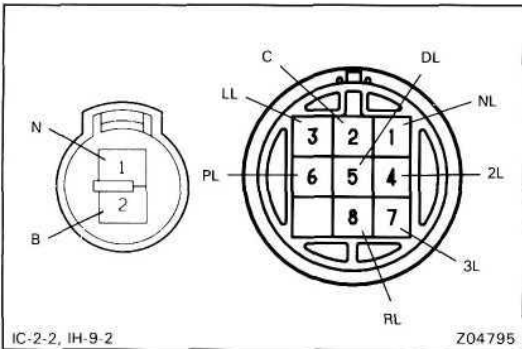

9. INSPECT NEUTRAL START SWITCH

Check that there is continuity between terminals.

○—○ : Continuity

Terminal Shift range	B	N	C	PL	RL	NL	DL	3I	2L
P	○—○		○—○						
R			○—○		○—○				
N	○—○		○—○			○—○			
D			○—○				○—○		
2			○—○					○—○	
L			○—○						○—○

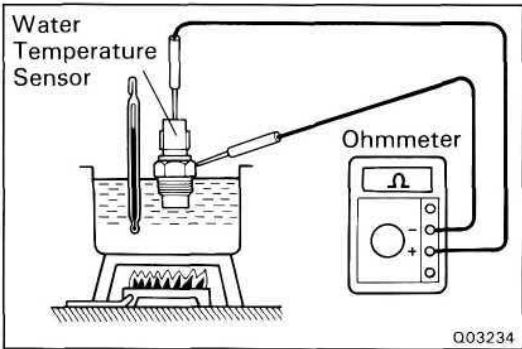

10. (1HD-T engine) INSPECT WATER TEMPERATURE SWITCH

Check that there is continuity at the temperature of 45°C - 55°C (113°F - 131°F).

If continuity is not as specified, replace the switch.

A/T FLUID TEMPERATURE WARNING SYSTEM CIRCUIT

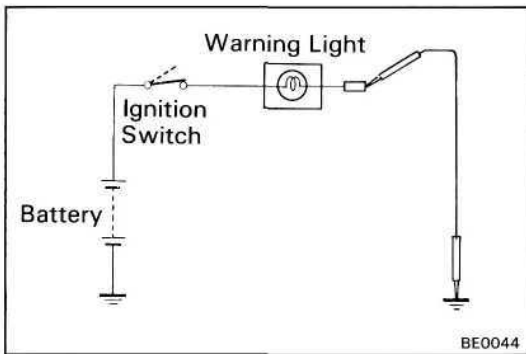
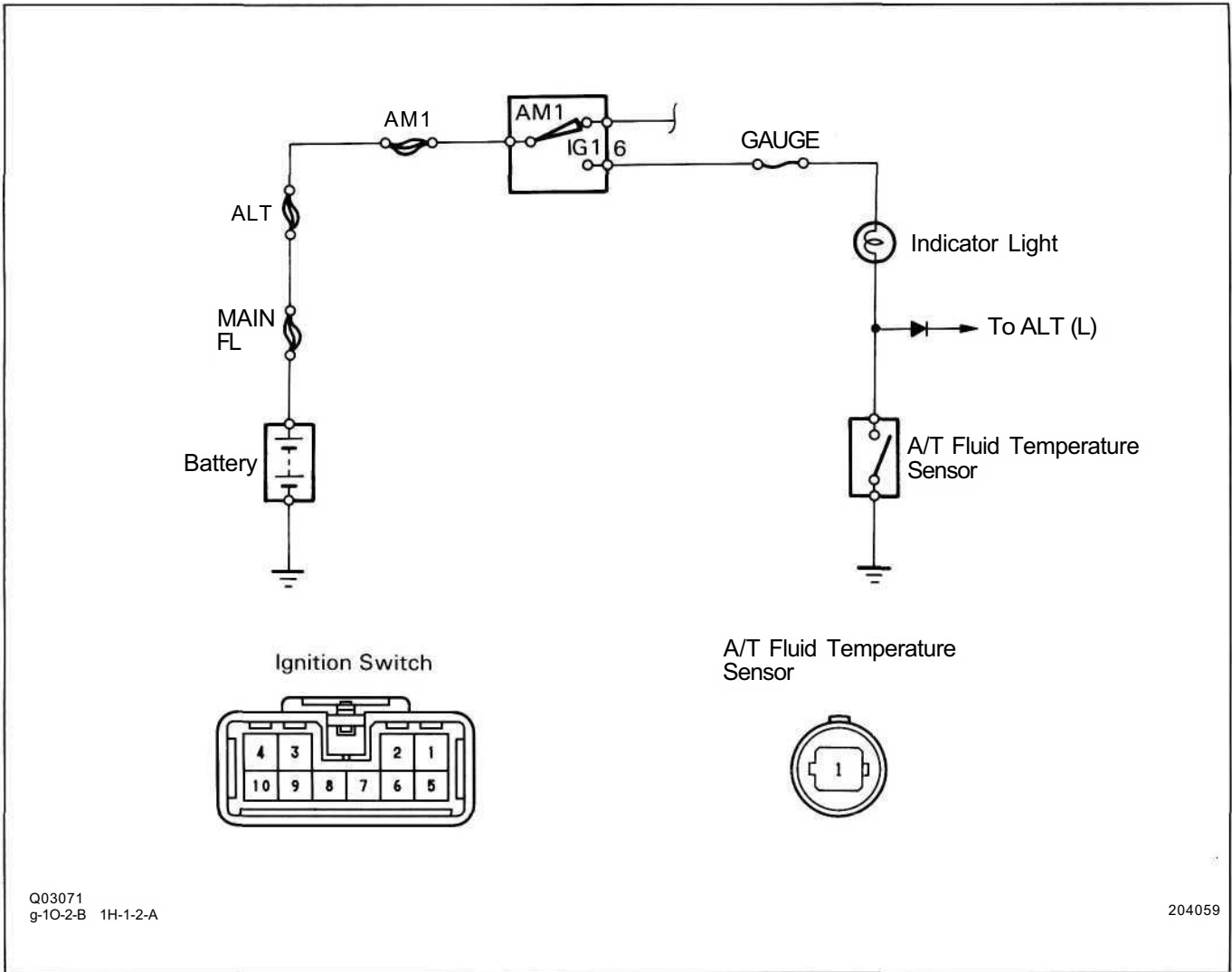

11. INSPECT A/T FLUID TEMPERATURE WARNING LIGHT

- (a) Disconnect the connector from the temperature sensor. Connect terminal of the wire harness side connector and body ground.
- (b) Turn the ignition switch ON, check that the light go on. If warning light does not light, test the bulb.

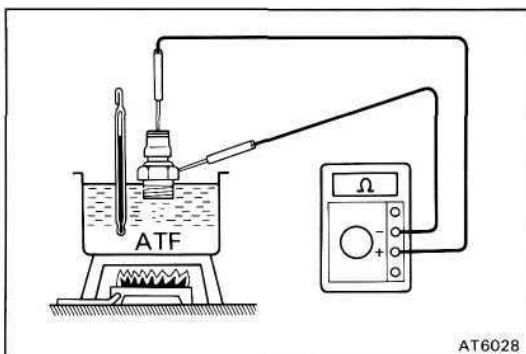

12. INSPECT A/T FLUID TEMPERATURE SENSOR

Check that there is continuity at the temperature of 145°C - 155°C (325°F - 343°F).

If continuity is not as specified, replace the sensor.

STALL TEST

The objective of this test is to check the overall performance of the transmission and engine by measuring the stall speeds in the D and R ranges.

NOTICE:

- Perform the test at normal operating fluid temperature (50 — 80°C, or 122 — 176°F).
- Do not continuously run this test longer than 5 seconds.
- To ensure safety, conduct this test in a wide, clear, level area, which provides good traction.
- The stall test should always be carried out in pairs. One should observe the conditions of wheels or wheel stoppers outside the vehicle while the other is performing the test.

MEASURE STALL SPEED

- Warm up the transmission fluid.
- Check the front and rear wheels.
- Connect a tachometer to the engine.
- Fully apply the parking brake.
- Keep your left foot pressed firmly on the brake pedal.
- Start the engine.
- Shift into the D range. Step all the way down on the accelerator pedal with your right foot. Quickly read the stall speed at this time.

NOTICE: Release the accelerator pedal and stop test if the rear wheels begin to rotate before the engine speed reaches specified stall speed.

Stall speed:

(1FZ-FE engine)	2,150 ± 150rpm
(1HD-T engine)	1,950 ± 150rpm

- Perform the same test in R range.

EVALUATION

- If the stall speed is the same for both positions but lower than specified value:

- Engine output may be insufficient
- Stator one-way clutch is not operating properly

HINT: If more than 600 rpm below the specified value, the torque converter clutch could be faulty.

- If the stall speed in D range is higher than specified:

- Line pressure too low
- Forward clutch slipping
- No.2 one-way clutch not operating properly
- O/D one-way clutch not operating properly

- If the stall speed in R range is higher than specified:

- Line pressure too low
- Direct clutch slipping
- First and reverse brake slipping
- O/D one-way clutch not operating properly

- If the stall speed in both R and D ranges are higher than specified:

- Line pressure too low
- Improper fluid level
- O/D one-way clutch not operating properly

STALL TEST

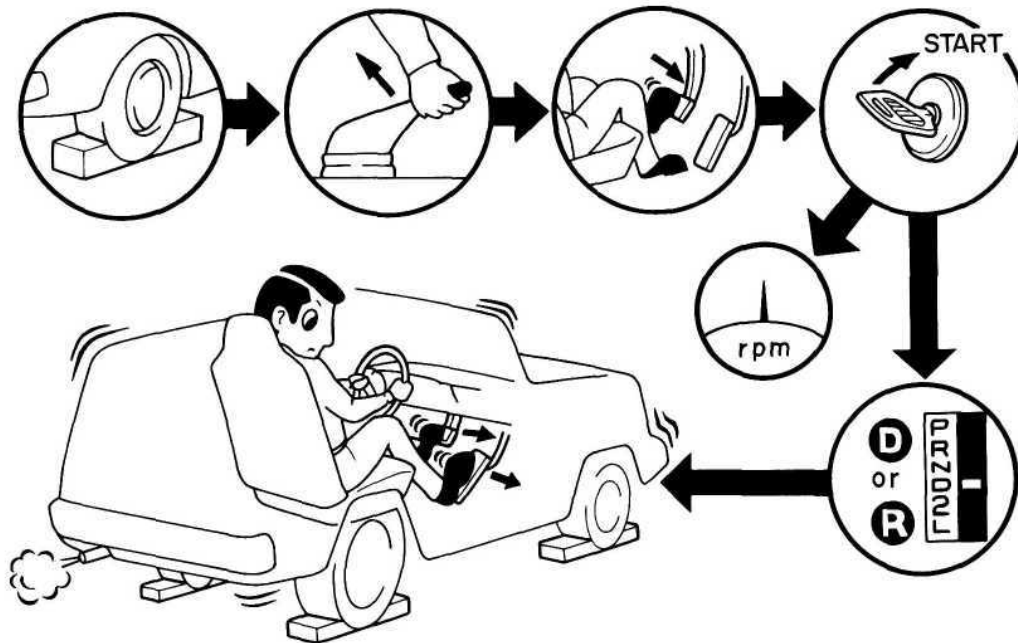

TIME LAG TEST

When the shift lever is shifted while the engine is idling, there will be a certain time elapse or lag before the shock can be felt. This is used for checking the condition of the O/D direct clutch, forward clutch, direct clutch and first and reverse brake.

NOTICE:

- Perform the test at normal operating fluid temperature (50 — 80°C or 122 — 176°F).
- Be sure to allow one minute interval between tests.
- Make three measurements and take the average value.

MEASURE TIME LAG

- Fully apply the parking brake.
- Start the engine and check the idle speed.

Idle speed:

650 rpm (N range)

- Shift the shift lever from N to D range. Using a stop watch, measure the time it takes from shifting the lever until the shock is felt.

Time lag:

Less than 1.0 seconds

- In same manner, measure the time lag for N → R.

Time lag:

Less than 1.5 seconds

EVALUATION

- If N → D time lag is longer than specified:
 - Line pressure too low
 - Forward clutch worn
 - O/D one-way clutch not operating properly
- If N → R time lag is longer than specified:
 - Line pressure too low
 - Direct clutch worn
 - First and reverse brake worn
 - O/D one-way clutch not operating properly

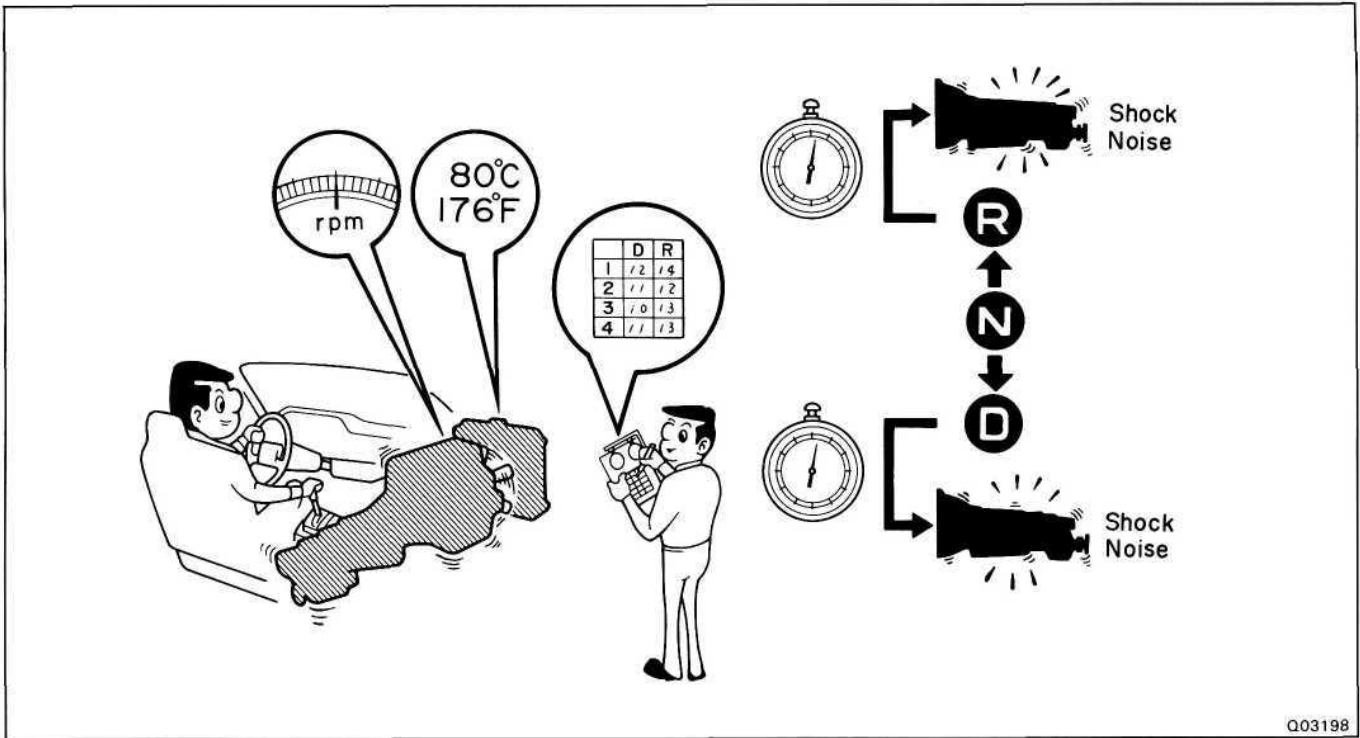

HYDRAULIC TEST

PREPARATION

- (a) Warm up the transmission fluid.
- (b) Remove the transmission case test plug and connect the hydraulic pressure gauge.
SST 09992-00094 (Oil pressure gauge)

NOTICE:

- Perform the test at normal operating fluid temperature (50 — 80°C or 122 — 176°F).
- The line pressure test should always be carried out in pairs. One should observe the conditions of wheels or wheel stoppers outside the vehicle while the other is performing the test.

MEASURE LINE PRESSURE

- (a) Fully apply the parking brake and chock the four wheels.
- (b) Start the engine and check idling rpm.
- (c) Keep your left foot pressed firmly on the brake pedal and shift into D range.
- (d) Measure the line pressure when the engine is idling.
- (e) Press the accelerator pedal all the way down. Quickly read the highest line pressure when engine speed reaches stall speed.

NOTICE: Release the accelerator pedal and stop test if the rear wheels begin to rotate before the engine speed reaches specified stall speed.

- (f) In the same manner, perform the test in R range.

(1FZ-FE engine)

kPa (kgf/cm², psi)

D range		R range	
Idling	Stall	Idling	Stall
461 — 520 (4.7 — 5.3, 68 — 77)	971 — 1,226 (9.9 — 12.5, 144 — 181)	657 — 843 (6.7 — 8.6, 97 — 125)	1,648 — 1,853 (16.8—18.9, 244—274)

(1HD-T engine)

D range		R range	
Idling	Stall	Idling	Stall
431 — 510 (4.4 — 5.2, 63 — 74)	971 — 1,226 (9.9 — 12.5, 141 — 178)	637 — 843 (6.5 — 8.6, 92 — 122)	1,608 — 1,853 (16.4—18.9, 233—269)

If the measured pressures are not up to specified values, recheck the throttle cable adjustment and perform a retest.

EVALUATION

- (a) If the measured values at all positions are higher than specified:
- Throttle cable out of adjustment
 - Throttle valve defective
 - Regulator valve defective
- (b) If the measured values at all positions are lower than specified:
- Throttle cable out of adjustment
 - Throttle valve defective
 - Regulator valve defective
 - Oil pump defective
 - O/D direct clutch defective
- (c) If pressure is low in the D range only:
- D range circuit fluid leakage
 - Forward clutch defective
- (d) If pressure is low in the R range only:
- R range circuit fluid leakage
 - Direct clutch defective
 - First and reverse brake defective

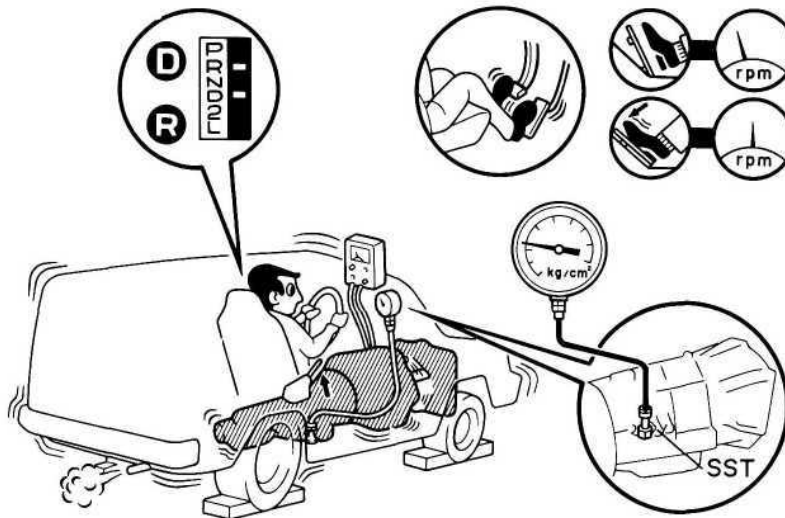
HYDRAULIC TEST

ROAD TEST

NOTICE: Perform the test at normal operating fluid temperature (50 - 80°C or 122 - 176°F).

1. D RANGE TEST IN NORM AND PWR PATTERN RANGES

Shift into the D range and hold the accelerator pedal constant at the full throttle valve opening position.

Check the following:

- (a) 1 — 2, 2 — 3 and 3 — O/D up-shifts should take place, and shift points should conform to those shown in the automatic shift schedule.

Conduct a test under both Normal and Power patterns.

HINT: There is no O/D up-shift or lock-up when the coolant temperature is below 55°C (131 °F).

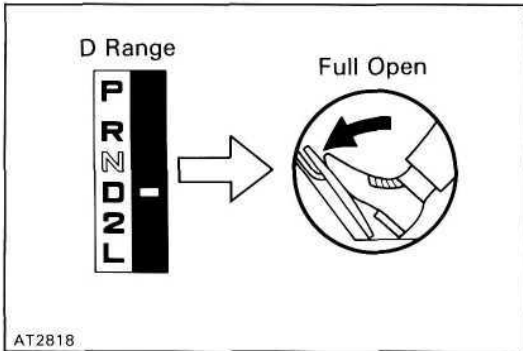

EVALUATION

- (1) If there is no 1 → 2 up-shift:
 - No.2 solenoid is stuck.
 - 1 — 2 shift valve is stuck.
- (2) If there is no 2 → 3 up-shift:
 - No.1 solenoid is stuck.
 - 2 — 3 shift valve is stuck.
- (3) If there is no 3 → O/D up-shift:
 - 3 — 4 shift valve is stuck.
- (4) If the shift point is defective:
 - Throttle valve, 1 — 2 shift valve, 2 — 3 shift valve, 3 — 4 shift valve etc., are defective.
- (5) If the lock-up is defective:
 - Lock-up solenoid is stuck.
 - Lock-up relay valve is stuck.

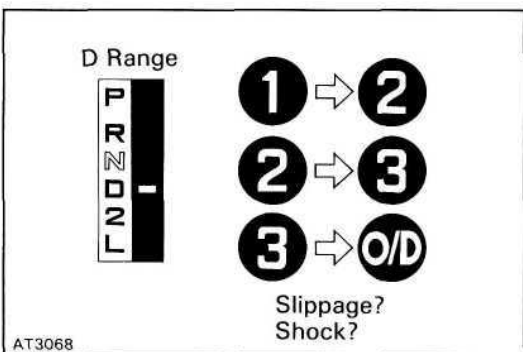

- (b) In the same manner, check the shock and slip at the 1 → 2, 2 → 3, and 3 → O/D up-shifts.

EVALUATION

If the shock is excessive:

- Line pressure is too high.
- Accumulator is defective.
- Check ball is defective.

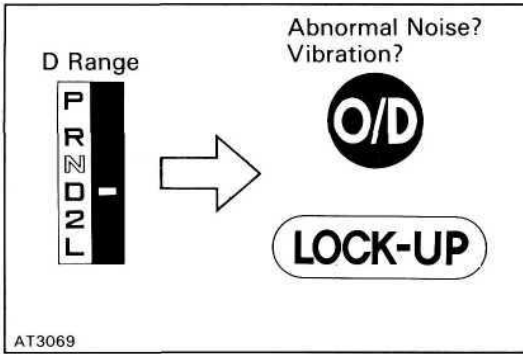

- (c) Run at the D Range lock-up or O/D gear and check for abnormal noise and vibration.

HINT: The check for the cause of abnormal noise and vibration must be made with extreme care as it could also be due to loss of balance in the propeller shaft, differential, torque converter, etc.

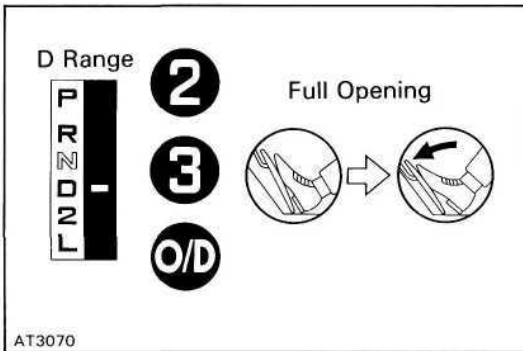

- (d) While running in the D range, 2nd, 3rd and O/D gears, check to see that the possible kick-down vehicle speed limits for 2 → 1, 3 → 2 and O/D → 3 kick-downs conform to those indicated on the automatic shift schedule.

- (e) Check for abnormal shock and slip at kick-down.

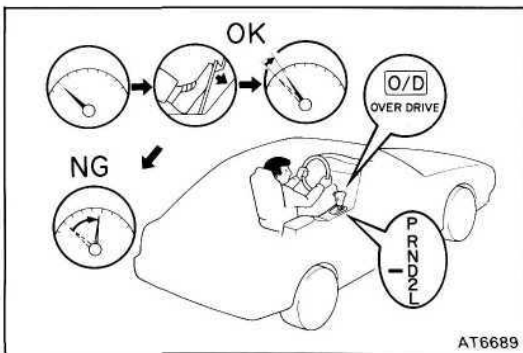

- (f) Check for the lock-up mechanism.

- (1) Drive in D position, O/D gear, at a steady speed (lock-up ON) of about 95 km/h (59 mph).
- (2) Lightly depress the accelerator pedal and check that the engine rpm does not change abruptly.

If there is a big jump in engine rpm, there is no lock-up.

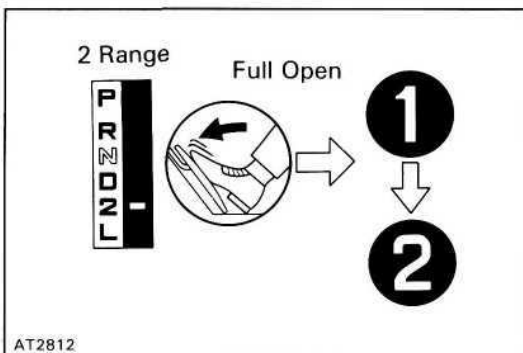

2. 2 RANGE TEST

Shift into the 2 range and, while driving with the accelerator pedal held constantly at the full throttle valve opening position, push in one of the pattern selectors and check on the following points.

- (a) Check to see that the 1 → 2 up-shift takes place and that the shift point conforms to it shown on the automatic shift schedule.

HINT: There is no O/D upshift and lock-up in the 2 position.

- (b) While running in the 2 range and 2nd gear, release the accelerator pedal and check the engine braking effect.

EVALUATION

If there is no engine braking effect:

- Second coast brake is defective.

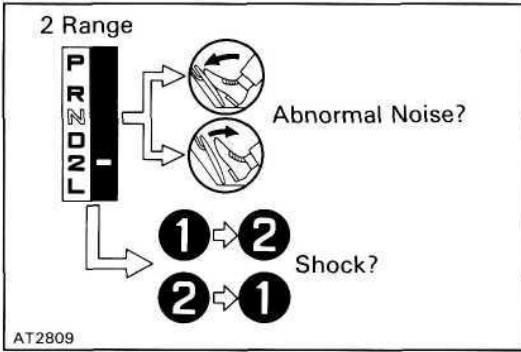

- (c) Check for abnormal noise at acceleration and deceleration, and for shock at up-shift and down-shift.

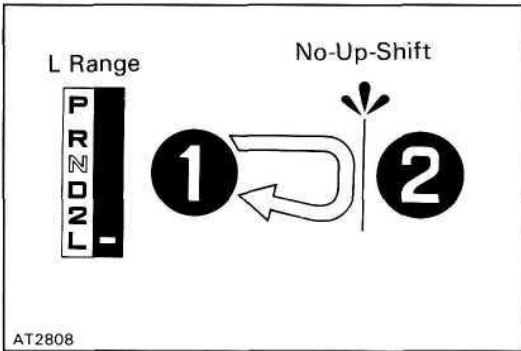

3. L RANGE TEST

- (a) While running in the L range, check to see that there is no up-shift to 2nd gear.

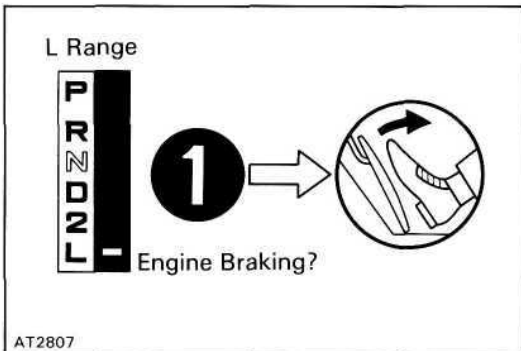

- (b) While running in the L range, release the accelerator pedal and check the engine braking effect.

EVALUATION

If there is no engine braking effect:

- First and reverse brake is defective.

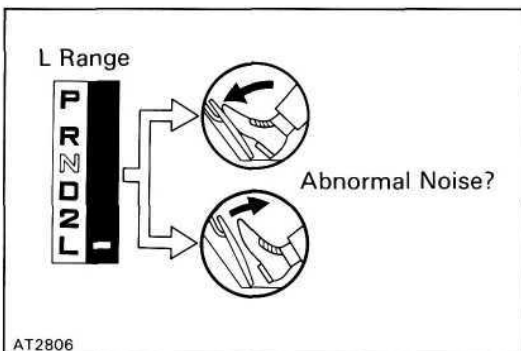

- (c) Check for abnormal noise during acceleration and deceleration.

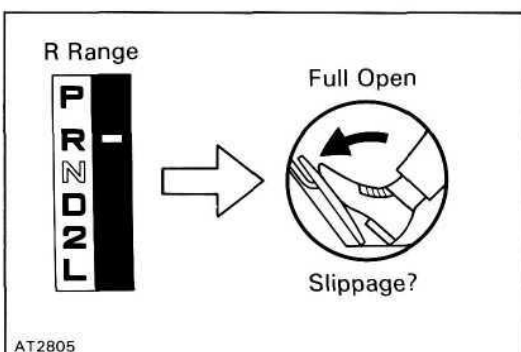

4. R RANGE TEST

Shift into the R range and, while starting at full throttle, check for slippage.

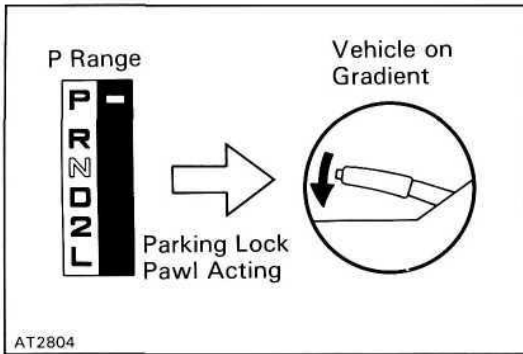
**5. P RANGE TEST**

Stop the vehicle on a gradient (more than 5°) and after shifting into the P range, release the parking brake. Then check to see that the parking lock pawl holds the vehicle in place.

(OFF - VEHICLE)

See Page		AT-76		★	★	★	★	★	★	★	★	★	★	★	★
Parts Name		Torque converter		Oil pump	O/D brake (B ₀)	2nd brake (B ₁)	1st and reverse brake (B ₂)	O/D direct clutch (C ₀)	Front clutch (C ₁)	Rear clutch (C ₂)	O/D one-way clutch (F ₀)	No.2 one-way clutch (F ₂)	ON-Vehicle matrix chart	Front planetary gear	Rear planetary gear
Trouble		Torque converter		Oil pump	O/D brake (B ₀)	2nd brake (B ₁)	1st and reverse brake (B ₂)	O/D direct clutch (C ₀)	Front clutch (C ₁)	Rear clutch (C ₂)	O/D one-way clutch (F ₀)	No.2 one-way clutch (F ₂)	ON-Vehicle matrix chart	Front planetary gear	Rear planetary gear
Does not move in any forward range									1						
Does not move in reverse range							3			2			1		
Does not move in any range		1	3					2			4			5	6
No up-shift	1st → 2nd					2						3	1		
	2nd → 3rd							2	3				1		
	3rd → O/D				2								1		
No down-shift	O/D → 3rd							2			3		1		
	3rd → 2nd						2						1		
	2nd → 1st							2				3	1		
Shift point too high or too low													1		
Harsh engagement	"N" → "R"						3			2			1		
	"N" → "D"								2			3	1		
	"N" → "D", "N" → "R"							2			3		1		
	1st → 2nd					2							1		
	2nd → 3rd							3		2			1		
	3rd → O/D				2								1		
	1st → 2nd → 3rd → O/D								2				1		
	O/D → 3rd							2			3		1		
3rd → 2nd					2							1			
Slip	Forward & Reverse	2	3								4		1		
	"R" range						2			1					
	1st								1			2			
	2nd								2						
	3rd								2	3					
	O/D			3					1	2					
No engine braking	1st ("L" range)						2						1		
	2nd ("2" range)							2					1		
No kick-down													1		
Poor acceleration		2						3					1		
No lock-up		2											1		

Remark ★ : Refer to A442F Automatic Transmission Repair Manual. (Pub. No. RM314E)

VALVE BODY

VALVE BODY REMOVAL

1. REMOVE TRANSMISSION AND TRANSFER UNDER COVER

2. CLEAN TRANSMISSION EXTERIOR

To prevent contamination, clean the exterior transmission.

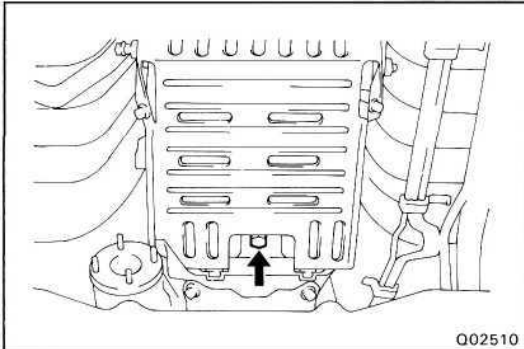

3. DRAIN TRANSMISSION FLUID

Remove the drain plug and drain fluid into a suitable container.

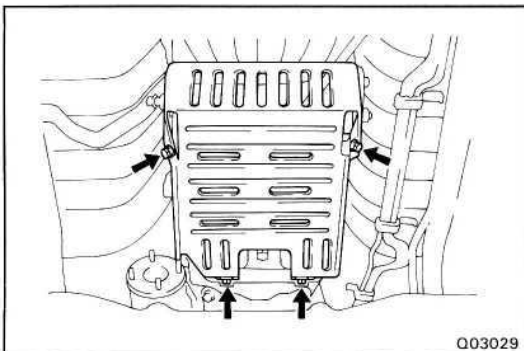

4. REMOVE OIL PAN PROTECTOR

Remove the four bolts and the oil pan protector.

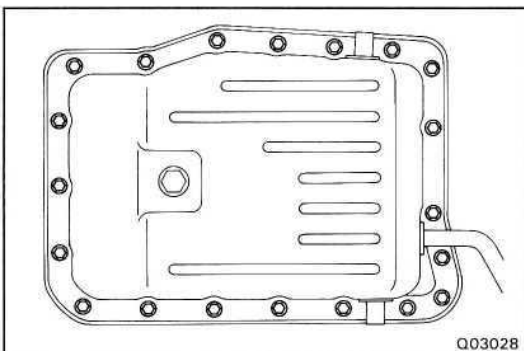

5. REMOVE OIL PAN AND GASKET

NOTICE: Some fluid will remain in the oil pan. Be careful not to damage the filler tube.

- (a) Remove the twenty bolts.

- (b) Install the blade off SST between the transmission and oil pan, cut-off applied sealer.

SST 09302-00100

NOTICE: Be careful not to damage the oil pan flange.

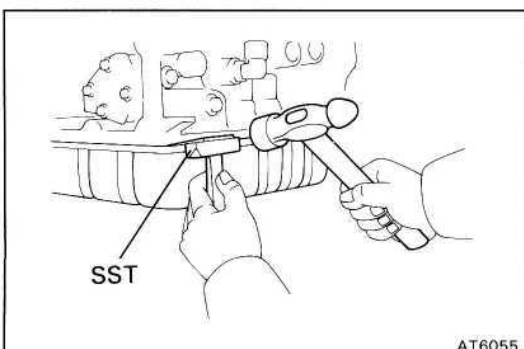

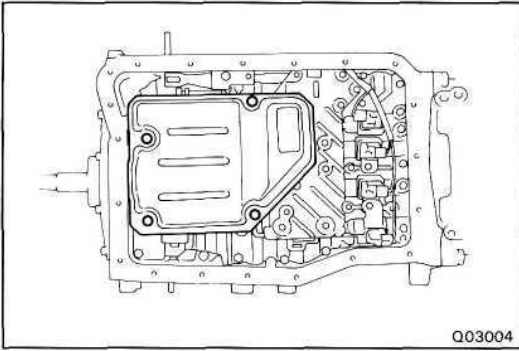

6. REMOVE OIL STRAINER

Remove the four bolts and oil strainer.

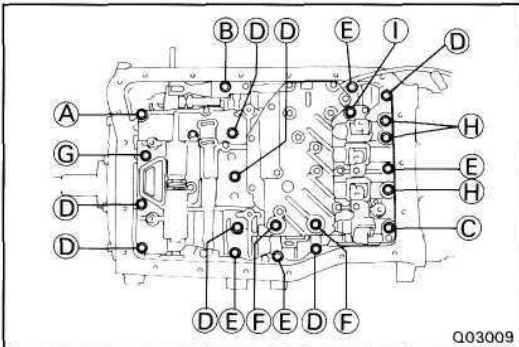

7. REMOVE VALVE BODY

(a) Remove the twenty-one bolts.

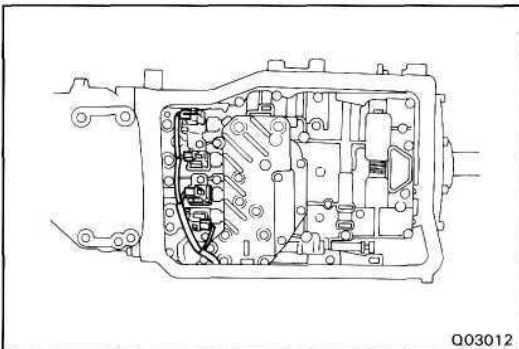

(b) Disconnect the four connectors from the solenoids.

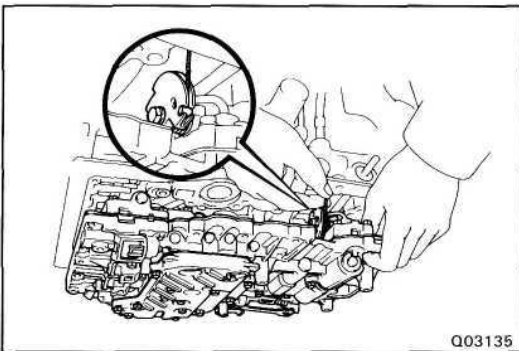

(c) Remove the throttle cable the cam and remove the valve body.

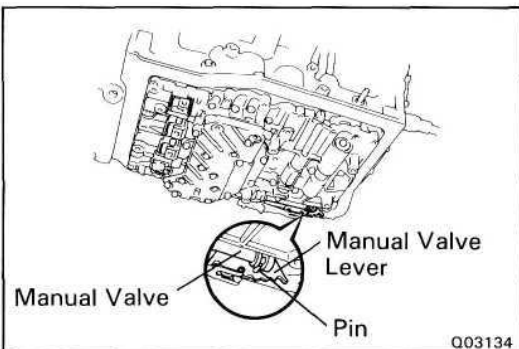

VALVE BODY INSTALLATION

1. INSTALL VALVE BODY

(a) Align the groove of the manual valve with the pin of the manual valve lever.

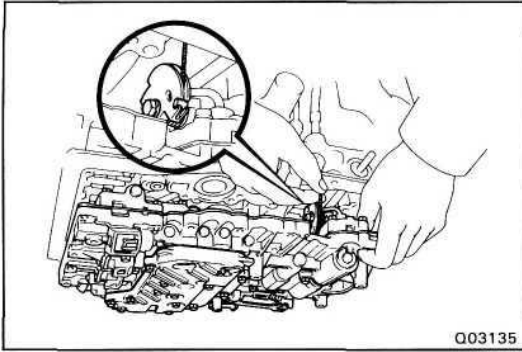

(b) Connect the throttle cable to the cam.

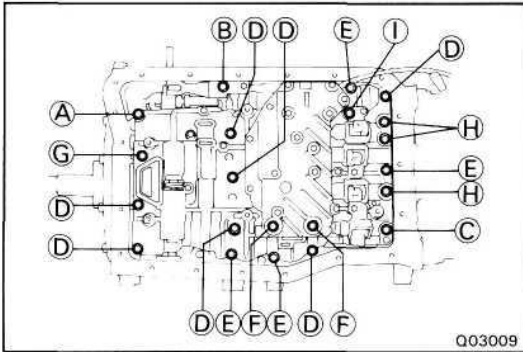

(c) Install the other bolts.

HINT: Each bolt length is indicated below.

Bolt length:

- A 41 mm (1.61 in.)
- B 45 mm (1.77 in.)
- C 22 mm (0.87 in.)
- D 32 mm (1.26 in.)
- E 28 mm (1.10 in.)
- F 52 mm (2.05 in.)
- G 40 mm (1.57 in.)
- H 22 mm (0.87 in.)
- I 42 mm (1.65 in.)

(d) Check that the manual valve lever contacts the center of the roller at the tip of the detente spring.

(e) Tighten the bolts.

Torque: 10 Nm (100 kgf-cm, 7 ft-lbf)

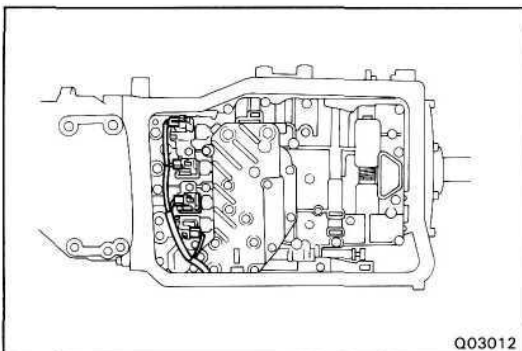

2. CONNECT FOUR SOLENOID CONNECTORS

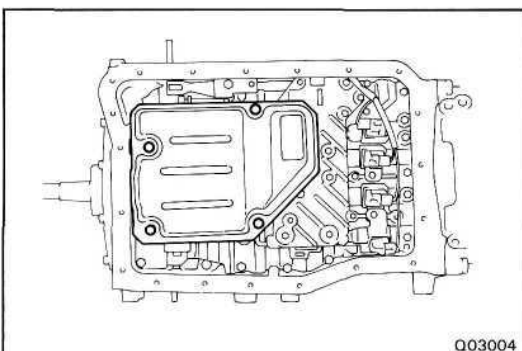

3. INSTALL OIL STRAINER

Install a new gasket and the oil strainer with the four bolts.

Torque: 10 Nm (100 kgf-cm, 7 ft-lbf)

Bolt length:

16 mm (0.63 in.)

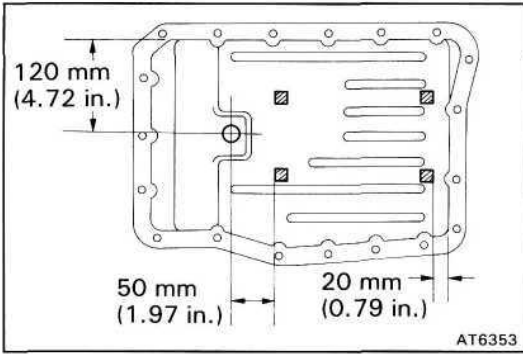

4. INSTALL MAGNETS IN PAN

Install the two magnets in the oil pan as shown in the illustration.

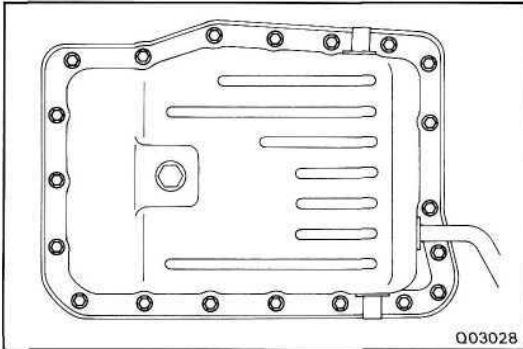

5. INSTALL OIL PAN

- (a) Remove any packing material and be careful not to drop oil on the contacting surface of the transmission case and oil pan.
- (b) Apply seal packing to the oil pan.

Seal packing:

Part No. 08826-00090, THREE BOND 1281B or equivalent

- (c) Install and tighten the twenty bolts.

Torque: 6.9 N·m (70 kgfcm, 61 in.lbf)

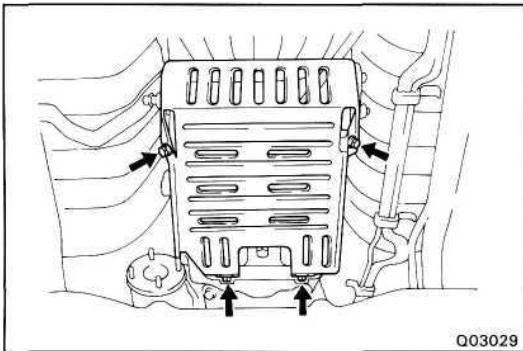

6. INSTALL OIL PAN PROTECTOR

Install the protector with the four bolts.

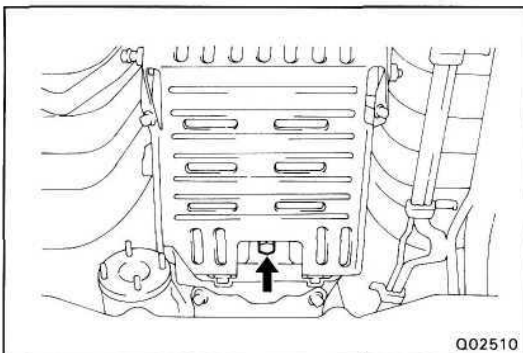

7. INSTALL DRAIN PLUG

- (a) Install the drain plug with a new gasket.
- (b) Torque the drain plug.

Torque: 27 Nm (280 kgfcm, 20 ftlbf)

8. INSTALL TRANSMISSION UNDER COVER AND TRANSFER UNDER COVER

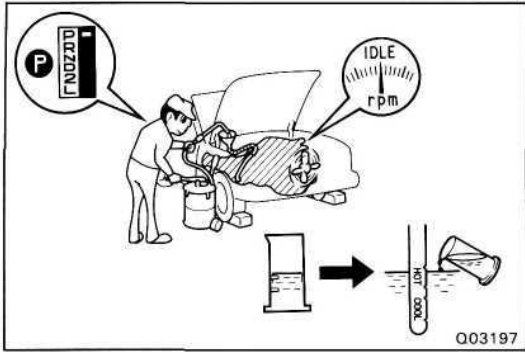

9. FILL TRANSMISSION WITH ATF

Capacity:

6.0 liters (6.3 US qts, 5.3 Imp.qts)

NOTICE: Do not overfill.

Fluid type:

ATF DEXRON® II

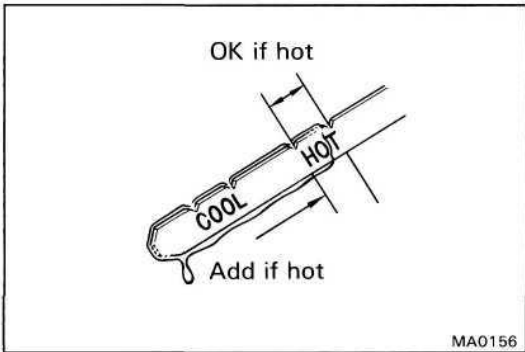

10. CHECK FLUID LEVEL

(See page AT-25)

THROTTLE CABLE

THROTTLE CABLE REMOVAL

1. **REMOVE FRONT PROPELLER SHAFT**
(See Pub No. RM184E, page PR-3)
2. **DISCONNECT THROTTLE CABLE**
 - (a) Disconnect the cable housing from the bracket.
 - (b) Disconnect the cable from the throttle linkage.
 - (c) Disconnect the cable from the torque converter housing.
3. **REMOVE VALVE BODY**
(See page AT-58)

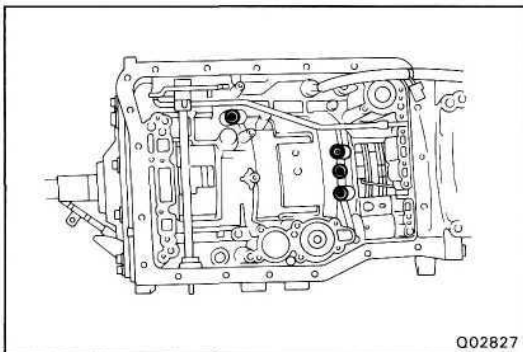

4. **REMOVE FOUR CENTER SUPPORT APPLY GASKETS**

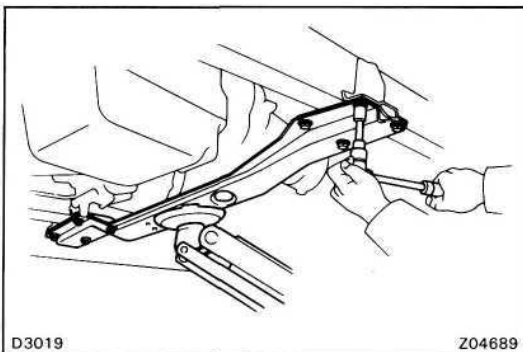

5. **REMOVE FRAME CROSSMEMBER SET BOLTS**

- (a) Support the frame crossmember with a jack.
- (b) Remove the eight set bolts.

6. **REMOVE THROTTLE CABLE CLAMP**

- (a) Lower the jack.
- (b) Remove the cable clamp from the transmission housing.

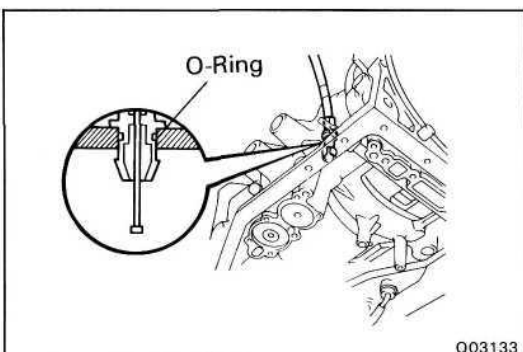

7. **REMOVE THROTTLE CABLE**

Using 10 mm socket driver, remove the throttle cable by pushing the retainer portion of the throttle cable.

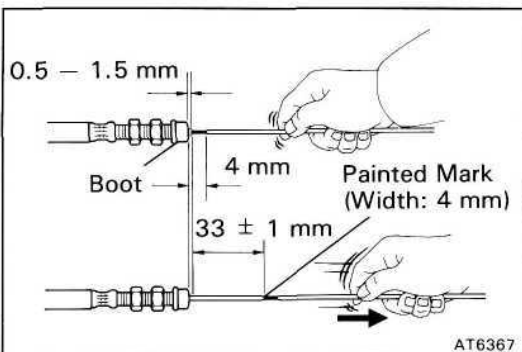
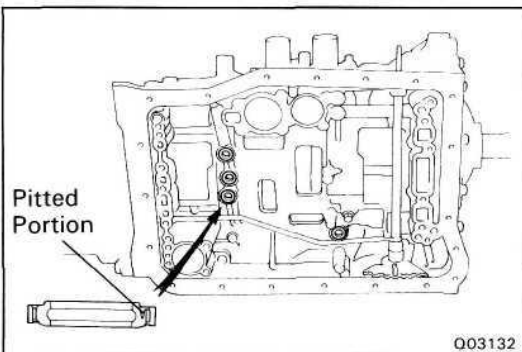
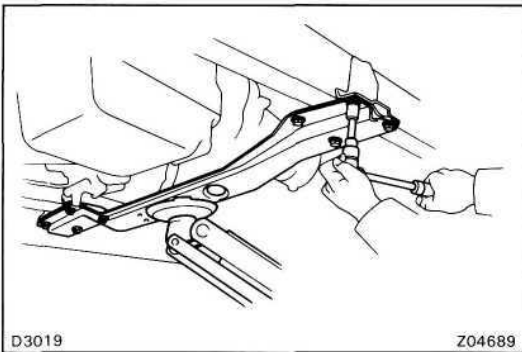
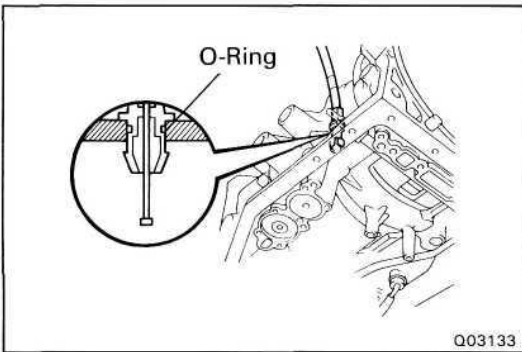

THROTTLE CABLE INSTALLATION

1. INSTALL CABLE IN TRANSMISSION CASE

- (a) Coat a new O-ring with ATF, and install it to the cable.
- (b) Install the cable to the transmission case.

2. INSTALL THROTTLE CABLE CLAMP TO TRANSMISSION HOUSING

3. INSTALL FRAME CROSSMEMBER SET BOLTS

Torque: 61 Nm (620 kgfcm, 45 ftlbf)

4. INSTALL FOUR CENTER SUPPORT APPLY GASKET

Install new four gaskets, facing the pitted side toward the transmission case.

5. INSTALL VALVE BODY (See page AT-59)

6. INSTALL FRONT PROPELLER SHAFT (See Pub No. RM184E. page PR-8)

7. IF THROTTLE CABLE IS NEW, PAINT MARK ON INNER CABLE

HINT: New cable do not have a cable stopper installed. Therefore to mark adjustment possible, paint a mark as described below.

- (a) Connect the throttle cable to the throttle cam of valve body.
- (b) Pull the inner cable lightly until resistance is felt, and hold it.
- (c) Paint a mark as shown, about 4 mm (0.16 in.) in width.
- (d) Pull the inner cable fully, measure the cable stroke.

Cable stroke:

33 ± 1 mm (1.30 ± 0.04 in.)

8. CONNECT THROTTLE CABLE

- (a) Connect the cable to the throttle linkage.
- (b) Connect the cable housing to the bracket on the valve cover.

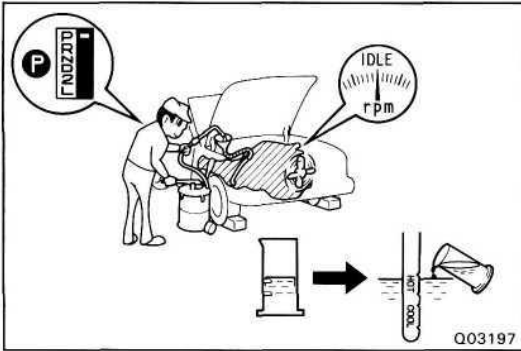

9. ADJUST THROTTLE CABLE
(See page AT-26)

10. FILL TRANSMISSION WITH ATF

Capacity:

6.0 liters (6.3 US qts, 5.3 Imp.qts)

NOTICE: Do not overfill.

Fluid type:

ATF DEXRON® H

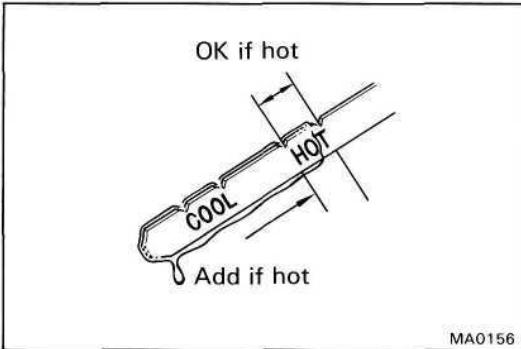

11. CHECK FLUID LEVEL
(See page AT-25)

ASSEMBLY REMOVAL AND INSTALLATION COMPONENTS

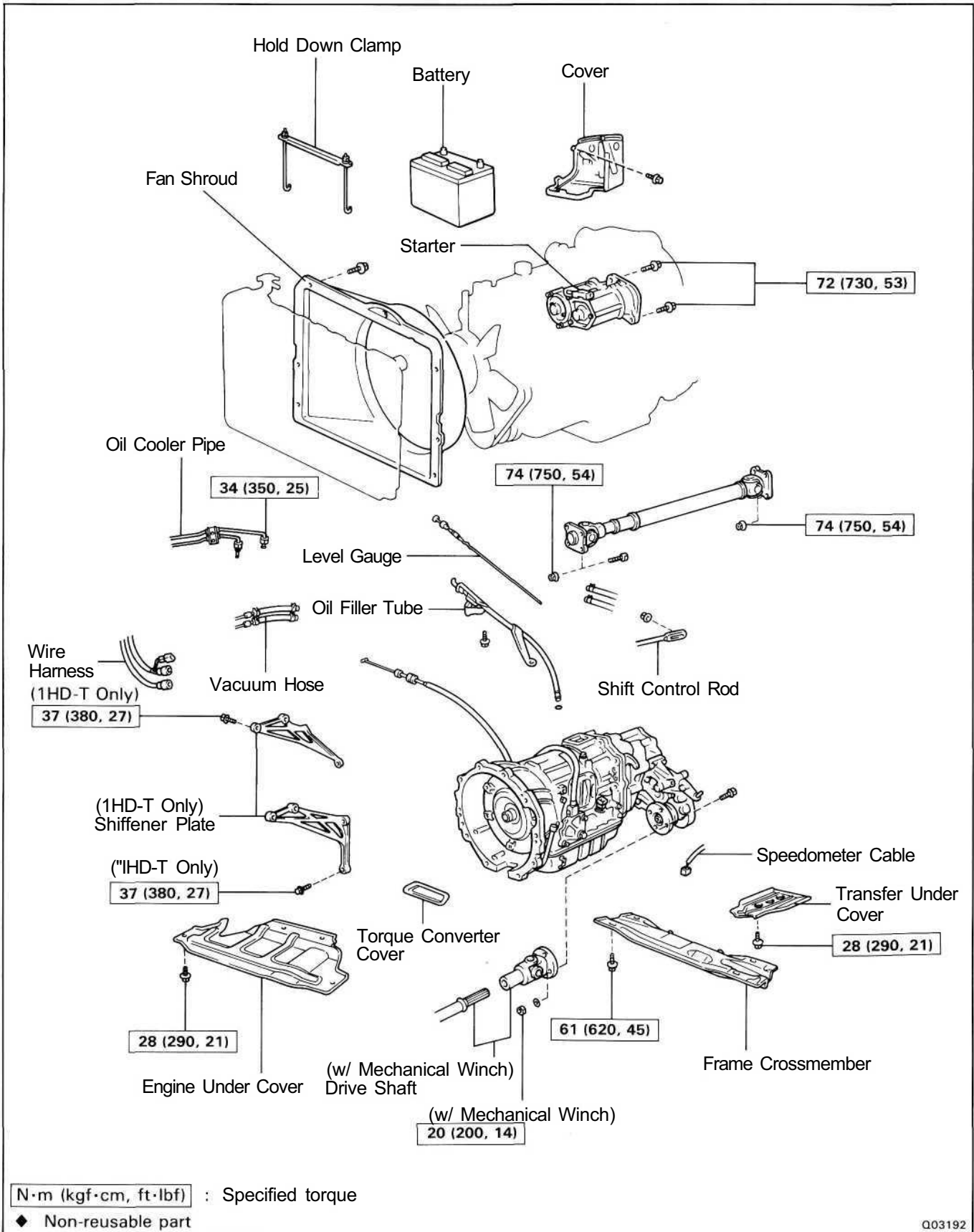

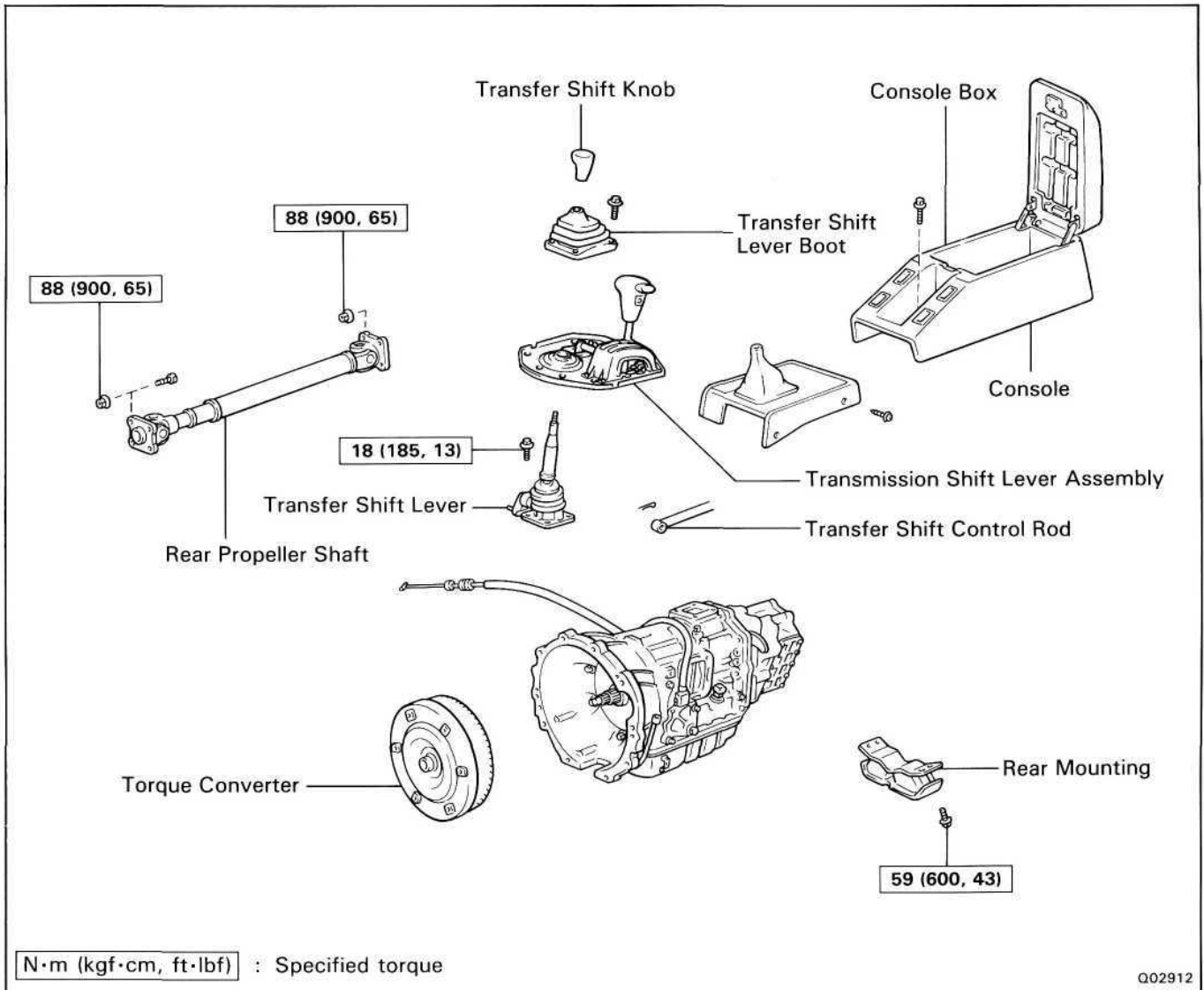

TRANSMISSION REMOVAL

1. DISCONNECT BATTERY CABLE FROM NEGATIVE TERMINAL
2. REMOVE BATTERY AND COVER
3. LOOSEN FAN SHROUD OF COOLING FAN TO AVOID DAMAGE TO FAN

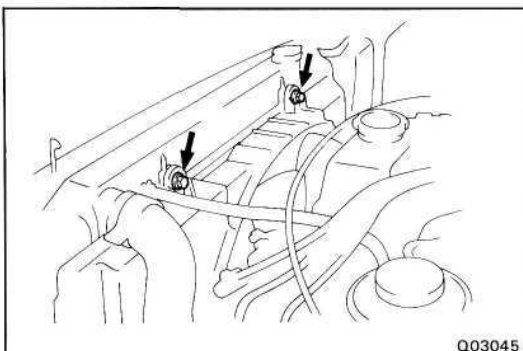

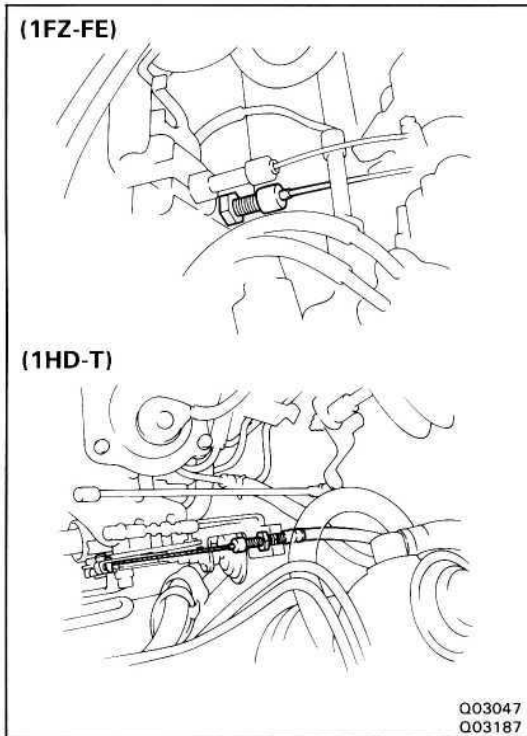
**4. DISCONNECT THROTTLE CABLE**

- (a) Loosen the adjusting nut and disconnect the cable housing from the bracket.
- (b) Disconnect the cable from the linkage.

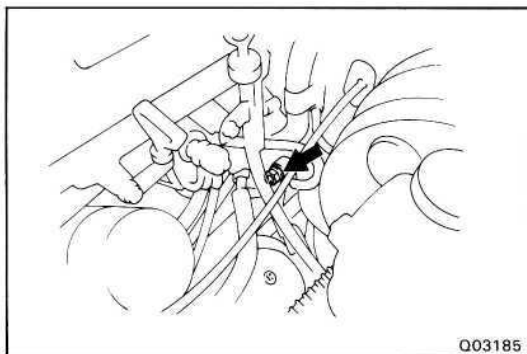
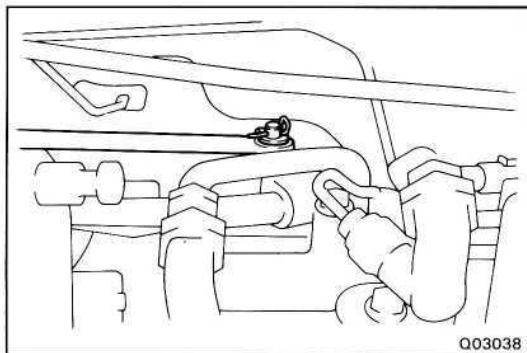
**5. (1HD-T)
REMOVE STARTER MOUNTING BOLT****6. REMOVE TRANSMISSION SELECT LEVER AND TRANSFER SHIFT LEVER**

- (a) Remove the clip, washer and wave washer, and disconnect the link.

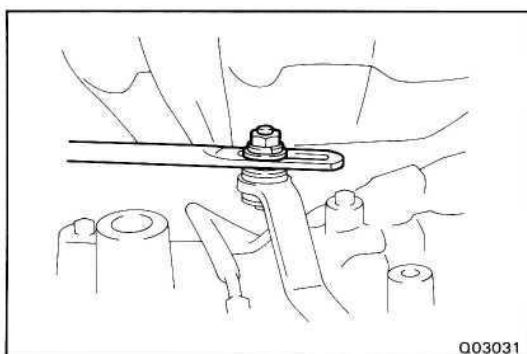

- (b) Remove the nut and washer, disconnect the link.

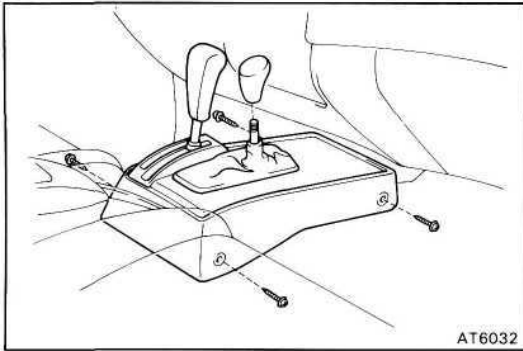

- (c) Remove the transfer shift lever knob.
- (d) Remove the four screws and the console.

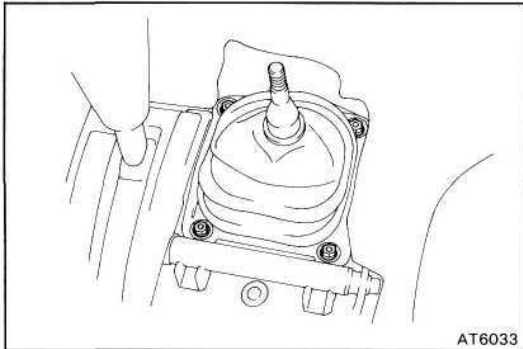

- (e) Remove the four bolts and transfer shift lever bolt.

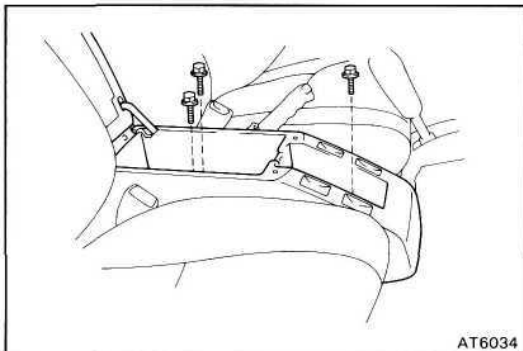

- (f) Remove the three bolts and the console box.

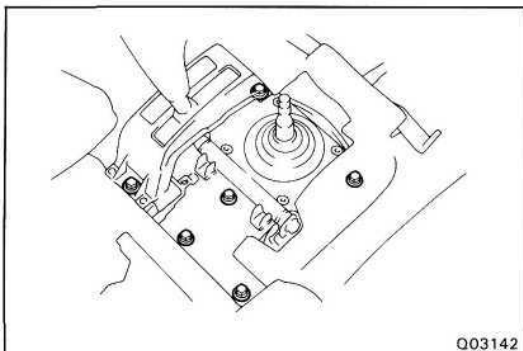

- (g) Remove the six bolts and the transmission shift lever assembly.

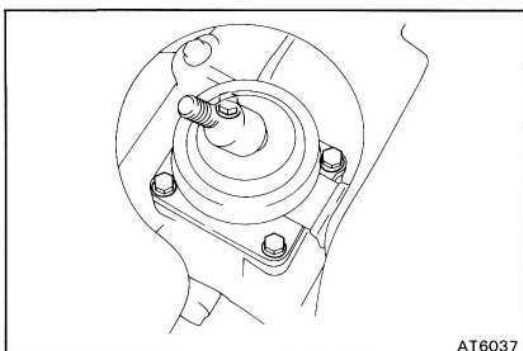

- (h) Remove the four screws and the transfer shift lever.

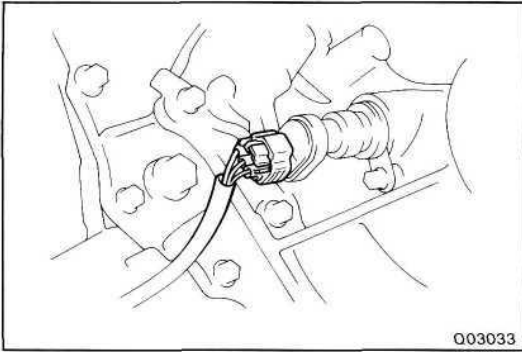

7. REMOVE NO.1 SPEED SENSOR CONNECTOR
8. REMOVE FRONT AND REAR PROPELLER SHAFTS
(See Pub. No. RM184E, page PR-3)

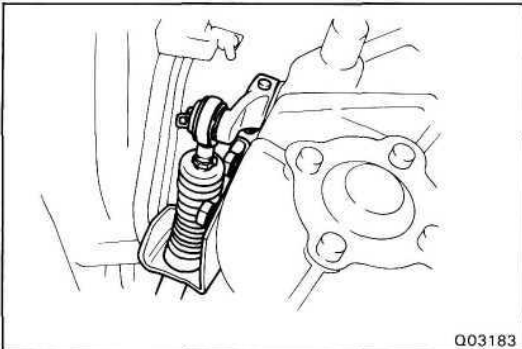

9. (w/ MECHAICAL WINCH)
REMOVE POWER TAKE OF SHIFT CABLE
 - (a) Pull out the pin and disconnect the cable.
 - (b) Remove the two bolts and the cable bracket.

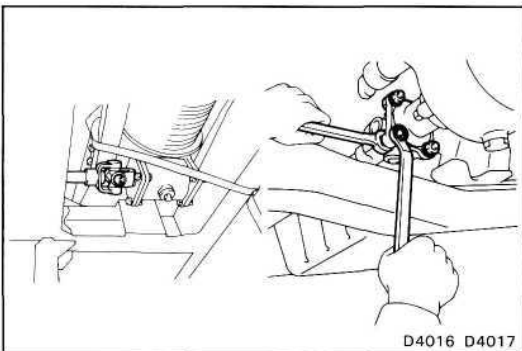

- (c) Remove the engine under cover.
- (d) Place matchmarks on the yoke and flange.
- (e) Remove the bolts and nuts, disconnect the drive shaft from the PTO.

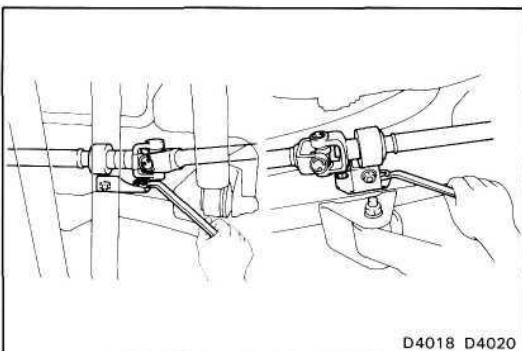

- (f) Remove the front and rear bracket set bolts, and then remove the drive shaft.

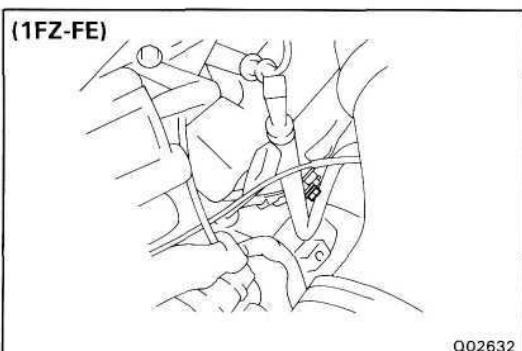

10. REMOVE OIL FILLER TUBE
 - (a) Remove the level gauge.
 - (b) Remove the bolt.

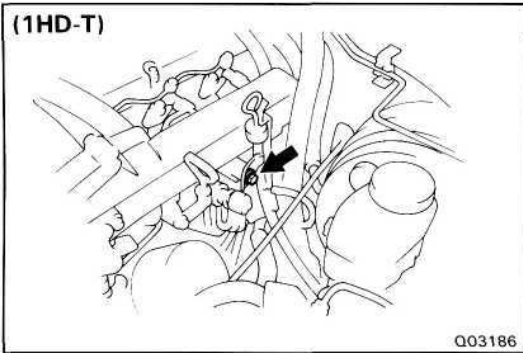

- (c) Remove the bolt and the filler tube.

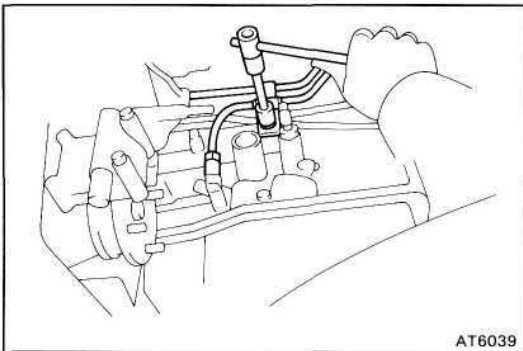
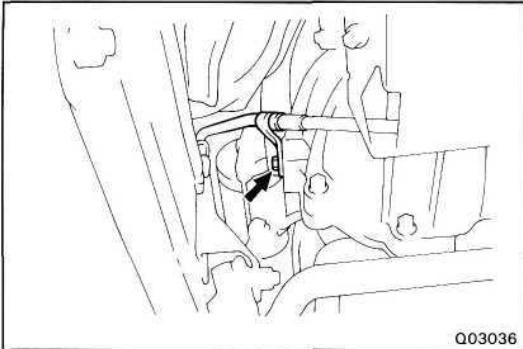

11. DISCONNECT TWO OIL COOLER TUBES

- (a) Remove the bolt and clamp.

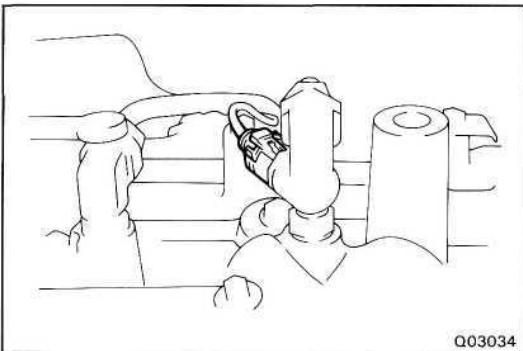

- (b) Disconnect the temperature sensor connector.

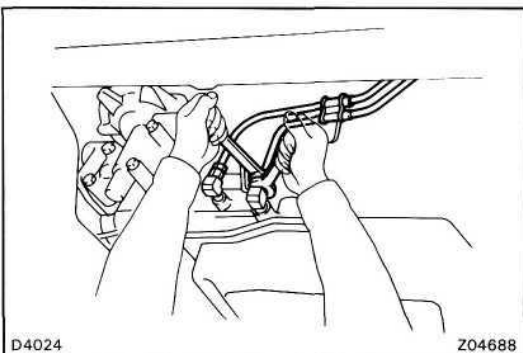

- (c) Disconnect the two oil cooler tubes.

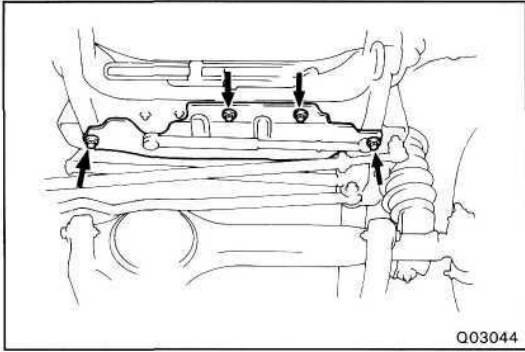

12. REMOVE ENGINE UNDER COVER

Remove the four bolts and the cover.

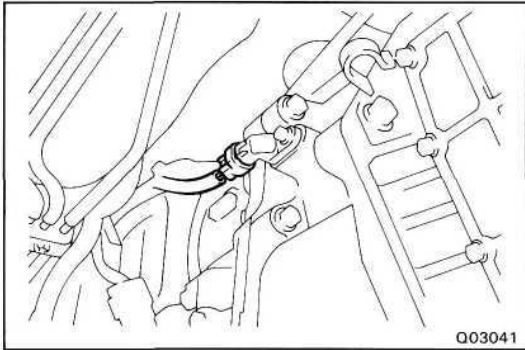

13. DISCONNECT NO.2 SPEED SENSOR CONNECTOR

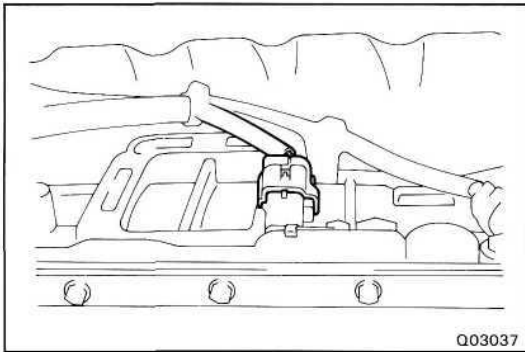

14. DISCONNECT SOLENOID CONNECTOR

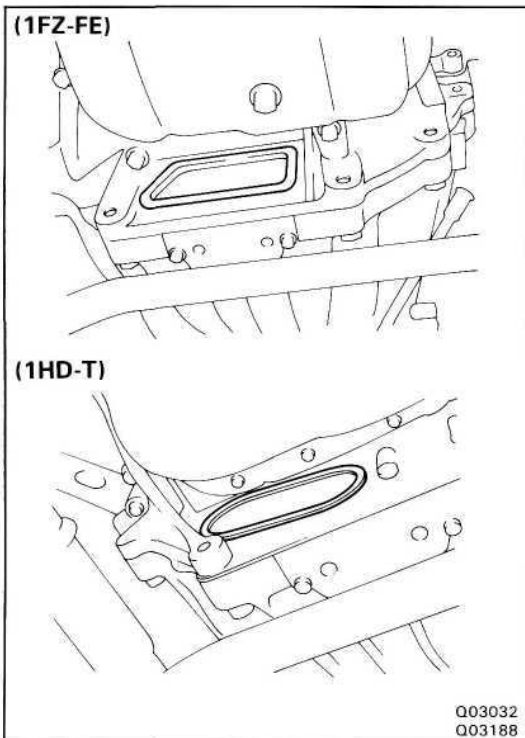

15. REMOVE SIX TORQUE CONVERTER MOUNTING BOLTS

(a) Remove the converter hole plug.

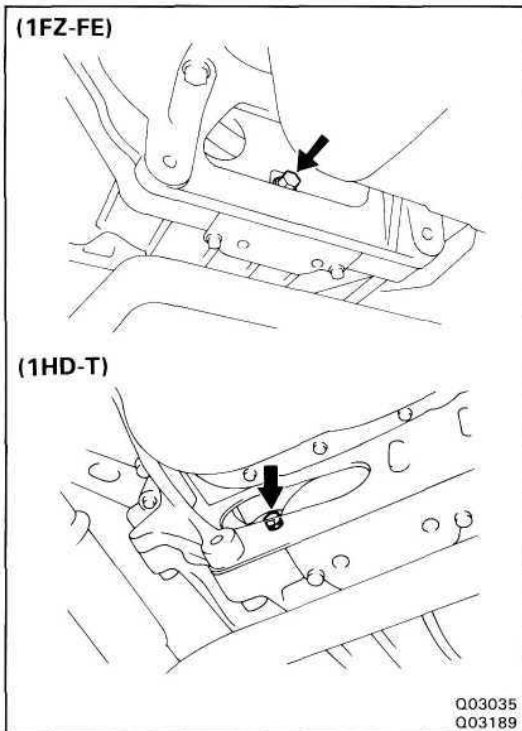

- (b) Turn the crankshaft to gain access to each bolt. Remove the six bolt.

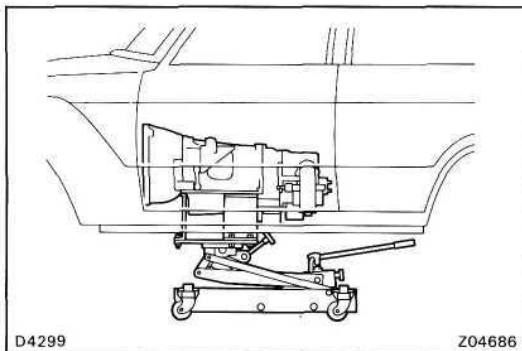

16. REMOVE CROSSMEMBER

- (a) Support the transmission with the transmission jack.

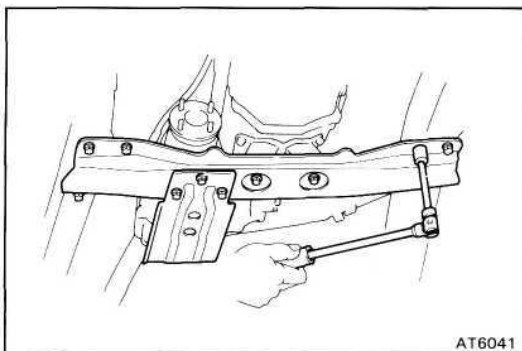

- (b) Remove the eight bolts and then remove the frame cross-member.

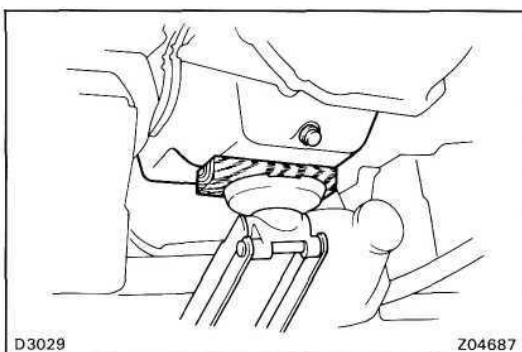

17. REMOVE TRANSMISSION ASSEMBLY

- (a) Be sure to put a wooden block or equivalent between the jack and oil pan to prevent damage. Support the oil pan with a jack.
 (b) Lower the rear end of transmission.

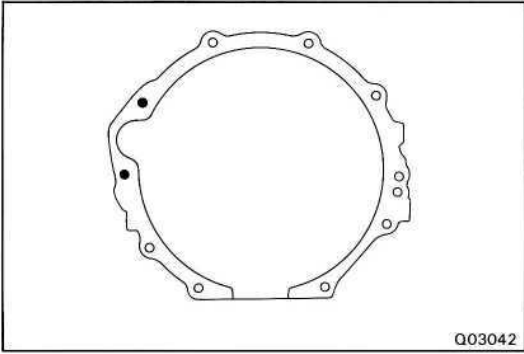

- (o) (1FZ-FE)
Remove the nut and disconnect the connectors from the starter.
- (d) (1FZ-FE)
Remove the two bolts and the starter.

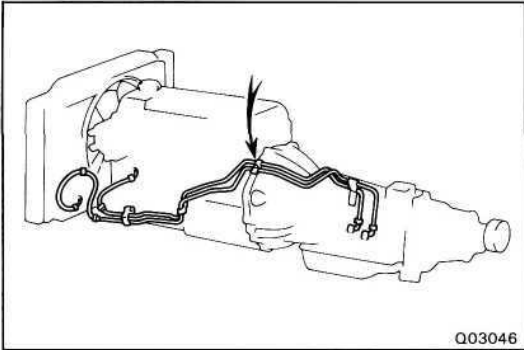

- (e) Disconnect the neutral start switch connectors.
- (f) Remove the bolt and disconnect the oil cooler tube clamp from the converter housing.
- (g) Disconnect the connectors from the transfer.
- (h) Remove the clamp and disconnect the wire harness from the transmission and transfer.

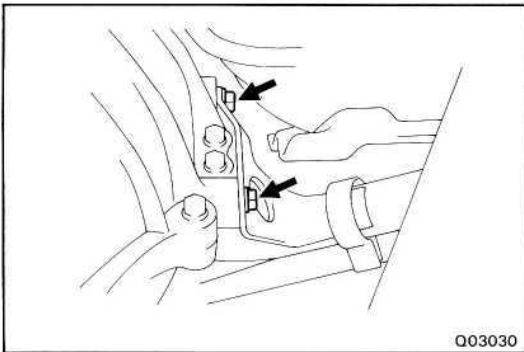

- (i) Remove the two bolts and disconnect the exhaust pipe bracket from the converter housing.

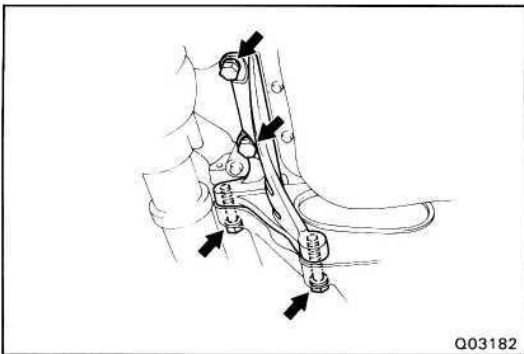

- (j) (1HD-T)
Remove the four bolts and the stiffener plate.

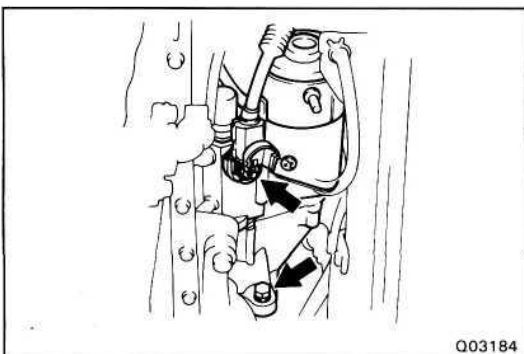

- (k) (1HD-T)
Remove the nut and disconnect the connectors from the starter.
- (l) (1HD-T)
Remove the nut and the starter.

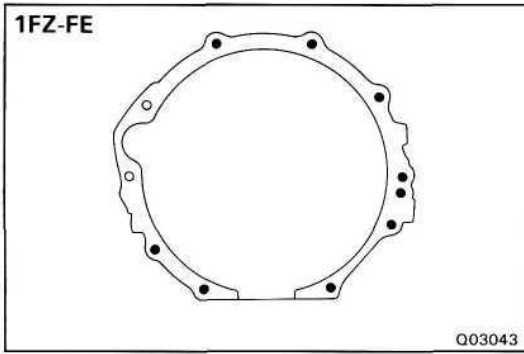

(m) Remove the bolts and the transmission.

TORQUE CONVERTER CLEANING

If the transmission is contaminated, the torque converter and transmission cooler should be thoroughly flashed with ATF.

TORQUE CONVERTER AND DRIVE PLATE INSPECTION

1. INSPECT ONE-WAY CLUTCH

- (a) Install SST in the inner race of one-way clutch.

SST 09350-30020 (09351-32010)

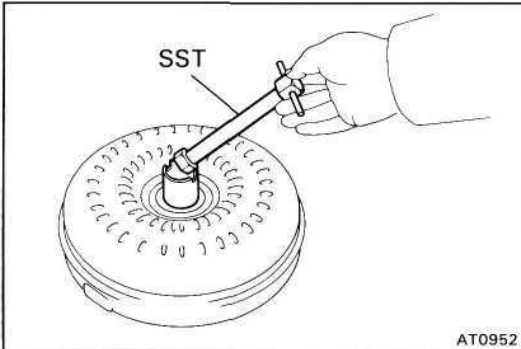

- (b) Install SST so that it fits in the notch of the converter hub and outer race of the one-way clutch.

SST 09350-30020 (09351-32010)

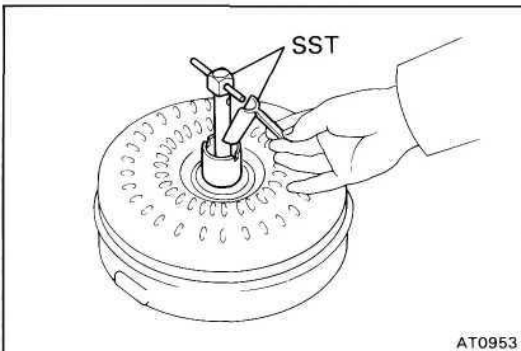

- (c) With the torque converter made stand, the clutch should lock when turned counterclockwise, and rotate freely and smoothly clockwise.

If necessary, clean the converter and retest the clutch. Replace the converter if the clutch still fails the test.

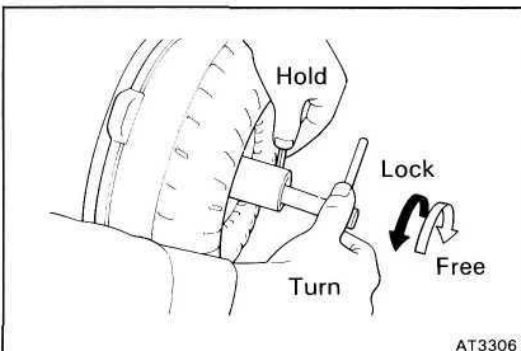

2. MEASURE DRIVE PLATE RUNOUT AND INSPECT RING GEAR

Set up a dial indicator and measure the drive plate runout. If runout exceeds 0.20 mm (0.0079 in.) or if the ring gear is damaged, replace the drive plate. If installing a new drive plate, note the orientation of spacers and tighten the bolts.

Torque: 83 Nm (850 kgfcm, 61 ft-lbf)

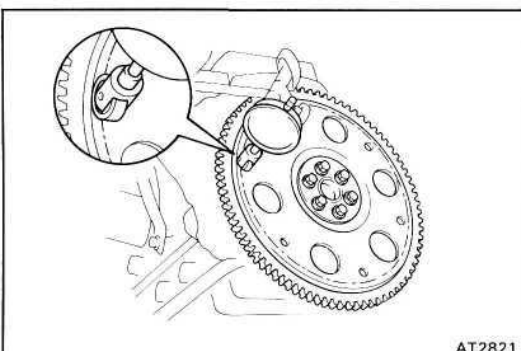

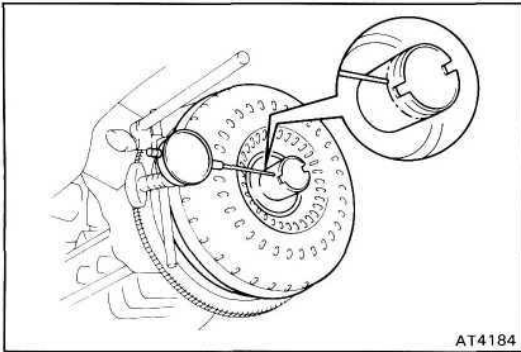

AT4184

3. MEASURE TORQUE CONVERTER SLEEVE RUNOUT

- (a) Temporarily mount the torque converter to the drive plate. Set up a dial indicator.

If runout exceeds 0.30 mm (0.0118 in.), try to correct by reorienting the installation of the converter. If excessive runout cannot be corrected, replace the torque converter.

HINT: Mark the position of the converter to ensure correct installation.

- (b) Remove the torque converter.

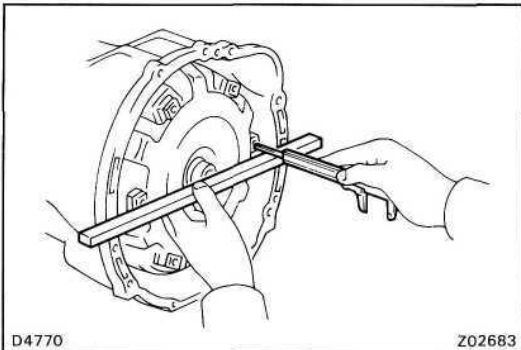

D4770

Z02683

TRANSMISSION INSTALLATION

1. INSTALL TORQUE CONVERTER IN TRANSMISSION

If the torque converter clutch has been drained and washed, refill with new ATF.

Fluid type:

AFT DEXR0N®n

2. CHECK TORQUE CONVERTER INSTALLATION

Using calipers and a straight edge, measure from the installed surface to the front surface of the transmission.

Correct distance:

(1FZ-FE)

More than 37.2 mm (1.465 in.)

(1HD-T)

More than 43.8 mm (1.724 in.)

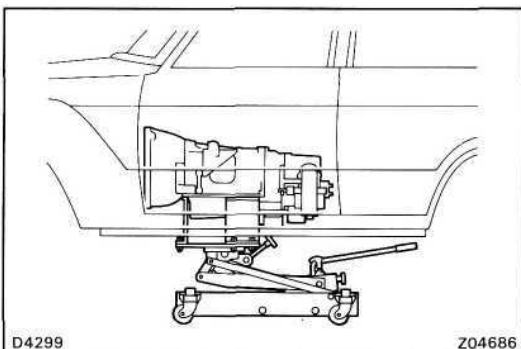

D4299

Z04686

3. PLACE TRANSMISSION AT INSTALLATION POSITION

Jack up and push the transmission fully into position.

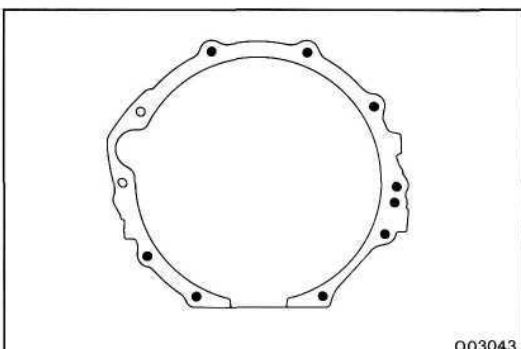

Q03043

4. INSTALL TRANSMISSION BOLTS

- (a) Install the transmission with the bolts.

Torque: 72 N·m (730 kgfcm, 53 ft·lbf)

- (b) Connect the wire harness to the transmission and transfer with the clamp.
- (c) Connect the connectors to the transfer.

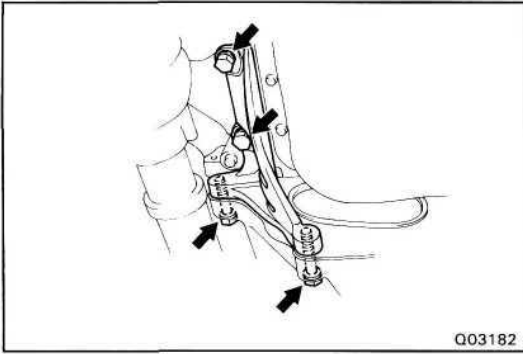

- (d) (1HD-T)
Install the left and right stiffener plates with the eight bolt.

Torque: 37 Nm (380 kgf-cm, 27 ft-lbf)

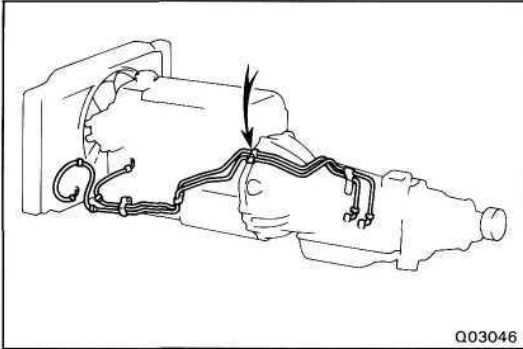

- (e) Connect the oil cooler tube clamp to the converter housing with the bolt.

- (f) Connect the park/neutral position switch.

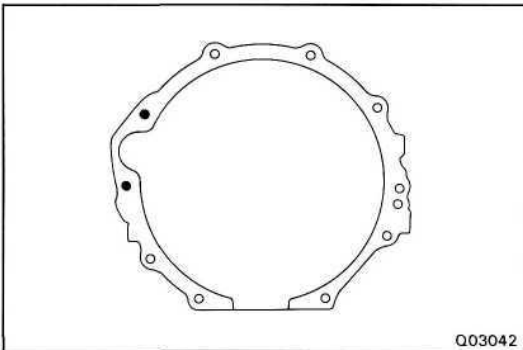

- (g) (1FZ-FE)
Install the starter with the two bolts.

Torque: 72 Nm (730 kgf-cm, 53 ft-lbf)

- (h) (1FZ-FE)
Connect the connectors.

- (i) Install the nut.

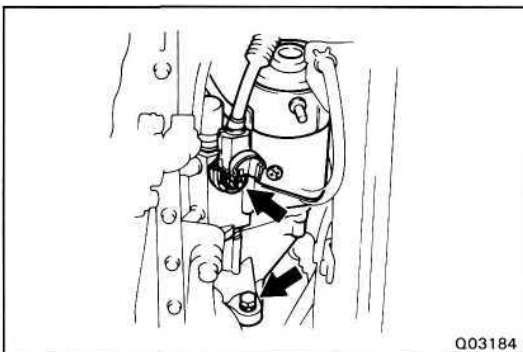

- (j) (1HD-T)
Install the starter with the bolt.

Torque: 72 N-m (730 kgf-cm, 53 ft-lbf)

- (k) (1HD-T)
Connect the connectors.

- (l) (1HD-T)
Install the nut.

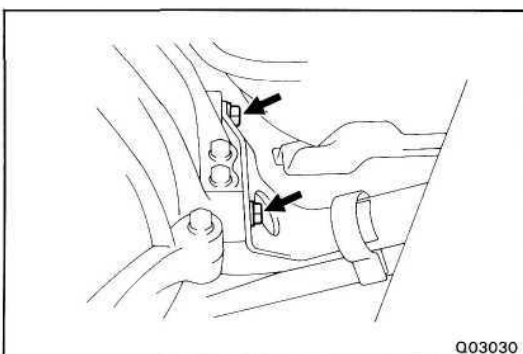

- (m) Connect the exhaust pipe bracket to the converter housing with the two bolts.

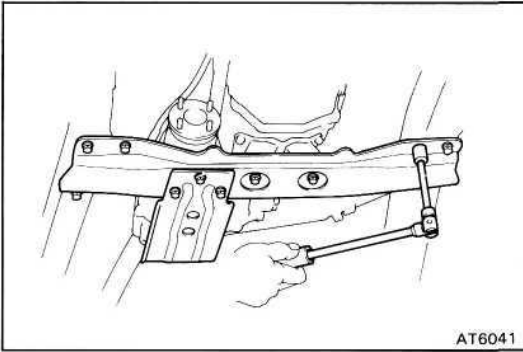

5. INSTAL CROSSMEMBER

Install the crossmember with eight bolts and two nuts.

Torque: 61 N-m (620 kgf-cm, 45 ft-lbf)

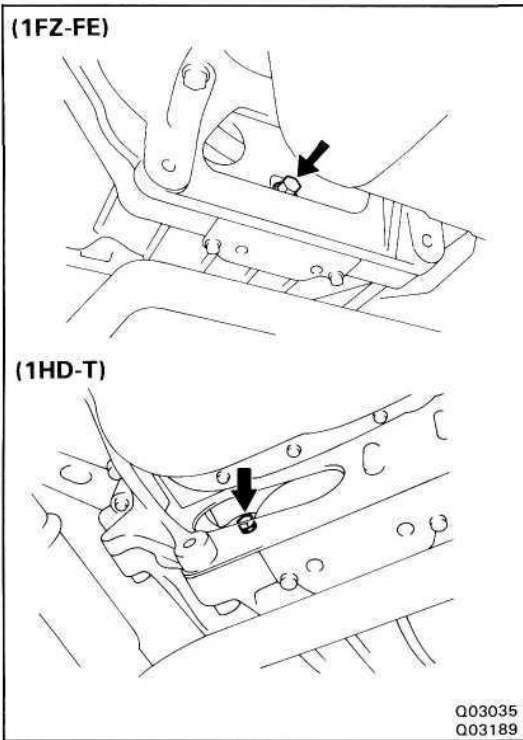

6. INSTALL TORQUE CONVERTER MOUNTING BOLTS

(a) Install the six bolts while turning the crankshaft.

Torque: 55 N-m (550 kgf-cm, 40 ft-lbf)

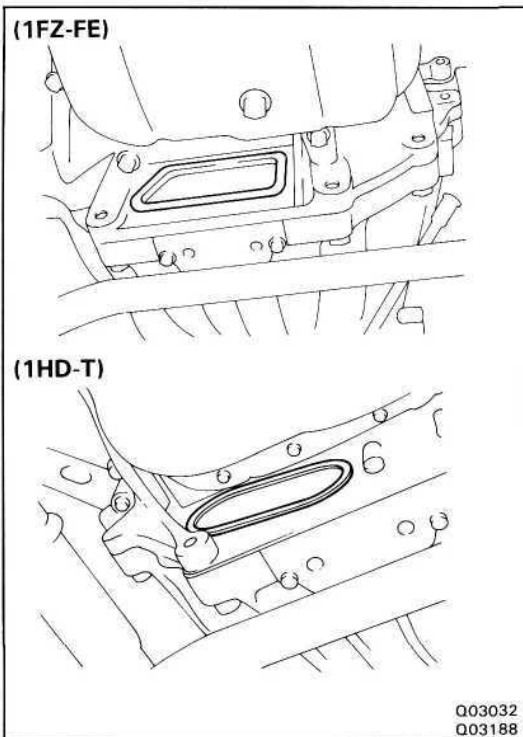

(b) Seal the converter hole plug with adhesive.

(c) Install the converter hole plug.

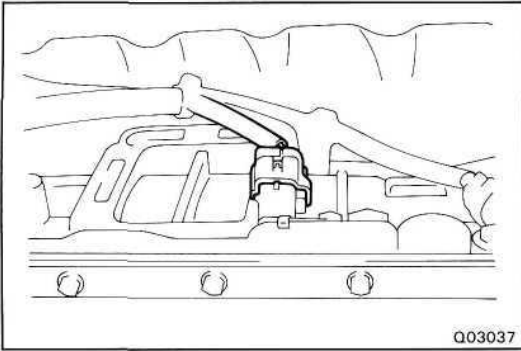

7. CONNECT SOLENOID CONNECTOR

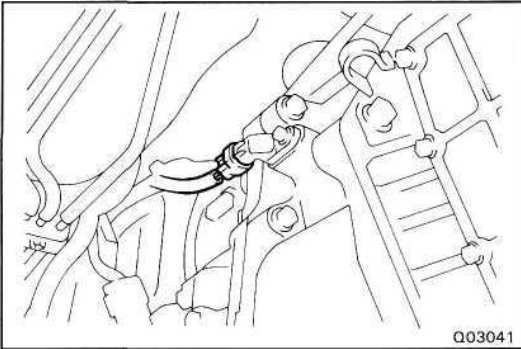

8. CONNECT NO.2 SPEED SENSOR CONNECTOR

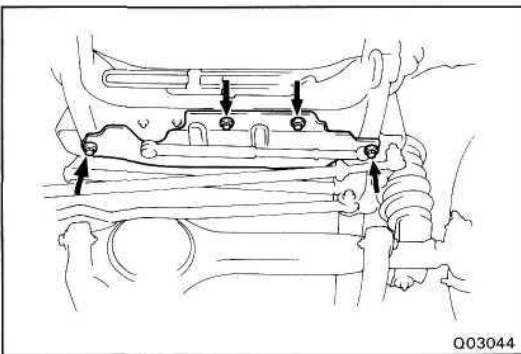

9. INSTALL ENGINE UNDER COVER

Install the cover with the four bolts.

Torque: 28 Nm (290 kgf-cm, 21 ft-lbf)

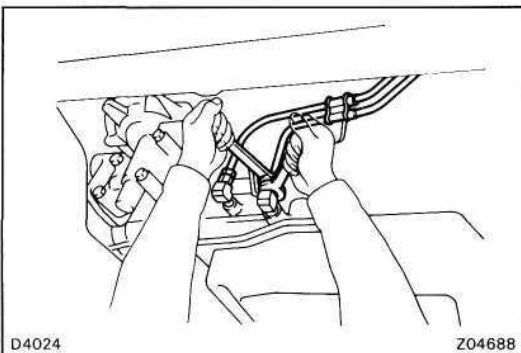

10. CONNECT TWO OIL COOLER TUBES

(a) Connect the two oil cooler tubes.

Torque: 34 Nm (350 kgf-cm, 25 ft-lbf)

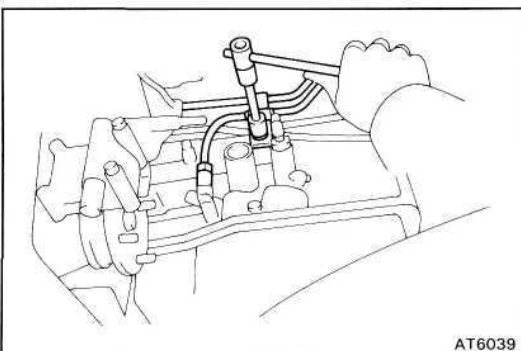

(b) Install the cooler tube clamp.

Torque: 10 Nm (100 kgf-cm, 7 ft-lbf)

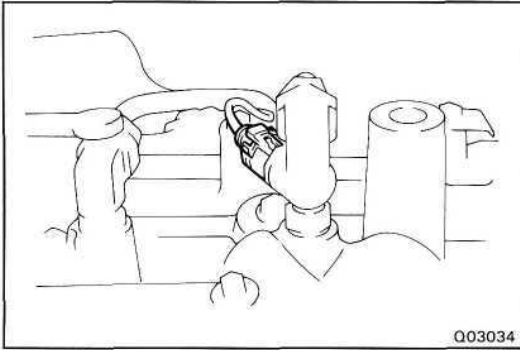

- (c) Connect the oil temperature sensor connector.

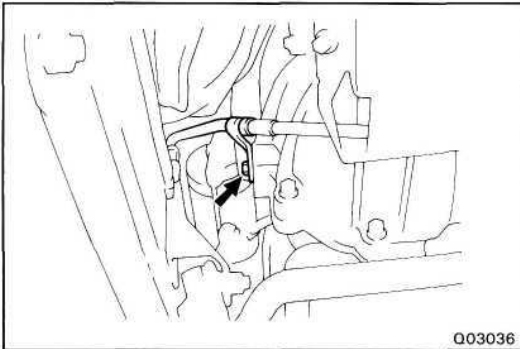

11. REMOVE OIL FILLER TUBE

- (a) Install the filler tubes with the bolt.

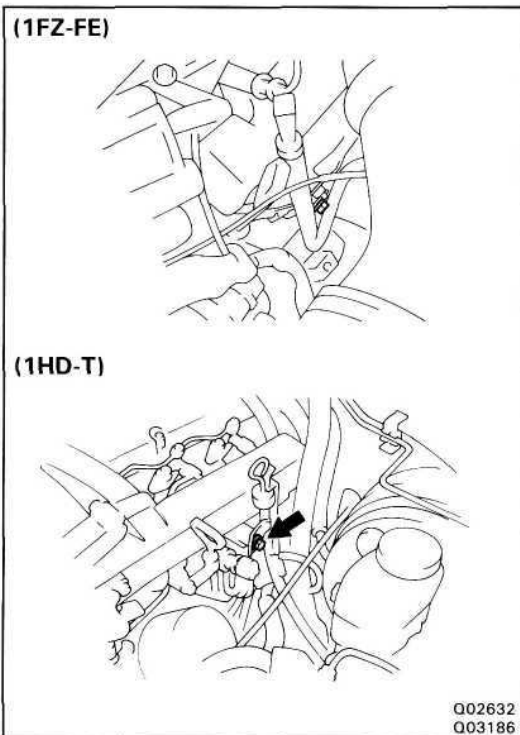

- (b) Install the bolt.
(c) Install the level gauge.

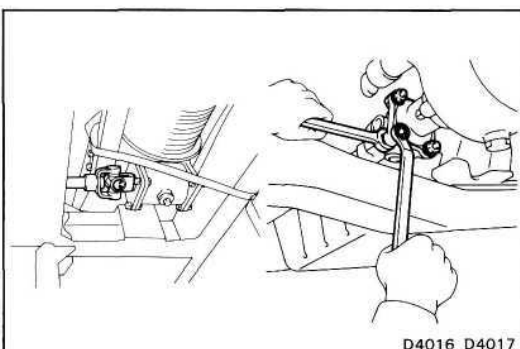

**12. (w/ MECHANICAL WINCH)
INSTALL POWER TAKE-OFF DRIVE SHAFT**

- (a) Align the matchmarks on the joint flange yoke and drive shaft.
(b) Install the drive shaft.
(c) Align the matchmarks on the drive shaft and PTO.
(d) Torque the nuts.

Torque: 20 Nm (200 kgfcm, 14 ft-lbf)

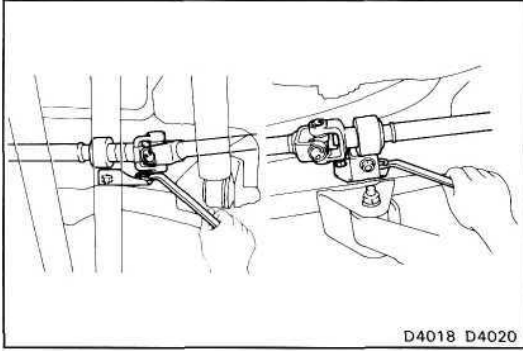

- (e) Install the front and rear bracket.

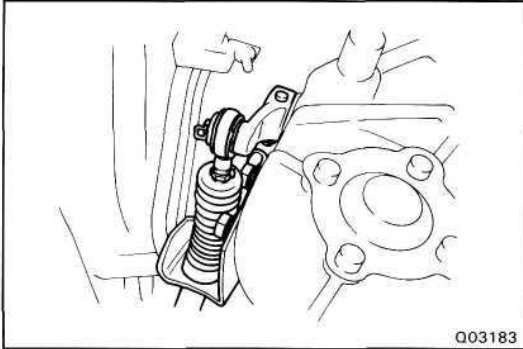

**13. (w/MECHANICAL WINCH)
INSTALL POWER TAKE-OFF SHIFT CABLE**

- (a) Install the two bolts and the cable bracket.
(b) Connect the cable and insert the pin.

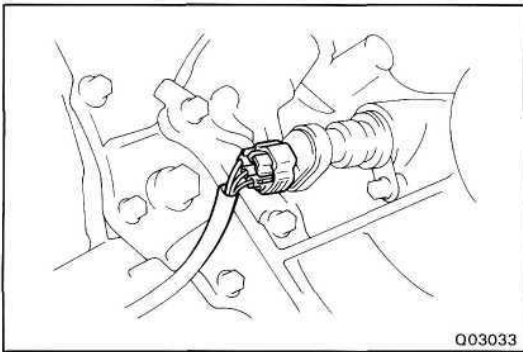

14. CONNECT NO.1 SPEED SENSOR CONNECTOR

**15. INSTALL FRONT AND REAR PROPELLER SHAFTS
(See Pub. No. RM184E, page PR-8)**

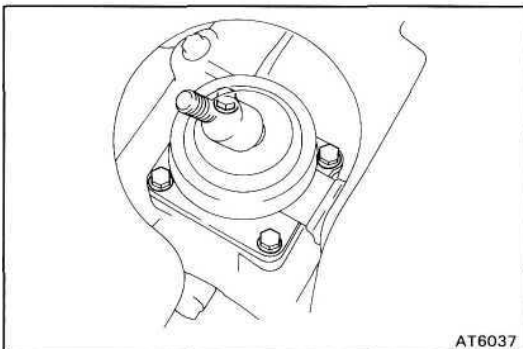

16. INSTALL TRANSMISSION SELECT LEVER AND TRANSFER SHIFT LEVER

- (a) Remove the four bolts and the transfer shift lever.

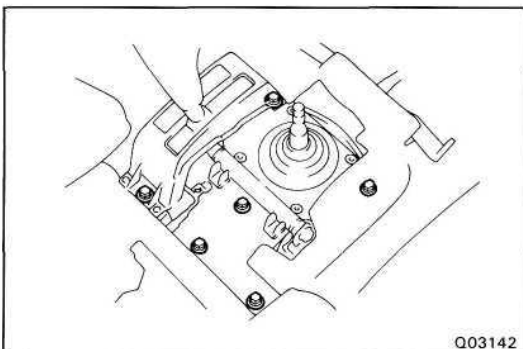

- (b) Install the transmission shift lever assembly with the six bolts.

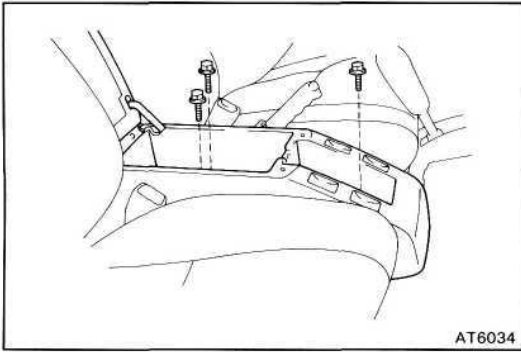

(c) Install the console box with the three bolts.

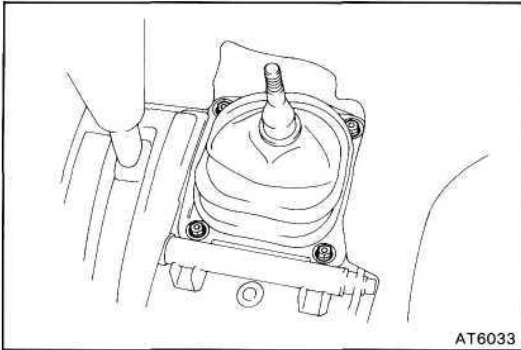

(d) Install the transfer shift lever boot with the four bolts.

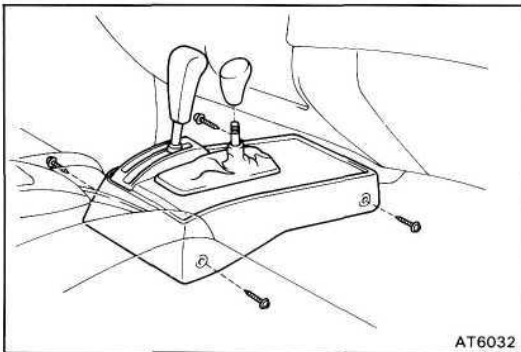

(e) Install the four screws and the console.

(f) Install the transfer shift lever knob.

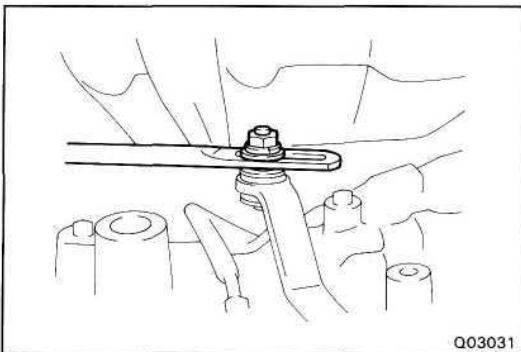

(g) Connect the link with the washer and nut.

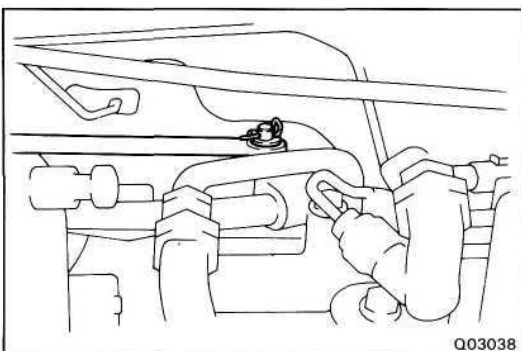

(h) Connect the link with the wave washer, washer and clip.

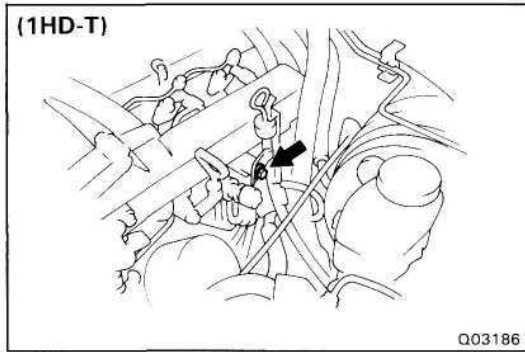

17. (1HD-T)
INSTALL STARTER MOUNT BOLT

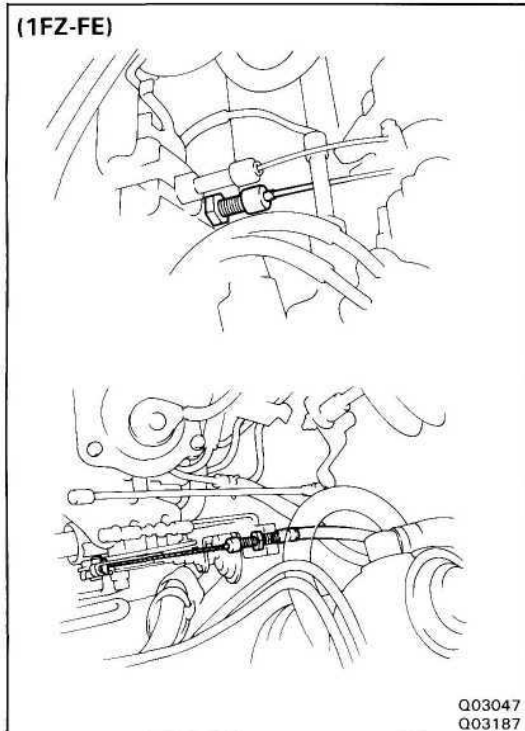

18. CONNECT THROTTLE CABLE
- Connect the cable from the throttle linkage.
 - Tighten the adjusting nuts and connect the cable housing to the bracket.

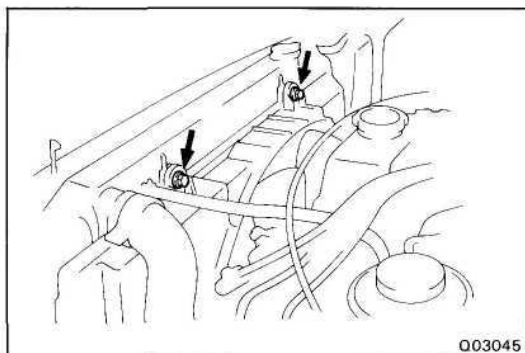

19. TIGHTEN FAN SHROUD OF COOLING FAN TO AVOID
DAMAGE TO FAN

20. INSTALL BATTERY AND COVER

21. CONNECT BATTERY CABLE FROM NEGATIVE TERMINAL

22. ADJUST SHIFT CONTROL ROD
(See page AT-26)

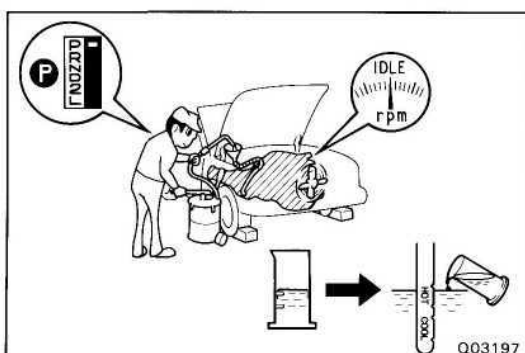

23. FILL SHIFT CONTROL ROD

Fluid type:
ATF DEXRON®H

Capacity:
6.0 liters (6.3 US qts, 5.3 Imp.qts)

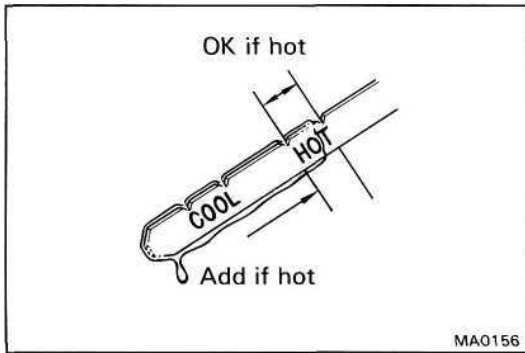

24. CHECK FLUID LEVEL
(See page AT-25)

TORQUE SPECIFICATION

Part tightened	N·m	kgf·cm	ft·lbf
Engine × Transmission 14 mm (0.55 in.) head bolt	37	380	27
Engine × Transmission 17 mm (0.67 in.) head bolt	72	730	53
Torque converter × Drive plate	55	550	40
Frame crossmember set bolt	61	620	45
Frame crossmember set nut	59	600	43
Oil cooler pipe union nut	34	350	25
Oil cooler pipe tube clamp × Transmission	10	100	7
Front differentail × Front propeller shaft	74	750	54
Transfer × Front propeller shaft	74	750	54
Transfer × Rear propeller shaft	88	900	65
Rear differentail × Rear propeller shaft	88	900	65
Crank shaft × Drive plate	100	1,000	72
Engine under cover × Frame	28	290	21
Transfer shift lever × Transmission	18	185	13
Oil pan set bolt	6.9	70	61 in.·lbf
Drain plug	27	280	20
Vaive body × Transmission case	10	100	7
Transfer under cover × Frame	28	290	21