

HOW TO USE THIS MANUAL

GENERAL INFORMATION

IN01F-04

1. INDEX

An INDEX is provided on the first page of each section to guide you to the item to be repaired. To assist you in finding your way through the manual, the Section Title and major heading are given at the top of every page.

2. GENERAL DESCRIPTION

At the beginning of each section, a General Description is given that pertains to all repair operations contained in that section.

Read these precautions before starting any repair task.

3. TROUBLESHOOTING

TROUBLESHOOTING tables are included for each system to help you diagnose the problem and find the cause. The fundamentals of how to proceed with troubleshooting are described on [page IN-8](#).

Be sure to read this before performing troubleshooting.

4. PREPARATION

Preparation lists the SST (Special Service Tools), recommended tools, equipment, lubricant and SSM (Special Service Materials) which should be prepared before beginning the operation and explains the purpose of each one.

5. REPAIR PROCEDURES

Most repair operations begin with an overview illustration. It identifies the components and shows how the parts fit together.

Example:

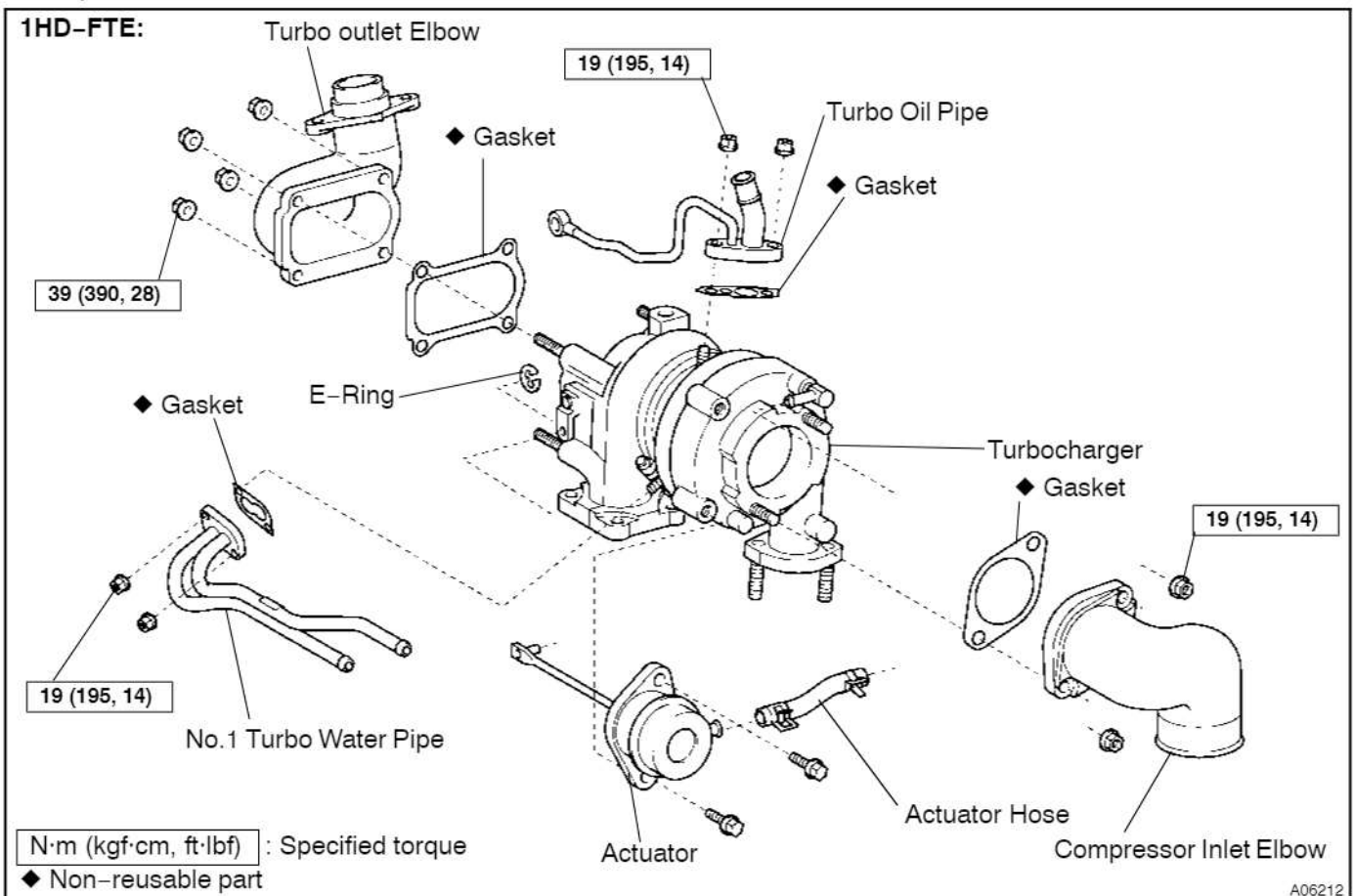

The procedures are presented in a step-by-step format:

- The illustration shows what to do and where to do it.
- The task heading tells what to do.
- The detailed text tells how to perform the task and gives other information such as specifications and warnings.

Example:

*Illustration:
what to do and where*

Task heading: what to do

21. CHECK PISTON STROKE OF OVERDRIVE BRAKE

(a) Place SST and a dial indicator onto the overdrive brake Piston as shown in the illustration.

SST 09350-30020 (09350-06120)

Set part No. *Component part No.*

Detailed text: how to do task

(b) Measure the stroke applying and releasing the compressed air (392 — 785 kPa, 4 — 8 kgf/cm² or 57 — 114 psi) as shown in the illustration.

Piston stroke: 1.40 — 1.70 mm (0.0551 — 0.0669 in.)

Specification

This format provides the experienced technician with a FAST TRACK to the information needed. The upper case task heading can be read at a glance when necessary, and the text below it provides detailed information. Important specifications and warnings always stand out in bold type.

6. REFERENCES

References have been kept to a minimum. However, when they are required you are given the page to refer to.

7. SPECIFICATIONS

Specifications are presented in bold type throughout the text where needed. You never have to leave the procedure to look up your specifications. They are also found in Service Specifications section for quick reference.

8. CAUTIONS, NOTICES, HINTS:

- CAUTIONS are presented in bold type, and indicate there is a possibility of injury to you or other people.
- NOTICES are also presented in bold type, and indicate the possibility of damage to the components being repaired.
- HINTS are separated from the text but do not appear in bold. They provide additional information to help you perform the repair efficiently.

9. SI UNIT

The UNITS given in this manual are primarily expressed according to the SI UNIT (International System of Unit), and alternately expressed in the metric system and in the English System.

Example:

Torque: 30 N·m (310 kgf·cm, 22 ft·lbf)

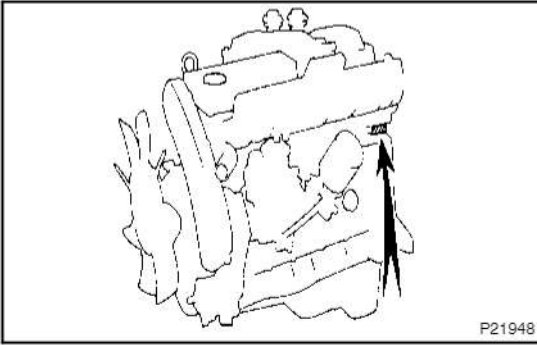

IDENTIFICATION INFORMATION

ENGINE SERIAL NUMBER

IN01G-04

The engine serial number is stamped on the engine block as shown.

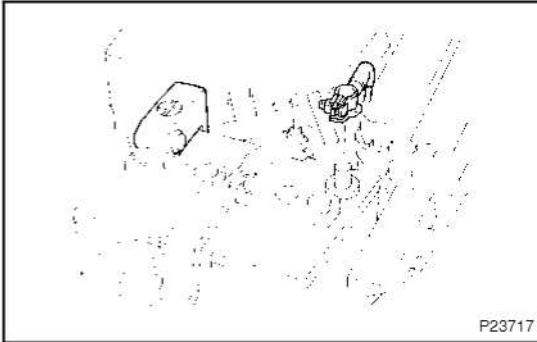

REPAIR INSTRUCTIONS

GENERAL INFORMATION

IN01H-04

BASIC REPAIR HINT

- (a) Use fender, seat and floor covers to keep the vehicle clean and prevent damage.
- (b) During disassembly, keep parts in the appropriate order to facilitate reassembly.
- (c) Observe the following:
 - (1) Before performing electrical work, disconnect the negative (-) terminal cable from the battery.
 - (2) If it is necessary to disconnect the battery for inspection or repair, always disconnect the negative (-) terminal cable which is grounded to the vehicle body.
 - (3) To prevent damage to the battery terminal, loosen the cable nut and raise the cable straight up without twisting or prying it.
 - (4) Clean the battery terminals and cable ends with a clean shop rag. Do not scrape them with a file or other abrasive objects.
 - (5) Install the cable ends to the battery terminals with the nut loose, and tighten the nut after installation. Do not use a hammer to tap the cable ends onto the terminals.
 - (6) Be sure the cover for the positive (+) terminal is properly in place.
- (d) Check hose and wiring connectors to make sure that they are secure and correct.
- (e) Non-reusable parts
 - (1) Always replace cotter pins, gaskets, O-rings and oil seals etc. with new ones.
 - (2) Non-reusable parts are indicated in the component illustrations by the "◆" symbol.
- (f) Precoated parts







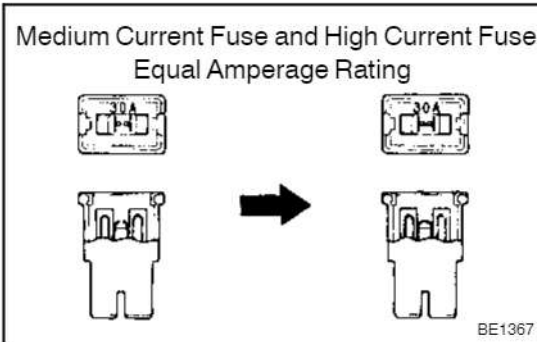

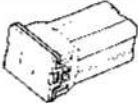

Precoated parts are bolts and nuts, etc. that are coated with a seal lock adhesive at the factory.

 - (1) If a precoated part is retightened, loosened or caused to move in any way, it must be recoated with the specified adhesive.
 - (2) When reusing precoated parts, clean off the old adhesive and dry with compressed air. Then apply the specified seal lock adhesive to the bolt, nut or threads.
 - (3) Precoated parts are indicated in the component illustrations by the "★" symbol.
- (g) When necessary, use a sealer on gaskets to prevent leaks.

- (h) Carefully observe all specifications for bolt tightening torques. Always use a torque wrench.
- (i) Use of special service tools (SST) and special service materials (SSM) may be required, depending on the nature of the repair. Be sure to use SST and SSM where specified and follow the proper work procedure. A list of SST and SSM can be found in section PP (Preparation) in this manual.



- (j) When replacing fuses, be sure the new fuse has the correct amperage rating. DO NOT exceed the rating or use one with a lower rating.

Illustration	Symbol	Part Name	Abbreviation
 BE5594	 IN0365	FUSE	FUSE
 BE5595	 IN0366	MEDIUM CURRENT FUSE	M-FUSE
 BE5596	 IN0367	HIGH CURRENT FUSE	H-FUSE
 BE5597	 IN0367	FUSIBLE LINK	FL
 BE5598	 IN0368	CIRCUIT BREAKER	CB

V00076

- (k) Care must be taken when jacking up and supporting the vehicle. Be sure to lift and support the vehicle at the proper locations.
 - (1) If the vehicle is to be jacked up only at the front or rear end, be sure to block the wheels at the opposite end in order to ensure safety.
 - (2) After the vehicle is jacked up, be sure to support it on stands. It is extremely dangerous to do any work on a vehicle raised on a jack alone, even for a small job that can be finished quickly.

- (l) Observe the following precautions to avoid damage to the following parts:

- (1) Do not open the cover or case of the ECU unless absolutely necessary. (If the IC terminals are touched, the IC may be destroyed by static electricity.)

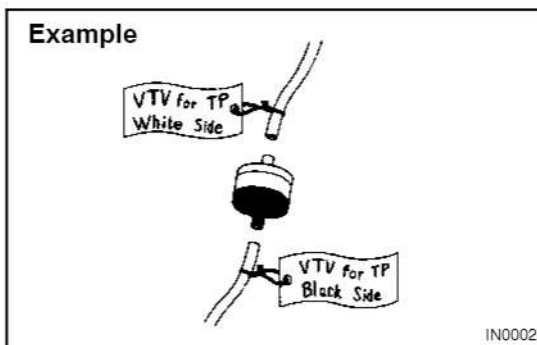
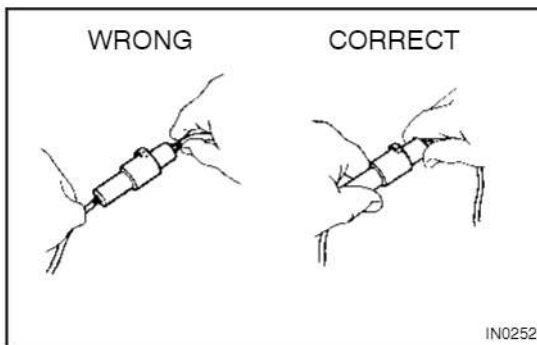
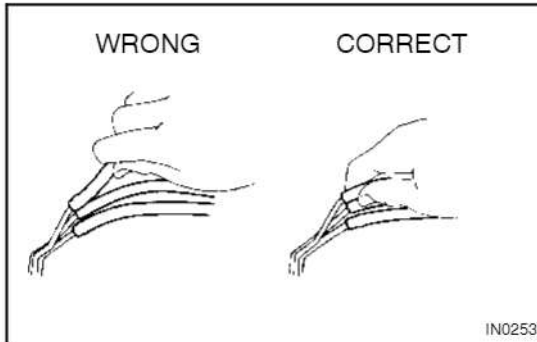

- (2) To disconnect vacuum hoses, pull on the end, not the middle of the hose.
- (3) To pull apart electrical connectors, pull on the connector itself, not the wires.
- (4) Be careful not to drop electrical components, such as sensors or relays. If they are dropped on a hard floor, they should be replaced and not reused.
- (5) When steam cleaning an engine, protect the electronic components, air filter and emissions-related components from water.
- (6) Never use an impact wrench to remove or install temperature switches or temperature sensors.
- (7) When checking continuity at the wire connector, insert the tester probe carefully to prevent terminals from bending.
- (8) When using a vacuum gauge, never force the hose onto a connector that is too large. Use a step-down adapter instead. Once the hose has been stretched, it may leak.

- (m) Tag hoses before disconnecting them:
- (1) When disconnecting vacuum hoses, use tags to identify how they should be reconnected.
- (2) After completing a job, double check that the vacuum hoses are properly connected. A label under the hood shows the proper layout.
- (n) Unless otherwise stated, all resistance is measured at an ambient temperature of 20°C (68°F). Because the resistance may be outside specifications if measured at high temperatures immediately after the vehicle has been running, measurements should be made when the engine has cooled down.

FOR ALL OF VEHICLES

IN011-04

PRECAUTION

1. IF VEHICLE IS EQUIPPED WITH MOBILE COMMUNICATION SYSTEM

For vehicles with mobile communication systems such as two-way radios and cellular telephones, observe the following precautions.

- (1) Install the antenna as far as possible away from the ECU and sensors of the vehicle's electronic system.
- (2) Install the antenna feeder at least 20 cm (7.87 in.) away from the ECU and sensors of the vehicle's electronics systems. For details about ECU and sensors locations, refer to the section on the applicable component.
- (3) Do not wind the antenna feeder together with the other wiring. As much as possible, also avoid running the antenna feeder parallel with other wire harnesses.
- (4) Confirm that the antenna and feeder are correctly adjusted.
- (5) Do not install powerful mobile communications system.

2. FOR USING HAND-HELD TESTER

CAUTION:

Observe the following for safety reasons:

- Before using the hand-held tester, the hand-held tester's operator manual should be read thoroughly.
- Be sure to route all cables securely when driving with the hand-held tester connected to the vehicle. (i.e. Keep cables away from feet, pedals, steering wheel and shift lever.)
- Two persons are required when test driving with the hand-held tester, one person to drive the vehicle and one person to operate the hand-held tester.

HOW TO TROUBLESHOOT ECU CONTROLLED SYSTEMS

IN01J-07

GENERAL INFORMATION

A large number of ECU controlled systems are used in the LAND CRUISER. In general, the ECU controlled system is considered to be a very intricate system requiring a high level of technical knowledge and expert skill to troubleshoot. However, the fact is that if you proceed to inspect the circuits one by one, troubleshooting of these systems is not complex. If you have adequate understanding of the system and a basic knowledge of electricity, accurate diagnosis and necessary repair can be performed to locate and fix the problem. This manual is designed through emphasis of the above standpoint to help service technicians perform accurate and effective troubleshooting, and is compiled for the following major ECU controlled systems:

System	Page
Engine	DI-1

The troubleshooting procedure and how to make use of it are described on the following pages.

FOR USING HAND-HELD TESTER

- Before using the hand-held tester, the hand-held tester's operator manual should be read throughly.
- If the hand-held tester cannot communicate with ECU controlled systems when you have connected the cable of the hand-held tester to DLC3, turned the ignition switch ON and operated the scan tool, there is a problem on the vehicle side or tool side.
 - (1) If communication is normal when the tool is connected to another vehicle, inspect the diagnosis data link line (Bus ⊕ line) or ECU power circuit of the vehicle.
 - (2) If communication is still not possible when the tool is connected to another vehicle, the problem is probably in the tool itself, so perform the Self Test procedures outlined in the Tester Operator's Manual.

HOW TO PROCEED WITH TROUBLESHOOTING

Carry out troubleshooting in accordance with the procedure on the following page. Here, only the basic procedure is shown. Details are provided in each section, showing the most effective methods for each circuit. Confirm the troubleshooting procedures first for the relevant circuit before beginning troubleshooting of that circuit.

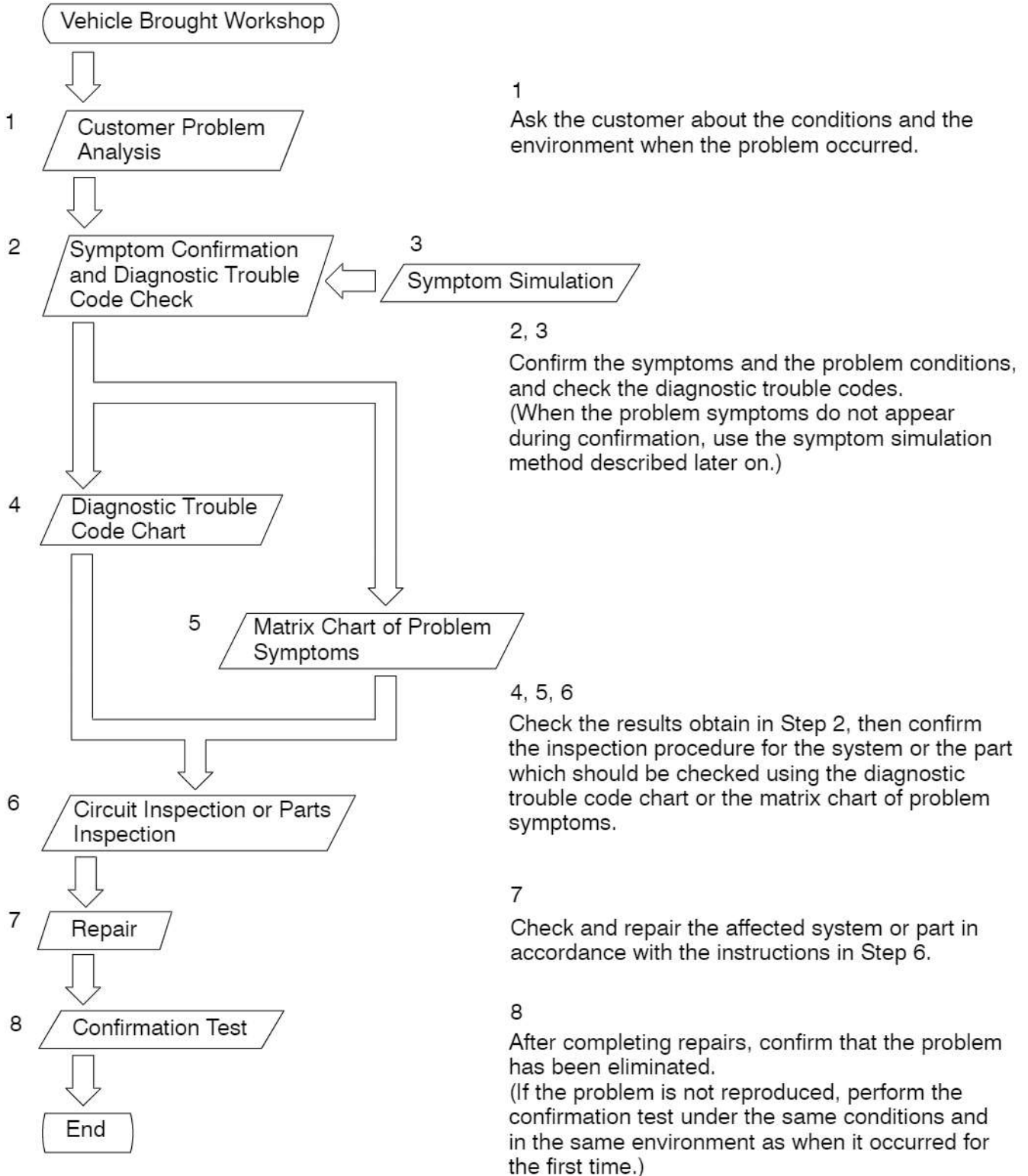

1. CUSTOMER PROBLEM ANALYSIS

In troubleshooting, the problem symptoms must be confirmed accurately and all preconceptions must be cleared away in order to give an accurate judgment. To ascertain just what the problem symptoms are, it is extremely important to ask the customer about the problem and the conditions at the time it occurred.

Important Point in the Problem Analysis:

The following 5 items are important points in the problem analysis. Past problems which are thought to be unrelated and the repair history, etc. may also help in some cases, so as much information as possible should be gathered and its relationship with the problem symptoms should be correctly ascertained for reference in troubleshooting. A customer problem analysis table is provided in the troubleshooting section for each system for your use.

Important Points in the Customer Problem Analysis

- What ----- Vehicle model, system name
- When ----- Date, time, occurrence frequency
- Where ----- Road conditions
- Under what conditions? ----- Running conditions, driving conditions, weather conditions
- How did it happen? ----- Problem symptoms

(Sample) Engine control system check sheet.

CUSTOMER PROBLEM ANALYSIS CHECK					
ENGINE CONTROL SYSTEM Check Sheet		Inspector's Name _____			
Customer's Name		Model and Model Year			
Driver's Name		Frame No.			
Data Vehicle Brought in		Engine Model			
License No.		Odometer Reading	km miles		
Problem Symptoms	<input type="checkbox"/> Engine does not Start	<input type="checkbox"/> Engine does not crank	<input type="checkbox"/> No initial combustion	<input type="checkbox"/> No complete combustion	
	<input type="checkbox"/> Difficult to Start	<input type="checkbox"/> Engine cranks slowly <input type="checkbox"/> Other _____			
	<input type="checkbox"/> Poor Idling	<input type="checkbox"/> Incorrect first idle	<input type="checkbox"/> Idling rpm is abnormal	<input type="checkbox"/> High (rpm)	<input type="checkbox"/> Low (rpm)
	<input type="checkbox"/> Poor Drive ability	<input type="checkbox"/> Hesitation	<input type="checkbox"/> Back fire	<input type="checkbox"/> Muffler explosion (after-fire)	<input type="checkbox"/> Surging
	<input type="checkbox"/> Engine Stall	<input type="checkbox"/> Knocking <input type="checkbox"/> Other _____			
	<input type="checkbox"/> Engine Stall	<input type="checkbox"/> Soon after starting <input type="checkbox"/> After accelerator pedal depressed <input type="checkbox"/> After accelerator pedal released <input type="checkbox"/> During A/C operation <input type="checkbox"/> Shifting from N to D <input type="checkbox"/> Other _____			
<input type="checkbox"/> Others	_____				
<input type="checkbox"/> constant <input type="checkbox"/> Sometimes (times per day/month)					

2. SYMPTOM CONFIRMATION AND DIAGNOSTIC TROUBLE CODE CHECK

The diagnostic system in the LAND CRUISER fulfills various functions. The first function is the Diagnostic Trouble Code Check in which a malfunction in the signal circuits to the ECU is stored in code in the ECU memory at the time of occurrence, to be output by the technician during troubleshooting. Another function is the Input Signal Check which checks if the signals from various switches are sent to the ECU correctly. By using these check functions, the problem areas can be narrowed down quickly and troubleshooting can be performed effectively. Diagnostic functions are incorporated in the following systems in the LAND CRUISER.

System	Diagnostic Trouble Code Check	Input Signal Check (Sensor Check)	Other Diagnosis Function
Engine	○ (with Check Mode)	○	Diagnostic Test Mode

In diagnostic trouble code check, it is very important to determine whether the problem indicated by the diagnostic trouble code is still occurring or occurred in the past but returned to normal at present. In addition, it must be checked in the problem symptom check whether the malfunction indicated by the diagnostic trouble code is directly related to the problem symptom or not. For this reason, the diagnostic trouble codes should be checked before and after the symptom confirmation to determine the current conditions, as shown in the table below. If this is not done, it may, depending on the case, result in unnecessary troubleshooting for normally operating systems, thus making it more difficult to locate the problem, or in repairs not pertinent to the problem. Therefore, always follow the procedure in correct order and perform the diagnostic trouble code check.

DIAGNOSTIC TROUBLE CODE CHECK PROCEDURE

Diagnostic Trouble Code Check (Make a note of and then clear)	Confirmation of Symptoms	Diagnostic Trouble Code Check	Problem Condition
Diagnostic Trouble Code Display	Problem symptoms exist	Same diagnostic trouble code is displayed	Problem is still occurring in the diagnostic circuit
	⇒	Normal code is displayed	The problem is still occurring in a place other than in the diagnostic circuit. (The diagnostic trouble code displayed first is either for a past problem or it is a secondary problem.)
		No problem symptoms exist	
Normal Code Display	Problem symptoms exist	Normal code is displayed	The problem is still occurring in a place other than in the diagnostic circuit.
	No problem symptoms exist	Normal code is displayed	The problem occurred in a place other than in the diagnostic circuit in the past.

Taking into account the above points, a flow chart showing how to proceed with troubleshooting using the diagnostic trouble code check is shown below. This flow chart shows how to utilize the diagnostic trouble code check effectively, then by carefully checking the results, indicates how to proceed either to diagnostic trouble code troubleshooting or to troubleshooting of problem symptoms.

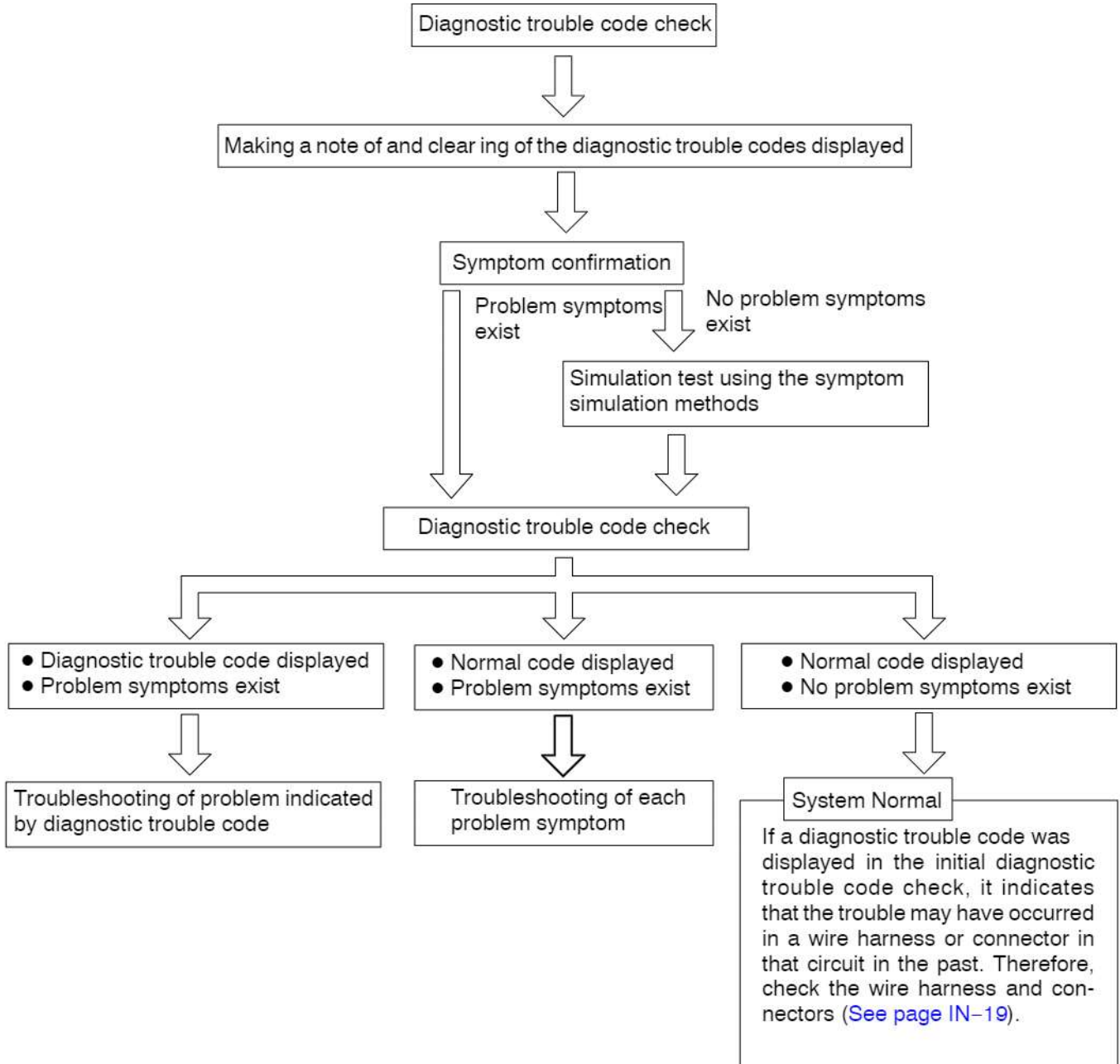

cardiagn.com



3. SYMPTOM SIMULATION

The most difficult case in troubleshooting is when there are no problem symptoms occurring. In such cases, a thorough customer problem analysis must be carried out, then simulate the same or similar conditions and environment in which the problem occurred in the customer's vehicle. No matter how much experience a technician has, or how skilled he may be, if he proceeds to troubleshoot without confirming the problem symptoms he will tend to overlook something important in the repair operation and make a wrong guess somewhere, which will only lead to a standstill. For example, for a problem which only occurs when the engine is cold, or for a problem which occurs due to vibration caused by the road during driving, etc., the problem can never be determined so long as the symptoms are confirmed with the engine hot condition or the vehicle at a standstill. Since vibration, heat or water penetration (moisture) are likely causes for problems which are difficult to reproduce, the symptom simulation tests introduced here are effective measures in that the external causes are applied to the vehicle in a stopped condition.

Important Points in the Symptom Simulation Test:

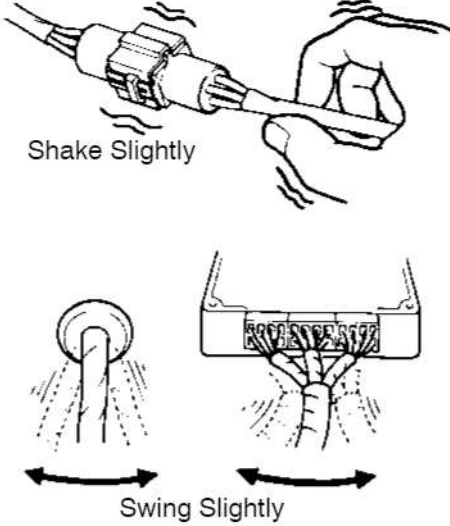
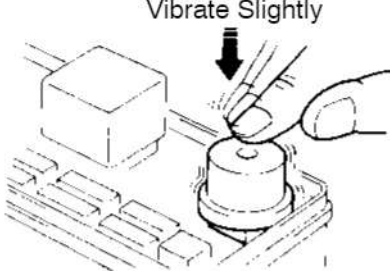
In the symptom simulation test, the problem symptoms should of course be confirmed, but the problem area or parts must also be found out. To do this, narrow down the possible problem circuits according to the symptoms before starting this test and connect a tester beforehand. After that, carry out the symptom simulation test, judging whether the circuit being tested is defective or normal and also confirming the problem symptoms at the same time. Refer to the matrix chart of problem symptoms for each system to narrow down the possible causes of the symptom.

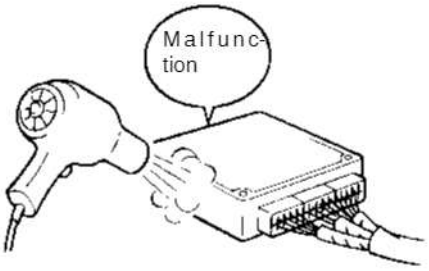
<p>1</p>	<p>VIBRATION METHOD: When vibration seems to be the major cause.</p>
<p>CONNECTORS Slightly shake the connector vertically and horizontally.</p> <p>WIRE HARNESS Slightly shake the wire harness vertically and horizontally. The connector joint, fulcrum of the vibration, and body through portion are the major areas to be checked thoroughly.</p>	 <p>The diagrams illustrate two vibration methods. The top diagram shows a hand holding a connector with the text 'Shake Slightly' and wavy lines indicating movement. The bottom diagram shows a hand holding a wire harness with the text 'Swing Slightly' and arrows indicating a swinging motion.</p>
<p>PARTS AND SENSOR Apply slight vibration with a finger to the part of the sensor considered to be the problem cause and check if the malfunction occurs.</p> <p>HINT: Applying strong vibration to relays may result in open relays.</p>	 <p>The diagram shows a hand applying vibration to a sensor on a circuit board with the text 'Vibrate Slightly' and a downward arrow.</p>

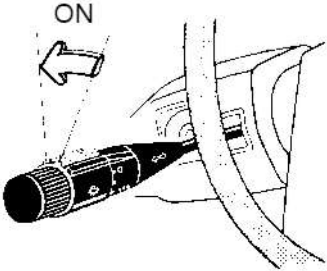
<p>2</p>	<p>HEAT METHOD: When the problem seems to occur when the suspect area is heated.</p>
<p>Heat the component that is the likely cause of the malfunction with a hair dryer or similar object. Check to see if the malfunction occurs.</p> <p>NOTICE: (1) Do not heat to more than 60 °C (140 °F). (Temperature limit that no damage is done to the component.) (2) Do not apply heat directly to parts in the ECU.</p>	 <p>F12334</p>
<p>3</p>	<p>WATER SPRINKLING METHOD: When the malfunction seems to occur on a rainy day or in a high-humidity condition.</p>
<p>Sprinkle water onto the vehicle and check to see if the malfunction occurs.</p> <p>NOTICE: (1) Never sprinkle water directly into the engine compartment, but indirectly change the temperature and humidity by applying water spray onto the radiator front surface. (2) Never apply water directly onto the electronic components.</p> <p>(Service hint) If a vehicle is subject to water leakage, the leaked water may contaminate the ECU. When testing a vehicle with a water leakage problem, special caution must be used.</p>	 <p>F16649</p>
<p>4</p>	<p>OTHER: When a malfunction seems to occur when electrical load is excessive.</p>
<p>Turn on all electrical loads including the heater blower, head lights, rear window defogger, etc. and check to see if the malfunction occurs.</p>	 <p>F12336</p>

cardiagn.com

4. DIAGNOSTIC TROUBLE CODE CHART

The inspection procedure is shown in the table below. This table permits efficient and accurate troubleshooting using the diagnostic trouble codes displayed in the diagnostic trouble code check. Proceed with troubleshooting in accordance with the inspection procedure given in the diagnostic chart corresponding to the diagnostic trouble codes displayed. The engine diagnostic trouble code chart is shown below as an example.

● **DTC No.**
Indicates the diagnostic trouble code.

● **Page or Instructions**
Indicates the page where the inspection procedure for each circuit is to be found, or gives instructions for checking and repairs.

● **Trouble Area**
Indicates the suspect area of the problem.

● **Detection Item**
Indicates the system of the problem or contents of the problem.

DTC CHART (SAE Controlled)

HINT: Parameters listed in the chart may not be exactly the same as your reading due to the type of instrument or other factors.

If a malfunction code is displayed during the DTC check in check mode, check the circuit for that code listed in the table below. For details of each code, turn to the page referred to under the "See page" for the respective "DTC No." in the DTC chart.

DTC No. (See page)	Detection Item	Trouble Area	*1 Check Engine Warning Light Normal Mode/ Test Mode	*Memory
12 (DI-25)	Crankshaft Position Sensor Circuit Malfunction	<ul style="list-style-type: none"> ● Open or short in crankshaft position sensor circuit ● Crankshaft position sensor ● Engine ECU 	ON / N.A	○
13 (DI-30)	Engine Speed Sensor Circuit Malfunction	<ul style="list-style-type: none"> ● Open or short in engine speed sensor circuit ● Engine speed sensor ● Open or short in STA circuit ● Engine ECU 	ON / ON	○
14 (DI-35)	Timing Control System Malfunction	<ul style="list-style-type: none"> ● Open or short in timing control valve circuit ● Fuel filter (Clogging) ● Engine ECU 	ON / N.A	○
17	Ignition IC Malfunction	<ul style="list-style-type: none"> ● Engine ECU 	ON / N.A	○

cardiagn.com

5. PROBLEM SYMPTOMS TABLE

The suspect circuits or parts for each problem symptom are shown in the table below. Use this table to troubleshooting the problem when a "Normal" code is displayed in the diagnostic trouble code check but the problem is still occurring. Numbers in the table indicate the inspection order in which the circuits or parts should be checked.

HINT:

When the problem is not detected by the diagnostic system even though the problem symptom is present, it is considered that the problem is occurring outside the detection range of the diagnostic system, or that the problem is occurring in a system other than the diagnostic system.

● Page
Indicates the page where the flow chart for each circuit is located.

● Circuit Inspection, Inspection Order
Indicates the circuit which needs to be checked for each problem symptom. Check in the order indicated by the numbers.

● Problem Symptom

● Circuit or Part Name
Indicates the circuit or part which needs to be checked.

PROBLEM SYMPTOMS TABLE		
Symptom	Suspect Area	See page
Engine not crank (Difficult to start)	1. Starter and starter relay	-
No initial combustion (Difficult start)	1. Engine ECU power source circuit 2. Pre-heating system 3. Compression 4. Engine ECU 5. Injection Pump	DI-124 DI-127 EM-30 DI-128 FU-2
Cold engine (Difficult to start)	1. pre-heating system 2. STA signal circuit 3. Water temperature sensor 4. Injection nozzle 5. Fuel filter 6 Diesel throttle body 7. Engine ECU 8. Injection pump	DI-121 DI-127 DI-85 FU-15 FU-16 ED-5 D-175 FU-2
Hot engine (Difficult to start)	1. STA signal circuit 2. Injection pump 3. Fuel filter 4. Diesel throttle body 5. Engine ECU 6. Injection pump	AC-54 DL-124

cardiagn.com

6. CIRCUIT INSPECTION

How to read and use each page is shown below.

• Diagnostic Trouble Code No. and Detection Item

• Circuit Description
The major role and operation, etc. of the circuit and its component parts are explained.

DTC	14	Timing Control System Malfunction
------------	-----------	--

CIRCUIT DESCRIPTION
The engine ECU control the injection timing by actuating the timing control valve. The timing control valve is mounted on the injection pump and delay one by duty control of pump internal fuel pressure. The engine ECU detects the injection advance angle by TDC and NE signal.

DTC No.	Detection Item	Trouble Area
14	After engine warm up and during, actual injection timing is different from target value of engine ECU calculated for several sec.	<ul style="list-style-type: none"> • Open or short in timing control valve circuit • Fuel filter (Clogging) • Fuel (Freezing Airin) • Injection pump (Internal pressure and timing control valve) • Engine ECU

• Indicates the diagnostic trouble code, diagnostic trouble code set parameter and suspect area of the problem.

WIRING DIAGRAM

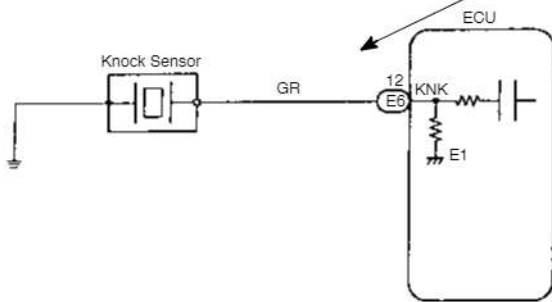

- **Wiring Diagram**
This shows a wiring diagram of the circuit. Use this diagram together with ELECTRICAL WIRING DIAGRAM to thoroughly understand the circuit.
Wire colors are indicated by an alphabetical code.
B = Black, L = Blue, R = Red, BR = Brown, LG = Light Green, V = Violet, G = Green, O = Orange, W = White, GR = Gray, P = Pink, Y = Yellow
The first letter indicates the basic wire color and the second letter indicates the color of the stripe.

cardiagn.com

- Indicates the position of the ignition switch during the check.

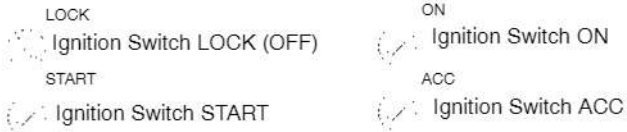

- Inspection Procedure

Use the inspection procedure to determine if the circuit is normal or abnormal, and, if it is abnormal, use it to determine whether the problem is located in the sensors, actuators, wire harness or ECU.

INSPECTION PROCEDURE

1 Check continuity between terminal KNK of ECM connector and body ground.

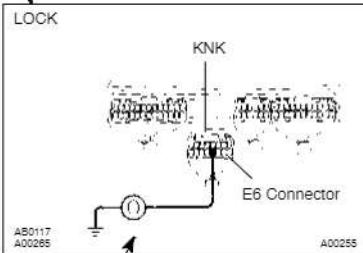

PREPARATION:

- (a) Remove the glove compartment (See page FI-37).
- (b) Disconnect the E6 connector of ECM.

CHECK:

Measure resistance between terminal KNK of ECU connector and body ground.

OK:

Resistance: 1 MΩ or higher

OK → Go to step 3.

NG

2 Check knock sensor (See page FI-34).

OK → Replace knock sensor.

- Indicates the place to check the voltage or resistance.
- Indicates the connector position to checked, from the front or back side.

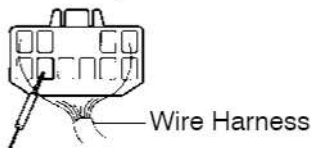

Check from the connector back side. (with harness)



Check from the connector front side. (without harness)
In this case, care must be taken not to bend the terminals.

- Indicates the condition of the connector of ECU during the check.

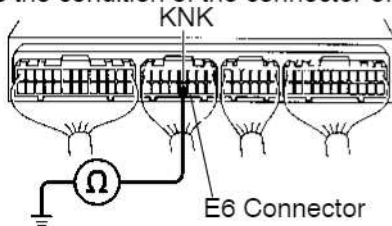

Connector being checked is connected.

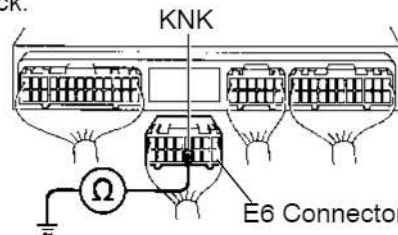

Connector being checked is disconnected.

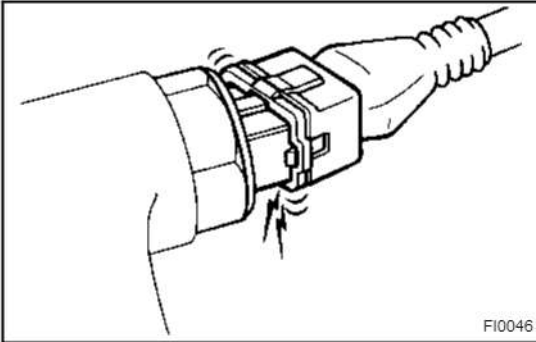

FI0046

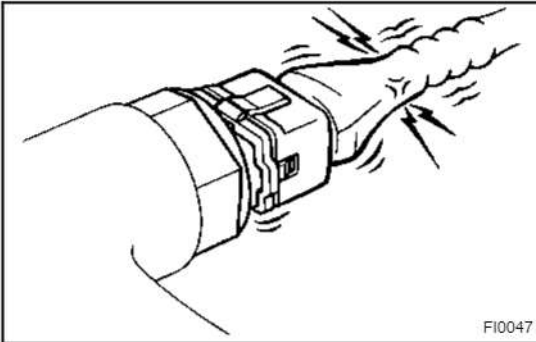

FI0047

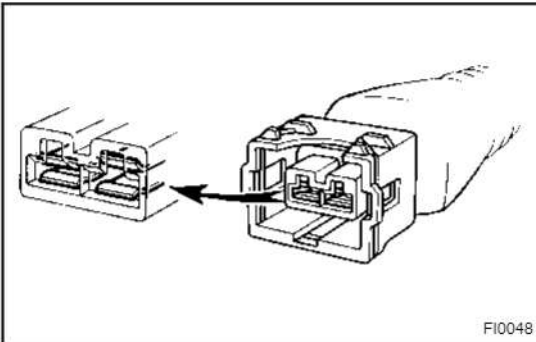

FI0048

HOW TO USE THE DIAGNOSTIC CHART AND INSPECTION PROCEDURE

1. CONNECTOR CONNECTION AND TERMINAL INSPECTION

- For troubleshooting, diagnostic trouble code charts or problem symptom charts are provided for each circuit with detailed inspection procedures on the following pages.
- When all the component parts, wire harnesses and connectors of each circuit except the ECU are found to be normal in troubleshooting, then it is determined that the problem is in the ECU. Accordingly, if diagnosis is performed without the problem symptoms occurring, the instruction will be to check and replace the ECU, even if the problem is not in the ECU. So always confirm that the problem symptoms are occurring, or proceed with inspection while using the symptom simulation method.
- The instructions "Check wire harness and connector" and "Check and replace ECU" which appear in the inspection procedure, are common and applicable to all diagnostic trouble codes. Follow the procedure outlined below whenever these instructions appear.

OPEN CIRCUIT:

This could be due to a disconnected wire harness, faulty contact in the connector, a connector terminal pulled out, etc.

HINT:

- It is rarely the case that a wire is broken in the middle of it. Most cases occur at the connector. In particular, carefully check the connectors of sensors and actuators.
- Faulty contact could be due to rusting of the connector terminals, to foreign materials entering terminals or a drop in the contact pressure between the male and female terminals of the connector. Simply disconnecting and reconnecting the connectors once changes the condition of the connection and may result in a return to normal operation. Therefore, in troubleshooting, if no abnormality is found in the wire harness and connector check, but the problem disappears after the check, then the cause is considered to be in the wire harness or connectors.

SHORT CIRCUIT:

This could be due to a short circuit between the wire harness and the body ground or to a short inside the switch etc.

HINT:

When there is a short between the wire harness and body ground, check thoroughly whether the wire harness is caught in the body or is clamped properly.

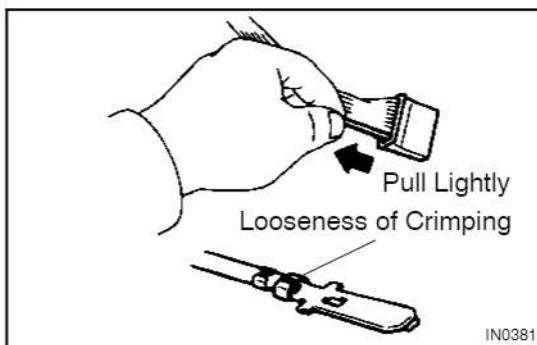
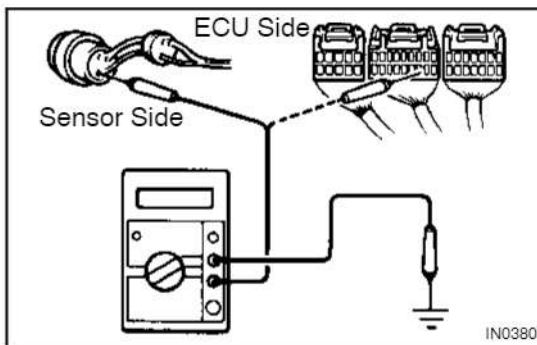
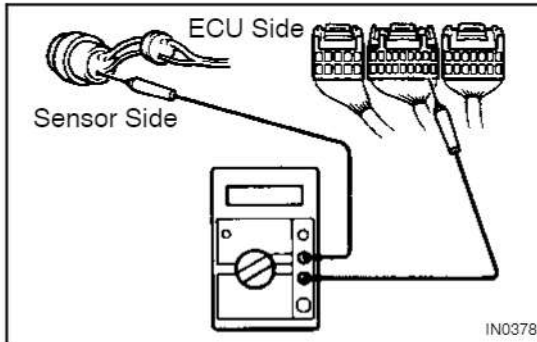
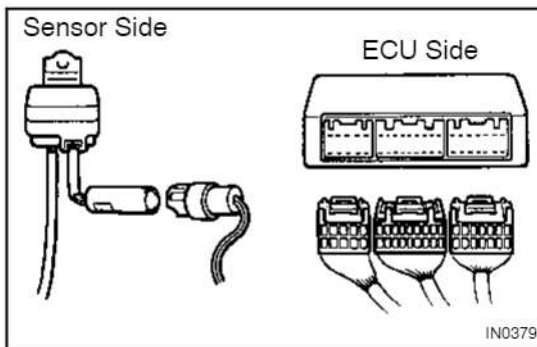

2. CONTINUITY CHECK (OPEN CIRCUIT CHECK)

- Disconnect the connectors at both ECU and sensor sides.
- Measure the resistance between the applicable terminals of the connectors.

Resistance: 1 Ω or less

HINT:

- Measure the resistance while lightly shaking the wire harness vertically and horizontally.
- When tester probes are inserted into a connector, insert the probes from the back. For waterproof connectors in which the probes cannot be inserted from the back, be careful not to bend the terminals when inserting the tester probes.

3. RESISTANCE CHECK (SHORT CIRCUIT CHECK)

- Disconnect the connectors at both ends.
- Measure the resistance between the applicable terminals of the connectors and body ground. Be sure to carry out this check on the connectors on both ends.

Resistance: 1 M Ω or higher

HINT:

Measure the resistance while lightly shaking the wire harness vertically and horizontally.

4. VISUAL CHECK AND CONTACT PRESSURE CHECK

- Disconnect the connectors at both ends.
- Check for rust or foreign material, etc. in the terminals of the connectors.
- Check crimped portions for looseness or damage and check if the terminals are secured in lock portion.

HINT:

The terminals should not come out when pulled lightly.

- Prepare a test male terminal and insert it in the female terminal, then pull it out.

NOTICE:

When testing a gold-plated female terminal, always use a gold-plated male terminal.

HINT:

When the test terminal is pulled out more easily than others, there may be poor contact in that section.

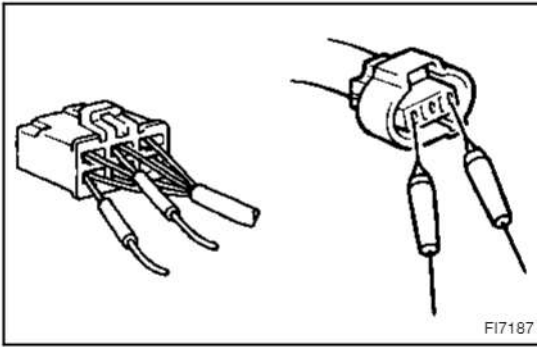

5. CONNECTOR HANDLING

When inserting tester probes into a connector, insert them from the rear of the connector. When necessary, use mini test leads. For water resistant connectors which cannot be accessed from behind, take good care not to deform the connector terminals.

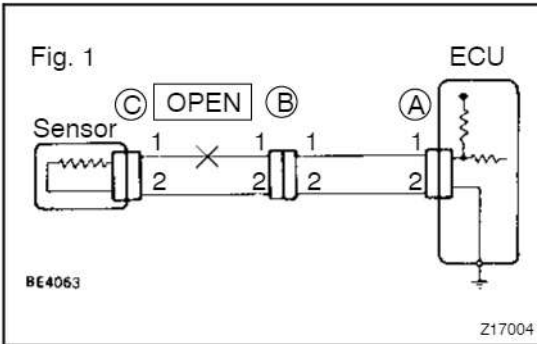

6. CHECK OPEN CIRCUIT

For the open circuit in the wire harness in Fig.1, perform "(a) Continuity Check" or "(b) Voltage Check" to locate the section.

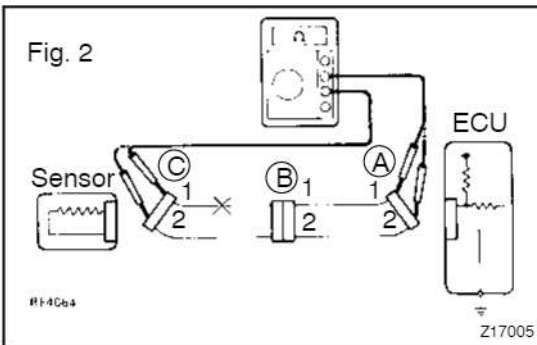

(a) Check the continuity.

(1) Disconnect connectors "A" and "C" and measure the resistance between them.

In the case of Fig.2,

Between terminal 1 of connector "A" and terminal 1 of connector "C" → No continuity (open)

Between terminal 2 of connector "A" and terminal 2 of connector "C" → Continuity

Therefore, it is found out that there is an open circuit between terminal 1 of connector "A" and terminal 1 of connector "C".

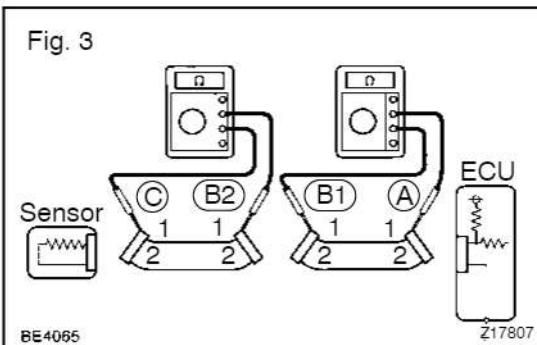

(2) Disconnect connector "B" and measure the resistance between them.

In the case of Fig.3,

Between terminal 1 of connector "A" and terminal 1 of connector "B1" → Continuity

Between terminal 1 of connector "B2" and terminal 1 of connector "C" → No continuity (open)

Therefore, it is found out that there is an open circuit between terminal 1 of connector "B2" and terminal 1 of connector "C".

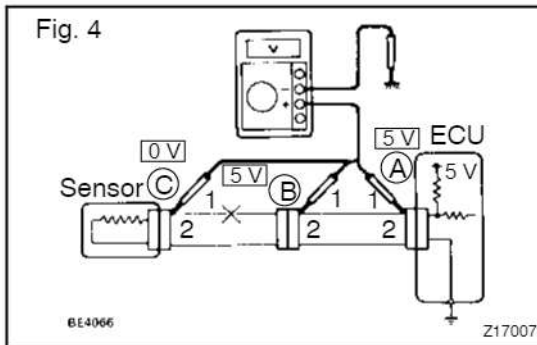

(b) Check the voltage.

In a circuit in which voltage is applied (to the ECU connector terminal), an open circuit can be checked for by conducting a voltage check.

As shown in Fig.4, with each connector still connected, measure the voltage between body ground and terminal 1 of connector "A" at the ECU 5V output terminal, terminal 1 of connector "B", and terminal 1 of connector "C", in that order.

If the results are:

5V: Between Terminal 1 of connector "A" and Body Ground

5V: Between Terminal 1 of connector "B" and Body Ground

0V: Between Terminal 1 of connector "C" and Body Ground

Then it is found out that there is an open circuit in the wire harness between terminal 1 of "B" and terminal 1 of "C".

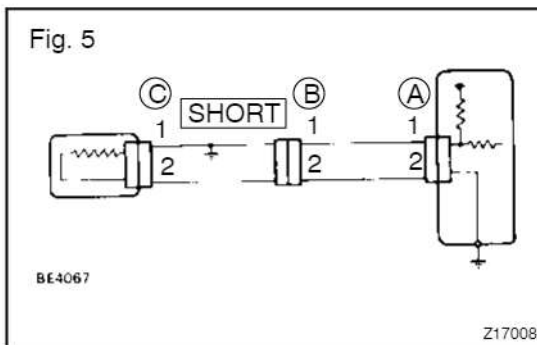
**7. CHECK SHORT CIRCUIT**

If the wire harness is ground shorted as in Fig.5, locate the section by conducting a "continuity check with ground".

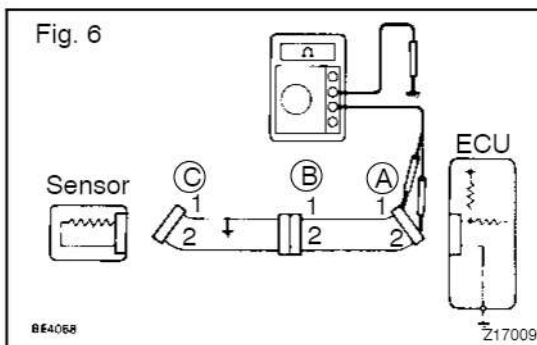

Check the continuity with ground.

- (1) Disconnect connectors "A" and "C" and measure the resistance between terminal 1 and 2 of connector "A" and body ground.

In the case of Fig.6

Between terminal 1 of connector "A" and body ground → Continuity (short)

Between terminal 2 of connector "A" and body ground → No continuity

Therefore, it is found out that there is a short circuit between terminal 1 of connector "A" and terminal 1 of connector "C".

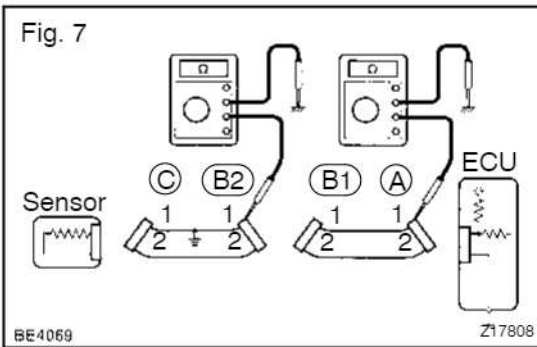

- (2) Disconnect connector "B" and measure the resistance between terminal 1 of connector "A" and body ground, and terminal 1 of connector "B2" and body ground.
- Between terminal 1 of connector "A" and body ground → No continuity
- Between terminal 1 of connector "B2" and body ground → Continuity (short)
- therefore, it is found out that there is a short circuit between terminal 1 of connector "B2" and terminal 1 of connector "C".

8. CHECK AND REPLACE ECU

First check the ECU ground circuit. If it is faulty, repair it. If it is normal, the ECU could be faulty, so replace the ECU with a known good one and check if the symptoms appear.

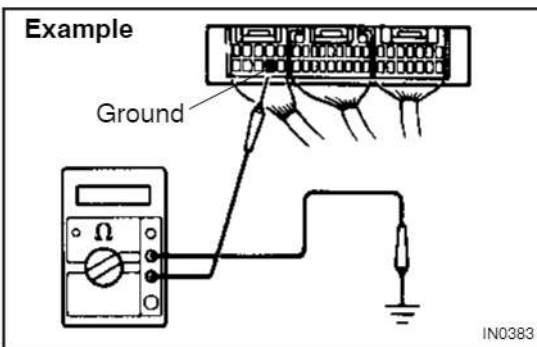

- (1) Measure the resistance between the ECU ground terminal and the body ground.

Resistance: 1 Ω or less

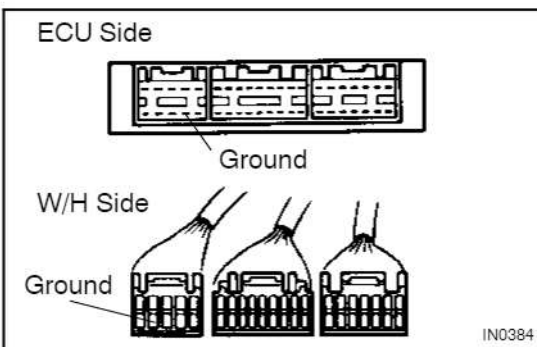

- (2) Disconnect the ECU connector, check the ground terminals on the ECU side and the wire harness side for bend and check the contact pressure.

TERMS**ABBREVIATIONS USED IN THIS MANUAL**

IN01M-04









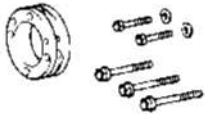

Abbreviations	Meaning
ACSD	Automatic Cold Start Device
A/C	Air Conditioner
Approx.	Approximately
A/T	Automatic Transmission
BTDC	Before Top Dead Center
BACS	Boost and Altitude Compensation Stopper
CCo	Catalytic Converter for Oxidation
ECD	Electronic Control Diesel
ECU	Electronic Control Unit
EGR	Exhaust Gas Recirculation
E-VRV	Electronic Vacuum Regulating Valve
EX	Exhaust
EDU	Electronic Drive Unit
FIPG	Formed In Place Gasket
FL	Fusible Link
HAC	High Altitude Compensator
IG	Ignition
IN	Intake
J/C	Junction Connector
LH	Left-Hand
M/T	Manual Transmission
MP	Multipurpose
LHD	Left-Hand Drive
O/S	Oversized
PCV	Positive Crankcase Ventilation
RH	Right-Hand
RHD	Right-Hand Drive
SSM	Special Service Materials
SST	Special Service Tools
STD	Standard
SW	Switch
TDC	Top Dead Center
U/S	Undersized
VSV	Vacuum Switching Valve
w/	With
w/ o	Without

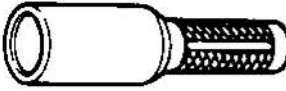

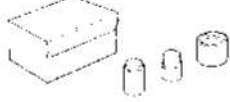



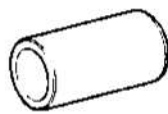

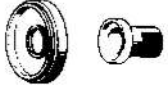

cardiagn.com

ENGINE MECHANICAL

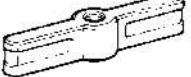
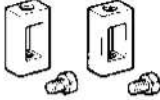

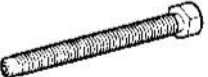

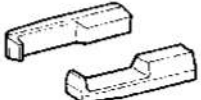

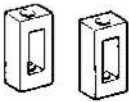

SST (Special Service Tools)

PP35E-01

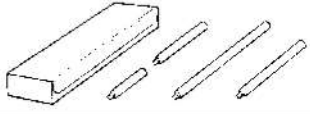

	09213-58013	Crankshaft Pulley Holding Tool	
	(90201-08131)	Washer	
	(91111-50845)	Bolt	
	09214-60010	Crankshaft Pulley & Gear Replacer	Crankshaft pulley
	09214-76011	Crankshaft Pulley Replacer	Injection pump drive gear oil seal Crankshaft front oil seal
	09222-17011	Connecting Rod Bushing Remover & Replacer	
	(09222-05021)	Remover & Replacer	
	(09222-05031)	Guide	
	(09222-05041)	Base	
	09223-00010	Cover & Seal Replacer	Crankshaft timing gear Oil pump drive shaft gear
	09223-15020	Oil Seal & Bearing Replacer	Drive gear bearing
	09223-78010	Crankshaft Oil Seal Replacer	Crankshaft front oil seal

	09308-10010	Oil Seal Puller	Crankshaft front oil seal
	09330-00021	Companion Flange Holding Tool	Crankshaft pulley
	09502-12010	Differential Bearing Replacer	
	09950-40011	Puller B Set	
	(09951-04010)	Hanger 150	No.1 camshaft timing pulley Oil pump drive shaft gear Crankshaft timing gear Injection pump drive gear bearing
	(09952-04010)	Slide Arm	No.1 camshaft timing pulley Oil pump drive shaft gear Crankshaft timing gear Injection pump drive gear bearing
	(09953-04010)	Center Bolt 100	Oil pump drive shaft gear Crankshaft timing gear
	(09953-04020)	Center Bolt 150	No.1 camshaft timing pulley Oil pump drive shaft gear Crankshaft timing gear Injection pump drive gear bearing
	(09954-04010)	Arm 25	No.1 camshaft timing pulley Oil pump drive shaft gear Crankshaft timing gear Injection pump drive gear bearing
	(09955-04041)	Claw No.4	Injection pump drive gear bearing
	(09955-04061)	Claw No.6	No.1 camshaft timing pulley Oil pump drive shaft gear Crankshaft timing gear
	09950-50013	Puller C Set	
	(09951-05010)	Hanger 150	Crankshaft pulley Injection pump drive gear

PREPARATION - ENGINE MECHANICAL

	(09952-05010) Slide Arm	Crankshaft pulley Injection pump drive gear
	(09953-05010) Center Bolt 100	Crankshaft pulley Injection pump drive gear Crankshaft front oil seal
	(09953-05020) Center Bolt 150	Crankshaft pulley
	(09954-05021) Claw No.2	Crankshaft pulley Injection pump drive gear
	09950-70010 Handle Set	
	(09951-07100) Handle 100	Valve guide bushing Injection pump drive gear
	09960-10010 Variable Pin Wrench Set	
	(09962-01000) Variable Pin Wrench Arm Assy	Injection pump drive gear
	(09963-00600) Pin 6	Injection Pump drive gear

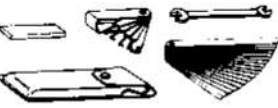
RECOMMENDED TOOLS

	09040-00011 Hexagon Wrench Set .	
	09200-00010 Engine Adjust Kit .	
	09904-00010 Expander Set .	

EQUIPMENT

Carbide cutter	
Caliper gauge	
Connecting rod aligner	
Cylinder gauge	
Dial indicator	
Dye penetrant	
Engine tune-up tester	
Gasket scraper	
Heater	
Micrometer	
Magnetic finger	
Piston ring compressor	
Piston ring expander	
Plastigage	
Precision straight edge	
Soft brush	
Spring tester	Valve spring
Steel square	Valve spring
Tachometer	
Thermometer	
Torque wrench	
Valve seat cutter	
V-block	
Vernier calipers	

SSM (Special Service Materials)

08826-00080	Seal Packing Black or equivalent (FIG)	Timing belt cover Timing gear cover Camshaft oil seal retainer Cylinder head semi-circular plug
08826-00080	Seal Packing Black or equivalent (FIG)	Cylinder head caver
08826-00100	Seal Packing 1282B, THREE BOND 1282B or equivalent (FIG)	Water sender gauge
08833-00080	Adhesive 1344 THREE BOND 1344 LOCTITE 242 or equivalent	Idler pulley

TURBOCHARGING

SST (Special Service Tools)

PF1TQ-02

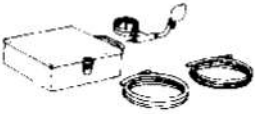
	09992-00242 Turbocharger Pressure Gauge	
---	---	--

cardiagn.com

EQUIPMENT

Dial indicator	Impeller wheel
Torque wrench	

EMISSION CONTROL RECOMMENDED TOOLS

PF15X-01

	09082-00040 TOYOTA Electrical Tester.	
---	---------------------------------------	--

cardiagn.com

EQUIPMENT

MITYVAC (Hand-held vacuum tester)	
Torque wrench	

ELECTRONIC CONTROL DIESEL

RECOMMENDED TOOLS

PP30F-01

	09082-00040 TOYOTA Electrical Tester.	
---	---------------------------------------	--

EQUIPMENT

MITYVAC (Hand-held vacuum tester)	
Torque wrench	

ENGINE FUEL

SST (Special Service Tools)

PP30P-01







	09992-00242 Turbocharger Pressure Gauge	
---	---	--

EQUIPMENT

Brass brush	
Injection nozzle tester	
Torque wrench	

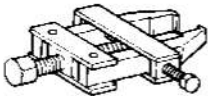
CHARGING**SST (Special Service Tools)**

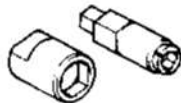
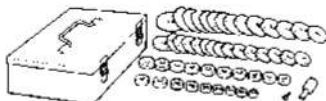
PP350-01

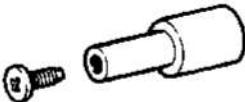
	09285-76010	Injection Pump Camshaft Bearing Cone Replacer	Rotor rear bearing cover
	09286-46011	Injection Pump Spline Shaft Puller	Rectifier end frame
	09820-00021	Alternator Rear Bearing Puller	
	09820-00031	Alternator Rear Bearing Replacer	
	09820-63011	Alternator Pulley Set Nut Wrench Set	
	09950-60010	Replacer Set	Rotor front bearing
	(09951-00260)	Replacer 26	
	(09951-00500)	Replacer 50	
	(09952-06010)	Adapter	

RECOMMENDED TOOLS

	09082-00040 TOYOTA Electrical Tester.	
---	---------------------------------------	--

cardiagn.com











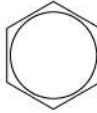

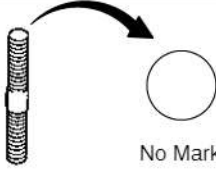
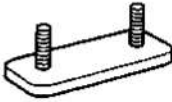













EQUIPMENT

Ammeter(A)	
Battery specific gravity gauge	Except maintenance-free battery
Torque wrench	
Vernier calipers	Rotor (Slip ring)
Plastic hammer	

STANDARD BOLT

HOW TO DETERMINE BOLT STRENGTH

SS028-01

Bolt Type				Class
Hexagon Head Bolt		Stud Bolt	Weld Bolt	
Normal Recess Bolt	Deep Recess Bolt			
  No Mark	 No Mark	 No Mark		4T
 				5T
  w/ Washer	 w/ Washer			6T
 	 			7T
		 		8T
				9T
	 			10T
	 			11T

cardiagn.com







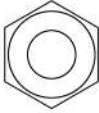
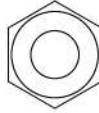
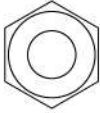

B06431

SPECIFIED TORQUE FOR STANDARD BOLTS

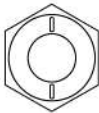
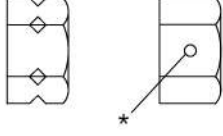
Class	Diameter mm	Pitch mm	Specified torque					
			Hexagon head bolt			Hexagon flange bolt		
			N·m	kgf·cm	ft·lbf	N·m	kgf·cm	ft·lbf
4T	6	1	5	55	48 in·lbf	6	60	52 in·lbf
	8	1.25	12.5	130	9	14	145	10
	10	1.25	26	260	19	29	290	21
	12	1.25	47	480	35	53	540	39
	14	1.5	74	760	55	84	850	61
	16	1.5	115	1,150	83	-	-	-
5T	6	1	6.5	65	56 in·lbf	7.5	75	65 in·lbf
	8	1.25	15.5	160	12	17.5	175	13
	10	1.25	32	330	24	36	360	26
	12	1.25	59	600	43	65	670	48
	14	1.5	91	930	67	100	1,050	76
	16	1.5	140	1,400	101	-	-	-
6T	6	1	8	80	69 in·lbf	9	90	78 in·lbf
	8	1.25	19	195	14	21	210	15
	10	1.25	39	400	29	44	440	32
	12	1.25	71	730	53	80	810	59
	14	1.5	110	1,100	80	125	1,250	90
	16	1.5	170	1,750	127	-	-	-
7T	6	1	10.5	110	8	12	120	9
	8	1.25	25	260	19	28	290	21
	10	1.25	52	530	38	58	590	43
	12	1.25	95	970	70	105	1,050	76
	14	1.5	145	1,500	108	165	1,700	123
	16	1.5	230	2,300	166	-	-	-
8T	8	1.25	29	300	22	33	330	24
	10	1.25	61	620	45	68	690	50
	12	1.25	110	1,100	80	120	1,250	90
9T	8	1.25	34	340	25	37	380	27
	10	1.25	70	710	51	78	790	57
	12	1.25	125	1,300	94	140	1,450	105
10T	8	1.25	38	390	28	42	430	31
	10	1.25	78	800	58	88	890	64
	12	1.25	140	1,450	105	155	1,600	116
11T	8	1.25	42	430	31	47	480	35
	10	1.25	87	890	64	97	990	72
	12	1.25	155	1,600	116	175	1,800	130

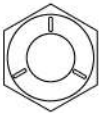
cardiagn.com

HOW TO DETERMINE NUT STRENGTH

Present Standard Hexagon Nut	Nut Type		Class
	Old Standard Hexagon Nut		
	Cold Forging Nut	Cutting Processed Nut	
 No Mark			4N
 No Mark (w/ Washer)	 No Mark (w/ Washer)	 No Mark	5N (4T)
 6N			6N
	 7N	 7N	7N (5T)
 8N			8N
 10N	 10N	 No Mark	10N (7T)
 11N			11N
 12N			12N

*: Nut with 1 or more marks on one side surface of the nut.

HINT:

Use the nut with the same number of the nut strength classification or the greater than the bolt strength classification number when tightening parts with a bolt and nut.

Example: Bolt = 4T

Nut = 4N or more

1HD-FTE ENGINE SUP (RM896E)

ENGINE MECHANICAL

SERVICE DATA

SS02E-05

A/C idle-up speed		775 - 875 rpm
Timing belt tensioner	Protrusion from husing end	9.0 - 9.8 mm (0.354 - 0.386 in.)
Timing gear	Idler gear thrust clearance	STD 0.07 - 0.12 mm (0.0028 - 0.0047 in.) Maximum 0.012 mm (0.0047 in.)
	Idler gear inside diameter	45.045 - 45.065 mm (1.7734 - 1.7742 in.)
	Idler gear shaft diameter	44.950 - 44.975 mm (1.7697 - 1.7707 in.)
	Idler gear oil clearance	STD 0.070 - 0.115 mm (0.0028 - 0.0045 in.) Maximum 0.115 mm (0.0045 in.)
Cylinder head	Warpage	Maximum 0.20 mm (0.079 in.)
	Valve seat Refacing angle	Intake 25° 45° 70° Exhaust 25° 45° 65°
	Contacting angle	45°
	Contacting width	Intake 1.4 - 1.8 mm (0.055 - 0.071 in.)
		Exhaust 1.6 - 2.0 mm (0.063 - 0.079 in.)
	Cylinder head bolt outer diameter	STD 10.800 - 11.000 mm (0.4252 - 0.4331 in.)
		Minimum 10.550 mm (0.4154 in.)
	New cylinder head gasket thickness	Cut number "1" 0.85 - 0.95 mm (0.0335 - 0.0374 in.)
		Cut number "3" 0.95 - 1.05 mm (0.0374 - 0.0414 in.)
		Cut number "5" 1.05 - 1.15 mm (0.0414 - 0.0453 in.)
Valve guide bushing	Inside diameter	7.010 - 7.030 mm (0.2760 - 0.2768 in.)
Valve	Valve overall length	STD Intake 126.85 - 127.45 mm (4.9941 - 5.0177 in.) Exhaust 126.83 - 127.43 mm (4.9933 - 5.0169 in.)
		Minimum Intake 126.85 mm (4.9941 in.) Exhaust 126.83 mm (4.9933 in.)
	Stem diameter	Intake 6.970 - 6.985 mm (0.2744 - 0.2750 in.)
		Exhaust 6.960 - 6.975 mm (0.2740 - 0.2746 in.)
	Stem oil clearance	STD Intake 0.025 - 0.060 mm (0.0010 - 0.0024 in.)
		Exhaust 0.035 - 0.070 mm (0.0014 - 0.0028 in.)
		Maximum Intake 0.08 mm (0.0031 in.) Exhaust 0.10 mm (0.0039 in.)
	Margin thickness	STD 1.00 mm (0.394 in.)
Minimum 0.083 mm (0.0327 in.)		
Valve spring	Free length	49.60 mm (1.9527 in.)
	Install tension at 39.5 mm (1.555 in.)	237 - 263 N (24.2 - 26.8 kgf, 53.4 - 59.1 lbf)
	Deviation Maximum	2.0 mm (0.079 in.)
Valve rocker arm and shaft	Valve rocker arm inside diameter	20.012 - 20.033 mm (0.7879 - 0.7887 in.)
	Valve rocker shaft diameter	19.972 - 19.993 mm (0.7879 - 0.7887 in.)
	Oil clearance	STD 0.019 - 0.061 mm (0.0007 - 0.0024 in.) Maximum 0.10 mm (0.0039 in.)

SERVICE SPECIFICATIONS - ENGINE MECHANICAL

Camshaft	Thrust clearance	STD	0.10 – 0.20 mm (0.0039 – 0.00 in.)
		Maximum	0.30 mm (0.0118 in.)
	Standard oil clearance	STD No.1	0.022 – 0.074 mm (0.0009 – 0.0029 in.)
		Other	0.023 – 0.075 mm (0.0009 – 0.0030 in.)
		Maximum	0.10 mm (0.0039 in.)
	Journal diameter	No.1	34.969 – 34.985 mm (1.3767 – 1.3774 in.)
		Other	27.986 – 28.002 mm (1.1018 – 1.1024 in.)
Cam lobe height	STD Intake	48.203 – 48.303 mm (1.8978 – 1.9017 in.)	
	Exhaust	50.734 – 50.834 mm (1.9974 – 2.0013 in.)	
	Minimum Intake	47.998 mm (1.8897 in.)	
	Exhaust	50.234 mm (1.9777 in.)	
Circle runout		0.10 mm (0.0039 in.)	
Manifold	Warpage	Maximum	0.40 mm (0.0157 in.)
Cylinder block	Cylinder head surface warpage	Maximum	0.20 mm (0.0079 in.)
	Cylinder bore diameter	STD Mark "1"	94.000 – 94.010 mm (3.7001 – 3.7012 in.)
		Mark "2"	94.010 – 94.020 mm (3.7012 – 3.7016 in.)
		Mark "3"	94.020 – 94.030 mm (3.7016 – 3.7020 in.)
	Main bearing cap stud bolt Tension portion diameter	Maximum STD	94.23 mm (3.7098 in.)
O/S 0.50		94.73 mm (3.7295 in.)	
	STD	11.80 – 12.00 mm (0.4646 – 0.4724 in.)	
	Minimum	11.50 mm (0.4528 in.)	
Piston and piston ring	Piston diameter	STD Mark "1"	93.870 – 93.880 mm (3.69566 – 3.69606 in.)
		Mark "2"	93.881 – 93.890 mm (3.69609 – 3.69645 in.)
		Mark "3"	93.891 – 93.900 mm (3.69649 – 3.69684 in.)
		O/S 0.50	94.370 – 94.400 mm (3.71535 – 3.71653 in.)
	Piston oil clearance	STD	0.070 – 0.090 mm (0.0028 – 0.0035 in.)
		Maximum	0.090 mm (0.0035 in.)
	Piston ring groove clearance	No.1 STD	0.070 – 0.110 mm (0.0028 – 0.0043 in.)
		Maximum	0.20 mm (0.0079 in.)
		No.2 STD	0.040 – 0.080 mm (0.0016 – 0.0031 in.)
		Maximum	0.20 mm (0.0079 in.)
		Oil ring STD	0.030 – 0.070 mm (0.0012 – 0.0028 in.)
		Maximum	0.20 mm (0.0079 in.)
	Piston ring end gap	No.1 STD	0.270 – 0.330 mm (0.0106 – 0.0130 in.)
		Maximum	0.850 mm (0.0335 in.)
		No.2 STD	0.400 – 0.550 mm (0.0157 – 0.0119 in.)
Maximum		0.900 mm (0.0354 in.)	
Oil ring STD		0.200 – 0.500 mm (0.0079 – 0.0157 in.)	
	Maximum	0.880 mm (0.0346 in.)	

Connecting rod	Rod bend maximum per 100 mm (3.94 in.)		0.03 mm (0.0012 in.)
	Rod twist maximum per 100 mm (3.94 in.)		0.15 mm (0.0059 in.)
	Busing inside diameter		33.008 – 33.020 mm (1.2995 – 1.3000 in.)
	Piston pin diameter		33.000 – 33.012 mm (1.2992 – 1.2997 in.)
	Bushing oil clearance	STD	0.004 – 0.012 mm (0.0002 – 0.0005 in.)
		Maximum	0.030 mm (0.0012 in.)
Connecting rod bolt tension portion diameter		STD	8.300 – 8.400 mm (0.3268 – 0.3307 in.)
		Maximum	7.950 mm (0.3130 in.)
Crankshaft	Main journal diameter	STD	66.982 – 67.000 mm (2.6371 – 2.6378 in.)
		U/S 0.25	66.745 – 66.755 mm (2.6278 – 2.6281 in.)
		U/S 0.50	66.495 – 66.505 mm (2.6179 – 2.6183 in.)
	Main bearing center wall thickness (Reference)	Mark "3"	1.982 – 1.985 mm (0.07803 – 0.07815 in.)
		Mark "4"	1.985 – 1.988 mm (0.07815 – 0.07827 in.)
		Mark "5"	1.988 – 1.991 mm (0.07827 – 0.07839 in.)
		Mark "6"	1.991 – 1.994 mm (0.07839 – 0.07850 in.)
		Mark "7"	1.994 – 1.997 mm (0.07850 – 0.07862 in.)
		Mark "8"	1.997 – 2.000 mm (0.07862 – 0.07874 in.)
	Circle runout		0.06 mm (0.0024 in.)
Main journal taper and out-of-round		0.02 mm (0.0008 in.)	

TORQUE SPECIFICATION

Part tightened	N·m	kgf·cm	ft·lbf	
Timing gear case x Injection pump	18	185	13	
Injection pump x Injection pipe union nuts	24.5	250	18	
Injection pipe x Injection pump	24.5	250	18	
Intake heater x Throttle body	19.6	200	14	
Camshaft x No.1 camshaft timing pulley	98	1,000	72	
Timing gear cover x timing belt tensioner	13	130	10	
Timing gear cover x Idler pulley	34.5	350	25	
Injection pump drive gear x Injection pump	137	1,397	101	
Idler gear x Timing belt tensioner	68	694	50	
Timing gear cover x Cylinder block	19.6	200	14	
Oil pipe x Cylinder block, Vacuum pump	18	185	13	
Vacuum pump x Timing belt cover	39	400	29	
Crankshaft x Crankshaft pulley	430	4,400	317	
Cylinder head x Cylinder block	1st	68.6	700	51
	2nd	Turn 90°	Turn 90°	Turn 90°
	3rd	Turn 90°	Turn 90°	Turn 90°
Cylinder head x bearing cap	25	250	18	
Camshaft oil seal retainer x Cylinder head	19.6	200	14	
Cylinder head cover x Cylinder head	8	82	71 in.·lbf	
Glow plug x Cylinder head	12.7	130	9	
Intake manifold assembly x Cylinder head	19.6	200	14	
Intake pipe x Intake manifold	19.6	200	14	
EGR cooler pipe x Intake pipe	19.6	200	14	
EGR cooler pipe x Exhaust manifold	39.2	400	29	
Exhaust manifold x Cylinder head	41.7	425	31	

TURBOCHARGING

SERVICE DATA

SS02G-03

Turbocharger	Turbocharging pressure Turbine wheel axial play Actuator push rod stroke	30.0 – 50.0 kPa (0.29 – 0.49 kgf/cm ² , 4.4 – 7.3 psi) Maximum 0.083 mm (0.00327 in.) or less 50.7 kPa (375 mmHg, 15 in.Hg) 26.6 kPa (220 mmHg, 8 in.Hg) 0.2 mm (0.008 in.) 5.0 mm (0.197 in.)
Turbo pressure sensor	Voltage	4.75 – 5.25 V
E-VRV for turbocharging pressure control	Resistance At 20°C (68°F)	11 – 13 Ω

TORQUE SPECIFICATION

Part tightened	N·m	kgf·cm	ft·lbf
EGR w/cooler pipe sub-assy x Exhaust manifold assembly	39.2	400	29
Exhaust manifold assembly x Cylinder head	41.7	425	31
EGR w/cooler pipe sub-assy x Intake pipe assembly	19.6	200	14
Intake pipe bracket x Intake pipe assembly	19.6	200	14
Intake pipe bracket x Cylinder head	19.6	200	14
Heat insulator x Cylinder head	18.1	185	13.4
Heat insulator x Turbocharger assembly	18.1	185	13.4
Turbocharger assembly x Exhaust manifold assembly	52	530	38
Turbo oil pipe x Turbocharger assembly	7.8	80	69 in.·lbf
No.1 turbo water pipe x Turbocharger assembly	7.8	80	69 in.·lbf
Turbo outlet elbow x Turbocharger assembly	52	530	38
Compressor inlet elbow x Turbocharger assembly	19.6	200	14
Turbocharger stay x Cylinder block	117.7	1200	86.8
Turbocharger stay x Turbocharger assembly	117.7	1200	86.8
Compressor outlet elbow x Turbocharger assembly	19.6	200	14

EMISSION CONTROL

SERVICE DATA

SS01M-04

E-VRV for EGR	at 20°C (68°F)	11 - 13 Ω
EGR cut VSV	at 20°C (68°F)	37 - 44 Ω

TORQUE SPECIFICATION

Part tightened	N·m	kgf·cm	ft·lbf
No.1 intake pipe x No.2 intake pipe	19.6	200	14
No.1 intake pipe x Intake pipe stay	19.6	200	14
EGR valve x EGR cooler pipe	19.6	200	14
EGR cooler pipe x Exhaust manifold	39.2	400	29

ELECTRONIC CONTROL DIESEL

SERVICE DATA

SS0L2-05

VSV for intake air control valve	Resistance at 20°C (68°F)	33 - 39, Ω
ECU	Resistance	
	LU+A ↔ +B	15 - 30 Ω
	LU-A ↔ +B	15 - 30 Ω
	LU+B ↔ +B	15 - 30 Ω
	LU-B ↔ +B	15 - 30 Ω
Intake air temp. 20°C (68°F)	THA ↔ E2	2.0 - 3.0 kΩ
Fuel temp. 20°C (68°F)	THF ↔ E2	2.0 - 3.0 kΩ
Coolant temp. 80°C (176°F)	THW ↔ E2	0.2 - 0.4 kΩ
Cold (-10°C (14°F) to 50°C (122°F)	TDC+ ↔ TDC-	19 - 37 Ω
Hot (-50°C (122°F) to 100°C (212°F)	TDC+ ↔ TDC-	24 - 37 Ω
	NE+ ↔ NE-	205 - 255 Ω
	TCV ↔ +B	10 - 16 Ω
	EGR ↔ +B	11 - 18 Ω
25°C (77°F)	EGRC ↔ +B	30 - 40 Ω
25°C (77°F)	S/TH- ↔ +B	30 - 40 Ω
25°C (77°F)	PA ↔ +B	30 - 40 Ω
	SVR ↔ +B	60 - 80 Ω
	IREL ↔ E01	4 - 8 Ω
	MREL ↔ E01	60 - 80 Ω
	SCV ↔ +B	30 - 40 Ω

TORQUE SPECIFICATION

Part tightened	N·m	kgf·cm	ft·lbf
Throttle body x Intake pipe	19.6	200	14
Intake manifold (w/ Intake air control valve) x Cylinder head	19.6	220	14

ENGINE FUEL

SERVICE DATA

SS00X-08

Injection nozzles (1HD-FTE)	Nozzle opening pressure	No.1	17,650 – 18,630 kPa (176.5 – 186.3 kgf/cm ² , 2,560 – 2,702 psi)
		No.2 (Inspection pressure)	27,460 – 28,440 kPa (247.6 – 284.4 kgf/cm ² , 3,983 – 4,125 psi)
	No.2 pressure spring washer (No.1 nozzle opening pressure adjusting shim) thickness		0.800 mm (0.0315 in.)
			0.825 mm (0.0325 in.)
			0.850 mm (0.0335 in.)
			0.875 mm (0.0344 in.)
			0.900 mm (0.0354 in.)
			0.925 mm (0.0364 in.)
			0.950 mm (0.0374 in.)
			0.975 mm (0.0384 in.)
			1.000 mm (0.0394 in.)
			1.025 mm (0.0404 in.)
			1.050 mm (0.0413 in.)
			1.075 mm (0.0423 in.)
			1.100 mm (0.0433 in.)
			1.125 mm (0.0443 in.)
			1.150 mm (0.0453 in.)
			1.175 mm (0.0463 in.)
			1.200 mm (0.0472 in.)
			1.225 mm (0.0482 in.)
			1.250 mm (0.0492 in.)
			1.275 mm (0.0502 in.)
			1.300 mm (0.0512 in.)
			1.325 mm (0.0521 in.)
			1.350 mm (0.0531 in.)
			1.375 mm (0.0541 in.)
			1.400 mm (0.0551 in.)
			1.425 mm (0.0561 in.)
			1.450 mm (0.0571 in.)
			1.475 mm (0.0581 in.)
			1.500 mm (0.0591 in.)
			1.525 mm (0.0600 in.)
			1.550 mm (0.0610 in.)
			1.575 mm (0.0620 in.)
			1.600 mm (0.0630 in.)
			1.625 mm (0.0640 in.)
			1.650 mm (0.0650 in.)
			1.675 mm (0.0659 in.)
			1.700 mm (0.0669 in.)
			1.725 mm (0.0679 in.)
			1.750 mm (0.0689 in.)
			1.775 mm (0.0699 in.)
	No.1 pressure spring washer (No.2 nozzle opening pressure adjusting shim) thickness		0.700 mm (0.0276 in.)
			0.750 mm (0.0295 in.)
			0.800 mm (0.0315 in.)
			0.850 mm (0.0335 in.)
			0.900 mm (0.0354 in.)
			0.950 mm (0.0374 in.)
			1.000 mm (0.0394 in.)
			1.050 mm (0.0413 in.)
			1.100 mm (0.0433 in.)
			1.150 mm (0.0453 in.)
			1.200 mm (0.0472 in.)
			1.250 mm (0.0492 in.)
			1.300 mm (0.0512 in.)
			1.350 mm (0.0531 in.)
			1.400 mm (0.0551 in.)
			1.450 mm (0.0571 in.)
			1.500 mm (0.0591 in.)
			1.550 mm (0.0610 in.)
			1.600 mm (0.0630 in.)
			1.650 mm (0.0650 in.)
			1.700 mm (0.0669 in.)
			1.750 mm (0.0689 in.)
			1.800 mm (0.0709 in.)

cardiagn.com

SERVICE SPECIFICATIONS - ENGINE FUEL

Injection nozzles (1HD-FTE) (Cont'd)	No.1 pressure spring washer (No.2 nozzle opening pressure adjusting shim) thickness (Cont'd)	1.850 mm (0.0728 in.)	1.900 mm (0.0748 in.)
		1.950 mm (0.0768 in.)	2.000 mm (0.0787 in.)
		2.050 mm (0.0807 in.)	2.100 mm (0.0827 in.)
		2.150 mm (0.0846 in.)	

TORQUE SPECIFICATION

Part tightened	N·m	kgf·cm	ft·lbf
Nozzle holder body x Nozzle holder retaining nut	29.4	300	22
Injection nozzle x Cylinder head	25	255	18
Injection pipe x Injection nozzle, Injection pump	24.5	250	18
Injection pipe clamp x Intake manifold, Injection pipe clamp	6.4	65	56 in.·lbf
No.3 nozzle leakage pipe x Intake manifold	19.6	200	14
Nozzle leakage pipe x Injection nozzle	11.3	115	8
Nozzle leakage pipe x Cylinder head	19	186	14

CHARGING

SERVICE DATA

SS01W-12

Battery	Specific gravity	at 20°C (68°F)	1.25 - 1.29
	Voltage	at 20°C (68°F)	12.5 - 12.9 V
Drive belt	Deflection	New belt	6 - 7 mm (0.24 - 0.28 in.)
		Used belt	8 - 11 mm (0.31 - 0.43 in.)
	Tension	New belt	441 - 539 N (45 - 55 kgf)
		Used belt	196 - 343 N (20 - 35 kgf)
Alternator	Rated output		12 V 80 A
	Rotor coil resistance	at 20°C (68°F)	2.1 - 2.5 Ω
	Slip ring diameter	STD	14.2 - 14.4 mm (0.559 - 0.567 in.)
		Minimum	12.8 mm (0.504 in.)
	Brush exposed length	STD	10.5 mm (0.413 in.)
Minimum		1.5 mm (0.059 in.)	
IC regulator	Regulating voltage		13.2 - 14.8 V

TORQUE SPECIFICATION

Part tightened	N·m	kgf·cm	ft·lbf
Retainer x Drive end frame	3.0	31	27 in.·lbf
Rectifier end frame x Drive end frame	4.5	46	40 in.·lbf
Rectifier end frame with cord clip x Drive end frame	5.4	55	48 in.·lbf
Alternator pulley x Rotor	110.5	1,125	81
Rectifier holder x Lead wire on rectifier end frame	2.94	30	26 in.·lbf
IC regulator x Rectifier end frame	2.0	20	18 in.·lbf
IC regulator x Rectifier holder	2.0	20	18 in.·lbf
Brush holder x Rectifier holder	2.0	20	18 in.·lbf
Brush holder x IC regulator	2.0	20	18 in.·lbf
Rear end cover x Rectifier holder	4.4	45	39 in.·lbf
Plate terminal x Rectifier holder	3.85	39	34 in.·lbf
Terminal insulator x Rectifier holder	4.1	42	36 in.·lbf

ENGINE (European Spec.)

HOW TO PROCEED WITH TROUBLESHOOTING

DI31H-10

When using hand-held tester, troubleshoot in accordance with the procedure on the following pages.

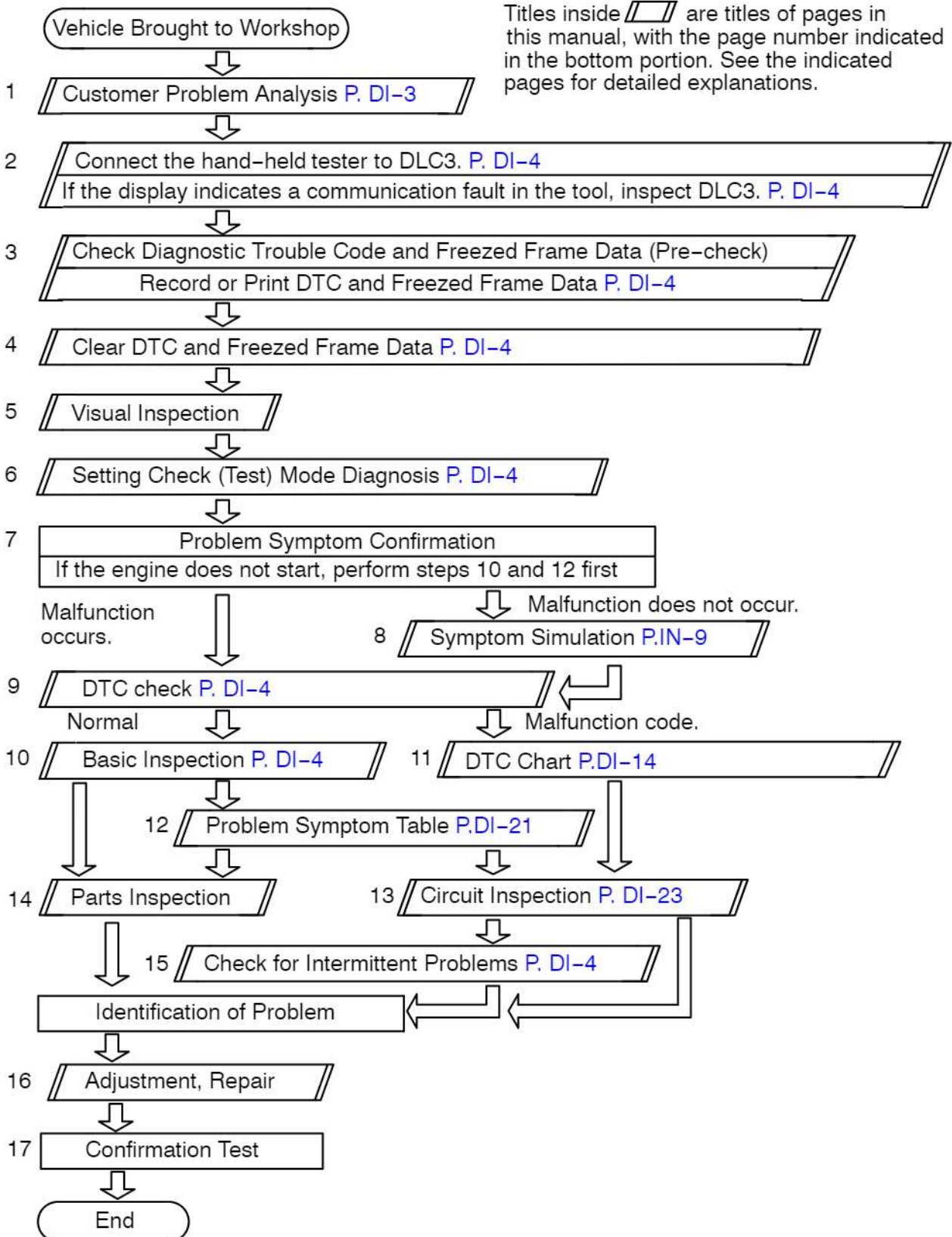

When not using hand-held tester, troubleshoot in accordance with the procedure on the following pages.

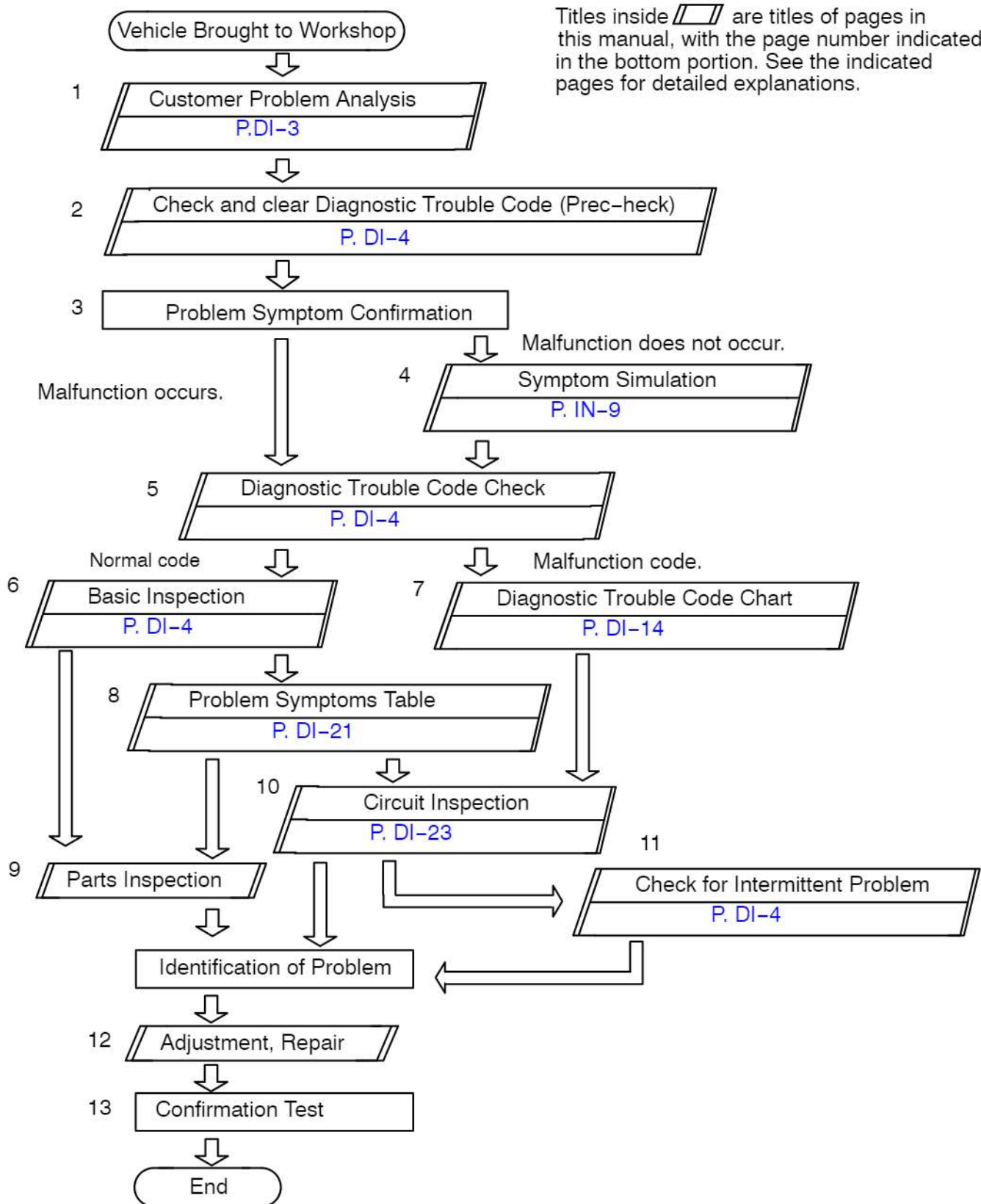

CUSTOMER PROBLEM ANALYSIS CHECK

ENGINE CONTROL SYSTEM Check Sheet

 Inspector's
Name

Customer's Name		Model and Model Year	
Driver's Name		Frame No.	
Date Vehicle Brought in		Engine Model	
License No.		Odometer Reading	km miles

Problem Symptoms	<input type="checkbox"/> Engine does not Start	<input type="checkbox"/> Engine does not crank	<input type="checkbox"/> No initial combustion	<input type="checkbox"/> No complete combustion
	<input type="checkbox"/> Difficult to Start	<input type="checkbox"/> Engine cranks slowly <input type="checkbox"/> Other _____		
	<input type="checkbox"/> Poor Idling	<input type="checkbox"/> Incorrect first idle <input type="checkbox"/> Idling rpm is abnormal <input type="checkbox"/> High (rpm) <input type="checkbox"/> Low (rpm) <input type="checkbox"/> Rough idling <input type="checkbox"/> Other _____		
	<input type="checkbox"/> Poor Driveability	<input type="checkbox"/> Hesitation <input type="checkbox"/> Back fire <input type="checkbox"/> Muffler explosion (after-fire) <input type="checkbox"/> Surging <input type="checkbox"/> Knocking <input type="checkbox"/> Other _____		
	<input type="checkbox"/> Engine Stall	<input type="checkbox"/> Soon after starting <input type="checkbox"/> After accelerator pedal depressed <input type="checkbox"/> After accelerator pedal released <input type="checkbox"/> During A/C operation <input type="checkbox"/> Shifting from N to D <input type="checkbox"/> Other _____		
	<input type="checkbox"/> Others	_____		

Dates Problem Occurred		_____		
Problem Frequency		<input type="checkbox"/> Constant <input type="checkbox"/> Sometimes (times per day/month) <input type="checkbox"/> Once only <input type="checkbox"/> Other _____		
Condition When Problem Occurs	Weather	<input type="checkbox"/> Fine <input type="checkbox"/> Cloudy <input type="checkbox"/> Rainy <input type="checkbox"/> Snowy <input type="checkbox"/> Various/Other _____		
	Outdoor Temperature	<input type="checkbox"/> Hot <input type="checkbox"/> Warm <input type="checkbox"/> Cool <input type="checkbox"/> Cold (approx. ____ °F/ ____ °C)		
	Place	<input type="checkbox"/> Highway <input type="checkbox"/> Suburbs <input type="checkbox"/> Inner City <input type="checkbox"/> Uphill <input type="checkbox"/> Downhill <input type="checkbox"/> Rough road <input type="checkbox"/> Other _____		
	Engine Temp.	<input type="checkbox"/> Cold <input type="checkbox"/> Warming up <input type="checkbox"/> After Warming up <input type="checkbox"/> Any temp. <input type="checkbox"/> Other _____		
	Engine Operation	<input type="checkbox"/> Starting <input type="checkbox"/> Just after starting (min.) <input type="checkbox"/> Idling <input type="checkbox"/> Racing <input type="checkbox"/> Driving <input type="checkbox"/> Constant speed <input type="checkbox"/> Acceleration <input type="checkbox"/> Deceleration <input type="checkbox"/> A/C switch ON/OFF <input type="checkbox"/> Other _____		

Condition of Malfunction indicator Lamp		<input type="checkbox"/> Remains on <input type="checkbox"/> Sometimes light up <input type="checkbox"/> Does not light up		
Diagnostic Trouble Code Inspection	Normal mode (Precheck)	<input type="checkbox"/> Normal <input type="checkbox"/> Malfunction code(s) (code) <input type="checkbox"/> Freezed frame data ()		
	Check Mode	<input type="checkbox"/> Normal <input type="checkbox"/> Malfunction code(s) (code) <input type="checkbox"/> Freezed frame data ()		

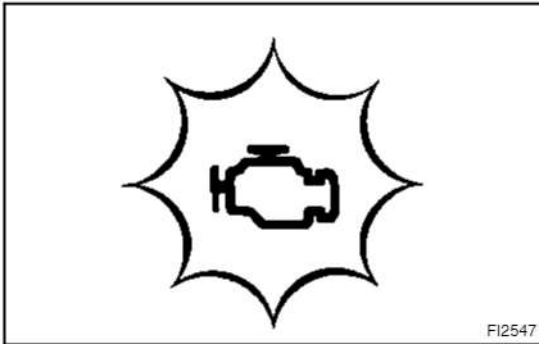

F12547

PRE-CHECK

1. DIAGNOSIS SYSTEM

(a) Description

- When troubleshooting Multiplex OBD (M-OBD) vehicles, the only difference from the usual troubleshooting procedure is that you connect to the vehicle the hand-held tester, and read off various data output from the vehicle's engine ECU.
- The vehicle's on-board computer lights up the check engine warning light on the instrument panel when the computer detects a malfunction in the computer itself or in drive system components. In addition to the check engine warning light lighting up when a malfunction is detected, the applicable diagnostic trouble codes are recorded in the engine ECU memory (See page DI-14).

If the malfunction has been repaired, the check engine warning light goes off automatically but the diagnostic trouble codes remain recorded in the engine ECU memory.

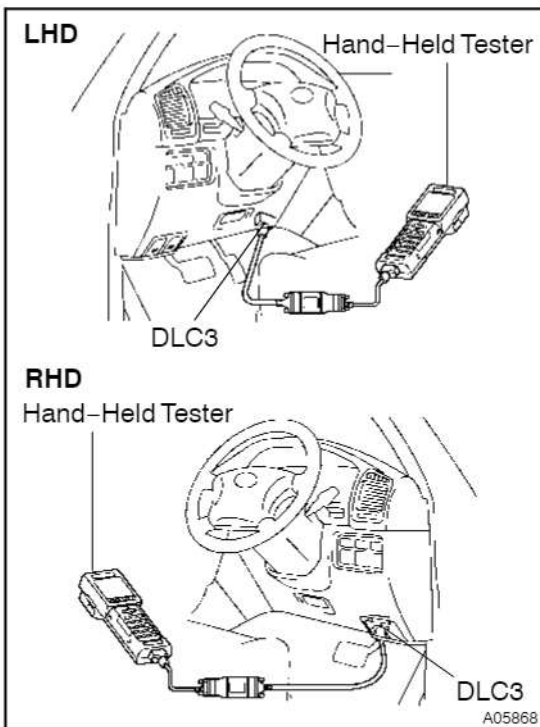

- To check the diagnostic trouble codes, connect the hand-held tester to Data Link Connector 3 (DLC3) on the vehicle or read the number of blinks of the check engine warning light when TC and CG terminals on the DLC3 are connected. The hand-held tester also enables you to erase the diagnostic trouble codes and activate the several actuators and check freeze frame date and various forms of engine data (For operating instructions, see the hand-held tester instruction book.).
- The diagnosis system operates in normal mode during normal vehicle use. It also has a check (test) mode for technicians to simulate malfunction symptoms and troubleshoot. Some diagnostic trouble codes use 2 trip detection logic* to prevent erroneous detection and ensure thorough malfunction detection. By switching the engine ECU to check (test) mode using hand-held tester when troubleshooting, the technician can cause the check engine warning light to light up for a malfunction that is only detected once or momentarily (hand-held tester only). (See page DI-14)

- *2 trip detection logic
When a logic malfunction is first detected, the malfunction is temporarily stored in the engine ECU memory. If the same malfunction is detected again during the second drive test, this second detection causes the check engine warning light to light up. The 2 trip repeats the same mode a 2nd time. (However, the IG switch must be turned OFF between the 1st trip and 2nd trip).
- Freeze frame data:
Freeze frame data records the engine condition when malfunction is detected.
- Because freeze frame data records the engine conditions (fuel system, calculator load, engine coolant temperature, fuel trim, engine speed, vehicle speed, etc.) when the malfunction is detected, when troubleshooting it is useful for determining whether the vehicle was running or stopped, the engine warmed up or not, the air-fuel ratio lean or rich, etc. at the time of the malfunction.

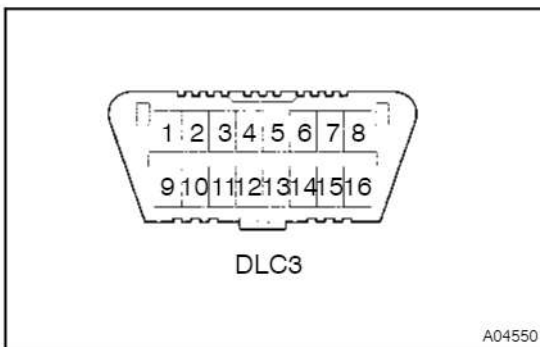

(b) Check the DLC3.

The vehicle's engine ECU uses ISO 14230 for communication. The terminal arrangement of DLC3 complies with ISO 15031-3 and matches the ISO 14230 format.

Terminal No.	Connection/Voltage or Resistance	Condition
7	Bus ⊕ Line / Pulse generation	During transmission
4	Chassis Ground / ↔ Body Ground 1 Ω or less	Always
16	Battery Positive / ↔ Body Ground 9 ~ 14 V	Always

HINT:

If your display shows "UNABLE TO CONNECT TO VEHICLE" when you have connected the cable of the hand-held tester to DLC3, turned the ignition switch ON and operated the hand-held tester, there is a problem on the vehicle side or tool side.

- If communication is normal when the tool is connected to another vehicle, inspect DLC3 on the original vehicle.
- If communication is still not possible when the tool is connected to another vehicle, the problem is probably in the tool itself, so consult the Service Department listed in the tool's instruction manual.

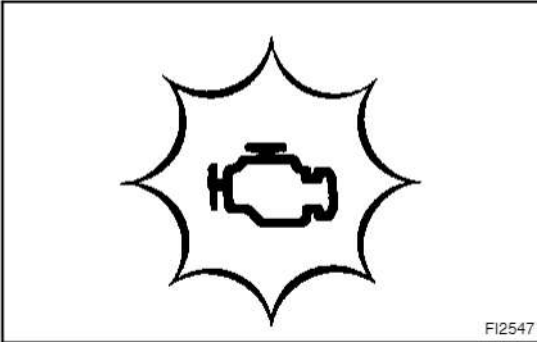

2. INSPECT DIAGNOSIS (Normal Mode)

- (a) Check the check engine warning light.
- (1) The check engine warning light comes on when the ignition switch is turned ON and the engine is not running.

HINT:

If the check engine warning light does not light up, troubleshoot the combination meter.

- (2) when the engine is started, the check engine warning light should go off. If the lamp remains on, the diagnosis system has detected a malfunction or abnormality in the system.

- (b) Check the DTC using hand-held tester.

NOTICE:

When the diagnosis system is switched from normal mode to check test mode, it erases all DTCs and frozen frame data recorded in normal mode. So before switching modes, always check the DTCs and frozen frame data, and note them down.

- (1) Prepare the hand-held tester.
- (2) Connect the hand-held tester to the DLC3.
- (3) Turn the ignition switch ON and switch the hand-held tester main switch ON.
- (4) Use the hand-held tester to check the DTCs and frozen frame data, note them down (for operating instructions, see the hand-held tester's instruction book.).
- (5) Confirm the details of the DTCs.

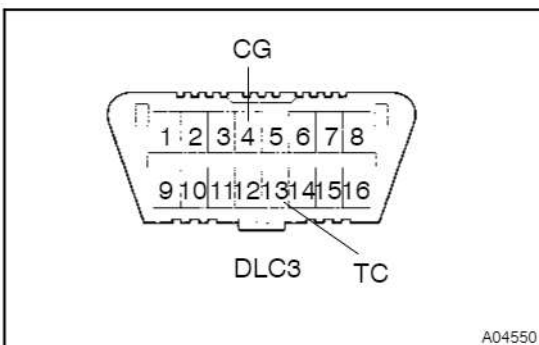

- (c) Check the DTC not using hand-held tester.
- (1) Turn the ignition switch ON.
 - (2) Using SST, connect between terminals 13 (TC) and 4 (CG) of DLC3.
SST 09843-18040

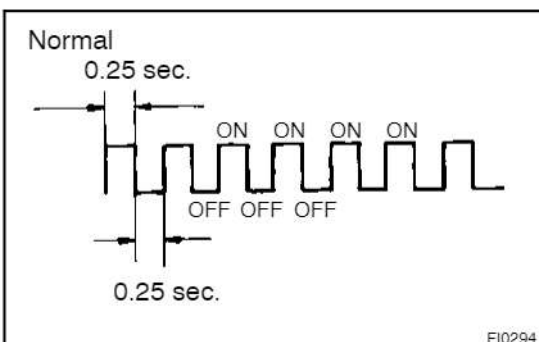

- (3) Read the diagnostic trouble code from check engine warning light.

HINT:

- If a diagnostic trouble code is not output, check the diagnostic connector (DLC3) circuit (See Pub. No. RM617E on page DI-100).

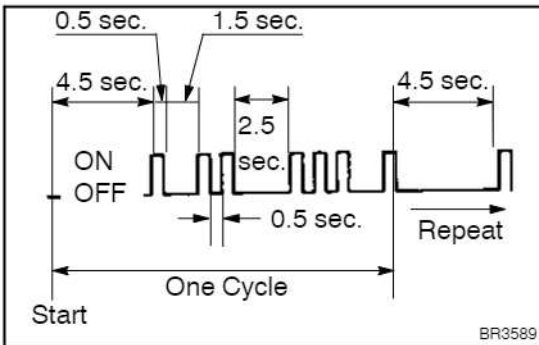

- As an example, the blinking patterns for codes; normal, 12 and 31 are as shown on the illustration.
- (4) Check the details of the malfunction using the diagnostic trouble code chart on [page DI-14](#).
- (5) After completing the check, disconnect terminals 13 (TC) and 4 (CG) and turn off the display.

HINT:

In the event of 2 or more malfunction codes, indication will begin from the smaller numbered code and continue in order to the larger.

NOTICE:

When simulating symptoms without a hand-held tester to check the DTCs, use normal mode. For code on the DTCs chart subject to "2 trip detection logic", turn the ignition switch OFF after the symptom is simulated the first time. Then repeat the simulation process again. When the problem has been simulated twice, the check engine warning light lights up and the DTCs are recorded in the engine ECU.

3. INSPECT DIAGNOSIS (Check (Test) Mode)**HINT:**

HAND-HELD TESTER only:

Compared to the normal mode, the check mode has an increased sensitivity to detect malfunctions.

Furthermore, the same diagnostic items which are detected in the normal mode can also be detected in the check (test) mode.

- (a) Check the DTC.
 - (1) Initial conditions.
 - Battery positive voltage 11 V or more
 - Throttle valve fully closed.
 - Transmission in neutral position
 - Air conditioning switched OFF.
 - (2) Turn the ignition switch OFF.
 - (3) Prepare the hand-held tester.
 - (4) Connect the hand-held tester to the DLC3.
 - (5) Turn the ignition switch ON and push the hand-held tester main switch ON.
 - (6) Switch the hand-held tester normal mode to check (test) mode (Check that the check engine warning light flashes.).
 - (7) Start the engine (The check engine warning light goes out after the engine start.).
 - (8) Simulate the conditions of the malfunction described by the customer.

NOTICE:

Leave the ignition switch ON until you have checked the DTCs, etc.

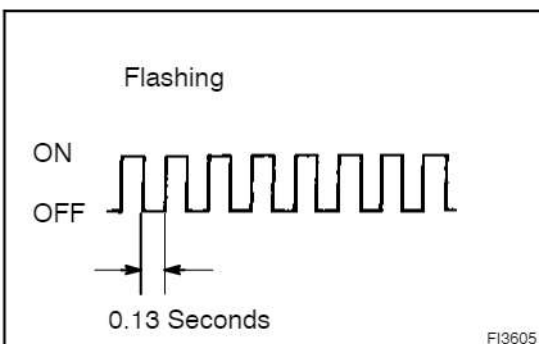

- (9) After simulating the malfunction conditions, use the hand-held tester diagnosis selector to check the DTCs and frozen frame data, etc.

HINT:

Take care not to turn the ignition switch OFF. Turning the ignition switch OFF switches the diagnosis system from check (test) mode to normal mode, so all diagnostic codes, etc. are erased.

- (10) After checking the DTCs, inspect the applicable circuit.
- (b) Clear the DTC.
The following actions will erase the DTCs and frozen frame data.

- (1) Operating the hand-held tester to erase the codes.
(See the hand-held tester's instruction book for operating instructions.)
- (2) Disconnecting the battery terminals or ECD fuse.

NOTICE:

If the hand-held tester switches the engine ECU from normal mode to check (test) mode or vice-versa, or if the ignition switch is turned from ON to ACC or OFF during check (test) mode, the DTCs and frozen frame data will be erased.

6. BASIC INSPECTION

When the malfunction code is not confirmed in the DTC check, troubleshooting should be carried out in the order for all possible circuits to be considered as the cases of the problems.

In many cases, by carrying out the basic engine check shown in the following flow chart, the location causing the problem can be found quickly and efficiently. Therefore, use of this check is essential in engine troubleshooting.

1	Is battery positive voltage 11 V or more when engine is stopped ?
----------	--

NO

Charge or replace battery.

YES

2	Is engine cranked ?
----------	----------------------------

NO

Proceed to problem symptoms table on [page DI-21](#).

YES

3	Check air filter (See Pub. No. RM617E on page EM-1).
----------	---

NG

Repair or replace.

OK

4	Check fuel quality.
----------	----------------------------

CHECK:

- Check that use only diesel fuel.
- Check that the fuel does not contain any impurity.

NG

Replace fuel.

OK

5 Check engine oil (See Pub. No. RM617E on page LU-1).

NG

Add or replace.

OK

6 Check coolant (See Pub. No. RM617E on page CO-1).

NG

Replace coolant.

OK

7 Check injection timing (See Pub. No. RM617E on page EM-14).

NG

Adjusting injection timing.

OK

8 Check idle speed and maximum speed (See Pub. No. RM617E on page EM-17).

NG

Repair or replace injection pump.

OK

9 Check diagnostic connector (DLC3) circuit (See Pub. No. RM617E on page DI-100).

NG

Repair or replace.

OK

10 Check vacuum pump (See Pub. No. RM617E on page EC-3).

NG

Repair or replace.

OK

Proceed to problem symptoms table on [page DI-21](#).

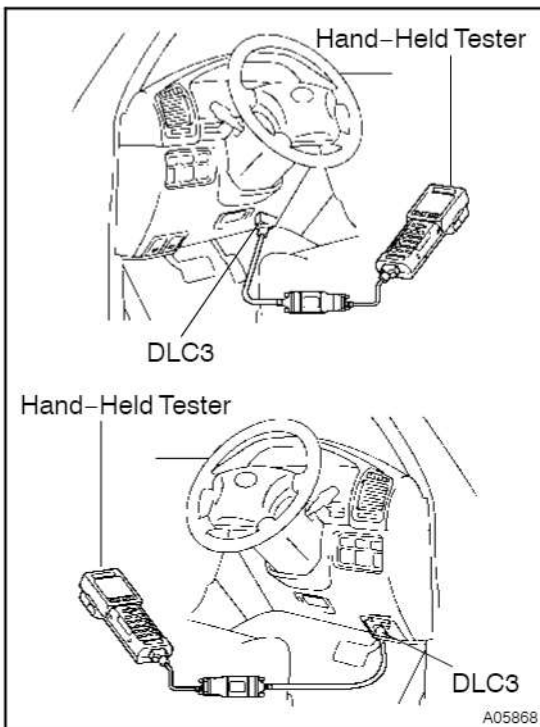

7. REFERENCE VALUE OF ENGINE ECU DATA NOTICE:

The values given below for "Normal Condition" are representative values, so a vehicle may still be normal even if its values from those listed here. So do not decide whether a part is faulty or not solely according to the "Normal Condition" here.

HINT:

Engine engine ECU data can be monitored by hand-held tester.

- (a) Connect the hand-held tester to the DLC3.
- (b) Monitor engine ECU data by following the prompts on the tester screen.

Please refer to the hand-held tester operator's manual for further detail.

(c) Reference Value

Item	Inspection Condition	Reference Value
INJECTION VOLUME	Engine at idling *1	4 - 11 mm ³
	Engine racing at 2,000 rpm *1	4 - 12 mm ³
	Engine racing at 3,000 rpm *1	7 - 14 mm ³
INJECTION TIMING	Engine at idling *1	17 - 21° CA
	Engine racing at 2,000 rpm *1	17 - 24° CA
	Engine racing at 3,000 rpm *1	22.0 - 27° CA
ENGINE SPD	RPM kept stable (Comparison with tachometer)	No great changes
PIM	Engine at idling *1	90 - 110 kPa (675-825 mmHg, 26.6-32.5 in.Hg)
	Engine racing at 2,000 rpm *1	100 - 130 kPa
	Engine racing at 3,000 rpm *1	110 - 130 kPa
COOLANT TEMP	Engine at normal operating temp.	75 - 95°C (167 - 203°F) *2
INTAKE AIR	Engine at normal operating temp.	Ambient temp. - 140°C
FUEL TEMP	Engine at normal operating temp.	Ambient temp. - 65°C
ACCELE POSITION	Accelerator pedal fully closed	0 - 20 %
	Accelerator pedal fully opened	59 - 100 %
	From closed position to wide open accelerator pedal	Gradually increases
VEHICLE SPD	During driving (Comparison with speed meter)	No large differences
A/C SIG	A/C switch ON	ON
IDL SIG	Accelerator pedal full closed	ON
STARTER SIG	During cranking	ON
A/C CUT SIG	A/C switch OFF	ON
EGR SYSTEM	Idling	ON
NSW *3	Neutral start switch signal	P or N position : ON
PS OIL PRESS SW	Power steering oil pressure switch signal	Turn steering wheel : ON
ACCEL CLOSE SW	Accelerator pedal fully closed	ON

*1: All accessories and A/C are switched OFF.

*2: If the water temp. sensor circuit is open or shorted, the engine ECU.

*3: A/T only

DIAGNOSTIC TROUBLE CODE CHART

HINT:

Parameters listed in the chart may not be exactly the same as you reading due to the type of instrument or other factors.

If a malfunction code is displayed during the DTC check in check(test) mode, check the circuit for that code listed in the table below. For details of each code, turn to the page referred to under the "See Page" for the respective "DTC No." in the DTC chart.

DTC No. (See Page)	Detection Item	Trouble Area	*1 Check Engine Warning Light (Normal Mode/ Test Mode)	*2 Memory
12 (★)	Crankshaft Position Sensor Circuit Malfunction	<ul style="list-style-type: none"> • Open or short in crankshaft position sensor circuit • Crankshaft position sensor • Engine ECU 	ON/ON	○
13 (★)	Engine Speed Sensor Circuit Malfunction	<ul style="list-style-type: none"> • Open or short in engine speed sensor circuit • Engine speed sensor • Open or short in STA circuit • Engine ECU 	ON/ON	○
14 (★)	Timing Control System Malfunction	<ul style="list-style-type: none"> • Open or short in timing control valve circuit • Fuel filter (Clogging) • Fuel (Freezing, Air in) • Injection pump (Internal pressure and timing control valve) • Engine ECU 	ON/N.A.	○
15 (DI-23)	Throttle Control Motor Circuit Malfunction	<ul style="list-style-type: none"> • Open or short in throttle control motor circuit • Throttle control motor • Throttle valve • Engine ECU 	ON/N.A.	○
17 (★)	Interior IC Malfunction	<ul style="list-style-type: none"> • Engine ECU 	ON/N.A.	○
19(1) (★)	Accelerator Pedal Position Sensor Circuit Malfunction (Open/Short)	<ul style="list-style-type: none"> • Open or short in accelerator pedal position sensor circuit • Accelerator pedal position sensor • Engine ECU 	ON/ON	○
19(2) (★)	Accelerator Pedal Position Sensor Circuit Malfunction (IDL Switch / Range)	<ul style="list-style-type: none"> • Open or short in accelerator pedal position sensor circuit • Accelerator pedal position sensor • Engine ECU 	ON/ON	○
19(3) (★)	Accelerator Pedal Closed Posi- tion Switch Circuit Malfunction (Short)	<ul style="list-style-type: none"> • Short in accelerator pedal closed position switch circuit • Accelerator pedal closed position switch • Engine ECU 	ON/ON	○
19(4) (★)	Accelerator Pedal Closed Posi- tion Switch Circuit Malfunction (Open)	<ul style="list-style-type: none"> • Open in accelerator pedal closed position switch circuit • Accelerator pedal closed position switch • Engine ECU 	ON/ON	○
22 (★)	Water Temp. Sensor Circuit Malfunction	<ul style="list-style-type: none"> • Open or short in water temp. sensor circuit • Water temp. sensor • Engine ECU 	ON/ON	○
24(1) (★)	Intake Air Temp. Sensor Circuit Malfunction	<ul style="list-style-type: none"> • Open or short in intake air temp. sensor circuit • Intake air temp. sensor • Engine ECU 	OFF/ON	○
24(2) (DI-26)	Atmospheric Temp. Sensor Cir- cuit Malfunction	<ul style="list-style-type: none"> • Open or short in intake air temp. sensor circuit • Atmospheric temp. sensor (built into air flow meter) • Engine ECU 	OFF/ON	○

DIAGNOSTICS - ENGINE (European Spec.)

DTC No. (See Page)	Detection Item	Trouble Area	*1 Check Engine Warning Light (Normal Mode/ Test Mode)	*2 Memory
31 (DI-31)	Air Flow Circuit Malfunction	<ul style="list-style-type: none"> • Open or short in air flow meter circuit • Air flow meter • Engine ECU 	ON/N.A.	○
32 (★)	Injection Pump System Malfunction	<ul style="list-style-type: none"> • Open or short in injection pump correction unit circuit • Injection pump correction unit • Engine ECU 	OFF/N.A.	○
34 (2) (DI-38)	Turbocharger system malfunction	<ul style="list-style-type: none"> • Turbocharger • EGR valve • Air flow meter • Engine ECU 	ON/N.A.	○
34 (3) (DI-38)	Turbocharger stick detected (Close)	<ul style="list-style-type: none"> • Turbocharger • EGR valve • Air flow meter • Engine ECU 	ON/N.A.	○
34 (4) (DI-38)	Turbocharger stick detected (Open)	<ul style="list-style-type: none"> • Turbocharger • EGR valve • Air flow meter • Engine ECU 	ON/N.A.	○
35 (★)	Turbo Pressure Sensor Circuit Malfunction	<ul style="list-style-type: none"> • Open or short in turbo pressure sensor circuit • Turbo pressure sensor • Engine ECU 	ON/ON	○
39 (★)	Fuel Temp. Sensor Circuit Malfunction	<ul style="list-style-type: none"> • Open or short in fuel temp. sensor circuit • Fuel pressure sensor • Engine ECU 	ON/ON	○
42 (★)	Vehicle Speed Sensor Signal Circuit Malfunction	<ul style="list-style-type: none"> • Open or short in vehicle speed sensor circuit • Vehicle speed sensor • Combination meter • Engine ECU 	OFF/ON	○
58 (DI-45)	SCV stick detected (closed)	<ul style="list-style-type: none"> • Turbocharger • EGR valve • Air flow meter • Engine ECU 	ON/ON	○
89	Interior IC Malfunction	<ul style="list-style-type: none"> • Engine ECU 	ON/N.A.	○
97 (★)	EDU Circuit Malfunction	<ul style="list-style-type: none"> • Open or short in EDU circuit • Spill control valve • EDU 	ON/N.A.	○
*3 99	Engine Immobilizer System Malfunction	<ul style="list-style-type: none"> • Open or short in engine immobilizer system circuit • Transponder key amplifier • Transponder key computer • Transponder key coil • Engine ECU 	OFF/ON	○

*1: "ON" displayed in the diagnosis mode column indicates that the check engine warning light is lighted up when a malfunction is detected. "OFF" indicates that the "CHECK ENGINE" does not light up during malfunction diagnosis, even if a malfunction is detected. "N.A." indicates that the item is not included in malfunction diagnosis.

*2: "○" in the memory column indicates that a diagnostic trouble code is recorded in the engine ECU memory when a malfunction occurs. Accordingly, output of diagnostic results in normal or test mode is done with the IG switch ON.

*3: See Pub. No. RM616E BE section.

★: See Pub. No. RM617E

PARTS LOCATION

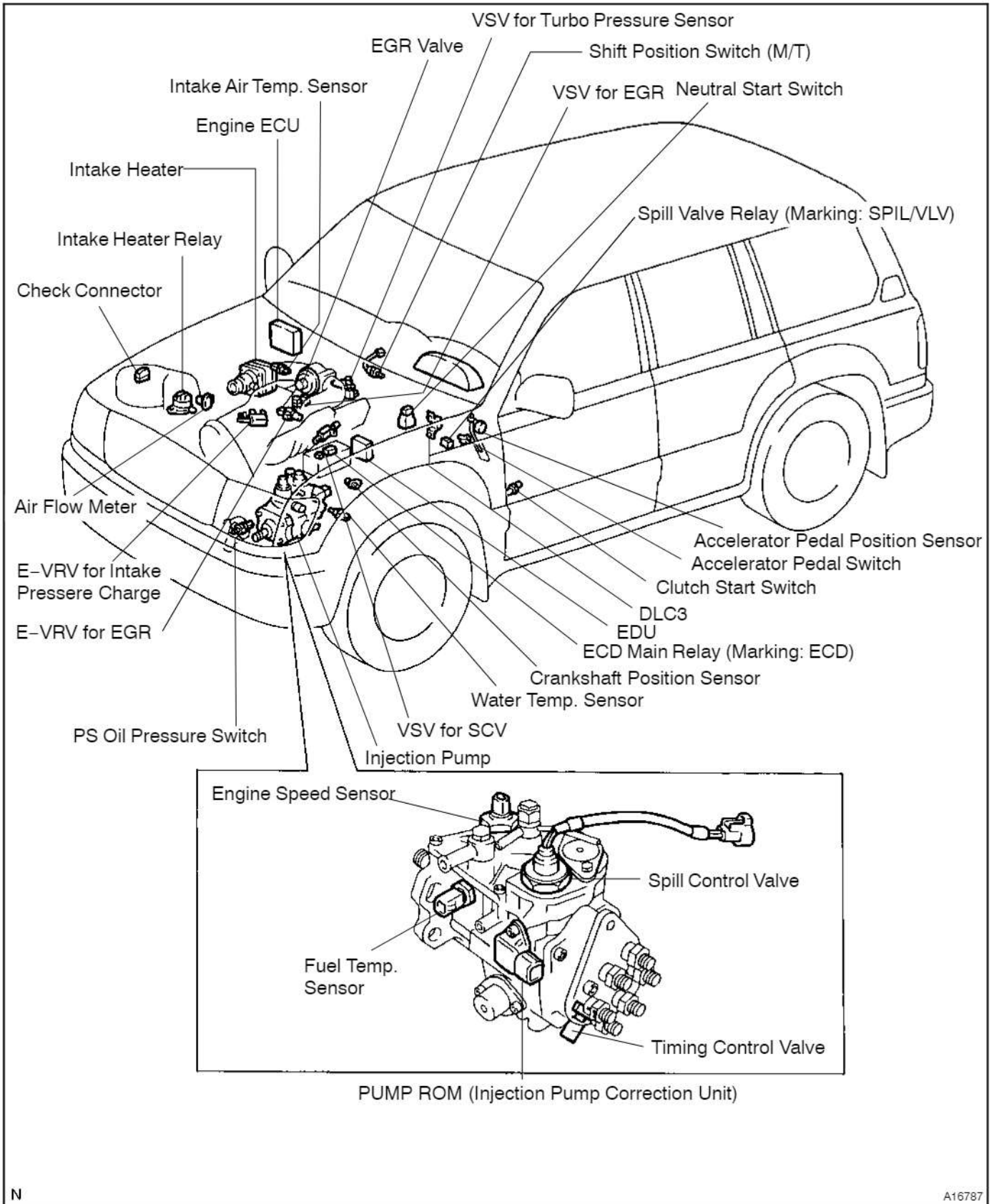

TERMINALS OF ECU

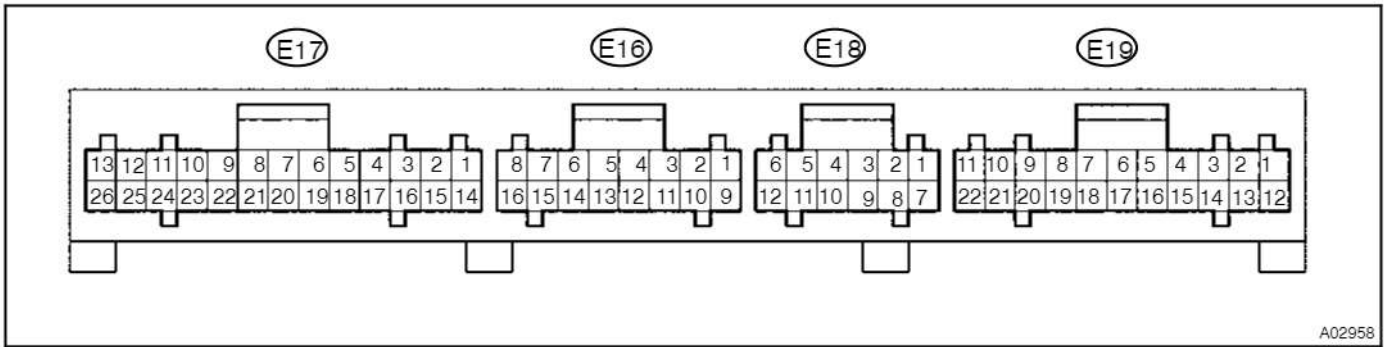

A02958

Symbols (Terminals No.)	Wiring Color	Condition	STD Voltage (V)
BATT (E19-1) – E1 (E17-14)	B-R – BR	Always	9 – 14
+ B (E19-12) – E1 (E17-14)	B-Y – BR	IG switch ON	9 – 14
VC (E16-1) – E2 (E16-9)	L-R – BR-W	IG switch ON	4.5 – 5.5
VCC (E18-6) – E2C (E18-4)	L-R – BR-W	IG switch ON	4.5 – 5.5
VA (E18-5) – E2C (E18-4)	R-Y – BR-W	Accelerator pedal fully closed	0.6 – 1.3
		Accelerator pedal fully opened	2.8 – 4.5
VAS (E18-12) – E2C (E18-4)	P-L – BR-W	Accelerator pedal fully closed	0.6 – 1.3
		Accelerator pedal fully opened	2.8 – 4.5
IDL (E18-9) – E2C (E18-4)	LG-B – BR-W	Accelerator pedal fully closed	9 – 14
		Accelerator pedal fully opened	0 – 3
PIM (E16-2) – E2 (E16-9)	P-L – BR-W	Apply vacuum 40 kPa (300 mmHg, 11.8 in.Hg)	1.0 – 1.8
		Apply vacuum 135 kPa (1,000 mmHg, 39.4 in.Hg)	2.3 – 3.2
THOP (E16-15) – E1 (E17-14)	GR – BR	Accelerator pedal fully closed	9 – 14
		Accelerator pedal fully Opened	0 – 3
THAF (E18-11) – E2 (E16-9)	Y-B – BR-W	Atmospheric temp	0.2 – 3.8
THA (E16-3) – E2 (E16-9)	W-G – BR-W	Idling, air intake temp. 0°C (32°F) to 60°C (140°F)	0.2 – 3.8
THW (E16-4) – E2 (E16-9)	G-B – BR-W	Idling, engine coolant temp. 60°C (140°F) to 120°C (248°F)	0 – 1.2
THF (E16-5) – E2 (E16-9)	G-R – BR-W	IG switch ON (at engine cold)	1.5 – 3.4
VG (E16-10) – EVG (E16-11)	V-R – B	Idling, A/C switch OFF	0.2 – 4.9
STA (E19-11) – E1 (E17-14)	B-R – BR	Cranking	6.0 or more
TDC+ (E17-17) – TDC- (E17-16)	B – W	Idling	Pulse generation (See Pub. No. RM617E on page DI-21)
NE+ (E17-19) – NE- (E17-18)	L – G	Idling	Pulse generation (See Pub. No. RM617E on page DI-21)
SP1 (E19-9) – E1 (E17-14)	V – BR	IG switch ON Rotate driving wheel slowly	Pulse generation
VNT (E17-20) – E01 (E17-13)	B – W-B	IG switch ON	9 – 14
		Idling	Pulse generation (See page DI-38)
TCV (E17-11) – E01 (E17-13)	R-Y – W-B	IG switch ON	9 – 14
		Idling	Pulse generation (See Pub. No. RM617E on page DI-24)
SPVD (E17-12) – E1(E17-14)	L-Y – BR	IG switch ON	9 – 14

DIAGNOSTICS - ENGINE (European Spec.)

SPVF (E17-25) - E1 (E17-14)	L-R - BR	Idling	Pulse generation (See Pub. No. RM617E on page DI-71)
EGR (E17-24) - E01 (E17-13)	R-G - W-B	IG switch ON	9 - 14
		EGR ON	Pulse generation (See Pub. No. RM617E on page DI-85)
PA (E16-16) - E01 (E17-13)	W-R - W-B	VSV for atmospheric pressure leaning OFF	9 - 14
		VSV for atmospheric pressure leaning ON	0 - 3
MREL (E19-3) - E01 (E17-13)	B-W - W-B	IG switch ON	9 - 14
IGSW (E19-14) - E1 (E17-14)	B-R - BR	IG switch ON	9 - 14
AC1 (E18-2) - E1 (E17-14)	W-G - BR	A/C switch ON (at idling)	0 - 1.5
		A/C switch OFF	9 - 14
ACT (E18-8) - E1 (E17-14)	L-B - BR	IG switch ON	9 - 14
		At A/C cut controlled (Driving below 30 km/h, accelerator pedal fully opened for 5 sec.)	0 - 3
PDL (E18-3) - E1 (E17-14)	GR - BR	Accelerator pedal fully closed	9 - 14
		Accelerator pedal fully opened	0 - 3
TAC (E18-7) - E1 (E17-14)	B - BR	Idling	Pulse generation
TC (E19-4) - E1 (E17-14)	P-B - BR	IG switch ON	9 - 14
W (E19-5) - E1 (E17-14)	W - BR	Check engine warning light lights up	0 - 3
		Except check engine warning light lights up	9 - 14
GIND (E18-1) - E1 (E17-14)	Y-R - BR	Glow indicator light lights up	0 - 3
		Except glow indicator light lights up	9 - 14
DATA (E16-6) - E1 (E17-14)	LG - BR	For 0.5 sec. after IG switch ON	Pulse generation
CLK (E16-14) - E1 (E17-14)	L - BR	For 0.5 sec. after IG switch ON	Pulse generation
THWO (E19-8) - E1 (E17-14)	Y-B - BR	IG switch ON	Pulse generation (See Pub. No. RM617E on page DI-96)
LU+A (E17-10) - E1 (E17-14)	G-R - BR	IG switch ON	Pulse generation
LU-A (E17-9) - E1 (E17-14)	G-W - BR	IG switch ON	Pulse generation
LU+B (E17-8) - E1 (E17-14)	V - BR	IG switch ON	Pulse generation
LU-B (E17-7) - E1 (E17-14)	G - BR	IG switch ON	Pulse generation
EGRC (E17-3) - E1 (E17-14)	R - BR	IG switch ON	9 - 14
		Maintain engine speed at 1500 rpm after warming up	0 - 3
SREL (E19-2) - E1 (E17-14)	G-Y - BR	When more than 20 sec. passes after IG switch is turned ON	0 - 3
		At intake heater ON	9 - 14
SPVD (E17-12) - E1 (E17-14)	L-Y - BR	Idling	Pulse generation (See Pub. No. RM617E on page DI-71)
VCH (E17-23) - E1 (E17-14)	Y-R - BR	Heater blower switch ON	9 - 14
		Heater blower switch OFF	0 - 3
SVR (E19-13) - E1 (E17-14)	L-W - BR	IG switch ON	9 - 14

VCT (E16-7) – E1 (E17-14)	L-B – BR	Heater blower switch ON	0 – 3
		Heater blower switch OFF	9 – 14
HSW (E19-20) – E1 (E17-14)	B-L – BR	Push on power heater switch	0 – 3
		Push off power heater switch	9 – 14
FSW (E17-5) – E1 (E17-14)	R-L – BR	At shift position in first position	9 – 14
		At other shift position in first position	0 – 3
PS (E16-8) – E1 (E17-14)	P – BR	Idling, Turn steering wheel	0 – 3
		IG switch ON	9 – 14
SIL (E19-15) – E1 (E17-14)	V-W – BR	Connect hand-held tester to DLC3	Pulse generation
IMI (E19-17) – E1 (E17-14)	L-B – BR	Idling	Pulse generation
IMO (E19-6) – E1 (E17-14)	L-R – BR	A few sec. after engine starting	Pulse generation

PROBLEM SYMPTOMS TABLE

When the malfunction code is not confirmed the DTC check and the problem still can not be confirmed in the basic inspection, then proceed to this step and perform troubleshooting according to the numbered order given in the table below.

Symptom	Suspect Area	See page
Does not crank (Difficult to start)	1. Starter 2. Starter relay 3. Neutral start switch circuit (A/T)	★ ★ ★
Cold engine (Difficult to start)	1. Intake heater control circuit 2. STA signal circuit 3. Heater idle-up switch circuit 4. Injection nozzle 5. Fuel filter 6. Engine ECU 7. Injection pump	★ ★ ★ FU-1 ★ ED-11 ★
Hot engine (Difficult to start)	1. STA signal circuit 2. Injection nozzle 3. Fuel filter 4. Compression 5. Engine ECU 6. Injection pump	★ FU-1 ★ ★ ED-11 ★
Soon after starting (Engine stall)	1. Fuel filter 2. ECU power source circuit 3. Engine ECU 4. Injection pump	★ ★ ED-11 ★
Others (Engine stall)	1. ECU power source circuit 2. Spill valve relay circuit 3. Engine ECU 4. Injection pump	★ ★ ED-11 ★
Incorrect first idle (Poor idling)	1. Fuel filter 2. Engine ECU 3. Injection pump	★ ED-11 ★
High engine idle speed (Poor idling)	1. A/C signal circuit 2. STA signal circuit 3. Engine ECU 4. Injection pump	★ ★ ED-11 ★
Lower engine idle speed (Poor idling)	1. A/C signal circuit 2. Injection nozzle 3. EGR control circuit 4. Compression 5. Valve clearance 6. Fuel line (Air bead) 7. Engine ECU 8. Injection pump	★ FU-1 ★ ★ ★ - ED-11 ★
Rough idling (Poor idling)	1. Injection nozzle 2. Fuel line (Air bead) 3. Intake heater control circuit 4. EGR control circuit 5. Compression 6. Valve clearance 7. Engine ECU 8. Injection pump	FU-1 - ★ ★ ★ ★ ED-11 ★

Symptom	Suspect Area	See page
Hunting at hot engine (Poor idling)	<ol style="list-style-type: none"> 1. Injection nozzle 2. ECU power source circuit 3. Compression 4. Fuel line (Air bead) 5. Valve clearance 6. Engine ECU 7. Injection pump 	FU-1 ★ ★ – ★ ED-11 ★
Hunting at cold engine (Poor idling)	<ol style="list-style-type: none"> 1. Injection nozzle 2. ECU power source circuit 3. Intake heater control circuit 4. Compression 5. Fuel line (Air bead) 6. Valve clearance 7. Engine ECU 8. Injection pump 	FU-1 ★ ★ ★ – ★ ED-11 ★
Hesitation/ Poor acceleration (Poor driveability)	<ol style="list-style-type: none"> 1. Injection nozzle 2. Fuel filter 3. EGR control circuit 4. Compression 5. Engine ECU 6. Injection pump 	FU-1 ★ ★ ★ ED-11 ★
Knocking (Poor driveability)	<ol style="list-style-type: none"> 1. Injection nozzle 2. EGR control circuit 3. Engine ECU 	FU-1 ★ ED-11
Black smoke (Poor driveability)	<ol style="list-style-type: none"> 1. Injection nozzle 2. EGR control circuit 3. Engine ECU 4. Injection pump 	FU-1 ★ ED-11 ★
White smoke (Poor driveability)	<ol style="list-style-type: none"> 1. EGR control circuit 2. Intake heater control circuit 3. Injection nozzle 4. Fuel filter 5. Engine ECU 6. Injection pump 	★ ★ FU-1 ★ ED-11 ★
Surging/ Hunting (Poor driveability)	<ol style="list-style-type: none"> 1. Injection nozzle 2. Engine ECU 3. Injection pump 	FU-1 ED-11 ★

★: See Pub. No. RM617E

CIRCUIT INSPECTION

DTC	15	Throttle Control Motor Circuit Malfunction
------------	-----------	---

CIRCUIT DESCRIPTION

Throttle control motor is operated by the engine ECU and it opens and closes the throttle valve. The fully opening of the throttle valve is detected by the throttle fully open position switch which is mounted on the throttle body.

If this DTC is stored, the engine ECU shuts down the power for the throttle control motor.

DTC No.	DTC Detection Condition	Trouble Area
15	Open or short in throttle control motor circuit	<ul style="list-style-type: none"> • Open or short in throttle control motor circuit • Throttle control motor • Throttle valve • Throttle drive gear
	Open or short in throttle full switch circuit	<ul style="list-style-type: none"> • Diesel throttle body • Engine ECU

WIRING DIAGRAM

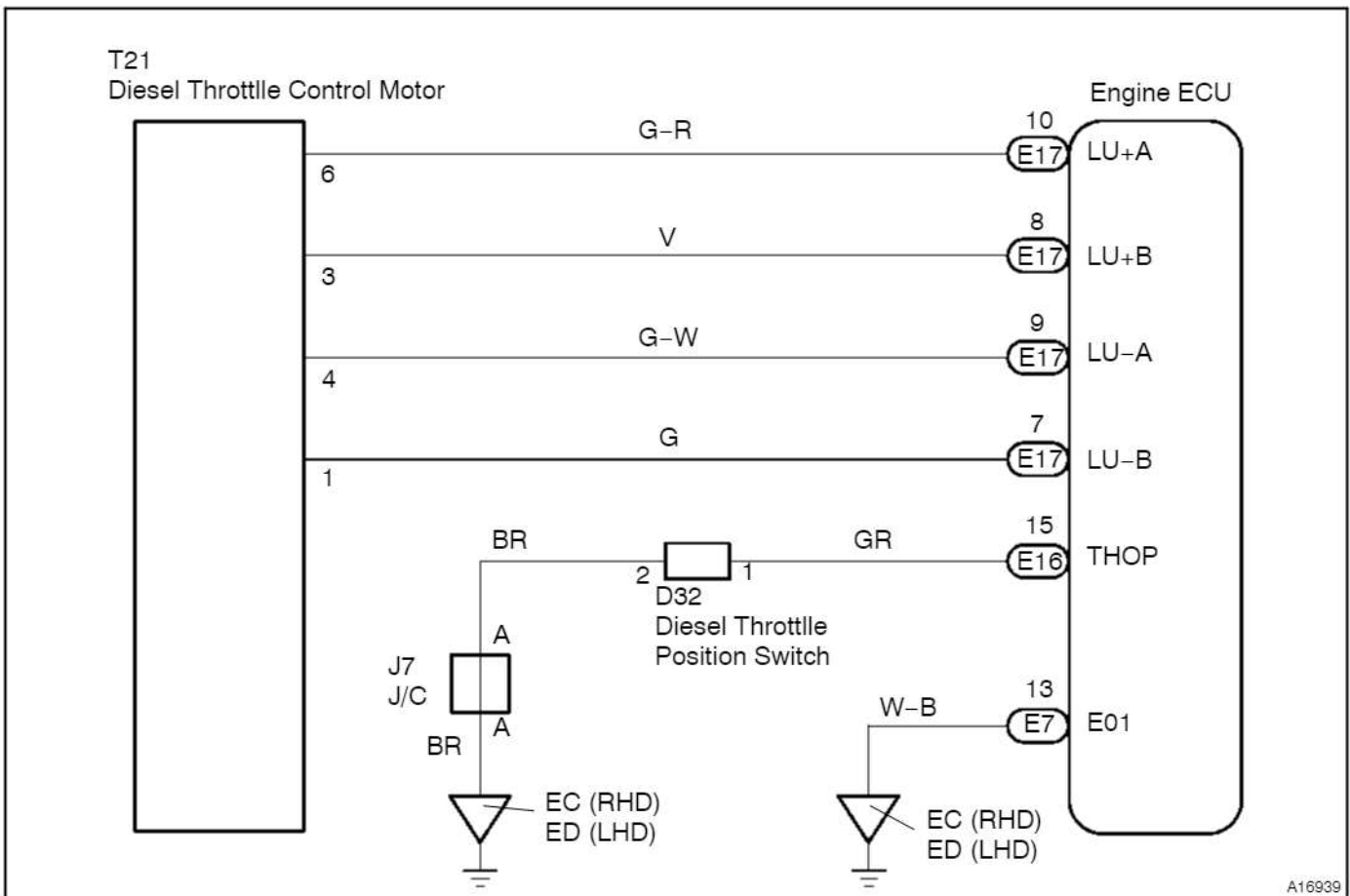

INSPECTION PROCEDURE

HINT:

Read freeze frame data using hand-held tester, as freeze frame records the engine conditions when a malfunction is detected. When troubleshooting, it is useful for determining whether the vehicle was running or stopped, the engine was warmed up or not, etc. at the time of the malfunction.

1 Check throttle control motor circuit.

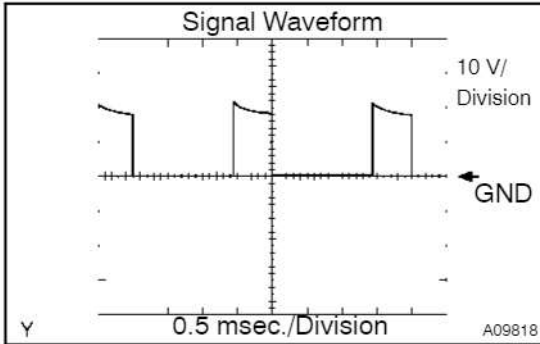

PREPARATION:

- Connect the oscilloscope between terminals LU+A, LU+B, LU-A, LU-B and E01 of the engine ECU.
- Start the engine.

CHECK:

Check the waveform between terminals LU+A, LU+B, LU-A, LU-B and E01 of the engine ECU when the engine is racing.

OK:

The correct waveforms are as shown.

OK

Check and replace engine ECU (See page IN-19).

NG

2 Check throttle control motor.

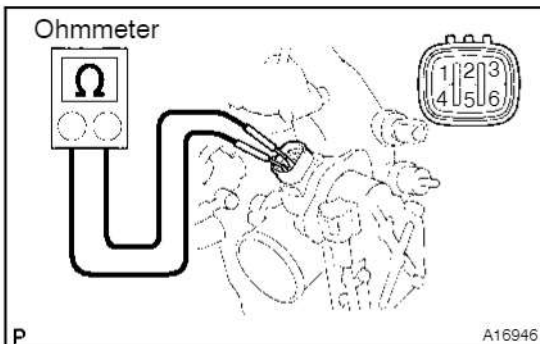

PREPARATION:

Disconnect the throttle control motor connector.

CHECK:

- Measure the resistance between terminals 1, 3 and 2 of the throttle control motor.
- Measure the resistance between terminals 4, 6 and 5 of the throttle control motor.

OK:

Resistance: 18 – 22 Ω at 20°C (68°F)

NG

Replace diesel throttle body assembly (See page ED-1).

OK

3	Check for open and short in harness and connector between throttle control motor and engine ECU (See page IN-19).
----------	--

NG

Repair or replace.

OK

Check and replace engine ECU (See Pub. No. RM617E on page ED-16).

DTC	24 (2)	Atmospheric Temp. Sensor Circuit Malfunction
------------	---------------	---

CIRCUIT DESCRIPTION

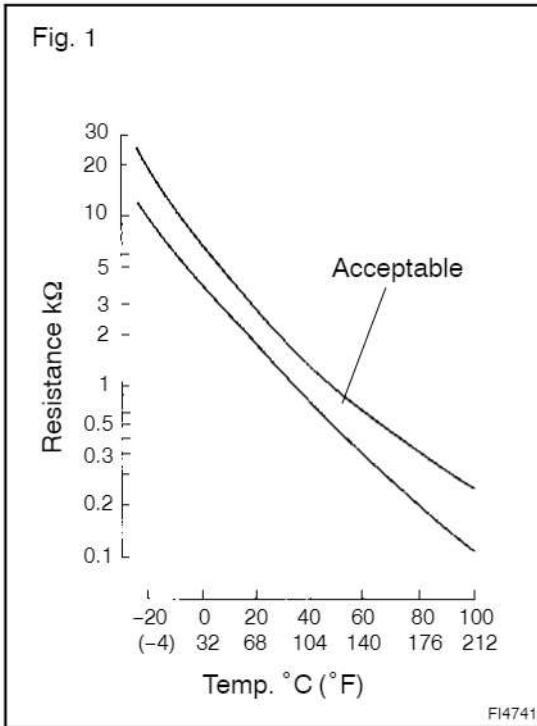

The atmospheric temperature sensor is built into the air flow meter and senses the atmospheric temperature. A thermistor built in the sensor changes the resistance value according to the atmospheric temperature. The lower the atmospheric temperature, the greater the thermistor resistance value, and the higher the atmospheric temperature, the lower the thermistor resistance value (See Fig. 1).

The atmospheric temperature sensor is connected to the engine ECU. The 5 V power source voltage in the engine ECU is applied to the atmospheric temperature sensor from terminal THAF via a resistor R. That is resistor R and the atmospheric temperature sensor are connected in series. When the resistance value of the atmospheric temperature sensor changes. Based on this signal, the engine ECU increases the fuel injection volume to improve drivability during cold engine operation.

DTC No.	DTC Detection Condition	Trouble Area
24	Open or short in atmospheric temp. sensor circuit for 0.5 sec. or more	<ul style="list-style-type: none"> • Open or short in atmospheric temp. sensor circuit • Atmospheric temp. sensor (built into air flow meter) • Engine ECU

HINT:

After confirming DTC 24, use the hand-held tester to confirm the atmospheric temperature from the CURRENT DATA.

Temperature Displayed	Malfunction
-40°C (-40°F)	Open circuit
140°C (284°F) or more	Short circuit

WIRING DIAGRAM

Refer to DTC 31 on [page DI-31](#).

INSPECTION PROCEDURE

HINT:

- If DTC 22, 24, 35 and 39 displays, E2 (sensor ground) may be open.
- Read freeze frame data using hand-held tester, as freeze frame data records the engine conditions when a malfunction is detected. When troubleshooting it is useful for determining whether the vehicle was running or stopped, the engine was warmed up or not, etc. at the time of the malfunction.

When using hand-held tester:

1 Connect hand-held tester, and read value of atmospheric temperature.

PREPARATION:

- Connect the hand-held tester to the DLC3.
- Turn the ignition switch ON and push the hand-held tester main switch ON.

CHECK:

Read the temperature value on the hand-held tester.

OK:

Same as actual atmospheric temperature.

HINT:

- If there is open circuit, hand-held tester indicates -40°C (-40°F).
- If there is short circuit, hand-held tester indicates 140°C (284°F) or more.

NG

-40°C (-40°F) ... Go to step 2.
 140°C (284°F) or more ... Go to step 4.

OK

Check for intermittent problems (See page DI-4).

2 Check for open in harness or engine ECU.

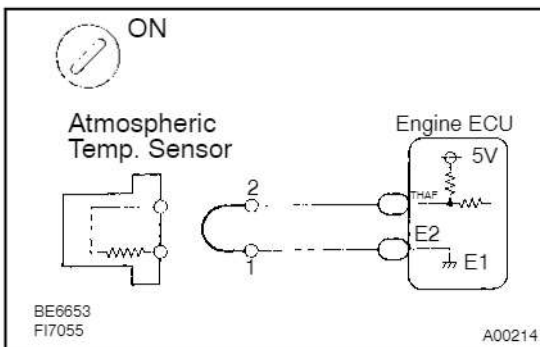

PREPARATION:

- Disconnect the air flow meter connector.
- Connect the sensor wire harness terminals together.
- Turn the ignition switch ON.

CHECK:

Read the temperature value on the hand-held tester.

OK:

Temperature value: 140°C (284°F) or more

OK

Confirm good connection at sensor. If OK, replace air flow meter.

NG

3 Check for open in harness or engine ECU.

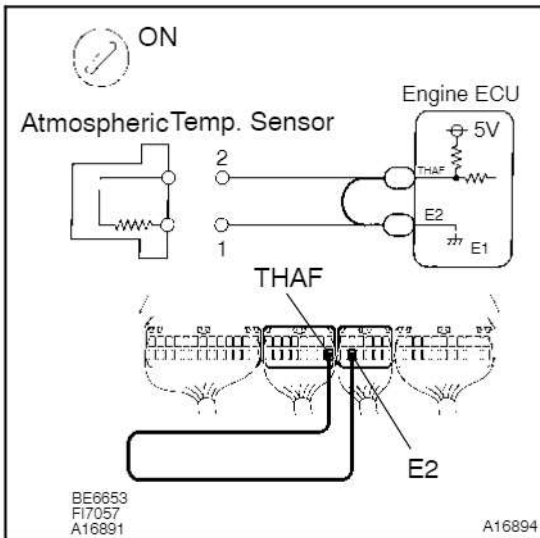

PREPARATION:

- Remove the glove compartment door.
- Connect between terminals THAF and E2 of the engine ECU connector.

HINT:

The air flow meter connector is disconnected. Before checking, do a visual and contact pressure check for the engine ECU connector (See page IN-19).

- Turn the ignition switch ON.

CHECK:

Read the temperature value on the hand-held tester.

OK:

Temperature value: 140°C (284°F) or more

OK

Open in harness between terminal E2 or THAF, repair or replace harness.

NG

Confirm good connection at engine ECU. If OK, replace engine ECU.

4 Check for short in harness and engine ECU.

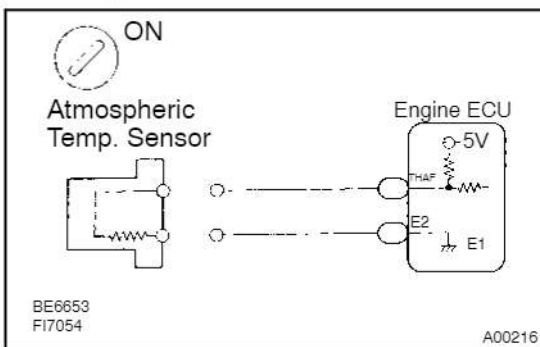

PREPARATION:

- Disconnect the air flow meter connector.
- Turn the ignition switch ON.

CHECK:

Read the temperature value on the hand-held tester.

OK:

Temperature value: -40°C (-40°F)

OK

Replace air flow meter.

NG

5 Check for short in harness or engine ECU.

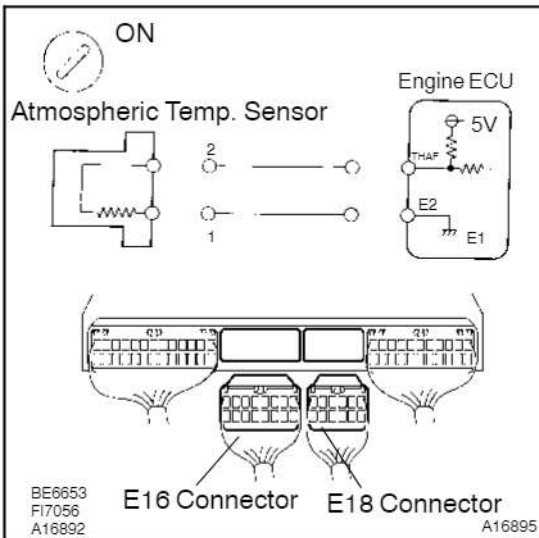

PREPARATION:

- Remove the glove compartment door.
- Disconnect the E6 and E18 connectors from the engine ECU.

HINT:

The air flow meter connector is disconnected.

- Turn the ignition switch ON.

CHECK:

Read the temperature value on the hand-held tester.

OK:

Temperature value: -40°C (-40°F)

OK

Repair or replace harness or connector.

NG

Check and replace engine ECU (See page IN-19).

When not using hand-held tester:

1 Check voltage between terminals THAF and E2 of engine ECU connector.

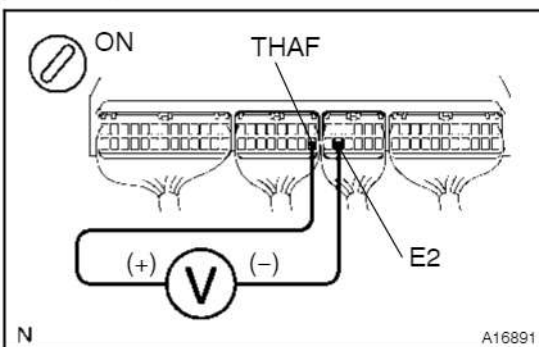

PREPARATION:

- Remove the glove compartment door.
- Turn the ignition switch ON.

CHECK:

Measure the voltage between terminals THAF and E2 of the engine ECU connector.

OK:

Atmospheric Temperature	Voltage
20°C (68°F) (Engine is cool)	0.2 - 3.8 V
80°C (176°F) (Engine is hot)	0.1 - 1.5 V

OK

Check for intermittent problems (See page DI-4).

NG

2 Check atmospheric temperature sensor.

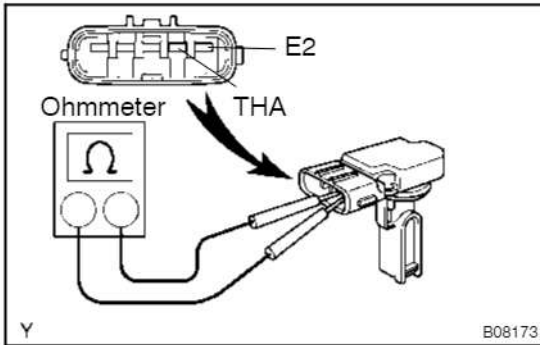

PREPARATION:

Disconnect air flow meter connector.

CHECK:

Using an ohmmeter, measure the resistance between terminals THA and E2.

OK:

Terminals	Resistance	Temperature
THA - E2	12.5 - 16.9 kΩ	-20°C (-4°F)
THA - E2	2.19 - 2.67 kΩ	20°C (68°F)
THA - E2	0.50 - 0.68 kΩ	60°C (140°F)

NG

Replace air flow meter.

OK

3 Check for open and short in harness and connector between engine ECU and atmospheric temperature sensor (See page IN-19).

NG

Repair or replace harness or connector.

OK

Check and replace engine ECU (See page IN-19).

DTC	31	Air Flow Circuit Malfunction
------------	-----------	-------------------------------------

CIRCUIT DESCRIPTION

The air flow meter uses a platinum hot wire. The hot wire air flow meter consists of a platinum hot wire, thermistor and a control circuit installed in a plastic housing. The hot wire air flow meter works on the principle that the hot wire and thermistor located in the intake air bypass of the housing detect any changes in the intake air temperature.

The hot wire is maintained at the set temperature by controlling the current flow through the hot wire. This current flow is then measured as the output voltage of the air flow meter.

The circuit is constructed so that the platinum hot wire and thermistor provide a bridge circuit with the power transistor controlled so that the potential of A and B remains equal to maintain the set temperature.

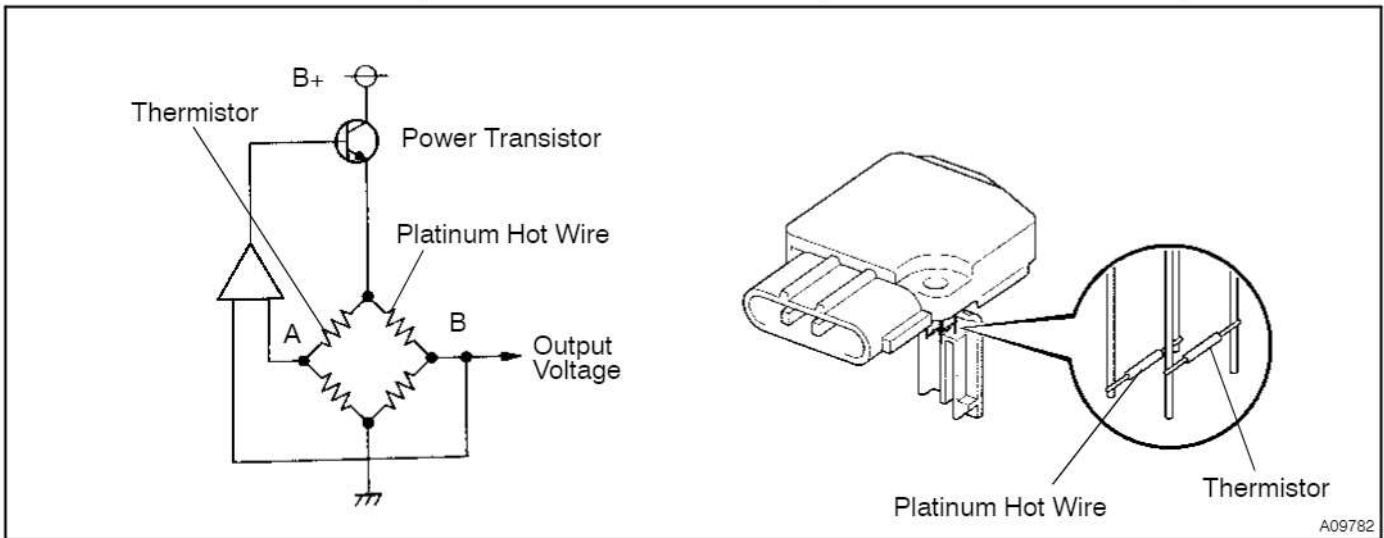

DTC No.	DTC Detection Condition	Trouble Area
31	Open or short in air flow meter circuit with more than 3 sec.	<ul style="list-style-type: none"> • Open or short in air flow meter circuit • Air flow meter • Engine ECU

HINT:

After confirming DTC 31, use the hand-held tester to confirm the air flow ratio from the CURRENT DATA.

Air Flow Value (gm/sec.)	Malfunction
Approx. 0.0	<ul style="list-style-type: none"> • Air flow meter power source circuit open • VG circuit open or short
184.0 or more	<ul style="list-style-type: none"> • EVG circuit open

WIRING DIAGRAM

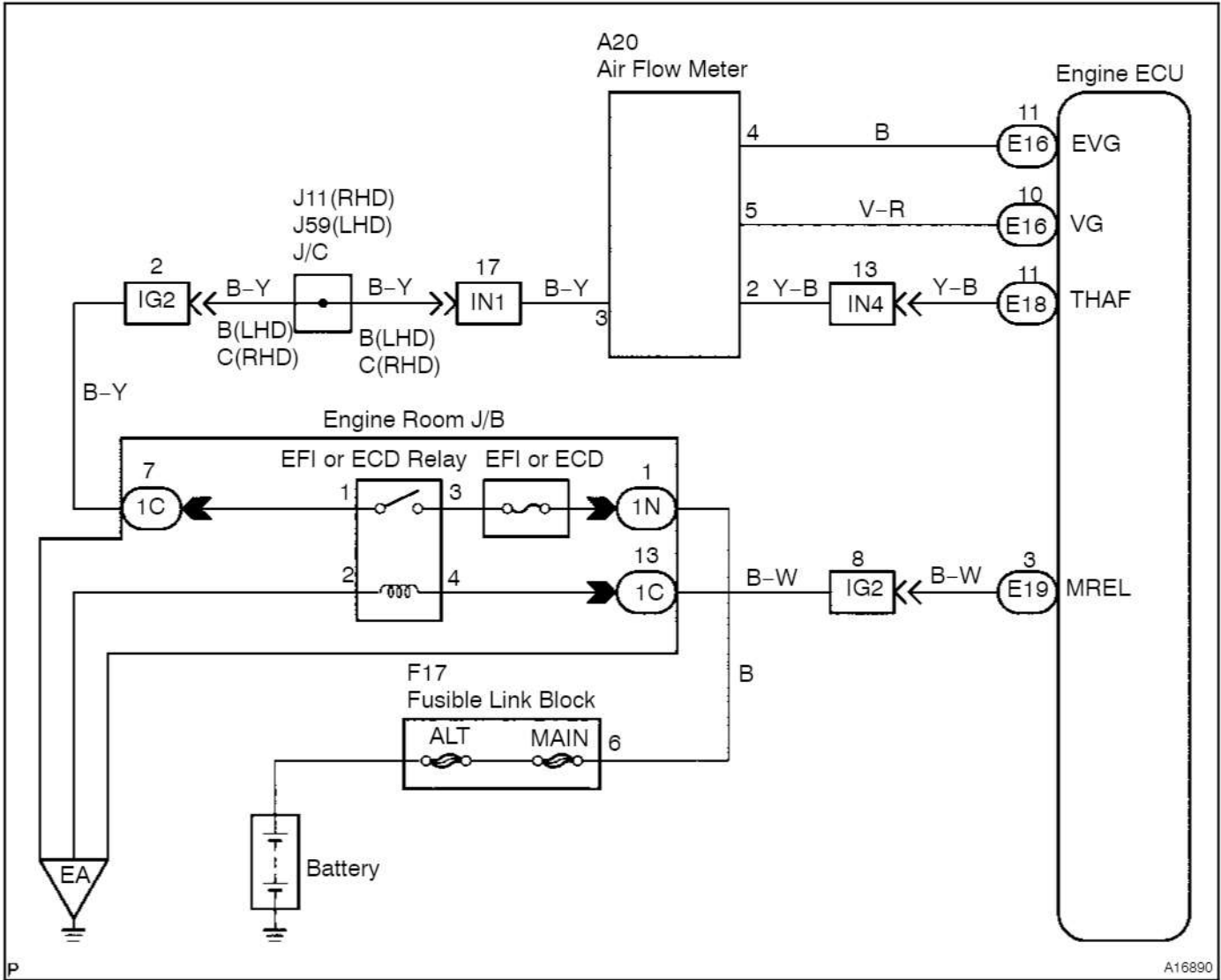

cardiagn.com

INSPECTION PROCEDURE

HINT:

Read freeze frame data using hand-held tester, as freeze frame data records the engine conditions when a malfunction is detected. When troubleshooting, it is useful for determining whether the vehicle was running or stopped, the engine was warmed up or not, etc. at the time of the malfunction.

When using hand-held tester:

1	Connect hand-held tester, and read value of air flow rate.
----------	---

PREPARATION:

- (a) Connect the hand-held tester to the DLC3.
- (b) Turn the ignition switch ON and push the hand-held tester main switch ON.
- (c) Start the engine.

CHECK:

Read the air flow rate on the hand-held tester.

RESULT:

	Type I	Type II
Air Flow Rate (gm/sec.)	0.0	271.0 or more

Type I

Go to step 2.

Type II

Go to step 5.

2	Check voltage of air flow meter power source.
----------	--

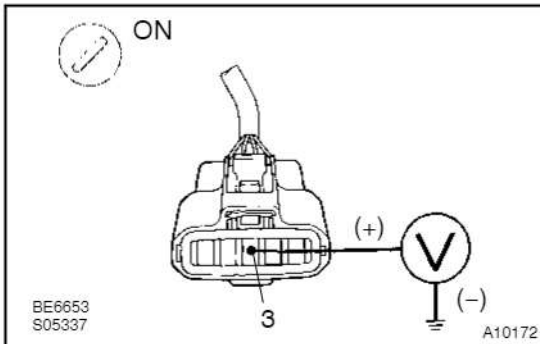

PREPARATION:

- (a) Disconnect the air flow meter connector.
- (b) Turn the ignition switch ON.

CHECK:

Measure the voltage between terminal 3 of the air flow meter connector and body ground.

OK:

Voltage: 9 - 14 V

NG

Check for open in harness and connector between EFI main relay (Marking: EFI) and air flow meter (See page IN-19).

OK

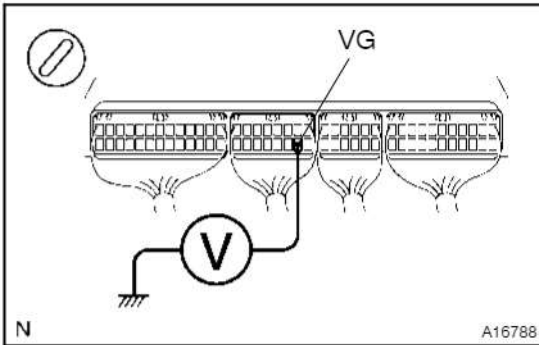
3 Check voltage between terminals VG of engine ECU connector and body ground.
**PREPARATION:**

- (a) Remove the glove compartment door.
- (b) Start the engine.

CHECK:

Measure the voltage between terminal VG of the engine ECU connector and body ground while the engine is idling.

OK:**Voltage:**

0.2 – 4.9 V (Neutral position and A/C switch OFF)

OK

Check and replace engine ECU (See page [IN-19](#)).

NG

4 Check for open and short in harness and connector between air flow meter and engine ECU (See page [IN-19](#)).

NG

Repair or replace harness or connector.

OK

Replace air flow meter.

5 Check continuity between terminal EVG of engine ECU connector and body ground.

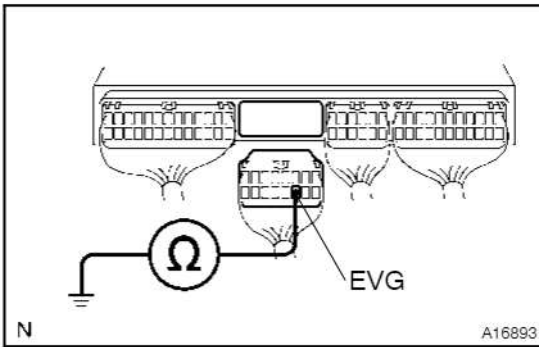

PREPARATION:

- (a) Remove the glove compartment door.
- (b) Disconnect the engine ECU connector.

CHECK:

Check the continuity between terminal EVG of the engine ECU connector and body ground.

OK:

Continuity (1 Ω or less)

OK

Check and replace engine ECU (See page [IN-19](#)).

NG

6 Check for open in harness and connector between air flow meter and engine ECU (See page [IN-19](#)).

NG

Repair or replace harness or connector.

OK

Replace air flow meter.

When not using hand-held tester:

1 Check voltage between terminals VG of engine ECU connector and body ground.

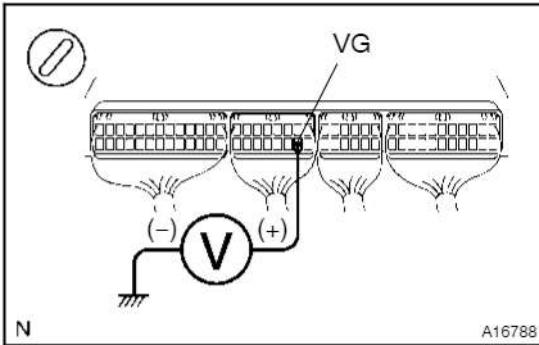
**PREPARATION:**

- (a) Remove the glove compartment door.
- (b) Start the engine.

CHECK:

Measure the voltage between terminal VG of the engine ECU connector and body ground while the engine is idling.

OK:

Voltage:

0.2 – 4.9 V (Neutral position and A/C switch OFF)

OK

Check and replace engine ECU (See page IN-19).

NG

2 Check voltage of air flow meter power source.

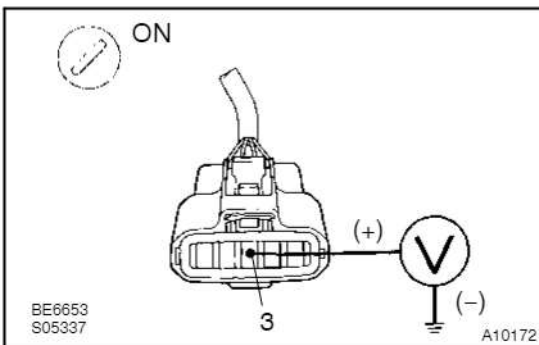
**PREPARATION:**

- (a) Disconnect the air flow meter connector.
- (b) Turn the ignition switch ON.

CHECK:

Measure the voltage between terminal 3 of the air flow meter connector and body ground.

OK:

Voltage: 9 – 14 V

NG

Check for open in harness and connector between EFI main relay (Marking: EFI) and air flow meter (See page IN-19).

OK

3	Check for open in harness and connector between air flow meter and engine ECU (See page IN-19).
----------	--

NG

Repair or replace harness or connector.

OK

Replace air flow meter.

DTC	34 (2)	Turbocharger system malfunction
------------	---------------	--

DTC	34 (3)	Turbocharger stick detected (Close)
------------	---------------	--

DTC	34 (4)	Turbocharger stick detected (Open)
------------	---------------	---

CIRCUIT DESCRIPTION

DTC No.	DTC Detecting Condition	Trouble Area
34 (2)	When the condition that the turbocharger pressure exceeds the standard value for 0.5 sec. or more is detected.	<ul style="list-style-type: none"> • VNT valve • Turbocharger • EGR valve • Air flow meter • Engine ECU
34 (3) (4)	When the condition that for 60 sec. or more the turbocharger pressure is 20 kPa (0.2 kgf/cm ² , 1.4 psi) or more above the value that is set based on the engine revolution and the amount of fuel injection is detected.	

INSPECTION PROCEDURE

HINT:

If DTC 35 is output simultaneously, first troubleshoot DTC 35.

When using hand-held tester:

1	Check connection of vacuum hose.
----------	---

NG

Repair or replace.

OK

- 2 Check vacuum between turbocharger and E-VRV for intake pressure change at 900 rpm.**

PREPARATION:

- (a) Using a 3-way connector, connect a vacuum gauge to the hose between the E-VRV and turbocharger.
 (b) Warm up the engine to above 80°C (176°F).

CHECK:

Check the vacuum at 900 rpm.

RESULT:

Type	Vacuum
I	0 kPa (0 mmHg, in. Hg) - 50 kPa (375 mmHg, 14.8 in. Hg)
II	Above 50 kPa (375 mmHg, 14.8 in. Hg)

Type II Go to step 7.

Type I

- 3 Check voltage between terminal VNT of engine ECU connector and body ground.**

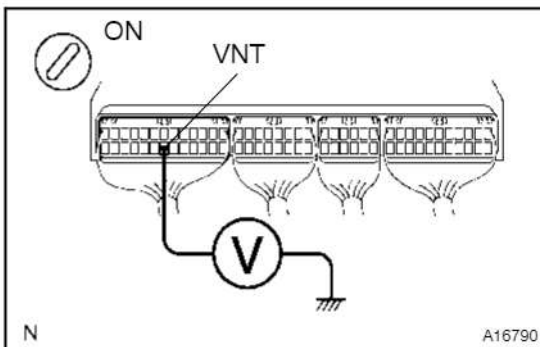
**PREPARATION:**

- (a) Remove the glove compartment door.
 (b) Turn the ignition switch ON.

CHECK:

Measure the voltage between terminal VNT of the engine ECU connector and body ground.

OK:

Voltage: 9 - 14 V

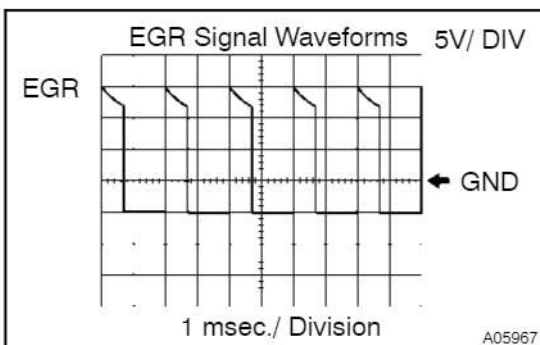
**Reference: INSPECTION USING OSCILLOSCOPE**

During EGR system is ON (engine speed 900 rpm), check the waveform between terminals VNT and E1 of engine ECU connector.

HINT:

The correct waveform is as shown.

NG Go to step 5.

OK

4	Check operation of E-VRV for intake pressure change.
----------	---

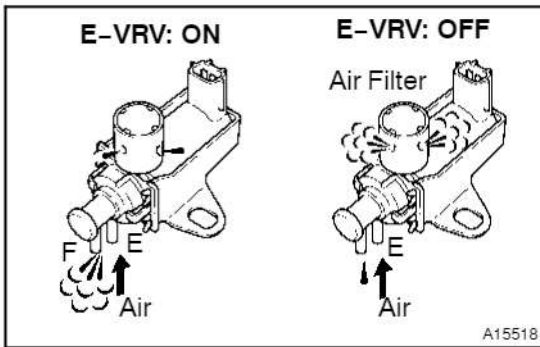
**PREPARATION:**

- Disconnect the vacuum hoses from the E-VRV.
- Connect the hand-held tester to the DLC3.
- Turn the ignition switch ON and the push hand-held tester main switch ON.
- Select the ACTIVE TEST mode on the hand-held tester.

CHECK:

Check the operation of the E-VRV when it is operated by the hand-held tester.

OK:

E-VRV ON:

Air from port E flows out through port F.

E-VRV OFF:

Air from port E flows out through air filter.

OK

Go to step 7.

NG

5	Check E-VRV for intake pressure change (See page TC-15).
----------	---

NG

Replace E-VRV.

OK

6	Check for open and short in harness and connector between E-VRV and engine ECU, and E-VRV and EFI main relay (Marking : EFI) (See page IN-19).
----------	---

NG

Repair or replace harness or connector.

OK

7 Check turbocharger assembly (See page TC-1).

NG

Replace turbocharger.

OK

8 Check EGR valve (See page EC-2).

NG

Replace EGR valve.

OK

9 Check air flow meter (See page DI-26).

NG

Replace air flow meter.

OK

Check and replace engine ECU (See page IN-19).

When not using hand-held tester:

1 Check the connection of vacuum hose.

NG

Repair or replace.

OK

- | | |
|----------|---|
| 2 | Check vacuum between turbocharger and E-VRV for intake pressure change at 900 rpm. |
|----------|---|

PREPARATION:

- (a) Using a 3-way connector, connect a vacuum gauge to the hose between the E-VRV and turbocharger.
 (b) Warm up the engine to above 80°C (176°F).

CHECK:

Check the vacuum at 900 rpm.

RESULT:

Type	Vacuum
I	0 kPa (0 mmHg, in. Hg) – 50 kPa (375 mmHg, 14.8 in. Hg)
II	Above 50 kPa (375 mmHg, 14.8 in. Hg)

Type II

Go to step 6.

Type I

- | | |
|----------|----------------------------------|
| 3 | Check operation of E-VRV. |
|----------|----------------------------------|

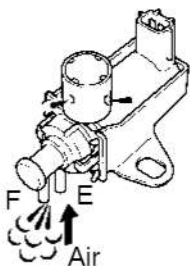
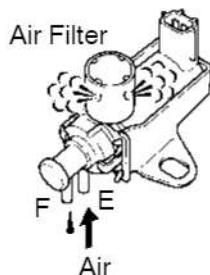
E-VRV: ON**E-VRV: OFF**

A18530

PREPARATION:

- (a) Remove the glove compartment door.
 (b) Disconnect the E3 connector from the engine ECU.
 (c) Turn the ignition switch ON.

CHECK:

Check the E-VRV operation.

- Connect between terminal VNT of the engine ECU connector and body ground (ON).
- Disconnect between terminal VNT of the engine ECU connector and body ground (OFF).

OK:**E-VRV ON:**

Air from port E flows out through port F.

E-VRV OFF:

Air from port E flows out through air filter.

OK

Go to step 6.

NG

4 Check E-VRV for intake pressure change (See page ED-10).

NG

Replace E-VRV.

OK

5 Check for open and short in harness and connector between E-VRV and engine ECU, and E-VRV and EFI main relay (Marking : EFI) (See page IN-19).

NG

Repair or replace harness or connector.

OK

6 Check turbocharger assembly (See page TC-1).

NG

Replace turbocharger.

OK

7 Check EGR valve (See page EC-2).

NG

Replace EGR valve.

OK

8 Check air flow meter (See page DI-26).

NG

Replace air flow meter.

OK

Check and replace engine ECU (See page IN-19).

DTC	58	SCV Stick Detected (Closed)
------------	-----------	------------------------------------

CIRCUIT DESCRIPTION

DTC No.	DTC Detecting Condition	Trouble Area
58	When the condition that the turbocharger pressure exceeds the standard value for 0.5 sec. or more is detected.	<ul style="list-style-type: none"> • SCV valve • VSV for SCV • Engine ECU

INSPECTION PROCEDURE

When using hand-held tester:

1	Check connection of vacuum hose.
----------	---

NG

Repair or replace.

OK

2	Check vacuum between SCV and VSV for SCV at 900 rpm.
----------	---

PREPARATION:

- (a) Using a 3-way connector, connect a vacuum gauge to the hose between the VSV and SCV.
- (b) Warm up the engine to above 80°C (176°F).

CHECK:

Check the vacuum at 900 rpm.

RESULT:

Type	Vacuum
I	0 kPa (0 mmHg, in. Hg) – 50 kPa (375 mmHg, 14.8 in. Hg)
II	Above 50 kPa (375 mmHg, 14.8 in. Hg)

Type II

Go to step 7.

Type I

3 Check voltage between terminal SCV of engine ECU connector and body ground.

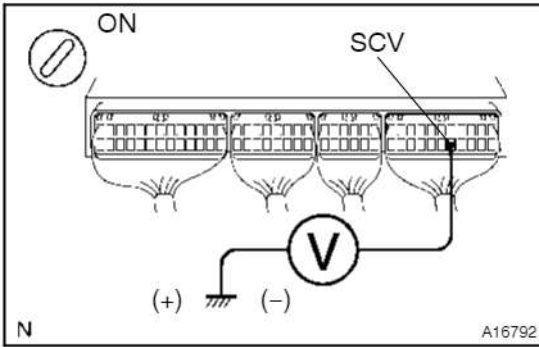

PREPARATION:

- Remove the glove compartment door.
- Turn the ignition switch ON.

CHECK:

Measure the voltage between terminal SCV of the engine ECU connector and body ground.

OK:

Voltage: 9 - 14 V

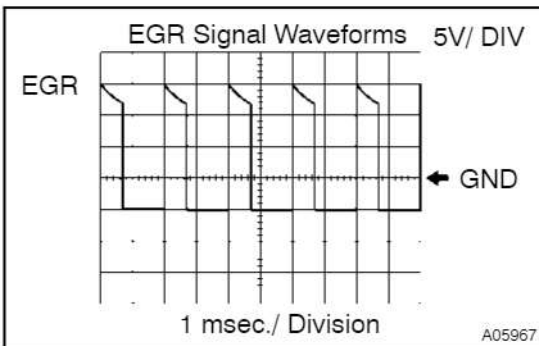

Reference: INSPECTION USING OSCILLOSCOPE

During SCV system is ON (engine speed 900 rpm), check the waveform between terminals SCV and E1 of engine ECU connector.

HINT:

The correct waveform is as shown.

NG

Go to step 5.

OK

4 Check operation of VSV for SCV.

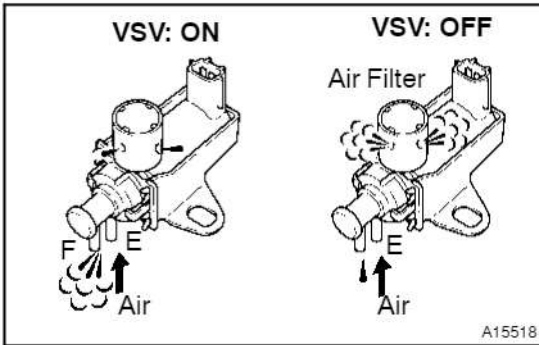

PREPARATION:

- Disconnect the vacuum hoses from the VSV.
- Connect the hand-held tester to the DLC3.
- Turn the ignition switch ON and the push hand-held tester main switch ON.
- Select the ACTIVE TEST mode on the hand-held tester.

CHECK:

Check the operation of the VSV when it is operated by the hand-held tester.

OK:

VSV ON:

Air from port E flows out through port F.

VSV OFF:

Air from port E flows out through air filter.

OK

Go to step 7.

NG

5 Check VSV for SCV (See page ED-10).

NG

Replace VSV.

OK

6 Check for open and short in harness and connector between VSV and engine ECU, and VSV and EFI main relay (Marking : EFI) (See page IN-19).

NG

Repair or replace harness or connector.

OK

7 Check SCV assembly (See page ED-7).

NG

Replace SCV assembly.

OK

Check and replace engine ECU (See page IN-19).

When not using hand-held tester:

1 Check the connection of vacuum hose.

NG

Repair or replace.

OK

2 Check vacuum between turbocharger and VSV for SCV at 900 rpm.

PREPARATION:

- (a) Using a 3-way connector, connect a vacuum gauge to the hose between the VSV and SCV.
- (b) Warm up the engine to above 80°C (176°F).

CHECK:

Check the vacuum at 900 rpm.

RESULT:

Type	Vacuum
I	0 kPa (0 mmHg, in. Hg) – 50 kPa (375 mmHg, 14.8 in. Hg)
II	Above 50 kPa (375 mmHg, 14.8 in. Hg)

Type II

Go to step 6.

Type I

3 Check operation of VSV.

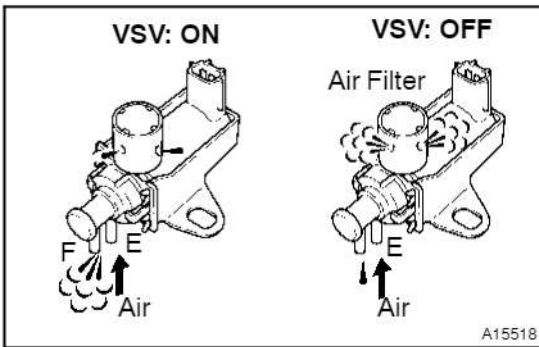

PREPARATION:

- Remove the glove compartment door.
- Disconnect the E3 connector from the engine ECU.
- Turn the ignition switch ON.

CHECK:

Check the VSV operation.

- Connect between terminal SCV of the engine ECU connector and body ground (ON).
- Disconnect between terminal SCV of the engine ECU connector and body ground (OFF).

OK:

VSV ON:

Air from port E flows out through port F.

VSV OFF:

Air from port E flows out through air filter.

OK

Go to step 6.

NG

4 Check VSV for SCV (See page ED-10).

NG

Replace VSV.

OK

5 Check for open and short in harness and connector between VSV and engine ECU, and VSV and EFI main relay (Marking : EFI) (See page IN-19).

NG

Repair or replace harness or connector.

OK

6 Check SCV assembly ([See page ED-7](#)).

NG

Replace SCV assembly.

OK

Check and replace engine ECU ([See page IN-19](#)).

AIR CONDITIONER IDLE-UP SPEED (European Spec.)

EM01W7-02

INSPECTION

1. INITIAL CONDITIONS

- (a) Engine at normal operating temperature.
- (b) Air cleaner installed.
- (c) All pipes and hoses of air induction system connected.
- (d) All accessories switch OFF.
- (e) All vacuum lines properly connected.
- (f) ECD system wiring connectors fully plugged.
- (g) Valve clearance set correctly.
- (h) Injection timing set correctly.
- (i) Idle speed set correctly.

2. CONNECT TACHOMETER

3. INSPECT A/C IDLE-UP SPEED

- (a) Start the engine.
- (b) Push on the A/C switch.
- (c) Check the A/C idle-up speed.

A/C idle-up speed: 775 - 875 rpm

If the A/C idle-up speed is not specified, check the troubleshooting in DI section.

TIMING BELT (European Spec.) COMPONENTS

EM1SV-01

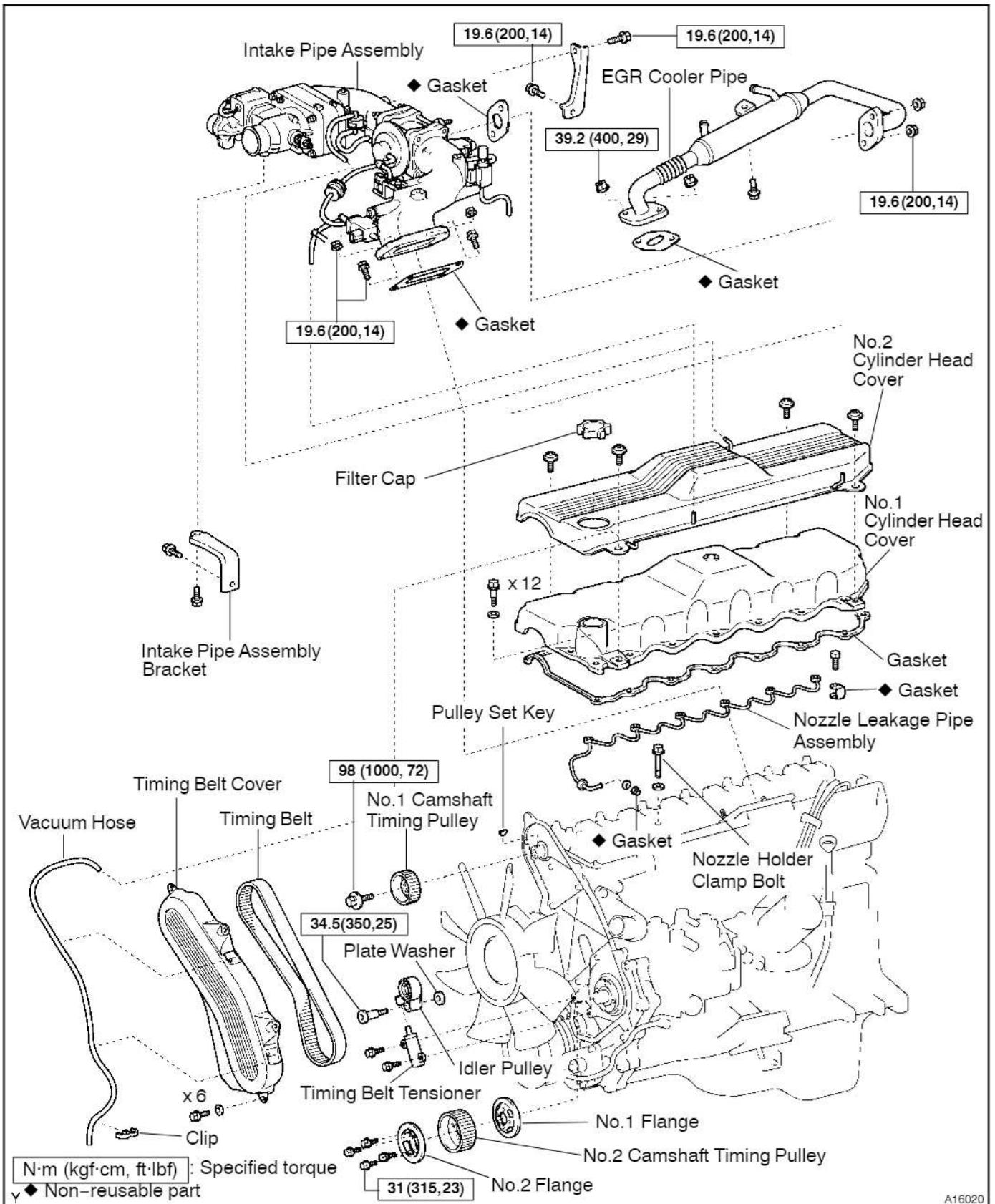

cardiagn.com

A16020

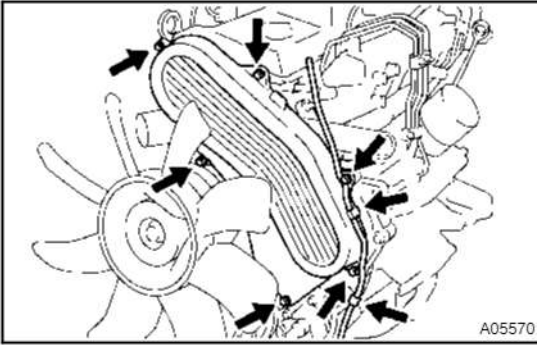

REMOVAL

1. REMOVE INTAKE PIPE ASSEMBLY

(See page EM-23)

2. REMOVE TIMING BELT COVER

- (a) Disconnect the vacuum hose from the timing belt cover and vacuum hose from the clip.
- (b) Remove the 6 bolts, 6 seal washers and timing belt cover.

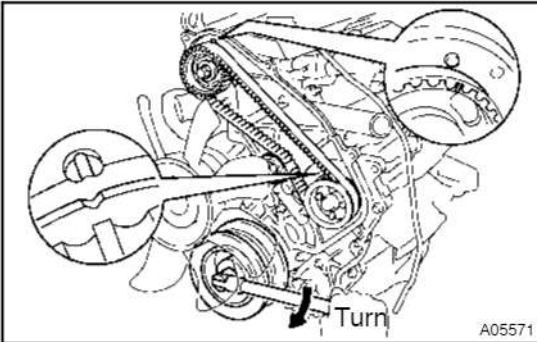

3. SET NO.1 CYLINDER TO BDC/COMPRESSION

Turn the crankshaft pulley clockwise, align the timing marks of the No.1 and No.2 camshaft timing pulleys with the BDC marks.

NOTICE:

If the timing belt is disengaged, having the crankshaft pulley at the wrong angle can cause the piston head and valve head to come into contact with each other when you remove the camshaft timing pulley (step 8), causing damage. so always set the crankshaft pulley at the correct angle.

4. REMOVE TIMING BELT

HINT:

- When re-using timing belt:
Draw a direction arrow on the timing belt (in the direction of engine revolution), and place match-marks on the timing pulleys and timing belt.
- When replacing timing belt tensioner only:
To avoid meshing of the timing pulley and timing belt, secure one of them with the string.

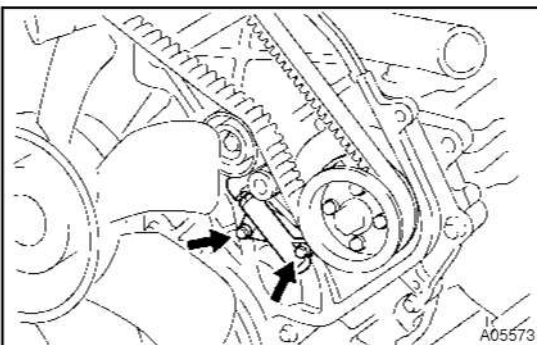
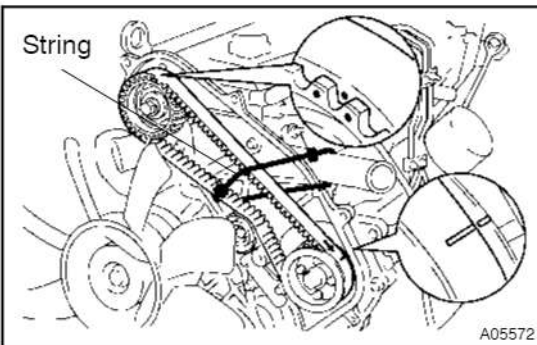

- (a) Alternately loosen the 2 bolts, and remove them and the timing belt tensioner.
- (b) Remove the timing belt.

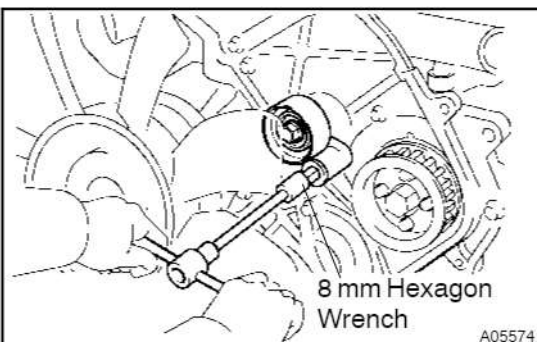

5. REMOVE IDLER PULLEY

Using an 8 mm hexagon wrench, remove the pivot bolt, idler pulley and plate washer.

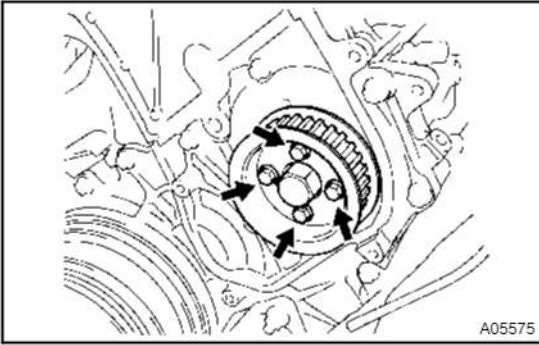
**6. REMOVE NO.2 CAMSHAFT TIMING PULLEY**

Remove the 4 bolts, No.2 flange, timing pulley and No.1 flange.

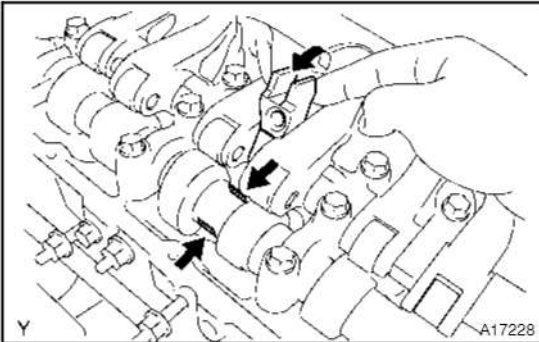
7. REMOVE NO.1 AND NO.2 CYLINDER HEAD COVER
(See page EM-23)**8. REMOVE NO.1 CAMSHAFT TIMING PULLEY**

(a) Remove the nozzle leakage pipe assembly.

(See Pub. No. RM617E, on page FU-33)

(b) Remove the bolt from the 2nd nozzle holder clamp.

(c) Turn the 2nd nozzle holder clamp.

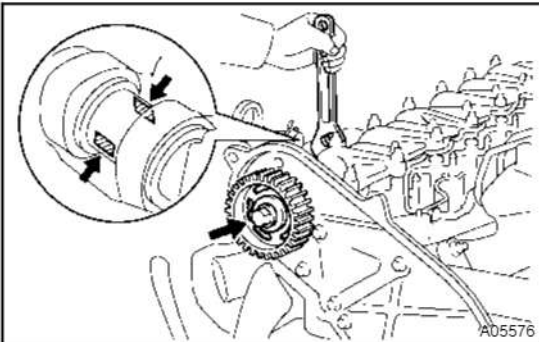

(d) Slightly turn the camshaft timing pulley counterclockwise and hold the hexagon wrench head portion of the camshaft with a wrench, and remove the bolt and timing pulley.

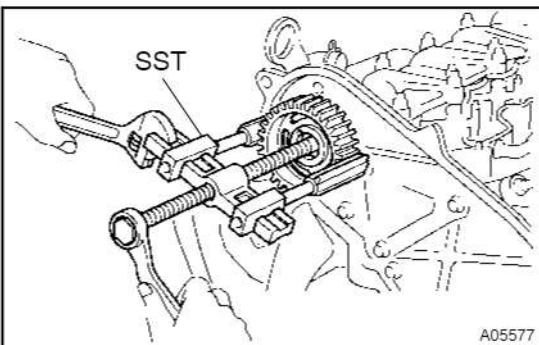

(e) Using SST, remove the timing pulley.

SST 09950-40011 (09951-04010, 09952-04010,
09953-04020, 09954-04010, 09955-04061)

(f) Remove the set key.

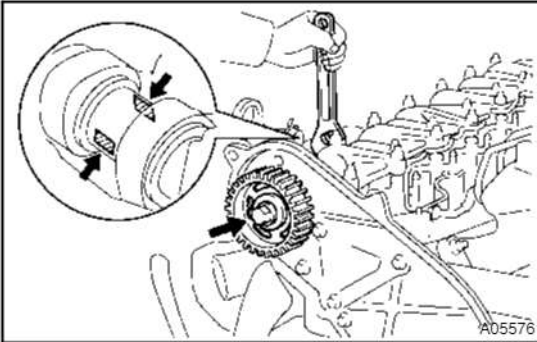

INSTALLATION

1. INSTALL NO.1 CAMSHAFT TIMING PULLEY

- Install the set key to the key groove of the camshaft.
- Align the pulley set key with the key groove of the timing pulley, and slide the timing pulley.
- Temporarily install the pulley bolt.
- Hold the hexagon wrench head portion of the camshaft with a wrench, and tighten the pulley bolt.

Torque: 98 N·m (1,000 kgf·cm, 72 ft·lbf)

- Install the bolt to the 2nd nozzle holder clamp.

Torque: 25 N·m (255 kgf·cm, 18 ft·lbf)

- Install the nozzle leakage pipe assembly.
(See Pub. No. RM617E, on page FU-44)

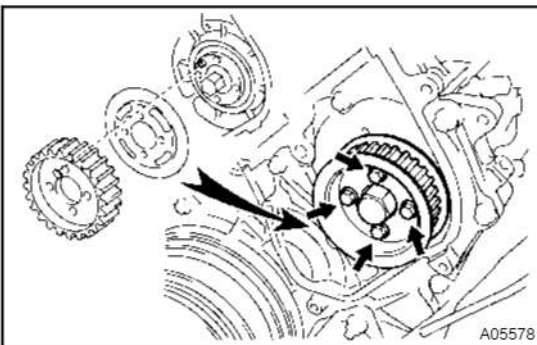

2. INSTALL CYLINDER HEAD COVER

(See page EM-36)

3. INSTALL NO.2 CAMSHAFT TIMING PULLEY

- Align the knock pin on the injection pump drive gear with the knock pin hole of the No.1 flange and the knock pin groove of the timing pulley.
- Install the No.1 flange, timing pulley and No.2 flange with the 4 bolts.

Torque: 31 N·m (315 kgf·cm, 23 ft·lbf)

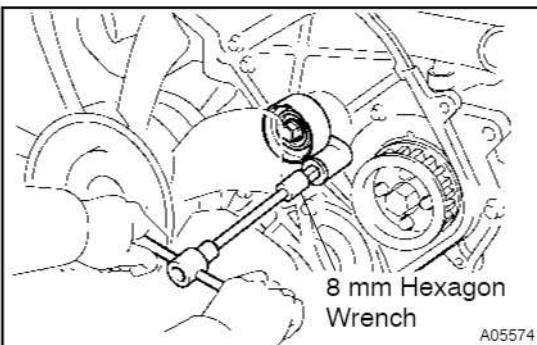

4. INSTALL IDLER PULLEY

- Using an 8 mm hexagon wrench, install the plate washer and idler pulley with the pivot bolt.
- Check that the pulley bracket moves smoothly.

Torque: 34.5 N·m (350 kgf·cm, 25 ft·lbf)

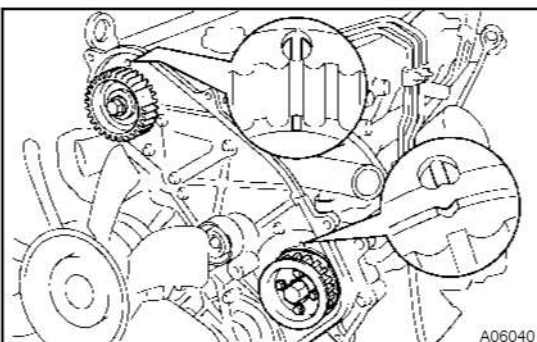

5. SET NO.1 CYLINDER TO BDC/COMPRESSION

- Check that the timing mark of the No.2 camshaft timing pulley is aligned with the BDC mark.

NOTICE:

Do not turn the crankshaft pulley. The valve heads will hit against the piston top.

- Align the timing mark of the No.1 camshaft timing pulley with the BDC mark.

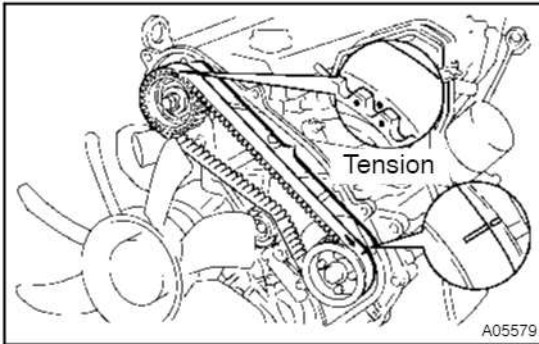

6. INSTALL TIMING BELT

NOTICE:

The engine should be cold.

HINT:

Align the points marked during removal, and install the belt with the arrow pointing in the direction of engine revolution.

- (a) Remove any oil or water on the pulleys, and keep them clean.

NOTICE:

Only wipe the pulleys; do not use any cleansing agent.

- (b) Install the timing belt under tension between the No.1 and No.2 camshaft timing pulleys.

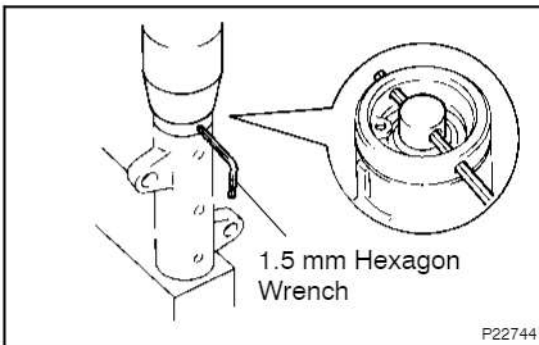

7. SET TIMING BELT TENSIONER

- (a) Using a press, slowly press in the push rod using 981 – 9,807 N (100 – 1,000 kgf, 220 – 2,205 lbf) of force.
- (b) Align the holes of the push rod and housing, pass a 1.5 mm hexagon wrench through the holes to keep the setting position of the push rod.
- (c) Release the press.

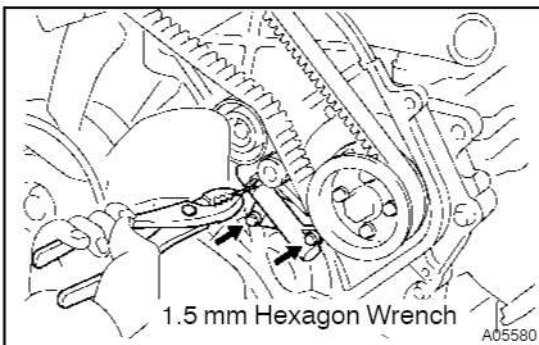

8. INSTALL TIMING BELT TENSIONER

- (a) Temporarily install the timing belt tensioner with the 2 bolts while pushing the idler pulley toward the timing belt.
- (b) Alternately tighten the 2 bolts.

Torque: 13 N·m (130 kgf·cm, 10 ft·lbf)

- (c) Remove the 1.5 mm hexagon wrench from the tensioner.

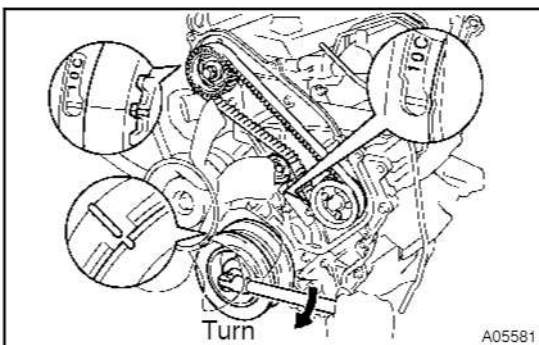

9. CHECK VALVE TIMING

Turn the crankshaft pulley clockwise and check that each pulley timing mark aligns with the TDC marks.

If the marks do not align, remove the timing belt and reinstall it.

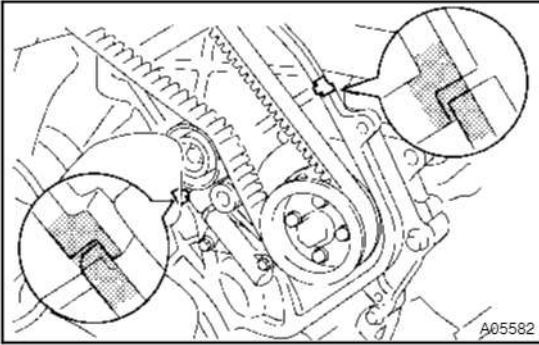
**10. INSTALL TIMING BELT COVER**

- (a) Remove any old packing (FIPG) material.
- (b) Apply seal packing to the camshaft oil seat retainer and timing gear cover as shown in the illustration.

Seal packing: Par No. 08826-00080 or equivalent

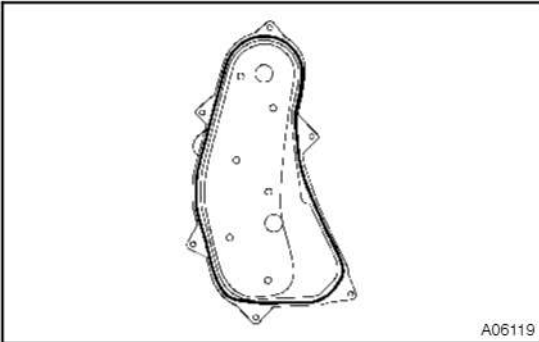

- (c) Check that timing belt cover gaskets have cracks or peeling, etc.

If the gasket has cracks or peeling, etc. replace it using these steps:

- Using a screwdriver and gasket scraper, remove all the oil gasket material.
- Thoroughly clean all components to remove all the loose material.
- Remove the backing paper from a new gasket and install the gasket evenly to the part of the timing belt cover shaded black in the illustration.

NOTICE:

Do not leave a gap between them.

Cut off any excess gasket.

- After installing the gasket, press down on it so that the adhesive firmly sticks to the timing belt cover.

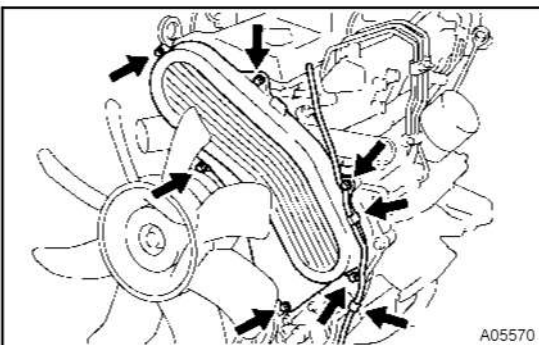

- (d) Install the timing belt cover with the 6 seal washers and 6 bolts.
- (e) Install the vacuum hose to the the timing belt cover and vacuum hose to the clip.

11. INSTALL INTAKE PIPE ASSEMBLY

(See page EM-36)

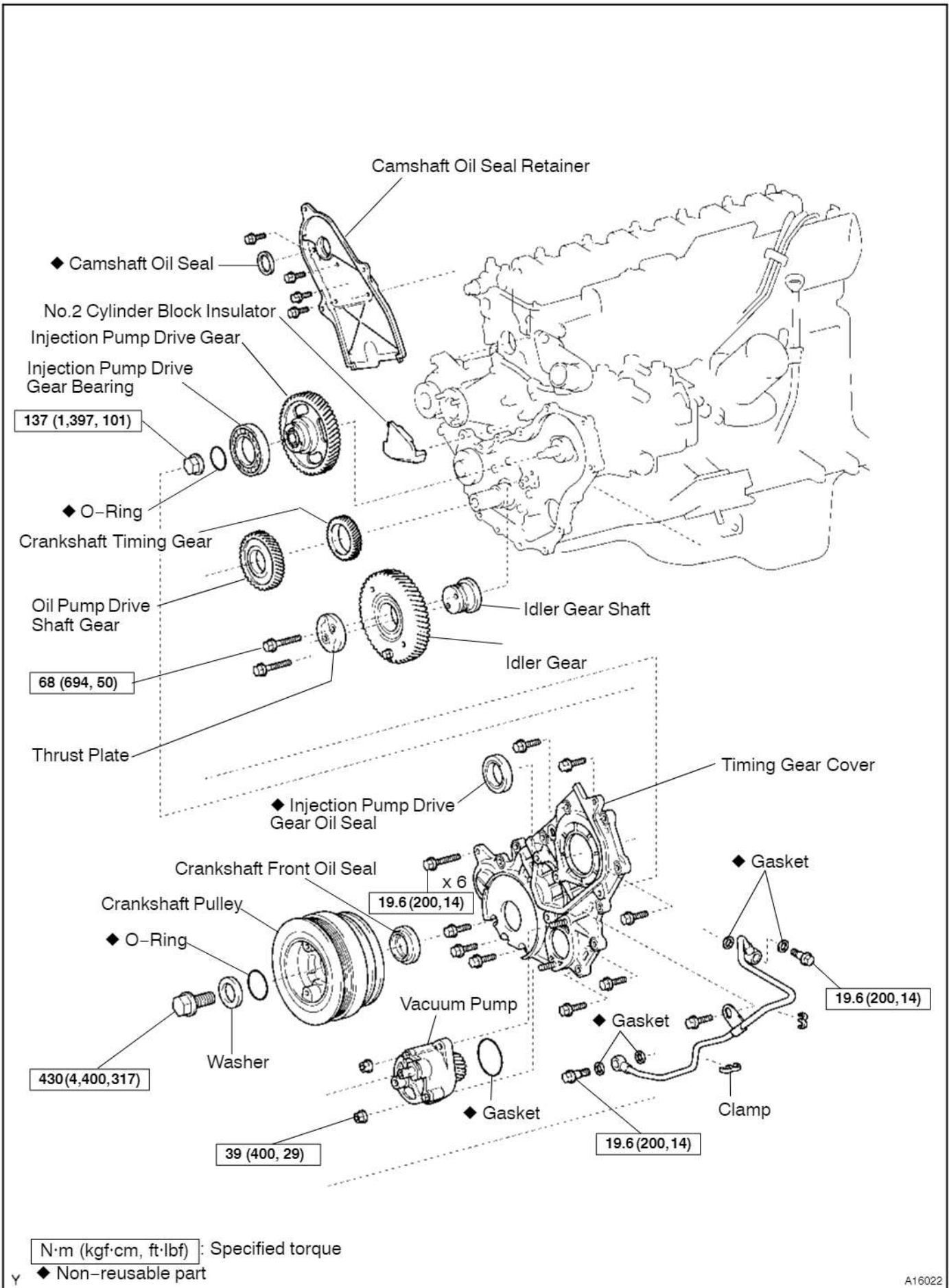

cardiagn.com

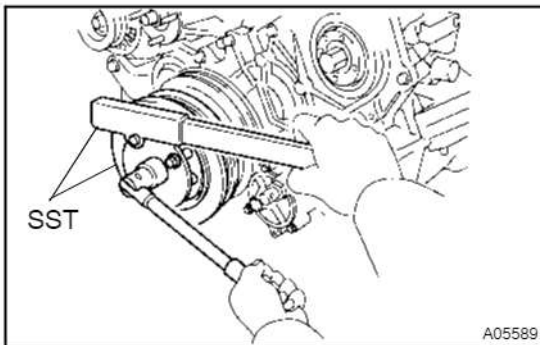

REMOVAL

1. REMOVE DRIVE BELTS, FLUID COUPLING AND WATER PUMP PULLEY

2. LOOSEN CRANKSHAFT PULLEY

Using SST, loosen the pulley bolt.

SST 09213-58013 (90201-08131, 91111-50845),
09330-00021

NOTICE:

If the timing belt is disengaged, having the crankshaft pulley at the wrong angle can cause the piston head and valve head to come into contact with each other when you remove the camshaft timing pulley causing damage.

3. REMOVE TIMING BELT AND TIMING PULLEYS

(See page EM-3)

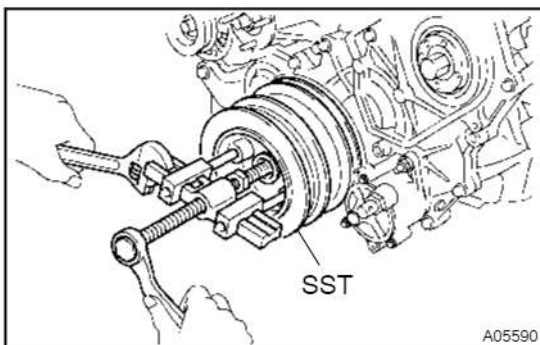

4. REMOVE CRANKSHAFT PULLEY

- (a) Remove the pulley bolt and plate washer.

NOTICE:

Do not turn the crankshaft pulley. The valve heads will hit against the piston top.

- (b) Using SST, remove the crankshaft pulley. The valve heads will hit against the piston top.

SST 09950-50013 (09951-05010, 09952-05010,
09953-05010, 09953-05020, 09954-05021)

- (c) Remove the O-ring from the crankshaft pulley.

5. REMOVE OIL PIPE

- (a) Remove the 2 union bolts and 4 gaskets.

- (b) Remove the bolt and oil pipe.

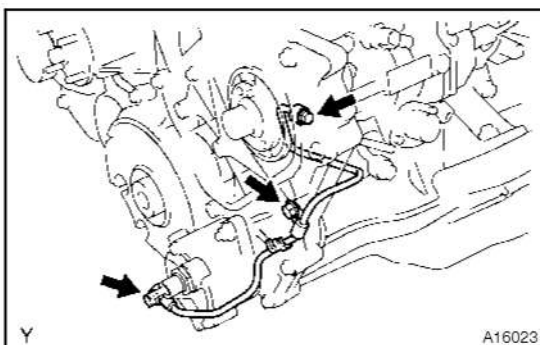

6. REMOVE VACUUM PUMP

- (a) Remove the 2 nuts and vacuum pump.

- (b) Remove the O-ring.

7. REMOVE CAMSHAFT OIL SEAL RETAINER

(See Pub. No. RM617E, on page EM-91)

8. REMOVE NO.2 CYLINDER BLOCK INSULATOR

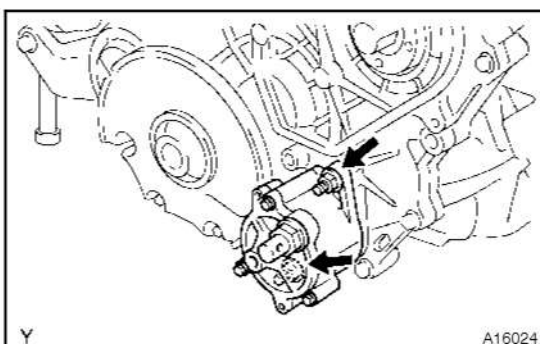

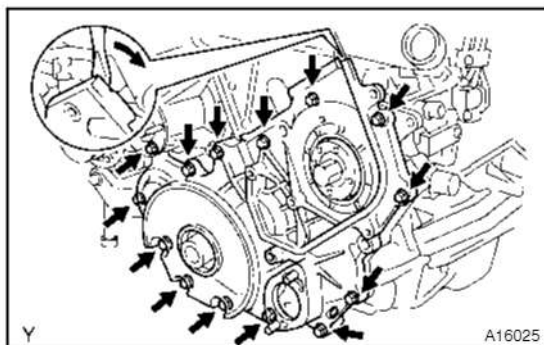
**9. REMOVE TIMING GEAR COVER**

- (a) Remove the 14 bolts.
- (b) Pry out the timing gear cover.

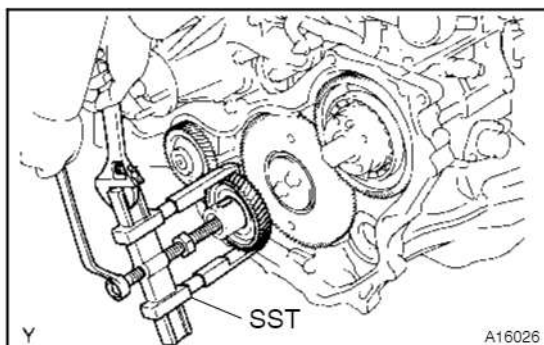
**10. REMOVE OIL PUMP DRIVE SHAFT GEAR**

Using SST, remove the drive shaft gear.

SST 09950-40011 (09951-04010, 09952-04010, 09953-04010, 09953-04020, 09954-04010, 09955-04061)

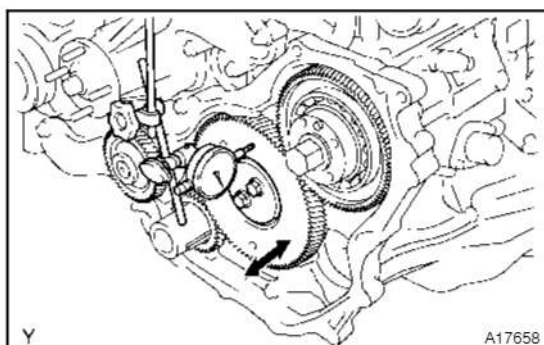
**11. CHECK THRUST CLEARANCE OF IDLER GEAR**

Using a dial indicator, measure the thrust clearance.

Standard thrust clearance:

0.07 - 0.12 mm (0.0028 - 0.0047 in.)

Maximum thrust clearance:

0.12 mm (0.0047 in.)

If the thrust clearance is greater than maximum, replace the thrust plate. If necessary, replace the idler gear and/or idler gear shaft.

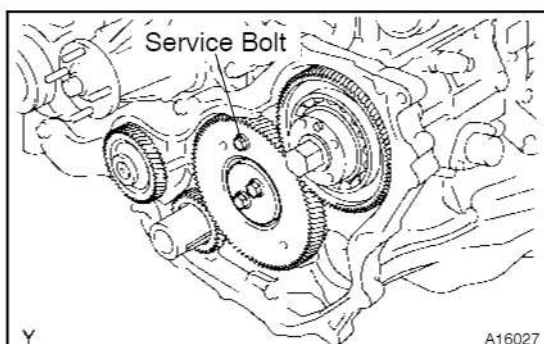
**12. REMOVE IDLER GEAR**

- (a) Secure the idler sub-gears to the idler gear with a service bolt.

Recommended service bolt:

Thread diameter	8 mm
Thread pitch	1.25 mm
Bolt length	25.0 mm (0.98 in.)

- (b) Remove the 2 bolts and thrust plate.

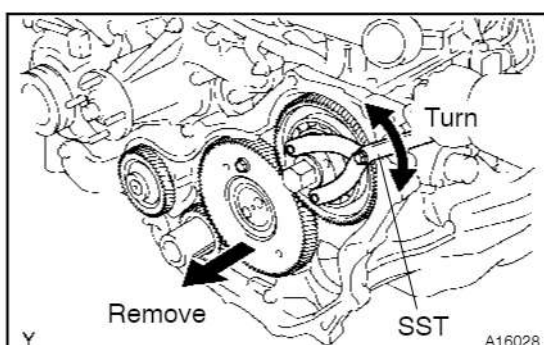

- (c) Using SST, turn the injection pump drive gear clockwise or counterclockwise and remove the idler gear.
SST 09960-10010 (09962-01000, 09963-00600)
- (d) Remove the idler gear shaft.

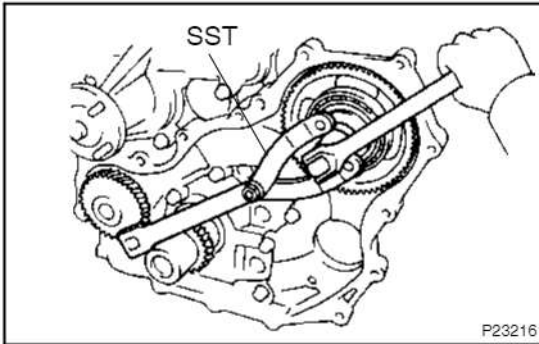
**13. REMOVE INJECTION PUMP DRIVE GEAR**

- (a) Using SST, loosen the gear nut.
SST 09960-10010 (09962-01000, 09963-00600)
- (b) Remove the gear nut and O-ring.

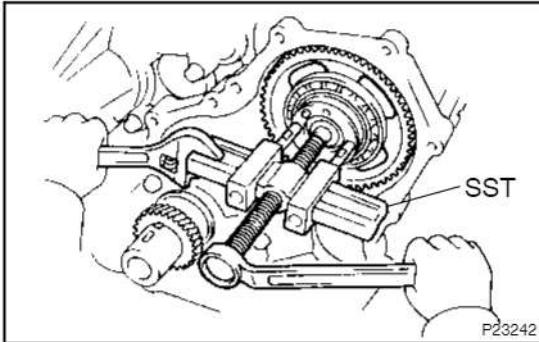

- (c) Using SST, remove the drive gear.
SST 09950-50013 (09951-05010, 09952-05010, 09953-05010, 09954-05021)

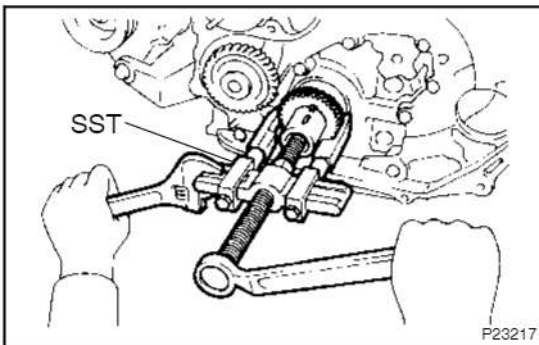
**14. REMOVE CRANKSHAFT TIMING GEAR**

Using SST, remove the timing gear.

- SST 09950-40011 (09951-04010, 09952-04010, 09953-04020, 09954-04010, 09955-04061)

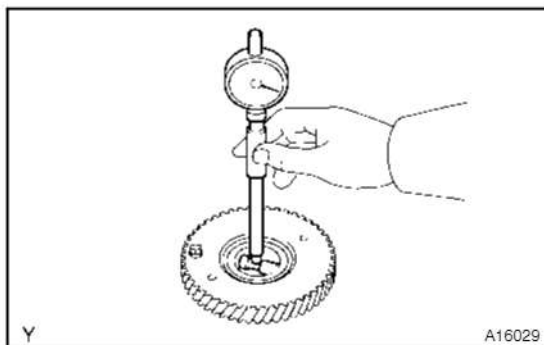

INSPECTION

1. INSPECT IDLER GEAR

- (a) Using a cylinder gauge, measure the inside diameter of the idler gear.

Idler gear inside diameter:

45.045 – 45.065 mm (1.7734 – 1.7742 in.)

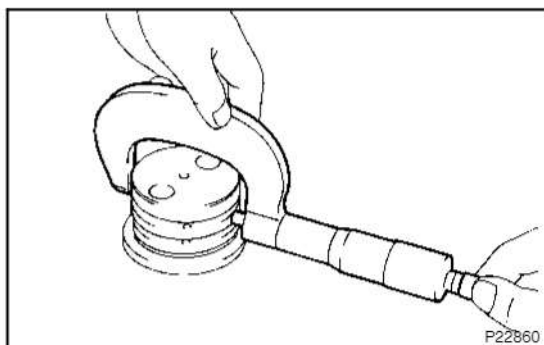

- (b) Using a micrometer, measure the diameter of the idler gear shaft.

Idler gear shaft diameter:

44.950 – 44.975 mm (1.7697 – 1.7707 in.)

- (c) Subtract the idler gear shaft diameter measurement from the idler gear inside diameter measurement.

Standard oil clearance:

0.070 – 0.115 mm (0.0028 – 0.0045 in.)

Maximum oil clearance: 0.115 mm (0.0045 in.)

If the clearance is greater than maximum, replace the gear and shaft.

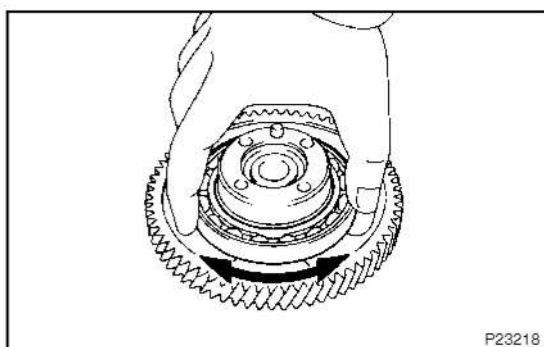

2. INSPECT INJECTION PUMP DRIVE GEAR BEARING

Check that bearing is not rough or worn.

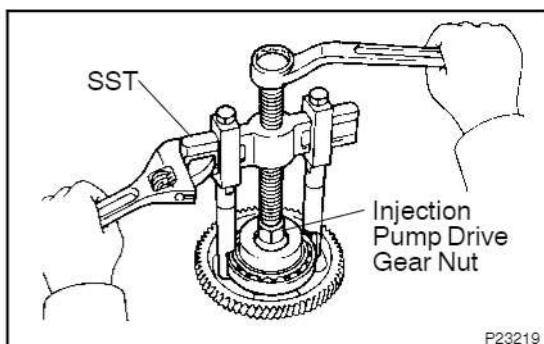

3. IF NECESSARY, REPLACE INJECTION PUMP DRIVE GEAR BEARING

- (a) Remove bearing

Using SST, remove the bearing

SST 09950-40011 (09951-04010, 09952-04010, 09953-04020, 09954-04010, 09955-04041)

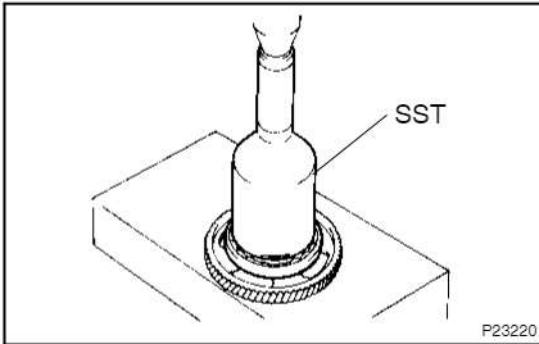

- (b) Install bearing
Using SST and a press, press in a new bearing.
SST 09502-12010, 09223-15020,
09950-70010 (09951-07100)

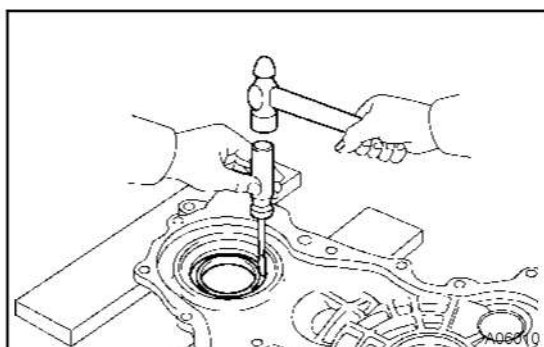
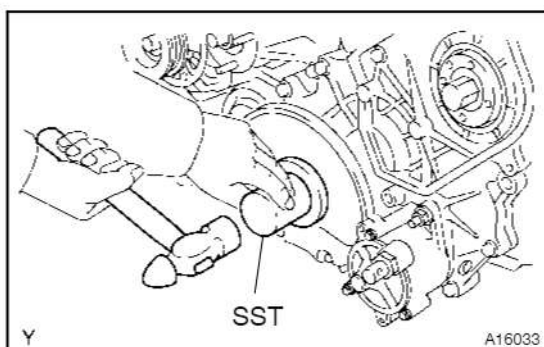
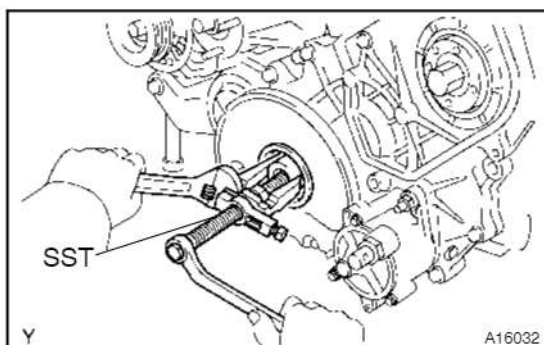
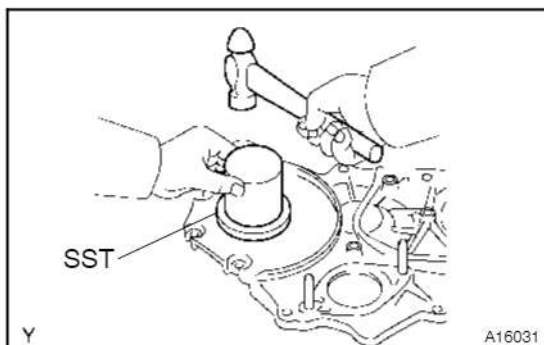
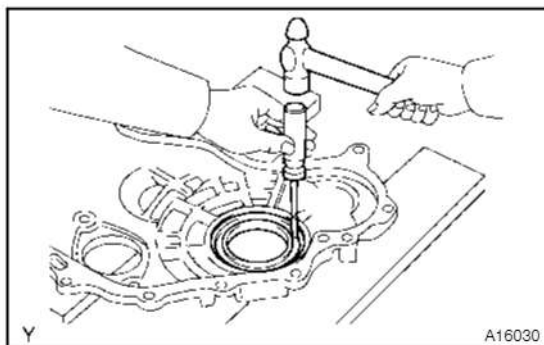

REPLACEMENT

HINT:

There are 2 methods (a and b) to replace the oil seal as follows:

1. REPLACE CRANKSHAFT FRONT OIL SEAL

- (a) If timing gear cover is removed from cylinder block:
- (1) Using a screwdriver and hammer, tap out the oil seal.
 - (2) Using SST and a hammer, tap in a new oil seal until its surface is flush with the timing gear cover edge.
SST 09223-78010
 - (3) Apply MP grease to the oil seal lip.

- (b) If timing gear cover is installed to the cylinder block:
- (1) Using SST, remove the oil seal.
SST 09308-10010, 09950-50013 (09953-05010)

- (2) Apply MP grease to a new oil seal lip.
- (3) Using SST and a hammer, tap in the oil seal until its surface is flush with the timing gear cover edge.
SST 09223-78010

HINT:

There are 2 methods (a and b) to replace the oil seal as follows:

2. REPLACE INJECTION PUMP DRIVE GEAR OIL SEAL

- (a) If timing gear cover is removed from cylinder block:
- (1) Using a screwdriver and hammer, tap out the oil seal.

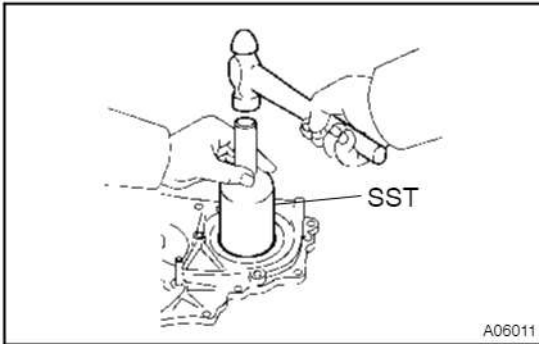

- (2) Using SST and a hammer, tap in a new oil seal until its surface is flush with the timing gear cover edge.

SST 09214-76011

- (3) Apply MP grease to the oil seal lip.

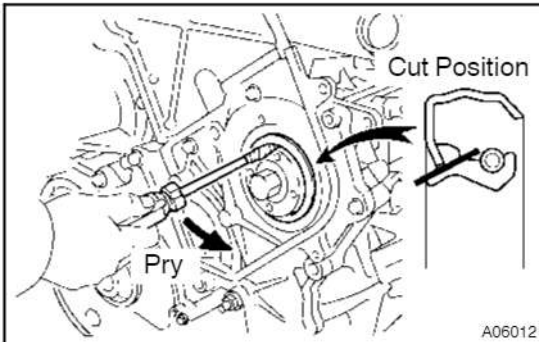

- (b) If timing gear cover is installed to the cylinder block:

- (1) Using a knife, cut off the oil seal lip.

- (2) Using a screwdriver, pry out the oil seal.

NOTICE:

Be careful not to damage the injection pump drive gear. Tape the screwdriver tip.

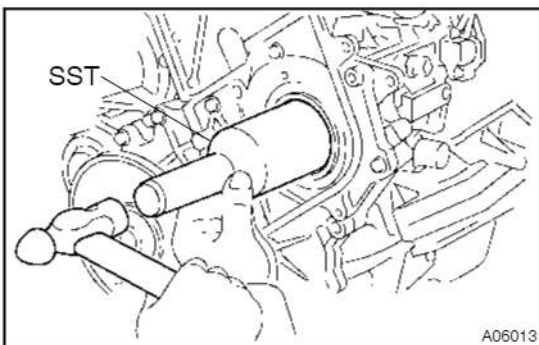

- (3) Apply MP grease to the oil seal lip.

- (4) Using SST and a hammer, tap in a new oil seal until its surface is flush with the timing gear cover edge.

SST 09214-76011

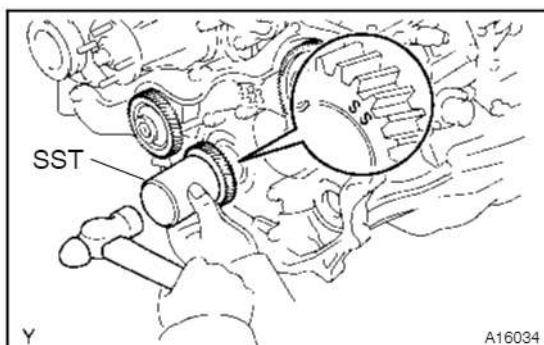

INSTALLATION

1. INSTALL CRANKSHAFT TIMING GEAR

- Put the timing gear with the timing mark facing forward.
- Align the set key on the crankshaft with the key groove of the timing gear.
- Using SST and a hammer, tap in the timing gear.
SST 09223-00010

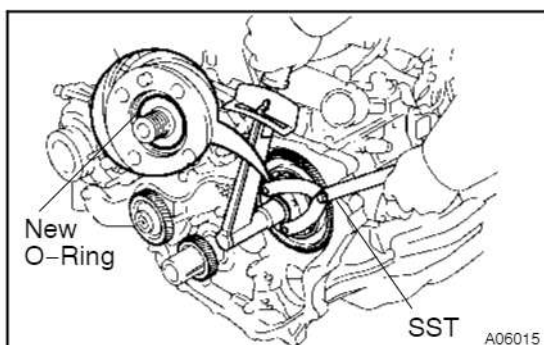

2. INSTALL INJECTION PUMP DRIVE GEAR

- Align the set key on the drive shaft with the key groove of the drive gear, and install the drive gear.
- Install a new O-ring to the drive gear groove.
- Install the gear net.
- Using SST, tighten the gear nut.
SST 09960-10010 (09962-01000, 09963-00600)
Torque: 137 N·m (1,397 kgf·cm, 101 ft·lbf)

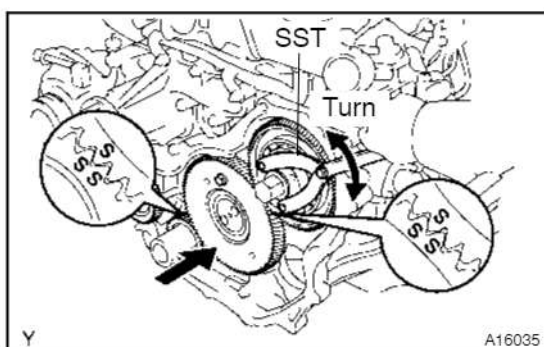

3. INSTALL IDLER GEAR

- Align the bolt holes of the idler gear shaft and cylinder block, and install the idler gear shaft.
- Using SST, turn the injection pump drive gear clockwise or counterclockwise, and align timing marks "S" and "SS" of the idler gear with timing mark "SS" of the crankshaft timing gear and timing mark "S" of the injection pump drive gear respectively, and mesh the gears.
SST 09960-10010 (09962-01000, 09963-00600)

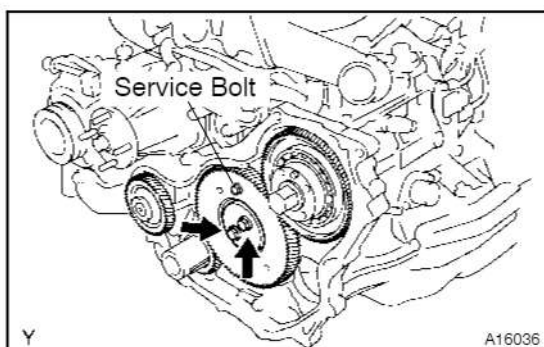

- Install the thrust plate with the 2 bolts.
Torque: 68 N·m (694 kgf·cm, 50 ft·lbf)
- Remove the service bolt.

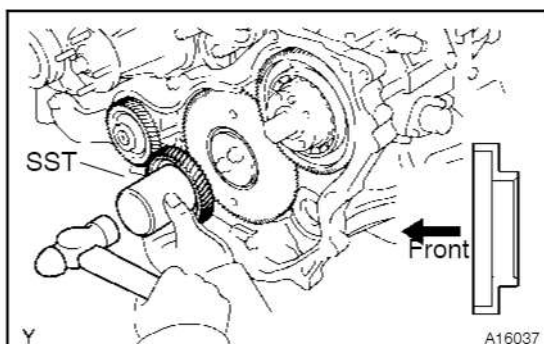

4. INSTALL OIL PUMP DRIVE SHAFT GEAR

- Align the set key on the crankshaft with the key groove of the drive shaft gear.
- Using SST and a hammer, tap in the drive shaft gear.
SST 09223-00010

5. INSTALL NO. 2 CYLINDER BLOCK INSULATOR

6. INSTALL TIMING GEAR COVER

- Remove and old packing (FIPG) material and be careful not to drop any oil on the contact surface of the timing gear cover and cylinder block.

- Using a razor blade and gasket scraper, remove all the old packing (FIPG) material from the gasket surfaces and sealing groove.
- Thoroughly clean all components to remove all the loose material.
- Using a non-residue solvent, clean both sealing surfaces.

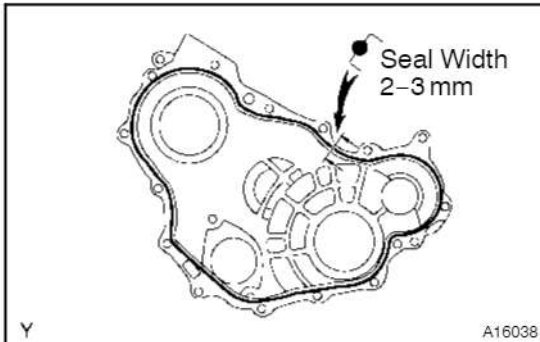

- (b) Apply seal packing to the timing gear cover as shown in the illustration.

Part No. 08826-00080 or equivalent

- Install a nozzle that has been cut to a 2 – 3 mm (0.08 – 0.12 in.) opening.
- Parts must be assembled within 5 minutes of application. Otherwise the material must be reapplied. Otherwise the material must be removed and reapplied.
- Immediately remove nozzle from the tube and reinstall cap.

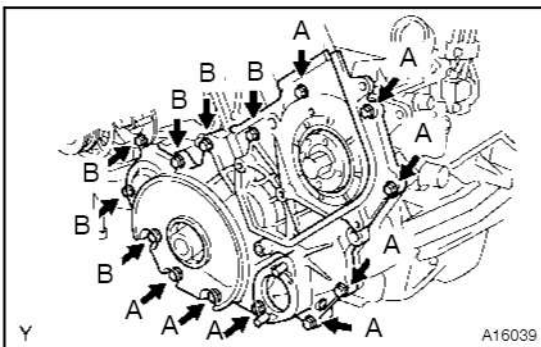

7. INSTALL CRANKSHAFT PULLEY

- (a) Install the timing gear cover, clamp and bracket with the 14 bolts.

Torque: 19.6 N·m (200 kgf·cm, 14 ft·lbf)

HINT:

Each bolt length is indicated in the illustration.

Bolt length:

A 25 mm (0.98 in.)

B 50 mm (1.97 in.)

- (b) Install a new O-ring to the crankshaft pulley groove.
- (c) Align the set key on the crankshaft with the key groove of the crankshaft pulley.

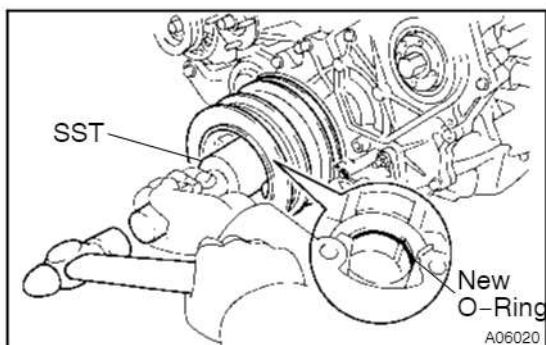

- (d) Using SST and a hammer, tap in the crankshaft pulley.
SST 09214-60010
- (e) Temporarily install the plate washer and pulley nut.

NOTICE:

Do not turn the crankshaft pulley. The valve heads will hit against the piston top.

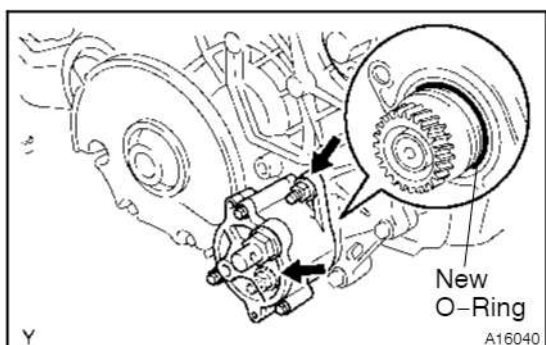
**8. INSTALL VACUUM PUMP**

- (a) Install a new O-ring to the vacuum pump.
(b) Install the vacuum pump with the 2 nuts.

Torque: 39 N·m (400 kgf·cm, 29 ft·lbf)

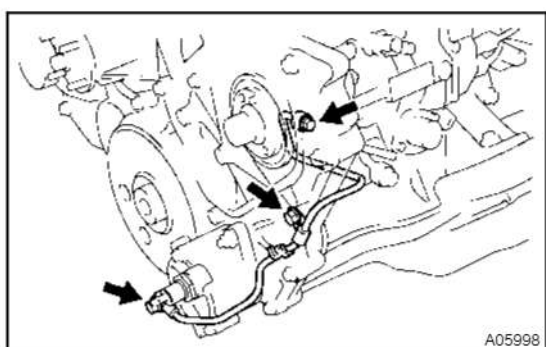
**9. INSTALL OIL PIPE**

Install the oil pipe with the bolt, 2 union bolts and 4 new gaskets.

Torque:

Bolt 19.6 N·m (200 kgf·cm, 14 ft·lbf)

Union bolt 18 N·m (185 kgf·cm, 13 ft·lbf)

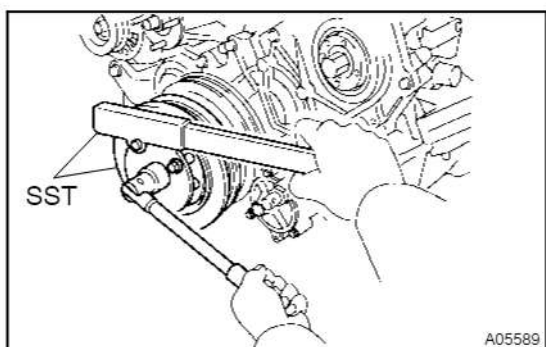
10. INSTALL CAMSHAFT OIL SEAL RETAINER
(See Pub. No. RM617E, on page EM-91)**11. INSTALL TIMING PULLEYS AND TIMING BELT**
(See page EM-5)**12. TIGHTEN CRANKSHAFT PULLEY BOLT**

Using SST, tighten the pulley bolt.

SST 09213-58013 (90201-08131, 91111-50845),
09330-00021

Torque: 430 N·m (4,400 kgf·cm, 317 ft·lbf)

**13. INSTALL WATER PUMP PULLEY, FAN, FLUID COU-
PLING AND DRIVE BELTS**

(See Pub. No. RM617E, on page CO-9)

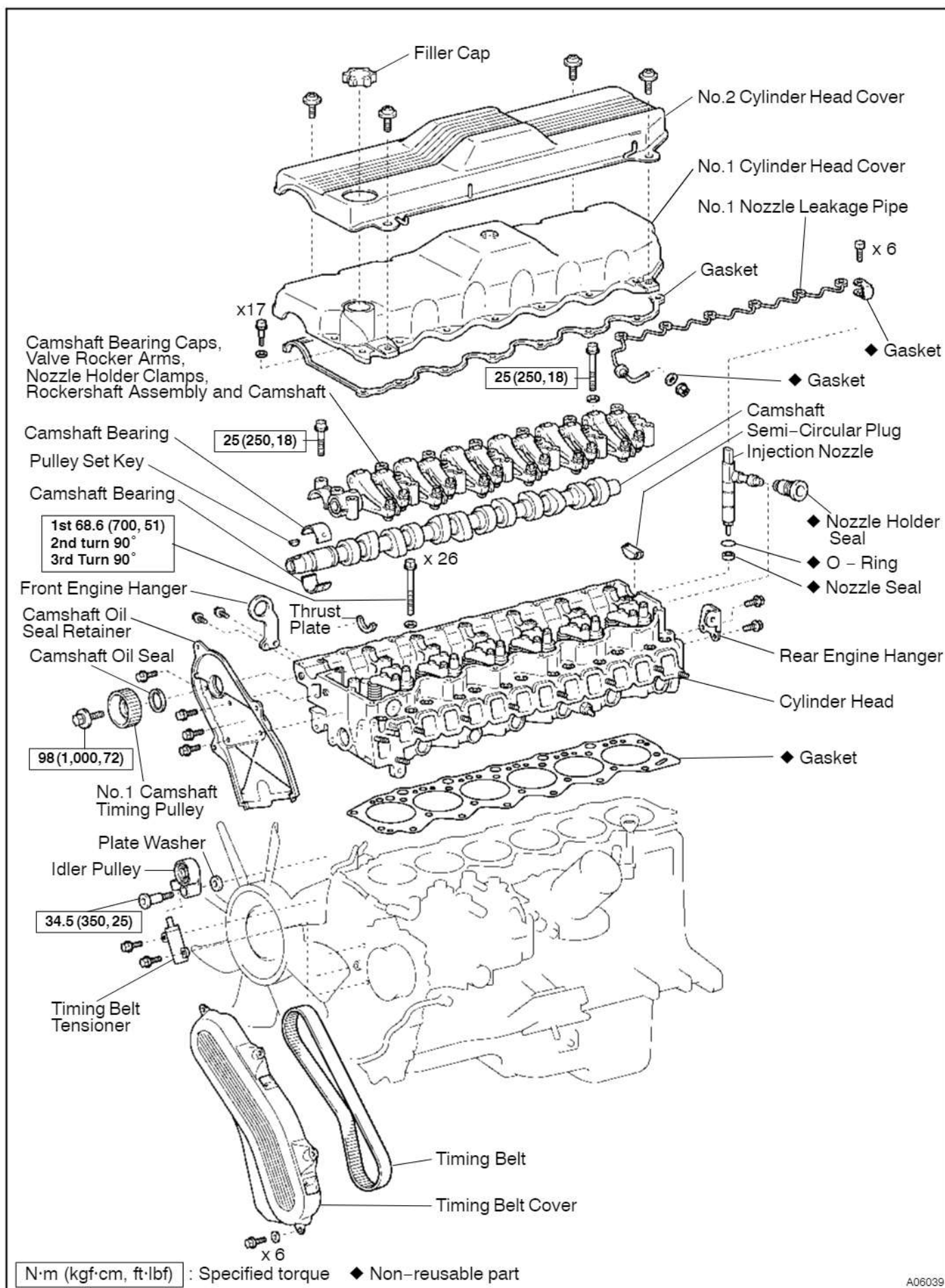

cardiagn.com

Camshaft Bearing Cap, Valve Rocker Arm, Nozzle Holder Clamp and Rocker Shaft Assembly

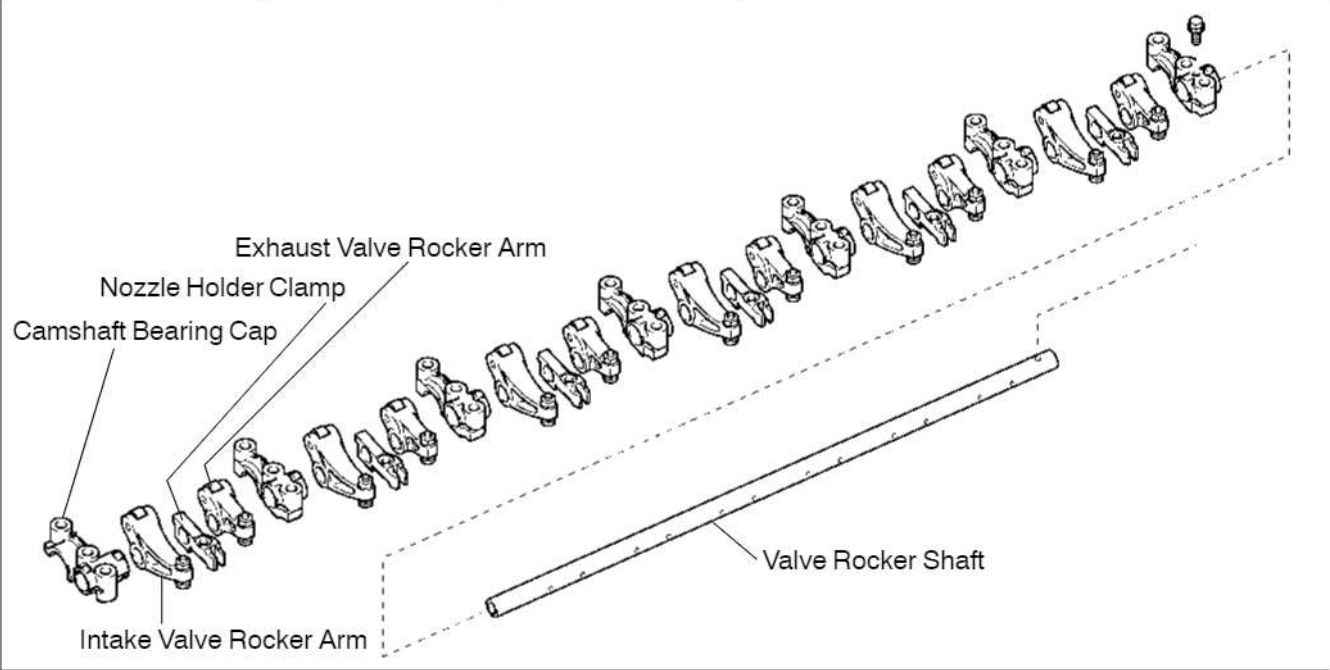

Cylinder Head Assembly

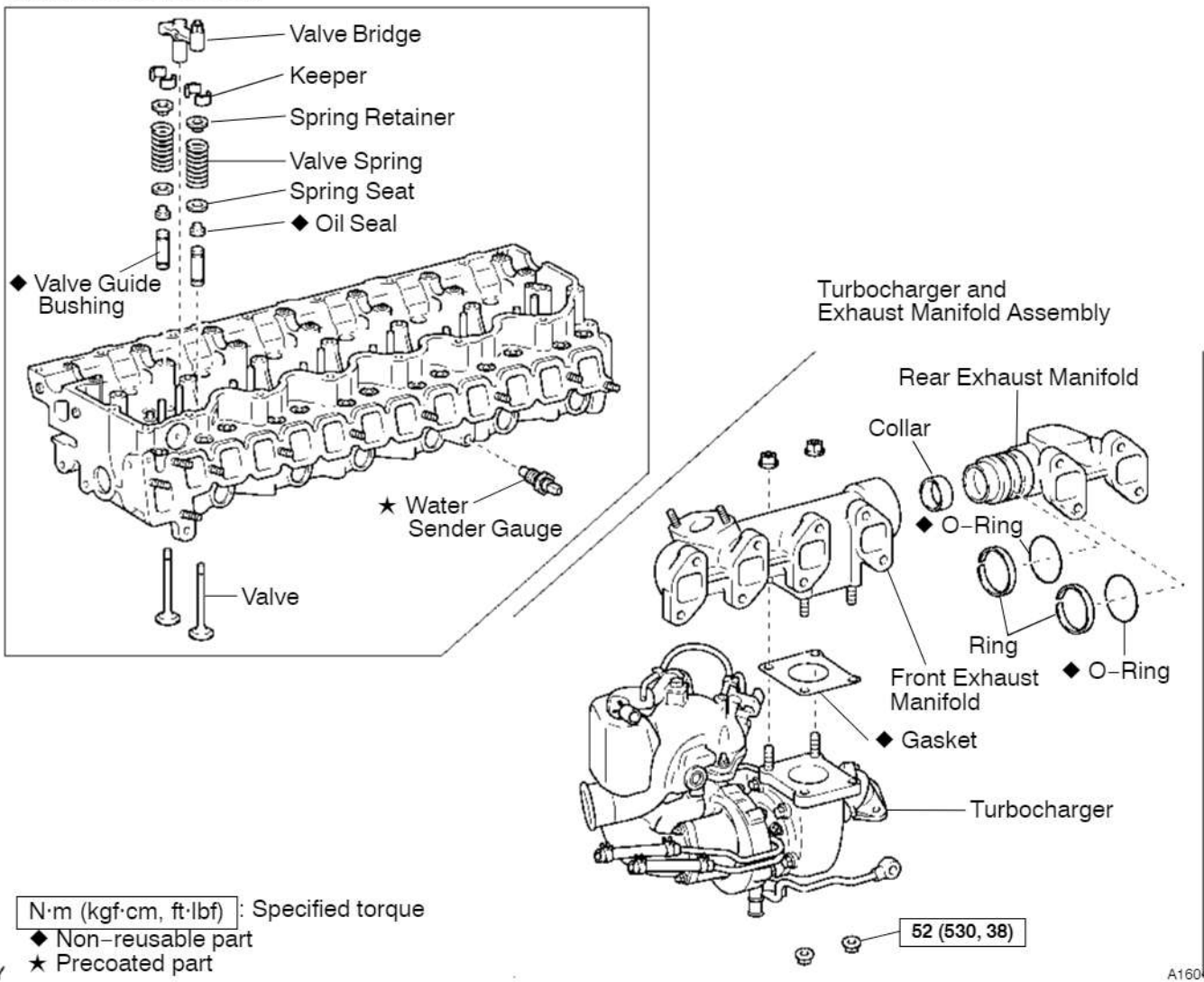

cardiagn.com

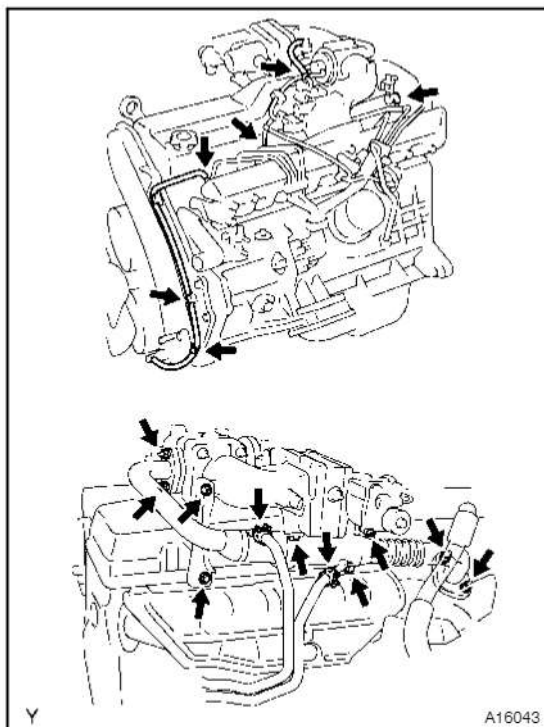

REMOVAL

1. REMOVE INTAKE PIPE ASSEMBLY

- (a) Disconnect the vacuum hose to the clamp and timing belt cover.
- (b) Disconnect the 5 vacuum hoses to the No.2 cylinder head cover.
- (c) Remove the 2 nuts and gasket from the EGR cooler pipe.
- (d) Remove the 4 bolts and 2 intake pipe assembly brackets.
- (e) Remove the 2 bolts, 2 nuts, gasket and intake pipe assembly.

2. REMOVE EGR COOLER PIPE

- (a) Disconnect the 2 water hoses from the EGR cooler pipe.
- (b) Remove the bolt, 2 nuts, gasket and EGR cooler pipe from the intake pipe assembly.

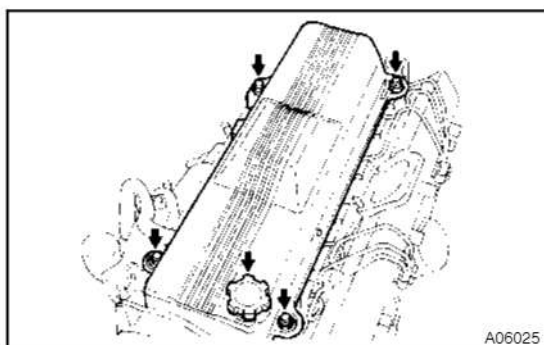

3. REMOVE NO.2 CYLINDER HEAD COVER

- (a) Remove the oil filler cap.
- (b) Remove the 4 bolts and cylinder head No.2 cover.

4. REMOVE INJECTION PIPE

(See Pub. No. RM617E, on page FU-33)

5. REMOVE 2 INTAKE MANIFOLD INSULATOR

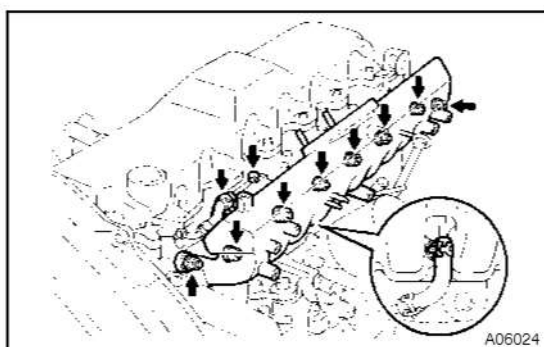

6. REMOVE INTAKE MANIFOLD WITH INTAKE AIR CONTROL VALVE

- (a) Remove the fuel hose from the injection pump.
- (b) Remove the 8 nuts, 8 seal washers, 4 gaskets and intake manifold insulator with the intake air control valve.

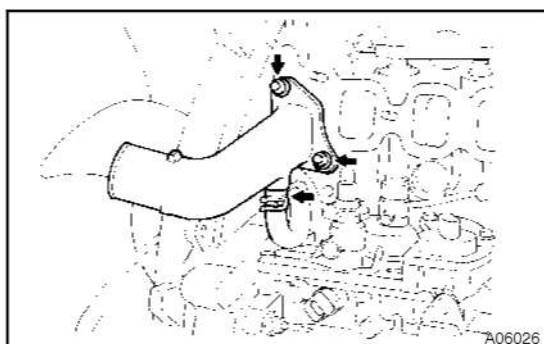

7. REMOVE WATER OUTLET

- (a) Disconnect the water bypass hose from the water outlet.
- (b) Remove the 2 bolts, water outlet and gasket.

8. REMOVE TURBOCHARGER AND EXHAUST MANIFOLD ASSEMBLY

(See page TC-7)

9. REMOVE EXHAUST MANIFOLD FROM TURBOCHARGER

(See page TC-7)

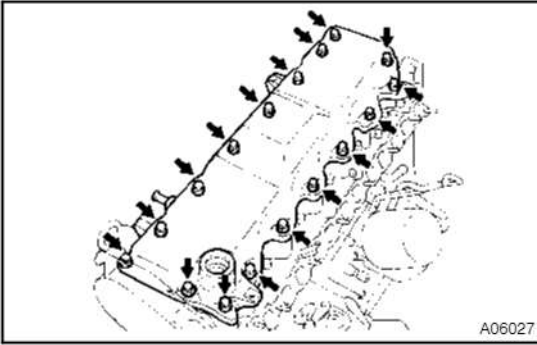
**10. REMOVE NO.1 CYLINDER HEAD COVER**

Remove the 17 bolts, 17 seal washers, No.1 cylinder head cover and gasket.

11. REMOVE TIMING BELT AND PULLEY

(See page EM-3)

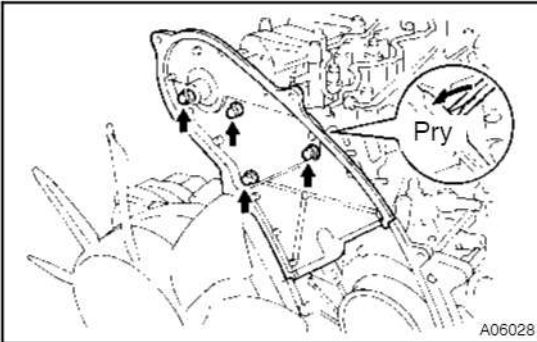
**12. REMOVE CAMSHAFT OIL SEAL RETAINER**

- (a) Remove the 4 bolts.
- (b) Pry out the oil seal retainer.

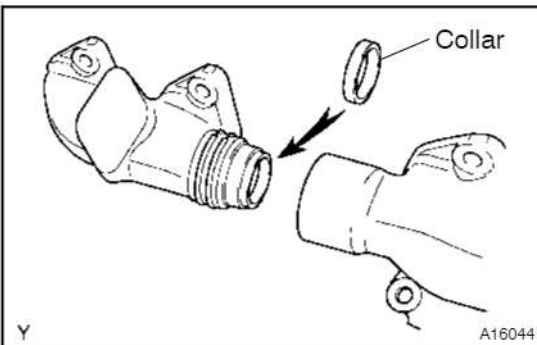
13. REMOVE 2 ENGINE HANGER**14. SEPARATE EXHAUST MANIFOLDS**

- (a) Separate the front and rear exhaust manifolds.
- (b) Remove the collar.

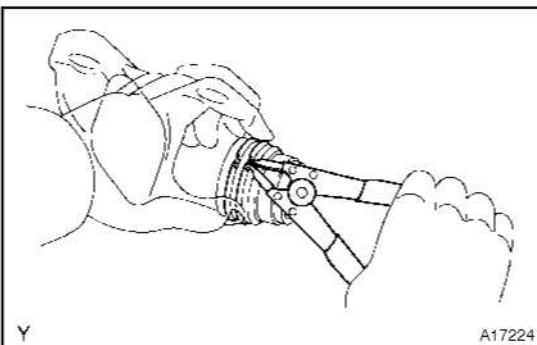

- (c) Using snap ring pliers, remove the 2 rings from the rear exhaust manifold.
- (d) Remove all the O-ring materials from the rear exhaust manifold grooves.

15. REMOVE SEMI-CIRCULAR PLUG**16. REMOVE INJECTION NOZZLES**

(See Pub. No. RM617E, on page FU-33)

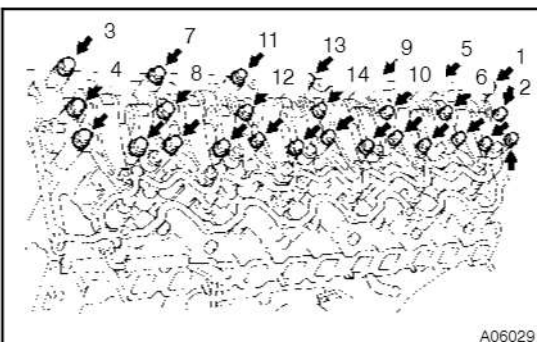
**17. REMOVE CAMSHAFT BEARING CAPS, VALVE ROCKER ARMS, NOZZLE HOLDER CLAMPS, ROCKER SHAFT ASSEMBLY AND CAMSHAFT**

- (a) Remove the 13 bolts.
- (b) Uniformly loosen and remove the 14 other bolts in several passes, in the sequence shown.
- (c) Remove the 7 bearing caps, 12 rocker arms, 6 holder clamps, rocker shaft assembly and 7 upper camshaft bearings.

- Keep the bearing caps, rocker arms and nozzle holder clamps installed with the rocker shaft.
 - Keep the bearings inserted with the bearing cap.
- (d) Remove the camshaft, thrust plate and 7 lower camshaft bearings.

HINT:

Arrange the bearings in correct order.

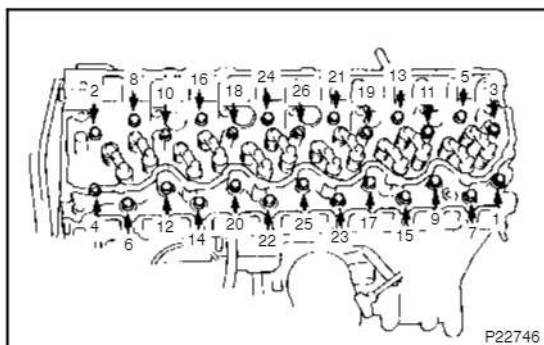

18. REMOVE CYLINDER HEAD ASSEMBLY

- (a) Disconnect the water bypass hose (from the injection pump) from the cylinder head.
- (b) Uniformly loosen and remove the 26 cylinder head bolts in several passes, in the sequence shown.

NOTICE:

Head warpage or cracking could result from removing bolts in incorrect order.

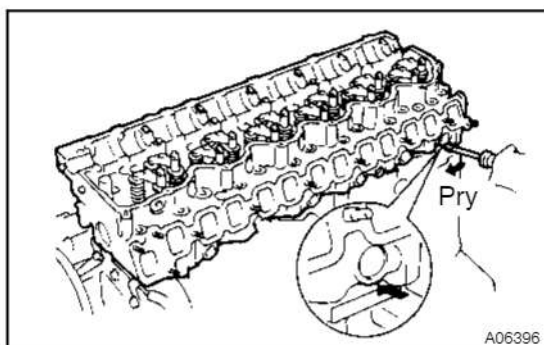

- (c) Lift the cylinder head from the dowels on the cylinder block, and place the cylinder head on wooden blocks on a bench.

HINT:

If the cylinder head is difficult to lift off, pry with a screwdriver between the cylinder head and block.

NOTICE:

Be careful not to damage the contact surfaces of the cylinder head and cylinder block.

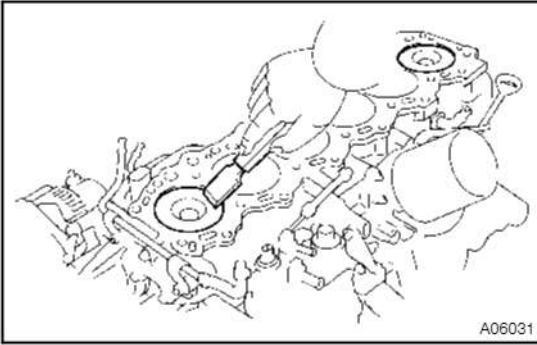

A06031

INSPECTION

1. CLEAN TOP SURFACES OF PISTONS AND CYLINDER BLOCK

- (a) Turn the crankshaft, and bring each piston to the top dead center (TDC). Using a gasket scraper, remove all the carbon from the piston top surface.

- (b) Remove all the gasket material from the top of the cylinder block.

NOTICE:

Be careful not to scratch the surfaces.

- (c) Using compressed air, blow carbon and oil from the bolt holes.

CAUTION:

Protect your eyes when using high-compressed air.

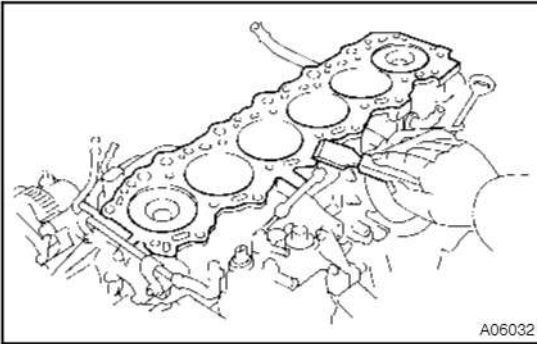

A06032

2. CLEAN CYLINDER HEAD

- (a) Remove gasket material
Using a gasket scraper, remove all the gasket material from the cylinder block contact surface.

NOTICE:

Be careful not to scratch the cylinder block contact surface.

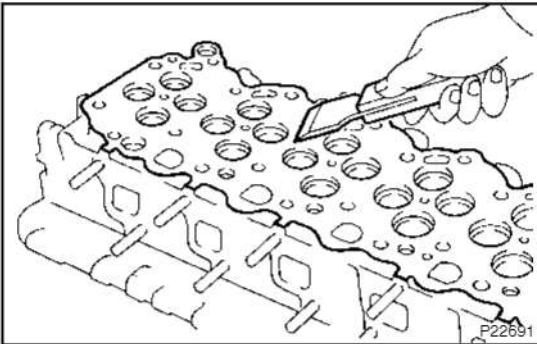

P22691

- (b) Clean intake and exhaust ports
Using a wire brush, remove all the carbon from the intake and exhaust ports.

NOTICE:

Be careful not to scratch the valve contact surface.

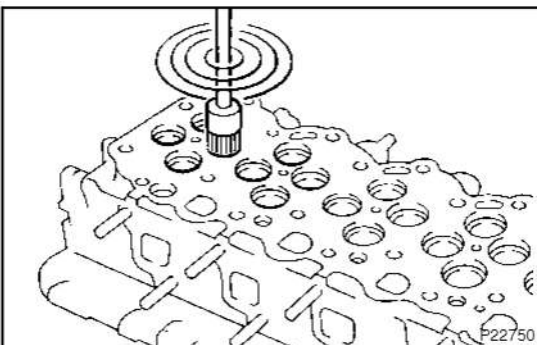

P22750

- (c) Clean valve guide bushings
Using a valve guide bushing brush and solvent, clean all the guide bushings.

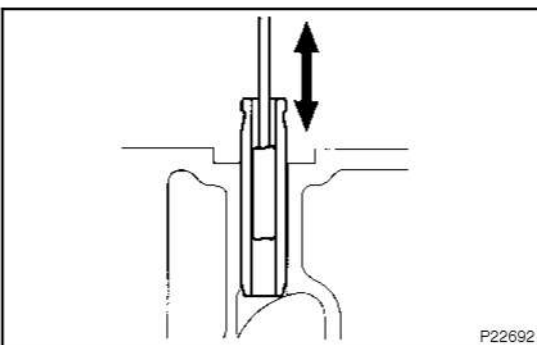

P22692

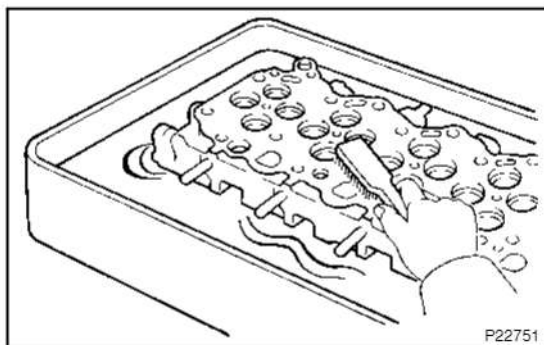

- (d) Clean cylinder head
Using a soft brush and solvent, thoroughly clean the cylinder head.

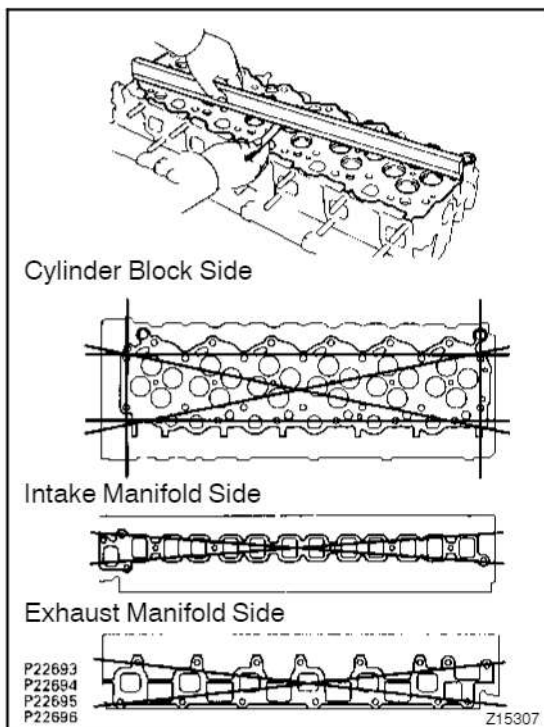

3. INSPECT CYLINDER HEAD

- (a) Inspect for flatness
Using a precision straight edge and thickness gauge, measure the surfaces contacting the cylinder block and the manifolds for warpage.

Maximum warpage: 0.20 mm (0.0079 in.)

If warpage is greater than maximum, replace the cylinder head.

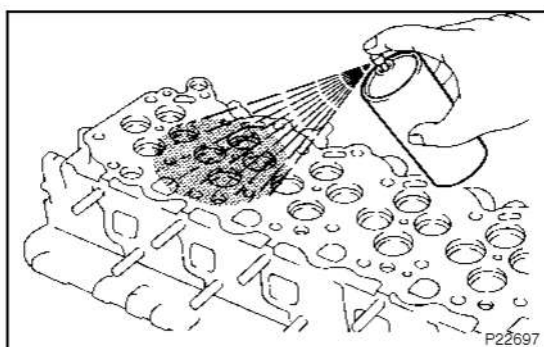

- (b) Inspect for cracks
Using a dye penetrant, check the intake ports, exhaust ports and surface contacting the cylinder block.
If cracked, replace the cylinder head.

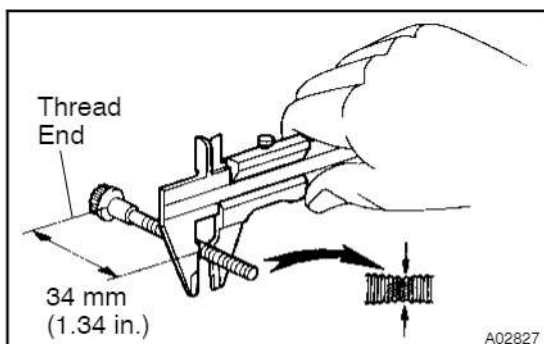

- (c) Inspect cylinder head bolts
Using vernier calipers, measure the minimum outer diameter of the compressed thread at the measuring point.

Standard outer diameter:

10.800 – 11.000 mm (0.4252 – 0.4331 in.)

Minimum outer diameter: 10.55 mm (0.4154 in.)

If the outer diameter is less than minimum, replace the bolt.

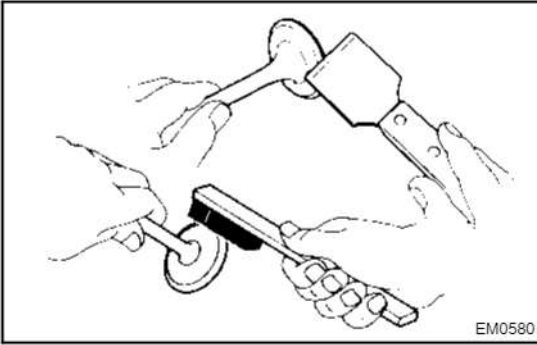

4. CLEAN VALVES

- (a) Using a gasket scraper, chip off any carbon from the valve head.
- (b) Using a wire brush, thoroughly clean the valve.

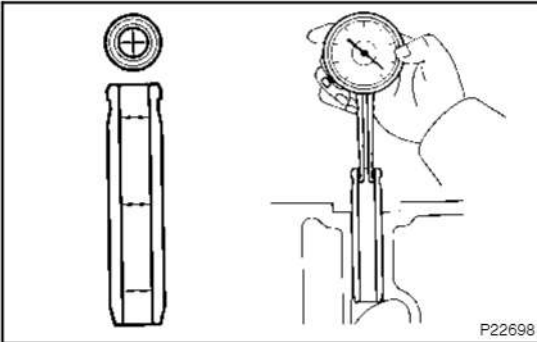

5. INSPECT VALVE STEMS AND GUIDE BUSHINGS

- (a) Using a caliper gauge, measure the inside diameter of the guide bushing.

Busing inside diameter:

7.010 – 7.030 mm (0.2760 – 0.2768 in.)

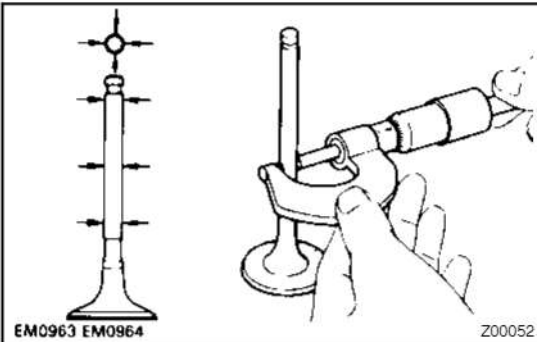

- (b) Using a micrometer, measure the diameter of the valve stem.

Valve stem diameter:

Intake

6.970 – 6.985 mm (0.2744 – 0.2750 in.)

Exhaust

6.960 – 6.975 mm (0.2740 – 0.2746 in.)

- (c) Subtract the valve stem diameter measurement from the guide bushing inside diameter measurement.

Standard oil clearance:

Intake

0.025 – 0.060 mm (0.0010 – 0.0024 in.)

Exhaust

0.035 – 0.070 mm (0.0014 – 0.0028 in.)

Maximum oil clearance:

Intake

0.08 mm (0.0031 in.)

Exhaust

0.10 mm (0.0039 in.)

If the clearance is greater than maximum, replace the valve and cylinder head.

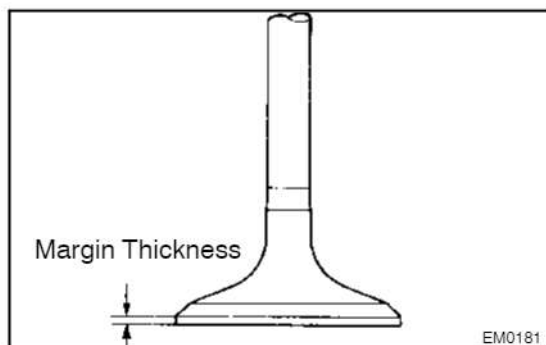

6. INSPECT VALVES

- (a) Check the valve face for wear.
If the valve face is worn, replace the valve.
- (b) Check the valve head margin thickness.

Standard margin thickness: 1.00 mm (0.0394 in.)

Minimum margin thickness: 0.83 mm (0.0327 in.)

If the margin thickness is less than minimum, replace the valve

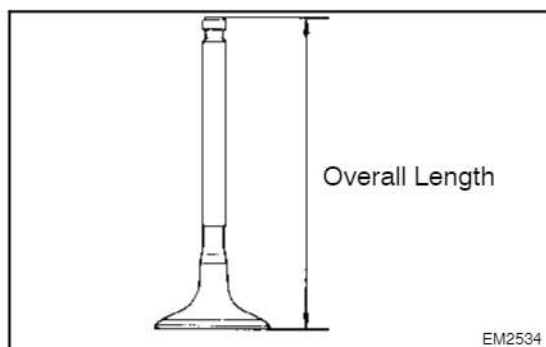

- (c) Check the valve overall length.

Standard overall length:

Intake

126.85 – 127.45 mm (4.9941 – 5.0177 in.)

Exhaust

126.83 – 127.43 mm (4.9933 – 5.0169 in.)

Minimum overall length:

Intake

126.85 mm (4.9941 in.)

Exhaust

126.83 mm (4.9933 in.)

If the overall length is less than minimum, replace the valve.

- (d) Check the valve stem tip for wear.

If the valve stem tip is worn, replace the valve.

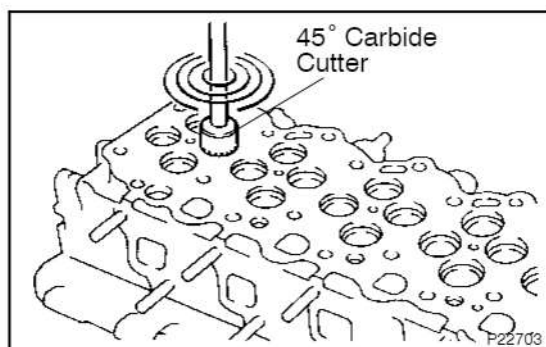

7. INSPECT AND CLEAN VALVE SEATS

- (a) Using a 45° carbide cutter, resurface the valve seats.
Remove only enough metal to clean the seats.

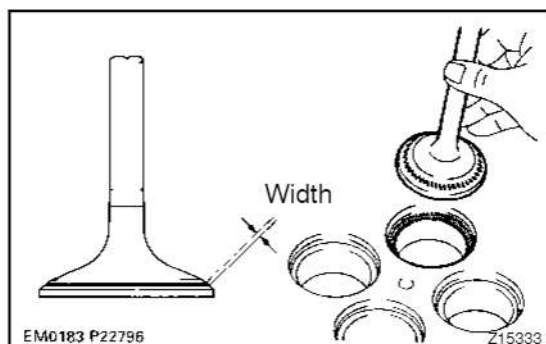

- (b) Check the valve seating position.
Apply a light coat of prussian blue (or white lead) to the valve face. Lightly press the valve against the seat. Do not rotate valve.

- (c) Check the valve face and seat for the following:
- If blue appears 360° around the valve face, the valve is concentric. If not, replace the valve.
 - If blue appears 360° around the valve seat, the guide and face are concentric. If not, resurface the seat.
 - Check that the seat contact is in the middle of the valve face with the following width:

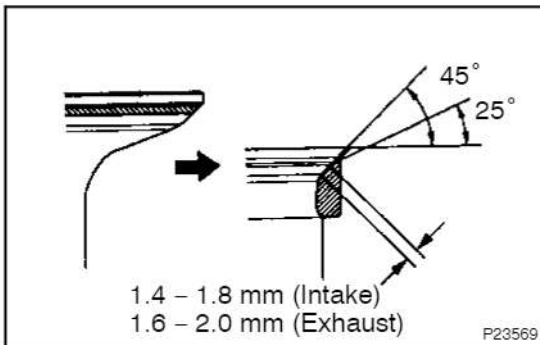
Intake**1.4 – 1.8 mm (0.055 – 0.071 in.)****Exhaust****1.6 – 2.0 mm (0.063 – 0.079 in.)**

If not, correct the valve seats as follows:

- (1) If the seating is too high on the valve face, use 25° and 45° cutters to correct the seat.

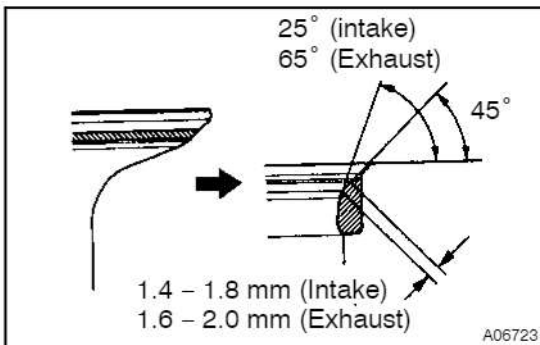

- (2) If the seating is too low on the valve face, use 70° (intake) or 65° (exhaust) and 45° cutters to correct the seat.

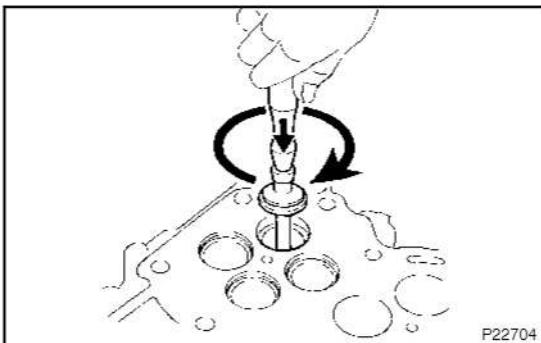

- (d) Hand-lap the valve and valve seat with an abrasive compound.
- (e) After hand-lapping, clean the valve and valve seat.

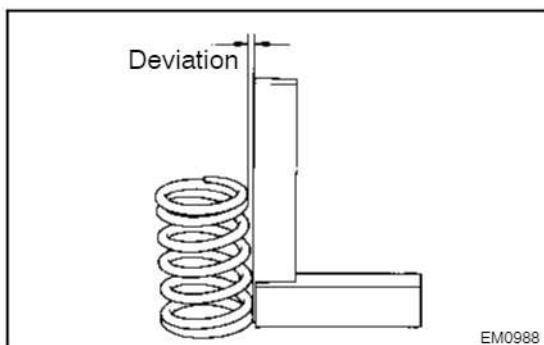

8. INSPECT VALVE SPRINGS

- (a) Using a steel square, measure the deviation of the valve spring.

Maximum deviation: 2.0 mm (0.079 in.)

If the deviation is greater than maximum, replace the valve spring.

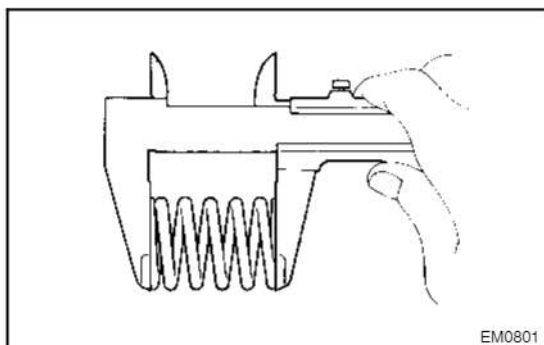

- (b) Using vernier calipers, measure the free length of the valve spring.

Free length: 49.6 mm (1.9527 in.)

If the free length is not as specified, replace the valve spring.

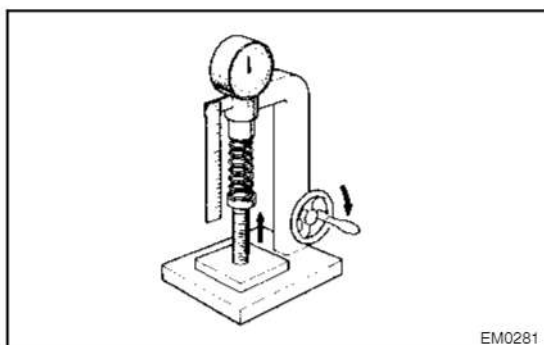

- (c) Using a spring tester, measure the tension of the valve spring at the specified installed length.

Installed tension:

237 - 263 N (24.2 - 26.8 kgf, 53.4 - 59.1 lbf)

at 39.5 mm (1.555 in.)

If the installed tension is not as specified, replace the valve spring.

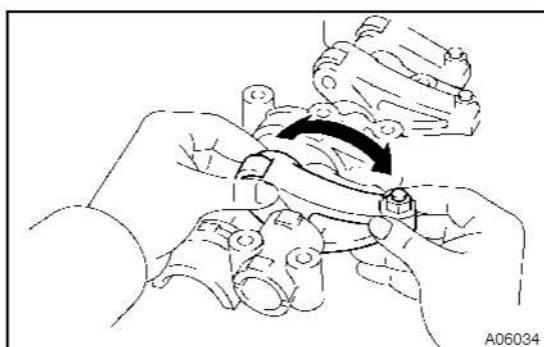

9. INSPECT VALVE ROCKER ARM AND SHAFT

- (a) Check that each rocker arm turns smoothly. If movement is felt, disassemble and check.
- (b) Remove the bolt, and disassemble the parts.

HINT:

Arrange the disassembled parts in correct order.

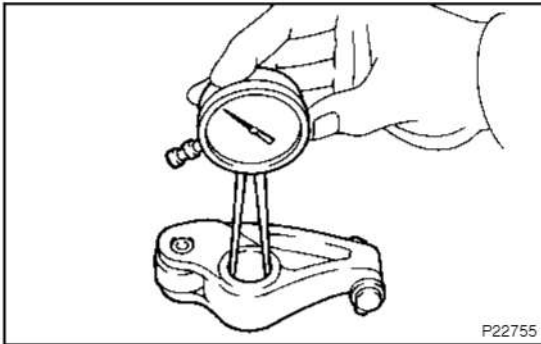
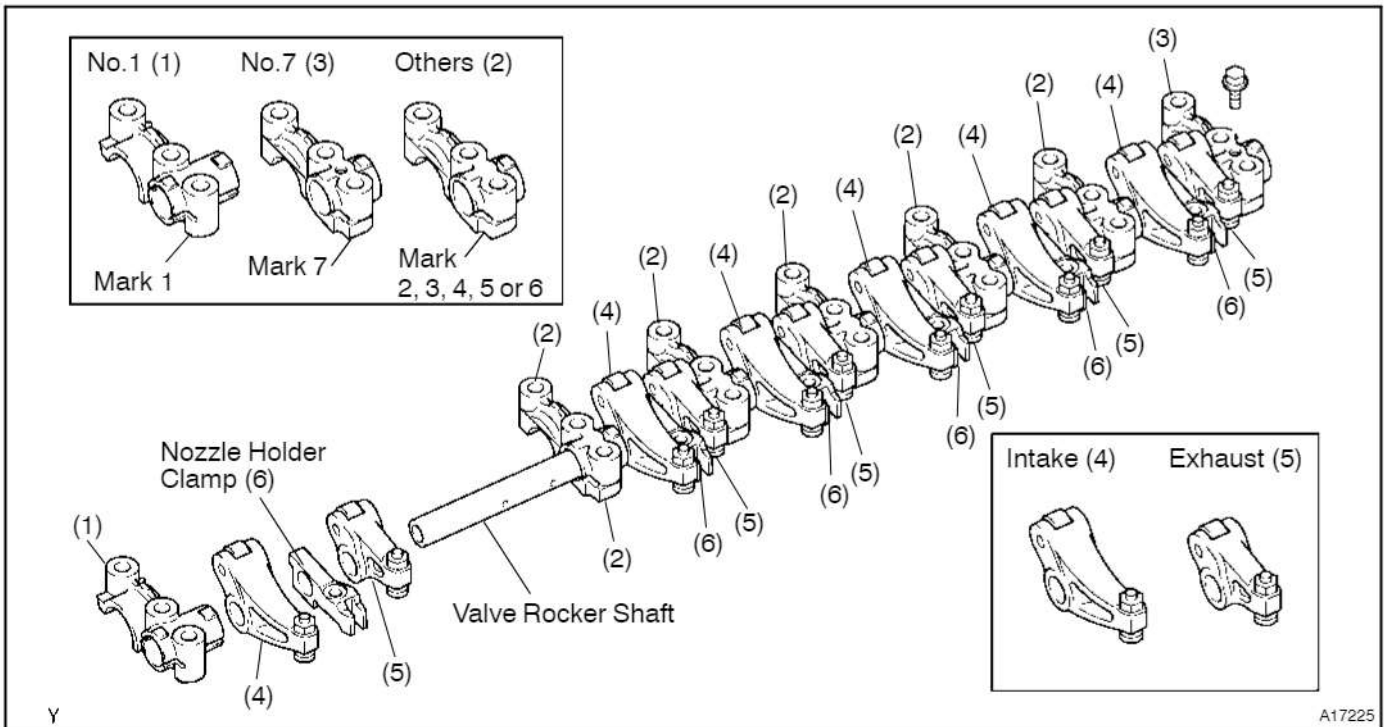

- (c) Using a caliper gauge, measure the inside diameter of the rocker arm.

Rocker arm inside diameter:

20.012 – 20.033 mm (0.7879 – 0.7887 in.)

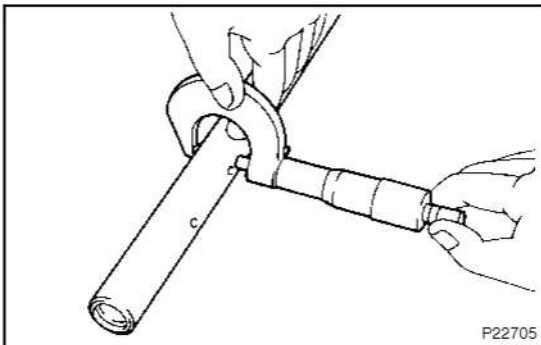

- (d) Using a micrometer, measure the diameter of the rocker arm shaft.

Shaft diameter:

19.972 – 19.993 mm (0.7863 – 0.7871 in.)

- (e) Subtract the rocker arm shaft measurement from the rocker arm measurement.

Standard oil clearance:

0.019 – 0.061 mm (0.0007 – 0.0024 in.)

Maximum oil clearance: 0.10 mm (0.0039 in.)

If the clearance is greater than maximum, replace the rocker shaft and shaft.

- (f) Assemble the parts as shown in the illustration (See step (b) above).

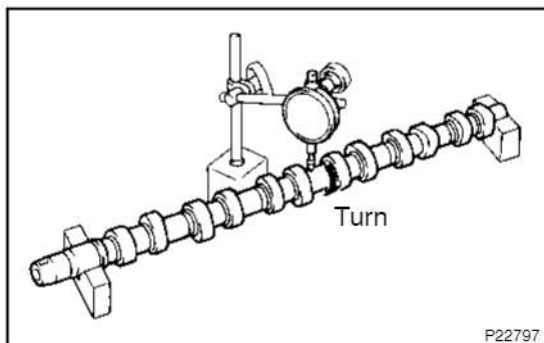

10. INSPECT CAMSHAFTS AND BEARINGS

- (a) Inspect camshaft for runout
- (1) Place the camshaft on V-blocks.
 - (2) Using a dial indicator, measure the circle runout at the center journal.

Maximum circle runout: 0.10 mm (0.0039 in.)

If the circle runout is greater than maximum, replace the camshaft.

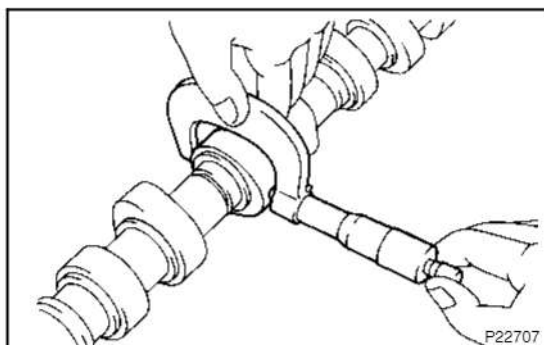

- (b) Inspect cam lobes
Using a micrometer, measure the cam lobe height.

Standard cam lobe height:

Intake

48.203 – 48.303 mm (1.8978 – 1.9017 in.)

Exhaust

50.734 – 50.834 mm (1.9974 – 2.0013 in.)

Minimum cam lobe height:

Intake

47.998 mm (1.8897 in.)

Exhaust

50.234 mm (1.9777 in.)

If the cam lobe height is less than minimum, replace the camshaft.

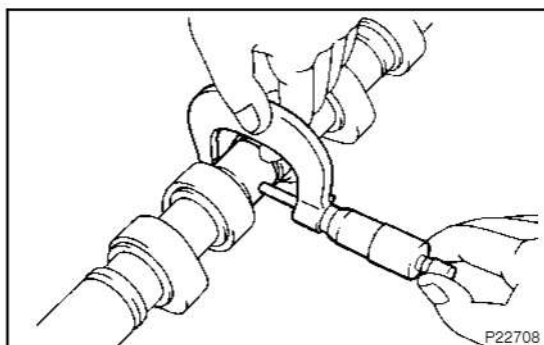

- (c) Inspect camshaft journals
Using a micrometer, measure the journal diameter.

Journal diameter:

No.1

34.969 – 34.985 mm (1.3767 – 1.3774 in.)

others

27.986 – 28.002 mm (1.1018 – 1.1024 in.)

If the journal diameter is not as specified, check the oil clearance.

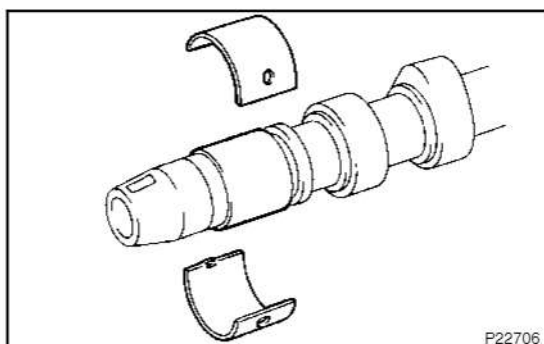

- (d) Inspect camshaft bearings
Check the bearings for flaking and scoring.

If the bearings are damaged, replace the bearing caps and cylinder head as a set.

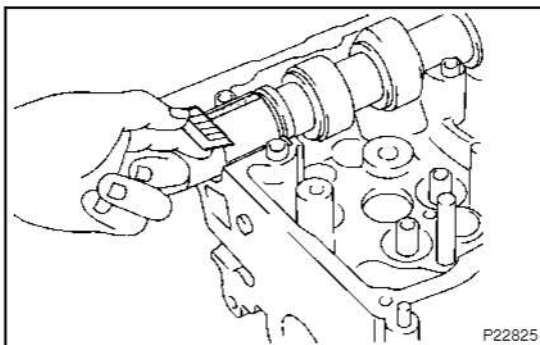
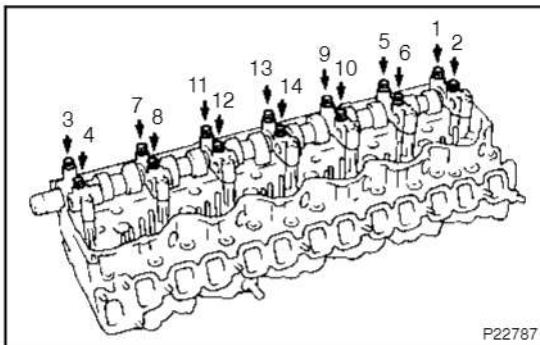
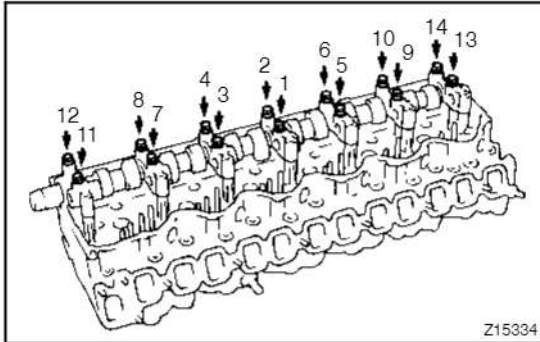
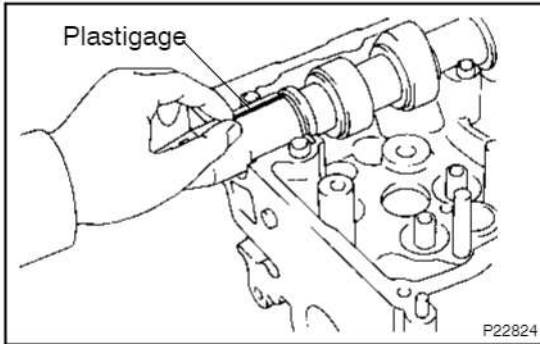

- (e) Inspect camshaft journal oil clearance
- (1) Clean the bearing caps and camshaft journals.
 - (2) Place the camshaft on the cylinder head.
 - (3) Lay a strip of Plastigage across each of the camshaft journals.
 - (4) Remove the 7 bearing caps from the valve rocker shaft. (See step 9)

- (5) Install the 7 bearing caps with the 14 bolts. Uniformly tighten the bolts in several passes, in the sequence shown.

Torque: 25 N·m (250 kgf·cm, 18 ft·lbf)

NOTICE:

Do not turn the camshaft.

- (6) Uniformly loosen and remove the 14 bolts in several passes, in the sequence shown.
- (7) Remove the 7 bearing caps.

- (8) Measure the Plastigage at its widest point.

Standard oil clearance:

No.1

0.022 – 0.074 mm (0.0009 – 0.0029 in.)

Others

0.023 – 0.075 mm (0.0009 – 0.0030 in.)

Maximum oil clearance: 0.10 mm (0.0039 in.)

If the oil clearance is greater than maximum, replace the camshaft. If necessary, replace the bearing caps and cylinder head as a set.

- (9) Completely remove the Plastigage.
- (10) Install the 7 bearing caps to the valve rocker shaft (See item 9 (b) above).

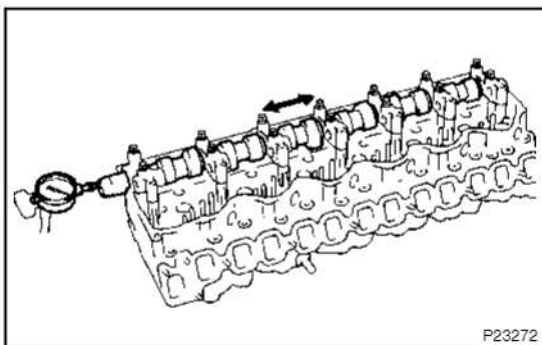

- (f) Inspect camshaft thrust clearance
- (1) Install the camshaft.
(See procedure in item e above)
 - (2) Using a dial indicator, measure the thrust clearance while moving the camshaft back and forth.

Standard thrust clearance:**0.10 - 0.20 mm (0.0039 - 0.0079 in.)****Maximum thrust clearance: 0.30 mm (0.0118 in.)**

If the thrust clearance is greater than maximum, replace the camshaft. If necessary, replace the bearing caps and cylinder head as a set.

- (3) Remove the camshaft.

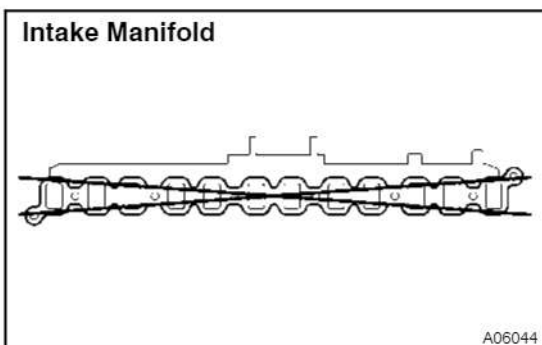
**11. INSPECT INTAKE MANIFOLD**

Using a precision straight edge and feeler gauge, measure the surface contacting the cylinder head for warpage.

Maximum warpage: 0.40 mm (0.0157 in.)

If warpage is greater than maximum, replace the manifold.

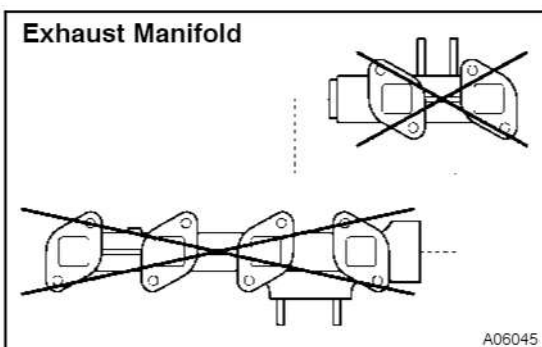
**12. INSPECT EXHAUST MANIFOLD**

Using a precision straight edge and feeler gauge, measure the surface contacting the cylinder head for warpage.

Maximum warpage: 0.40 mm (0.0157 in.)

If warpage is greater than maximum, replace the manifold.

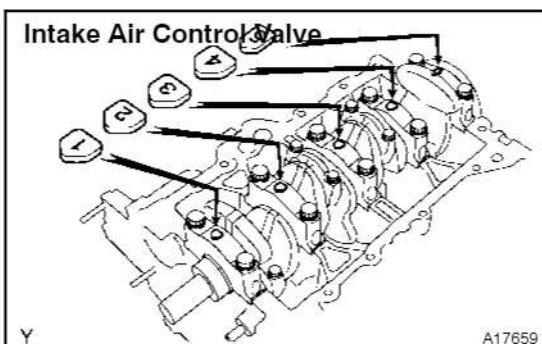
**13. INSPECT INTAKE AIR CONTROL VALVE**

Using a precision straight edge and feeler gauge, measure the surface contacting the intake air control valve.

Maximum warpage: 0.40 mm (0.0157 in.)

If warpage is greater than maximum, replace the intake air control valve.

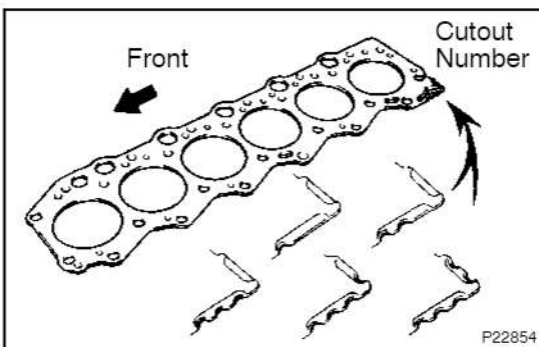
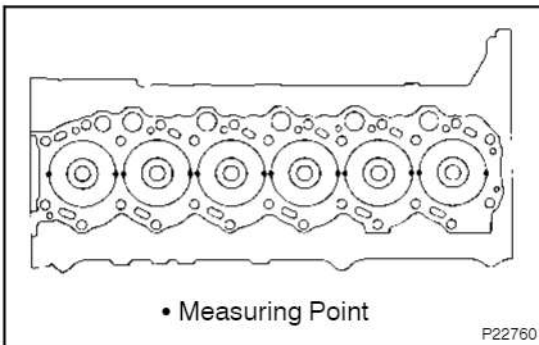
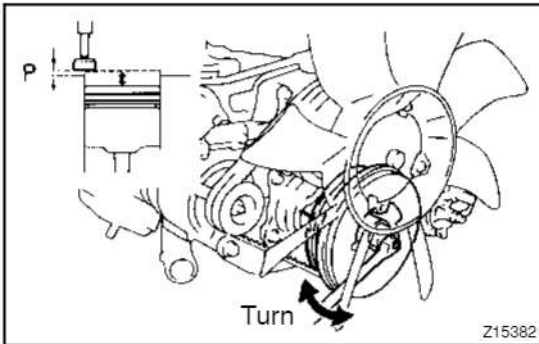
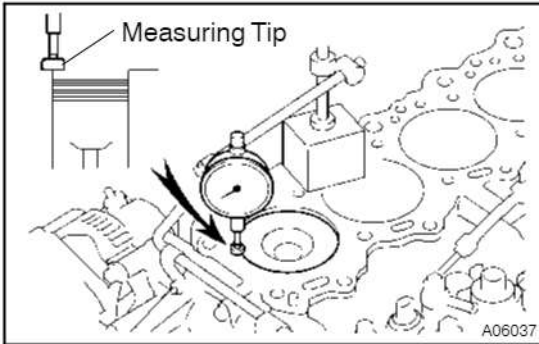

INSTALLATION

1. CHECK PISTON PROTRUSION AND SELECT CYLINDER HEAD GASKET

Check piston protrusions for each cylinder

- (1) Clean the cylinder block with solvent.
- (2) Set the piston of the cylinder to be measured to slightly before TDC.
- (3) Place a dial indicator on the cylinder block, and set the dial indicator at 0 mm (0 in.).

HINT:

- Use a dial indicator measuring tip as shown in the illustration.
- Make sure that the measuring tip is square to the cylinder block gasket surface and piston head when taking the measurements.
- (4) Find where the piston head protrudes most by slowly turning the crankshaft clockwise and counter-clockwise.
- (5) Measure each cylinder at 2 places as shown in the illustration, making a total of 12 measurements.
- (6) For the piston protrusion value of each cylinder, use the average of the 2 measurements of each cylinder.

Protrusion (P): 0.175 – 0.425 mm (0.0069 – 0.0167 in.)

When removing piston and connecting rod assembly:

If the protrusion is not as specified, remove the piston and connecting rod assembly and reinstall it.

(See Pub. No. RM617E, on page EM-121)

2. SELECT NEW CYLINDER HEAD GASKET

HINT:

There are 5 types of gasket (cutout number 1 to 5) installed at factory, but only 3 types for supply parts (cutout number 1, 3 and 5), so when replacing the gasket select from one of 3 types above.

New installed cylinder head gasket thickness:

Cutout number 1: 0.85 – 0.95 mm (0.0335 – 0.0374 in.)

Cutout number 3: 0.95 – 1.05 mm (0.0374 – 0.0414 in.)

Cutout number 5: 1.05 – 1.15 mm (0.0414 – 0.0453 in.)

Select the largest piston protrusion value from the measurements made, then select a new appropriate gasket according to the table below.

Piston protrusion	Gasket size
0.225 mm (0.0089 in.) or less	Use 1
0.226 – 0.325 mm (0.0089 – 0.0128 in.)	Use 3
0.326 mm (0.0128 in.) or more	Use 5

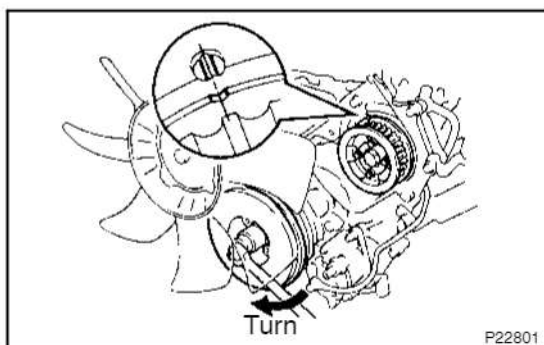

3. SET NO.1 CYLINDER TO BDC/COMPRESSION

Turn the crankshaft pulley, and align the timing mark of the No.2 camshaft timing pulley, with the BDC mark of the timing gear cover.

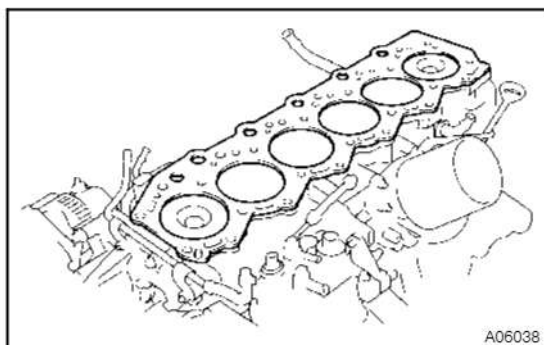

4. INSTALL CYLINDER HEAD

(a) Place cylinder on cylinder block

- (1) Place a new cylinder head gasket in position on the cylinder block.

NOTICE:

Be careful of the installation direction.

- (2) Place the cylinder head in position on the cylinder head gasket.

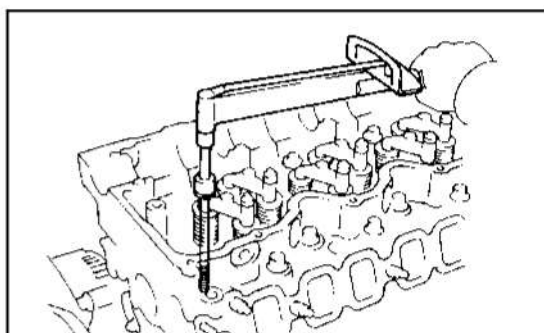

(b) Install cylinder head bolts

HINT:

- The cylinder head bolts are tightened in 3 progressive steps (steps (b), (d) and (e)).
- If any bolts is broke or deformed, replace it.
 - (1) Apply a light coat of engine oil on the threads and under the heads of the cylinder head bolts.
 - (2) Install and uniformly tighten the 26 cylinder head bolts in several passes, in the sequence shown.

Torque: 68.6 N·m (700 kgf·cm, 51 ft·lbf)

HINT:

Each bolt length is indicated in the illustration.

Bolt length:

A 121.5 mm (4.783 in.)

B 133.5 mm (5.256 in.)

If any one of the cylinder head bolts does not meet the torque specification, replace the cylinder head bolt.

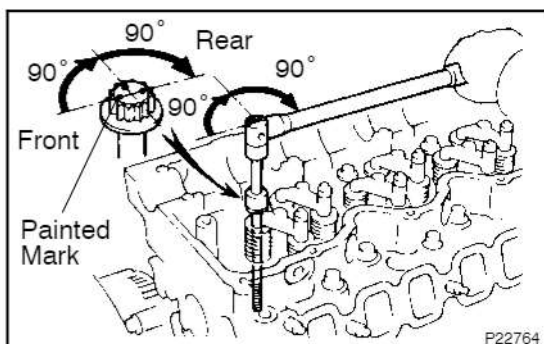
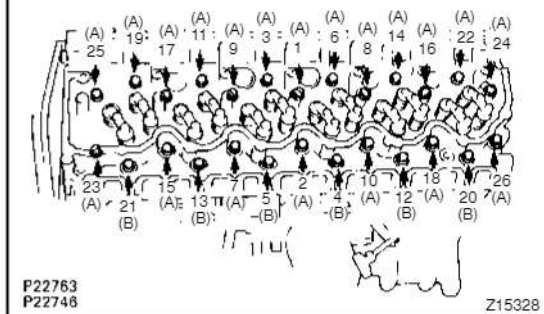

- (c) Mark the front of the cylinder head bolt with paint.
- (d) Retighten the cylinder head bolts 90° in the numerical order shown.
- (e) Retighten cylinder head bolts by an additional 90°.
- (f) Check that the painted mark is now facing rearward.
- (g) Connect the water bypass hose (from the injection pump) to the cylinder head.

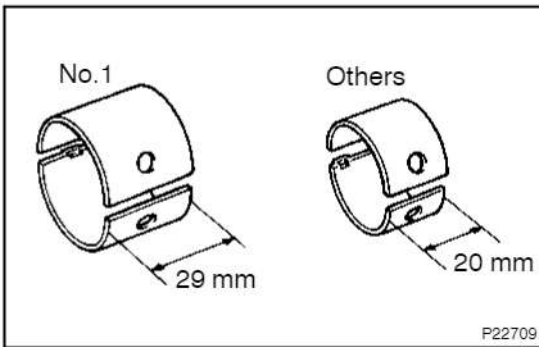

5. INSTALL CAMSHAFT, CAMSHAFT BEARING CAPS VALVE ROCKER ARMS NOZZLE HOLDER CLAMPS AND ROCKER SHAFT ASSEMBLY

HINT:

Camshaft bearings come in widths of 20 mm (0.79 in.) and 29 mm (1.14 in.). Install the 29 mm (0.886 in.) bearings in the No.1 cylinder head journal positions with the camshaft bearing cap. Install the 20 mm (0.79 in.) bearings in the other positions.

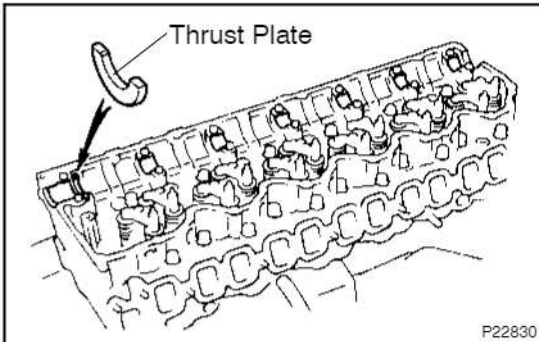

- (a) Install the 7 lower camshaft bearings and thrust plate.

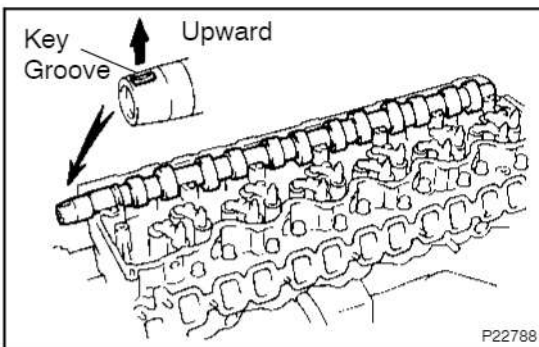

- (b) Place the camshaft on the cylinder head, facing the key groove upward.
- (c) Install the 7 upper camshaft bearings to the bearing caps.

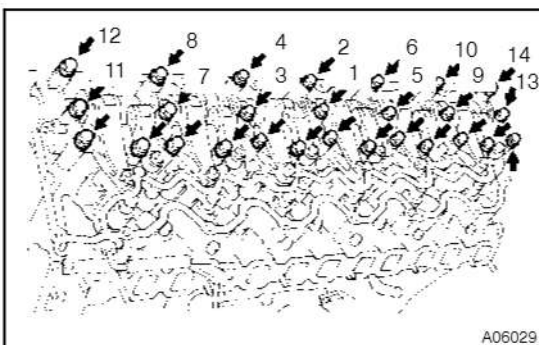

- (d) Install the 7 bearing caps, 12 rocker arms, 6 holder clamps and rocker shaft assembly.
- (e) Install and uniformly tighten the 14 bearing cap bolts in several passes, in the sequence shown.

Torque: 25 N·m (250 kgf·cm, 18 ft·lbf)

- (f) Install the 13 others bolts.

Torque: 25 N·m (250 kgf·cm, 18 ft·lbf)

6. INSTALL INJECTION NOZZLES

(See Pub. No. RM617E, on page FU-44)

7. INSTALL CAMSHAFT OIL SEAL RETAINER

- (a) Remove any old packing (FIPG) material and be careful not to drop any oil on the contact surfaces of the oil seal retainer and cylinder head.
- Using a razor blade and gasket scraper, remove all the oil packing (FIPG) material from the gasket surfaces and sealing groove.
 - Thoroughly clean all components to remove all the loose material.

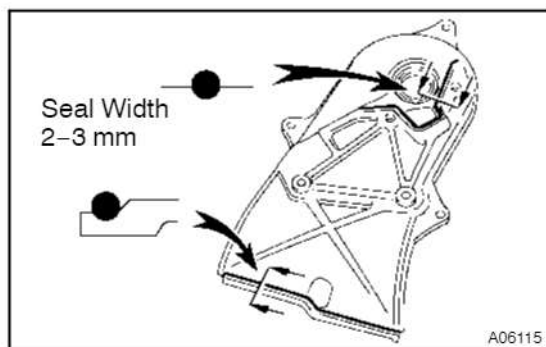

- Using a non-residue solvent, clean both sealing surfaces.
- (b) Apply seal packing to the oil seal retainer as shown in the illustration.

Seal packing: Part No. 08826-00080 or equivalent

- Install a nozzle that has been cut to a 2-3 mm (0.08 - 0.12 in.) opening.
- Parts must be assembled within 5 minutes of application. Otherwise the material must be removed and reapplied.
- Immediately remove nozzle from the tube and reinstall cap.

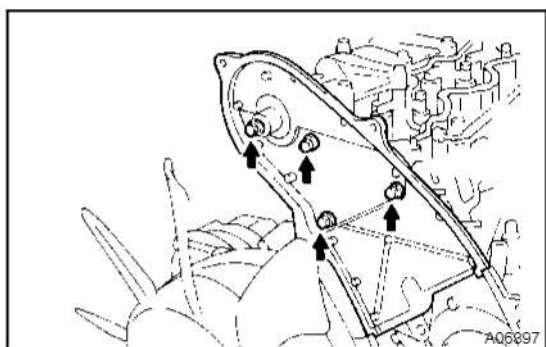

- (c) Install the oil seal retainer with the 4 bolts. Uniformly tighten the bolts in several passes.

Torque: 19.6 N·m (200 kgf·cm, 14 ft·lbf)

8. INSTALL PULLEYS AND TIMING BELT

(See page EM-5)

9. CHECK AND ADJUST VALVE CLEARANCE

(See Pub. No. RM617E, on page EM-9)

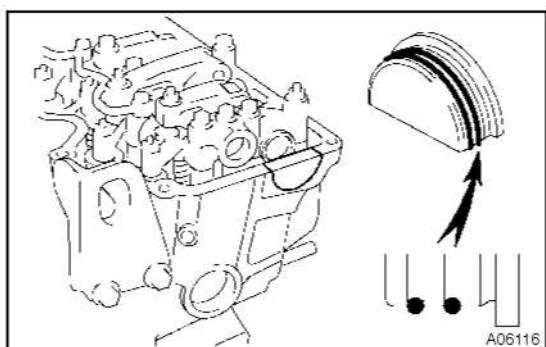

10. INSTALL SEMI-CIRCULAR PLUG

- (a) Remove any old packing (FIPG) material.
- (b) Apply seal packing to the semi-circular plug as shown in the illustration.

Seal packing: Part No. 08826-00080 or equivalent

- (c) Install the semi-circular plug to the cylinder head.

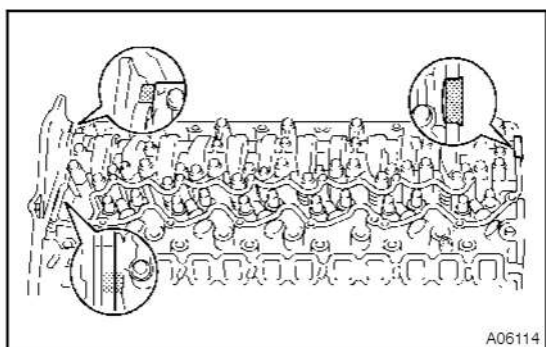

11. INSTALL NO.1 CYLINDER HEAD COVER

- (a) Remove any old packing (FIPG) material.
- (b) Apply seal packing to the No.1 cylinder head as shown in the illustration.

Seal packing: Part No. 08826-00080 or equivalent

- (c) Install the gasket to the No.1 cylinder head cover.
- (d) Install the No.1 cylinder head cover with 17 new seal washers and 17 bolts. Uniformly tighten the bolts in several passes.

Torque: 8 N·m (80 kgf·cm, 71 in.·lbf)

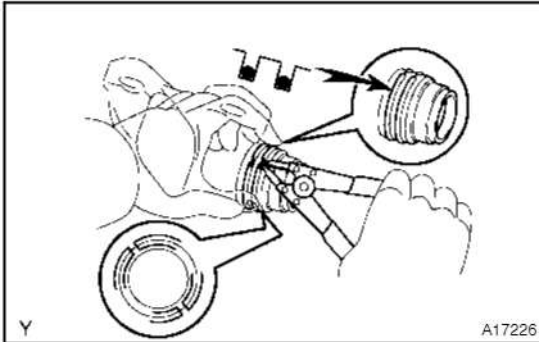
12. INSTALL 2 ENGINE HANGERS**Torque: 39.2 N·m (400 kgf·cm, 29 ft·lbf)****13. ASSEMBLE EXHAUST MANIFOLDS**

- (a) Install 2 new O-rings to the rear exhaust manifold.
- (b) Using snap ring pliers, install the 2 rings to the rear exhaust manifold.
- (c) Position the rings so that the ring ends are as shown.

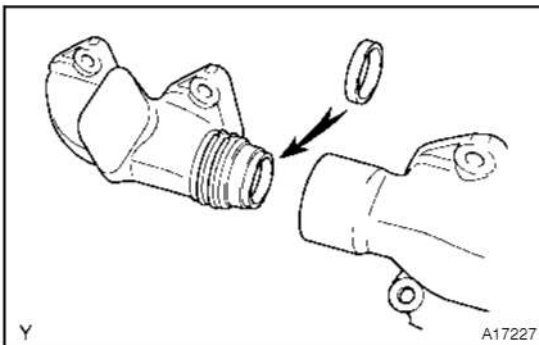
NOTICE:**Do not align the ring ends.**

- (d) Install the collar the rear exhaust manifold.
- (e) Assemble the front and rear exhaust manifolds.

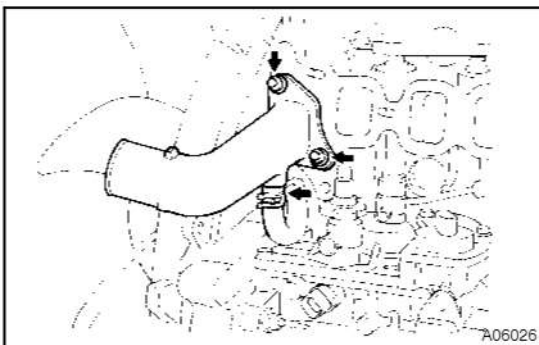
14. INSTALL EXHAUST MANIFOLD TO TURBOCHARGER
(See page TC-10)**15. INSTALL TURBOCHARGER AND EXHAUST MANIFOLDS ASSEMBLY**
(See page TC-10)**16. INSTALL WATER OUTLET**

- (a) Install a new gasket and the water outlet.
- (b) Connect the water bypass hose to the water outlet.
- (c) Install the water outlet with the 2 nuts.

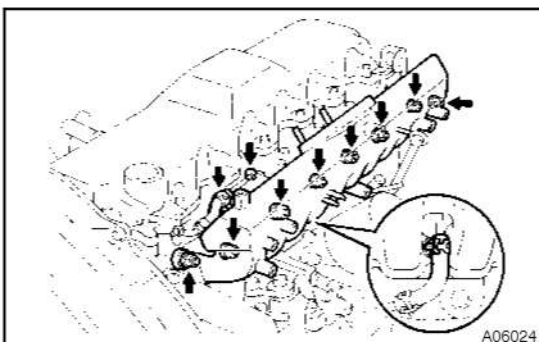
Torque: 19.6 N·m (200 kgf·cm, 14 ft·lbf)**17. INSTALL INTAKE AIR CONTROL VALVE AND INTAKE MANIFOLD**

- (a) Install the 4 gaskets, intake air control valve and intake manifold with the 8 seal washers and 8 nuts.

Torque: 19.6 N·m (200 kgf·cm, 14 ft·lbf)

- (b) Connect the fuel hose to the injection pump.

18. INSTALL 2 INTAKE MANIFOLD INSULATORS**19. INSTALL INJECTION PIPES**

(See Pub. No. RM617E, on page FU-44)

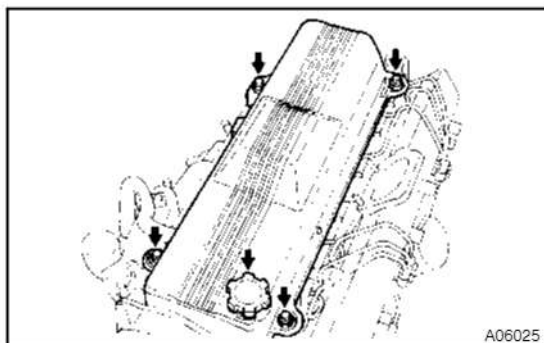
**20. INSTALL NO.2 CYLINDER HEAD COVER**

- (a) Install the No.2 cylinder head cover with the 4 bolts.
- (b) Install the oil filler cap.

21. INSTALL EGR COOLER PIPE

Install a new gasket and EGR cooler pipe with the 2 nuts to the intake pipe assembly.

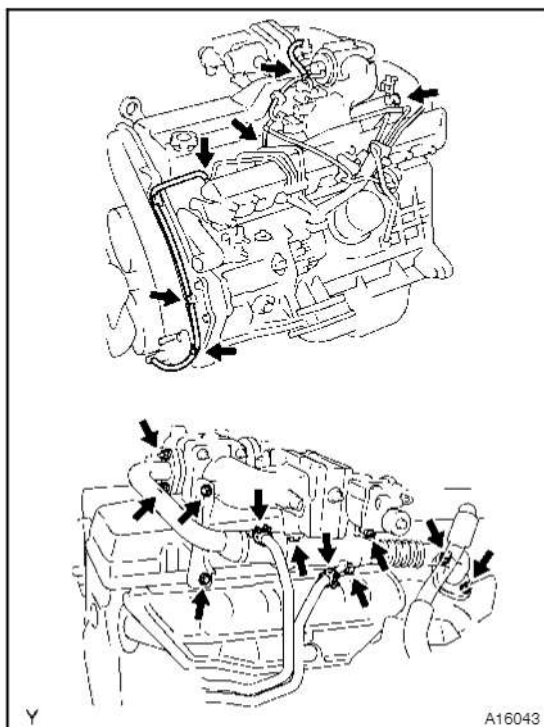
**22. INSTALL INTAKE PIPE ASSEMBLY**

- (a) Install the intake pipe assembly with the 2 bolts and 2 nuts.
- (b) Install a new gasket, connect the EGR cooler pipe with the 2 nuts to the exhaust manifold.
- (c) Install the 2 intake pipe assembly brackets with the 4 bolts.
- (d) Connect the 2 water hoses to the EGR cooler pipe.
- (e) Connect the 5 vacuum hoses to the No.2 cylinder head cover.
- (f) Connect the vacuum hose to the clamp and timing belt cover.

23. FILL WITH ENGINE COOLANT**24. START ENGINE AND CHECK FOR LEAKS****25. RECHECK ENGINE COOLANT LEVEL AND OIL LEVEL**

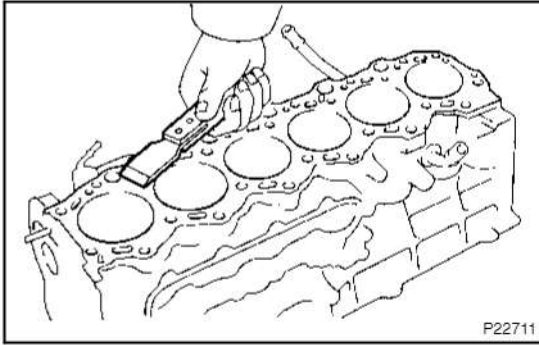

P22711

CYLINDER BLOCK INSPECTION

EM1T1-01

1. CLEAN CYLINDER BLOCK

- (a) Remove gasket material
Using a gasket scraper, remove all the gasket material from the top surface of the cylinder block.
- (b) Clean cylinder block
Using a soft brush and solvent, thoroughly clean the cylinder block.

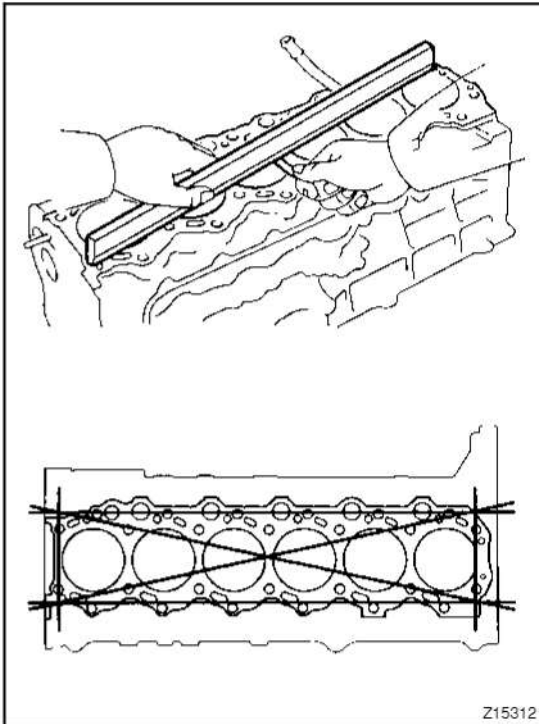

Z15312

2. INSPECT TOP SURFACE OF CYLINDER BLOCK FOR FLATNESS

Using a precision straight edge and feeler gauge, measure the surfaces contacting the cylinder head gasket for warpage.

Maximum warpage: 0.20 mm (0.0079 in.)

If warpage is greater than maximum, replace the cylinder block.

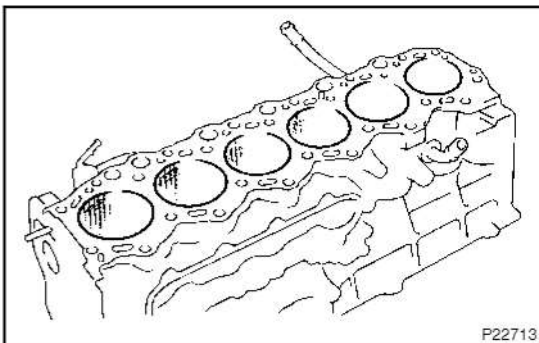

P22713

3. INSPECT CYLINDER FOR VERTICAL SCRATCHES

Visually check the cylinder for vertical scratches.

If deep scratches are present, rebore all the 6 cylinders. If necessary, replace the cylinder block.

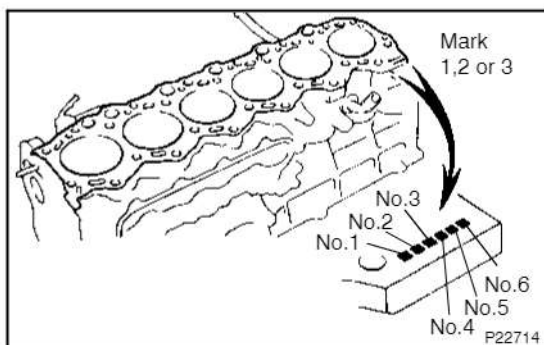

4. INSPECT CYLINDER BORE DIAMETER

HINT:

There are 3 sizes of the standard cylinder bore diameter, marked "1", "2" and "3" accordingly. The mark stamped on the top of the cylinder block.

Using a cylinder gauge, measure the cylinder bore diameter at positions A, B and C in the thrust and axial directions.

Standard diameter:

STD

Mark "1"

94.000 – 94.010 mm (3.7001 – 3.7012 in.)

Mark "2"

94.010 – 94.020 mm (3.7012 – 3.7016 in.)

Mark "3"

94.020 – 94.030 mm (3.7016 – 3.7020 in.)

Maximum diameter:

STD

94.23 mm (3.7098 in.)

O/S 0.50

94.73 mm (3.7295 in.)

If the diameter is greater than maximum, rebore all the 6 cylinders. If necessary, replace the cylinder block.

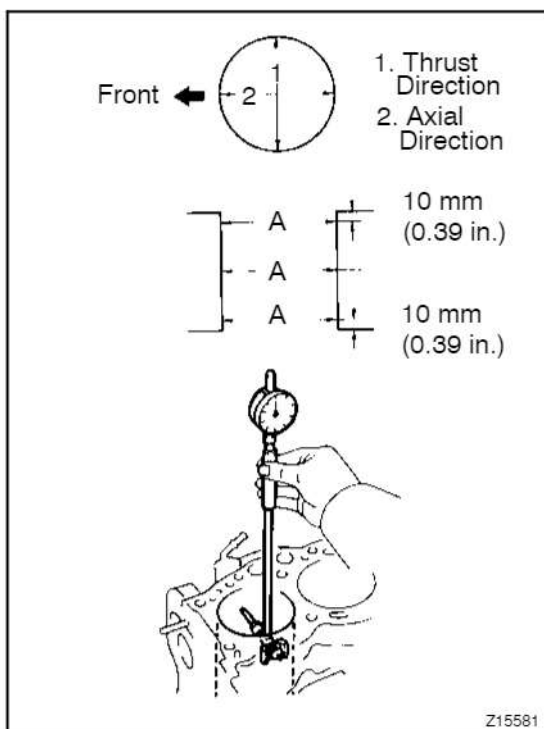

5. REMOVE CYLINDER RIDGE

If the wear is less than 0.2 mm (0.008 in.), using a ridge reamer, grind the top of the cylinder.

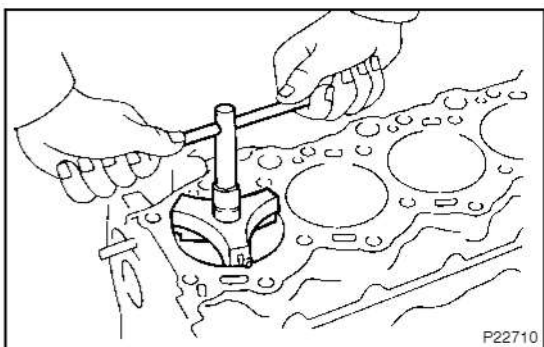

6. INSPECT MAIN BEARING CAP BOLTS

Using vernier calipers, measure the thread outside diameter at the measuring point.

Standard diameter:

11.80 – 12.00 mm (0.4646 – 0.4724 in.)

Minimum diameter: 11.50 mm (0.4528 in.)

If the diameter is less than minimum, replace the bolt.

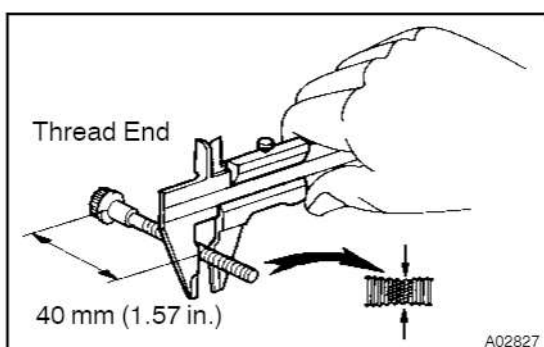

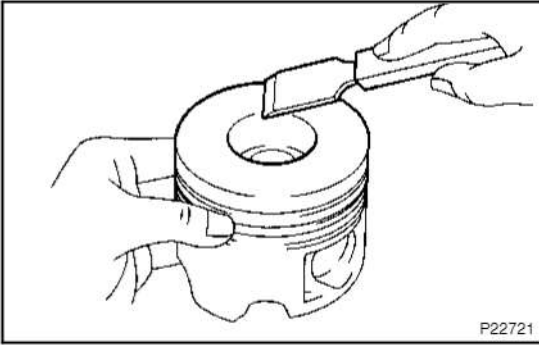

7. CLEAN PISTON

- (a) Using a gasket scraper, remove the carbon from the piston top.

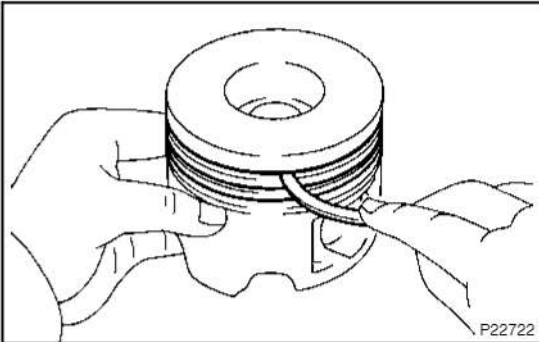

- (b) Using a groove cleaning tool or broken ring, clean the piston ring grooves.

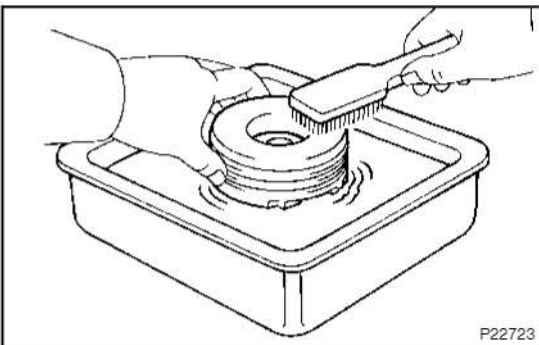

- (c) Using solvent and a brush, thoroughly clean the piston.

NOTICE:

Do not use a wire brush.

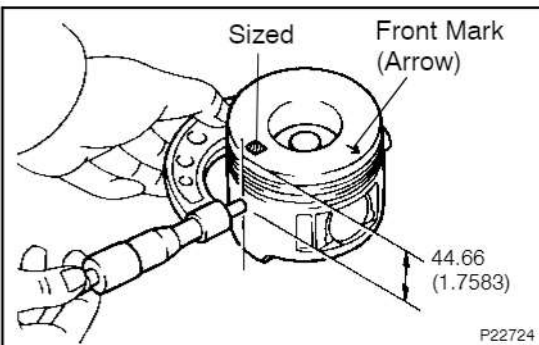

8. INSPECT PISTON AND PISTON RING

- (a) Inspect piston diameter and oil clearance

HINT:

There are 3 sizes of the standard piston diameter, marked "1", "2" and "3" accordingly. The mark is stamped on the piston top.

- (1) Using a micrometer, measure the piston diameter at right angles to the piston pin center line from the piston head.

Piston diameter:

Mark 1	93.870 - 93.880 mm (3.69566 - 3.69606 in.)
Mark 2	93.881 - 93.890 mm (3.69609 - 3.69645 in.)
Mark 3	93.891 - 93.900 mm (3.69649 - 3.69684 in.)
O/S 0.50	94.370 - 94.400 mm (3.71535 - 3.71653 in.)

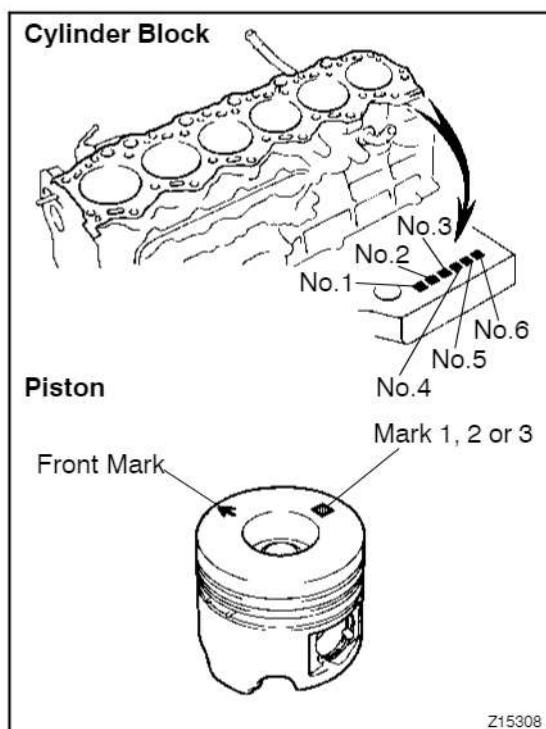

- (2) Measure the cylinder bore diameter in the thrust directions. (See step 4)
- (3) Subtract the piston diameter measurement from the cylinder bore diameter measurement.

Standard oil clearance:**0.070 – 0.090 mm (0.0028 – 0.0035 in.)****Maximum oil clearance:****0.090 mm (0.0035 in.)**

If the oil clearance is greater than maximum, replace all the 6 pistons and rebores all the 6 cylinders. If necessary, replace the cylinder block.

HINT:

Use a piston with the same number mark as the cylinder bore diameter marked on the cylinder block.

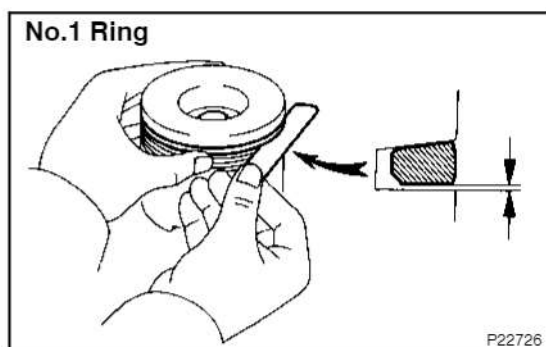

- (b) Inspect piston ring groove clearance

- (1) No.1 Ring:

Install a new piston ring to the piston. Using a feeler gauge, measure the clearance between the piston ring and the wall of the ring groove.

Standard groove clearance:**0.070 – 0.110 mm (0.0028 – 0.0043 in.)****Maximum groove clearance: 0.20 mm (0.0079 in.)**

If the clearance is greater than maximum, replace the piston.

- (2) No.2 and Oil Rings:

Using a feeler gauge, measure the clearance between a new piston ring and the wall of the ring groove.

Standard groove clearance:**No.2:****0.040 – 0.080 mm (0.0016 – 0.0031 in.)****Maximum groove clearance: 0.020 mm (0.0079 in.)****Standard groove clearance:****Oil: 0.030 – 0.070 mm (0.0012 – 0.0028 in)****Maximum groove clearance: 0.20 mm (0.0079 in)**

If the clearance is greater than maximum, replace the piston.

- (c) Inspect piston ring end gap

- (1) Insert the piston ring into the cylinder bore.
- (2) Using a piston, push the piston ring a little beyond the bottom of the ring travel, 130 mm (5.12 in.) from the top of the cylinder block.

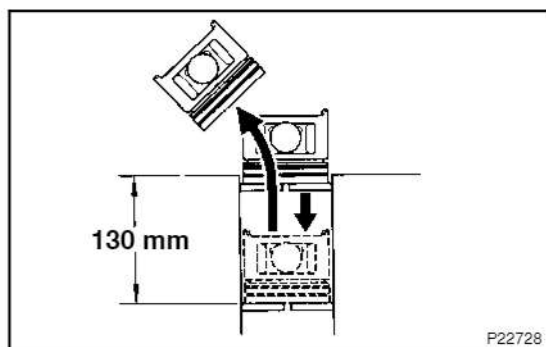
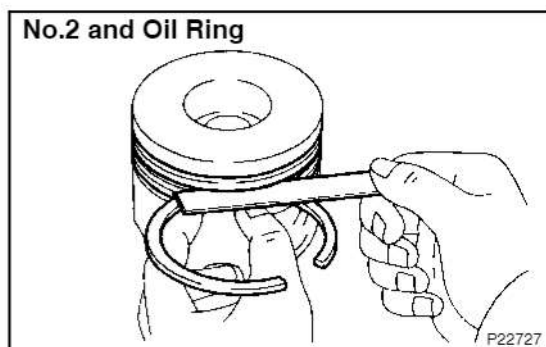

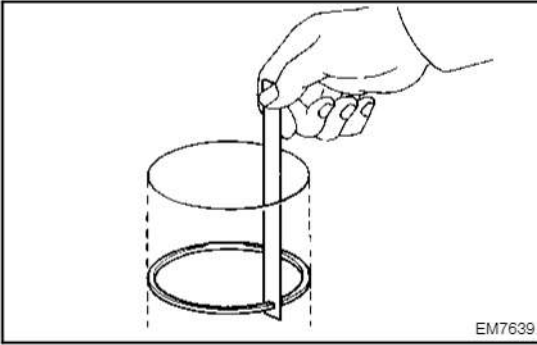

(3) Using a feeler gauge, measure the end gap.

Standard end gap:

No.1:

0.270 – 0.330 mm (0.0106 – 0.0130 in.)

No.2: 0.400 – 0.550 mm (0.0157 – 0.0119 in)

Oil: 0.200 – 0.500 mm (0.0079 – 0.0157 in.)

Maximum end gap:

No.1: 0.850 mm (0.0335 in.)

No.2: 0.900 mm (0.0354 in.)

Oil: 0.880 mm (0.0346 in.)

If the end gap is greater than maximum, replace the piston ring.
If the end gap is greater than maximum, even with a new piston ring, rebore all the 6 cylinders or replace the cylinder block.

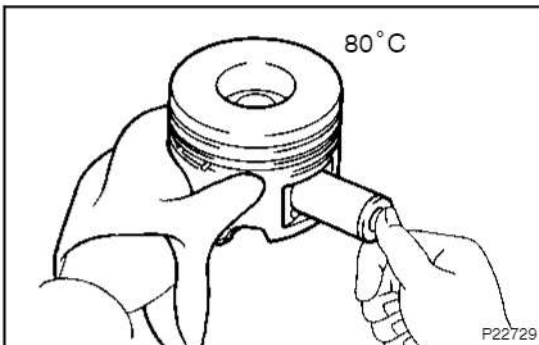

9. INSPECT PISTON PIN FIT

At 80°C (176°F), you should be able to push the piston pin into the piston pin hole with your thumb.

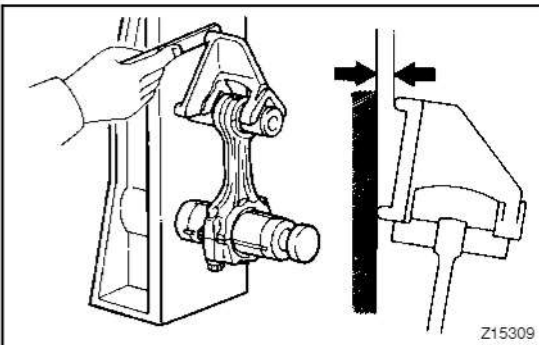

10. INSPECT CONNECTING ROD

(a) Inspect connecting rod alignment

Using a rod aligner and feeler gauge, check the connecting rod alignment.

- Check for bend.

Maximum bend:

0.03 mm (0.0012 in.) per 100 mm (3.94 in.)

If bend is greater than maximum, replace the connecting rod assembly.

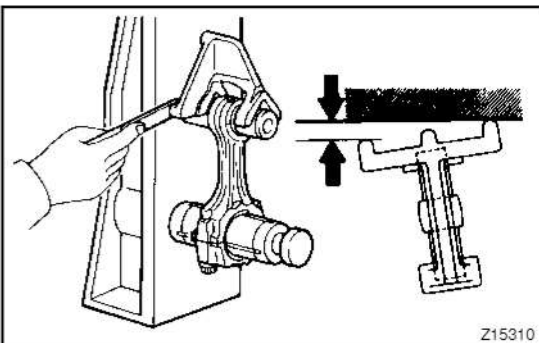

- Check for twist

Maximum twist:

0.15 mm (0.0059 in.) per 100 mm (3.94 in.)

If twist is greater than maximum, replace the connecting rod assembly.

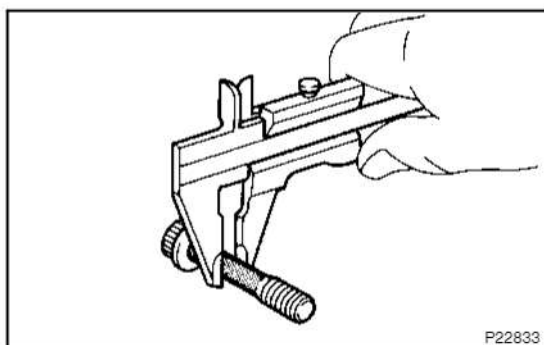

- (b) Inspect connecting rod bolts
Using vernier calipers, measure the tension portion diameter.

Standard diameter:

8.300 – 8.400 mm (0.3268 – 0.3307 in.)

Minimum diameter: 7.95 mm (0.3130 in.)

If the diameter is less than minimum, replace the connecting rod bolt.

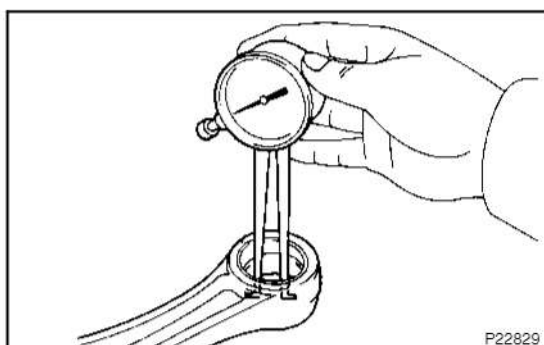

- (c) Inspect piston pin oil clearance
(1) Using caliper gauge, measure the inside diameter of the connecting rod bushing.

Bushing inside diameter:

33.008 – 33.020 mm (1.2995 – 1.3000 in.)

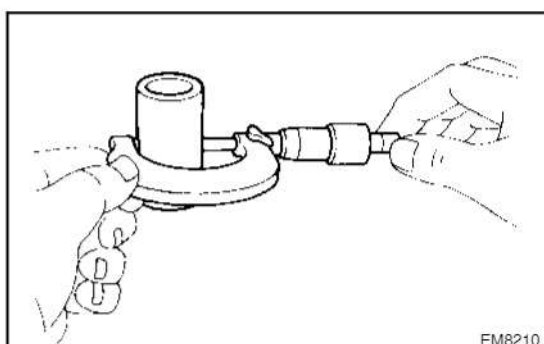

- (2) Using micrometer, measure the piston pin diameter.

Piston pin diameter:

33.000 – 33.012 mm (1.2992 – 1.2997 in.)

- (3) Subtract the piston pin diameter measurement from the bushing inside diameter measurement.

Standard oil clearance:

0.004 – 0.012 mm (0.0002 – 0.0005 in.)

Maximum oil clearance: 0.030 mm (0.0012 in.)

If the oil clearance is greater than maximum, replace the bushing. If necessary, replace the piston and piston pin as a set.

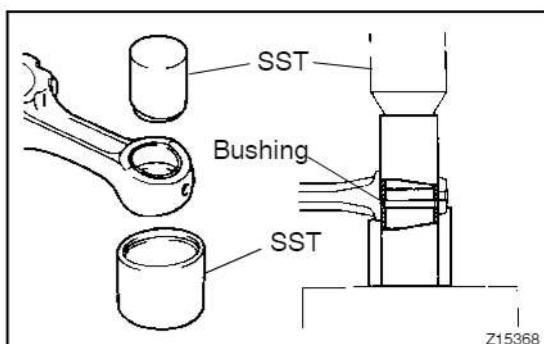

- (d) If necessary, replace connecting rod bushing
(1) Using SST and a press, press out the bushing.
SST 09222-17011 (09222-05021, 09222-05041)

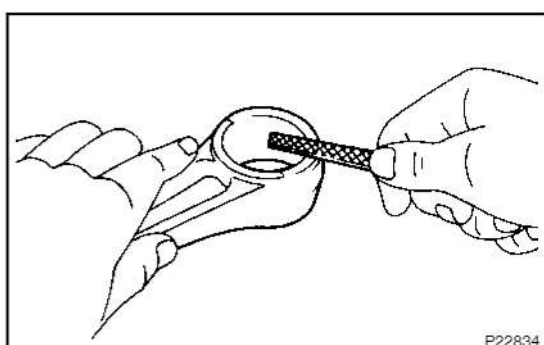

- (2) Using a round file, lightly file off any roughness from the small end of the connecting rod.

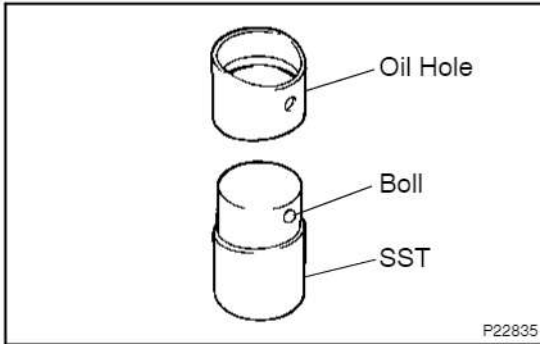

- (3) Attach the bushing to SST with the ball of SST inside the oil hole of the bushing.

SST 09222-17011 (09222-05031)

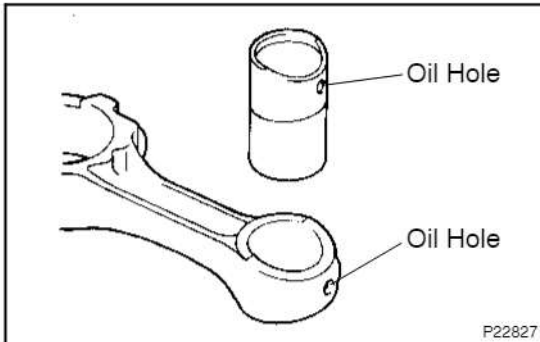

- (4) Align the oil holes of the new bushing and the connecting rod.

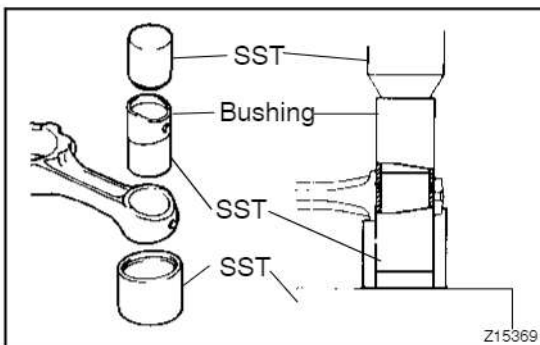

- (5) Using SST and a press, press in the bushing.

SST 09222-17011 (09222-05021, 09222-05031, 09222-05041)

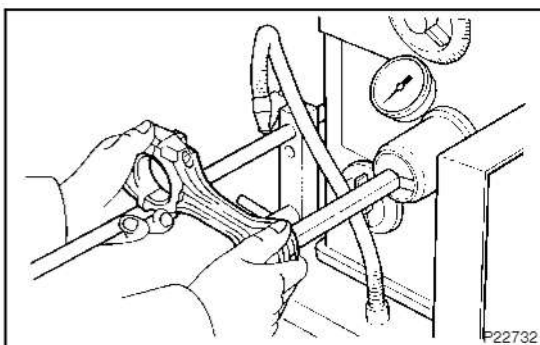

- (6) Using a pin hole grinder, hone the bushing to obtain the standard specified clearance (see item C above) between the bushing and piston pin.

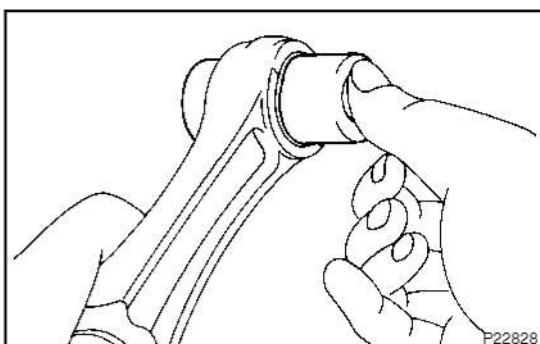

- (7) Check the piston pin fit at normal room temperature. Coat the piston pin with engine oil, and push it into the connecting rod engine oil, and push it into the connecting rod with your thumb.

11. CYLINDER BORING**HINT:**

- Bore all the 6 cylinders to the oversized piston outside diameter.
- Replace all the piston rings with ones to match the oversized pistons.

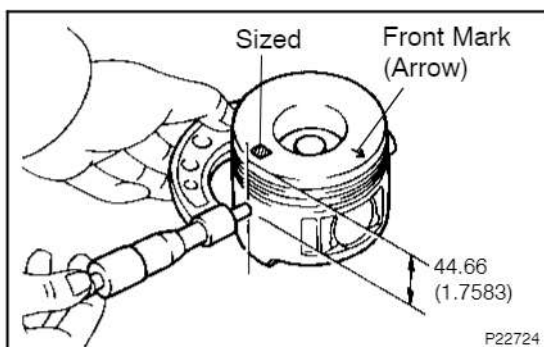
**12. KEEP OVERSIZED PISTONS****Oversized piston diameter:****O/S 0.50****94.370 – 94.400 mm (3.71535 – 3.71653 in.)****13. CALCULATE AMOUNT TO BORE CYLINDERS**

- Using a micrometer, measure the piston diameter at right angles to the piston pin center line.
- Calculate the amount each cylinder is to be rebored as follows:

Size to be rebored = P + C – H**P = Piston diameter****C = piston clearance****0.145 – 0.165 mm (0.0057 – 0.0065 in.)****H = Allowance for honing****0.02 mm (0.0008 in.) or less****14. BORE AND HONE CYLINDER TO CALCULATED DIMENSIONS****Maximum honing: 0.02 mm (0.0008 in.)****NOTICE:****Excess honing will destroy the finished roundness.****15. INSPECT CRANKSHAFT FOR RUNOUT**

- place the crankshaft on V- blocks.
- Using a dial indicator, measure the circle runout at the center journal.

Maximum circle runout: 0.06 mm (0.0024 in.)

If the circle runout is greater than maximum, replace the crankshaft.

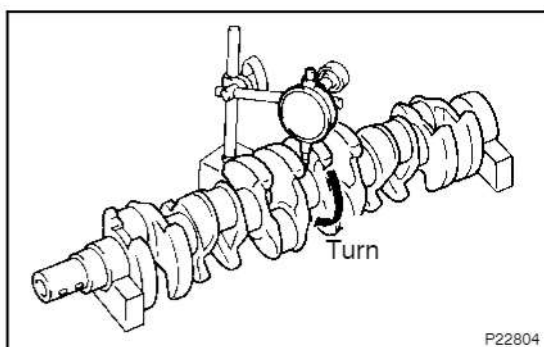

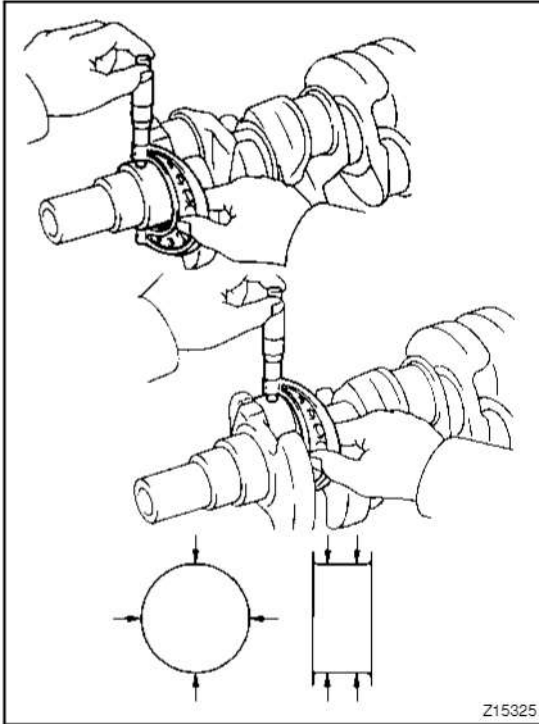

16. INSPECT MAIN JOURNALS AND CRANK PINS

- (a) Using a micrometer, measure the diameter of each main journal and crank pin.

Main journal diameter:

STD

66.982 – 67.000 mm (2.6371 – 2.6378 in.)

U/S 0.25

66.745 – 66.755 mm (2.6278 – 2.6281 in.)

U/S 0.50

66.495 – 66.505 mm (2.6179 – 2.6183 in.)

Crank pin diameter:

STD

58.982 – 59.000 mm (2.3221 – 2.3228 in.)

U/S 0.25

58.745 – 58.755 mm (2.3128 – 2.3132 in.)

U/S 0.50

58.495 – 58.505 mm (2.3029 – 2.3033 in.)

If the diameter is not as specified, check the oil clearance. (See Pub. No. RM617E, on page EM-121) If necessary, grind or replace the crankshaft.

- (b) Check each main journal and crank pin for taper and out-of-round as shown.

Maximum taper and out-of-round:

0.020 mm (0.0008 in.)

If the taper and out-of-round is greater than maximum, replace the crankshaft.

17. IF NECESSARY, GRIND AND HONE MAIN JOURNALS AND/OR CRANK PINS

Grind and hone the main journals and/or crank pins to the finished undersized diameter.

Install new main journal and/or crankshaft pin undersized bearing.

TROUBLESHOOTING

PROBLEM SYMPTOMS TABLE

TC025-03

HINT:

Before troubleshooting the turbocharger, first check the engine itself. (valve clearance, engine compression, injection timing etc.)

INSUFFICIENT ACCELERATION, LACK OF POWER OR EXCESSIVE FUEL CONSUMPTION

Possible Cause	Check Procedure and Correction Method	See page
1. Turbocharging pressure too low	Check turbocharging pressure.	TC-4
2. Restricted intake system	Check intake air system, and repair or replace parts as necessary.	EM-23 *1
3. Leak in intake air system	Check intake air system, and repair or replace parts as necessary.	EM-23 *1
4. Restricted exhaust system	Check exhaust system, and repair or replace parts as necessary.	EM-23 *1
5. Leak in exhaust system	Check exhaust system, and repair or replace parts as necessary.	EM-23 *1
6. Erratic turbocharger operation	Check exhaust system, and repair or replace parts as necessary.	EM-23 *1

ABNORMAL NOISE

Possible Cause	Check Procedure and Correction Method	See page
1. Turbocharging heat insulator resonance	Check for loose, improperly installed or deformed insulator nuts and bolt, and repair or replace as necessary.	TC-2
2. Exhaust pipe leaking or vibrating	Check for deformed exhaust pipe, loose bolts or damaged gasket, and repair or replace as necessary.	*1
3. Erratic turbocharger operation	Insufficient acceleration, lack of power or excessive fuel consumption.	TC-2

EXCESSIVE OIL CONSUMPTION OR WHITE EXHAUST

NOTICE:

Some oil mist in blowby from PCV is normal. Do not mistake it for oil leak from turbocharger.

Possible Cause	Check Procedure and Correction Method	See page
Faulty turbocharger oil seal	Check for oil leakage in exhaust system. <ul style="list-style-type: none"> Remove exhaust manifold converter or turbine elbow from turbocharger, and check for excessive carbon deposits on turbine wheel. Excessive carbon deposits indicate a faulty turbocharger. Check for oil leakage in intake air system. <ul style="list-style-type: none"> Check for axial and radial plays of turbine shaft, and replace turbocharger if necessary. 	TC-7

*1: 1HD-FTE ENGINE Repair Manual Pub. No. RM617E

TURBOCHARGER (European Spec.)

TC03R-01

PRECAUTION

MAINTENANCE PRECAUTION

- (a) Do not stop the engine immediately after pulling a trailer or after high speed or uphill driving. Idle the engine for 20 – 120 seconds, depending on how hard the vehicle has been driven.
- (b) Avoid sudden acceleration or racing immediately after starting a cold engine.
- (c) Do not run the engine with air cleaner removed, as this may cause foreign material to enter and damage the impeller wheel operating at high speed.
- (d) If the turbocharger is found to be defective and must be replaced, check for the cause, and repair or replace these items as necessary:
 - Engine oil level and quality
 - Conditions under which the turbocharger was used
 - Oil lines leading to the turbocharger
- (e) Use caution when removing and reinstalling the turbocharger assembly. Do not drop it or bang it against anything or grasp it by easily-deformed parts, such as the actuator or rod, when moving it.
- (f) Before removing the turbocharger, plug the intake and exhaust ports and oil inlet to prevent entry of dirt or other foreign material.
- (g) If replacing the turbocharger, check for accumulation of sludge particles in the oil pipes, and if necessary, replace the oil pipes.
- (h) Completely remove the gasket adhered to the lubrication oil pipe flange and turbocharger oil flange.
- (i) When replacing bolt or nuts, use only authorized replacement parts to prevent breakage or deformation.
- (j) If replacing the turbocharger, put 20 cm³ (1.2 cu in.) of oil into the turbocharger oil inlet and turn the impeller wheel by hand to spread oil to the bearing.
- (k) If overhauling or replacing the engine, cut the fuel supply after reassembly and crank the engine for 30 seconds to distribute oil throughout the engine. Then allow the engine to idle for 60 seconds.

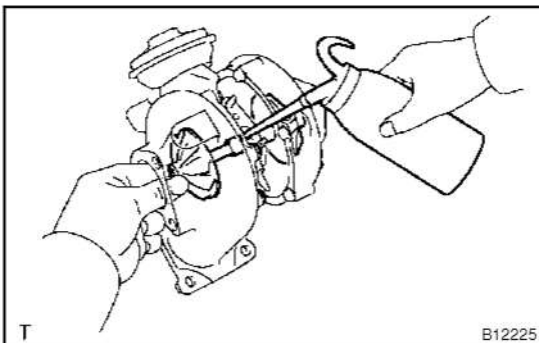
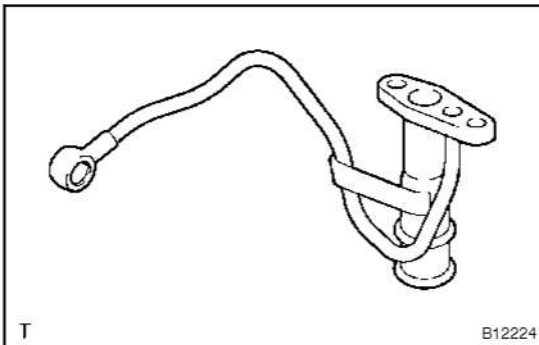

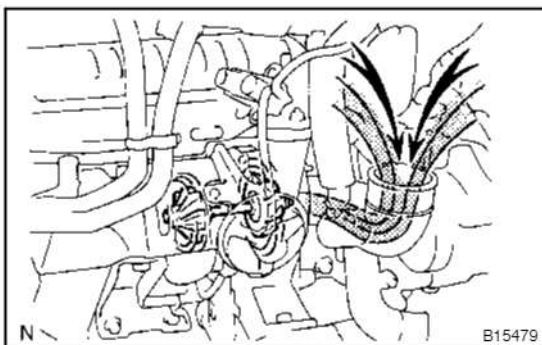

- (l) If the engine is running with out the air cleaner, case cover and hose, entry of foreign particles will damage the wheel which run at extremely high speed.



ON-VEHICLE INSPECTION

1. INSPECT INTAKE AIR SYSTEM

Check for leakage or clogging between the air cleaner housing and turbocharger inlet and between the turbocharger outlet and cylinder head.

- Clogged air cleaner Clean or replace element
- Hoses collapsed or deformed Repair or replace
- Leakage from connections Check each connection and repair
- Cracks in components Check and replace

2. INSPECT EXHAUST SYSTEM

Check for leakage or clogging between the cylinder head and turbocharger inlet and between the turbocharger outlet and exhaust pipe.

- Deformed components Repair or replace
- Foreign material in passages Remove
- Leakage from components Repair or replace
- Cracks in components Check and replace

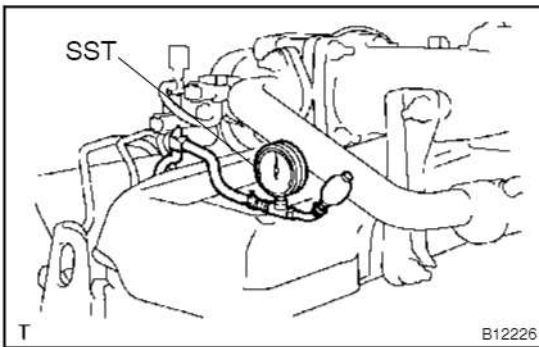

3. CHECK TURBOCHARGING PRESSURE

- (a) Warm up engine.
- (b) Using a 3 – way connector, connect SST (turbocharger pressure gauge) to the hose leading to the VSV for turbo pressure sensor..
SST 09992-00241
- (c) Press in the clutch pedal, then press the accelerator pedal down as far as it will go. Measure the turbocharging pressure at maximum speed 4300 rpm.

Standard pressure:

30.0 – 50.0 kPa (0.29 – 0.49 kgf/cm², 4.4 – 7.3 psi)

If the pressure is less than that specification, check the intake air and exhaust systems for leakage.

Then check the vacuum pipes for wrong installation, miss or damage.

Also check E-VRV etc.

If there is no leakage, replace the turbocharger assembly.

If the pressure is above specification, check if the actuator hose is disconnected or cracked. If not, replace the turbocharger assembly.

4. INSPECT IMPELLER WHEEL ROTATION

(See page TC-9)

5. INSPECT ACTUATOR OPERATION

(See page TC-9)

6. INSPECT TURBO PRESSURE SENSOR

(See page TC-13)

7. INSPECT E-VRV FOR TURBOCHARGING PRESSURE CONTROL (See page TC-15)

COMPONENTS

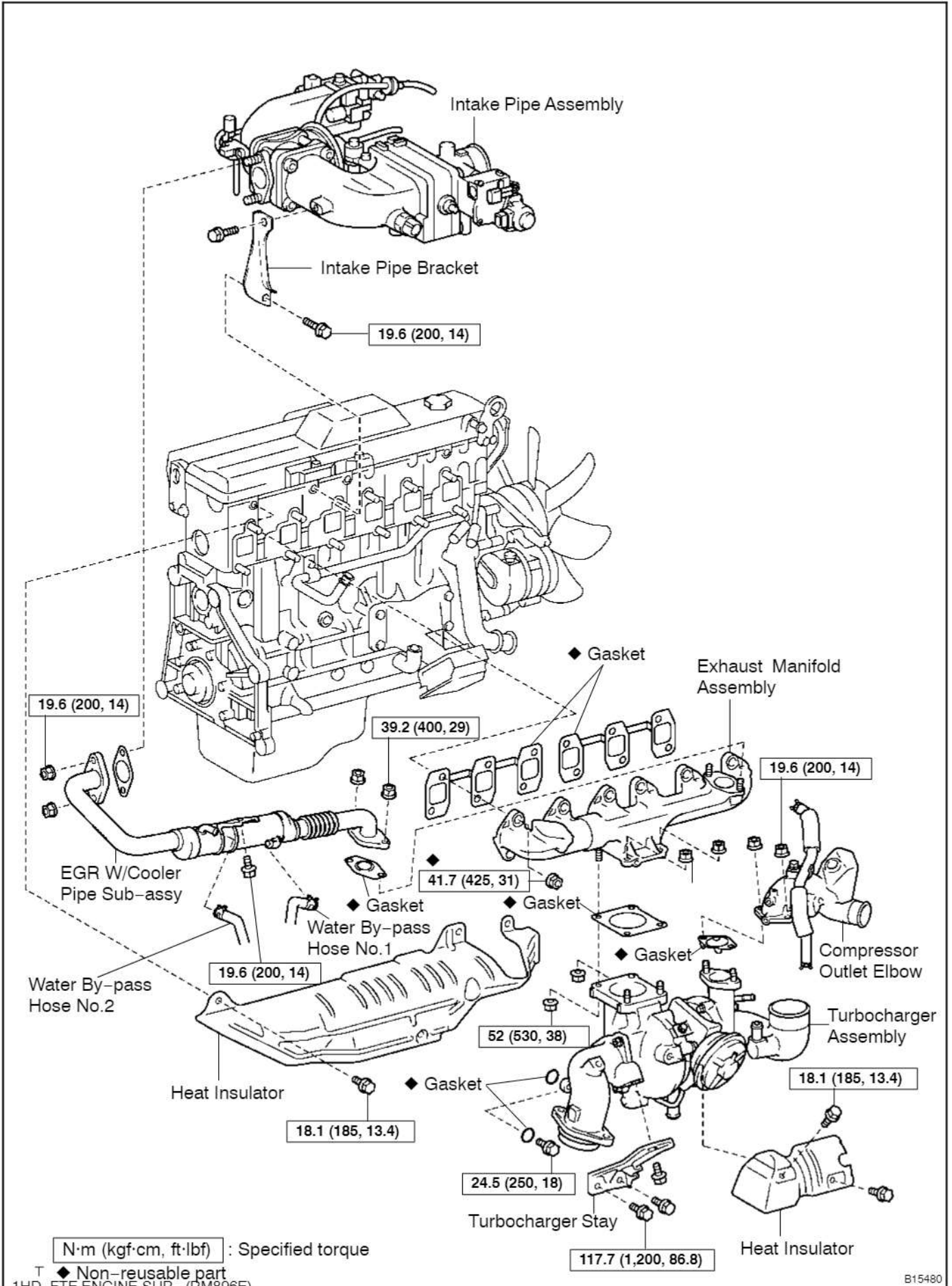

cardiagn.com

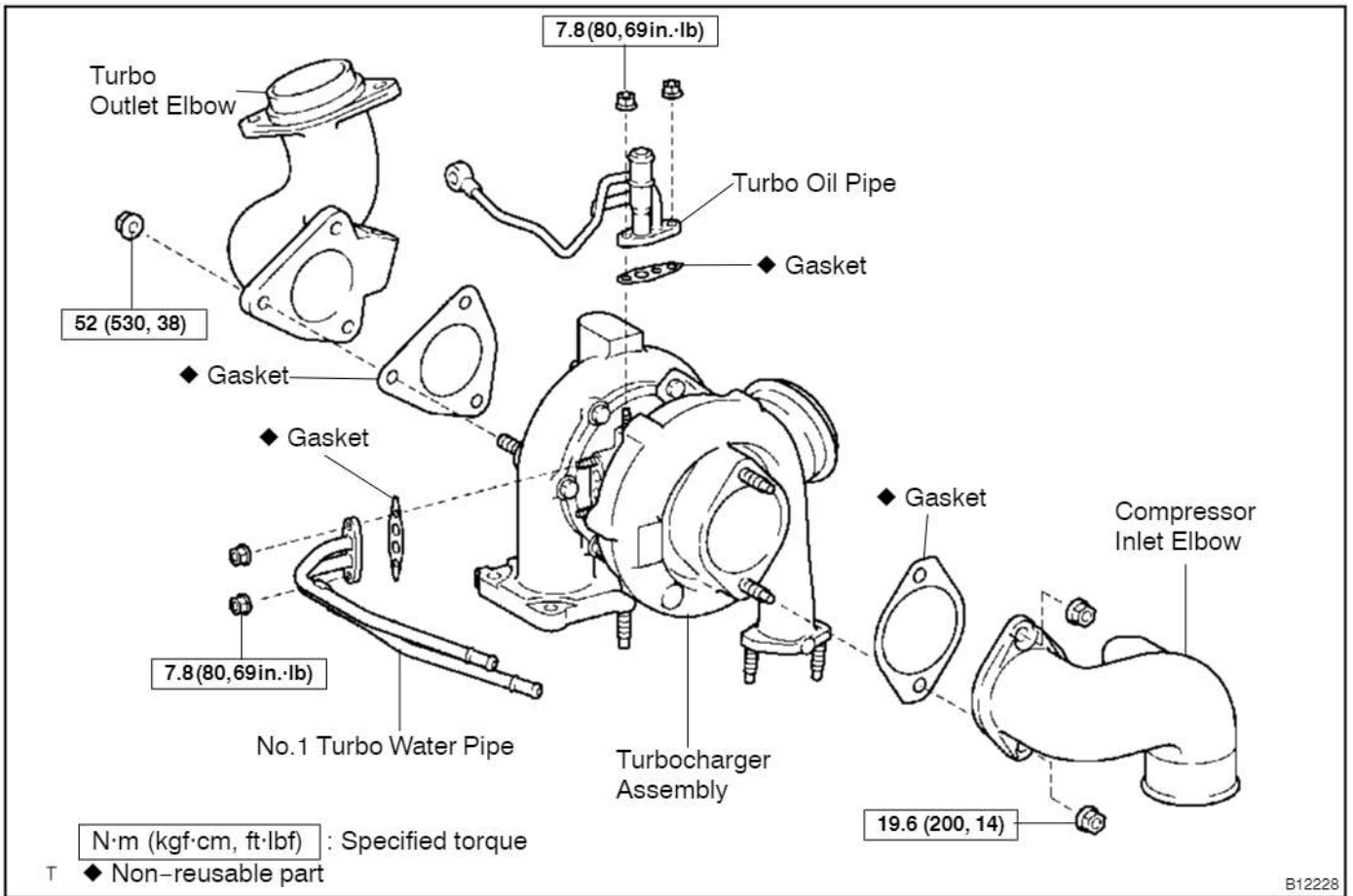

B12228

cardiagn.com

REMOVAL

1. DRAIN ENGINE COOLANT
2. REMOVE INTAKE PIPE ASSEMBLY
(See page EM-23)
3. REMOVE EGR W/COOLER PIPE SUB-ASSY
(See page EM-23)

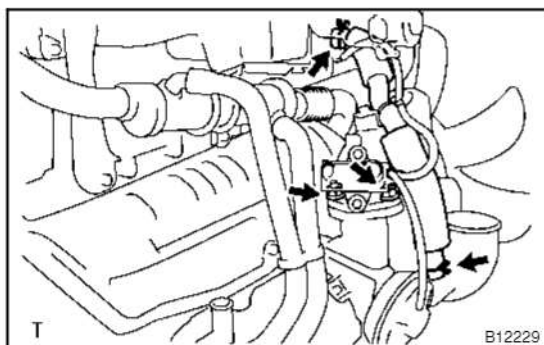

4. REMOVE PCV HOSE AND COMPRESSOR OUTLET ELBOW
 - (a) Disconnect the PCV hose.
 - (b) Remove the 2 nuts, compressor outlet elbow and gasket.
5. REMOVE HEAT INSULATOR (See page EM-23)

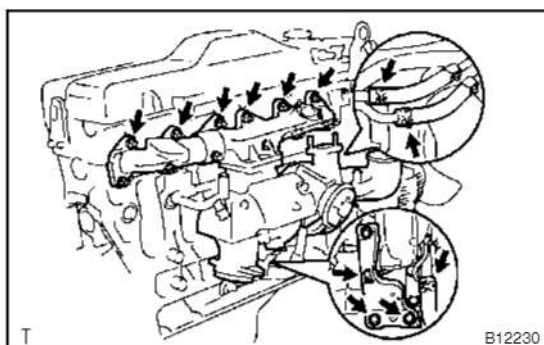

6. REMOVE TURBOCHARGER AND EXHAUST MANIFOLDS ASSEMBLY
 - (a) Remove the 3 bolts and turbocharger stay.
 - (b) Disconnect the turbo oil hose.
 - (c) Remove the union bolt and 2 gaskets holding the turbo oil pipe to the cylinder block.
 - (d) Disconnect the 2 water hose to the turbocharger.
 - (e) Remove the 12 nuts, exhaust manifold with turbocharger assembly and 2 gaskets.

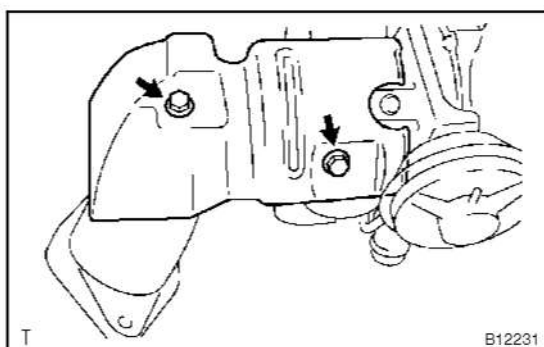

7. REMOVE HEAT INSULATOR
Remove the 2 bolts and heat insulator.

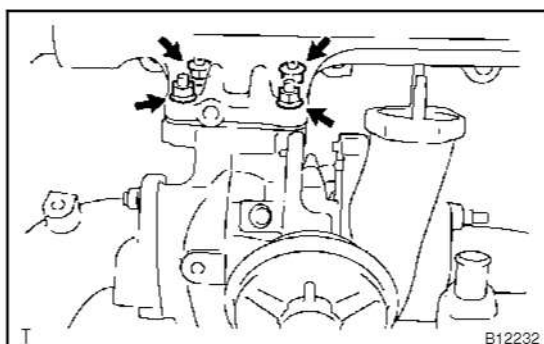

8. REMOVE TURBOCHARGER FROM EXHAUST MANIFOLDS
Remove the 4 nuts, turbocharger and gasket.

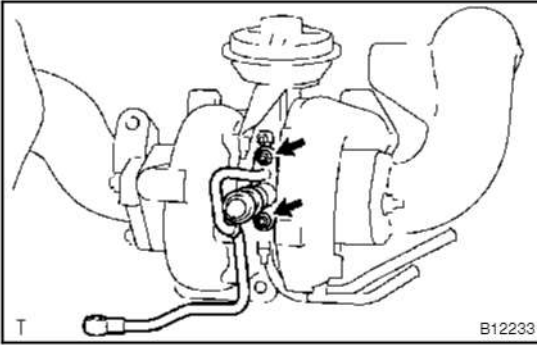
**9. REMOVE OIL PIPE**

Remove the 2 nuts, turbo oil pipe and gasket.

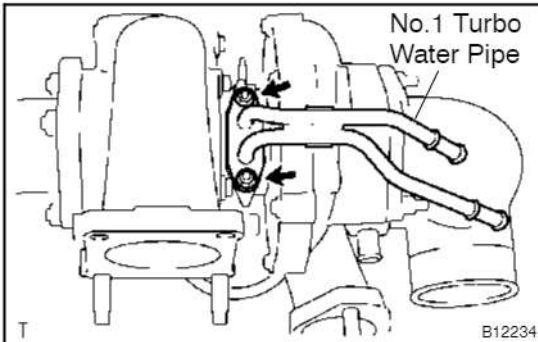
**10. REMOVE NO.1 TURBO WATER PIPE**

Remove the 2 nuts, No.1 turbo water pipe and gasket.

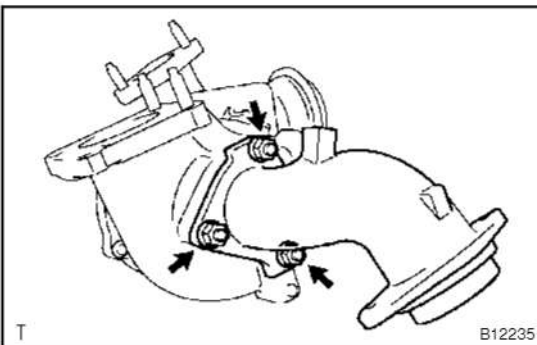
**11. REMOVE TURBO OUTLET ELBOW**

Remove the 3 nuts, turbo outlet elbow and gasket.

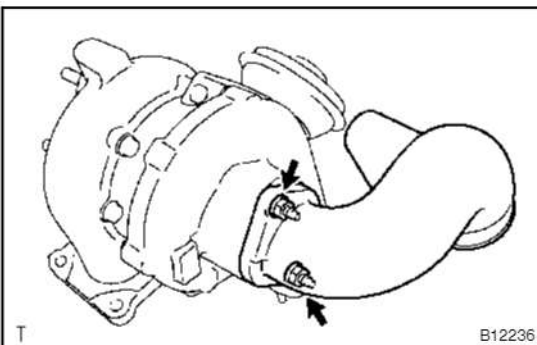
**12. REMOVE COMPRESSOR INLET ELBOW**

Remove the 2 nuts, compressor inlet elbow and gasket.

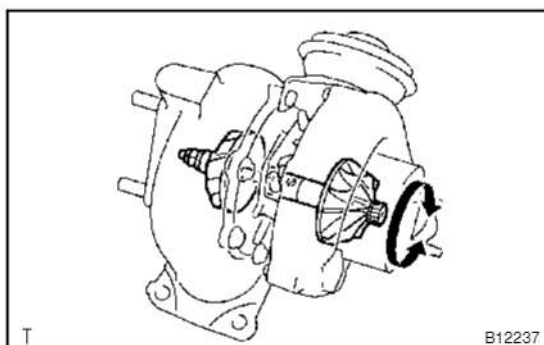

INSPECTION

1. INSPECT IMPELLER WHEEL ROTATION

Grasp the edge of the turbine wheel and turn it. Check that the impeller wheel turns smoothly.

If the impeller wheel does not turn or if it turns with a heavy drag, replace the turbocharger assembly.

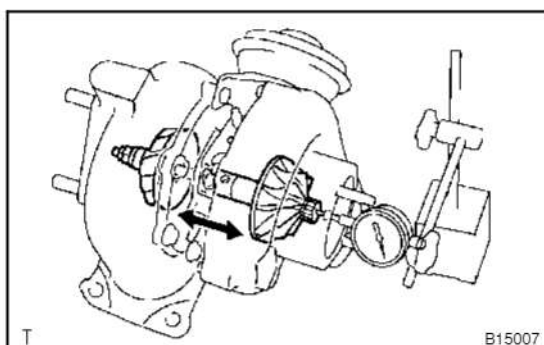

2. INSPECT AXIAL PLAY OF TURBINE SHAFT

Insert a dial indicator into the exhaust side hold the turbine wheel edge by hand, and check the axial play.

Maximum oil clearance: 0.083 mm (0.00327 in.) or less

If the axial play is not as specified, replace the turbocharger assembly.

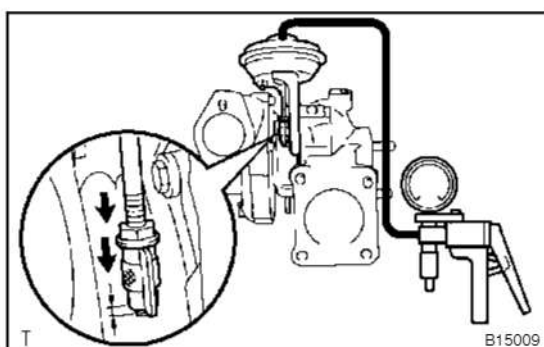

3. INSPECT ACTUATOR OPERATION

- (a) Apply vacuum (66 kPa, 500 mmHg, 20 in.Hg) and raise the actuator push rod.
- (b) Lower the vacuum and check the stroke when the vacuum is at the following values.

Standard stroke:

50.7 kPa (375 mmHg, 15 in.Hg): 0.2 mm (0.008 in.)

26.6 kPa (200 mmHg, 8 in.Hg): 5.0 mm (0.197 in.)

If operation is not as specified, replace the turbocharger.

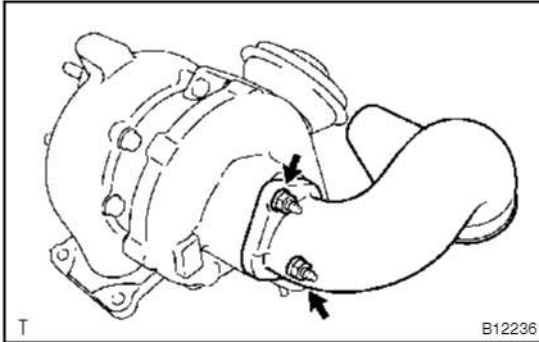

INSTALLATION

1. INSTALL COMPRESSOR INLET ELBOW

Install a new gasket and compressor inlet elbow with the 2 new nuts.

Torque: 19.6 N·m (200 kgf·cm, 14 ft·lbf)

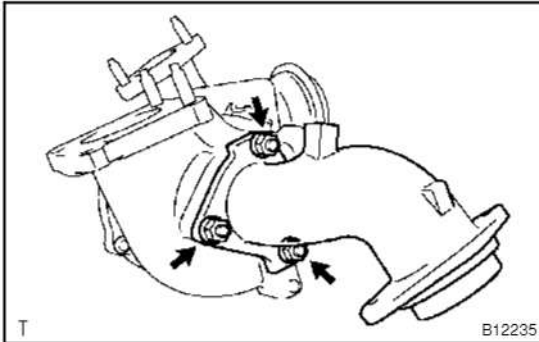

2. INSTALL TURBO OUTLET ELBOW

Install a new gasket and turbo outlet with the 3 nuts.

Torque: 52 N·m (530 kgf·cm, 38 ft·lbf)

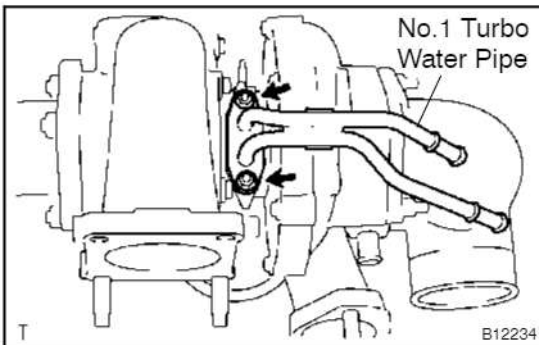

3. REMOVE NO.1 TURBO WATER PIPE

Install a new gasket and No.1 turbo water pipe with the 2 nuts.

Torque: 7.8 N·m (80 kgf·cm, 69 in·lbf)

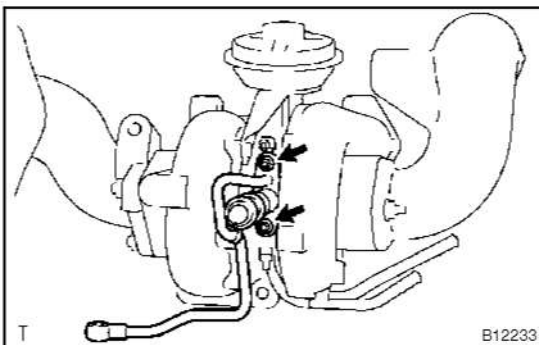

4. INSTALL OIL PIPE

Install a new gasket and turbo oil pipe with the 2 nuts.

Torque: 7.8 N·m (80 kgf·cm, 69 in·lbf)

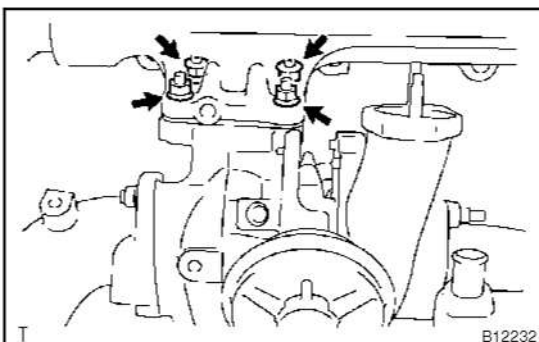

5. INSTALL TURBOCHARGER TO EXHAUST MANIFOLDS

Install a new gasket and turbocharger with the 4 nuts.

Torque: 52 N·m (530 kgf·cm, 38 ft·lbf)

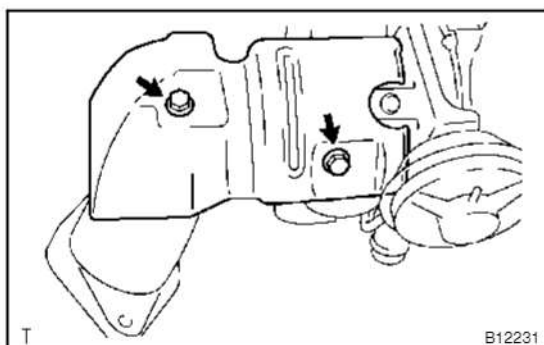
**6. INSTALL HEAT INSULATOR**

Install the heat insulator with the 2 bolts.

Torque: 18.1 N·m (185 kgf·cm, 13.4 ft·lbf)

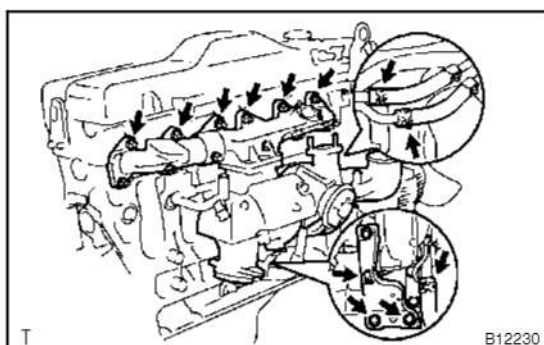
**7. INSTALL TURBOCHARGER AND EXHAUST MANIFOLDS ASSEMBLY**

(a) Install 2 new gaskets, turbocharger and exhaust manifolds assembly with the 12 nuts.

Torque: 41.7 N·m (425 kgf·cm, 31 ft·lbf)

(b) Connect the 2 water hoses from the turbocharger.

(c) Install 2 new gaskets and the union bolt of the turbo oil pipe.

Torque: 24.5 N·m (250 kgf·cm, 18 ft·lbf)

(d) Connect the turbo oil hose.

(e) Install the turbocharger stay with the 3 bolts.

Torque: 117.7 N·m (1200 kgf·cm, 86.8 ft·lbf)

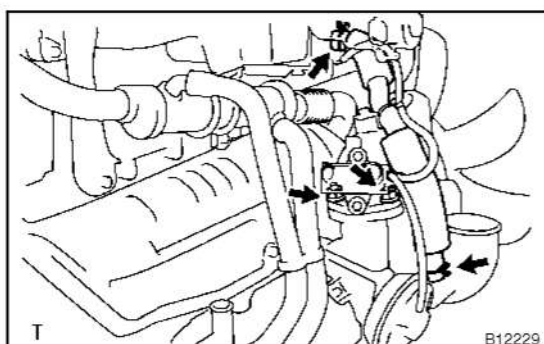
**8. INSTALL PCV HOSE AND COMPRESSOR OUTLET ELBOW**

(a) Install a new gasket and compressor outlet elbow with the 2 nuts.

Torque: 19.6 N·m (200 kgf·cm, 14.5 ft·lbf)

(b) Connect the PCV hose.

9. INSTALL HEAT INSULATOR (See page EM-36)

10. INSTALL EGR W/COOLER PIPE SUB-ASSY (See page EM-36)

11. INSTALL INTAKE PIPE ASSEMBLY (See page EM-36)

12. FILL WITH ENGINE COOLANT

13. START ENGINE AND CHECK FOR LEAK

14. CHECK ENGINE OIL LEVEL

INTERCOOLER COMPONENTS

TC03W-01

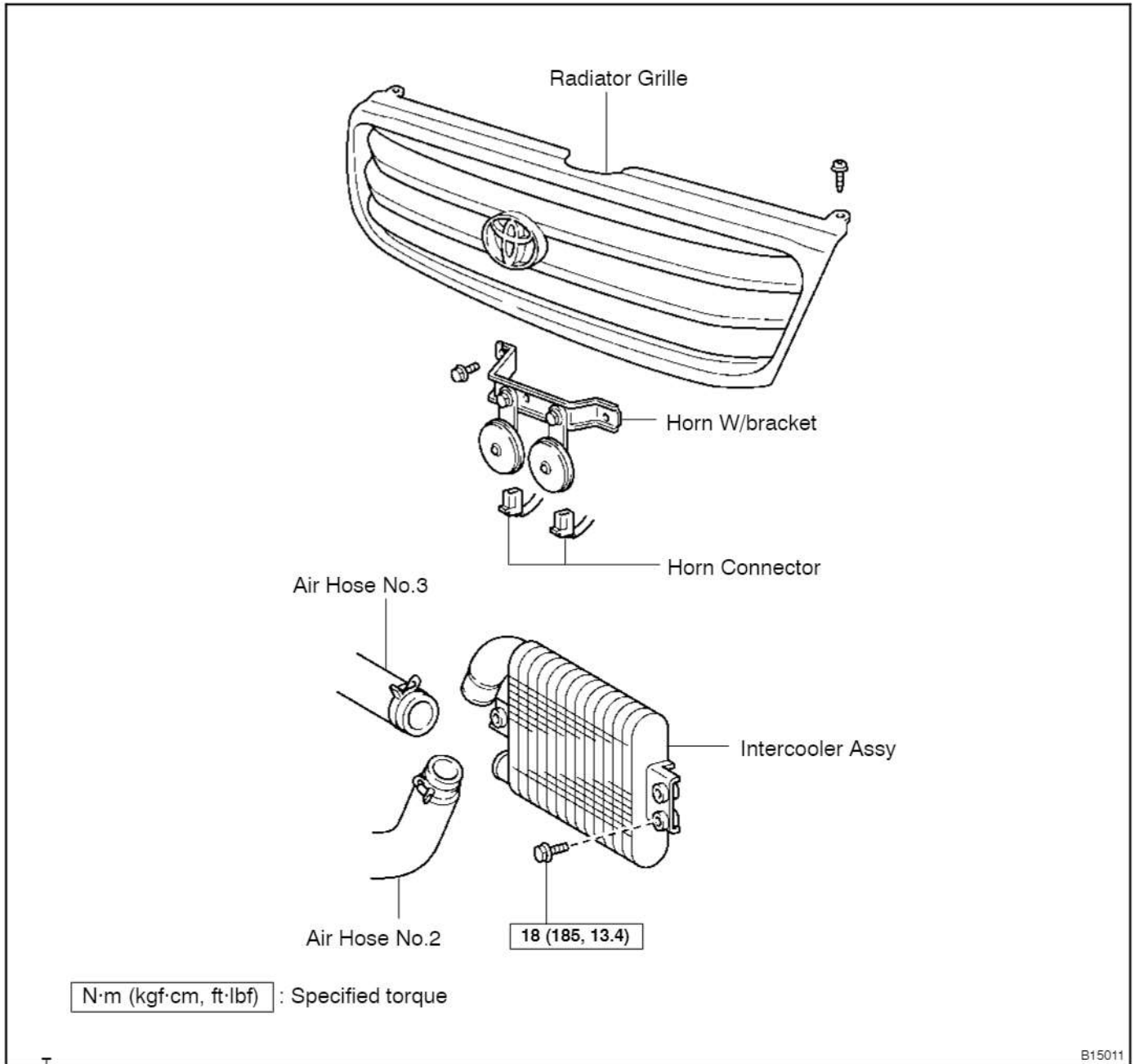

cardiagn.com

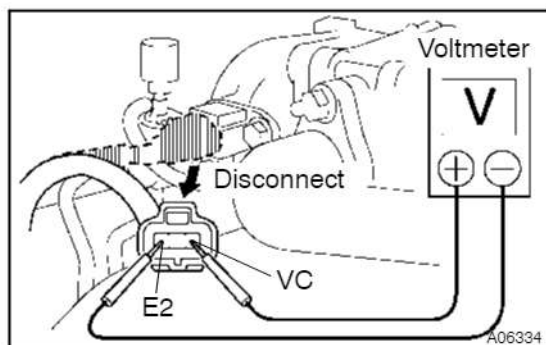

TURBO PRESSURE SENSOR INSPECTION

TC03X-01

1. **INSPECT POWER SOURCE VOLTAGE OF TURBO PRESSURE SENSOR**
 - (a) Disconnect the turbo pressure sensor connector.
 - (b) Turn the ignition switch ON.
 - (c) Using a voltmeter, measure the voltage between connector terminals VC and E2 of the wiring harness side.
Voltage:
4.75 - 5.25 V
 - (d) Turn the ignition switch OFF.
 - (e) Reconnect the turbo pressure sensor connector.

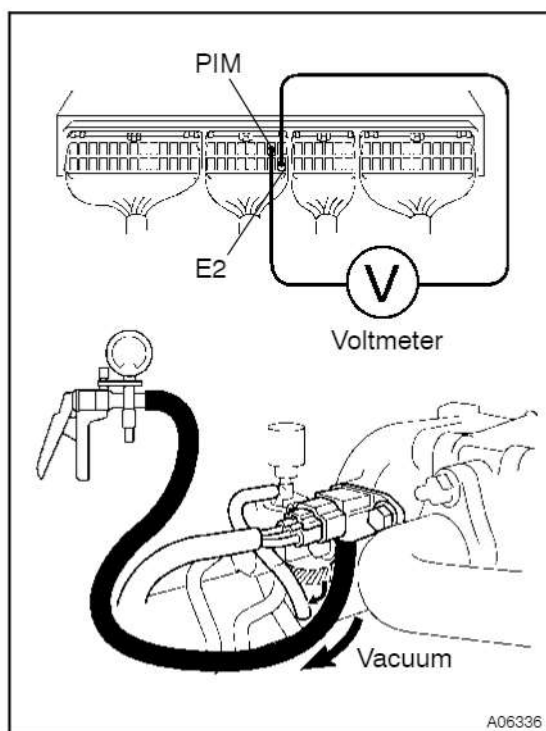

2. **INSPECT SUPPLY POWER OF TURBO PRESSURE SENSOR**
 - (a) Turn the ignition switch ON.
 - (b) Disconnect the vacuum hose from the turbo pressure sensor.
 - (c) Connect a voltmeter to terminals PIM and E2 of the ECU, and measure the output voltage under ambient atmospheric pressure.
 - (d) Apply vacuum to the turbo pressure sensor in 13.3 kPa (100 mmHg, 3.94 in.Hg) segments to 66.7 kPa (500 mmHg, 19.69 in.Hg).
 - (e) Measure the voltage drop from step (c) above for each segment.

Voltage drop:

Applied vacuum kPa (mmHg) (in.Hg)	13.3 (100) (3.94)	26.7 (200) (7.87)	40.0 (300) (11.81)
Voltage drop V	0.1 - 0.3	0.3 - 0.5	0.5 - 0.7

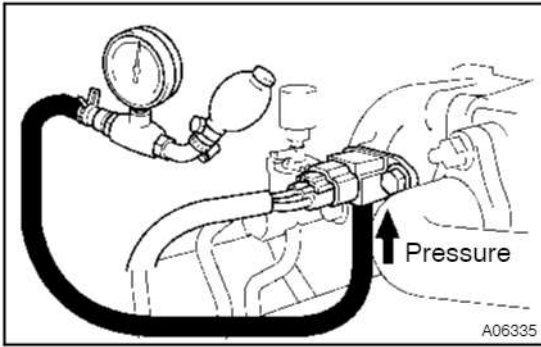

- (f) Using SST (turbocharger pressure gauge), apply pressure to the turbo pressure sensor in 9.8 kPa (0.10 kgf/cm², 1.4 psi) segments to 49.0 kPa (0.50 kgf/cm², 7.1 psi).

SST 09992-00241

- (g) Measure the voltage up from step (c) above for each segment.

Voltage up:

Applied pressure kPa (kgf/cm²) (psi)	19.6 (0.20) (2.84)	39.2 (0.40) (5.69)	58.8 (0.60) (8.53)	78.5 (0.80) (11.4)	98.0 (1.00) (14.2)
Voltage up V	0.15 - 0.45	0.4 - 0.7	0.7 - 1.0	1.0 - 1.3	1.3 - 1.6

- (h) Reconnect the vacuum hose to the turbo pressure sensor.

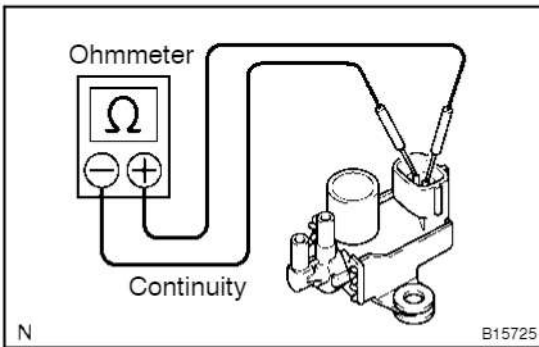

E-VRV FOR TURBOCHARGING PRESSURE CONTROL INSPECTION

TC03Y-01

1. INSPECT E-VRV FOR OPEN CIRCUIT

Using an ohmmeter, measure the resistance between terminals as shown.

Resistance: 11 - 13 Ω at 20 °C (68 °F)

If the resistance is not specified, replace the E-VRV.

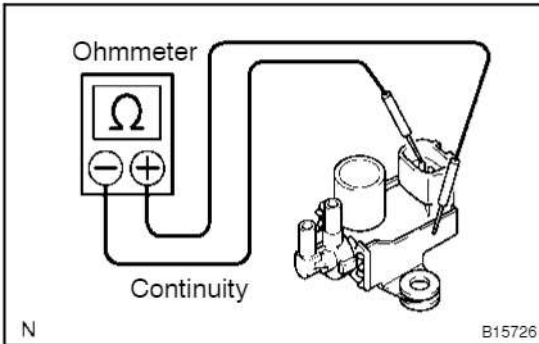

2. INSPECT E-VRV FOR GROUND

Using an ohmmeter, check that there is no continuity between terminals and E-VRV body.

If there is continuity, replace the E-VRV.

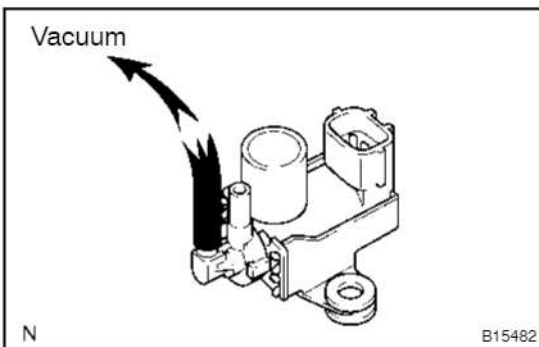

3. INSPECT E-VRV FOR AIR TIGHTNESS

Check that when vacuum is applied to the vacuum outlet port shown, the needle of vacuum pump indicates an increase of 86.7 kPa (650 mmHg, 25.6 in.Hg) or more.

If a problem is found, replace the E-VRV.

HINT:

Do not leave the connector disconnected over a long time with the engine running.

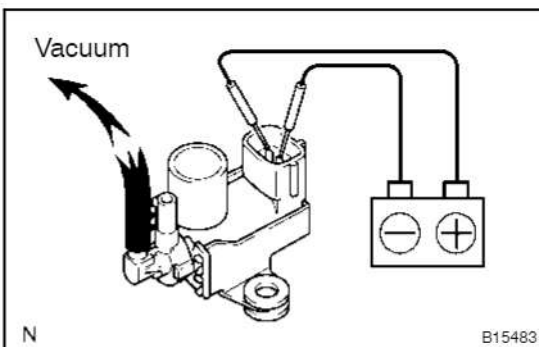

4. INSPECT E-VRV OPERATION

(a) Apply about 6 V of DC power to the terminals.

(b) Check that when vacuum is applied to the vacuum outlet port shown, the need does not move.

If operation is not as specified, replace the E-VRV.

EXHAUST GAS RECIRCULATION (EGR) SYSTEM (European Spec.)

COMPONENTS

EC09G-06

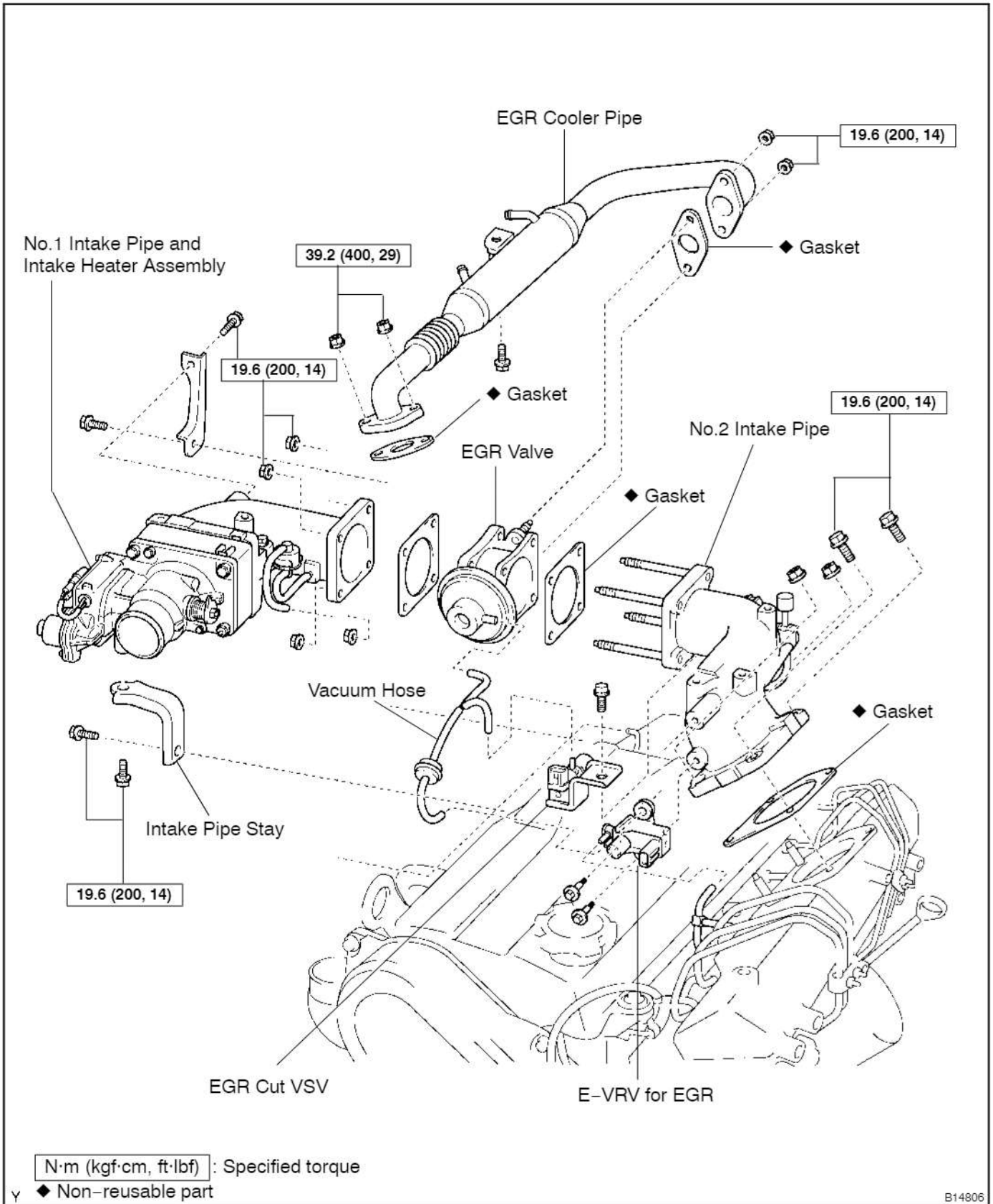

cardiagn.com

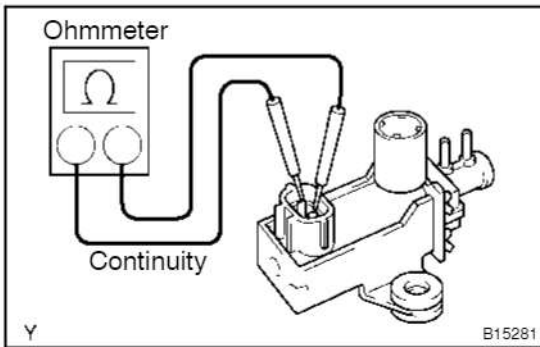

INSPECTION

1. INSPECT E-VRV FOR OPEN CIRCUIT

Using an ohmmeter, measure the resistance between terminals as shown.

Resistance: 11 – 13 Ω at 20 °C (68 °F)

If the resistance is not specified, replace the E-VRV.

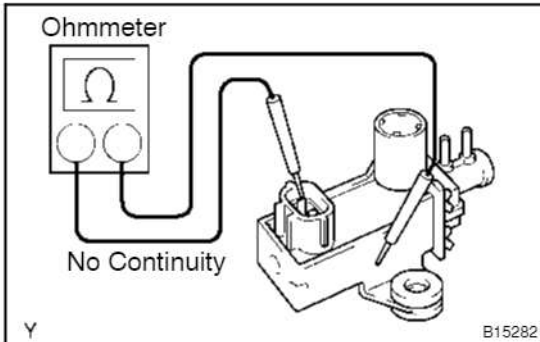

2. INSPECT E-VRV FOR GROUND

Using an ohmmeter, check that there is no continuity between terminals and E-VRV body.

If there is continuity, replace the E-VRV.

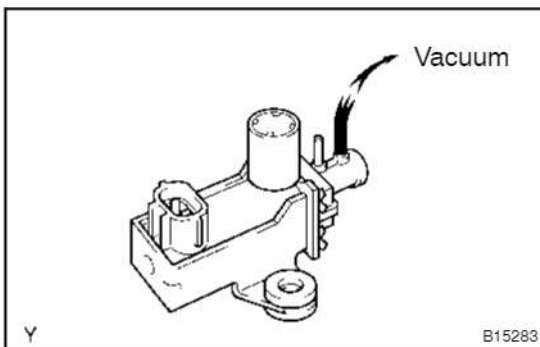

3. INSPECT E-VRV FOR AIR TIGHTNESS

Check that when vacuum is applied to the vacuum outlet port shown, the needle of vacuum pump indicates an increase of 86.7 kPa (650 mmHg, 25.6 in. Hg) or more.

If a problem is found, replace the E-VRV

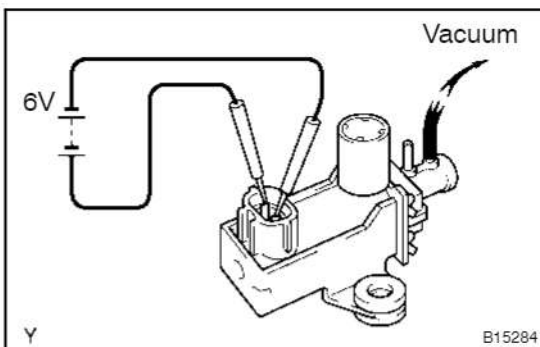

4. INSPECT E-VRV OPERATION

(a) Apply about 6 V of DC power to the terminals.

(b) Check that when vacuum is applied to the vacuum outlet port shown, the needle does not move.

If operation is not as specified, replace the E-VRV.

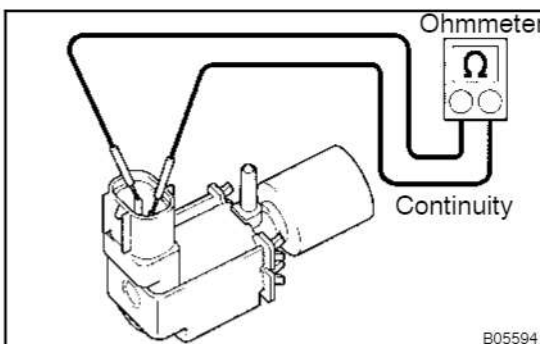

5. INSPECT VSV FOR OPEN CIRCUIT

Using an ohmmeter, check that there is continuity between terminals.

Resistance: 37 – 44 Ω at 20 °C (68 °F)

If there is no continuity, replace the VSV

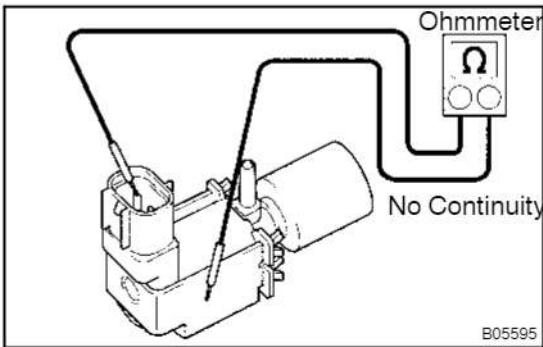

6. INSPECT VSV FOR GROUND

Using an ohmmeter, check that there is no continuity between terminals and body.
If there is continuity, replace the VSV.

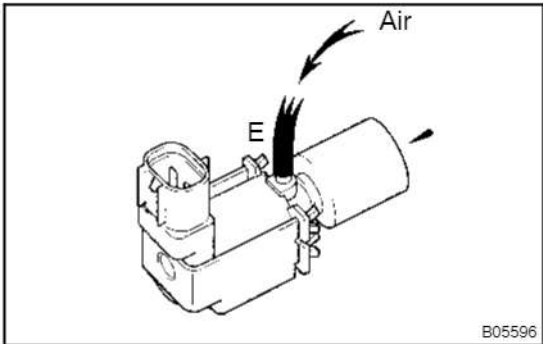

7. INSPECT VSV OPERATION

(a) Check that air does not flows from port E to the filter.

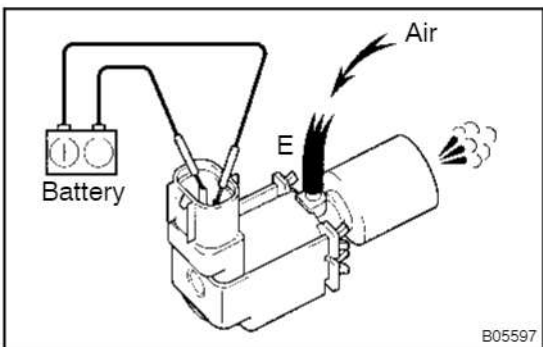

(b) Apply battery voltage across the terminals.

(c) Check that air flows from ports E to filter.

If operation is not as specified, replace the VSV.

8. INSPECT EGR VALVE

(a) Remove the EGR valve.

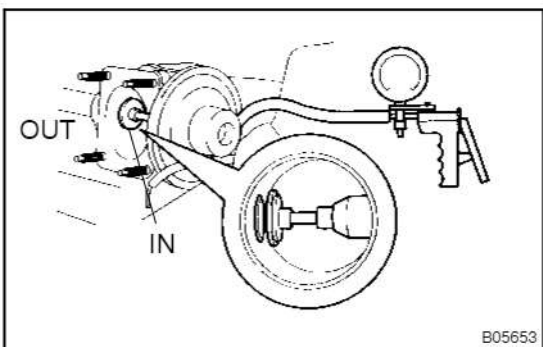

(b) Under the condition of applying the vacuum to the diaphragm chamber, check if there is ventilation between IN and OUT.

Standard:

Less than 13 kPa (100 mmHg, 3.8 in. Hg)

No ventilation

More than 27 kPa (200 mmHg, 8.0 in. Hg)

With ventilation

(c) When applying more than 67 kPa (500 mmHg, 19 in. Hg) of the vacuum, check if there is any leakage of the vacuum.

(d) Check the valve for sticking and heavy carbon deposits. If a problem is found, replace it.

(e) Reinstall the EGR valve with the new gasket.

9. INSPECT ACCELERATOR PEDAL POSITION SENSOR (See Pub. No. RM617E, on page DI-27, DI-34 and DI-39)

10. INSPECT ENGINE SPEED SENSOR (See Pub. No. RM617E, on page FU-113)

11. **INSPECT INTAKE AIR TEMPERATURE SENSOR**
(See Pub. No. RM617E, on page ED-7)
12. **INSPECT WATER TEMPERATURE SENSOR**
(See Pub. No. RM617E, on page ED-5)
13. **INSPECT TURBO PRESSURE SENSOR**
(See page TC-13)

THROTTLE BODY (European Spec.)

COMPONENTS

ED028-03

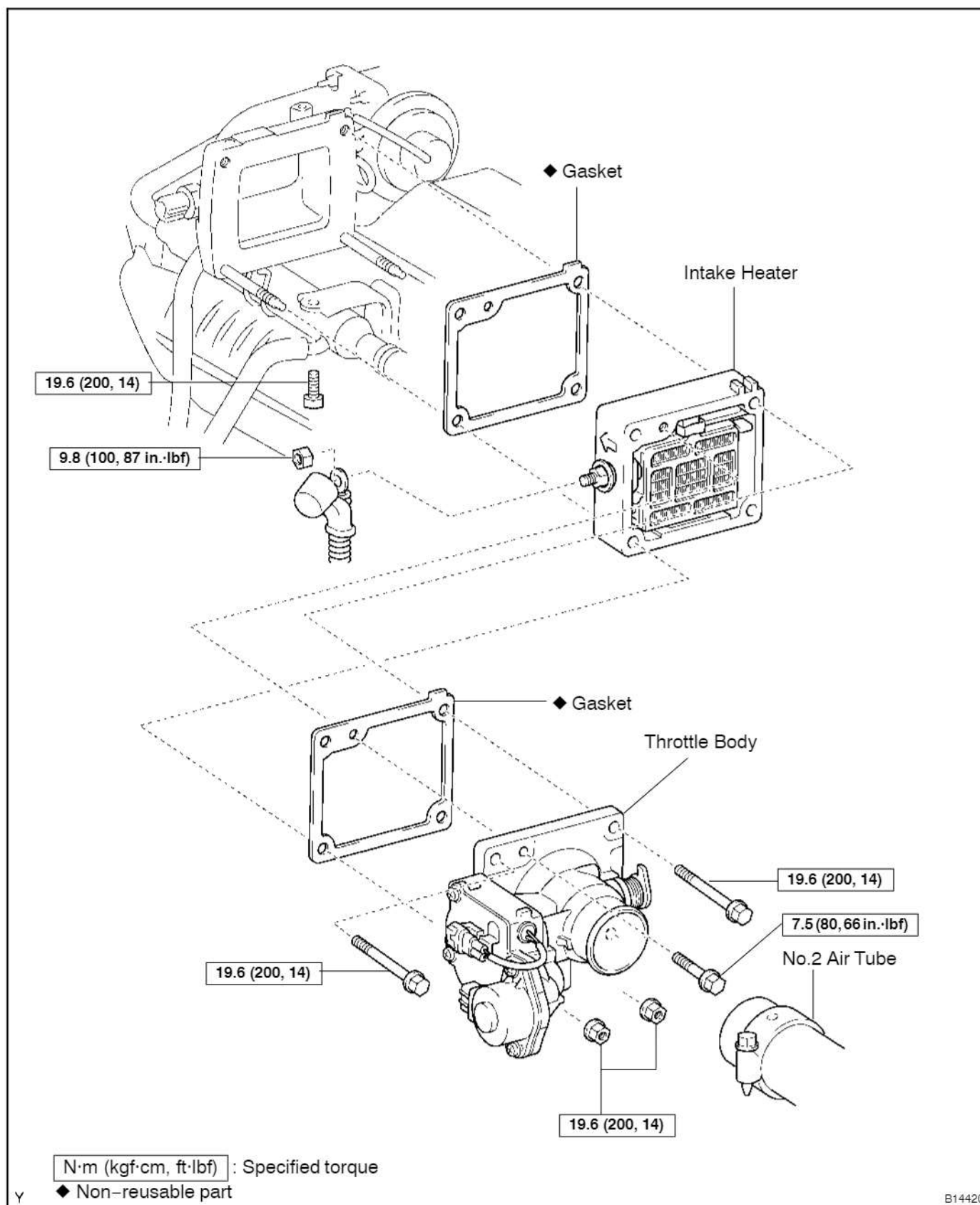

B14420

REMOVAL

1. DISCONNECT NO.2 AIR TUBE

2. REMOVE THROTTLE BODY

(a) Disconnect the throttle control motor connector and throttle full switch connector.

(b) Remove the 2 bolts and 2 nuts, throttle body and gasket.

Torque: 19.6 N·m (200 kgf·cm, 14 ft·lbf)

(c) Remove the bolts, intake heater and gasket.

Torque: 7.5 N·m (80 kgf·cm, 66 in·lbf)

INSPECTION

INSPECT THROTTLE BODY ([See page DI-23](#))

INSTALLATION

Installation is in the reverse order of removal. (See page ED-2)

INTAKE AIR CONTROL VALVE (European Spec.)

ED050-01

COMPONENTS

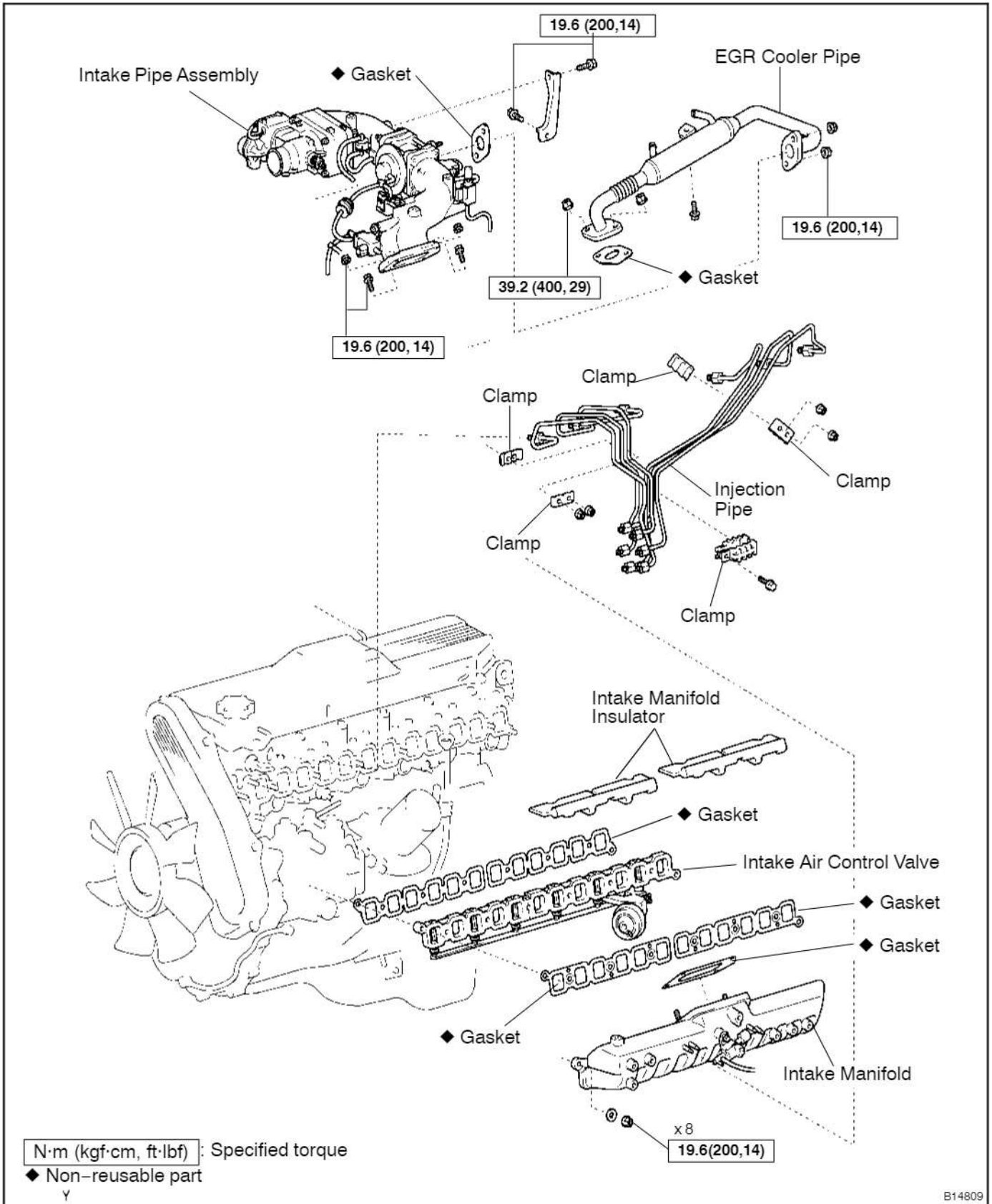

cardiagn.com

B14809

REMOVAL

REMOVE INTAKE MANIFOLD WITH INTAKE AIR CONTROL VALVE

(See page EM-23)

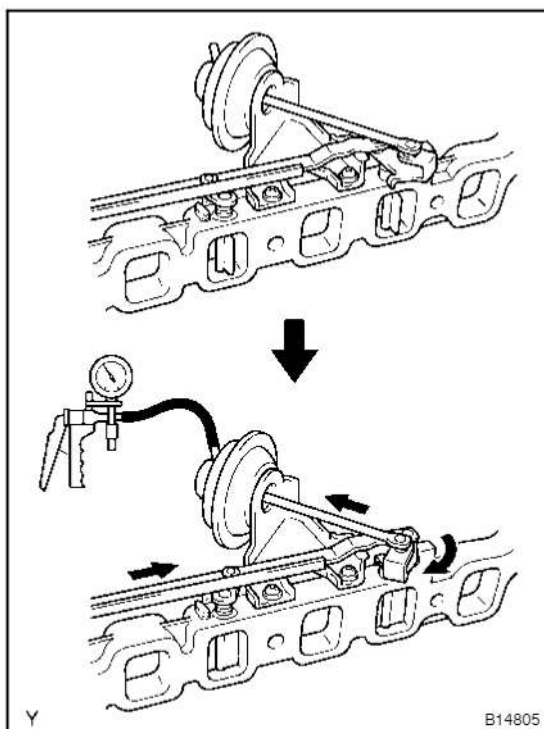

INSPECTION

INSPECT INTAKE AIR CONTROL VALVE

- (a) Apply vacuum (less than 60 kPa (450 mmHg, 18 in.Hg)) to the actuator, check that the actuator rod moves and close the valves.
- (b) One minute after applying the vacuum in (a), check that the actuator rod does not return.

If the operation is not as specified, replace the intake air control valve.

INSTALLATION

INSTALL INTAKE MANIFOLD WITH INTAKE AIR CONTROL VALVE

(See page EM-36)

VSV FOR INTAKE AIR CONTROL VALVE (European Spec.) COMPONENTS

ED055-01

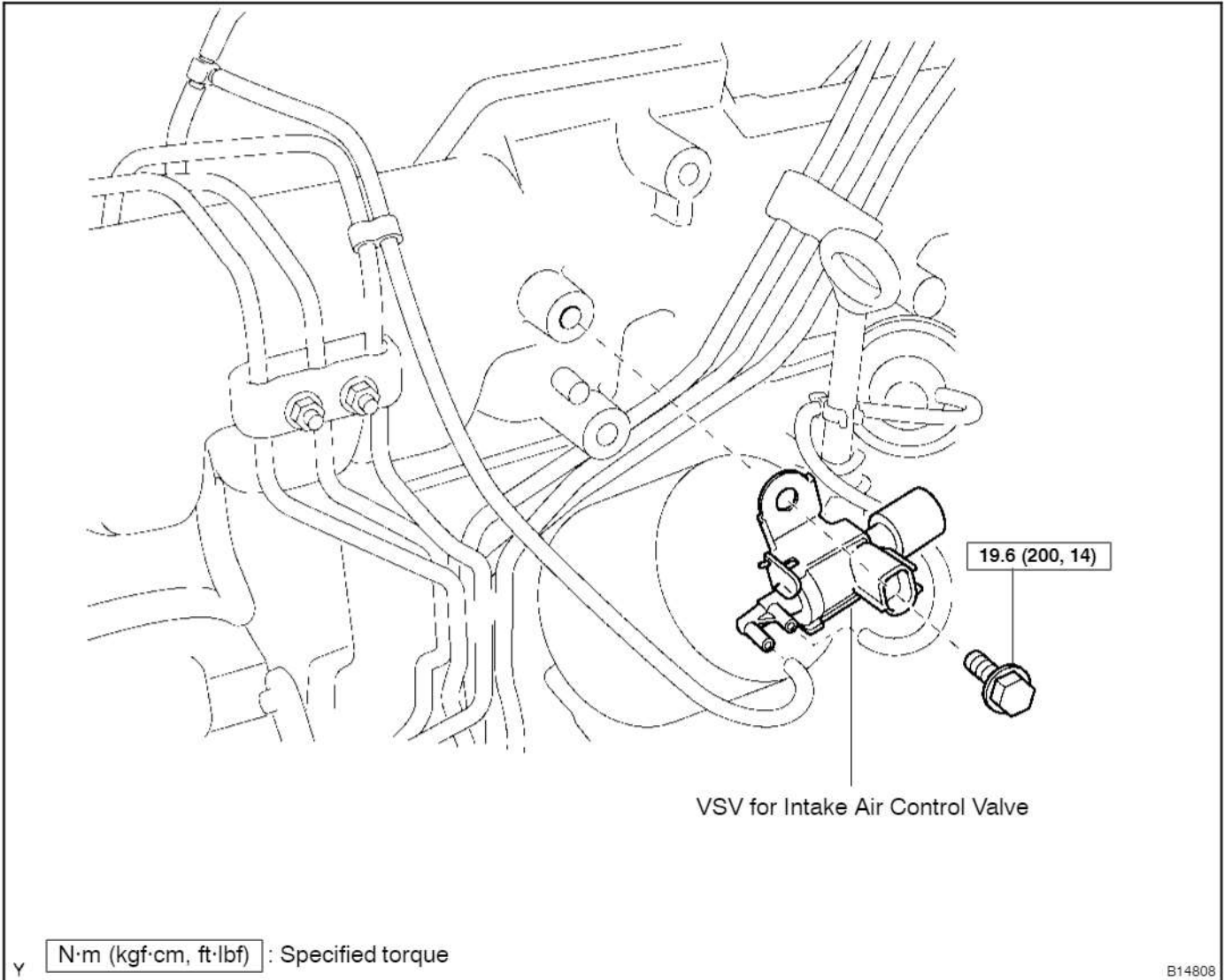

cardiagn.com

INSPECTION

1. REMOVE VSV

- (a) Disconnect the 2 vacuum hoses from the VSV.
- (b) Remove the bolt and VSV.

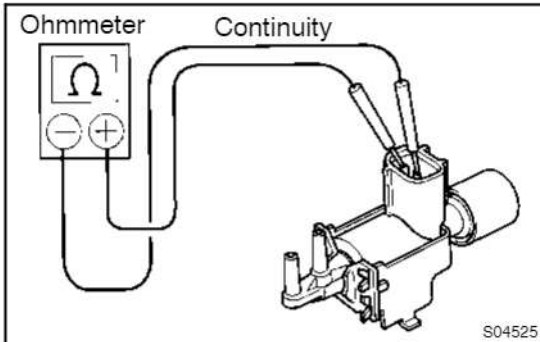

2. INSPECT VSV FOR OPEN CIRCUIT

Using an ohmmeter, check that there is continuity between each terminals.

Resistance: 33 – 39 Ω at 20°C (68°F)

If there is no continuity, replace the VSV.

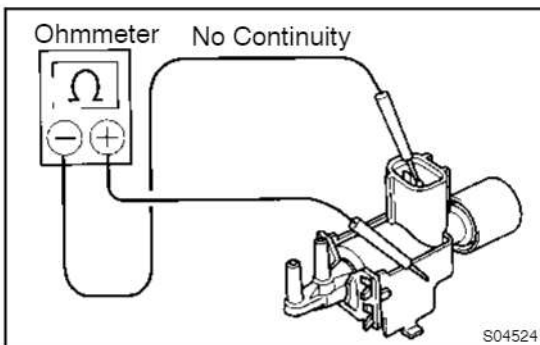

3. INSPECT VSV FOR GROUND

Using an ohmmeter, check that there is no continuity between each terminal and the body.

If there is continuity, replace the VSV.

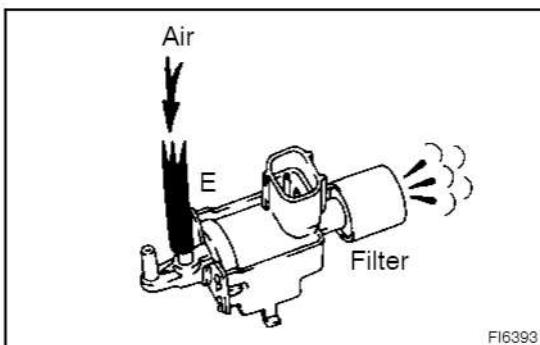

4. INSPECT VSV OPERATION

- (a) Check that air flows from port E to the filter.

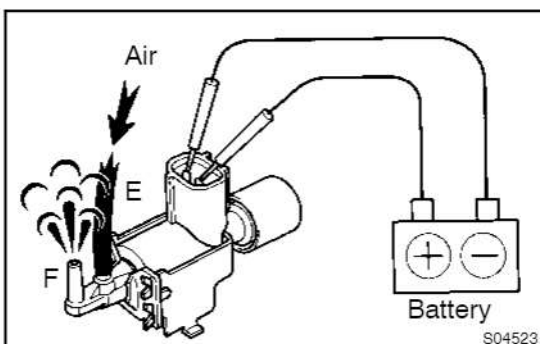

- (b) Apply battery voltage across the terminals.

- (c) Check that air flows from port E to port F.
- If operation is not as specified, replace the VSV.

5. REINSTALL VSV

- (a) Install the VSV with the bolt.
- (b) Connect the 2 vacuum to the VSV.

ENGINE ECU (European Spec.) INSPECTION

ED028-02

HINT:

The ECD circuit can be checked by measuring the resistance and voltage at the wiring connectors of the engine ECU.

1. REMOVE ENGINE ECU FROM VEHICLE BODY
2. INSPECT VOLTAGE OF ENGINE ECU
(See page DI-18)
3. INSPECT RESISTANCE OF ECD CIRCUITRY

Terminals	Condition	STD resistance (Ω)
LU+A \leftrightarrow +B	-	15 - 30
LU-A \leftrightarrow +B	-	15 - 30
LU+B \leftrightarrow +B	-	15 - 30
LU-B \leftrightarrow +B	-	15 - 30
THA \leftrightarrow E2	Intake air temp. 20°C (68°F)	2.0 - 3.0 k
THF \leftrightarrow E2	Fuel temp. 20°C (68°F)	2.0 - 3.0 k
THW \leftrightarrow E2	Coolant temp. 80°C (176°F)	0.2 - 0.4 k
TDC+ \leftrightarrow TDC-	Cold (-10°C (14°F) to 50°C (122°F))	19 - 32
TDC+ \leftrightarrow TDC-	Hot (50°C (122°F) to 100°C (212°F))	24 - 37
NE+ \leftrightarrow NE-	-	205 - 255
TCV \leftrightarrow +B	-	10 - 16
EGR \leftrightarrow +B	-	11 - 18
EGRC \leftrightarrow +B	25°C (77°F)	30 - 40
PA \leftrightarrow +B	25°C (77°F)	30 - 40
SVR \leftrightarrow +B	-	60 - 80
IREL \leftrightarrow E01	-	4 - 8
MREL \leftrightarrow E01	-	60 - 80
SCV \leftrightarrow +B	-	30 - 40

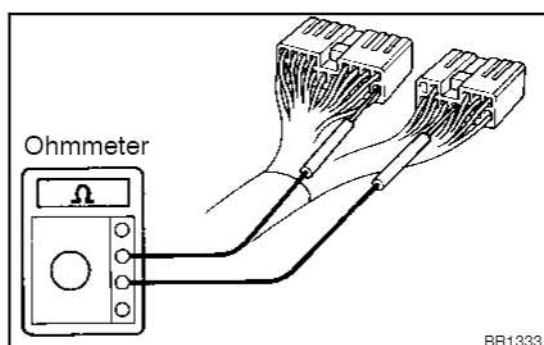

BR1333

- (a) Turn the ignition switch OFF.
- (b) Disconnect the 4 connectors from the engine ECU.
- (c) Measure the resistance between each terminal of the wiring connectors.

NOTICE:

- Do not touch the engine ECU terminals.
- The tester probe should be inserted in the wiring connector from the wiring side

INJECTION NOZZLE COMPONENTS

FUGAD-01

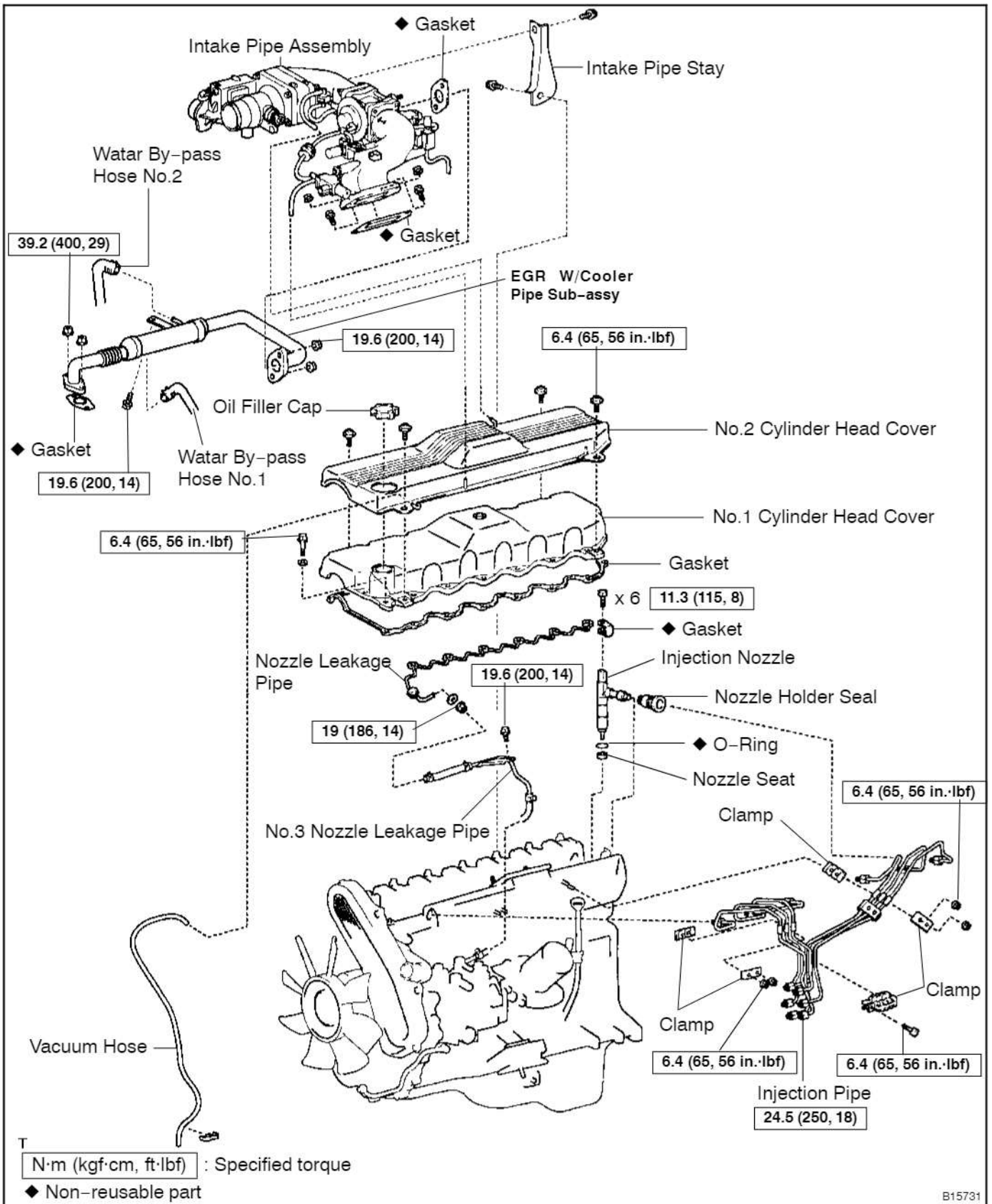

cardiagn.com

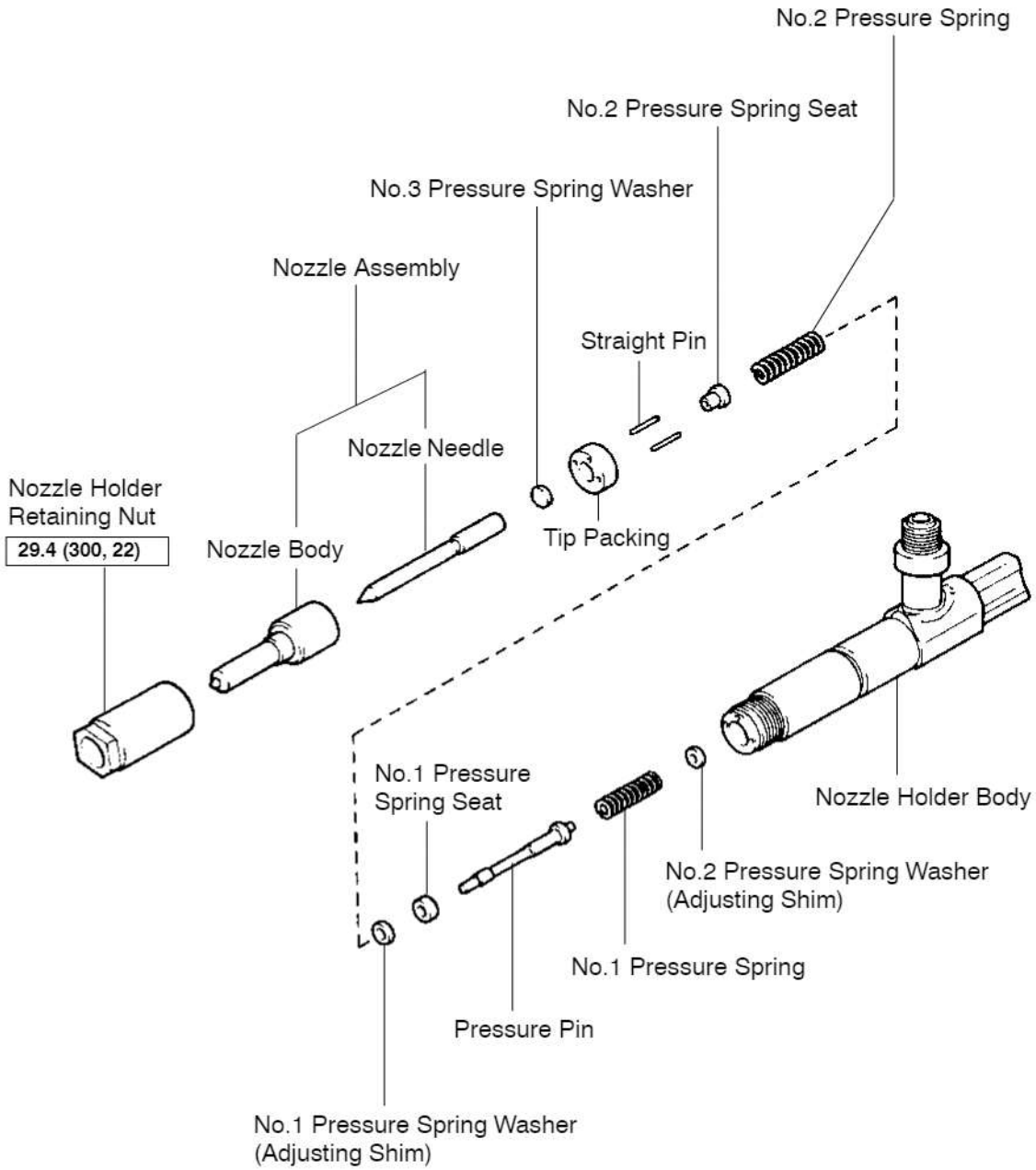

N·m (kgf·cm, ft·lbf) : Specified torque

B05384

REMOVAL

1. REMOVE INTAKE PIPE (See page EM-23)
2. REMOVE EGR W/COOLER PIPE SUB-ASSY (See page EM-23)
3. REMOVE NO.1 AND NO.2 CYLINDER HEAD COVERS (See page EM-23)

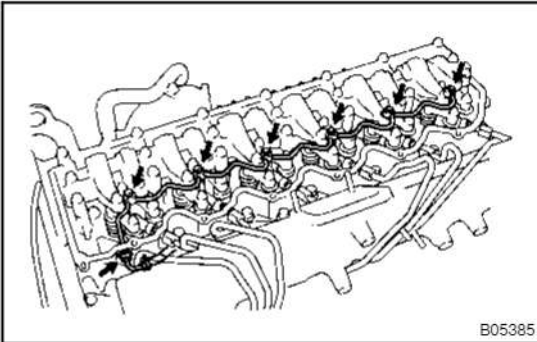

4. REMOVE NO.1 NOZZLE LEAKAGE PIPE

- (a) Disconnect the fuel return hose from the No.1 nozzle leakage pipe.
- (b) Remove the nut holding the No.1 nozzle leakage pipe to the cylinder head.
- (c) Remove the 6 hollow bolts, 7 gaskets and No.1 nozzle leakage pipe.

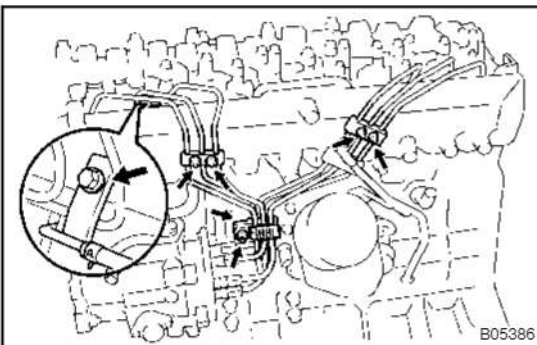

5. REMOVE INJECTION PIPES

- (a) Remove the bolt holding the No.3 nozzle leakage pipe to the intake manifold.
- (b) Remove the 4 nuts and 2 clamps from the intake manifold.
- (c) Remove the bolt, nut and clamp.

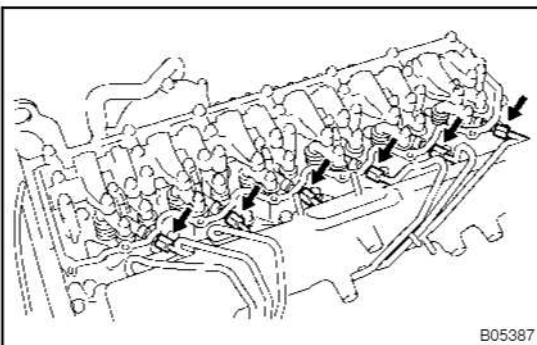

- (d) Loosen the 6 union nuts of the injection pipes from the injection nozzles.

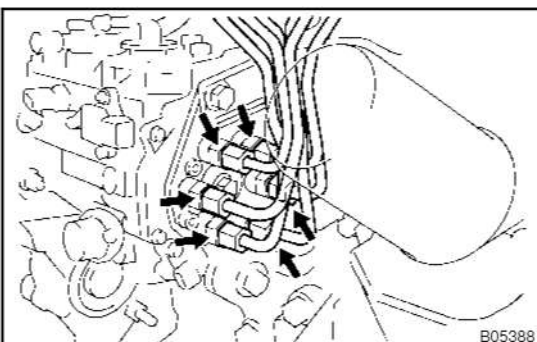

- (e) Loosen the 6 union nuts of the injection pipes from the injection pump.
- (f) Remove the 6 injection pipes.
- (g) Remove the 2 clamps.

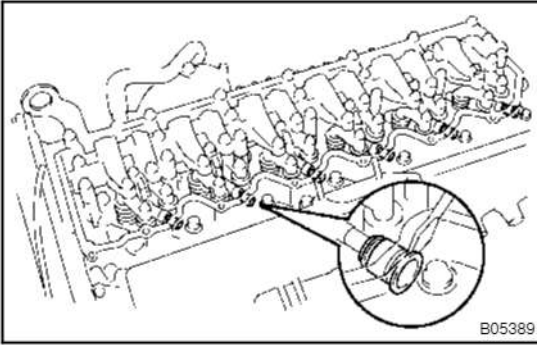

6. REMOVE NOZZLE HOLDER SEALS

Using a screwdriver, pry out the nozzle holder seals from the cylinder head.

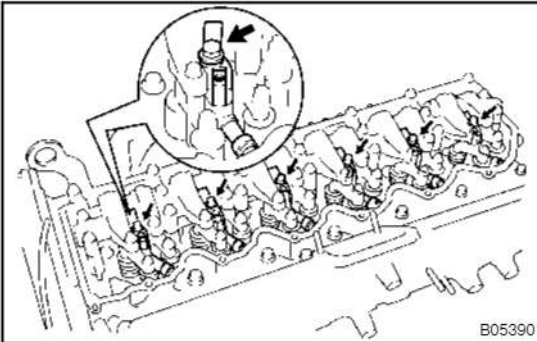

7. REMOVE INJECTION NOZZLES

- (a) Remove the bolt and washer holding the nozzle holder clamp to the cylinder head.
- (b) Remove the 6 injection nozzles and seats from the cylinder head.
- (c) Remove the O-ring from the injection nozzle.

HINT:

Arrange the injection nozzles in correct order.

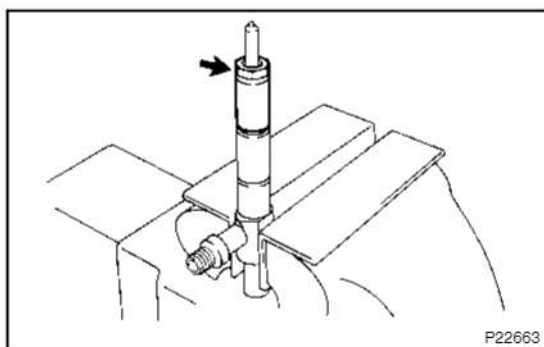

DISASSEMBLY

DISASSEMBLE INJECTION NOZZLES

(a) Remove the nozzle holder retaining nut.

NOTICE:

When disassembling the nozzle, careful not to drop the inner parts.

(b) Disassemble the injection nozzle.

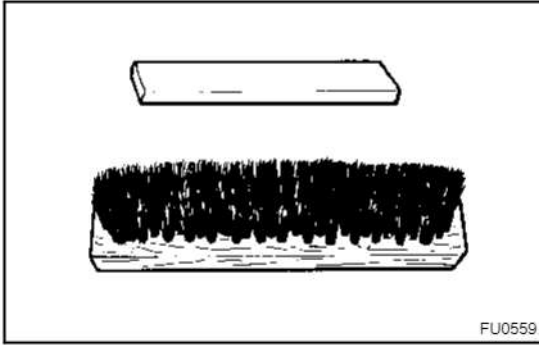

INSPECTION

1. NOZZLE CLEANING

- (a) To wash the nozzles, use a wooden stick and brass brush. Wash them in clean diesel fuel.

HINT:

Do not touch the nozzle mating surfaces with your fingers.

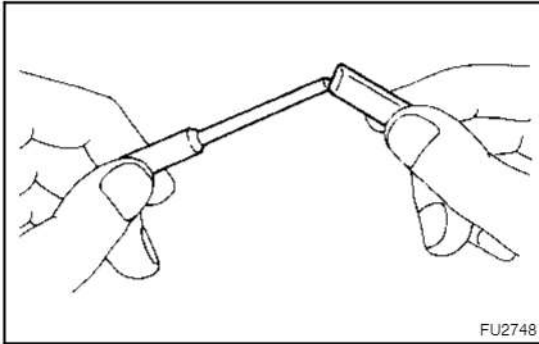

- (b) Using a wooden stick, remove the carbon adhering to the nozzle needle tip.

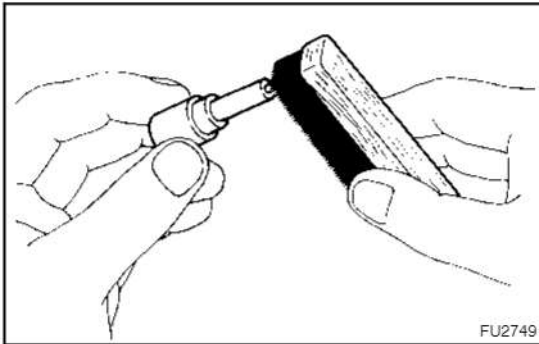

- (c) Using a brass brush, remove the carbon from the exterior of the nozzle body (except lapped surface).

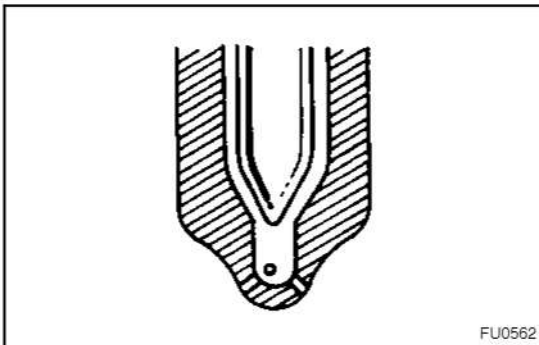

- (d) Check the seat of the nozzle body for burns or corrosion.
 (e) Check the nozzle needle tip for damage or corrosion. If any of these conditions are present, replace the nozzle assembly.

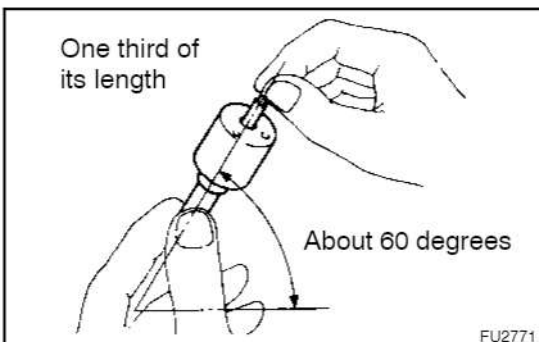

2. INSPECT NOZZLE ASSEMBLY

- (a) Wash the nozzle in clean diesel fuel.

HINT:

Do not touch the nozzle mating surfaces with your fingers.

- (b) Tilt the nozzle body about 60 degrees and pull the needle out about one third of its length.

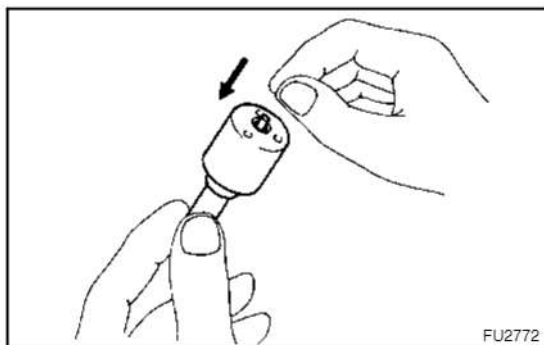

FU2772

- (c) When released, the needle should stick down into the body vent smoothly by its own weight.
- (d) Repeat this test, rotating the needle slightly each time. If the needle does not sink freely, replace the nozzle assembly.

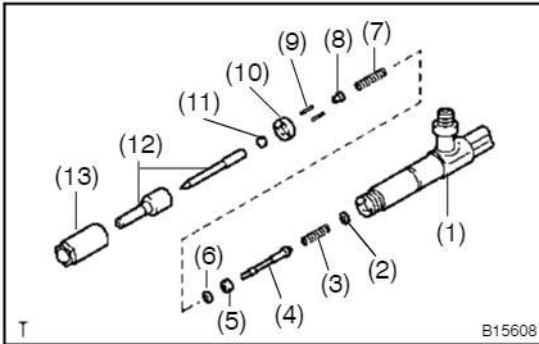

ADJUSTMENT

1. CHECK NO.2 OPENING PRESSURE

(a) Assemble these parts:

- (1) Nozzle holder body
- (2) No.2 pressure spring washer (Adjusting shim)
- (3) No.1 pressure spring
- (4) Pressure pin
- (5) No.1 pressure spring seat
- (6) No.1 pressure spring washer (Adjusting shim)
- (7) No.2 pressure spring
- (8) No.2 pressure spring seat
- (9) Straight pins
- (10) Tip packing
- (11) No.3 pressure spring washer
- (12) Nozzle assembly
- (13) Retaining nut

NOTICE:

Do not assemble the No.1 pressure spring, pressure pin and adjusting shim for adjustment of the No.1 opening pressure.

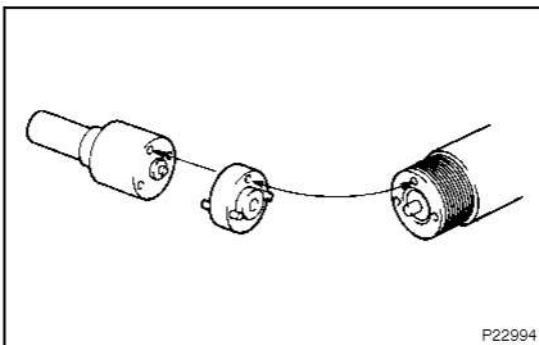

HINT:

Align the holes of the nozzle body, tip packing and nozzle holder body.

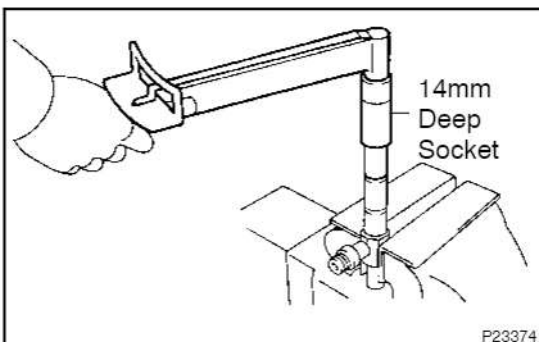

(b) Using a 14 mm deep socket wrench, torque the retaining nut.

Torque: 29.4 N·m (300 kgf·cm, 22 ft·lbf)

NOTICE:

Over torquing could cause the nozzle deformation and the needle adhesion or other defects.

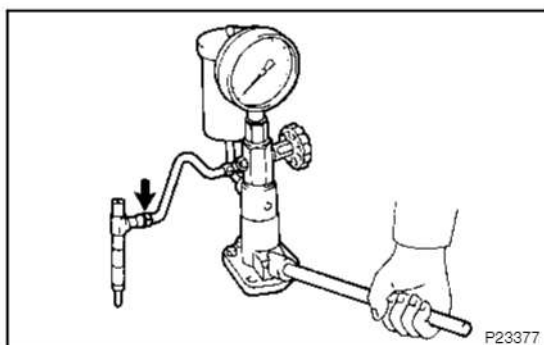

- (c) Install the injection nozzle to the injection nozzle hand tester and bleed air from the union nut.

CAUTION:

Do not place your finger over the nozzle injection hole.

- (d) Pump the tester handle a few times as fast as possible to discharge the carbon from the injection hole.

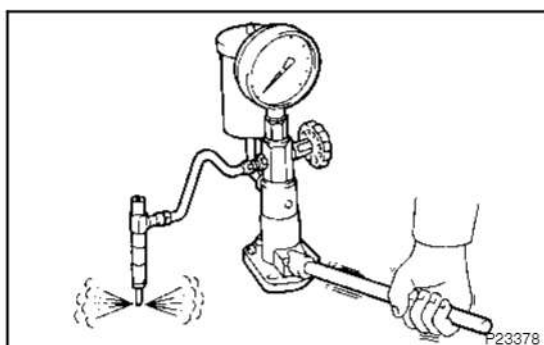

- (e) Pump the tester handle slowly and observe the pressure gauge.
 (f) Read the pressure gauge just as the injection pressure begins to drop.

No.2 opening pressure (Inspection pressure):

27,460 – 28,440 kPa

(274.6 – 284.4 kgf/cm², 3,983 – 4,125 psi)

HINT:

- Proper nozzle operation can be determined by a swishing sound.
- With the SST installation, the inspection adjusting valve of No.2 opening pressure has become higher than 27,459 kPa (280 kgf/cm², 3,982 psi).

If the opening pressure is not as specified, disassemble the nozzle and change the No.1 pressure spring washer (adjusting shim).

No.1 pressure spring washer (adjusting shim) thickness:

mm (in.)	mm (in.)	mm (in.)
0.700 (0.0276)	1.225 (0.0482)	1.625 (0.0640)
0.750 (0.0295)	1.250 (0.0492)	1.650 (0.0650)
0.800 (0.0315)	1.275 (0.0502)	1.675 (0.0659)
0.850 (0.0335)	1.300 (0.0512)	1.700 (0.0669)
0.900 (0.0354)	1.325 (0.0521)	1.725 (0.0679)
0.950 (0.0374)	1.350 (0.0531)	1.750 (0.0689)
0.975 (0.0384)	1.375 (0.0541)	1.775 (0.0699)
1.000 (0.0394)	1.400 (0.0551)	1.800 (0.0709)
1.025 (0.0404)	1.425 (0.0561)	1.850 (0.0728)
1.050 (0.0413)	1.450 (0.0571)	1.900 (0.0748)
1.075 (0.0423)	1.475 (0.0581)	1.950 (0.0768)
1.100 (0.0433)	1.500 (0.0591)	2.000 (0.0787)
1.125 (0.0443)	1.525 (0.0600)	2.050 (0.0807)
1.150 (0.0453)	1.550 (0.0610)	2.100 (0.0827)
1.175 (0.0463)	1.575 (0.0620)	2.150 (0.0846)
1.200 (0.0472)	1.600 (0.0630)	-

HINT:

- Varying the adjusting shim thickness by 0.025 mm (0.0010 in.) changes the injection pressure by about 373 kpa (3.8 kgf/cm², 54 psi).
- Only one adjusting shim should be used.

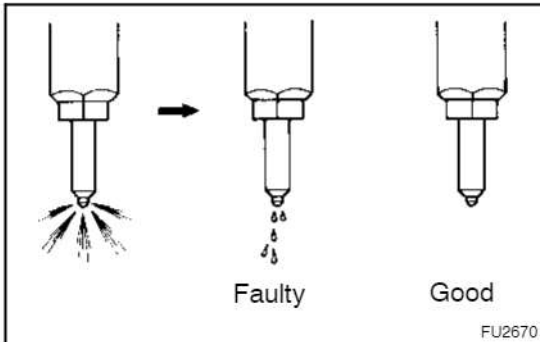

- (g) There should be no dripping after injection.
 (h) After checking the No.2 opening pressure, disassemble the nozzle.

2. ADJUST NO.1 OPENING PRESSURE

- (a) Assemble the nozzle holder body, No.2 pressure spring washer (adjusting shim) for adjustment of No.1 opening pressure, No.1 pressure spring, pressure pin, No.1 pressure spring seat, No.1 pressure spring washer (adjusting shim) selected in step 1 above, No.2 pressure spring, No.2 pressure spring seat, tip packing, straight pins, No.3 pressure spring washer and nozzle assembly, and finger tighten the retaining nut.

HINT:

- Align the holes of the nozzle body, the distance piece and the nozzle holder body.
 - When the thickness of the original used adjusting shim is not known, use a shim 1.5 mm (0.59 in.) thick instead.
- (b) Read the pressure gauge just as the injection pressure begins to drop. (See steps (b) to (f) in step 1 above)

No.1 opening pressure:

17,650 – 18,630 kpa

(176.5 – 186.3 kgf/cm², 2,560 – 2,702 psi)

HINT:

Proper nozzle operation can be determined by a swishing sound.

If the opening pressure is not as specified, disassemble the nozzle and change the No.2 pressure spring washer (adjusting shim).

No.2 pressure spring washer (adjusting shim) thickness:

mm (in.)	mm (in.)	mm (in.)
0.800 (0.0315)	1.275 (0.0502)	1.750 (0.0689)
0.825 (0.0325)	1.300 (0.0512)	1.775 (0.0699)
0.850 (0.0335)	1.325 (0.0521)	1.800 (0.0709)
0.875 (0.0344)	1.350 (0.0531)	1.825 (0.0719)
0.900 (0.0354)	1.375 (0.0541)	1.850 (0.0728)
0.925 (0.0364)	1.400 (0.0551)	1.875 (0.0738)
0.950 (0.0374)	1.425 (0.0561)	1.900 (0.0748)
0.975 (0.0384)	1.450 (0.0571)	1.925 (0.0758)
1.000 (0.0394)	1.475 (0.0581)	1.950 (0.0768)
1.025 (0.0404)	1.500 (0.0591)	1.975 (0.0778)
1.050 (0.0413)	1.525 (0.0600)	2.000 (0.0787)
1.075 (0.0423)	1.550 (0.0610)	2.025 (0.0797)
1.100 (0.0433)	1.575 (0.0620)	2.050 (0.0807)
1.125 (0.0443)	1.600 (0.0630)	2.075 (0.0817)
1.150 (0.0453)	1.625 (0.0640)	2.100 (0.0827)
1.175 (0.0463)	1.650 (0.0650)	2.125 (0.0837)
1.200 (0.0472)	1.675 (0.0659)	2.150 (0.0846)
1.225 (0.0482)	1.700 (0.0669)	2.175 (0.0856)
1.250 (0.0492)	1.725 (0.0679)	2.200 (0.0866)

HINT:

- Varying the adjusting shim thickness by 0.025 mm (0.0010 in.) changes the injection pressure by about 373 kpa (3.8 kgf/cm², 54 psi).
 - Only one adjusting shim should be used.
- (c) There should be no dripping after injection (See step (g) in step 1 above).

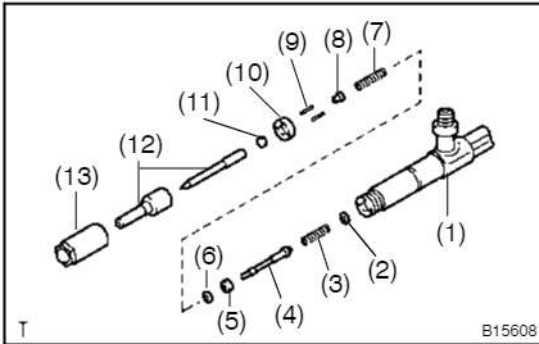

REASSEMBLY

ASSEMBLY INJECTION NOZZLE HOLDER

(a) Assemble these parts:

- (1) Nozzle holder body
- (2) No.2 pressure spring washer (Adjusting shim)
- (3) No.1 pressure spring
- (4) Pressure pin
- (5) No.1 pressure spring seat
- (6) No.1 pressure spring washer (Adjusting shim)
- (7) No.2 pressure spring
- (8) No.2 pressure spring seat
- (9) Straight pins
- (10) Tip packing
- (11) No.3 pressure spring washer
- (12) Nozzle assembly
- (13) Retaining nut

NOTICE:

Do not assemble the No.1 pressure spring, pressure pin and adjusting shim for adjustment of the No.1 opening pressure.

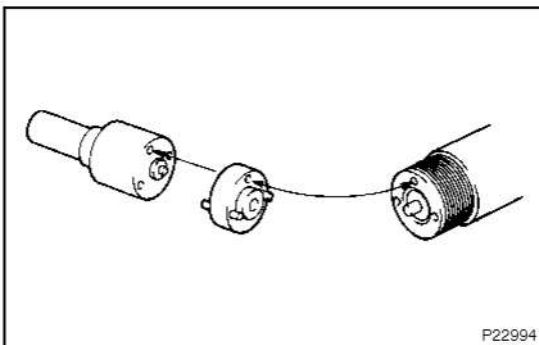

HINT:

- Align the holes of the nozzle body, the distance piece and the nozzle holder body.
- When the thickness of the original used adjusting shim is not known, use a shim 1.5 mm (0.59 in.) thick instead.

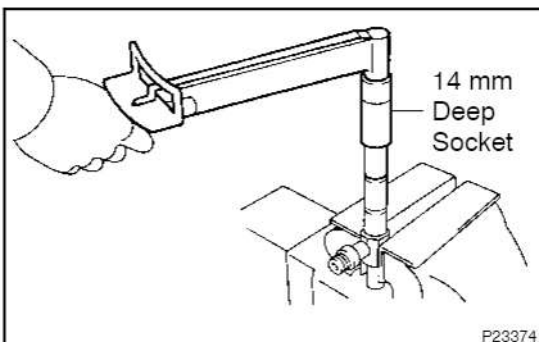

(b) Using a 14 mm deep socket wrench, torque the retaining nut.

Torque: 29.4 N·m (300 kgf·cm, 22 ft·lbf)

NOTICE:

Over torquing could cause the nozzle deformation and the needle adhesion or other defects.

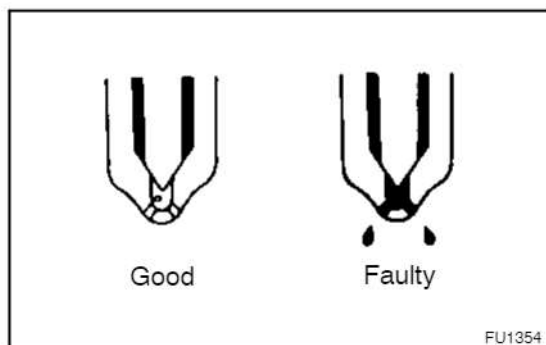

TEST

1. LEAKAGE TEST

While maintaining pressure at about 981 – 1,961 kPa (10 – 20 kgf/cm² 142 – 284 psi), below No.1 opening pressure (adjust by tester handle), check that there is not dripping for 10 seconds from the injection hole or around the retaining nut.

If the nozzle drips within 10 seconds, replace or clean and overhaul the nozzle assembly.

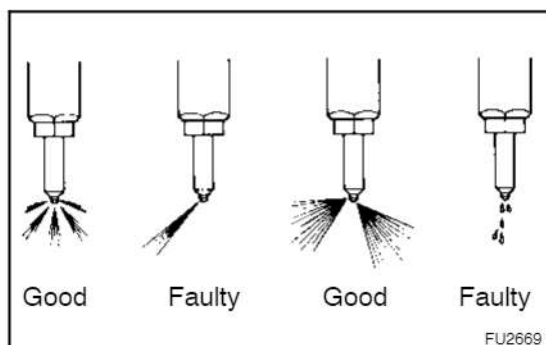

2. SPRAY PATTERN TEST

- (a) The injection nozzle should shudder at a certain pumping speed between 15 – 60 times (old nozzle) or 30 – 60 times (new nozzle) per minute.
- (b) Check the spray pattern during shuddering.
If the spray pattern is not correct during shuddering, the nozzle must be replaced or cleaned.

INSTALLATION

1. INSTALL INJECTION NOZZLES

- (a) Install a new O-ring to the injection nozzle.
- (b) Place 6 new nozzle seats into the injection nozzle holes of the cylinder head.

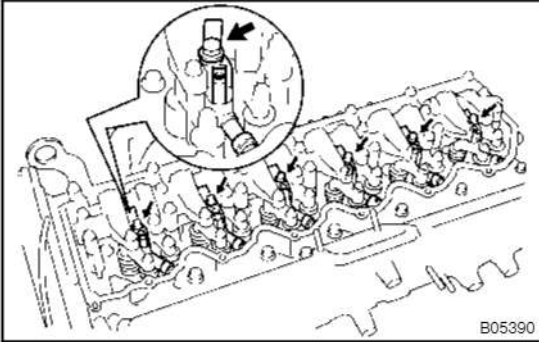

- (c) Install the injection nozzles with the nozzle holder clamp, washer and bolt to the cylinder head.

Torque: 25 N·m (255 kgf·cm, 18 ft·lbf)

- (d) Inspect the valve clearance. (See pub No. RM617E on page EM-9)

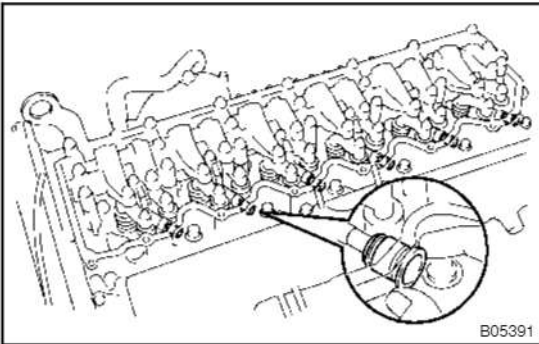

2. INSTALL NOZZLE HOLDER SEALS

Install the 6 new nozzle holder seals to the cylinder head with your hand.

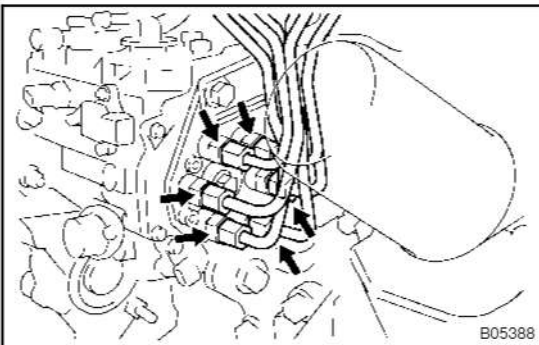

3. INSTALL INJECTION PIPES

- (a) Place the 2 clamps on the intake manifold.
- (b) Attach the 6 injection pipes to the injection nozzle and injection pump.
- (c) Tighten the 6 union nuts to the injection pump.

Torque: 24.5 N·m (250 kgf·cm, 18 ft·lbf)

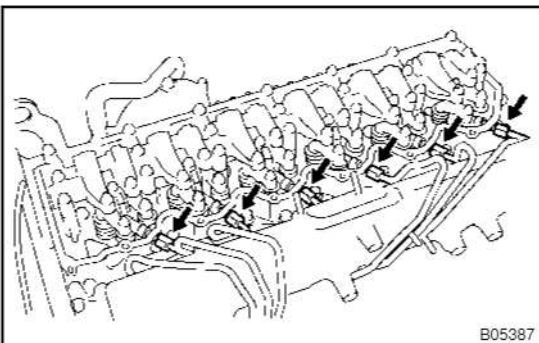

- (d) Tighten the 6 union nuts to the injection nozzle.
- Torque: 24.5 N·m (250 kgf·cm, 18 ft·lbf)**

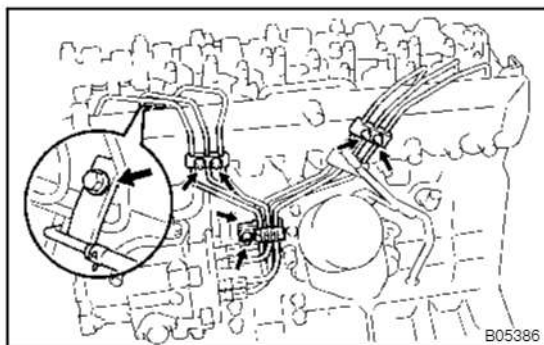

- (e) Install the 2 clamps with the 2 nuts.
Torque: 6.4 N·m (65 kgf·cm, 56 in·lbf)
- (f) Install the clamp with the bolt and nut.
Torque: 6.4 N·m (65 kgf·cm, 56 in·lbf)
- (g) Install the No.3 nozzle leakage pipe with the bolt.
Torque: 19.6 N·m (200 kgf·cm, 15 ft·lbf)

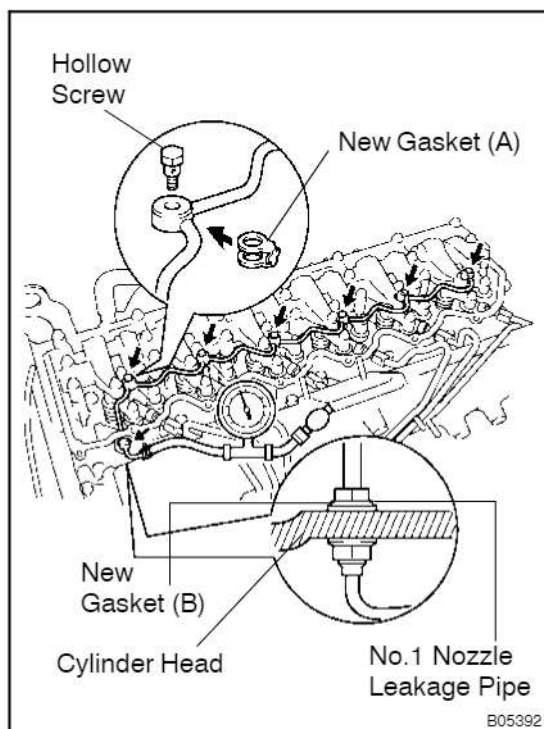

4. INSTALL NO.1 NOZZLE LEAKAGE PIPE

- (a) Install the 7 new gaskets, No.1 nozzle leakage pipe to the cylinder head, injection nozzle with the 6 hollow screw and nut.
Torque:
Hollow screw: 11.3 N·m (115 kgf·cm, 8 ft·lbf)
Nut: 19 N·m (186 kgf·cm, 14 ft·lbf)

NOTICE:

Install the gasket (A) so that its connecting part is between the pipe as shown in the illustration.

- (b) Using SST (turbocharger pressure gauge), apply the SST to the fuel return side of the No.1 nozzle leakage pipe, and maintain 49 kPa (0.5 kgf/cm², 7.1 psi) of pressure for 10 seconds to check that there are no leaks.
SST 09992-00242
 - (c) Connect the fuel return hose to the No.1 nozzle leakage pipe.
5. **INSTALL NO.1 AND NO.2 CYLINDER HEAD COVERS (See page EM-23)**
 6. **INSTALL EGR W/COOLER PIPE SUB-ASSY (See page EM-23)**
 7. **INSTALL INTAKE PIPE (See page EM-23)**
 8. **START ENGINE AND CHECK FOR FUEL LEAKAGE**

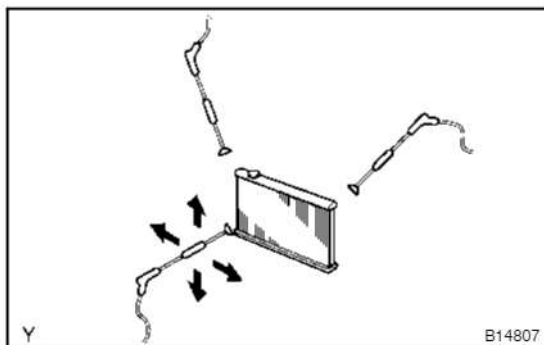

RADIATOR ON-VEHICLE CLEANING

CO180-01

INSPECT FINS FOR BLOCKAGE

If fins are clogged, wash them with water or a steam cleaner and dry with compressed air.

NOTICE:

- If the distance between the steam cleaner and the core is too close, there is a possibility of damaging the fin, so keep the following injection distance.

Injection Pressure	Injection Distance
2,942 – 4,903 kpa (30 – 50 kg/cm ² : 427 – 711 psi)	300 mm (11.811 in)
4,903 – 7,845 kpa (50 – 80 kg/cm ² : 711 – 1,138 psi)	500 mm (19.685 in)

- If the fins are bent, straighten them with a screwdriver or pliers.
- Never apply water directly onto the electronic components.

CHARGING SYSTEM

PRECAUTION

CH0AA-02

- Check that the battery cables are connected to the correct terminals.
- Disconnect the battery cables when the battery is given a quick charge.
- Do not perform tests with a high voltage insulation resistance tester.
- Never disconnect the battery while the engine is running.

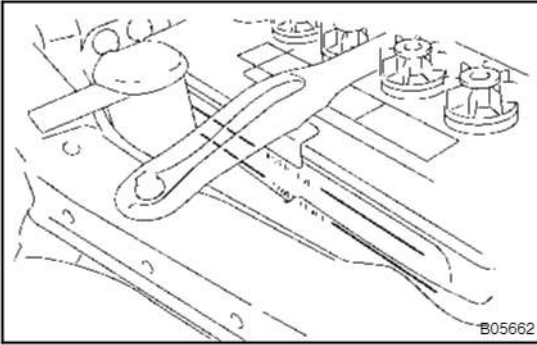

ON-VEHICLE INSPECTION

1. CHECK BATTERY ELECTROLYTE LEVEL

Check the electrolyte quantity of each cell.

Maintenance-Free Battery:

If under the lower level, replace the battery (or add distilled water if possible) and check the charging system.

Except Maintenance-Free Battery:

If under the lower level, add distilled water.

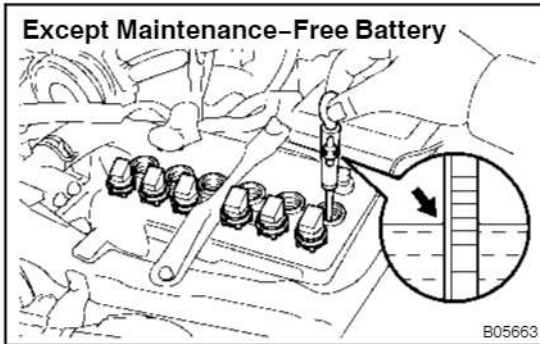

Except Maintenance-Free Battery

2. Except Maintenance-Free Battery:

CHECK BATTERY SPECIFIC GRAVITY

Check the specific gravity of each cell.

Standard specific gravity:

1.25 - 1.29 at 20°C (68°F)

If the specific gravity is less than specification, charge the battery.

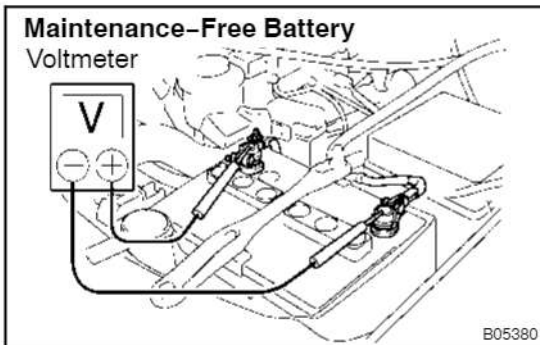

Maintenance-Free Battery

Voltmeter

3. Maintenance-Free Battery:

CHECK BATTERY VOLTAGE

(a) After having driven the vehicle and in the case that 20 minutes have not passed after having stopped the engine, turn the ignition switch ON and turn on the electrical system (headlight, blower motor, rear defogger etc.) for 60 seconds to remove the surface charge.

(b) Turn the ignition switch OFF and turn off the electrical systems.

(c) Measure the battery voltage between the negative (-) and positive (+) terminals of the battery.

Standard voltage:

12.5 - 12.9 V at 20°C (68°F)

If the voltage is less than specification, charge the battery.

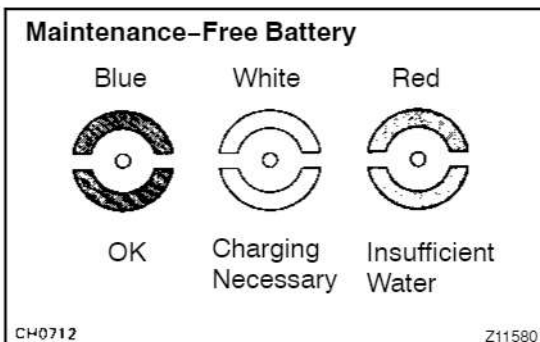

Maintenance-Free Battery

Blue

White

Red

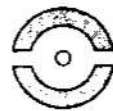

OK

Charging
Necessary

Insufficient
Water

CH0712

Z11580

HINT:

Check the indicator as shown in the illustration.

4. CHECK BATTERY TERMINALS, FUSIBLE LINK AND FUSES

(a) Check that the battery terminals are not loose or corroded.

(b) Check the fusible link and fuses for continuity.

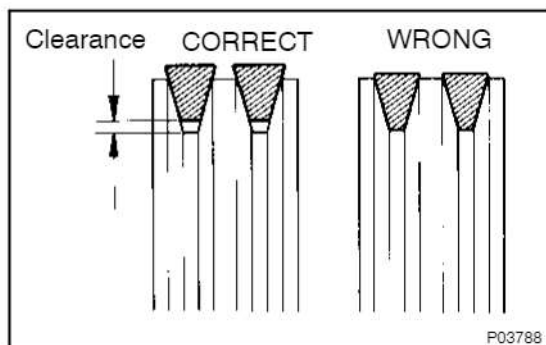

5. INSPECT DRIVE BELT

- (a) Visually check the drive belt for cracks, oiliness or wear. Check that the belt does not touch the bottom of the pulley groove.

If necessary, replace the drive belts as a set.

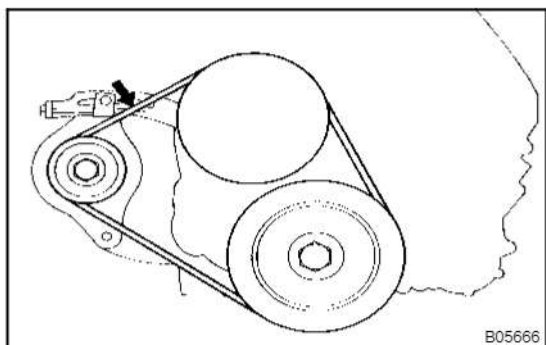

- (b) Check the drive belt deflection by pressing on the belt at the points indicated in the illustration with 98 N (10 kgf, 22 lbf) of pressure.

Drive belt deflection:

New belt 6 – 7 mm (0.24 – 0.28 in.)

Used belt 8 – 11 mm (0.31 – 0.43 in.)

If necessary, adjust the drive belt deflection.

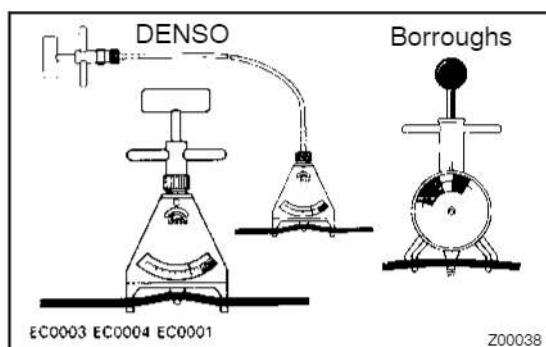

- (c) Using a belt tension gauge, measure the belt tension.

Belt tension gauge:

Denso BTG-20 (95506-00020)

Borroughs No. BT-33-73F

Drive belt tension:

New belt 441 – 539 N (45 – 55 kgf)

Used belt 196 – 343 N (20 – 35 kgf)

If the belt tension is not as specified, adjust it.

HINT:

- "New belt" refers to a belt which has been used less than 5 minutes on a running engine.
- "Used belt" refers to a belt which has been used on a running engine for 5 minutes or more.
- After installing a belt, check that it fits properly in the ribbed grooves.
- Check with your hand to confirm that the belt has not slipped out of the groove on the bottom of the pulley.
- After installing a new belt, run the engine for about 5 minutes and recheck the belt tension.

6. VISUALLY CHECK ALTERNATOR WIRING AND LISTEN FOR ABNORMAL NOISES

- (a) Check that the wiring is in good condition.
- (b) Check that there is no abnormal noise from the alternator while the engine is running.

7. INSPECT DISCHARGE WARNING LIGHT CIRCUIT

- (a) Turn the ignition switch "ON". Check that the discharge warning light comes on.
 - (b) Start the engine. Check that the light goes off.
- If the light does not operate as specified, troubleshoot the discharge warning light circuit.

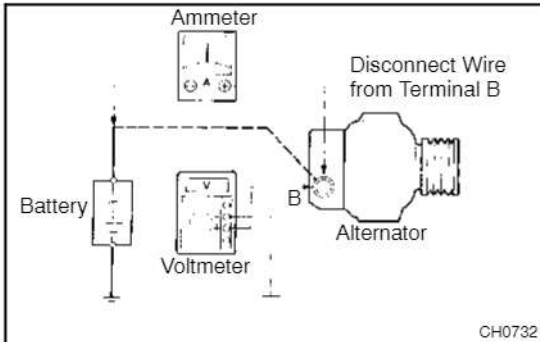
**8. INSPECT CHARGING CIRCUIT WITHOUT LOAD****HINT:**

If a battery/alternator tester is available, connect the tester to the charging circuit as per manufacturer's instructions.

- (a) If a tester is not available, connect a voltmeter and ammeter to the charging circuit as follows:
 - Disconnect the wire from terminal B of the alternator and connect it to the negative (-) lead of the ammeter.
 - Connect the positive (+) lead of the ammeter to terminal B of the alternator.
 - Connect the positive (+) lead of the voltmeter to terminal B of the alternator.
 - Ground the negative (-) lead of the voltmeter.
- (b) Check the charging circuit as follows:
With the engine running from idle to 2,000 rpm, check the reading on the ammeter and voltmeter.

Standard amperage:**10 A or less****Standard voltage:****13.2 - 14.8 V at 115° C (239° F)**

If the voltmeter reading is more than the standard voltage, replace the voltage regulator.

9. INSPECT CHARGING CIRCUIT WITH LOAD

- (a) With the engine running at 2,000 rpm, turn on the high beam headlights and place the heater blower switch at "HI".
- (b) Check the reading on the ammeter.

Standard amperage:**30 A or more**

If the ammeter reading is less than the standard amperage, repair the alternator.

HINT:

If the battery is fully charged, the indication will sometimes be less than the standard amperage.

ALTERNATOR COMPONENTS

CH0AC-09

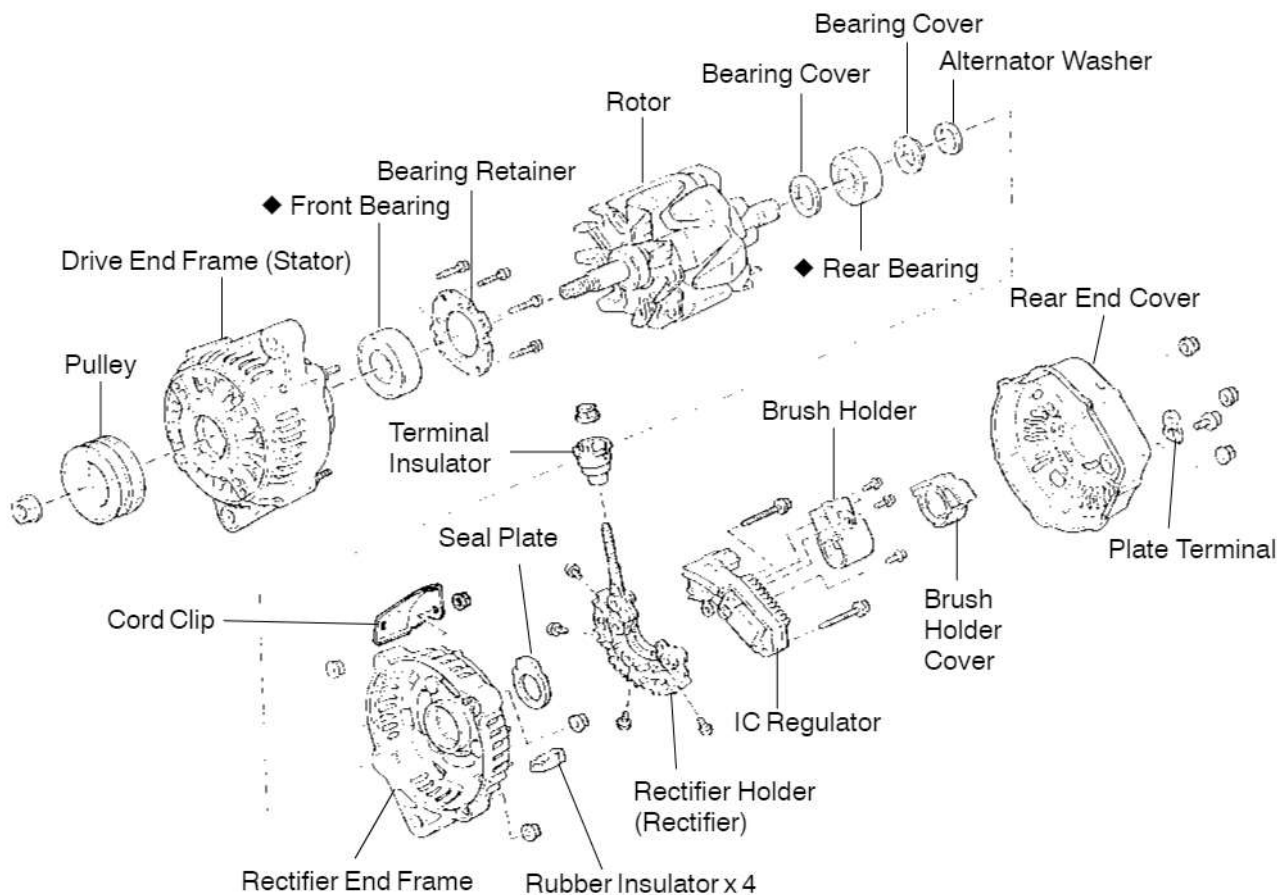

◆ Non-reusable part

B15012

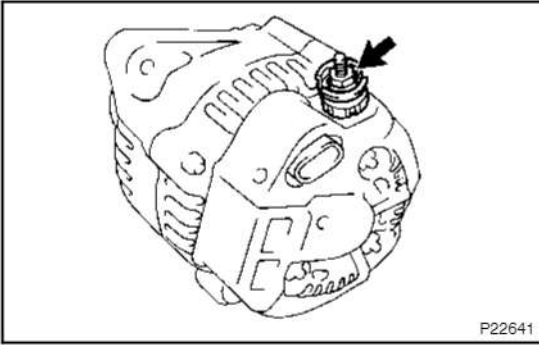

DISASSEMBLY

1. REMOVE REAR END COVER

- (a) Remove the nut and terminal insulator.

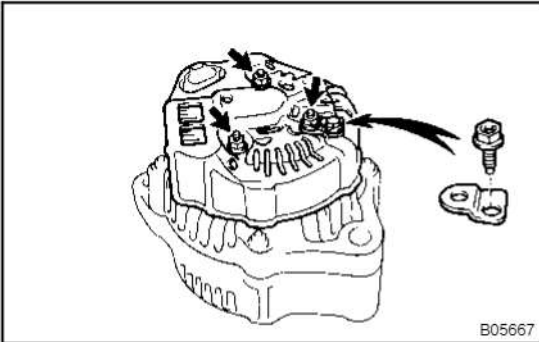

- (b) Remove the 3 nuts, bolt, plate terminal and rear end cover.

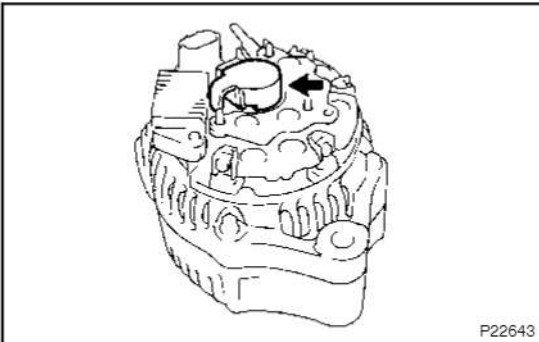

2. REMOVE BRUSH HOLDER AND IC REGULATOR

- (a) Remove the brush holder cover from the brush holder.

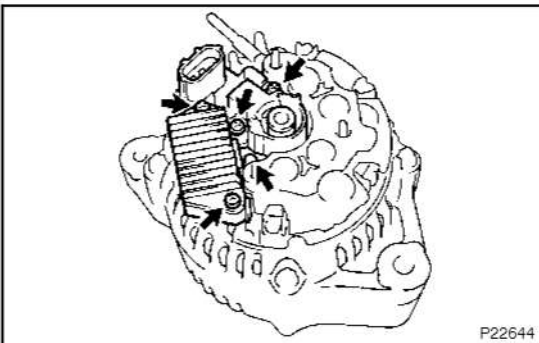

- (b) Remove the 5 screws, brush holder and IC regulator.

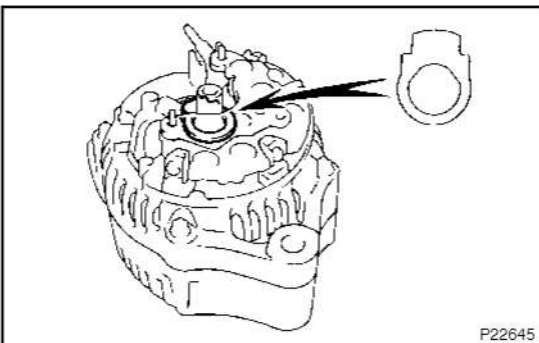

- (c) Remove the seal plate from the rectifier end frame.

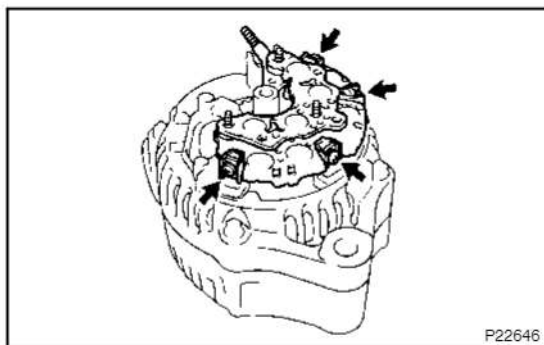

3. REMOVE RECTIFIER HOLDER

- (a) Remove the 4 screws and rectifier holder.

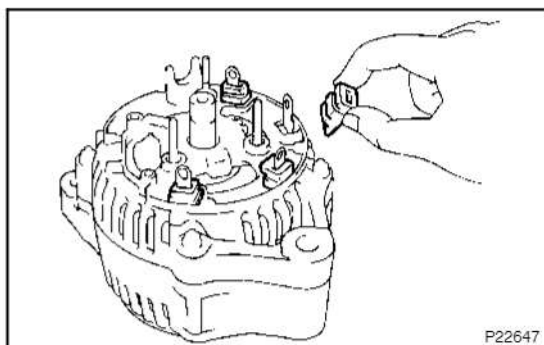

- (b) Remove the 4 rubber insulators.

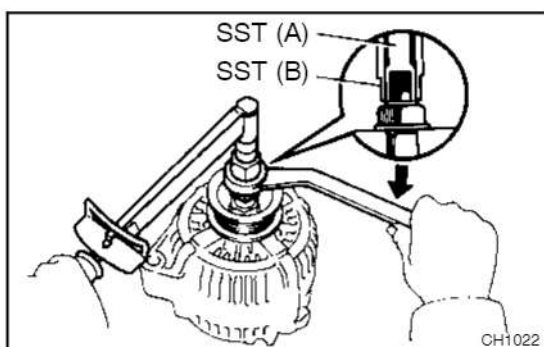

4. REMOVE PULLEY

- (a) Hold SST (A) with a torque wrench, and tighten SST (B) clockwise to the specified torque.

SST 09820-63011

Torque: 39 N·m (400 kgf·cm, 29 ft·lbf)

- (b) Check that SST (A) is secured to the rotor shaft.

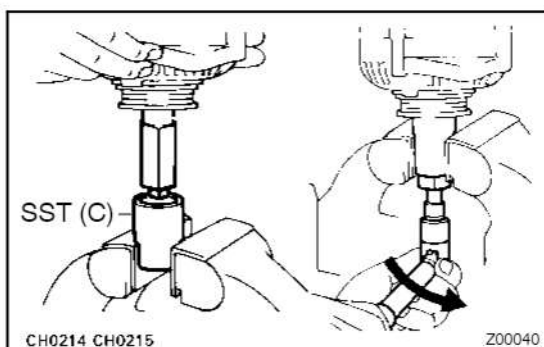

- (c) As shown in the illustration, mount SST (C) in a vise, and install the alternator to SST (C).

- (d) To loosen the pulley nut, turn SST (A) in the direction shown in the illustration.

NOTICE:

To prevent damage to the rotor shaft, do not loosen the pulley nut more than one-half of a turn.

- (e) Remove the alternator from SST (C).
 (f) Turn SST (B), and remove SST (A and B).
 (g) Remove the pulley nut and pulley.

5. REMOVE RECTIFIER END FRAME

- (a) Remove the 4 nuts and cord clip.

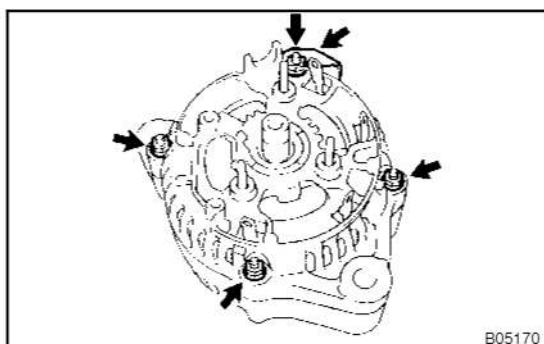

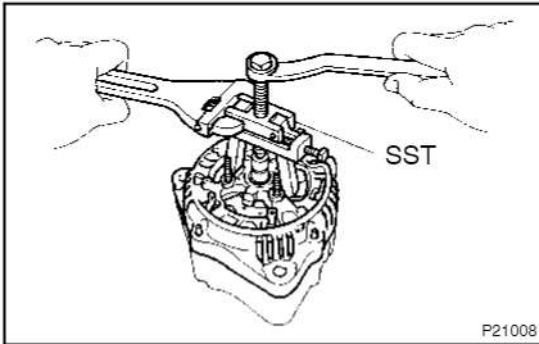

- (b) Using SST, remove the rectifier end frame.
SST 09286-46011

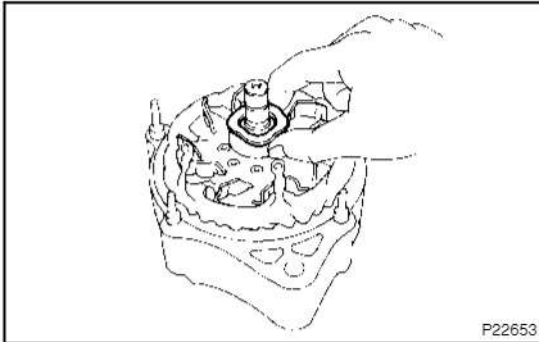

- (c) Remove the alternator washer.

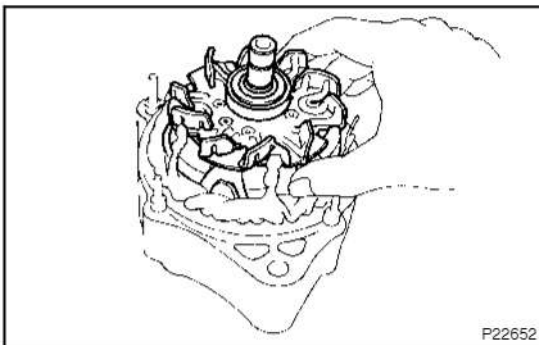

6. REMOVE ROTOR FROM DRIVE END FRAME

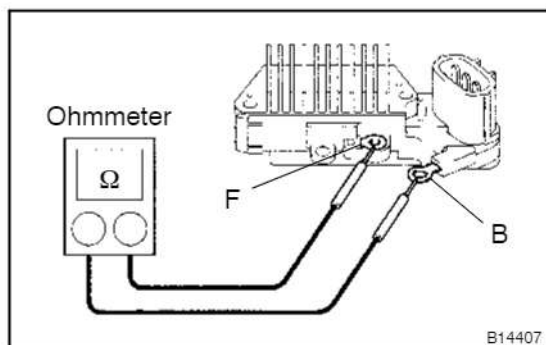

INSPECTION

1. INSPECT VOLTAGE REGULATOR

- (a) Using an ohmmeter, check the continuity between terminals F and B.

Standard:

When the positive and negative poles between terminals F and B are exchanged, there is continuity in one way but no continuity in another way.

If the continuity is not as specified, replace the voltage regulator.

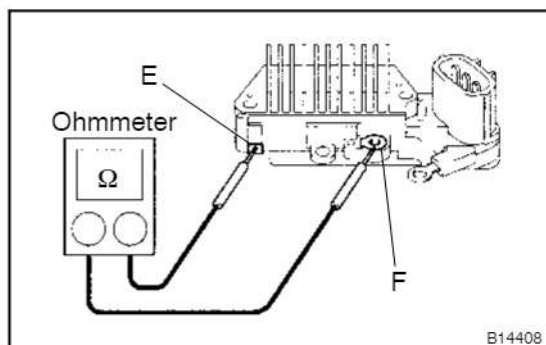

- (b) Using an ohmmeter, check the continuity between terminals F and E.

Standard:

When the positive and negative poles between terminals F and E are exchanged, there is continuity in one way but no continuity in another way.

If the continuity is not as specified, replace the voltage regulator.

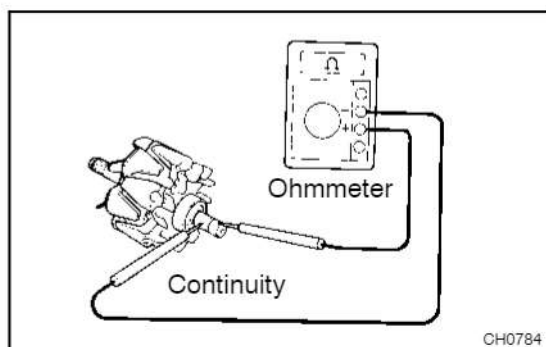

2. INSPECT ROTOR FOR OPEN CIRCUIT

Using an ohmmeter, check that there is continuity between the slip rings.

Standard resistance:

2.1 - 2.5 Ω at 20°C (68°F)

If there is no continuity, replace the rotor.

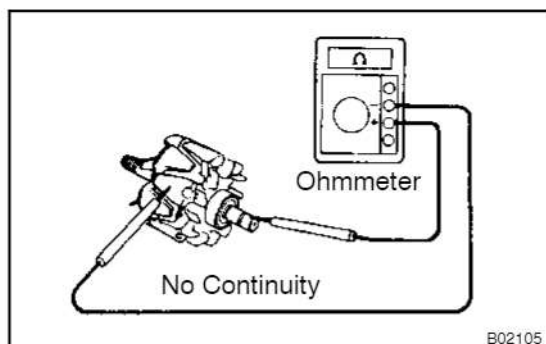

3. INSPECT ROTOR FOR GROUND

Using an ohmmeter, check that there is no continuity between the slip ring and rotor.

If there is continuity, replace the rotor.

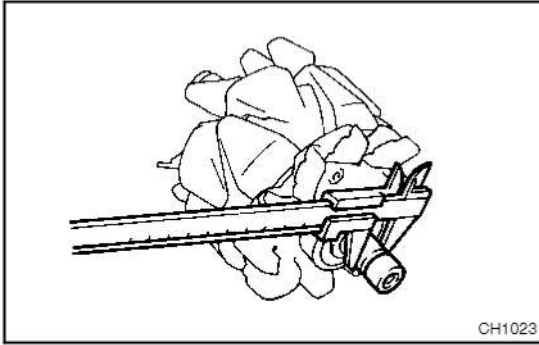

4. INSPECT SLIP RINGS

- (a) Check that the slip rings are not rough or scored. If rough or scored, replace the rotor.
- (b) Using vernier calipers, measure the slip ring diameter.

Standard diameter:

14.2 – 14.4 mm (0.559 – 0.567 in.)

Minimum diameter:

12.8 mm (0.504 in.)

If the diameter is less than minimum, replace the rotor.

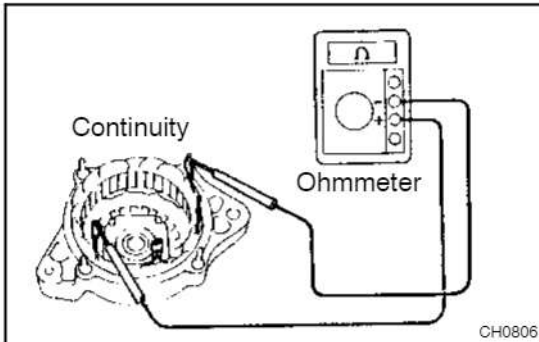

5. INSPECT STATOR FOR OPEN CIRCUIT

Using an ohmmeter, check that there is continuity between the coil leads.

If there is no continuity, replace the drive end frame assembly.

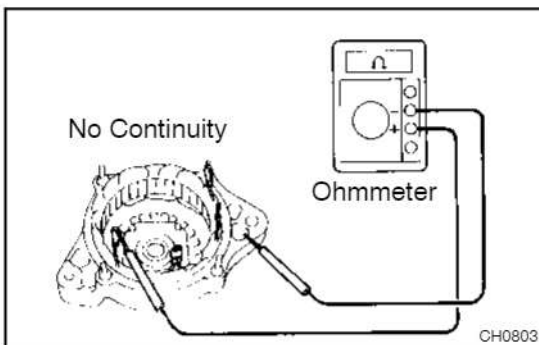

6. INSPECT STATOR FOR GROUND

Using an ohmmeter, check that there is no continuity between the coil lead and drive end frame.

If there is continuity, replace the drive end frame assembly.

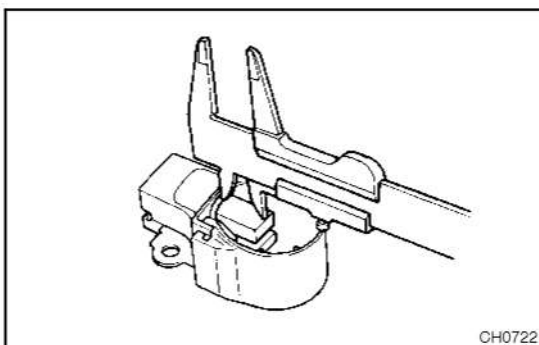

7. INSPECT EXPOSED BRUSH LENGTH

Using a scale and vernier caliper, measure the exposed brush length.

Standard exposed length:

10.5 mm (0.413 in.)

Minimum exposed length:

1.5 mm (0.059 in.)

If the exposed length is less than minimum, replace the brush holder.

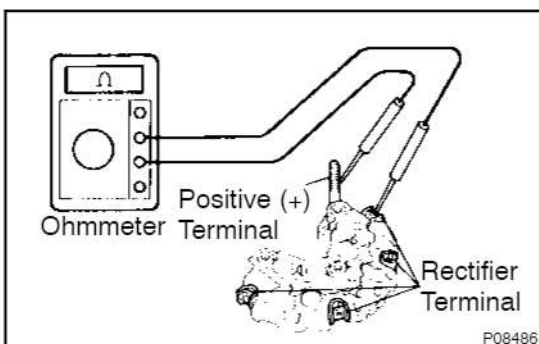

8. INSPECT POSITIVE RECTIFIER

- (a) Using an ohmmeter, connect one tester probe to the positive (+) terminal and the other to each rectifier terminal.
- (b) Reverse the polarity of the tester probes and repeat step (a).
- (c) Check that one shows continuity and the other shows no continuity.

If continuity is not as specified, replace the rectifier holder.

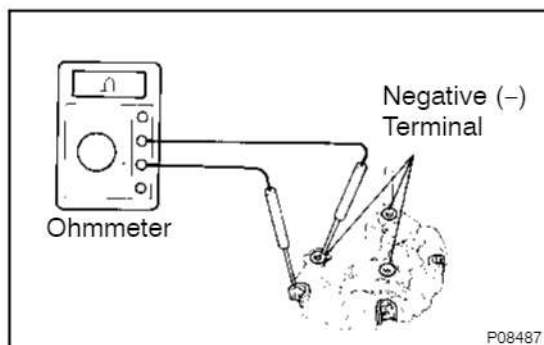

9. INSPECT NEGATIVE RECTIFIER

- (a) Using an ohmmeter, connect one tester probe to each negative (-) terminal and the other to each rectifier terminal.
- (b) Reverse the polarity of the tester probes and repeat step (a).
- (c) Check that one shows continuity and the other shows no continuity.

If continuity is not as specified, replace the rectifier holder.

10. INSPECT FRONT AND REAR BEARING

Check that the bearing is not rough or worn.

If necessary, replace the bearing.

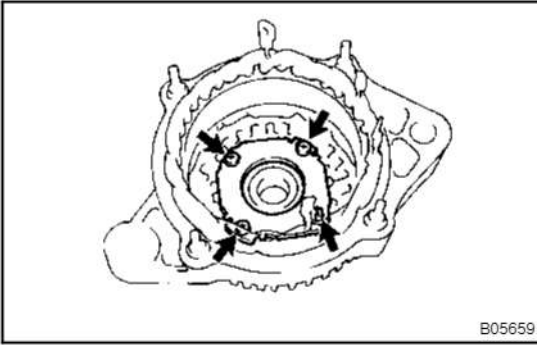

REPLACEMENT

1. REPLACE FRONT BEARING

- (a) Remove the 4 screws and bearing retainer.

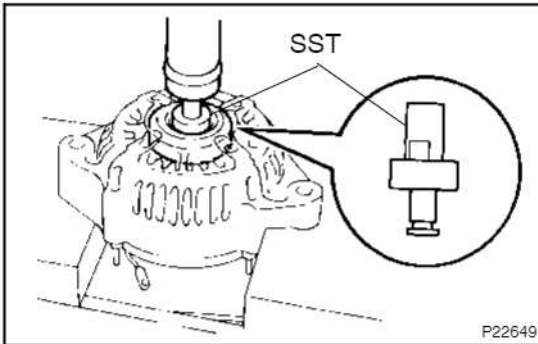

- (b) Using SST and a press, press out the bearing.
SST 09950-60010 (09951-00260, 09952-06010)

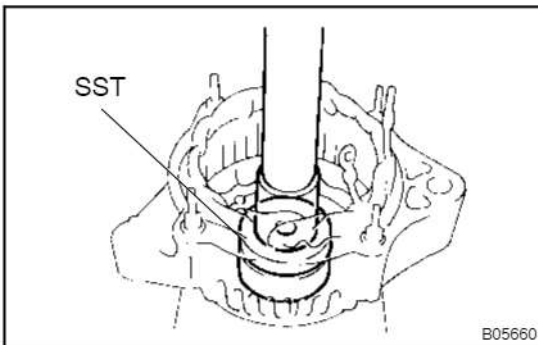

- (c) Using SST and a press, press in a new bearing.
SST 09950-60010 (09951-00500)
- (d) Install the bearing retainer with the 4 screws.
Torque: 3.0 N·m (31 kgf·cm, 27 in·lbf)

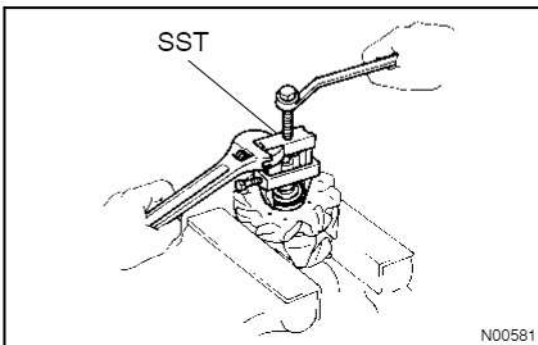

2. REPLACE REAR BEARING

- (a) Using SST, remove the bearing cover (outside) and bearing.
SST 09820-00021

NOTICE:

Be careful not to damage the fan.

- (b) Remove the bearing cover (inside).

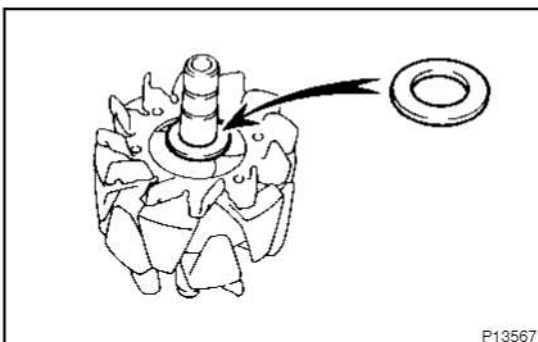

- (c) Place the bearing cover (inside) on the rotor.

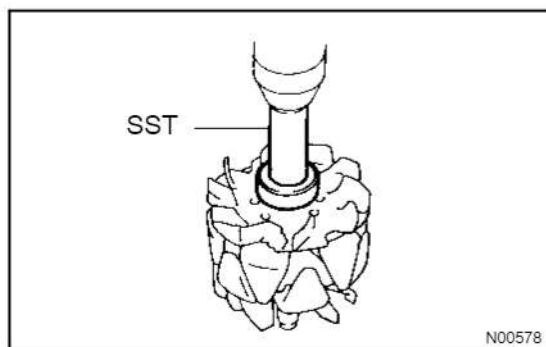

- (d) Using SST and a press, press in a new bearing.
SST 09820-00031

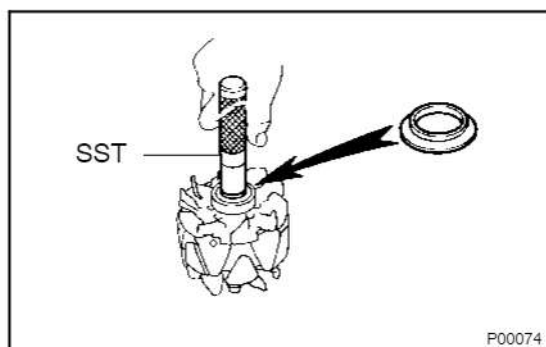

- (e) Using SST, push in the bearing cover (outside).
SST 09285-76010

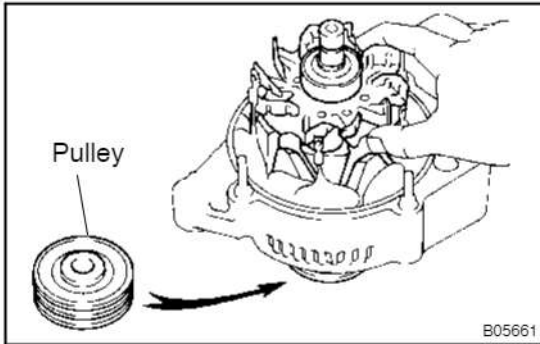

REASSEMBLY

1. PLACE DRIVE END FRAME ON PULLEY
2. INSTALL ROTOR TO DRIVE END FRAME

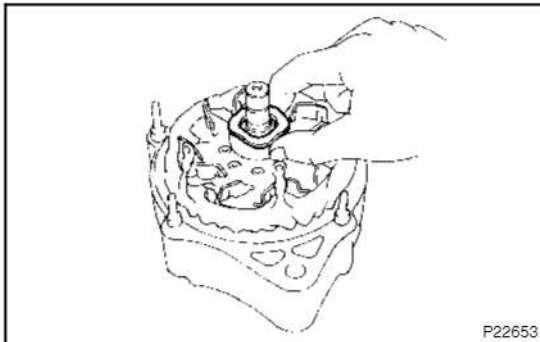

3. INSTALL RECTIFIER END FRAME
 - (a) Place the alternator washer on the rotor.

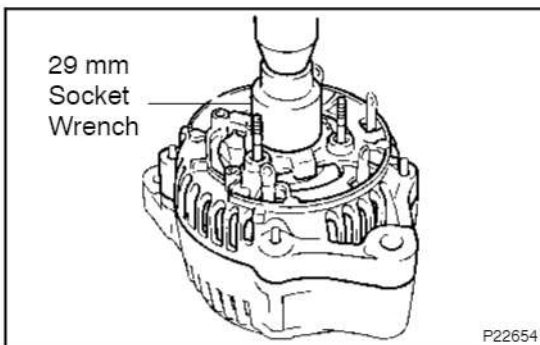

- (b) Using a 29 mm socket wrench and press, slowly press in the rectifier end frame.

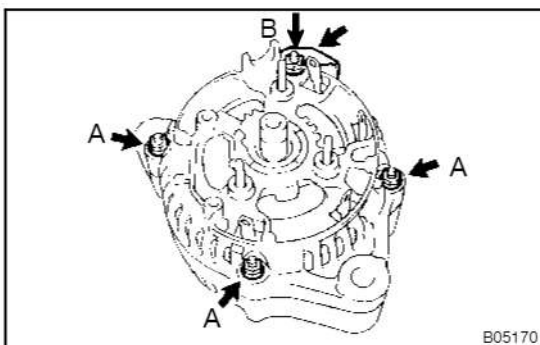

- (c) Install the cord clip and 4 nuts.

Torque:

A: 4.5 N·m (46 kgf·cm, 40 in.·lbf)

B: 5.4 N·m (55 kgf·cm, 48 in.·lbf)

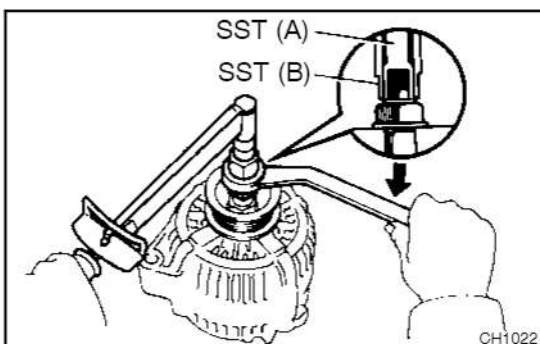

4. INSTALL PULLEY
 - (a) Install the pulley to the rotor shaft by tightening the pulley nut by hand.
 - (b) Hold SST (A) with a torque wrench, and tighten SST (B) clockwise to the specified torque.

SST 09820-63011

Torque: 39 N·m (400 kgf·cm, 29 ft·lbf)
 - (c) Check that SST (A) is secured to the pulley shaft.

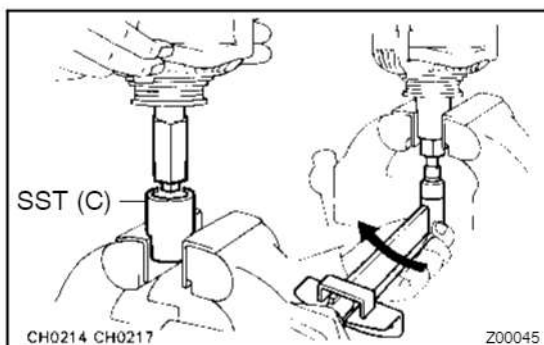

- (d) As shown in the illustration, mount SST (C) in a vise, and install the alternator to SST (C).
- (e) To torque the pulley nut, turn SST (A) in the direction shown in the illustration.
Torque: 110.5 N·m (1,125 kgf·cm, 81 ft·lbf)
- (f) Remove the alternator from SST (C).
- (g) Turn SST (B), and remove SST (A and B).

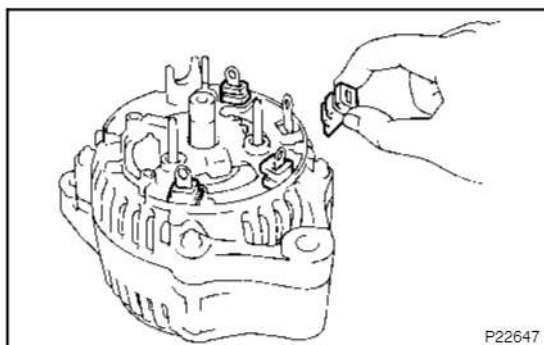

5. INSTALL RECTIFIER HOLDER

- (a) Install the 4 rubber insulators on the lead wires.

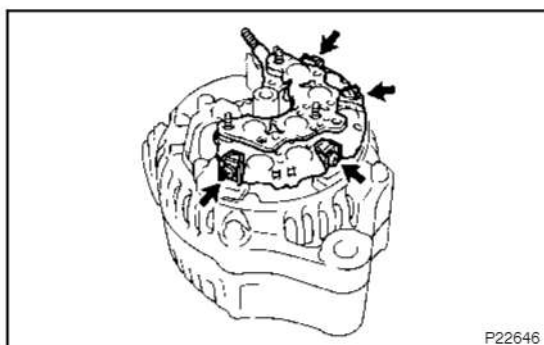

- (b) Install the rectifier holder while pushing it with the 4 screws.

Torque: 2.94 N·m (30 kgf·cm, 26 in.·lbf)

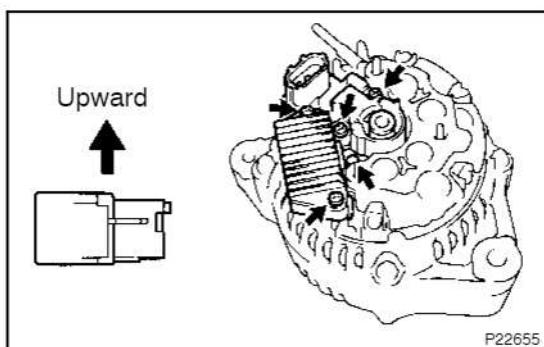

6. INSTALL IC REGULATOR AND BRUSH HOLDER

- (a) Place the seal plate on the rectifier end frame.
- (b) Place the IC regulator and brush holder on the rectifier end frame.

NOTICE:

Be careful of the holder installation direction.

- (c) Install the 5 screws.
Torque: 2.0 N·m (20 kgf·cm, 18 in.·lbf)
- (d) Place the brush holder cover on the brush holder.

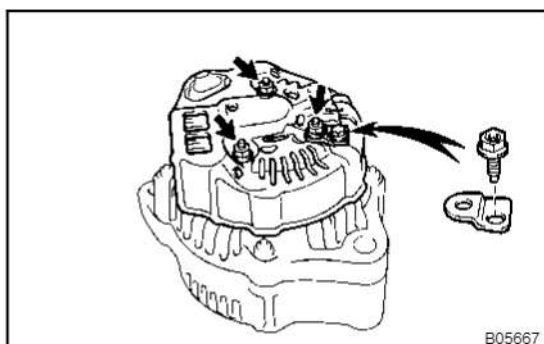

7. INSTALL REAR END COVER

- (a) Install the rear end cover and plate terminal with the 3 nuts and screw.

Torque:

Screw: 3.85 N·m (39 kgf·cm, 34 in.·lbf)

Nuts: 4.4 N·m (45 kgf·cm, 39 in.·lbf)

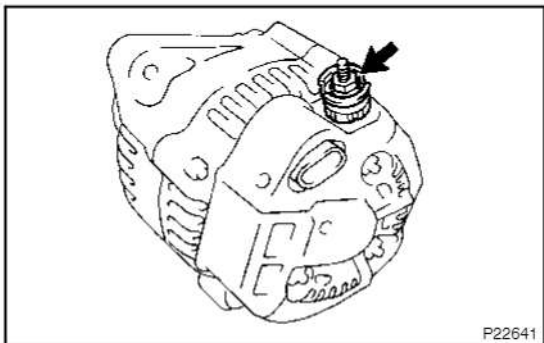

- (b) Install the terminal insulator with the nut.
Torque: 4.1 N·m (42 kgf·cm, 36 in·lbf)
8. **CHECK THAT ROTOR ROTATES SMOOTHLY**