

## ON-VEHICLE INSPECTION

### 1. CHECK BATTERY ELECTROLYTE LEVEL

Check the electrolyte quantity of each cell.

Maintenance-Free Battery:

If under the lower level, replace the battery (or add distilled water if possible), and check the charging system.

Except Maintenance-Free Battery:

If under the lower level, add distilled water.

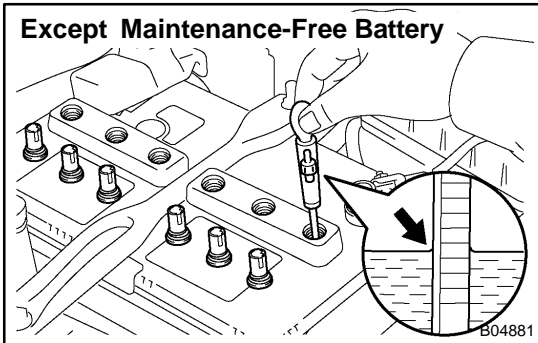

### 2. Except Maintenance-Free Battery: CHECK BATTERY SPECIFIC GRAVITY

Check the specific gravity of each cell.

**Standard specific gravity:**

**1.25 - 1.29 at 20°C (68°F)**

If the specific gravity is less than specification, charge the battery.

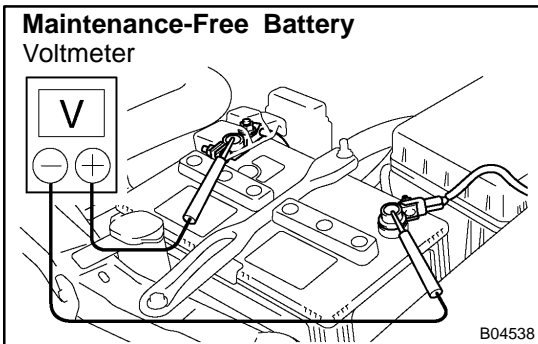

### 3. Maintenance-Free Battery: CHECK BATTERY VOLTAGE

(a) After having driven the vehicle and in the case that 20 minutes have not passed after having stopped the engine, turn the ignition switch ON and turn on the electrical system (headlight, blower motor, rear defogger etc.) for 60 seconds to remove the surface charge.

(b) Turn the ignition switch OFF and turn off the electrical systems.

(c) Measure the battery voltage between the negative (-) and positive (+) terminals of the battery.

**Standard voltage:**

**12.5 - 12.9 V at 20°C (68°F)**

If the voltage is less than specification, charge the battery.

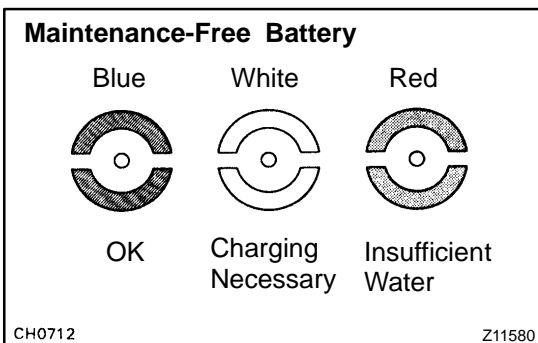

#### HINT:

Check the indicator as shown in the illustration.

### 4. CHECK BATTERY TERMINALS, FUSIBLE LINK AND FUSES

(a) Check that the battery terminals are not loose or corroded.

(b) Check the fusible link and fuses for continuity.

**5. INSPECT DRIVE BELT**

HINT:

A belt tensioner is used, so checking the belt tension is not necessary.

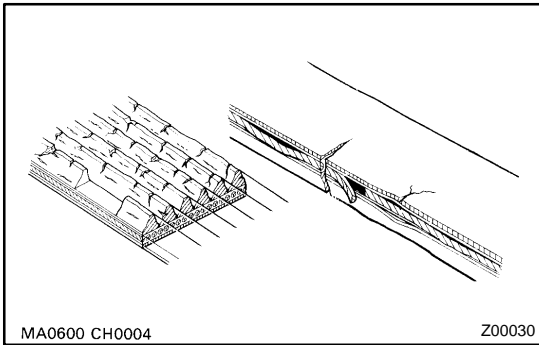

- (a) Visually check the drive belt for excessive wear, frayed cords etc.

If necessary, replace the drive belt.

HINT:

- ◆ Cracks on the rib side of a drive belt are considered acceptable. If the drive belt has chunks missing from the ribs, it should be replaced.
- ◆ The drive belt tension can be released by turning the belt tensioner counterclockwise. The pulley bolt for the belt tensioner has a left-hand thread.

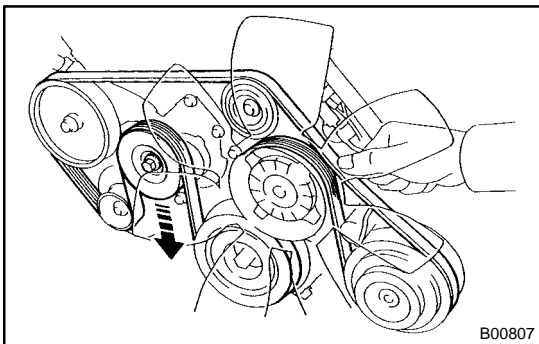

- (b) Check the belt tensioner operation.

- ◆ Check that the belt tensioner moves downward when the drive belt is pressed down at the points indicated in the illustration with approx. 98 N (10 kgf, 22.0 lbf) of force.
- ◆ Check the alignment of the belt tensioner pulley to make sure the drive belt has not slipped off the pulley.

If necessary, replace the belt tensioner.

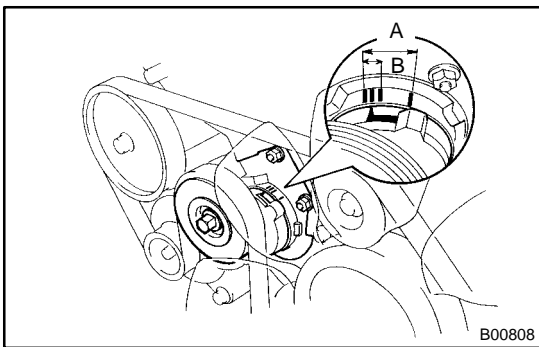

- ◆ Check that the arrow mark on the belt tensioner falls within area A of the scale.

If it is outside area A, replace the drive belt.

HINT:

- ◆ When a new belt is installed, it should lie within area B. If not, the drive belt is not correct.

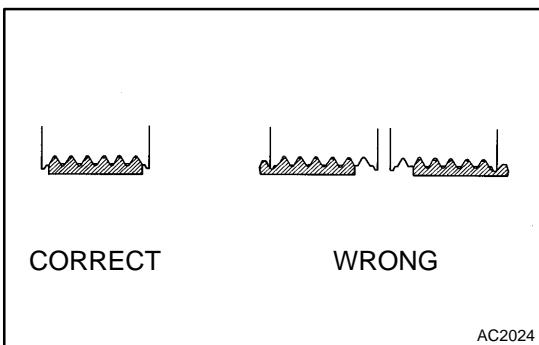

- ◆ After installing a belt, check that it fits properly in the ribbed grooves.
- ◆ Check by hand to confirm that the belt has not slipped out of the groove on the bottom of the pulley.

**6. REMOVE ENGINE UNDER COVER NO.1**

**7. VISUALLY CHECK GENERATOR WIRING AND LISTEN FOR ABNORMAL NOISES**

- (a) Check that the wiring is in good condition.
- (b) Check that there is no abnormal noise from the generator while the engine is running.

**8. CHECK CHARGE WARNING LIGHT CIRCUIT**

- (a) Warm up the engine and then turn it off.
  - (b) Switch off all accessories.
  - (c) Turn the ignition switch ON, and check that the charge warning light is lit.
  - (d) Start the engine, and check that the light goes off.
- If the light does not go off as specified, troubleshoot the charge light circuit.

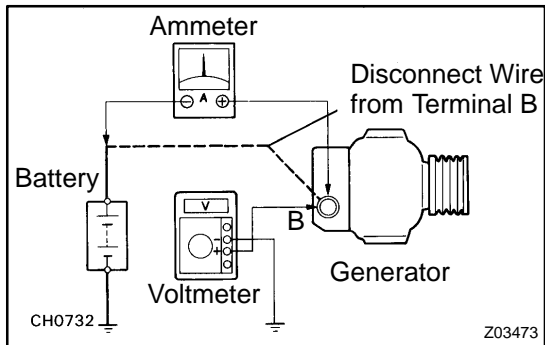
**9. INSPECT CHARGING CIRCUIT WITHOUT LOAD****HINT:**

If a battery/generator tester is available, connect the tester to the charging circuit as per manufacturer's instructions.

- (a) If a tester is not available, connect a voltmeter and ammeter to the charging circuit as follows:
  - ◆ Disconnect the wire from terminal B of the generator, and connect it to the negative (-) tester probe of the ammeter.
  - ◆ Connect the positive (+) tester probe of the ammeter to terminal B of the generator.
  - ◆ Connect the positive (+) tester probe of the voltmeter to terminal B of the generator.
  - ◆ Ground the negative (-) tester probe of the voltmeter.
- (b) Check the charging circuit as follows:
 

With the engine running from idling to 2,000 rpm, check the reading on the ammeter and voltmeter.

**Standard amperage:****10 A or less****Standard voltage:****13.2 - 14.8 V**

If the value is not specified, check the generator.

**10. INSPECT CHARGING CIRCUIT WITH LOAD**

- (a) With the engine running at 2,000 rpm, turn on the high beam headlights and place the heater blower switch at HI.
- (b) Check the reading on the ammeter.

**Standard amperage:****30 A or more**

If the ammeter reading is less than the standard amperage, repair the generator.

**HINT:**

If the battery is fully charged, the indication will sometimes be less than standard amperage.

**11. REINSTALL ENGINE UNDER COVER NO.1**

# CHARGING SYSTEM

CH06F-01

## PRECAUTION

- ◆ Check that the battery cables are connected to the correct terminals.
- ◆ Disconnect the battery cables when the battery is given a quick charge.
- ◆ Do not perform tests with a high voltage insulation resistance tester.
- ◆ Never disconnect the battery while the engine is running.

# GENERATOR COMPONENTS

CH06H-09

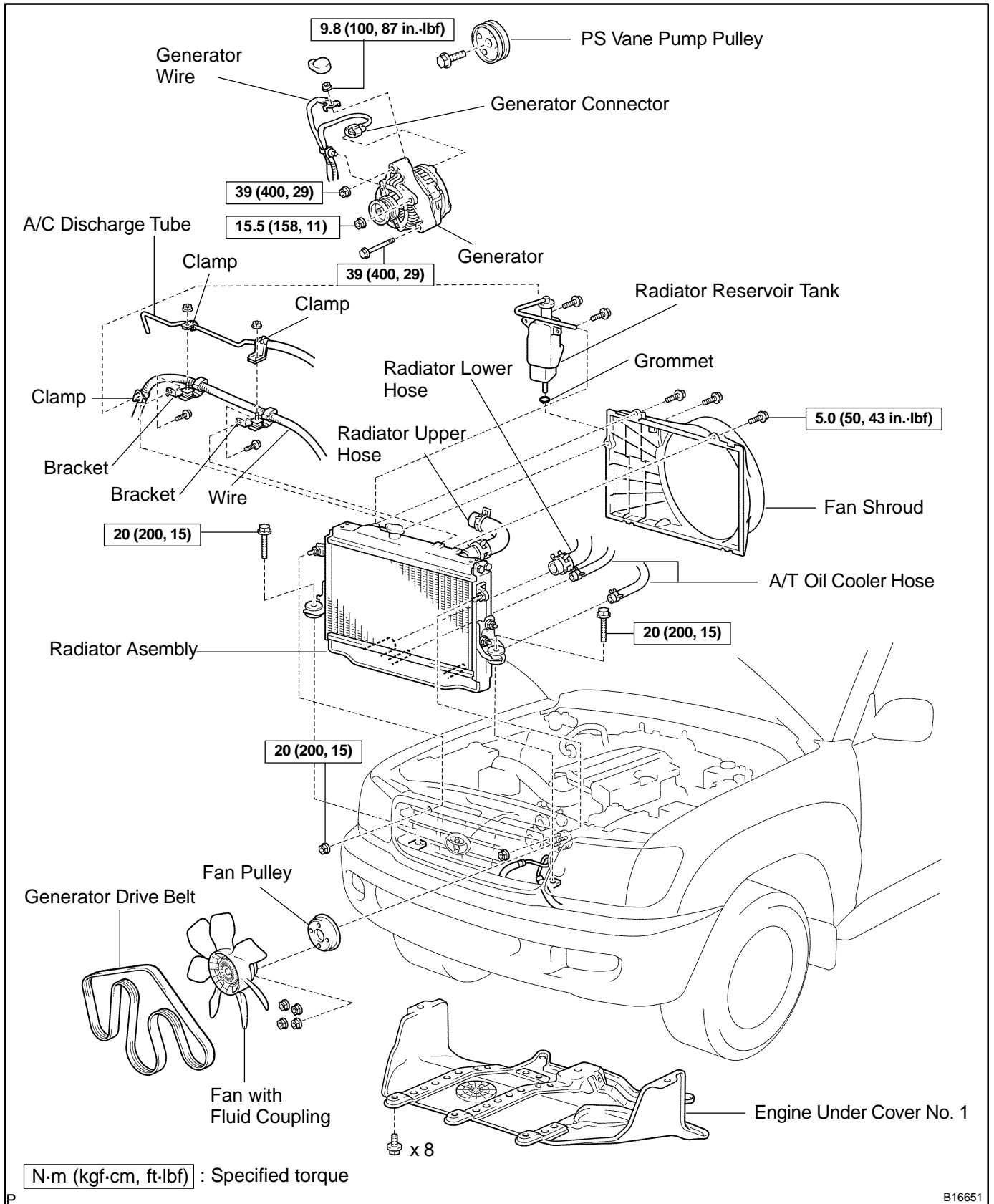

B16651

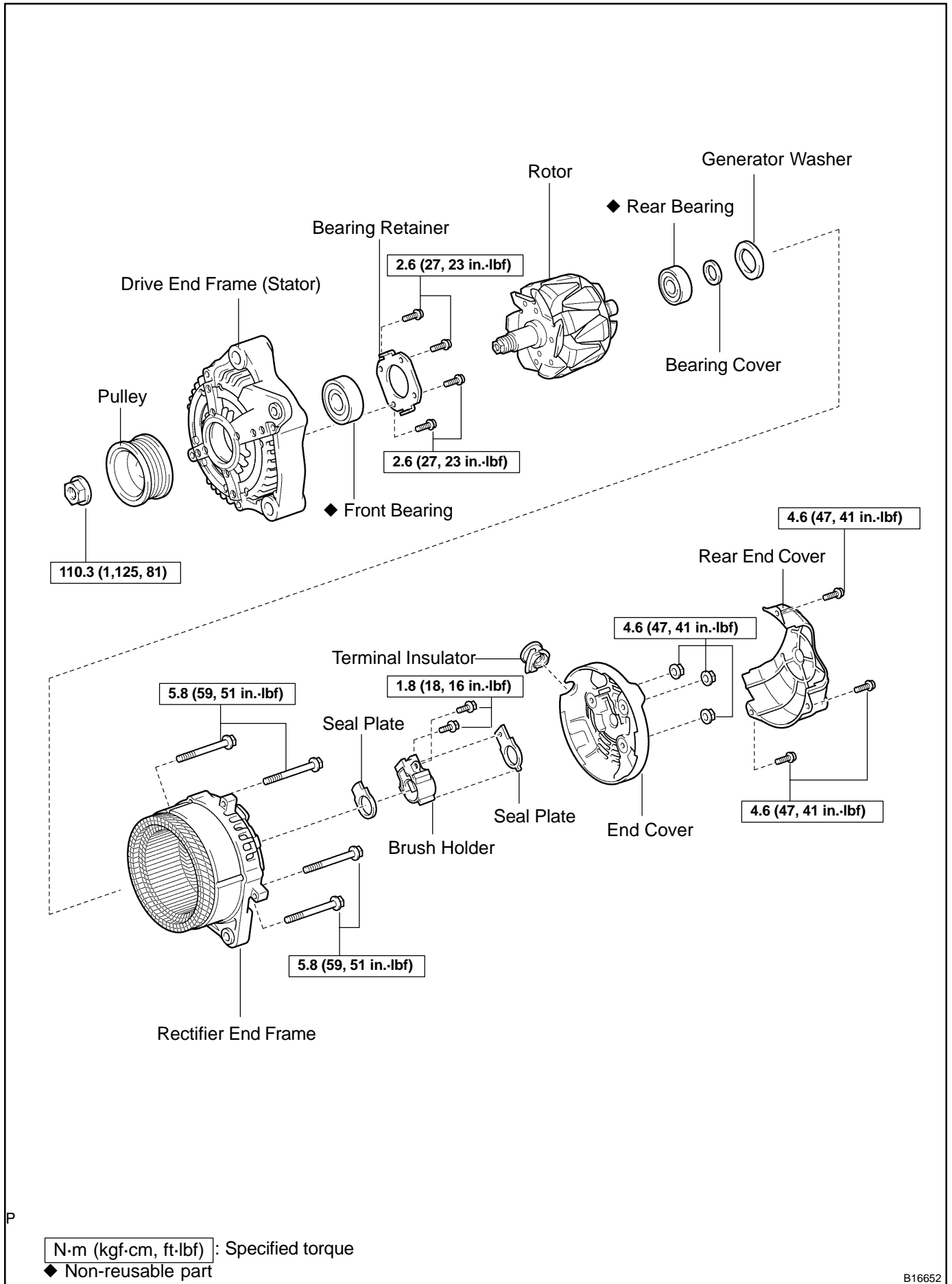

B16652

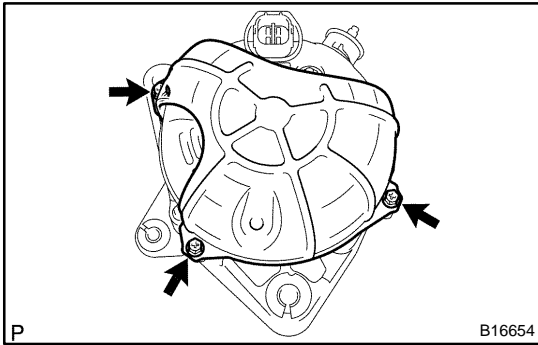

## DISASSEMBLY

### 1. REMOVE REAR END COVER

- (a) Remove the 3 screws and rear end cover.

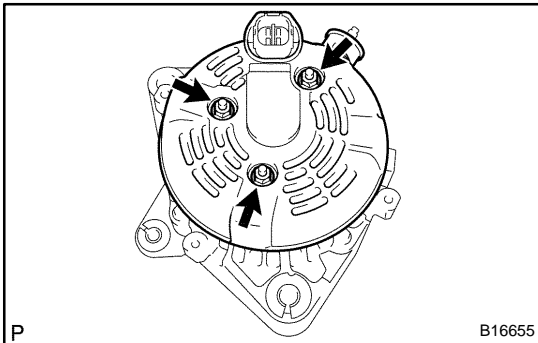

### 2. REMOVE END COVER

- (a) Remove the 3 nuts and end cover.  
(b) Remove the terminal insulator.

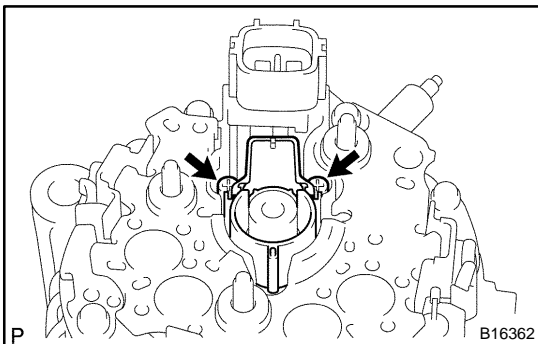

### 3. REMOVE BRUSH HOLDER

- (a) Remove the rear seal plate from the brush holder.  
(b) Remove the 2 screws and brush holder.  
(c) Remove the front seal plate from the coil assembly.

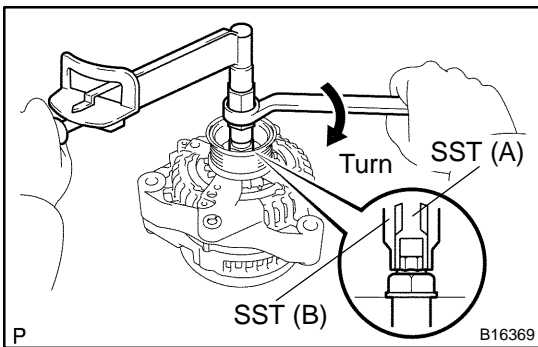

### 4. REMOVE PULLEY

- (a) Hold SST (A) with a torque wrench, and tighten SST (B) clockwise to the specified torque.

SST 09820-6301 1

**Torque: 39 N·m (400 kgf·cm, 29 ft·lbf)**

- (b) Check that SST (A) is secured to the rotor shaft.

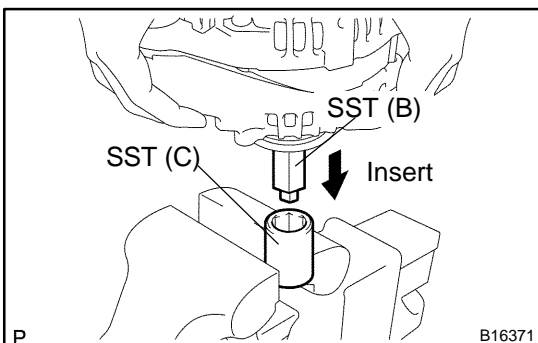

- (c) Mount SST (C) in a vise.

- (d) Insert SST (B) into SST (C), and attach the pulley nut to SST (C).

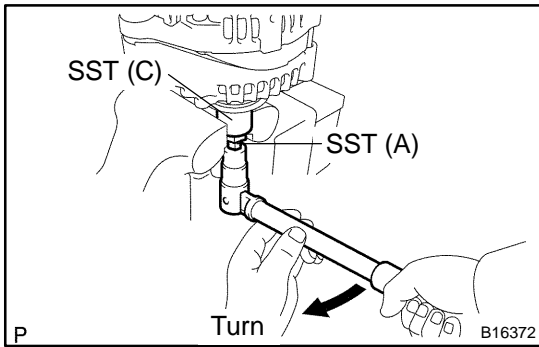

(e) To loosen the pulley nut, turn SST (A) in the direction shown in the illustration.

**NOTICE:**

**To prevent damage to the rotor shaft, do not loosen the pulley nut more than one-half of a turn.**

(f) Remove the generator from SST (C).

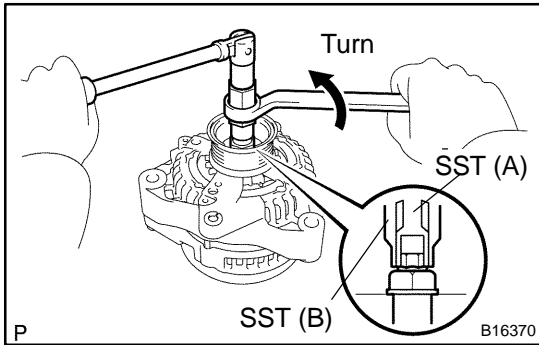

(g) Turn SST (B), and remove SST (A and B).

(h) Remove the pulley nut and pulley.

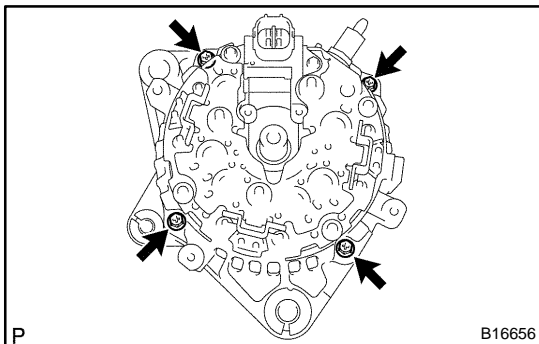

**5. REMOVE COIL ASSEMBLY**

(a) Remove the 4 bolts.

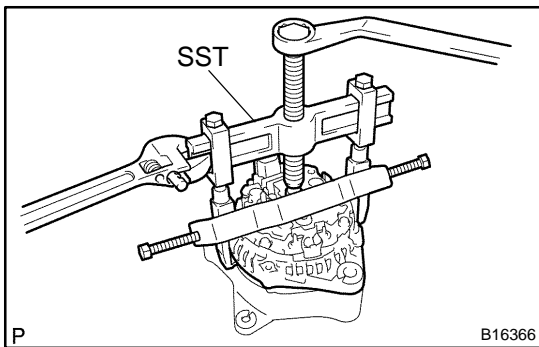

(b) Using SST, remove the coil assembly.

SST 09950-4001 1 (09951-04020, 09952-04010, 09953-04020, 09954-04010, 09955-04071, 09958-0401 1)

(c) Remove the generator washer.

**6. REMOVE ROTOR FROM DRIVE END FRAME**



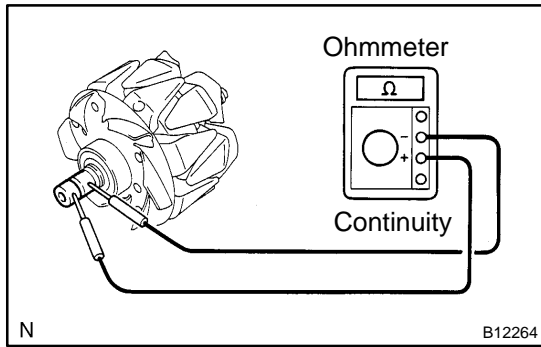

## INSPECTION

### 1. INSPECT ROTOR

- (a) Check the rotor for open circuit.

Using an ohmmeter, check that there is continuity between the slip rings.

**Standard resistance: 2.3 - 2.7  $\Omega$  at 20°C (68°F)**

If there is no continuity, replace the rotor.

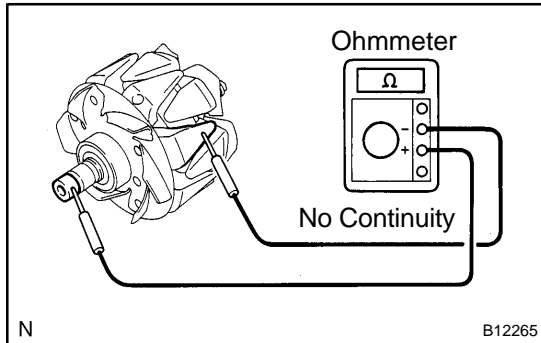

- (b) Check the rotor for ground.

Using an ohmmeter, check that there is no continuity between the slip ring and rotor.

If there is continuity, replace the rotor.

- (c) Check that the slip rings are not rough or scored.

If rough or scored, replace the rotor.

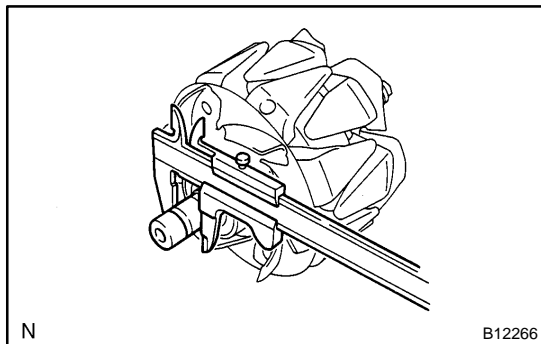

- (d) Using vernier calipers, measure the slip ring diameter.

**Standard diameter: 14.2 - 14.4 mm (0.559 - 0.567 in.)**

**Minimum diameter: 14.0 mm (0.551 in.)**

If the diameter is less than minimum, replace the rotor.

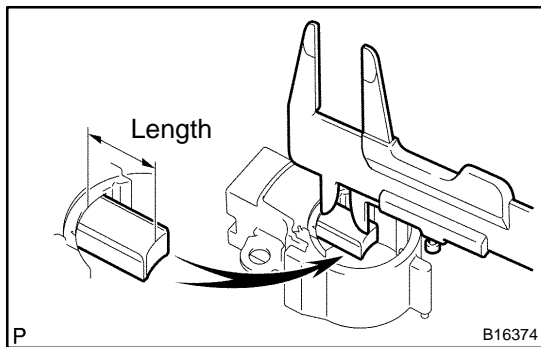

### 2. INSPECT BRUSHES

Using vernier caliper, measure the exposed brush length.

**Standard exposed length: 10.5 mm (0.413 in.)**

**Minimum exposed length: 4.5 mm (0.177 in.)**

If the exposed length is less than minimum, replace the brushes and brush holder assembly.

### 3. INSPECT BEARING

Check the bearing is not rough or worn.

If necessary, replace the bearing (See page [CH-1 1](#)).

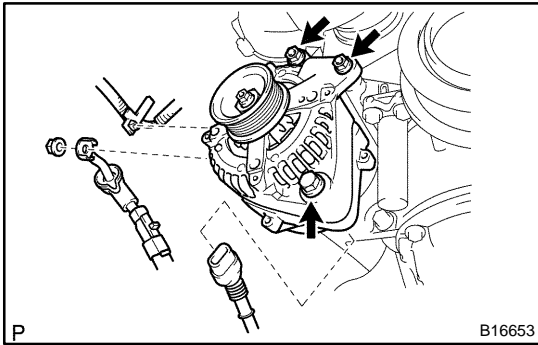

## INSTALLATION

### 1. INSTALL GENERATOR

- (a) Install the generator with the bolt and 2 nuts.

**Torque:**

**Bolt: 39 N·m (400 kgf·cm, 29 ft·lbf)**

**Nut 10 mm: 39 N·m (400 kgf·cm, 29 ft·lbf)**

**Nut 8 mm: 15.5 N·m (158 kgf·cm, 11 ft·lbf)**

- (b) Connect the generator connector.  
 (c) Connect the generator wire with the nut.  
**Torque: 9.8 N·m (100 kgf·cm, 87 in·lbf)**  
 (d) Install the terminal cap.  
 (e) Install the wire clamp to the cord clip on the generator.

### 2. INSTALL PS VANE PUMP PULLEY

(See page [SR-47](#) )

### 3. INSTALL RADIATOR ASSEMBLY

(See page [CO-19](#) )

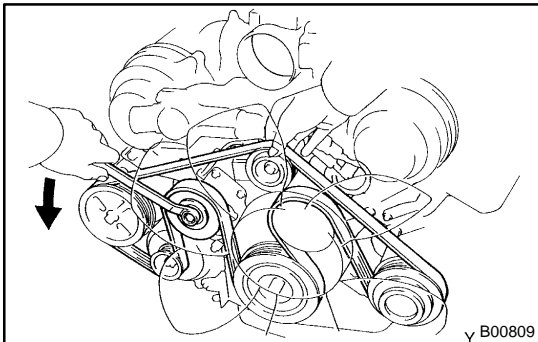

### 4. INSTALL GENERATOR DRIVE BELT

Install the belt by turning the belt tensioner counterclockwise.

**HINT:**

The pulley bolt for the belt tensioner has a left - hand thread.

### 5. FULL ENGINE COOLANT

### 6. START ENGINE AND CHECK FOR LEAKS

### 7. RECHECK ENGINE COOLANT LEVEL

### 8. PERFORM ON-VEHICLE INSPECTION

(See page [CH-2](#) )

### 9. INSTALL ENGINE UNDER COVER NO.1

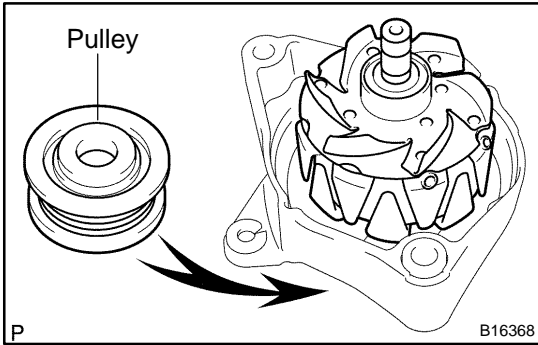

## REASSEMBLY

### 1. INSTALL ROTOR TO DRIVE END FRAME

- (a) Place the drive end frame on the pulley.
- (b) Install the rotor to the drive end frame.

### 2. INSTALL COIL ASSEMBLY

- (a) Place the generator washer on the rotor.

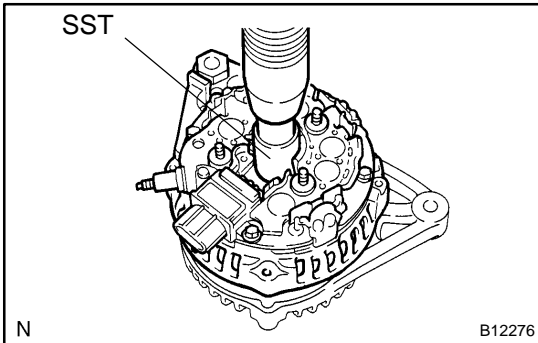

- (b) Using SST and a press, slowly press in the coil assembly.  
SST 09285-76010

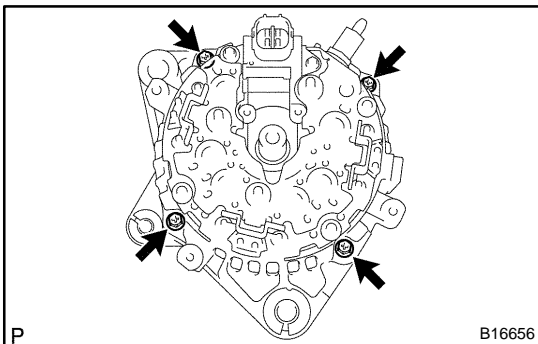

- (c) Install the coil assembly with the 4 bolts.  
**Torque: 5.8 N·m (59 kgf·cm, 51 in.-lbf)**

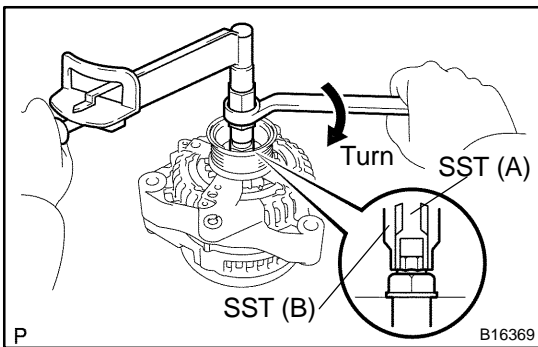

### 3. INSTALL PULLEY

- (a) Install the pulley to the rotor shaft by tightening the pulley nut by hand.

- (b) Hold SST (A) with a torque wrench, and tighten SST (B) clockwise to the specified torque.

SST 09820-6301 1

**Torque: 39 N·m (400 kgf·cm, 29 ft·lbf)**

- (c) Check that SST (A) is secured to the pulley shaft.

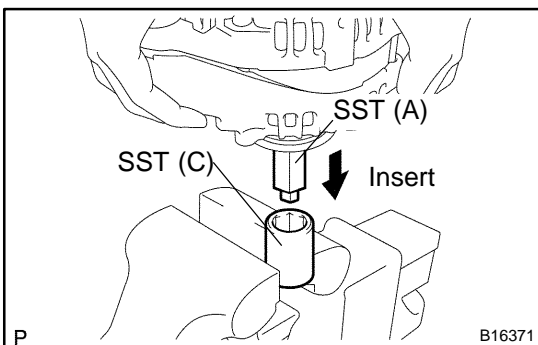

- (d) Mount SST (C) in a vise.

- (e) Insert SST (B) into SST (C), and attach the pulley nut to SST (C).

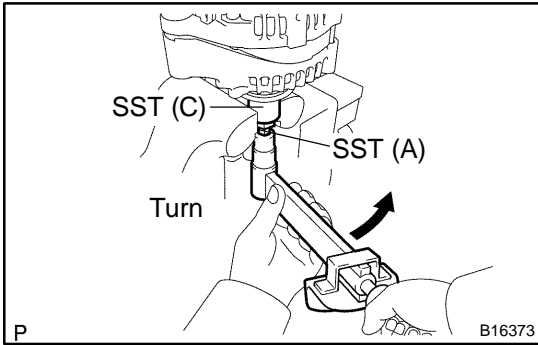

- (f) To torque the pulley nut, turn SST (A) in the direction shown in the illustration.  
**Torque: 110.3 N·m (1,125 kgf·cm, 81 ft·lbf)**
- (g) Remove the generator from SST (C).

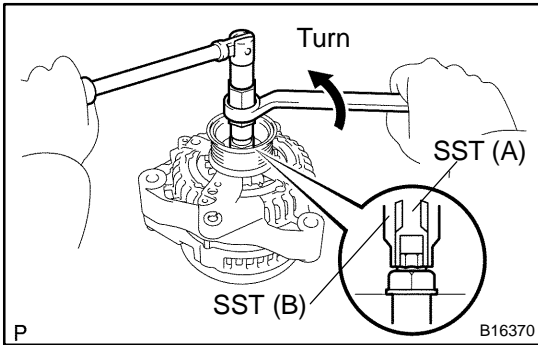

- (h) Turn SST (B), and remove SST (A and B).

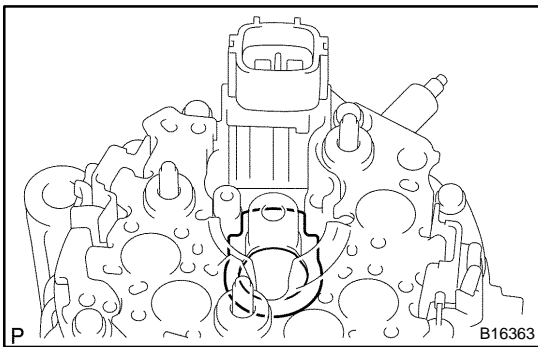

**4. INSTALL BRUSH HOLDER**

- (a) Place the front seal plate on the coil assembly.

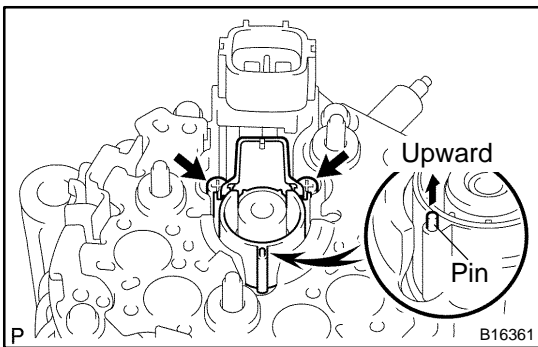

- (b) Place the brush holder on the coil assembly with the pin facing upward.

**NOTICE:**

**Be careful of the holder installation direction.**

- (c) Install the 2 screws.  
**Torque: 1.8 N·m (18 kgf·cm, 16 in.-lbf)**

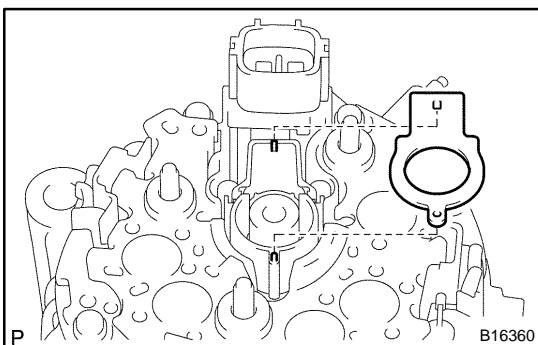

- (d) Align the pins of the brush holder with the holes of the rear seal plate, and install the rear seal plate.

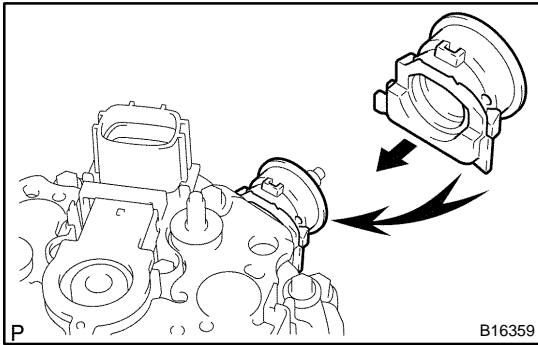

### 5. INSTALL END COVER

(a) Install the terminal insulator.

**NOTICE:** Be careful of the terminal insulator installation direction.

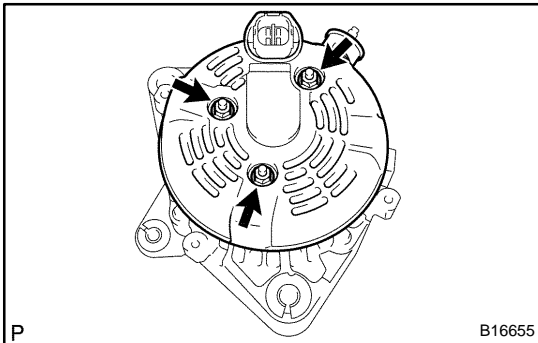

(b) Install the end cover with the 3 nuts.

**Torque: 4.6 N·m (47 kgf·cm, 41 in.-lbf)**

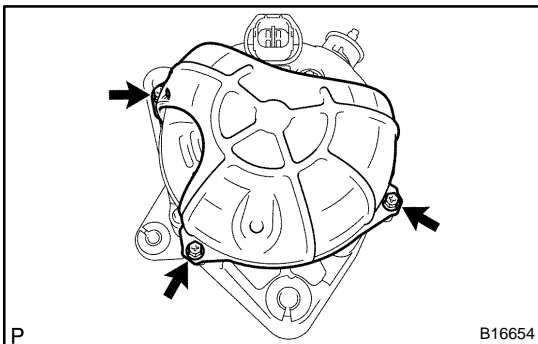

### 6. INSTALL REAR END COVER

Install the rear end cover with the 3 screws.

**Torque: 4.6 N·m (47 kgf·cm, 41 in.-lbf)**

### 7. CHECK THAT ROTOR ROTATES SMOOTHLY

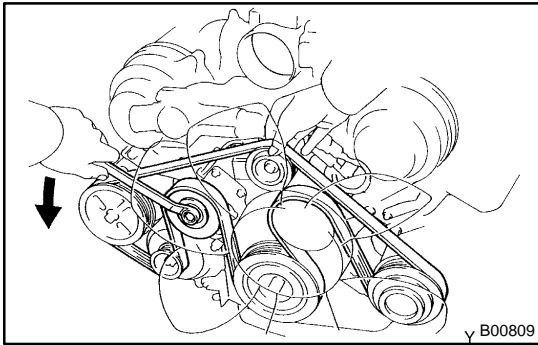

## REMOVAL

1. **DRAIN ENGINE COOLANT**  
(See page [CO-2](#))

2. **REMOVE GENERATOR DRIVE BELT**

Loosen the belt tension by turning the belt tensioner counter-clockwise, and remove the drive belt.

HINT:

The pulley bolt for the belt tensioner has a left - hand thread.

3. **REMOVE ENGINE UNDER COVER NO.1**

4. **REMOVE RADIATOR ASSEMBLY**  
(See page [CO-17](#))

5. **REMOVE PS VANE PUMP PULLEY**  
(See page [SR-40](#))

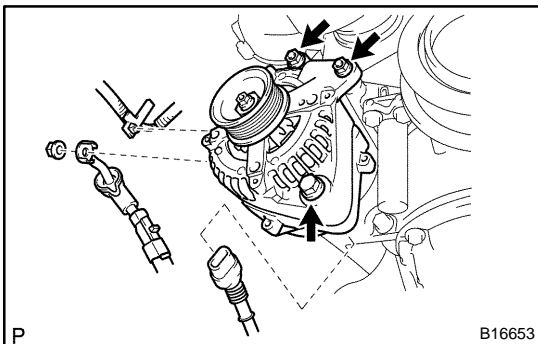

6. **REMOVE GENERATOR**

- (a) Disconnect the generator connector.
- (b) Remove the rubber cap and nut, and disconnect the generator wire.
- (c) Disconnect the generator wire clamp from the cord clip on the generator.
- (d) Remove the bolt, 2 nuts and generator.

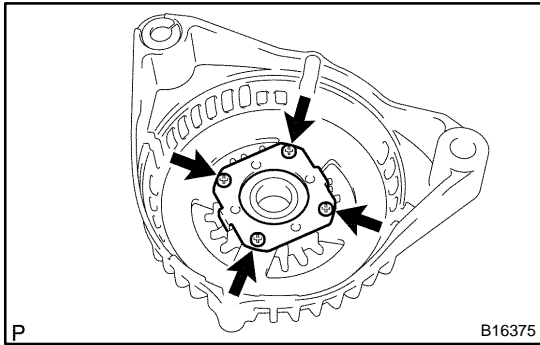

## REPLACEMENT

### 1. REPLACE FRONT BEARING

- (a) Remove the 4 screws, bearing retainer and bearing.

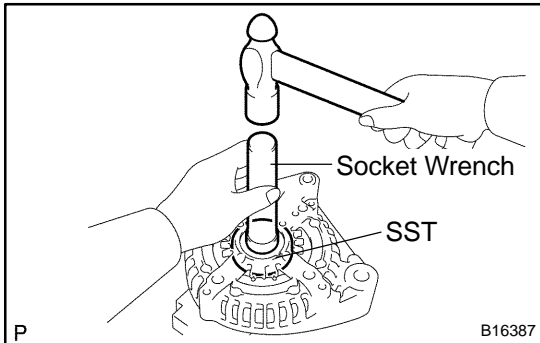

- (b) Using SST and a hammer, tap out the bearing.  
 SST 09950-60010 (09951-00250), 09950-70010 (09951-07100)

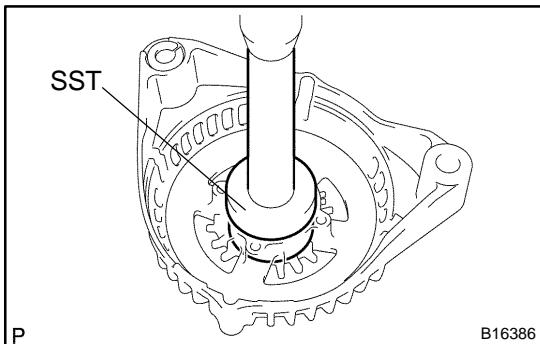

- (c) Using SST and a press, press in a new bearing.  
 SST 09950-60010 (09951-00470), 09950-70010 (09951-07100)

- (d) Install the bearing retainer with the 4 screws.  
**Torque: 2.6 N·m (27 kgf·cm, 23 in.-lbf)**

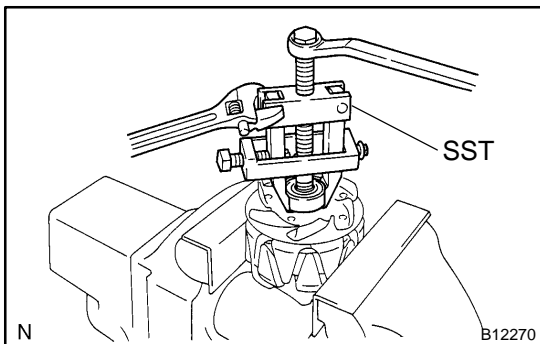

### 2. REPLACE REAR BEARING

- (a) Using SST, remove the bearing cover (outside) and bearing.  
 SST 09820-00021

**NOTICE:**  
**Be careful not to damage the fan.**

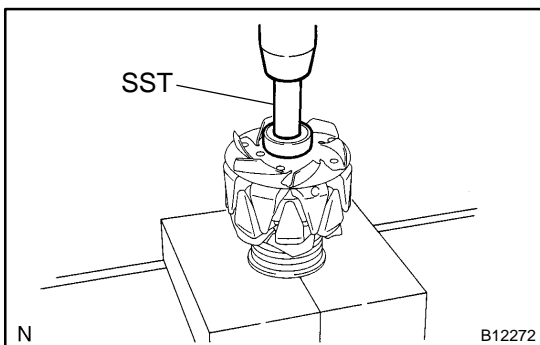

- (b) Using SST and a press, press in a new bearing.  
 SST 09820-00031

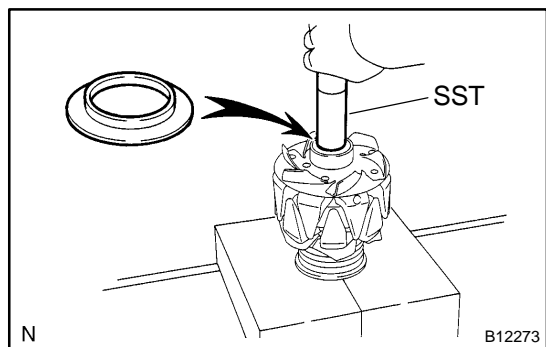

- (c) Using SST, push in the bearing cover (outside).  
SST 09285-76010