

COIL SPRING AND REAR SHOCK ABSORBER COMPONENTS

SA169-02

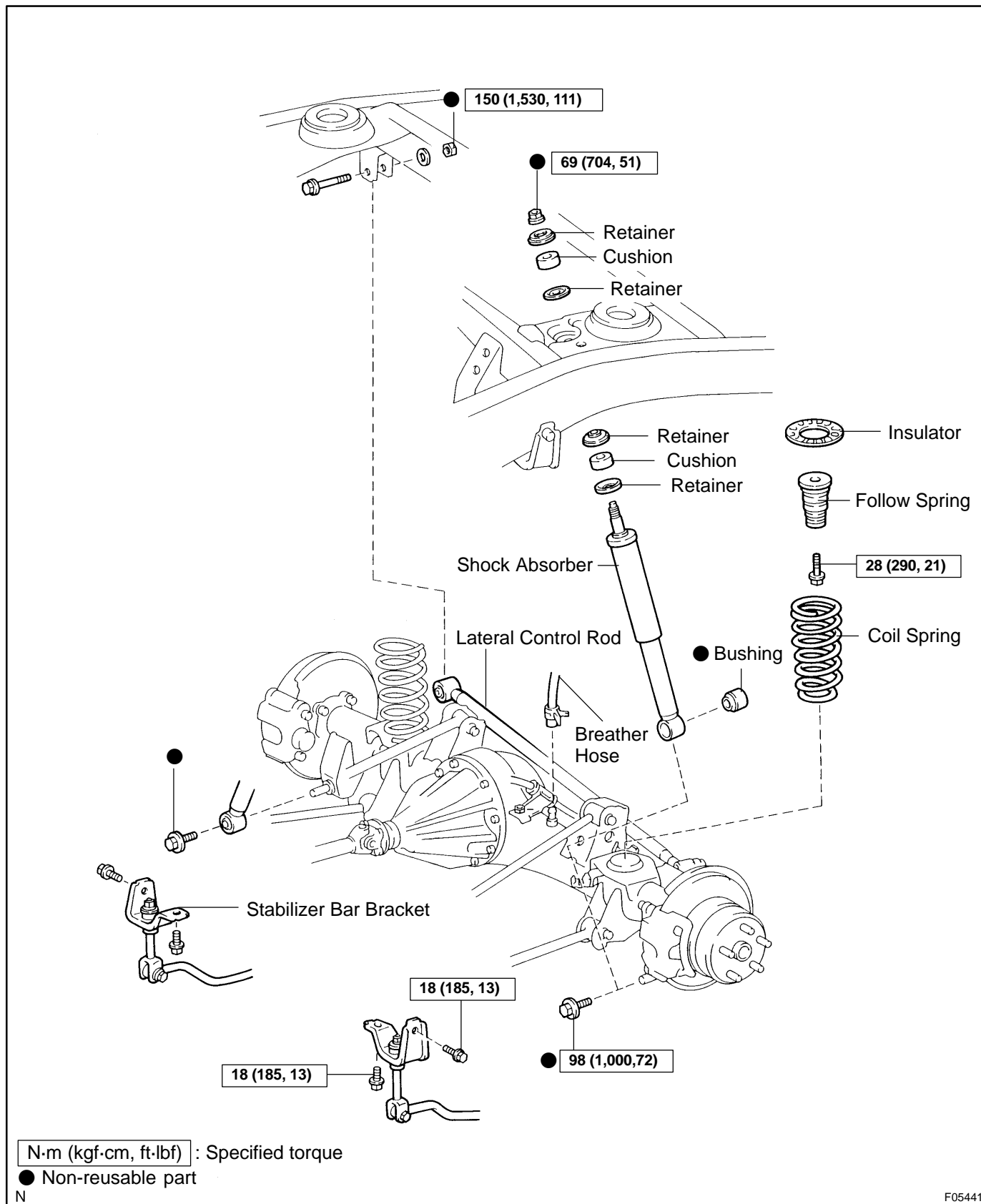

F05441

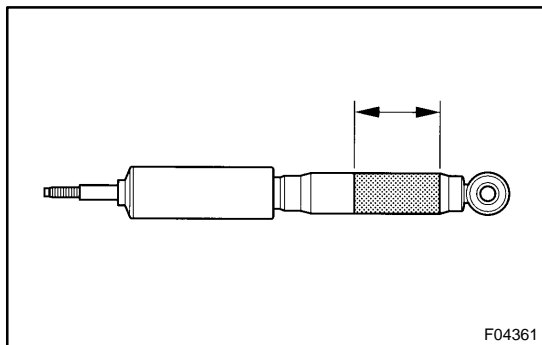

DISPOSAL

DISCARD SHOCK ABSORBER

Before discarding the shock absorber, drill a hole of 2 - 3 mm (0.079 - 0.118 in.) in diameter at the location shown in the illustration to discharge the gas inside.

NOTICE:

- When drilling, chips may fly out, work carefully.
- The gas is colorless, odorless and non-poisonous.

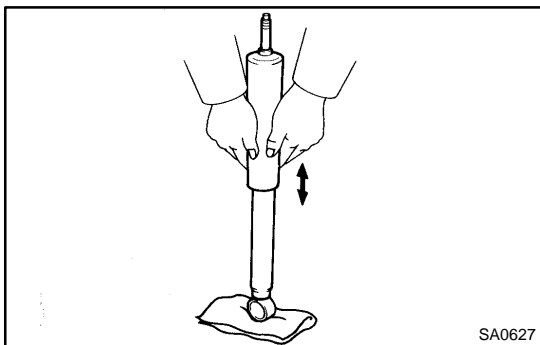

INSPECTION

INSPECT SHOCK ABSORBER

Compress and extend the shock absorber rod and check that there is no abnormal resistance or unusual operation sounds. If there is any abnormality, replace the shock absorber with a new one.

NOTICE:

When disposing the shock absorber, see **DISPOSAL** on page [SA-175](#) .

INSTALLATION

Installation is in the reverse order of removal (See page [SA-172](#)).

REMOVAL

1. REMOVE REAR WHEELS
Torque: 131 N·m (1,340 kgf·cm, 97 ft·lbf)
2. SUPPORT REAR AXLE HOUSING WITH JACK

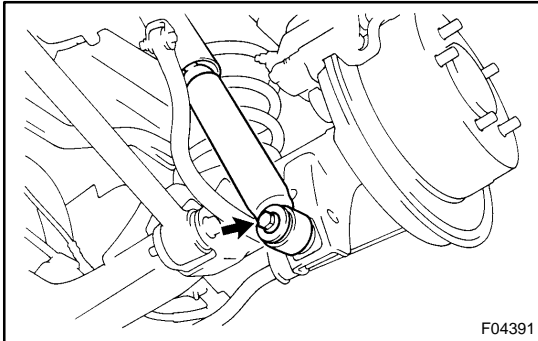

3. REMOVE SHOCK ABSORBER

- (a) Remove the bolt and disconnect the shock absorber from the axle housing.

Torque: 98 N·m (1,000 kgf·cm, 72 ft·lbf)

- (b) Employ the same manner described above to the other side.

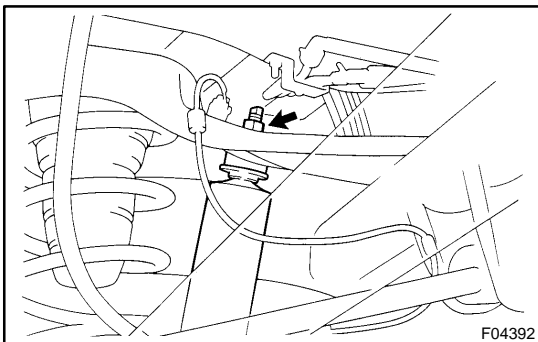

- (c) While holding the piston rod, remove the nut, 2 retainers, cushion and shock absorber.

Torque: 69 N·m (704 kgf·cm, 51 ft·lbf)

- (d) Remove the 2 retainers and cushion from the shock absorber.

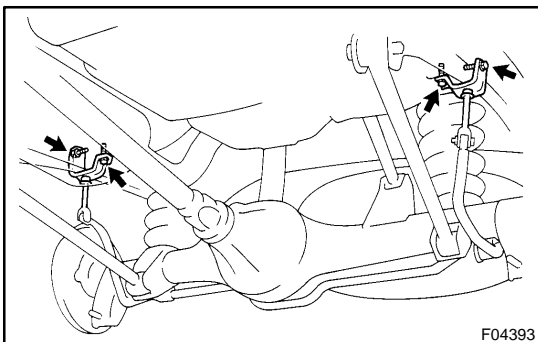

4. DISCONNECT LH AND RH STABILIZER BAR BRACKETS

Remove the 4 bolts and disconnect the LH and RH stabilizer bar brackets.

Torque: 18 N·m (185 kgf·cm, 13 ft·lbf)

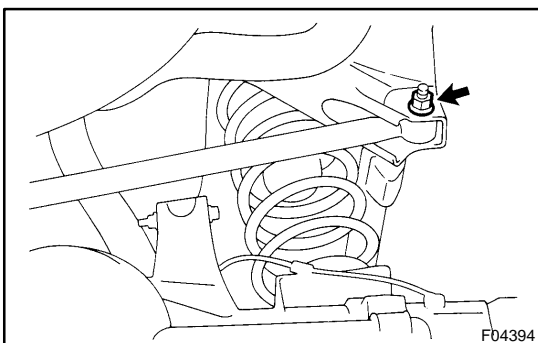

5. DISCONNECT LATERAL CONTROL ROD

Remove the nut, washer, bolt and disconnect the lateral control rod.

Torque: 150 N·m (1,530 kgf·cm, 111 ft·lbf)

HINT:

At the time of installation, after stabilizing the suspension, torque the nut and bolt.

6. DISCONNECT BREATHER HOSE

7. REMOVE COIL SPRING

(a) Begin to lower the axle housing.

NOTICE:

Be careful not to snap the brake line and parking brake cable.

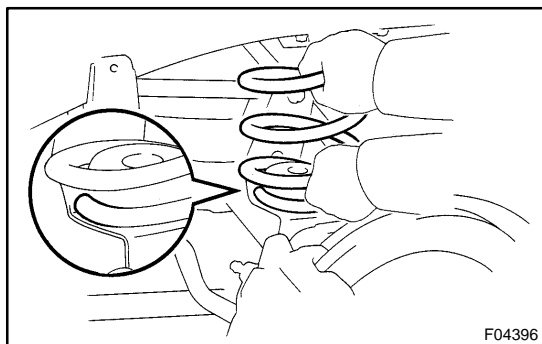

(b) While lowering the axle housing, remove the coil spring and insulator.

HINT:

At the time of installation, please refer to the following items.

- Check that the coil spring end is installed correctly.
- If the coil spring end is not in the correct position, reinstall the coil spring.

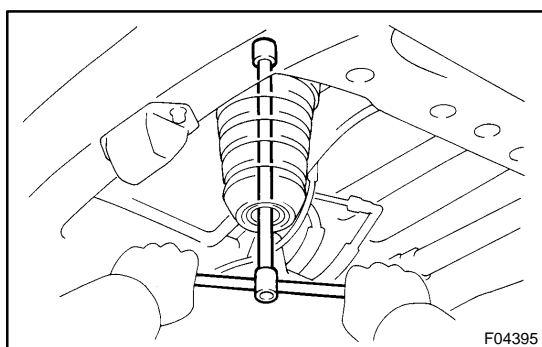

(c) Remove the bolt and follow spring from the frame.

Torque: 28 N·m (290 kgf·cm, 21 ft·lbf)

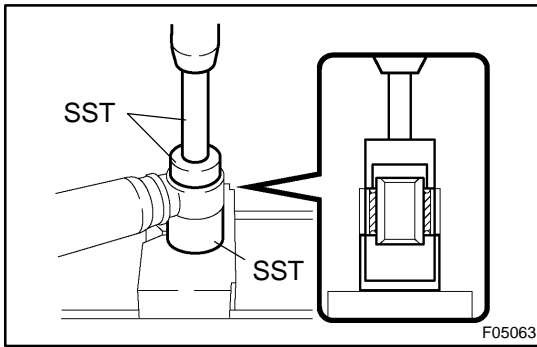

REPLACEMENT

1. REMOVE BUSHING

Using SST and a press, remove the bushing.

SST 09710-14013 (09710-00061),
09710-28012 (09710-07031),
09950-70010 (09951-07100)

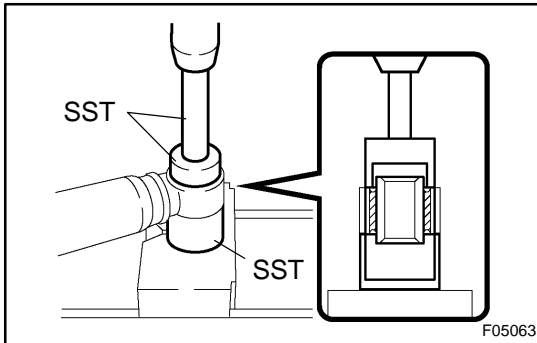

2. INSTALL BUSHING

Using SST and a press, install a new bushing.

SST 09710-14013 (09710-00061),
09710-28012 (09710-07031),
09950-70010 (09951-07100)

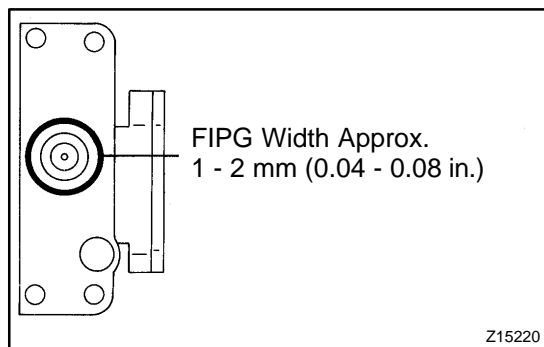

INSTALLATION

1. INSTALL ACTUATOR

- (a) Clean contacting surfaces of any FIPG material using gasoline or alcohol.
- (b) Apply FIPG to the actuator.

FIPG:

Part No. 08826-00090, THREE BOND 1281 or equivalent

HINT:

Install the actuator within 10 minutes after applying FIPG.

- (c) Install the actuator to the differential and match the shaft with the shaft fork hole.
- (d) Clean the threads of the set bolt and shaft fork with the white gasoline.

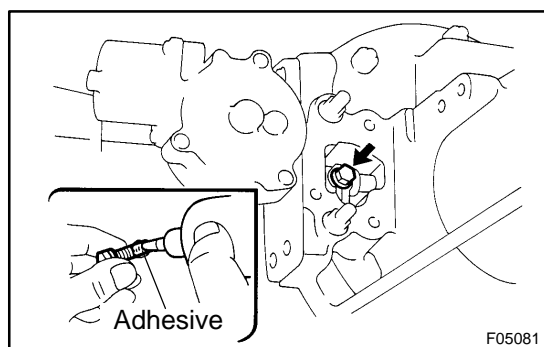

- (e) Coat the threads of the set bolt with adhesive.

Adhesive:

Part No. 08833-00070, THREE BOND 1324 or equivalent

- (f) Tighten the shift fork set bolt.
- Torque: 20 N·m (200 kgf·cm, 15 ft·lbf)**

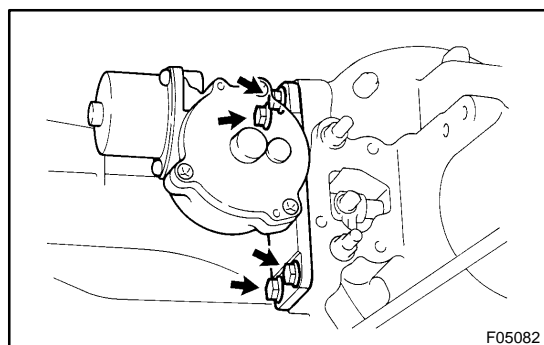

- (g) Tighten the 4 bolts uniformly, a little at a time.
- Torque: 24 N·m (240 kgf·cm, 18 ft·lbf)**

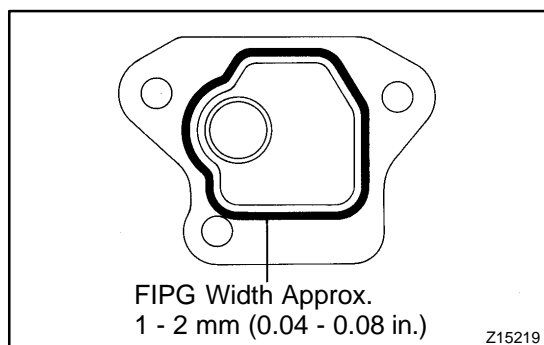

2. INSTALL COVER

- (a) Clean the contacting surfaces of any FIPG material using gasoline or alcohol.
- (b) Apply FIPG to the cover.

FIPG:

Part No. 08826-00090, THREE BOND 1281 or equivalent

HINT:

Install the cover within 10 minutes after applying FIPG.

- (c) Install the cover with the 3 bolts.

Torque: 18 N·m (185 kgf-cm, 13 ft-lbf)

3. INSTALL REAR DIFF. LOCK POSITION SWITCH

Install the diff. lock position switch with a new gasket.

Torque: 40 N·m (410 kgf-cm, 30 ft-lbf)

4. CONNECT CONNECTORS AND TUBE

HINT:

- The depth of the insertion of the bleeder tube into the hose is approx. 15 mm (0.59 in.).
- Take care that the water or the equivalent will not adhere to the connectors and hose.

5. INSTALL NO. 2 ACTUATOR PROTECTOR

Install the No. 2 actuator protector with the 2 nuts.

Torque: 36 N·m (367 kgf-cm, 27 ft-lbf)

6. INSTALL NO. 1 ACTUATOR PROTECTOR

Install the No. 1 actuator protector with the nut and bolt.

Torque: 15 N·m (150 kgf-cm, 11 ft-lbf)

7. CANCEL REAR DIFFERENTIAL LOCK POSITION

- (a) Connect the cable to the negative terminal of the battery.
- (b) Turn the ignition switch to the ON position.
- (c) Turn the differential lock control switch to the OFF position and cancel the differential lock.
- (d) Shift the transfer shift lever to H position.

LOCATION

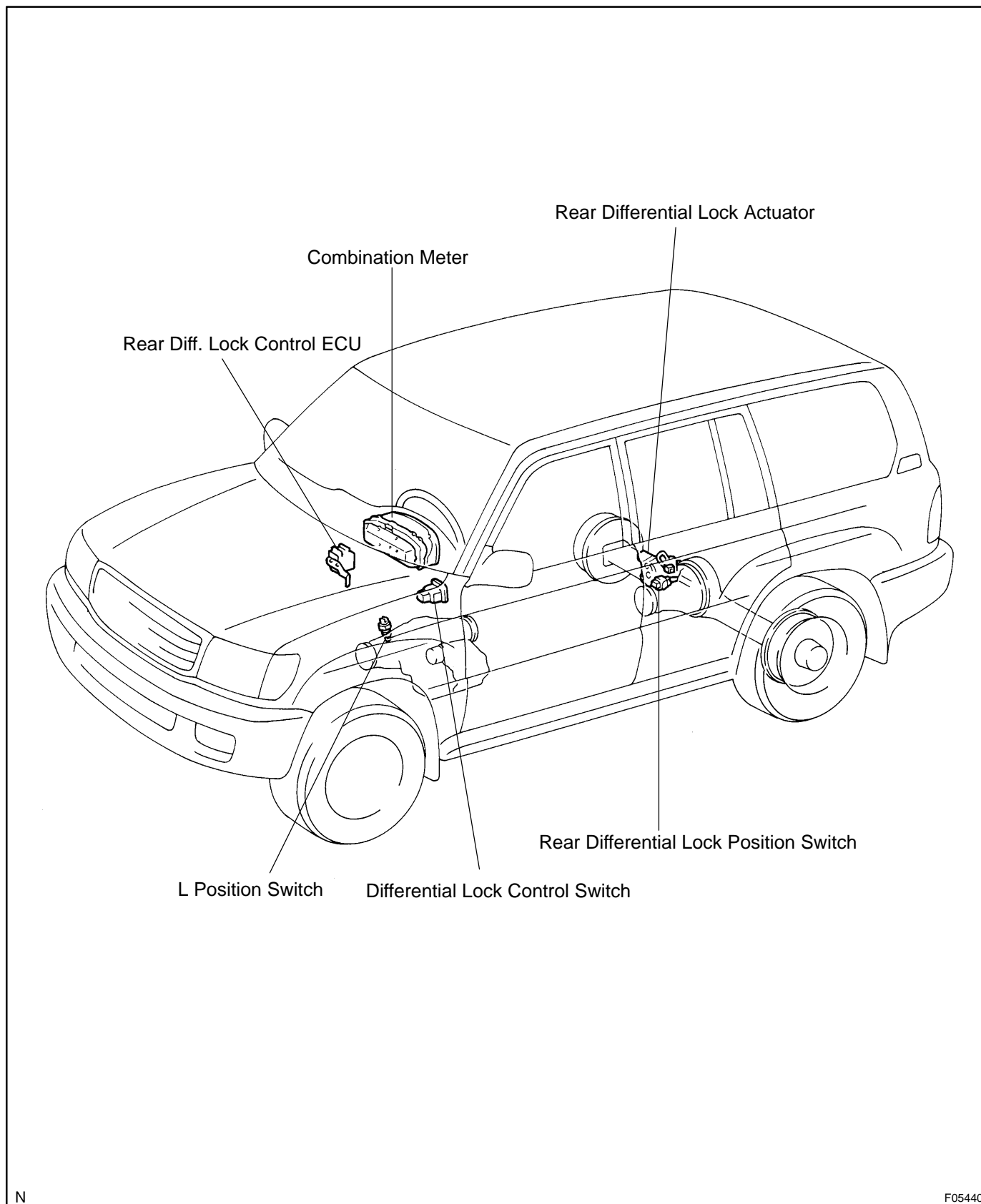

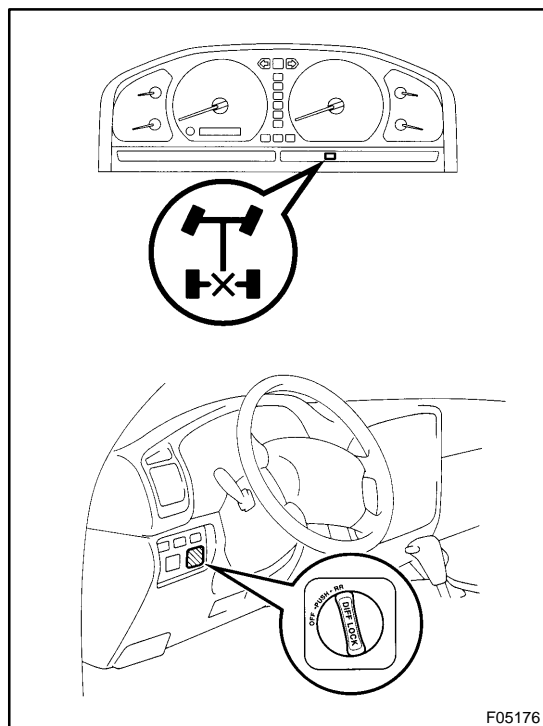

DIFFERENTIAL LOCK SYSTEM ON-VEHICLE INSPECTION

SA165-06

1. INSPECT DIFFERENTIAL LOCK SYSTEM

- (a) Inspect the indicator light.
Check that the indicator light lights up for approx. 1 second when the ignition switch is turned ON.
- (b) Inspect the differential lock operation.
 - (1) Jack up the vehicle then start the engine.
 - (2) Shift the transfer shift lever to L position.
 - (3) When the diff. lock control switch is set to the RR position, the indicator light is turned on. Differential lock is applied to the rear wheel at this time.

HINT:

If the gears of the differential lock system are not meshed, the indicator light remains blinking, so rotate the tires to mesh the gear.

- (4) When the diff. lock control switch is at the OFF position, the indicator light goes off. Differential lock is released for the rear wheel at this time.

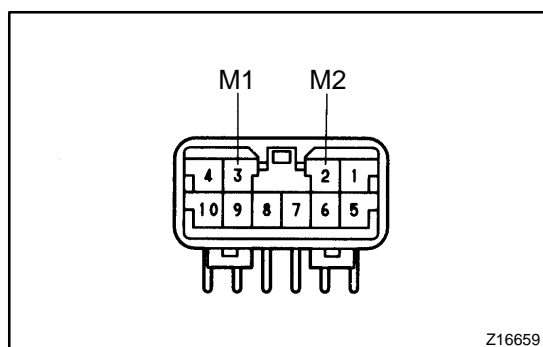

- (5) Check the voltage between the terminals of the rear diff. lock control ECU when switching the diff. lock control switch with the speedometer, registering approx. 8 km/h (5 mph) or more.

Switch position	Terminal	Specified value
ON	M1 - M2	0.5 V or less (No change)

- (6) Return the diff. lock control switch to OFF.
- (7) Stop the engine and lower the vehicle.

2. INSPECT DIFF. LOCK SYSTEM CIRCUIT

- (a) Inspect the battery positive voltage.
Battery positive voltage: 10 - 14 V

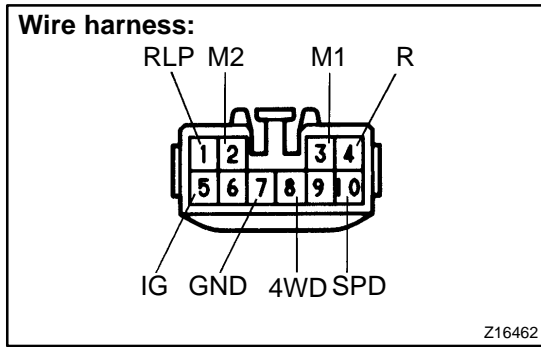

- (b) Inspect the system circuit with the connector disconnected.
 Disconnect the connector from the rear diff. lock control ECU and inspect the connector on the wire harness side, as shown in the table.

Symbols (Terminals No.)	Trouble part	Condition	Specified value
M1 - M2	RR Diff. Lock Actuator	-	Less than 100 Ω
GND - Body ground	Body ground	-	Continuity
SPD - Body ground	Speed sensor	Vehicle moves slowly	1 pulse each 40 cm (15.75 in.)
IG - Body ground	DIFF Fuse	Ignition switch ON	10 - 14 V
RLP - Body ground	Rear Diff. Lock Indicator Switch	Ignition switch ON with indicator light ON	About 0 V
		Ignition switch ON with indicator light OFF	10 - 14 V
4WD - Body ground	L position Switch	Ignition switch ON with T/F shift lever except L	About 0 V
		Ignition switch ON with T/F shift lever L	10 - 14 V
R - Body ground	Differential Lock Control Switch	Ignition switch ON with differential lock control switch RR	10 - 14 V
		Ignition switch ON with differential lock control switch OFF	About 0 V

HINT:

If the circuit is not as specified value, check and repair or replace the trouble part shown in the table above.

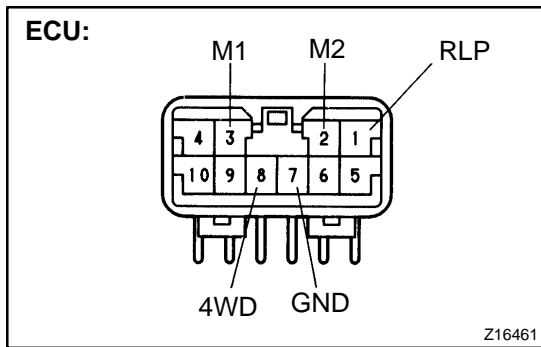

- (c) Inspect the system circuit with the connector connected.
- (1) Turn the ignition switch to the ON position.
 - (2) Shift the transfer shift lever to L position.
 - (3) Using a voltmeter, measure the voltage when the differential lock control switch is in the position, as shown in the table.

Tester Connection ⊕ - ⊖	Switch position	Specified value
4WD - GND	-	10 - 14 V
RLP - GND	RR*	0.5 V or less
M1 - M2	OFF → RR	0.5 V or less → 10 - 14 V (Approx. 1 sec.) → 0.5 V or less
M2 - M1	RR → OFF	

*: The rear differential should be locked mechanically.
 If the circuit is not as specified value, replace the ECU.

- (4) Install the ECU in place.

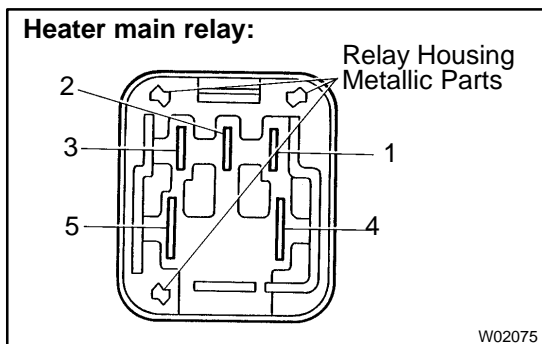

3. INSPECT DIFF. LOCK COMPONENTS

(a) Inspect the relay operation.

- (1) Jack up the vehicle.
- (2) Use a heater main relay and connect it, as shown below.

NOTICE:

Connect the terminals being careful not to touch the neighboring terminals or metallic parts of the relay housing.

- (3) Rotate the tire and check that differential lock has occurred.

If operation is not as specified, replace the actuator.

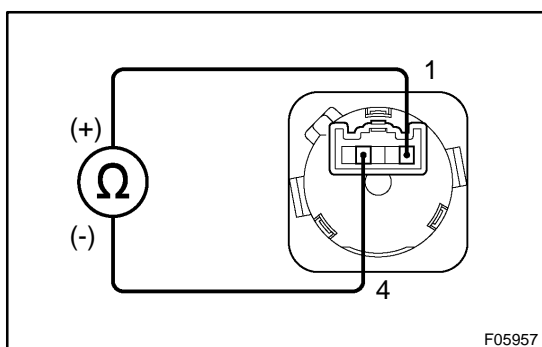
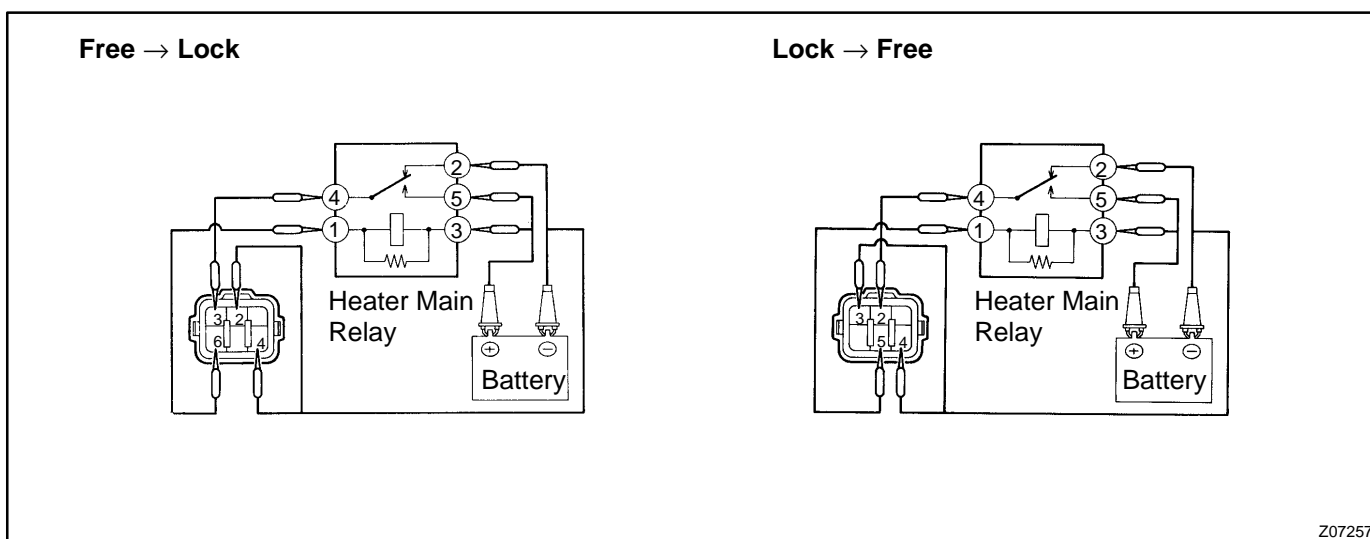

(b) Inspect the diff. lock control switch continuity.

Inspect the switch continuity between terminal 1 to terminal 4.

HINT:

If continuity does not exist, replace the switch.

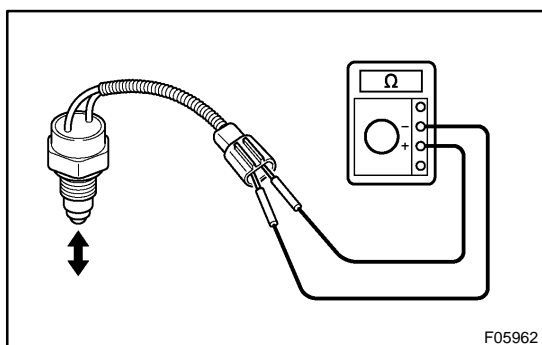

(c) Inspect the diff. lock indicator switch.

- (1) Check that continuity exists between terminals 1 and 2 when the switch is pushed (differential connected position).
- (2) Check that no continuity exists when the switch is free (differential disconnected position).

HINT:

If operation is not as specified, replace the switch.

- (d) Inspect the L position switch (See page [TR-49](#)).
- (e) Inspect the vehicle speed sensor (See page [BE-63](#)).

REMOVAL

1. SHIFTING REAR DIFF. LOCK POSITION

- (a) Turn the ignition switch to the ON position.
- (b) Shift the transfer shift lever to L position.

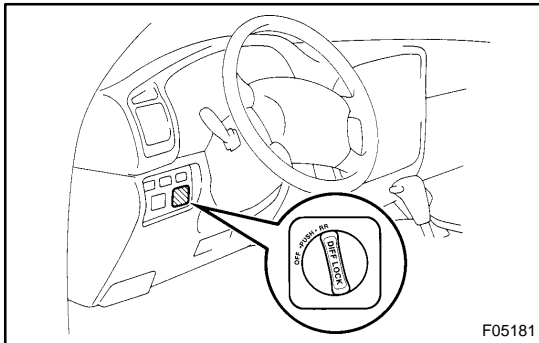

- (c) Turn the differential lock control switch to the RR position and lock the rear differential.

HINT:

While rotating the rear wheels, check they are in the differential lock condition.

- (d) Disconnect the cable from the negative terminal of the battery.

2. REMOVE NO. 1 ACTUATOR PROTECTOR

Remove the nut, bolt and No. 1 actuator protector.

3. REMOVE NO. 2 ACTUATOR PROTECTOR

Remove the 2 nuts and No. 2 actuator protector.

4. DISCONNECT CONNECTORS AND TUBE

5. REMOVE REAR DIFF. LOCK POSITION SWITCH

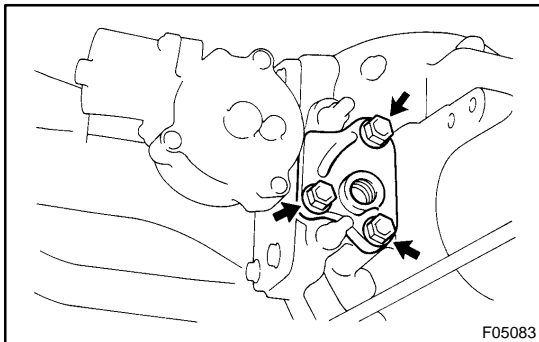

6. REMOVE COVER

- (a) Remove the 3 bolts.
- (b) Using a brass bar and hammer, remove the cover.

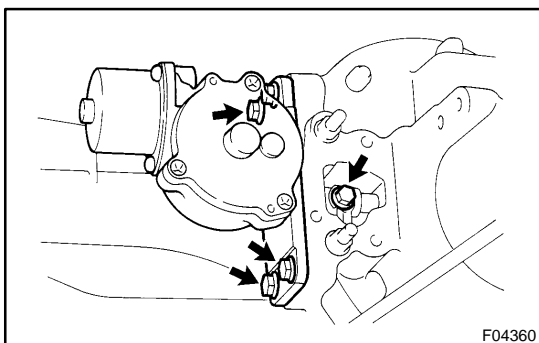

7. REMOVE ACTUATOR

- (a) Remove the shift fork set bolt.
- (b) Remove the 4 bolts.
- (c) Using a screwdriver, pry out the actuator.

FRONT AXLE HUB COMPONENTS

SA143-04

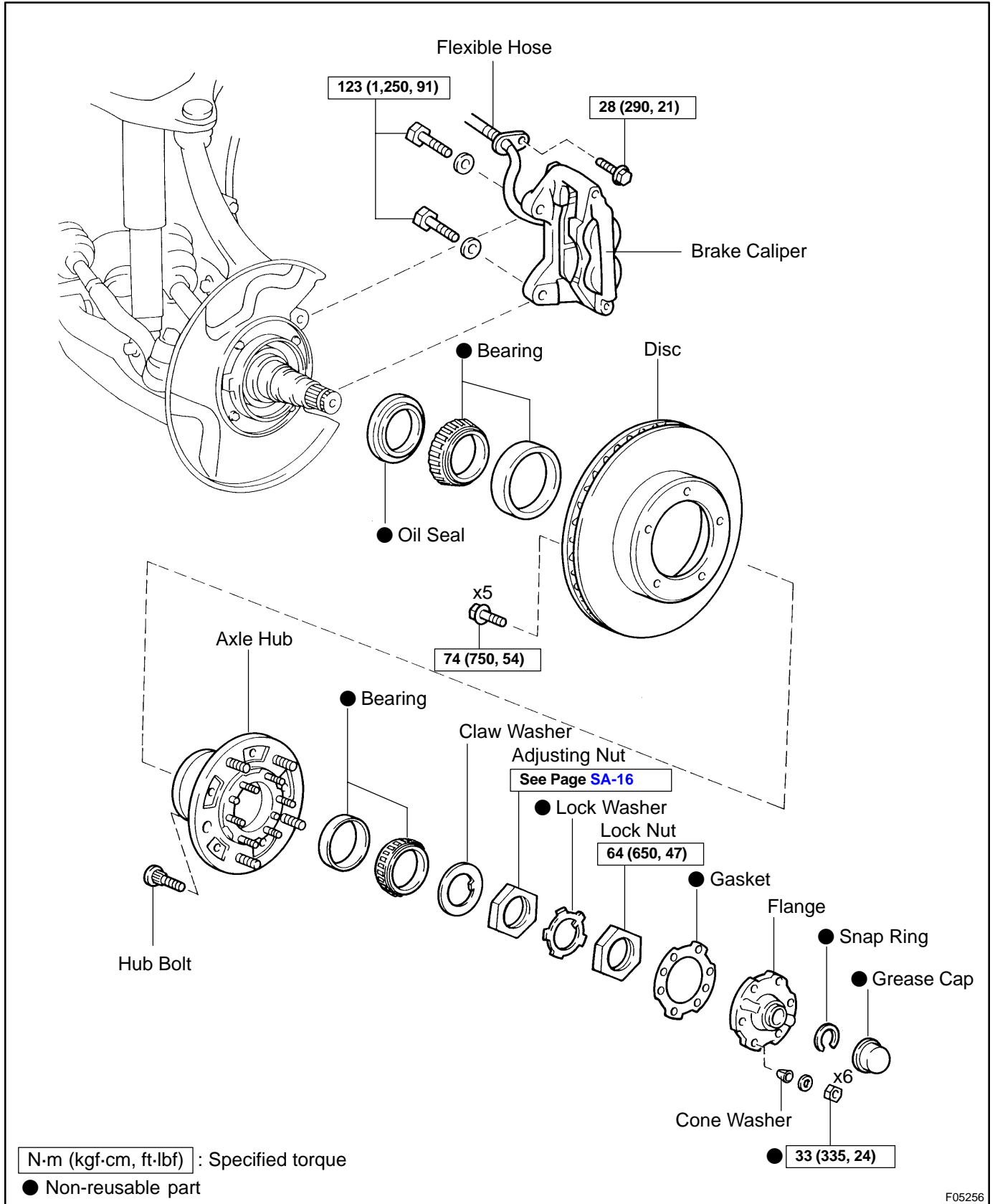

F05256

DISASSEMBLY

1. REMOVE OIL SEAL AND BEARING

- (a) Using a screwdriver, pry out the oil seal.
- (b) Remove the bearing from the axle hub.

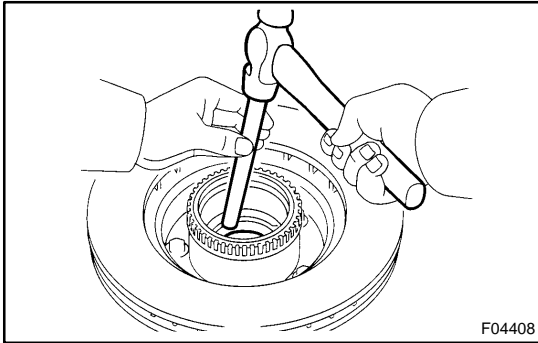

2. REMOVE BEARING OUTER RACES

- (a) Using a brass bar and hammer, remove the outside bearing outer race.

NOTICE:

Be careful not to damage the ABS speed sensor rotor.

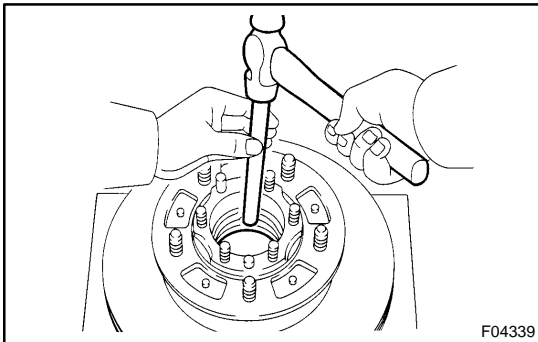

- (b) Using a brass bar and hammer, remove the inside bearing outer race.

3. INSPECT BEARINGS

Clean the bearings and outer races and inspect them for wear or damage.

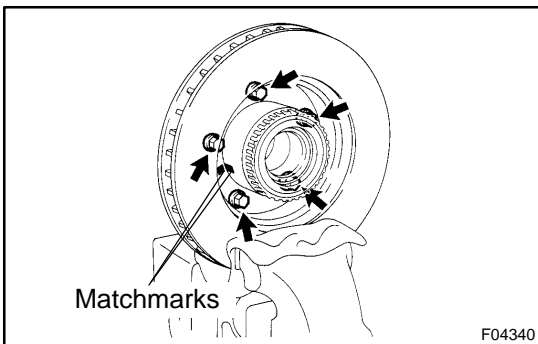

4. REMOVE DISC

- (a) Mount the axle hub with the disc in a soft jaw vice.

NOTICE:

Close vice until it holds disc, do not tighten further.

- (b) Place matchmarks on the axle hub and disc.
- (c) Remove the 5 bolts and separate the axle hub and disc.

INSTALLATION

1. INSTALL AXLE HUB TO STEERING KNUCKLE

- (a) Place the axle hub with disc to the steering knuckle.

NOTICE:

Be careful not to damage the ABS speed sensor rotor and oil seal.

- (b) Install the outer bearing.
(c) Install the claw washer.

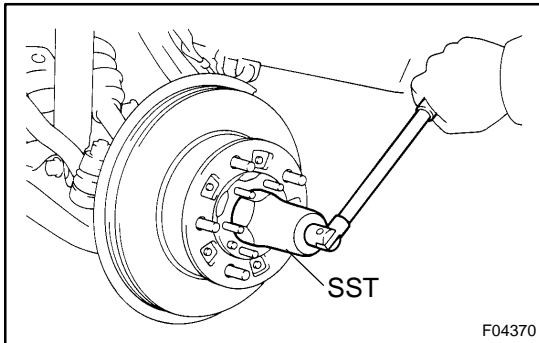

2. ADJUST PRELOAD

- (a) Install the adjusting nut and using SST, tighten it.

SST 09607-60020

Torque: 59 N·m (600 kgf·cm, 43 ft·lbf)

- (b) Turn the axle hub several times to settle down the bearing.

- (c) Using SST, loosen the adjusting nut until it can rotate by hand.

SST 09607-60020

- (d) Using SST, retighten the adjusting nut.

SST 09607-60020

Torque: 4.3 - 6.5 N·m (44 - 66 kgf·cm, 38 - 57 in.-lbf)

HINT:

Check that there is no looseness on the bearing.

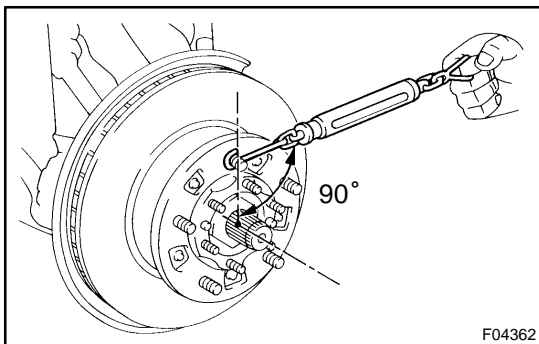

- (e) Using a spring tension gauge, measure the preload.

Preload (at starting):

42 - 67 N (4.3 - 6.8 kgf, 9.5 - 15.0 lbf)

3. INSTALL LOCK WASHER AND LOCK NUT

- (a) Install a new lock washer and the lock nut.

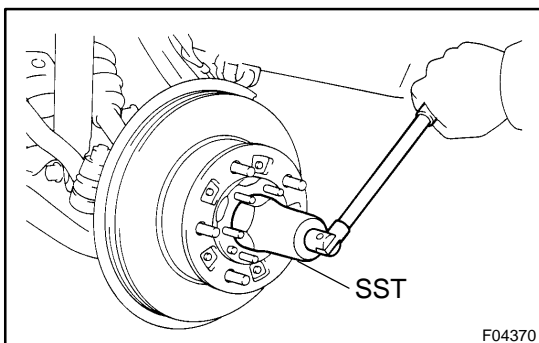

- (b) Using SST, torque the lock nut.

SST 09607-60020

Torque: 64 N·m (650 kgf·cm, 47 ft·lbf)

- (c) Check that the axle hub rotates smoothly and there is no looseness on the bearing.

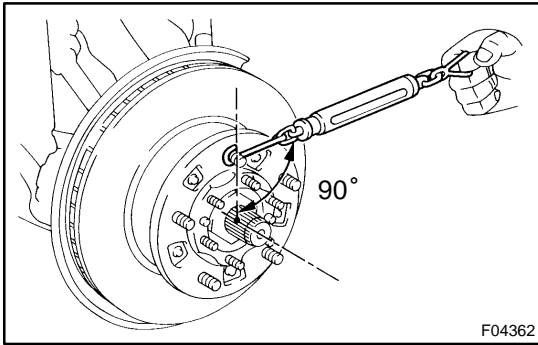

- (d) Using a spring tension gauge, check the preload.

Preload (at starting):

42 - 67 N (4.3 - 6.8 kgf, 9.5 - 15.0 lbf)

HINT:

Make sure to check preload in the direction of rotation.

If the preload is not within the specified value, adjust it again with the adjusting nut.

- (e) Secure the lock nut by bending one of the lock washer teeth inward and the other lock washer teeth outward.

4. INSTALL FLANGE

- (a) Place a new gasket in position on the axle hub.
 (b) Install the flange to the axle hub.
 (c) Install the 6 cone washers, washers and new nuts.

Torque: 33 N·m (335 kgf·cm, 24 ft·lbf)

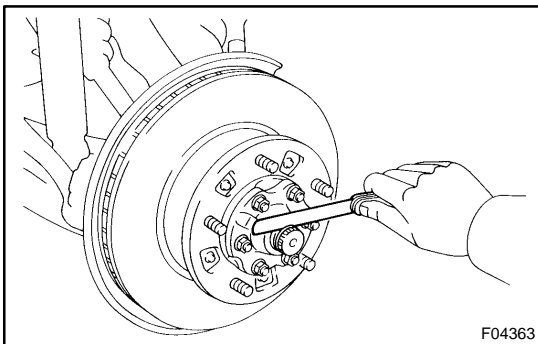

- (d) Pull out the drive shaft to the outside of the vehicle and select the snap ring which ensures the clearance between the tip of the flange and the snap ring is less than 0.2 mm (0.008 in.).

Snap ring thickness:

1.8 mm (0.0709 in.)	2.4 mm (0.0945 in.)
2.0 mm (0.0787 in.)	2.6 mm (0.1024 in.)
2.2 mm (0.0866 in.)	2.8 mm (0.1102 in.)

- (e) Using a snap ring expander, install a new snap ring to the drive shaft.

- (f) Install a new grease cap to the flange.

5. INSTALL BRAKE CALIPER

- (a) Install the brake caliper, washers and 2 bolts.

Torque: 123 N·m (1,250 kgf·cm, 91 ft·lbf)

- (b) Install the flexible hose and bolt to the steering knuckle.

Torque: 28 N·m (290 kgf·cm, 21 ft·lbf)

6. INSTALL FRONT WHEEL

Torque: 131 N·m (1,340 kgf·cm, 97 ft·lbf)

7. CHECK ABS SPEED SENSOR SIGNAL

(See page [DI-505](#))

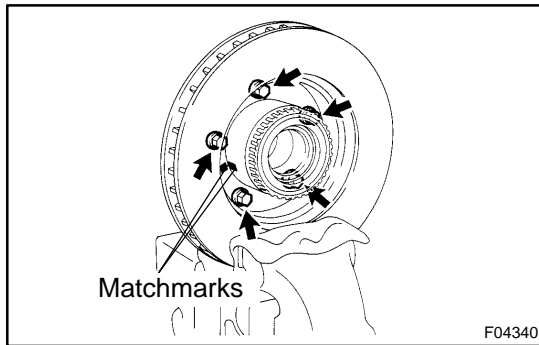

REASSEMBLY

1. INSTALL DISC

- (a) Mount the disc in a soft jaw vice.

NOTICE:

Close vice until it holds disc, do not tighten further.

- (b) Align the matchmarks on the axle hub and disc.
 (c) Install the 5 bolts to the axle hub.

Torque: 74 N·m (750 kgf-cm, 54 ft-lbf)

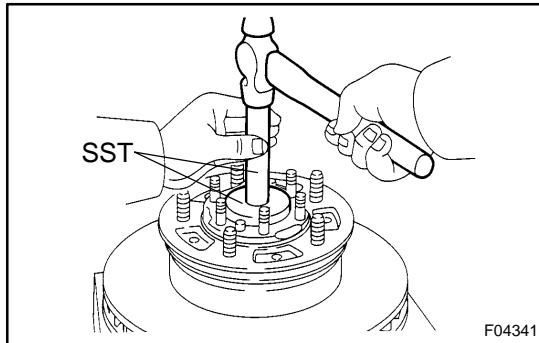

2. INSTALL BEARING OUTER RACES

- (a) Using SST and a hammer, carefully install a new outside bearing outer race.

SST 09950-60020 (09951-00730),
 09950-70010 (09951-07100)

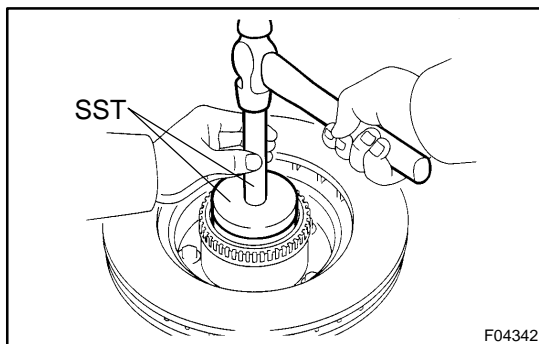

- (b) Using SST and a hammer, carefully install a new inside bearing outer race.

SST 09950-60020 (09951-00890),
 09950-70010 (09951-07100)

NOTICE:

Be careful not to damage the ABS speed sensor rotor.

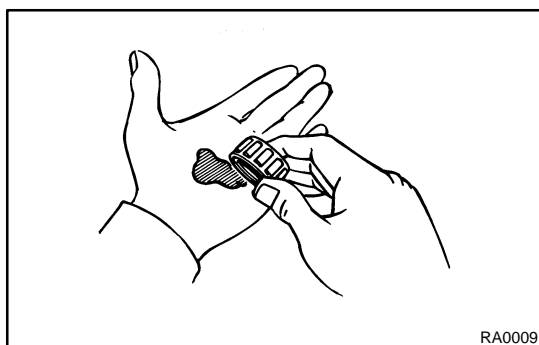

3. PACK BEARING WITH MP GREASE

- (a) Place MP grease in the palm of your hand.
 (b) Pack grease into a new bearing, continuing until the grease oozes out from the other side.
 (c) Employ the same manner around the bearing circumference.

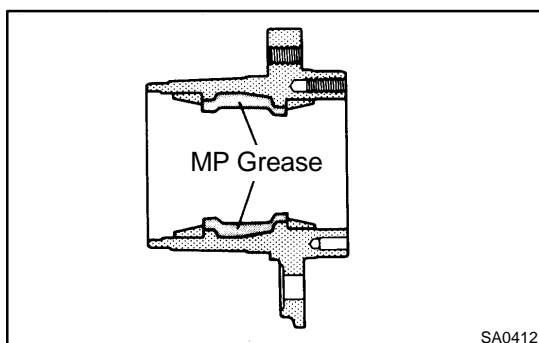

4. COAT INSIDE OF AXLE HUB WITH MP GREASE

5. INSTALL INNER BEARING AND OIL SEAL

- (a) Place the inner bearing into the axle hub.

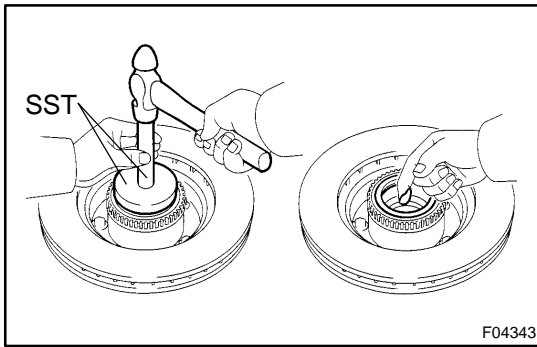

- (b) Using SST and a hammer, install a new oil seal into the axle hub.

SST 09950-60020 (09951-01030),
09950-70010 (09951-07100)

NOTICE:

Be careful not to damage the ABS speed sensor rotor.

- (c) Coat the lip of the oil seal with MP grease.

REMOVAL

1. REMOVE FRONT WHEEL

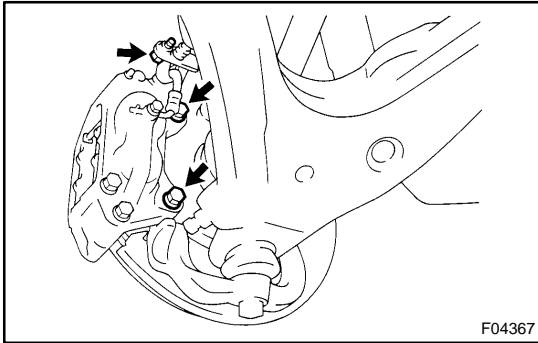

2. REMOVE BRAKE CALIPER

- (a) Remove the bolt and disconnect the flexible hose from the steering knuckle.
- (b) Remove the 2 bolts, washers and brake caliper.
- (c) Support the brake caliper securely.

3. REMOVE FLANGE

- (a) Using a screwdriver and hammer, remove the grease cap from the flange.
- (b) Using a snap ring expander, remove the snap ring.
- (c) Remove the 6 nuts and washers.
- (d) Install the 6 nuts temporarily to protect the threads of the stud bolts.

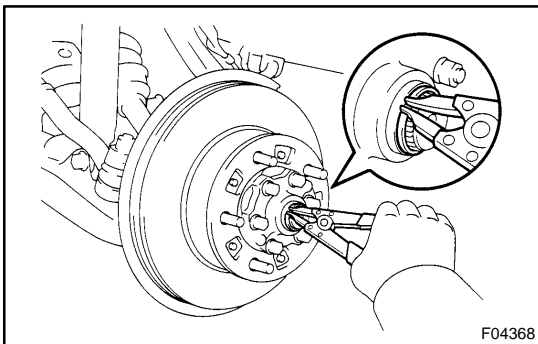

- (e) Using a brass bar and hammer, tap on the bolt heads and remove the 6 nuts and cone washers.
- (f) Remove the flange and gasket.

4. REMOVE AXLE HUB WITH DISC

- (a) Using a screwdriver, release the lock washer.

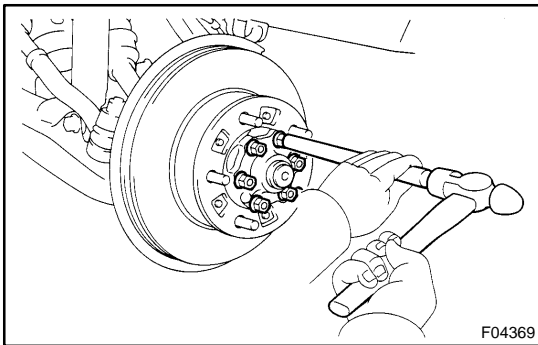

- (b) Using SST, remove the lock nut.
SST 09607-60020
- (c) Remove the lock washer.
- (d) Using SST, remove the adjusting nut.
SST 09607-60020
- (e) Remove the axle hub with disc.

NOTICE:

Be careful not to damage the ABS speed sensor rotor and oil seal.

- (f) Remove the claw washer and bearing from the axle hub.

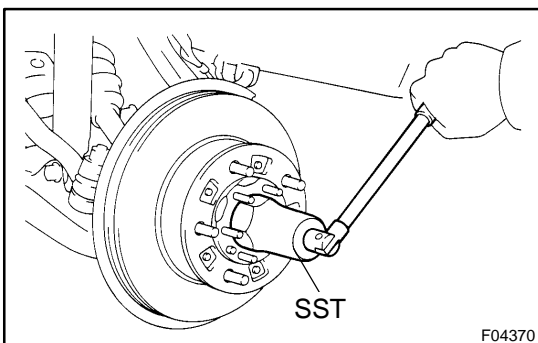

FRONT DIFFERENTIAL CARRIER COMPONENTS

SA1SE-01

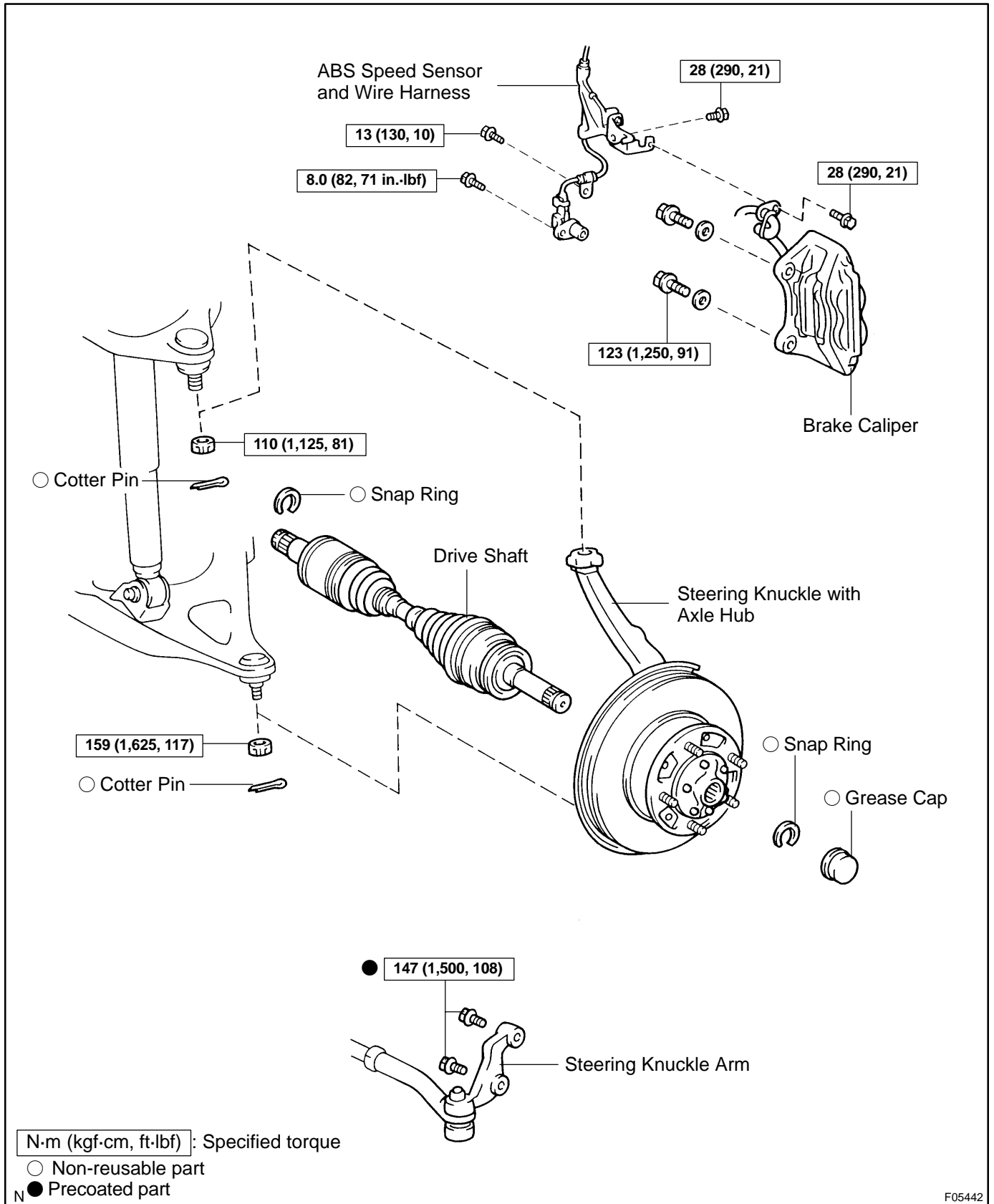

F05442

SUSPENSION AND AXLE - FRONT DIFFERENTIAL CARRIER

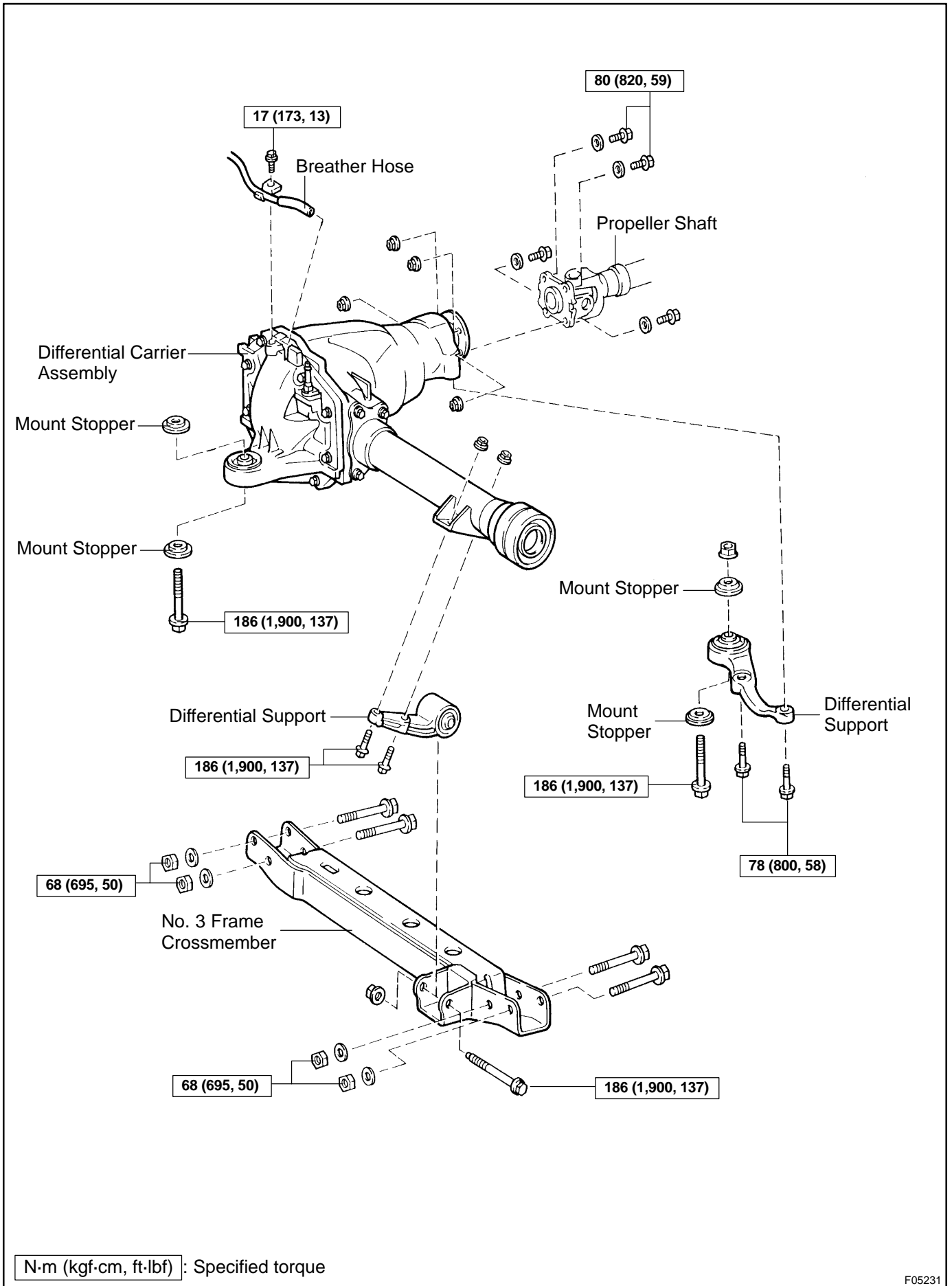

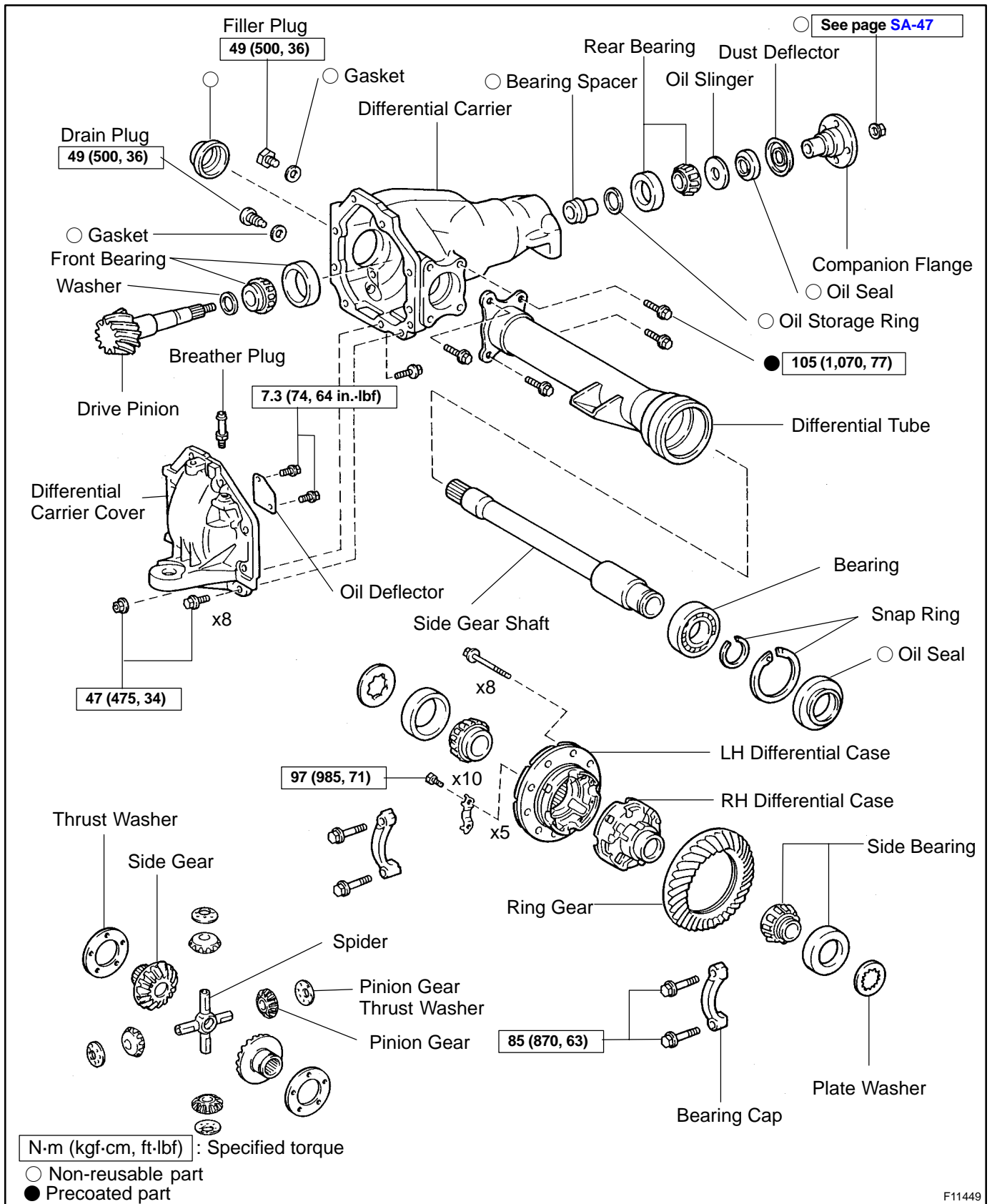

F11449

DISASSEMBLY

1. REMOVE DIFFERENTIAL CARRIER COVER

- (a) Remove the 9 bolts and nut from the carrier cover.
- (b) Using a brass bar and hammer, separate the cover from carrier.
- (c) Remove the breather plug from the differential carrier cover.
- (d) Remove the 2 bolts and oil deflector from the differential carrier cover.

2. SET DIFFERENTIAL CARRIER TO OVERHAUL STAND, ETC.

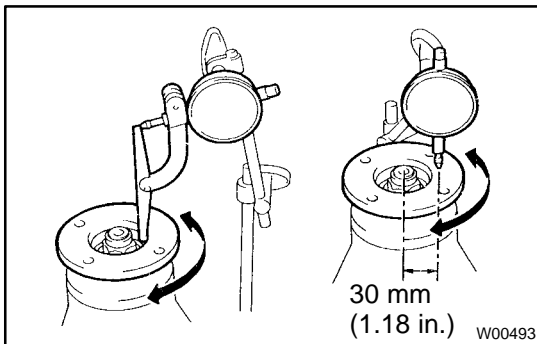

3. CHECK RUNOUT OF COMPANION FLANGE

Using a dial indicator, measure the vertical and lateral runout of the companion flange.

Maximum: 0.09 mm (0.0035 in.)

If the runout is greater than the maximum, replace the companion flange.

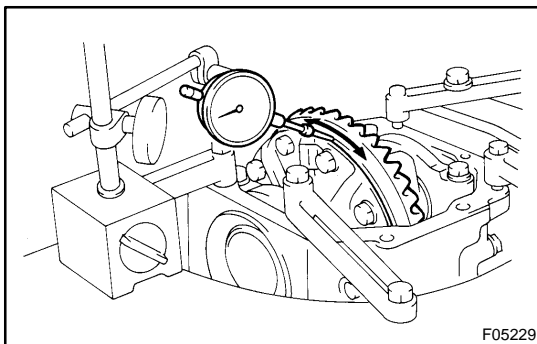

4. CHECK RING GEAR RUNOUT

Using a dial indicator, measure the ring gear runout.

Maximum runout: 0.07 mm (0.0028 in.)

If the runout is greater than the maximum, replace the ring gear and drive pinion as a set.

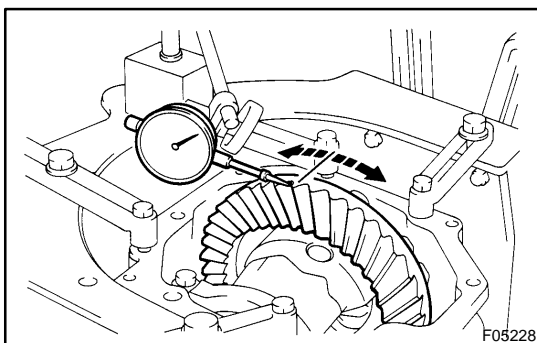

5. CHECK RING GEAR BACKLASH

Using a dial indicator, while holding the drive pinion flange measure the ring gear backlash.

Backlash: 0.13 - 0.18 mm (0.0051 - 0.0071 in.)

HINT:

Measure at 3 or more places on the circumference of the ring gear.

If the backlash is not within the specification, adjust the backlash.

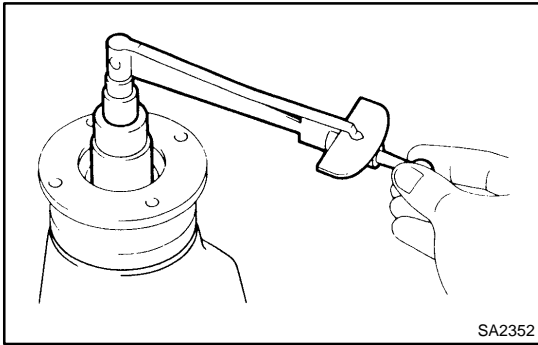
**6. MEASURE DRIVE PINION PRELOAD**

Using a torque wrench, measure the drive pinion preload using the backlash of the drive pinion and ring gear.

Preload (at starting):

0.5 - 0.8 N-m (5 - 8 kgf-cm, 4.3 - 6.9 in.-lbf)

7. CHECK TOTAL PRELOAD

Using a torque wrench, measure the total preload.

Total preload (at starting):

Drive pinion preload plus

0.4 - 0.6 N-m (4 - 6 kgf-cm, 3.5 - 5.2 in.-lbf)

If necessary, disassemble and inspect the differential.

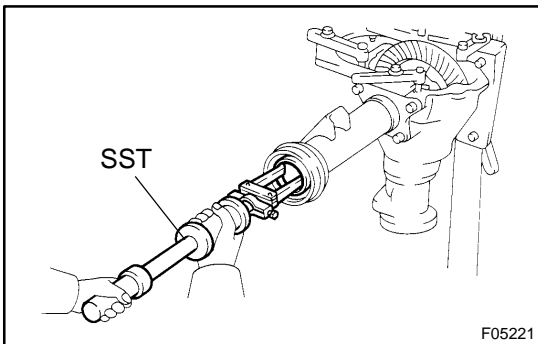
8. INSPECT TOOTH CONTACT BETWEEN RING GEAR AND DRIVE PINION (See page SA-47)**9. REMOVE SIDE GEAR SHAFT OIL SEALS**

Using SST, remove the 2 side gear shaft oil seals.

SST 09308-00010

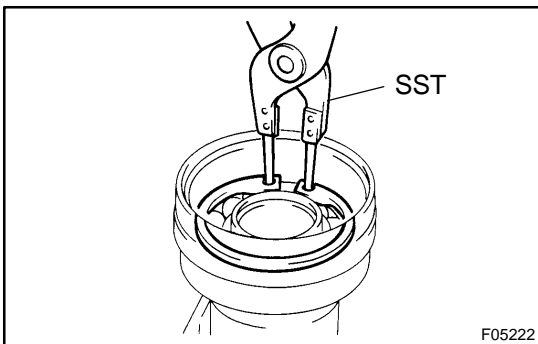
**10. REMOVE DIFFERENTIAL TUBE ASSEMBLY**

(a) Using SST, remove the snap ring.

SST 09350-30020 (09350-07060)

(b) Using a snap ring expander, remove the snap ring.

(c) Remove the 4 bolts and differential tube with side gear shaft from the differential carrier.

(d) Remove the side gear shaft from the differential tube.

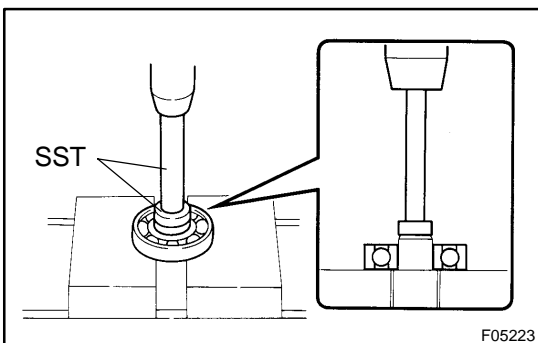
**11. REMOVE SIDE GEAR BEARING**

Using SST and a press, remove the bearing from side gear shaft.

SST 09950-60010 (09951-00410), 09950-70010
(09951-07100)

12. REMOVE COMPANION FLANGE

(a) Using a chisel and hammer, unstake the nut.

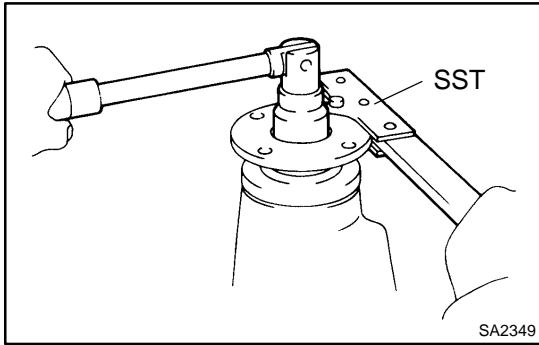

- (b) Using SST to hold the flange, remove the nut.
SST 09330-00021

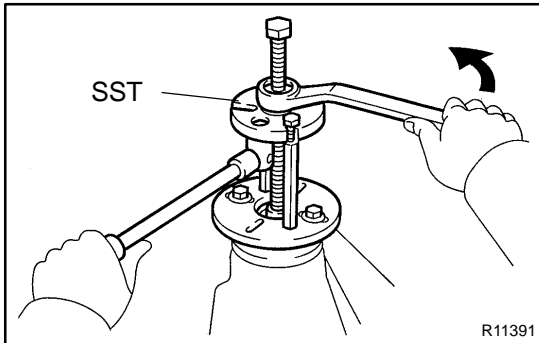

- (c) Using SST, remove the companion flange.
SST 09950-30012 (09951-03010, 09953-03010,
09954-03010, 09955-03030, 09956-03020)

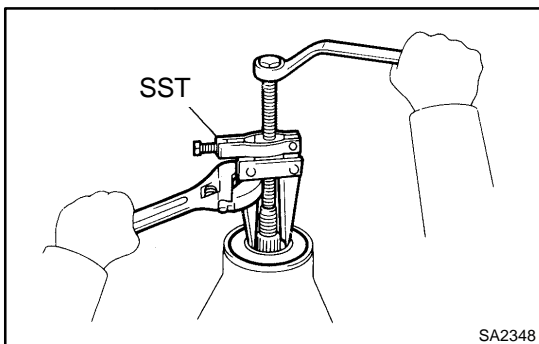

13. REMOVE OIL SEAL AND OIL SLINGER

- (a) Using SST, remove the oil seal from the differential carrier.
SST 09308-10010
(b) Remove the oil slinger.

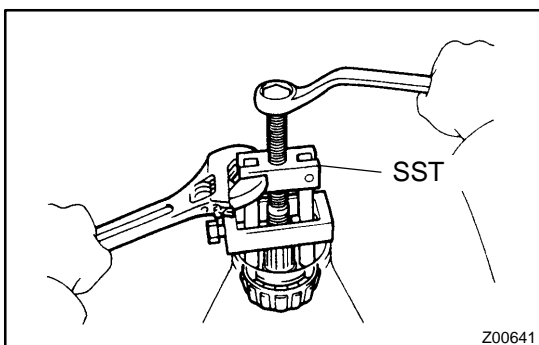

14. REMOVE REAR BEARING

- Using SST, remove the rear bearing from the drive pinion.
SST 09556-22010
If the rear bearing is damaged or worn, replace the rear bearing.

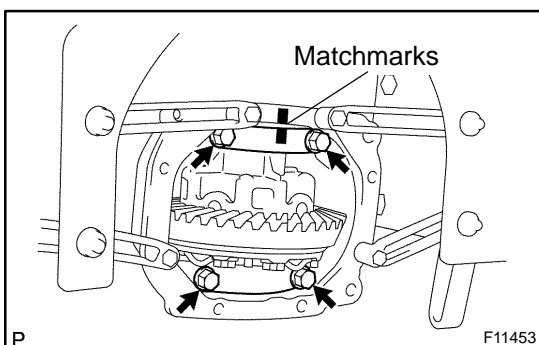

15. REMOVE DIFFERENTIAL CASE ASSEMBLY

- (a) Place matchmarks on the bearing cap and differential carrier.
(b) Remove the 4 bolts and 2 bearing caps.

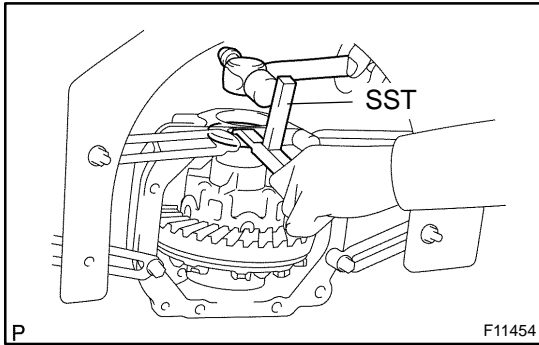

- (c) Using SST and a hammer, remove the 2 side bearing plate washers.

SST 09504-22012

HINT:

Measure the plate washer and note down the thickness.

- (d) Remove the differential case with the bearing outer races from the differential carrier.

HINT:

Tag the bearing outer races to show the location for reassembling.

16. REMOVE DRIVE PINION AND BEARING SPACER FROM DIFFERENTIAL CARRIER

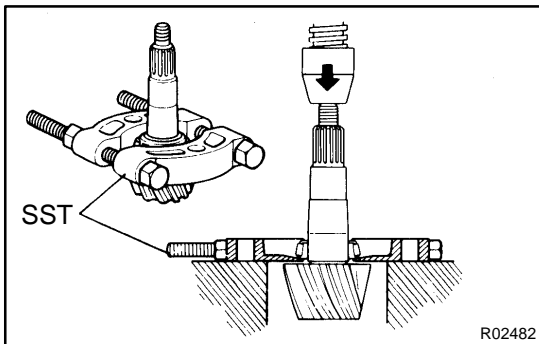

17. REMOVE DRIVE PINION FRONT BEARING

- (a) Using SST and a press, remove the front bearing from the drive pinion.

SST 09950-00020

HINT:

If the drive pinion or ring gear is damaged, replace them as a set.

- (b) Remove the washer.

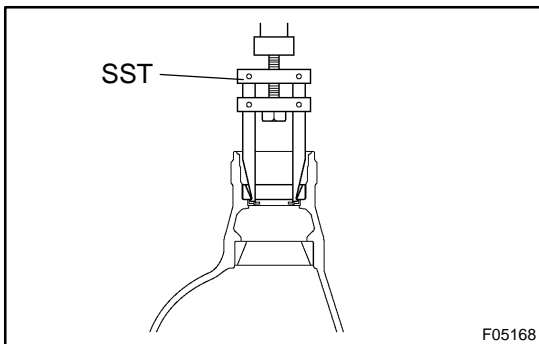

18. REMOVE DRIVE PINION FRONT AND REAR BEARING OUTER RACES AND OIL STORAGE RING

- (a) Using SST, remove the rear bearing outer race.

SST 09308-00010

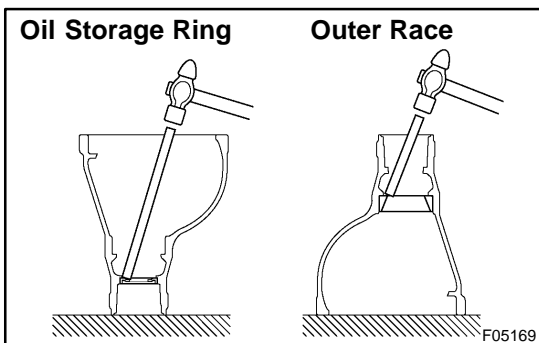

- (b) Using a brass bar and hammer, remove the oil storage ring and front bearing outer race.

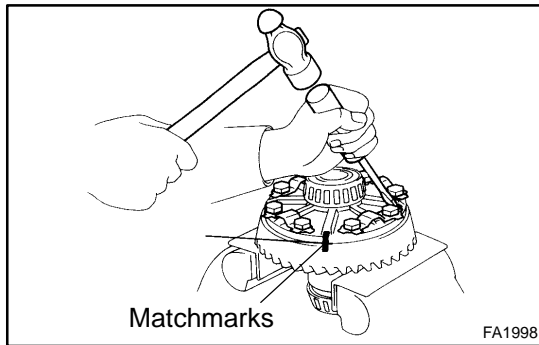
**19. REMOVE RING GEAR**

- Place matchmarks on the ring gear and differential case.
- Using a screwdriver and hammer, unstick the 5 lock plates.
- Remove the 10 bolts and 5 lock plates.
- Using a plastic hammer, tap on the ring gear to separate it from the differential case.

20. CHECK DIFFERENTIAL CASE RUNOUT

- Place the bearing outer races on their respective bearings. Check that the left and right outer races are not interchanged.
- Install the assembled plate washers onto the side bearing.
- Install the differential case in the differential carrier.

HINT:

If it is difficult to install the differential case into the carrier, replace the plate washer with a thinner one.

However, select a plate washer that allows no clearance between it and the carrier.

- Align matchmarks on the bearing cap and differential carrier.
- Install and uniformly tighten the 4 bolts a little at a time.

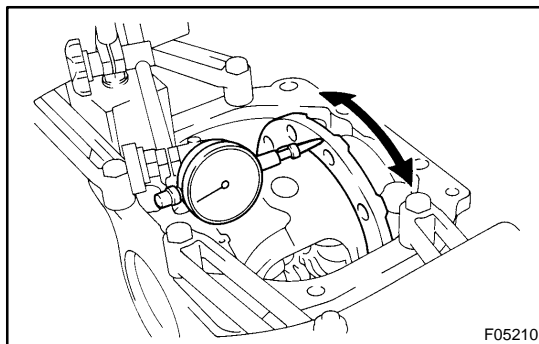

- Using a dial indicator, measure the differential case runout.

Maximum case runout: 0.07 mm (0.0028 in.)

If the runout is greater than the maximum, replace the differential case and side bearings as a set.

- Remove the differential case.

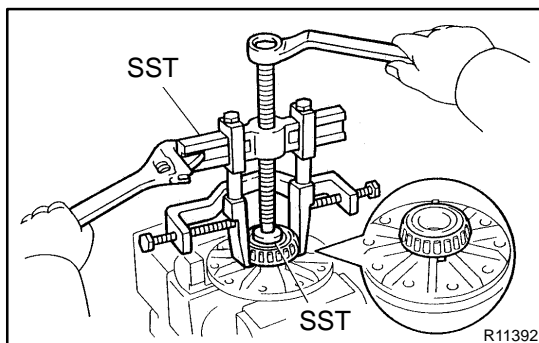
**21. REMOVE SIDE BEARINGS**

Using SST, remove the 2 side bearings from the differential case.

SST 09950-40011 (09951-04020, 09952-04010, 09953-04030, 09954-04010, 09955-04061, 09957-04010, 09958-04011), 09950-60010 (09951-00480)

HINT:

Fix the claws of SST to the notches in the differential case.

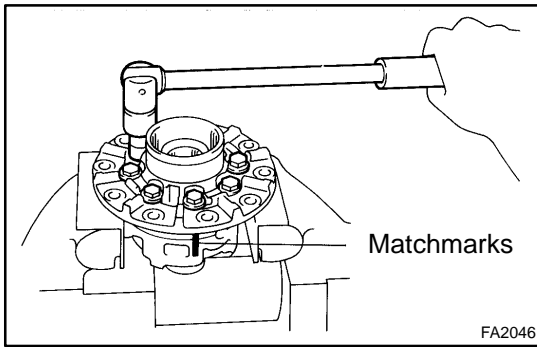
**22. DISASSEMBLE DIFFERENTIAL CASE**

- (a) Place matchmarks on the LH and RH cases.
- (b) Remove the 8 bolts uniformly, a little at a time.
- (c) Using a plastic hammer, separate the LH and RH cases.
- (d) Remove the spider, 2 side gears, side gear thrust washers, 4 pinion gears and pinion gear thrust washers from the RH differential case.

INSTALLATION

Installation is in the reverse order of removal (See page [SA-39](#)).

HINT:

After installation, fill the differential with hypoid gear oil (See page [SA-35](#)).

REASSEMBLY

HINT:

- Using a shop rag, clean off any foreign object from the parts.
- Apply all of the sliding and rotating surfaces with hypoid gear oil.

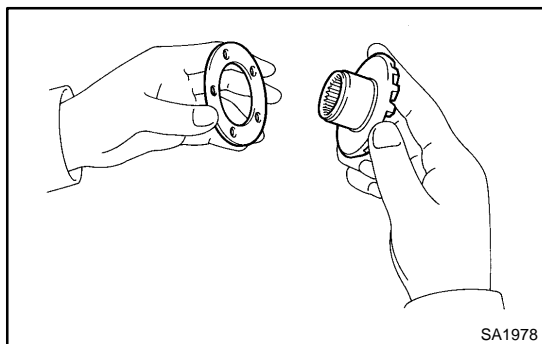

1. MEASURE SIDE GEAR BACKLASH AND ASSEMBLE DIFFERENTIAL CASE

- (a) Install the 2 side gear thrust washers to the side gears.
- (b) Install the 2 side gears to the RH case.
- (c) Install the 4 pinion gears and pinion gear thrust washers to the spider.
- (d) Install the pinion gears with the spider to the RH case.

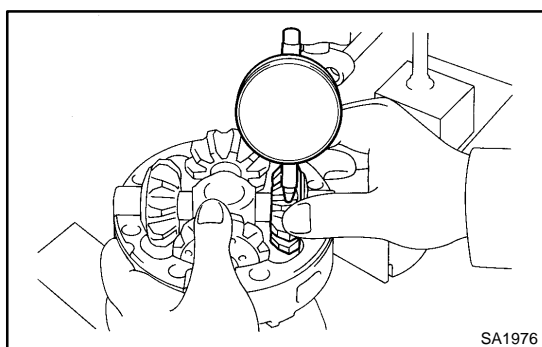

- (e) Using a dial indicator, holding the side gear and spider, measure the side gear backlash,
Backlash: 0.05 - 0.20 mm (0.0020 - 0.0079 in.)

HINT:

- Measure at all 4 locations.
- Measure the backlash at the RH case and at the LH case.

If the backlash is not within the specification, install a thrust washer of a different thickness.

Thrust washer thickness

Thickness mm (in.)	Thickness mm (in.)
0.9 (0.035)	1.2 (0.047)
1.0 (0.039)	1.3 (0.051)
1.1 (0.043)	-

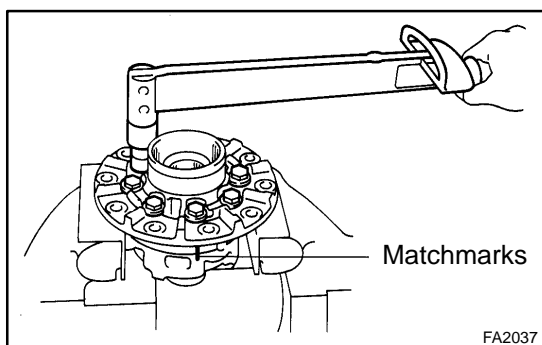

- (f) Align the matchmarks on the LH and RH cases.
- (g) Torque the 8 bolts uniformly a little at a time.
Torque: 47 N·m (480 kgf-cm, 35 ft-lbf)

2. INSTALL RING GEAR ON DIFFERENTIAL CASE

- (a) Clean the contact surfaces of the differential case and ring gear.

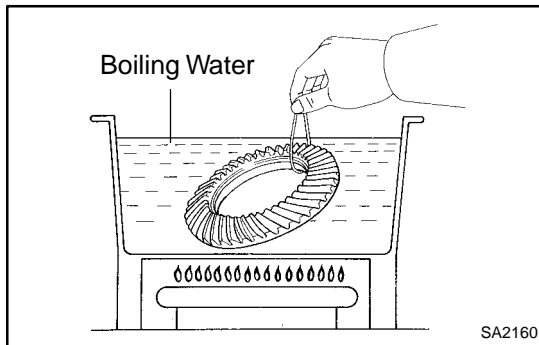

- (b) Heat the ring gear to approx. 100°C (212°F) in boiling water.
 (c) Carefully take the ring gear out of the boiling water.
 (d) After the moisture on the ring gear has completely evaporated, quickly install the ring gear to the differential case.

HINT:

Align the matchmarks on the ring gear and differential case.

- (e) Temporarily install 5 new lock plates and 10 bolts so that the bolt holes in the ring gear and differential case are not misaligned.
 (f) After the ring gear has cooled sufficiently, torque the 10 ring gear set bolts.

Torque: 97 N·m (985 kgf·cm, 71 ft·lbf)

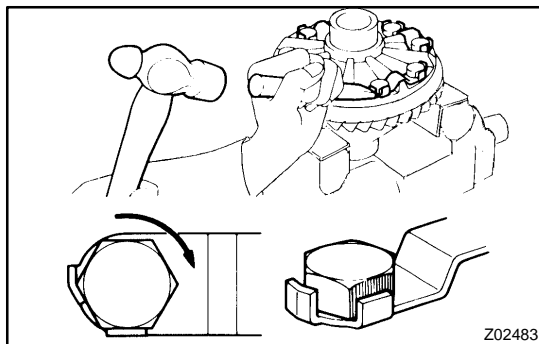

- (g) Using a chisel and hammer, stake the 5 lock plates.

HINT:

Stake the claws of the lock plates to fix the bolts. For the claw contacting the protruding portion of the bolt, stake only the half of it along the tightening direction.

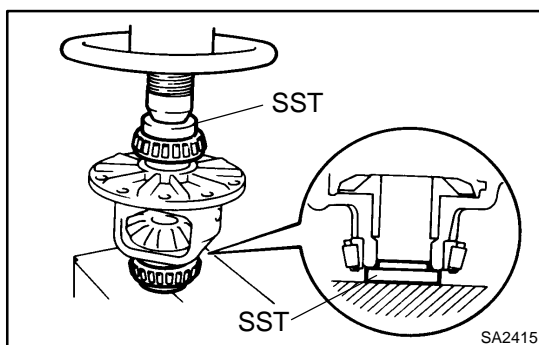
**3. INSTALL SIDE BEARINGS**

Using SST and a press, install the 2 side bearings to the differential case.

SST 09223-15020, 09950-60010 (09951-00480)

4. CHECK RING GEAR RUNOUT

- (a) Place the bearing outer races on their respective bearings. Check that the left and right outer races are not interchanged.
- (b) Install the assembled plate washers onto the side bearing.
- (c) Install the differential case in the differential carrier.

HINT:

If it is difficult to install the differential case into the carrier, replace the plate washer with a thinner one.

However, select a plate washer that allows no clearance between it and the carrier.

- (d) Align matchmarks on the bearing cap and differential carrier.
- (e) Install and uniformly tighten the 4 bolts a little at a time.

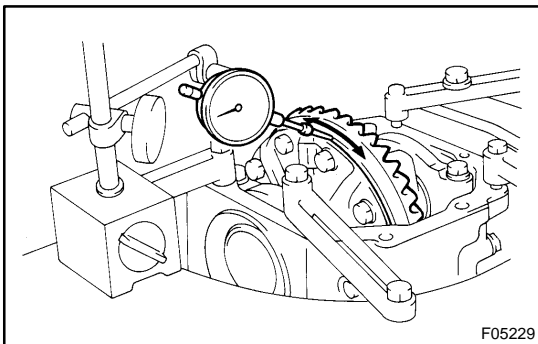

- (f) Using a dial indicator, measure the ring gear runout.
Maximum runout: 0.07 mm (0.0028 in.)
- (g) Remove the differential carrier.

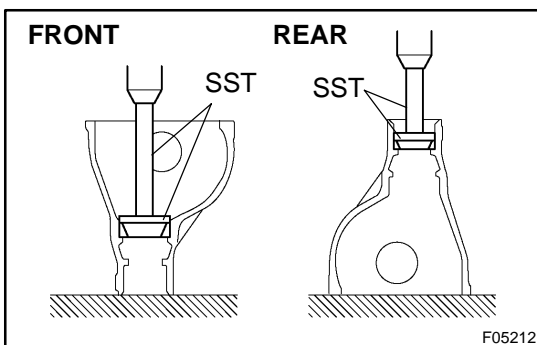
**5. INSTALL DRIVE PINION FRONT AND REAR BEARING OUTER RACES**

- (a) Using SST and a press, install the front bearing outer race.
SST 09950-60020 (09951-00780), 09950-70010 (09951-07150)
- (b) Using SST and a press, install the rear bearing outer race.
SST 09950-60020 (09951-00710), 09950-70010 (09951-07150)

6. INSTALL DRIVE PINION FRONT BEARING

- (a) Install the washer on the drive pinion.

HINT:

First fit a washer with the same thickness as the washer which was removed, then after checking the tooth contact pattern, replace the washer with one of a different thickness if necessary.

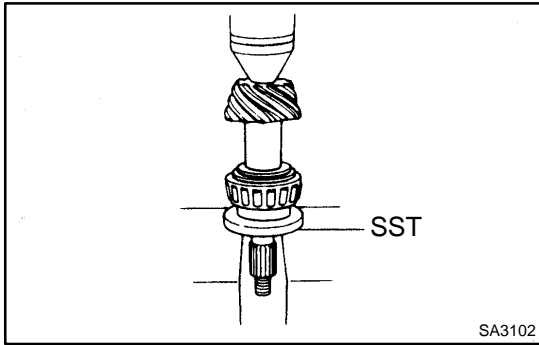

- (b) Using SST and a press, install the front bearing onto the drive pinion.

SST 09506-30012

7. TEMPORARILY ADJUST DRIVE PINION PRELOAD

- (a) Install the drive pinion and rear bearing.

HINT:

Assemble the spacer and oil seal after adjusting the gear contact pattern.

- (b) Install the oil slinger.

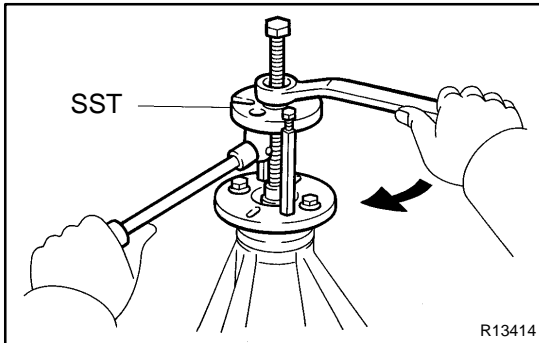

- (c) Using SST, install the companion flange.

SST 09950-30012, (09951-03010, 09953-03010, 09954-03010, 09955-03030, 09956-03020)

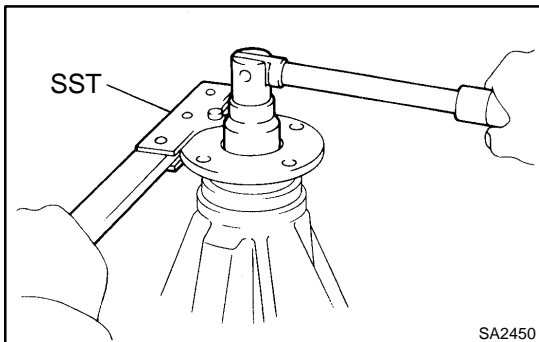

- (d) Using SST to hold the flange and adjust the drive pinion preload by tightening the nut.

NOTICE:

- Coat the nut and threads of the drive pinion with gear oil.
- As there is no spacer, tighten the nut a little at a time, being careful not to overtighten.

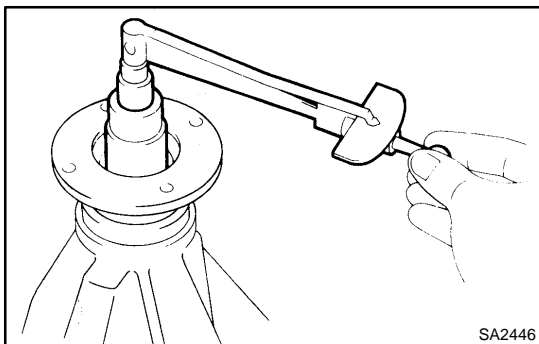

- (e) Using a torque wrench, measure the preload.

Preload (at starting):

New bearing

1.0 - 1.6 N·m (10 - 16 kgf·cm, 8.7 - 13.9 in.-lbf)

Reused bearing

0.5 - 0.8 N·m (5 - 8 kgf·cm, 4.3 - 6.9 in.-lbf)

HINT:

Measure the total preload after turning the bearing clockwise and counterclockwise several times to make the bearing smooth.

8. INSTALL DIFFERENTIAL CASE IN DIFFERENTIAL CARRIER

- (a) Place the bearing outer races on their respective bearings. Check that the left and right outer races are not interchanged.

- (b) Install the differential case in the differential carrier.

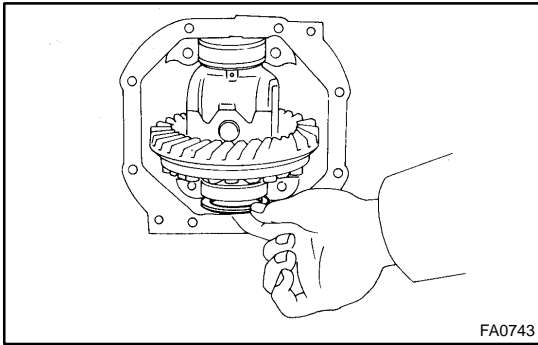

9. ADJUST RING GEAR BACKLASH

(a) Install the plate washer on the ring gear back side.

HINT:

Make sure that the ring gear has backlash.

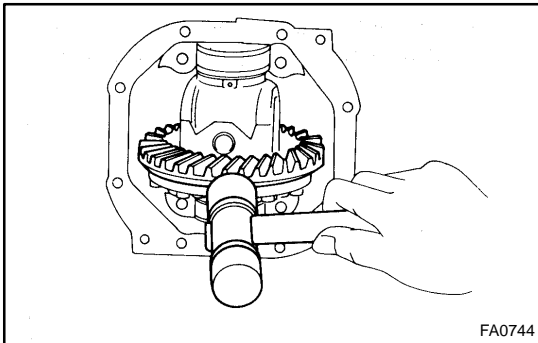

(b) Tap on the ring gear with a plastic hammer so that the washer fits to the bearing.

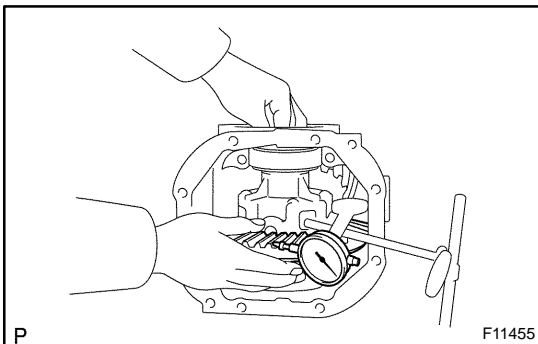

(c) Using a dial indicator, measure the side gear backlash while holding one pinion gear toward the differential case.

Backlash (Reference): 0.13 mm (0.0051 in.)

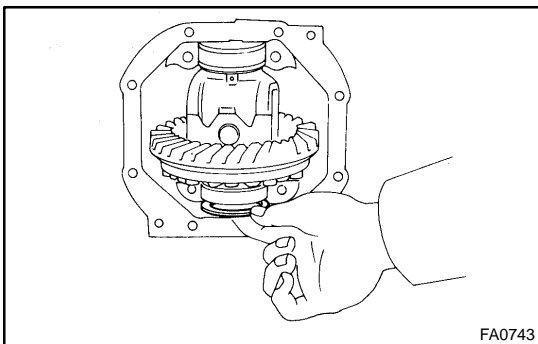

(d) Select a plate washer for back side ring gear, using the backlash as reference.

Side plate washer thickness

Thickness mm (in.)	Thickness mm (in.)
2.58 (0.1016)	3.04 (0.1197)
2.60 (0.1024)	3.06 (0.1205)
2.62 (0.1031)	3.08 (0.1213)
2.64 (0.1039)	3.10 (0.1220)
2.66 (0.1047)	3.12 (0.1228)
2.68 (0.1055)	3.14 (0.1236)
2.70 (0.1063)	3.16 (0.1244)
2.72 (0.1071)	3.18 (0.1252)
2.74 (0.1079)	3.20 (0.1260)
2.76 (0.1087)	3.22 (0.1268)
2.78 (0.1094)	3.24 (0.1276)
2.80 (0.1102)	3.26 (0.1283)
2.82 (0.1110)	3.28 (0.1291)
2.84 (0.1118)	3.30 (0.1299)
2.86 (0.1126)	3.32 (0.1307)
2.88 (0.1134)	3.34 (0.1315)
2.90 (0.1142)	3.36 (0.1323)
2.92 (0.1150)	3.38 (0.1331)
2.94 (0.1157)	3.40 (0.1339)
2.96 (0.1165)	3.42 (0.1346)
2.98 (0.1173)	3.44 (0.1354)
3.00 (0.1181)	3.46 (0.1362)
3.02 (0.1189)	3.48 (0.1370)

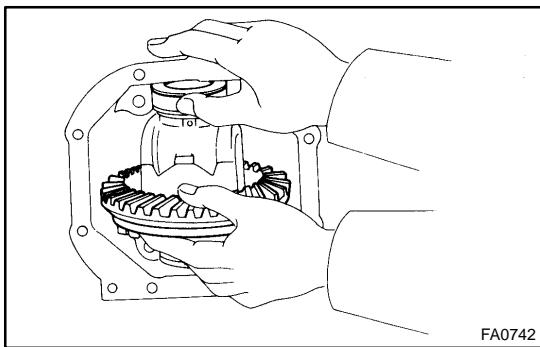

- (e) Select a ring gear teeth side plate washer so that is no clearance between the outer race and case.

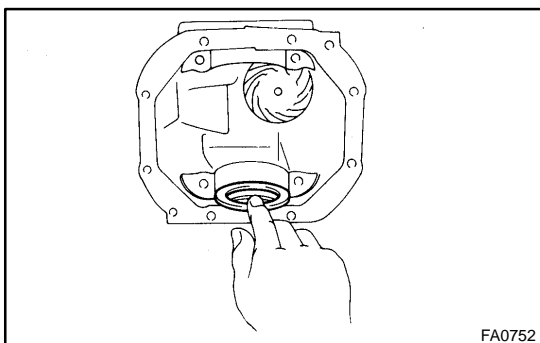

- (f) Remove the plate washers and differential case.
 (g) Install the plate washer into the ring gear back side of the carrier.

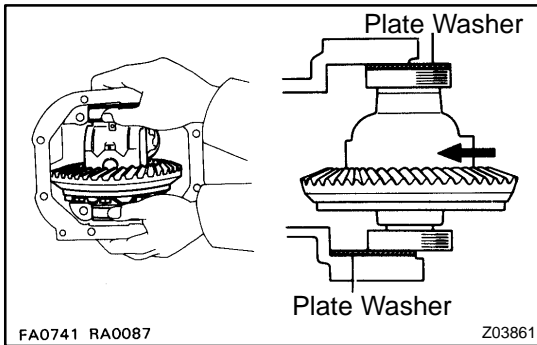

- (h) Place the other plate washer onto the differential case together with the outer race, and install the differential case with the outer race into the carrier.
- (i) Tap on the ring gear with a plastic hammer so that the washers fit to the bearing.

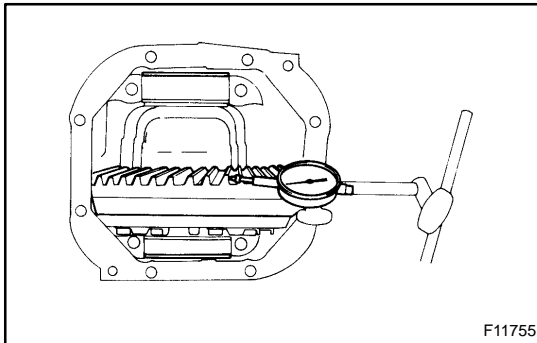

- (j) Using a dial indicator, measure the ring gear backlash.
Backlash: 0.13 - 0.18 mm (0.0051 - 0.0070 in.)
 If the backlash is not within the specification, adjust by either increasing or decreasing the thickness of washers on both sides by an equal amount.

HINT:

There should be no clearance between the plate washer and case.

Make sure that there is ring gear backlash.

10. ADJUST SIDE BEARING PRELOAD

- (a) Remove the ring gear teeth side plate washer and measure the thickness.

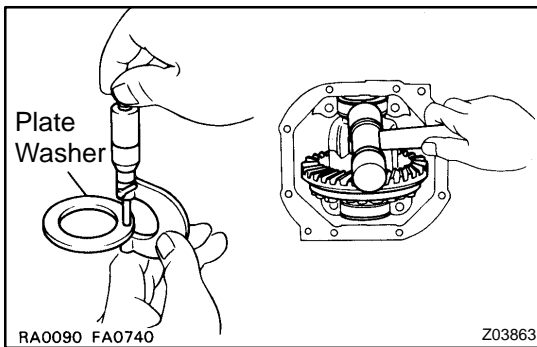

- (b) Using the backlash as a reference, install a new washer of 0.06 - 0.09 mm (0.0024 - 0.0035 in.) thicker than the washer removed.

HINT:

Select a washer which can be pressed in 2/3 of the way with your finger.

- (c) Using a plastic hammer, install the plate washer.
- (d) Align matchmarks on the bearing cap and differential carrier.
- (e) Tighten the 4 bolts.

Torque: 85 N·m (870 kgf·cm, 63 ft·lbf)

HINT:

Turn the ring gear several times to make the side bearings smooth.

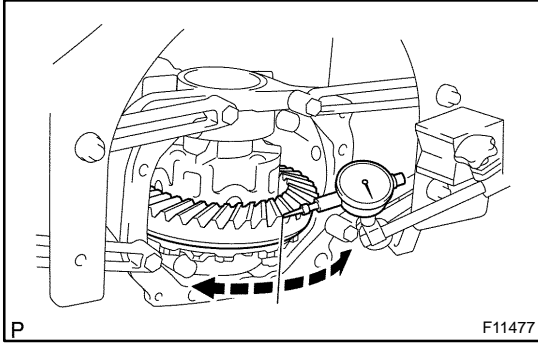

- (f) Using a dial indicator, adjust the ring gear backlash until it is within the specification.

Backlash: 0.13 - 0.18 mm (0.0051 - 0.0070 in.)

If the backlash is not within the specification, adjust by either increasing or decreasing the thickness of washers on both sides by an equal amount.

HINT:

The backlash will change by about 0.02 mm (0.0008 in.) corresponding to 0.03 mm (0.0012 in.) change in the plate washer.

11. MEASURE TOTAL PRELOAD

Using a torque wrench, measure the total preload.

Total preload (at starting):

Drive pinion preload plus

0.4 - 0.6 N·m (4 - 6 kgf·cm, 3.5 - 5.2 in.-lbf)

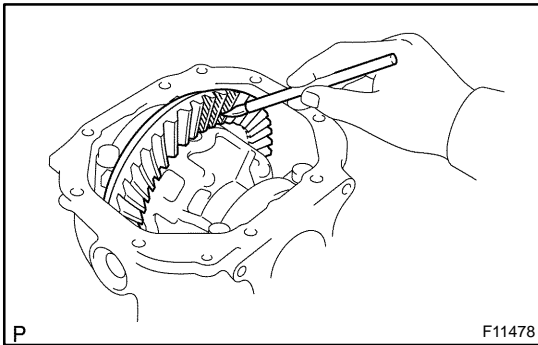

12. INSPECT TOOTH CONTACT BETWEEN RING GEAR AND DRIVE PINION

- Coat 3 or 4 teeth at 3 different positions on the ring gear with red lead primer.
- Hold the companion flange firmly and rotate the ring gear in both directions.
- Inspect the tooth contact pattern.

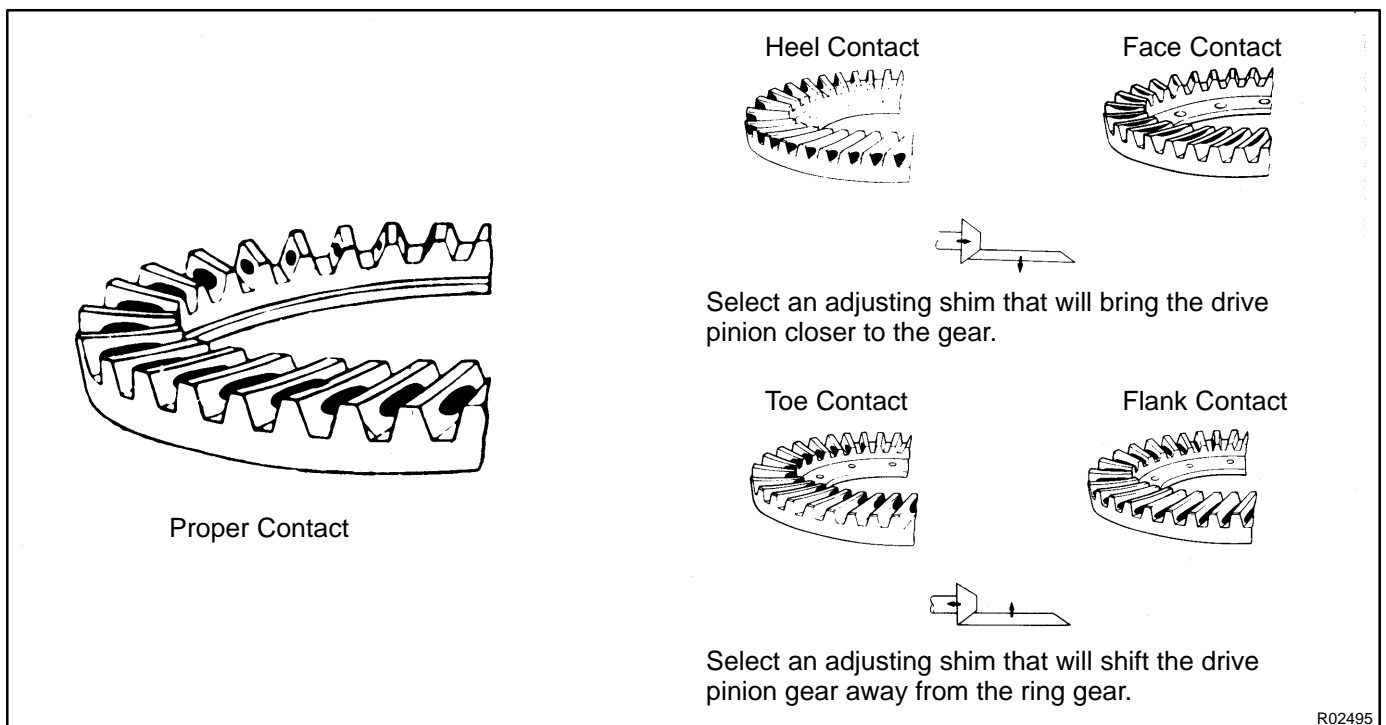

R02495

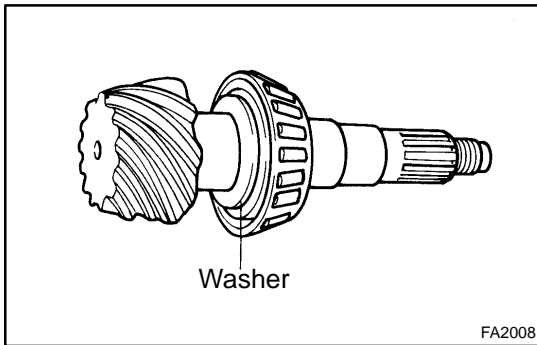

If the teeth are not contacting properly, use the following table to select a proper washer for correction.

Washer thickness

Thickness mm (in.)	Thickness mm (in.)
1.70 (0.0669)	2.03 (0.0799)
1.73 (0.0681)	2.06 (0.0811)
1.76 (0.0693)	2.09 (0.0822)
1.79 (0.0704)	2.12 (0.0835)
1.82 (0.0717)	2.15 (0.0847)
1.85 (0.0729)	2.18 (0.0858)
1.88 (0.0740)	2.21 (0.0870)
1.91 (0.0752)	2.24 (0.0882)
1.94 (0.0764)	2.27 (0.0894)
1.97 (0.0776)	2.30 (0.0906)
2.00 (0.0787)	2.33 (0.0918)

13. REMOVE COMPANION FLANGE (See page SA-40)
14. REMOVE OIL SLINGER
15. REMOVE REAR BEARING (See page SA-40)
16. REMOVE REAR BEARING OUTER RACE
(See page SA-40)

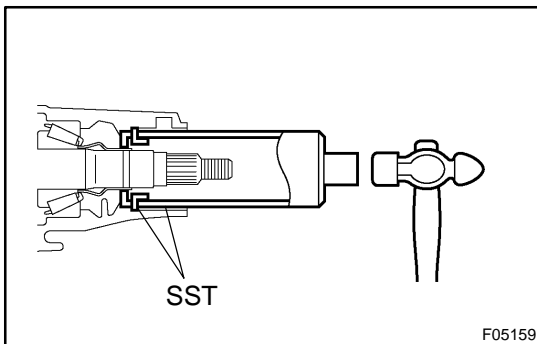

17. INSTALL BEARING SPACER AND OIL STORAGE RING

- (a) Install a new bearing spacer.
- (b) Using SST and a hammer, install a new oil storage ring.
SST 09316-6001 1 (09316-00011), 09506-35010

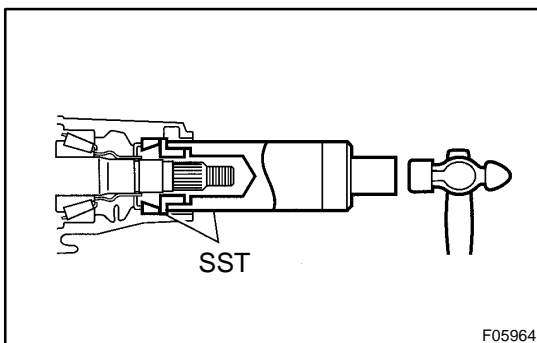

18. INSTALL REAR BEARING OUTER RACE

Using SST and a hammer, install the bearing outer race.
SST 09316-6001 1 (09316-00011), 09506-35010

19. INSTALL REAR BEARING AND OIL SLINGER

20. INSTALL OIL SEAL

- (a) Coat the hypoid gear oil to a new oil seal periphery.

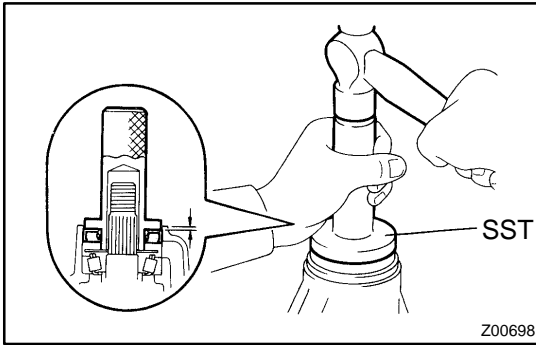

- (b) Using SST and a hammer, install a new oil seal.
SST 09554-3001 1
Oil seal drive in depth: 1.5 mm (0.059 in.)
- (c) Coat MP grease to the oil seal lip.

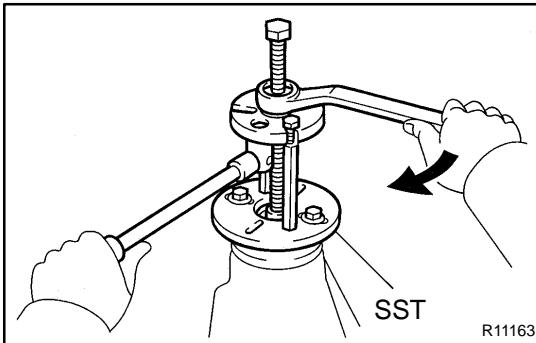

21. INSTALL COMPANION FLANGE

- (a) Using SST, install the companion flange.
SST 09950-30012 (09951-03010, 09953-03010,
09954-03010, 09955-03030, 09956-03020)
- (b) Coat the thread of a new nut with hypoid gear oil LSD.

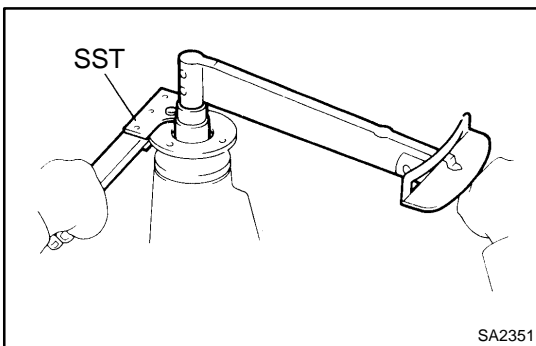

- (c) Using SST to hold the flange, tighten the nut.
SST 09330-00021
Torque: 108 N·m (1,100 kgf·cm, 80 ft·lbf)

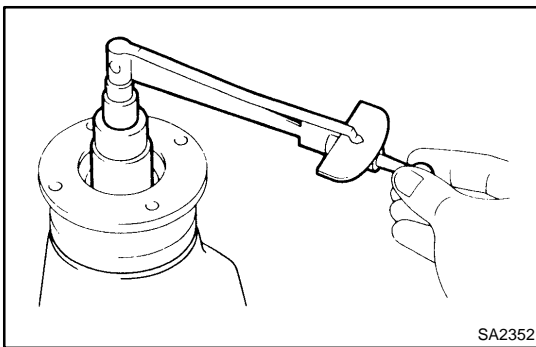

22. ADJUST DRIVE PINION PRELOAD

Using a torque wrench, measure the drive pinion preload using the backlash of the drive pinion and ring gear.

Preload (at starting):

New bearing

1.0 - 1.6 N·m (10 - 16 kgf·cm, 8.7 - 13.9 in.-lbf)

Reused bearing

0.5 - 0.8 N·m (5 - 8 kgf·cm, 4.3 - 6.9 in.-lbf)

If the preload is greater than the specification, replace the bearing spacer.

If the preload is less than the specification, retighten the nut a force of 13 N·m (130 kgf·cm, 9 ft·lbf) at a time until the specified preload is reached.

SST 09330-00021

Torque: 338 N·m (3,447 kgf·cm, 249 ft·lbf) or less

If the maximum torque is exceeded while retightening the nut, replace the bearing spacer and repeat the preload procedure. Do not loosen the pinion nut to reduce the preload.

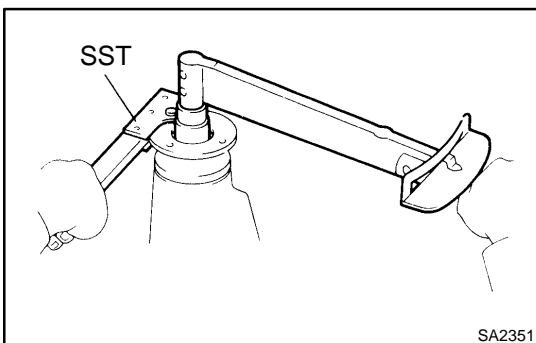

23. RECHECK TOTAL PRELOAD (See page SA-40)
24. RECHECK RING GEAR BACKLASH
(See page SA-40)
25. RECHECK TOOTH CONTACT BETWEEN RING GEAR
AND DRIVE PINION (See page SA-47)
26. CHECK RUNOUT OF COMPANION FLANGE (See
page SA-40)
27. STAKE DRIVE PINION NUT

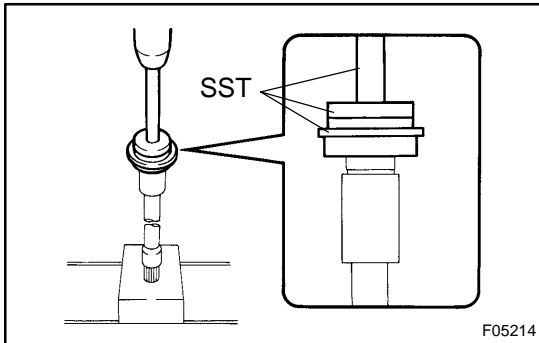

28. INSTALL SIDE GEAR BEARING

Using SST and a press, install the bearing to side gear shaft.
SST 09502-12010, 09950-60020 (09951-00730),
09950-70010 (09951-07100)

29. INSTALL DIFFERENTIAL TUBE ASSEMBLY

- (a) Clean surfaces with FIPG material attached to using gas-
oline or alcohol.
- (b) Apply FIPG to the differential tube.

FIPG:

**Part No. 08826 - 00090, THREE BOND 1281
or equivalent.**

HINT:

Install the differential tube within 10 minutes after applying
FIPG.

- (c) Install the differential tube with 4 bolts to the differential
tube.

Torque: 105 N·m (1,070 kgf·cm, 77 ft·lbf)

- (d) Install the side gear shaft.
- (e) Using a snap ring expander, install the snap ring.

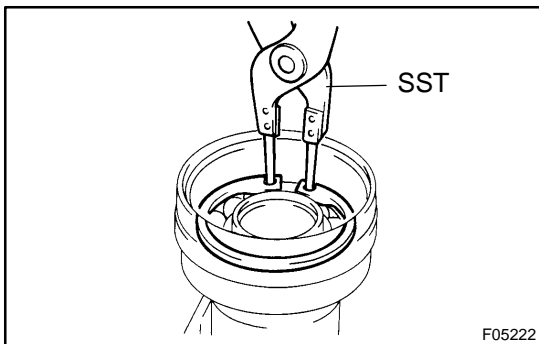

- (f) Using SST, install the snap ring.
SST 09350-30020 (09350-07060)

30. INSTALL SIDE GEAR SHAFT OIL SEALS

- (a) Coat the hypoid gear oil to a new oil seal periphery.

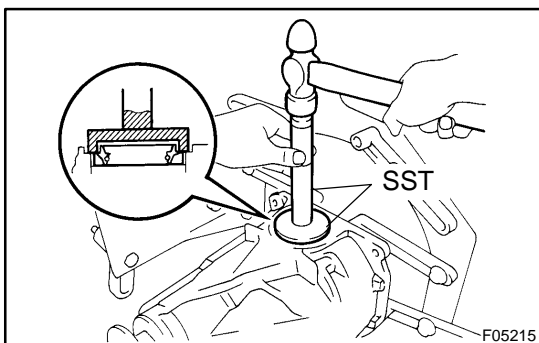

- (b) Using SST and a hammer, install 2 new oil seals.
SST 09550-00032, 09950-70010 (09951-07150)
- (c) Coat MP grease to the oil seal lip.

31. REMOVE DIFFERENTIAL CARRIER FROM OVER- HAUL STAND, ETC.

32. INSTALL DIFFERENTIAL CARRIER COVER

- (a) Install the oil deflector with 2 bolts to the carrier cover.
Torque: 7.3 N·m (74 kgf·cm, 64 in.-lbf)
- (b) Install the breather plug to the carrier cover.
- (c) Remove any old FIPG material and be careful not to drop oil on the contact surfaces of the differential carrier and carrier cover.
- (d) Clean surfaces with FIPG with material attached to using gasoline or alcohol.

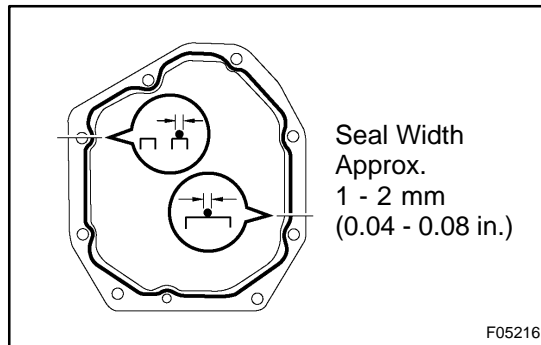

- (e) Apply FIPG to the carrier cover, as shown.

FIPG:

Part No. 08826-00090, THREE BOND 1281 or equivalent.

HINT:

Install the carrier cover within 10 minutes after applying FIPG.

- (f) Install the differential carrier cover with the 9 bolts.
Torque: 47 N·m (475 kgf·cm, 34 ft·lbf)

REMOVAL

1. REMOVE FRONT WHEELS
Torque: 131 N·m (1,340 kgf·cm, 97 ft·lbf)
2. REMOVE DRIVE SHAFTS (See page SA-26)

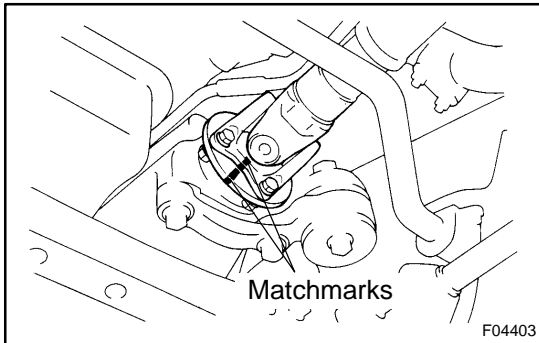

3. DISCONNECT FRONT PROPELLER SHAFT
 - (a) Place matchmarks on the propeller shaft and companion flange.
 - (b) Remove the 4 nuts, bolts, washers and disconnect the propeller shaft.
Torque: 80 N·m (820 kgf·cm, 59 ft·lbf)
 - (c) Support the propeller shaft securely.
4. DRAIN HYPOID GEAR OIL
Torque: 49 N·m (500 kgf·cm, 36 ft·lbf)

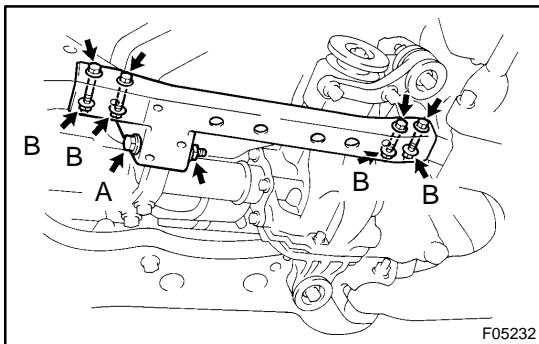

5. REMOVE NO. 3 FRAME CROSSMEMBER
Remove the 5 bolts, nuts, 4 washers and No. 3 frame crossmember.

Torque:

A: 186 N·m (1,900 kgf·cm, 137 ft·lbf)

B: 68 N·m (695 kgf·cm, 50 ft·lbf)

6. REMOVE FRONT DIFFERENTIAL CARRIER ASSEMBLY
 - (a) Support the front differential carrier assembly with a jack.
 - (b) Remove the bolt and disconnect the breather hose.
Torque: 17 N·m (173 kgf·cm, 13 ft·lbf)

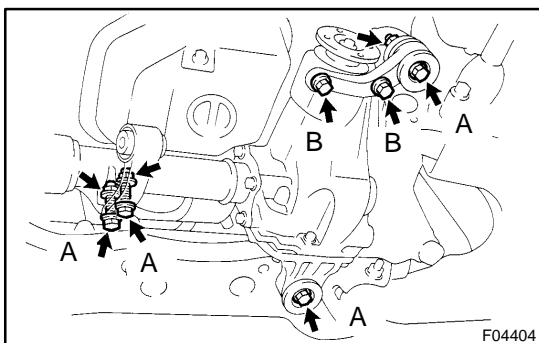

- (c) Remove the 3 nuts, 4 mount stoppers, 6 bolts, 2 differential supports and front differential carrier assembly.
Torque:
A: 186 N·m (1,900 kgf·cm, 137 ft·lbf)
B: 78 N·m (800 kgf·cm, 58 ft·lbf)

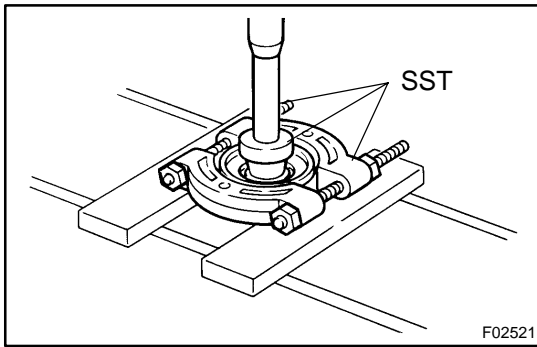

REPLACEMENT

REPLACE COMPANION FLANGE DUST DEFLECTOR

- (a) Using SST and a press, remove the dust deflector.
SST 09950-00020, 09950-60010 (09951-00400),
09950-70010 (09951-07100)

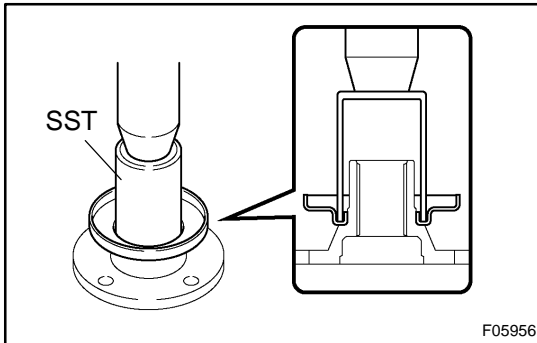

- (b) Using SST and a press, install a new dust deflector.
SST 09223-00010

FRONT DRIVE SHAFT COMPONENTS

SA14E-04

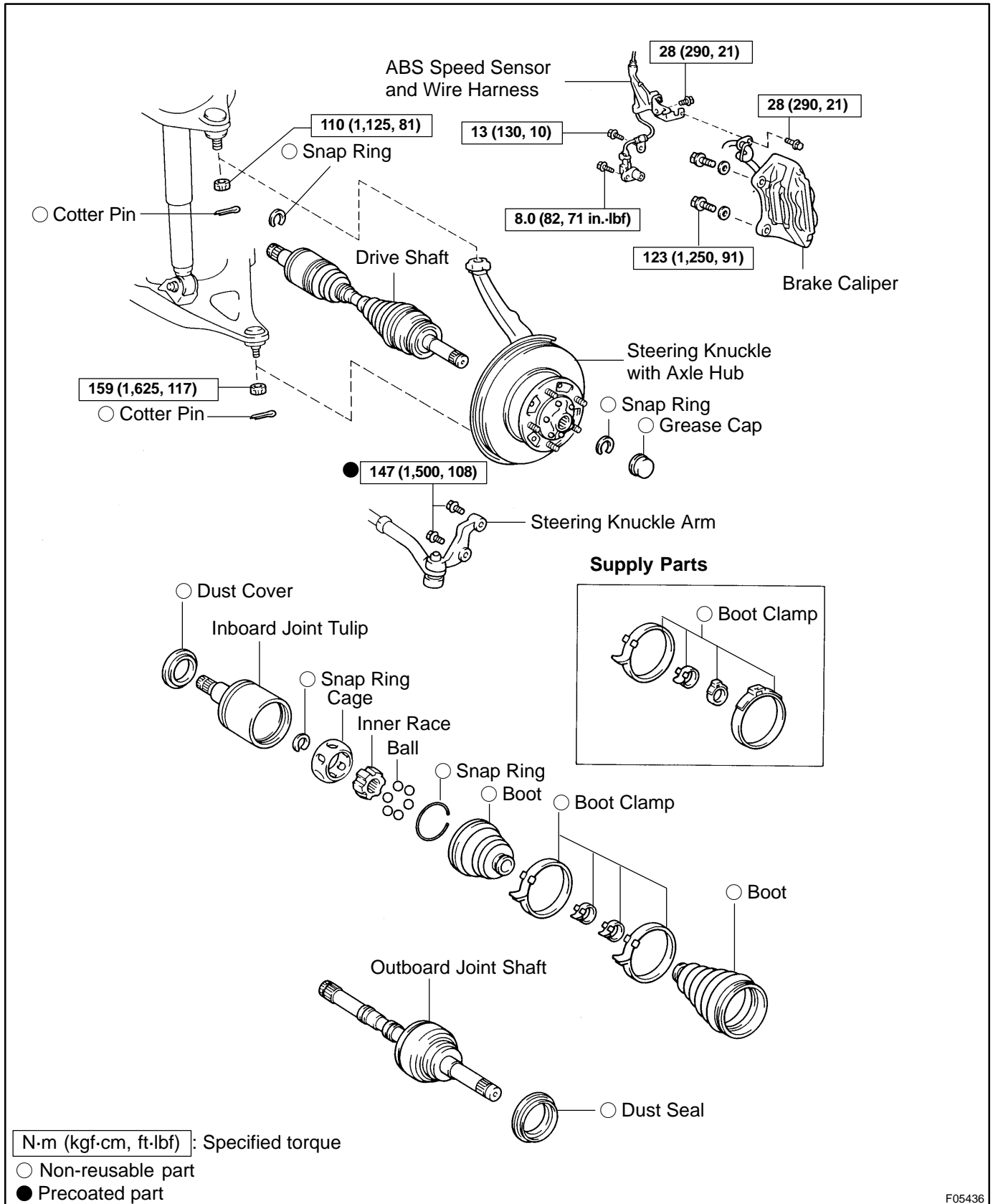

F05436

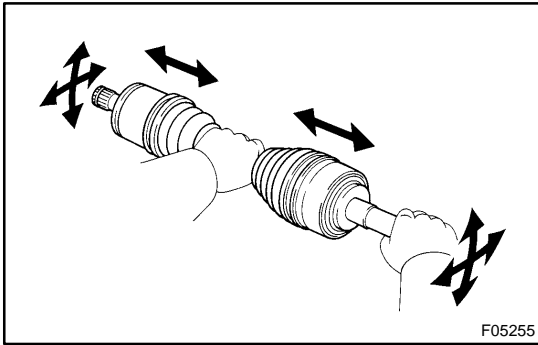

DISASSEMBLY

1. CHECK DRIVE SHAFT

- Check to see that there is no remarkable play in the outboard joint.
- Check to see that the inboard joint slides smoothly in the thrust direction.
- Check to see that there is no remarkable play in the radial direction of the inboard joint.
- Check the boots for damage.

2. UNSTAKE INBOARD JOINT BOOT CLAMPS

Using a screwdriver, unstake the 2 inboard joint boot clamps.

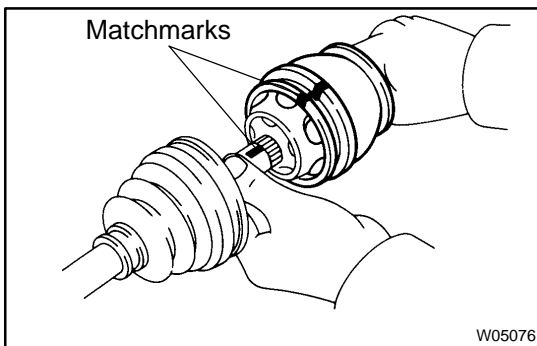

3. REMOVE INBOARD JOINT TULIP

- Place matchmarks on the inboard joint tulip and outboard joint shaft.

NOTICE:

Do not punch the marks.

- Using a screwdriver, remove the snap ring from the outboard joint shaft.
- Remove the inboard joint tulip from the outboard joint shaft.

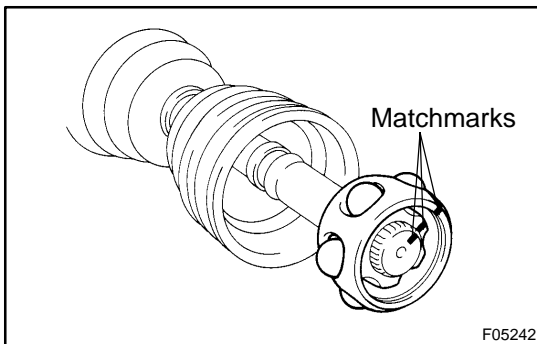

4. DISASSEMBLE INBOARD JOINT

- Place matchmarks on the outboard joint shaft, inner race and cage.

NOTICE:

Do not punch the marks.

- Remove the 6 balls.
- Slide the cage to the outboard joint side.
- Using a snap ring expander, remove the snap ring.
- Using a brass bar and hammer, remove the inner race.

NOTICE:

Be careful not to damage the inner race.

- Remove the cage.

5. REMOVE INBOARD JOINT BOOT AND 2 CLAMPS

6. REMOVE OUTBOARD JOINT BOOT CLAMPS

- Using a screwdriver, unstake the 2 outboard joint boot clamps.

HINT:

If the outboard joint boot clamps that have been replaced are installed to the drive shaft, use a side cutter or pliers to remove them.

- (b) Remove the 2 outboard joint boot clamps and outboard joint boot.

NOTICE:

Do not disassemble the outboard joint.

7. REMOVE DUST COVER

Using a screwdriver and hammer, remove the dust cover from the inboard joint tulip.

8. REMOVE DUST SEAL

Using a screwdriver and hammer, remove the dust seal from the outboard joint shaft.

INSTALLATION

Installation is in the reverse order of removal (See page [SA-26](#)).

HINT:

After installation, check the ABS speed sensor signal (See page [DI-505](#)).

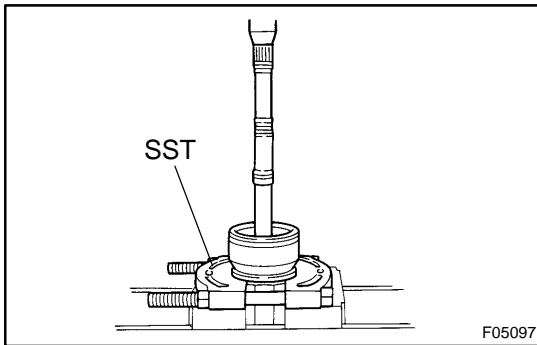

REASSEMBLY

1. INSTALL DUST SEAL

Using SST and a press, install a new dust seal to the outboard joint shaft.

SST 09950-00020

NOTICE:

Be careful not to damage the dust seal.

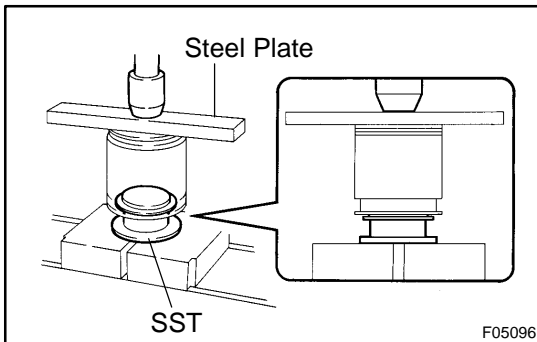

2. INSTALL DUST COVER

Using SST a steel plate and press, install a new dust cover.

SST 09316-2001 1

NOTICE:

Be careful not to damage the dust cover.

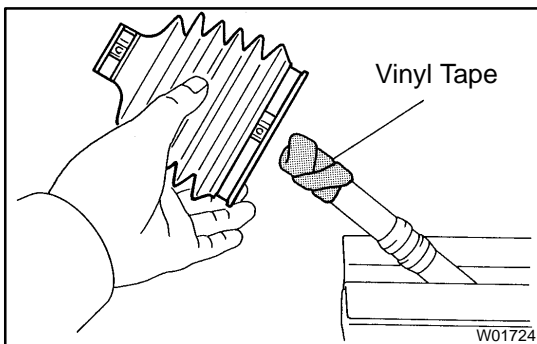

3. INSTALL OUTBOARD JOINT BOOT AND CLAMPS

(a) Place 2 new boot clamps to boot.

HINT:

Before installing the boot, wrap vinyl tape around the spline of the shaft to prevent damaging the boot.

(b) Temporarily install a new boot to the outboard joint shaft.

(c) Position the inside clamp onto the boot.

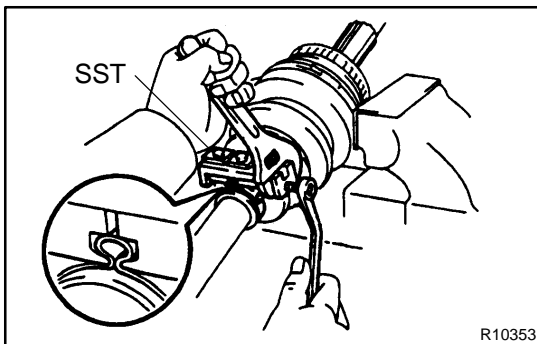

(d) Using SST, pinch the inside clamp.

SST 09521-24010

NOTICE:

Do not overtighten SST.

(e) Pack the outboard joint and boot with grease in the boot kit.

Grease capacity: 368 - 378 g (13.0 - 13.3 oz.)

(f) Position the outside clamp onto the boot.

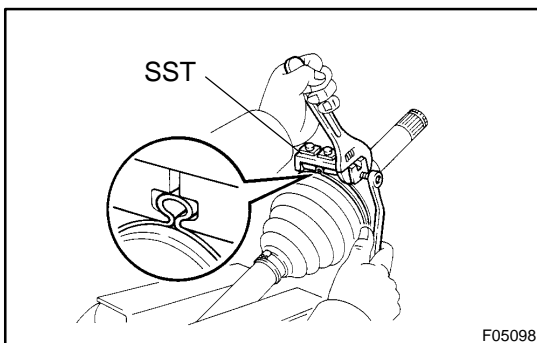

(g) Using SST, pinch the outside clamp.

SST 09521-24010

NOTICE:

Do not overtighten SST.

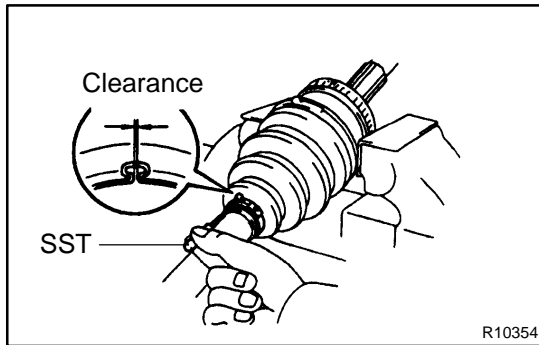

- (h) Using SST, adjust the clearance of the clamps.
SST 09240-00020

Clearance: 0.8 mm (0.031 in.)

4. TEMPORARILY INSTALL INBOARD JOINT BOOT AND CLAMPS

Temporarily install 2 new boot clamps and boot to the outboard joint shaft.

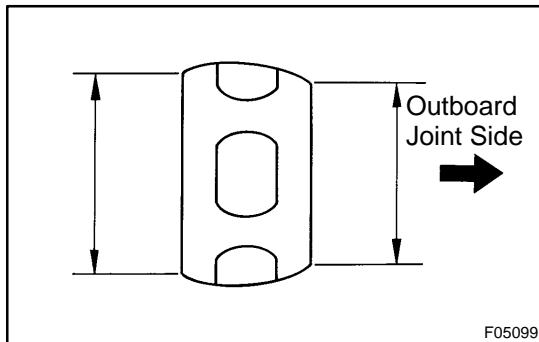

5. ASSEMBLE INBOARD JOINT

- (a) Install the cage to the outboard joint shaft.

NOTICE:

Insert the cage with its smaller inner diameter side facing to the outboard joint.

- (b) Align matchmarks placed before removal.
(c) Install the inner race.
(d) Using a snap ring expander, install a new snap ring.
(e) Align matchmarks placed before removal, and install the cage to the inner race.
(f) Install the 6 balls.

HINT:

Apply grease onto the balls to keep them from falling.

- (g) Pack the inboard joint tulip and boot with grease in the boot kit.

Grease capacity: 293 - 303 g (10.3 - 10.7 oz.)

- (h) Align matchmarks placed before removal, and install the inboard joint tulip to the outboard joint shaft.
(i) Install a new snap ring.
(j) Temporarily install the boot to the inboard joint tulip.
(k) Make sure that the boot is on the shaft groove.

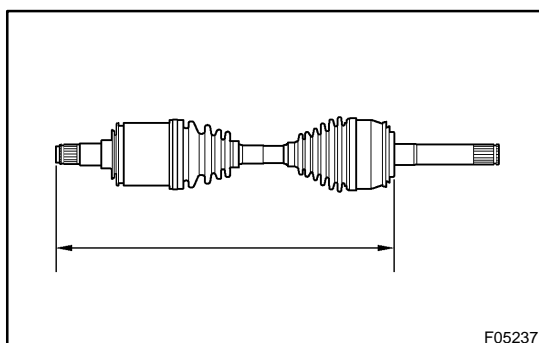

- (l) Make sure that the 2 boots are not stretched or contracted when the drive shaft is at standard length.

Drive shaft standard length:

573.9 ± 5.0 mm (22.594 ± 0.197 in.)

- (m) Using a screwdriver, bend the clamps and lock them.

6. CHECK DRIVE SHAFT (See page SA-29)

REMOVAL

1. REMOVE FRONT WHEEL

Torque: 131 N·m (1,340 kgf·cm, 97 ft·lbf)

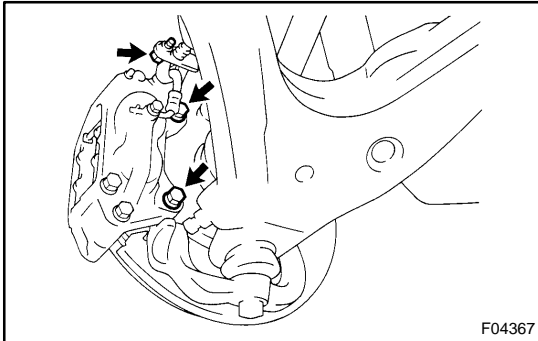

2. REMOVE BRAKE CALIPER

- (a) Remove the bolt and disconnect the flexible hose from the steering knuckle.

Torque: 28 N·m (290 kgf·cm, 21 ft·lbf)

- (b) Remove the 2 bolts, washers and brake caliper.

Torque: 123 N·m (1,250 kgf·cm, 91 ft·lbf)

- (c) Support the brake caliper securely.

3. REMOVE SNAP RING

- (a) Using a screwdriver and hammer, remove the grease cap from the flange.

- (b) Using snap ring pliers, remove the snap ring.

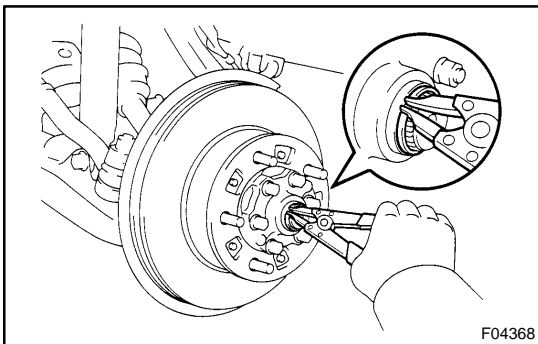

4. DISCONNECT ABS SPEED SENSOR AND WIRE HARNESS

Remove the 3 bolts and disconnect the ABS speed sensor and wire harness.

Torque:

A: 8.0 N·m (82 kgf·cm, 71 in.-lbf)

B: 13 N·m (130 kgf·cm, 10 ft·lbf)

C: 28 N·m (290 kgf·cm, 21 ft·lbf)

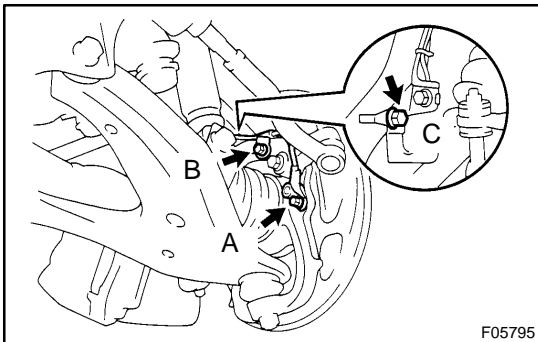

5. DISCONNECT STEERING KNUCKLE ARM

Remove the 2 bolts and disconnect the steering knuckle arm.

Torque: 147 N·m (1,500 kgf·cm, 108 ft·lbf)

HINT:

At the time of installation, please refer to the following items.

- Clean the threads of the 2 bolts and steering knuckle with toluene or trichloroethylene.

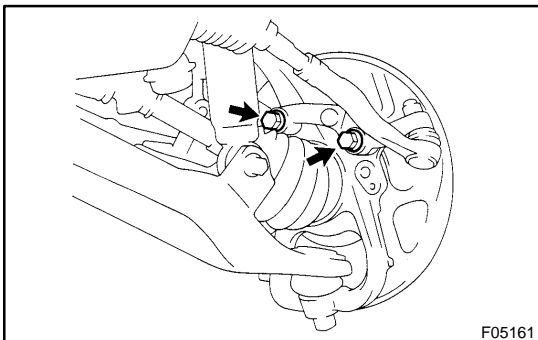

- Apply sealant to the 2 bolt threads.

Sealant:

**Part No. 08833-00070, THREE BOND 1324
or equivalent**

6. DISCONNECT STEERING KNUCKLE FROM LOWER SUSPENSION ARM

- (a) Remove the cotter pin and nut.

Torque: 159 N·m (1,625 kgf·cm, 117 ft·lbf)

HINT:

At the time of installation, if the holes for the cotter pin are not aligned, tighten the nut further up to 60°.

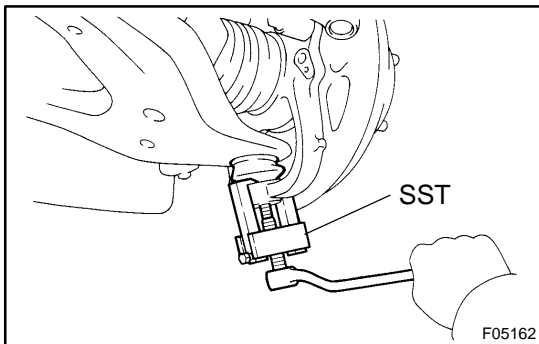

- (b) Using SST, disconnect the steering knuckle from the lower suspension arm.

SST 09628-6201 1

7. REMOVE STEERING KNUCKLE WITH AXLE HUB

- (a) Temporarily install the nut to the lower suspension arm.
(b) Support the lower suspension arm with a jack.
(c) Remove the cotter pin and nut.

Torque: 110 N·m (1,125 kgf·cm, 81 ft·lbf)

HINT:

At the time of installation, if the holes for the cotter pin are not aligned, tighten the nut further up to 60°.

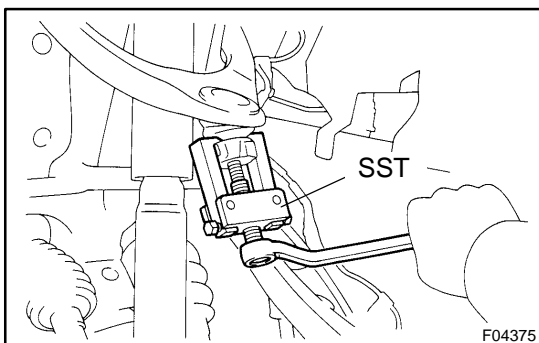

- (d) Using SST, disconnect the steering knuckle from the upper suspension arm.

SST 09628-6201 1

- (e) Remove the nut and steering knuckle with axle hub.

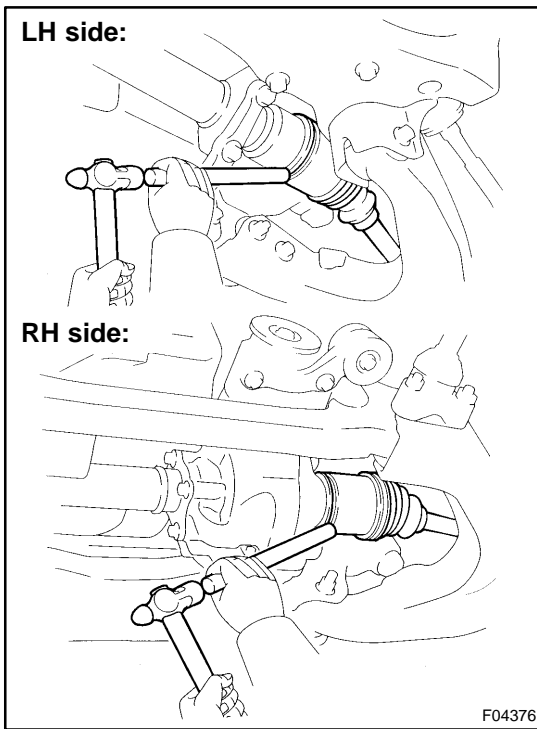

8. REMOVE DRIVE SHAFT

(a) Using a brass bar and hammer, remove the drive shaft.

NOTICE:

Be careful not to damage the boot, dust cover and oil seal.

(b) Using a screwdriver, remove the snap ring from the in-board joint tulip.

HINT:

At the time of installation, please refer to the following items.

- Coat the oil seal lip with MP grease.
- Before installation, set a new snap ring with opening side facing downward.
- After installation, check that the drive shaft cannot be pulled out by hand.

FRONT DIFFERENTIAL SIDE GEAR SHAFT OIL SEAL COMPONENTS

SA14J-04

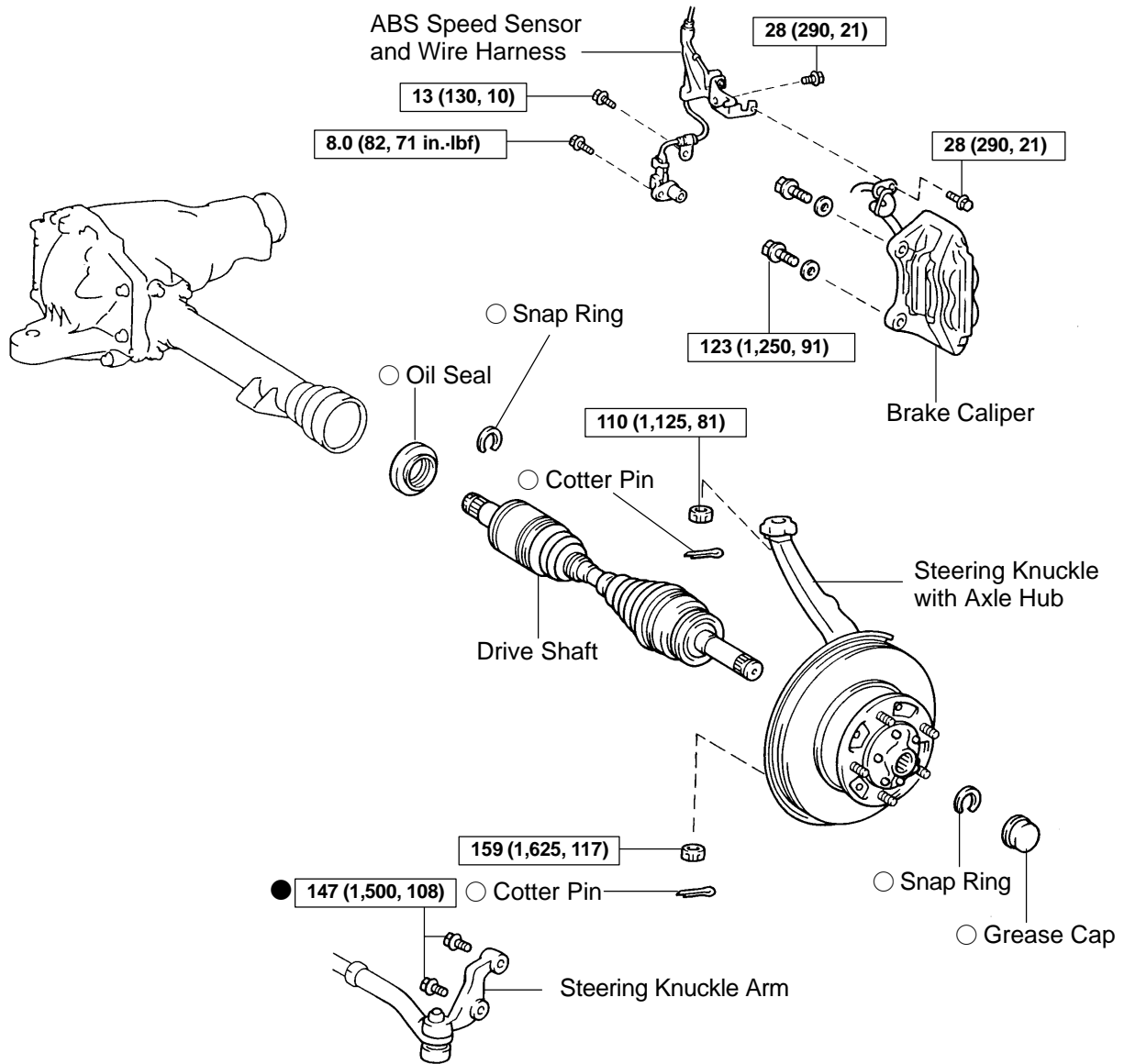

N-m (kgf·cm, ft·lbf) : Specified torque

○ Non-reusable part

● Precoated part

F05437

REPLACEMENT

1. REMOVE FRONT WHEELS
Torque: 131 N·m (1,340 kgf·cm, 97 ft·lbf)
2. REMOVE FRONT DRIVE SHAFT
(See page SA-26)

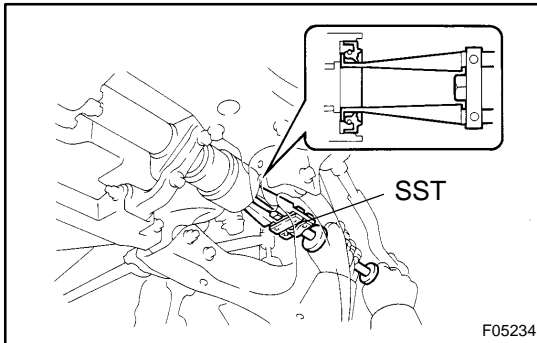

3. REPLACE OIL SEAL

- (a) Using SST, remove the oil seal.
SST 09308-00010
- (b) Coat the hypoid gear oil to a new oil seal periphery.

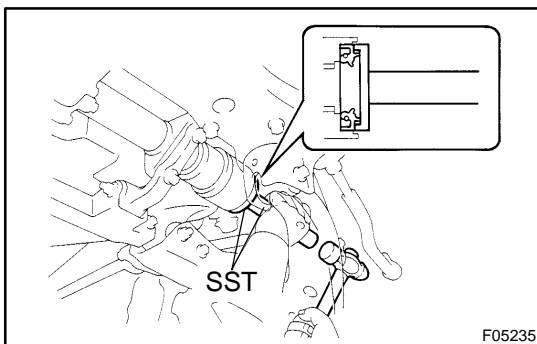

- (c) Using SST and a hammer, install the new oil seal.
SST 09550-00032, 09950-70010 (09951-07100)
- (d) Coat the MP grease to the oil seal lip.

4. INSTALL FRONT DRIVE SHAFT (See page SA-33)

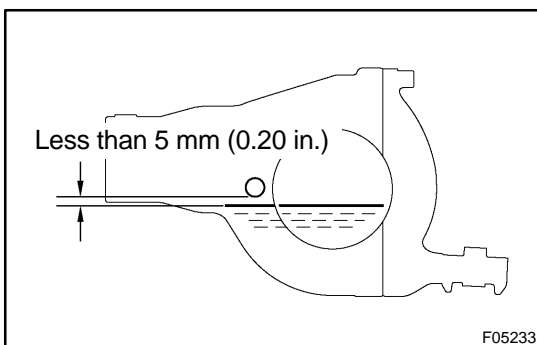

5. FILL DIFFERENTIAL WITH HYPOID GEAR OIL
Torque: 49 N·m (500 kgf·cm, 36 ft·lbf)
Oil type: Hypoid gear oil API GL-5
Recommended oil viscosity:
Above -18°C (0°F) SAE 90
Below -18°C (0°F) SAE 80W-90 or 80W
Capacity: 1.70 liters (1.80 US qts, 1.50 Imp.qts)

FRONT LOWER SUSPENSION ARM COMPONENTS

SA154-02

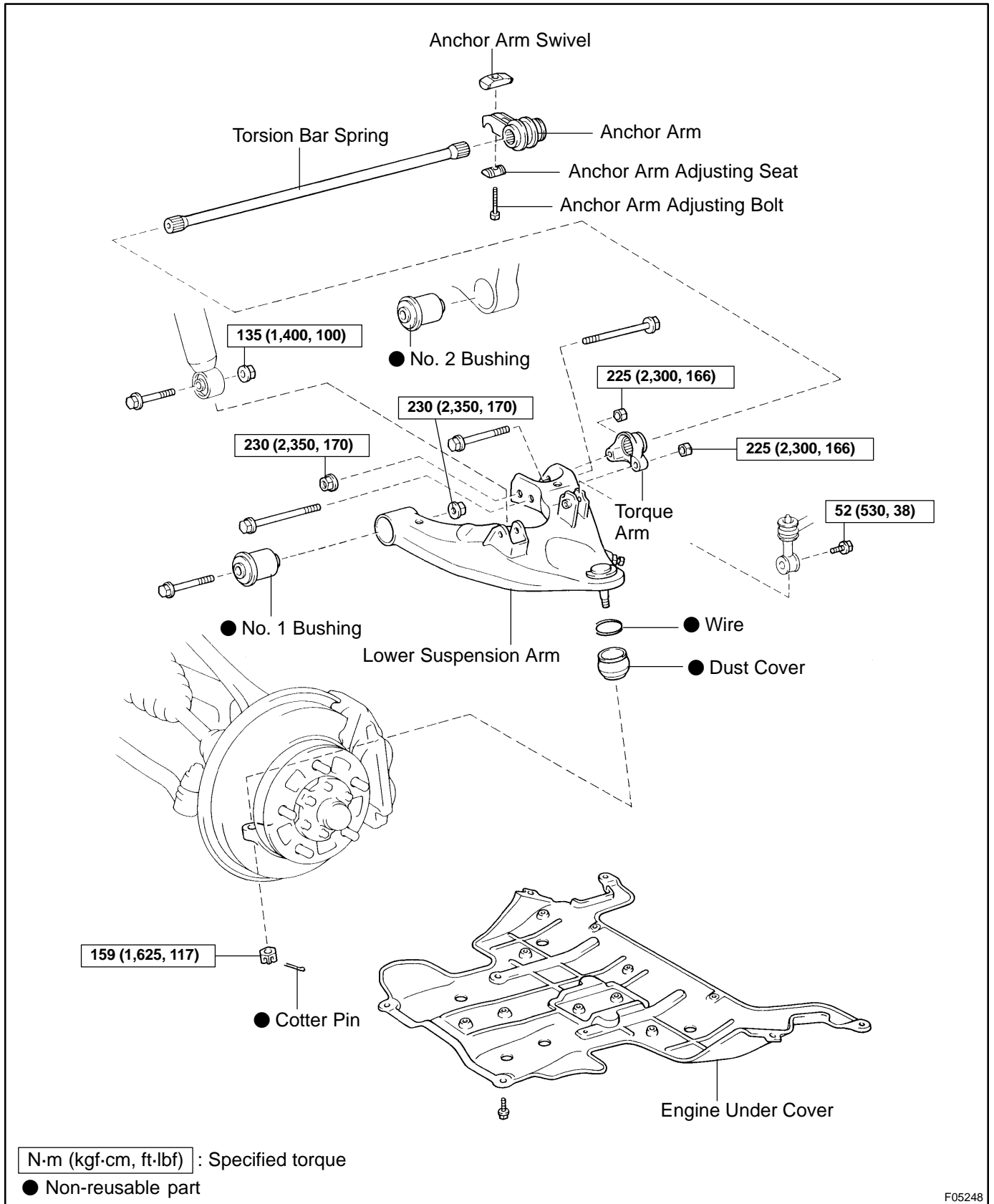

F05248

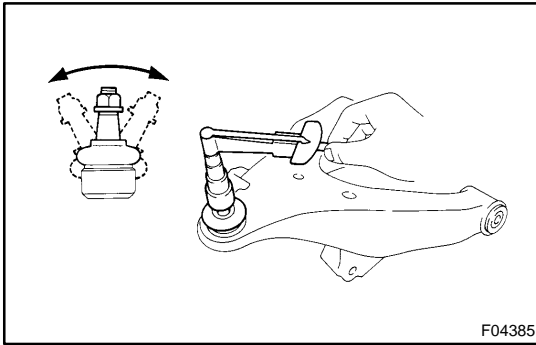

INSPECTION

INSPECT LOWER SUSPENSION ARM BALL JOINT FOR ROTATION CONDITION

- (a) As shown in the illustration, flip the ball joint stud back and forth 5 times, before installing the nut.
- (b) Using a torque wrench, turn the nut continuously one turn per 3 - 5 seconds and take the torque reading on the 5th turn.

Turning torque:

0.29 - 2.94 N·m (3 - 30 kgf·cm, 2.6 - 26 in.-lbf)

INSTALLATION

Installation is in the reverse order of removal (See page [SA-75](#)).

HINT:

After installation, check the front wheel alignment (See page [SA-6](#)).

REMOVAL

1. REMOVE FRONT WHEEL
Torque: 131 N·m (1,340 kgf·cm, 97 ft·lbf)
2. REMOVE ENGINE UNDER COVER
3. REMOVE FRONT TORSION BAR SPRING
(See page SA-66)

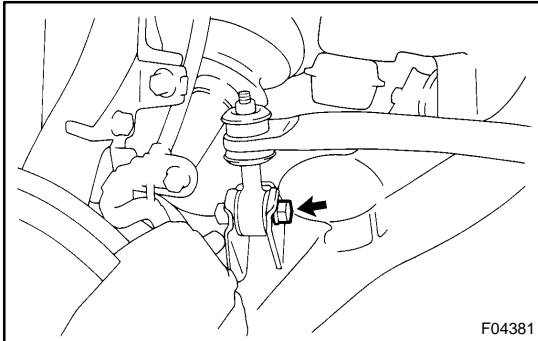

4. DISCONNECT STABILIZER BAR LINK FROM LOWER SUSPENSION ARM

Remove the bolt and disconnect the stabilizer bar link from the lower suspension arm.

Torque: 52 N·m (530 kgf·cm, 38 ft·lbf)

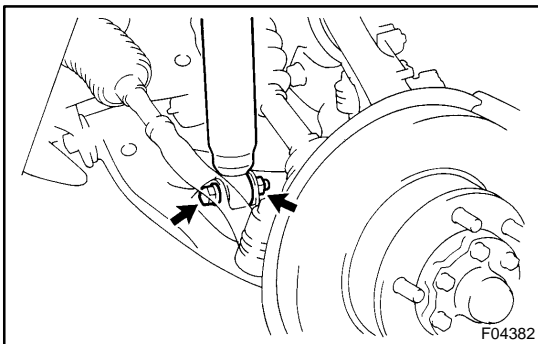

5. DISCONNECT SHOCK ABSORBER FROM LOWER SUSPENSION ARM

Remove the nut, bolt and disconnect the shock absorber from the lower suspension arm.

Torque: 135 N·m (1,400 kgf·cm, 100 ft·lbf)

6. DISCONNECT STEERING KNUCKLE FROM LOWER SUSPENSION ARM

(a) Remove the cotter pin and nut.

Torque: 159 N·m (1,625 kgf·cm, 117 ft·lbf)

(b) Using SST, disconnect the steering knuckle from the lower suspension arm.

SST 09628-6201 1

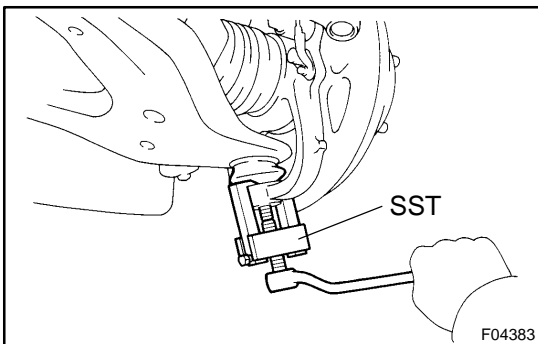

7. REMOVE LOWER SUSPENSION ARM

Remove the 2 nuts, 3 bolts and lower suspension arm.

Torque: 230 N·m (2,350 kgf·cm, 170 ft·lbf)

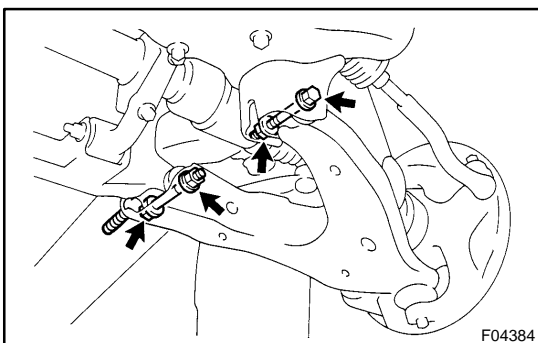

REPLACEMENT

1. REPLACE NO. 1 BUSHING

- (a) Using a chisel and hammer, pry up the flange of the No. 1 bushing.

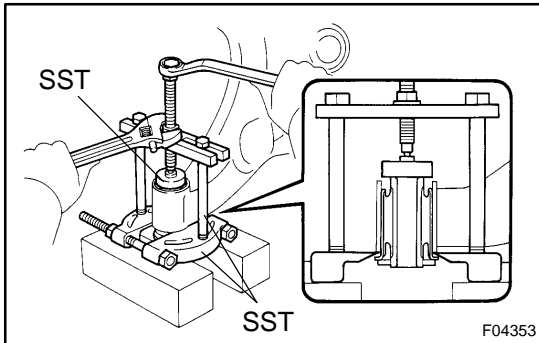

- (b) Using SST, remove the No. 1 bushing.
SST 09710-30021 (09710-03101),
09950-00020, 09950-00030,
09950-4001 1 (09957-04010)

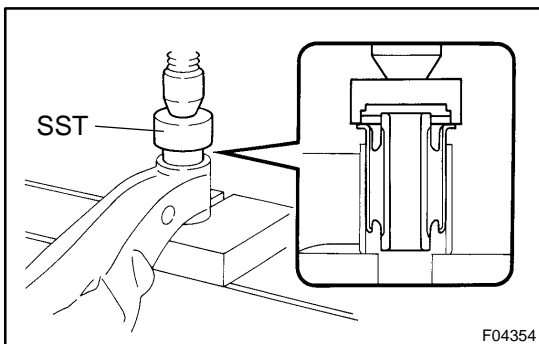

- (c) Using SST and a press, install a new No. 1 bushing.
SST 09726-36010

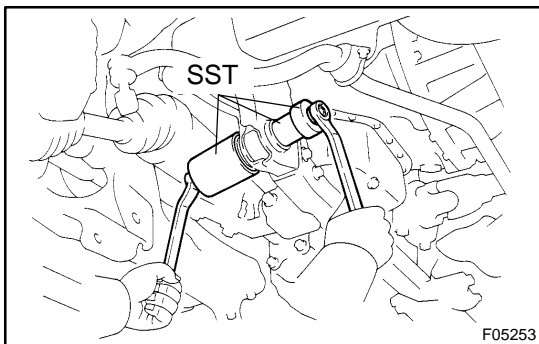

2. REPLACE NO. 2 BUSHING

- (a) Using SST, remove the No. 2 bushing.
SST 09710-22021 (09710-01071),
09726-3501 1 (09726-05021),
09830-36010

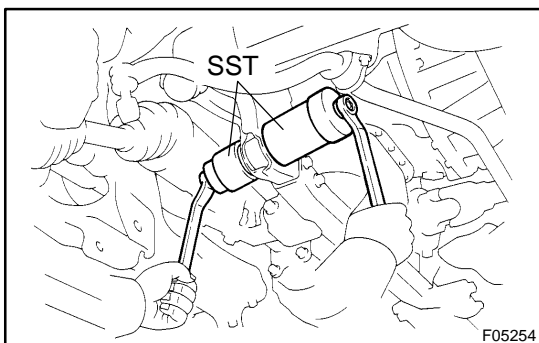

- (b) Using SST, install a new No. 2 bushing.
SST 09631-32020, 09830-36010

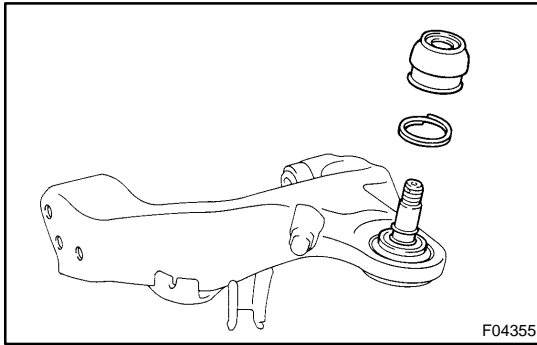
**3. REPLACE DUST COVER**

- (a) Remove the wire and dust cover.
- (b) Coat the ball joint with grease in the boot kit.
- (c) Install a new dust cover and wire.

FRONT SHOCK ABSORBER COMPONENTS

SA14R-02

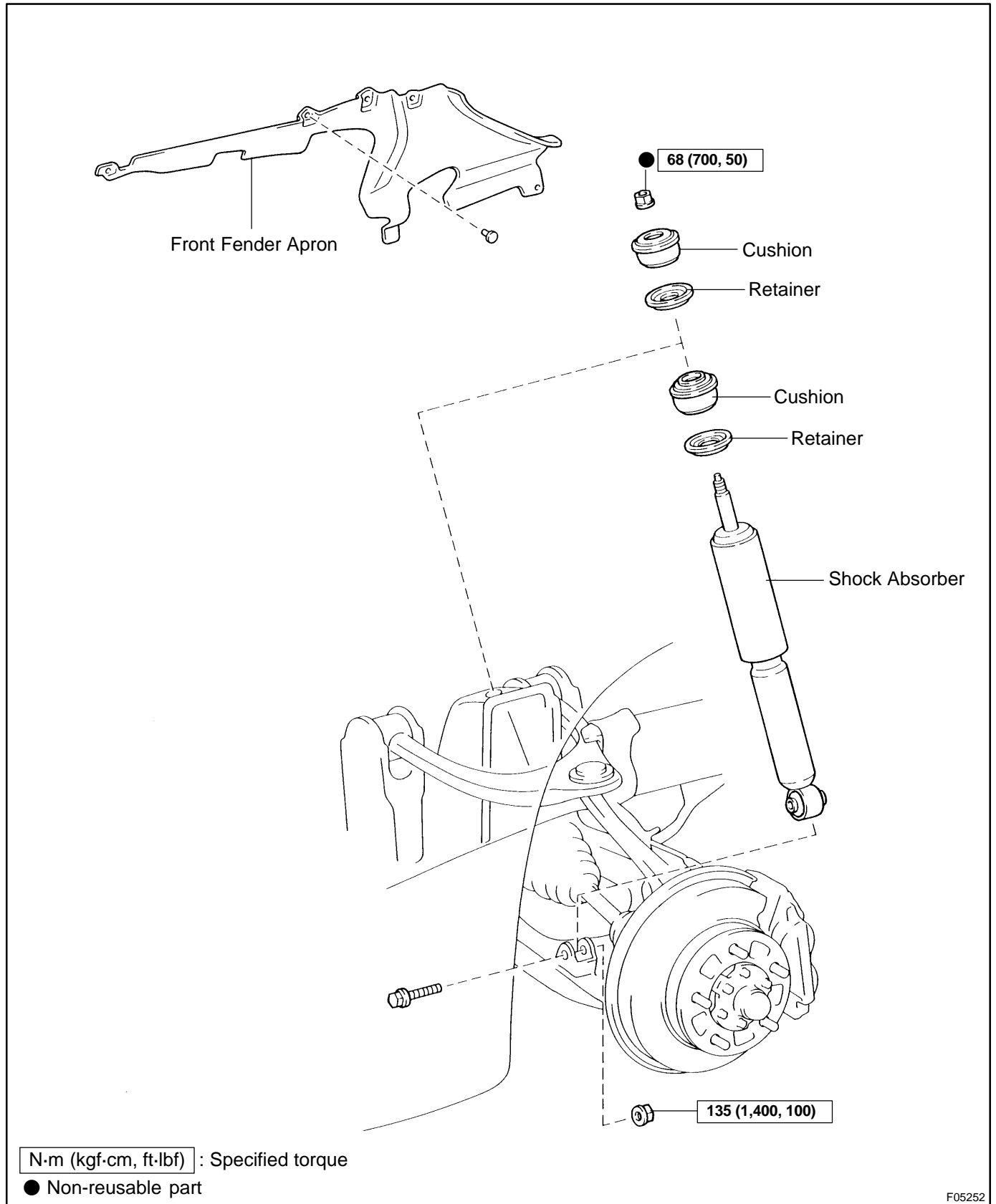

F05252

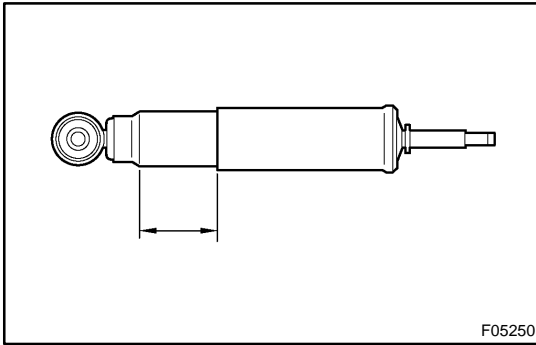

DISPOSAL

DISCARD SHOCK ABSORBER

Before discarding the shock absorber, drill a hole of 2 - 3 mm (0.079 - 0.118 in.) in diameter at the location shown in the illustration to discharge the gas inside.

NOTICE:

- When drilling, chips may fly out, work carefully.
- The gas is colorless, odorless and non-poisonous.

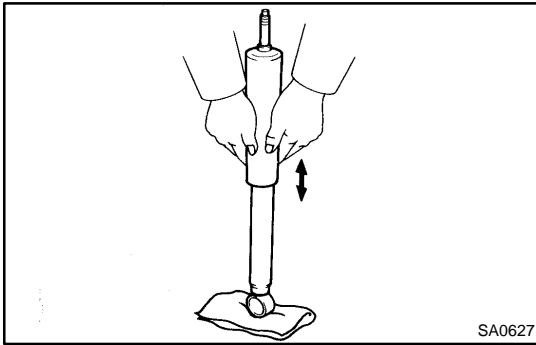

INSPECTION

INSPECT SHOCK ABSORBER

Compress and extend the shock absorber rod and check that there is no abnormal resistance or unusual operation sounds. If there is any abnormality, replace the shock absorber with a new one.

NOTICE:

When disposing the shock absorber, see **DISPOSAL** on page [SA-63](#) .

INSTALLATION

Installation is in the reverse order of removal (See page [SA-61](#)).

REMOVAL

1. REMOVE FRONT WHEEL
Torque: 131 N·m (1,340 kgf·cm, 97 ft·lbf)
2. REMOVE FRONT FENDER APRON

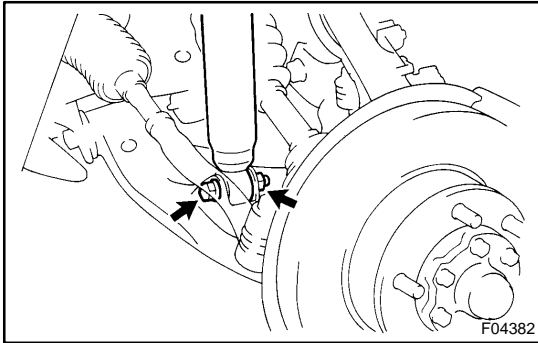

3. REMOVE SHOCK ABSORBER

- (a) Remove the bolt, nut and disconnect the shock absorber from the lower suspension arm.

Torque: 135 N·m (1,400 kgf·cm, 100 ft·lbf)

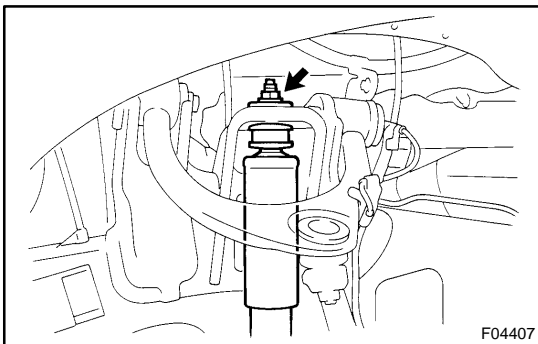

- (b) While holding the piston rod, remove the nut, cushion, retainer and shock absorber.

Torque: 68 N·m (700 kgf·cm, 50 ft·lbf)

- (c) Remove the cushion and retainer from the shock absorber.

FRONT STABILIZER BAR COMPONENTS

SA159-02

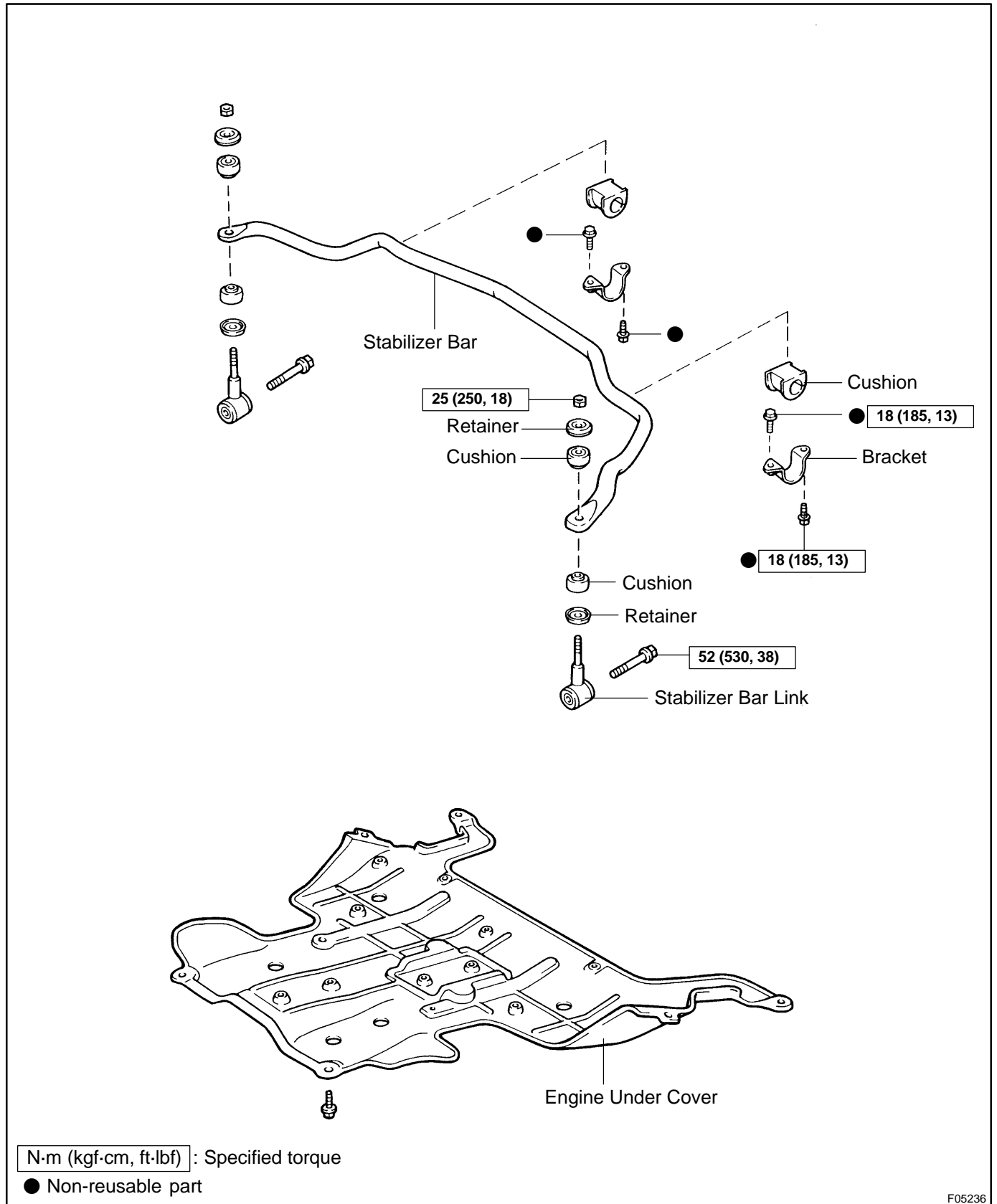

F05236

INSTALLATION

Installation is in the reverse order of removal (See page [SA-81](#)).

REMOVAL

1. REMOVE ENGINE UNDER COVER

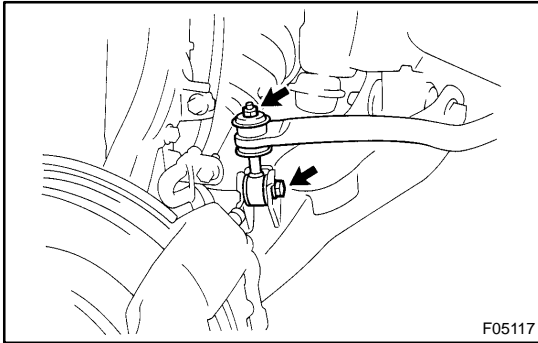

2. REMOVE LH AND RH STABILIZER BAR LINKS

- (a) Remove the nut, bolt, 2 retainers, 2 cushions and stabilizer bar link.

Torque:

Bolt: 52 N·m (530 kgf-cm, 38 ft-lbf)

Nut: 25 N·m (250 kgf-cm, 18 ft-lbf)

- (b) Employ the same manner described above to the other side.

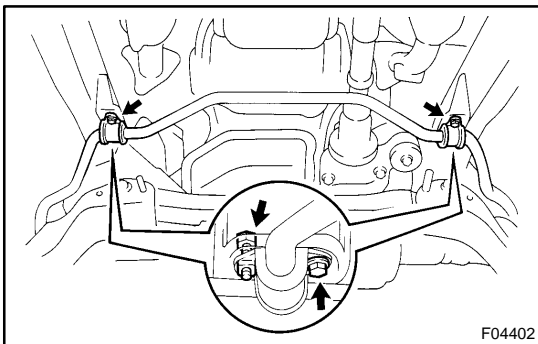

3. REMOVE STABILIZER BAR

- (a) Remove the 4 bolts, 2 brackets and 2 cushions.

Torque: 18 N·m (185 kgf-cm, 13 ft-lbf)

- (b) Remove the stabilizer bar.

FRONT TORSION BAR SPRING COMPONENTS

SA14W-02

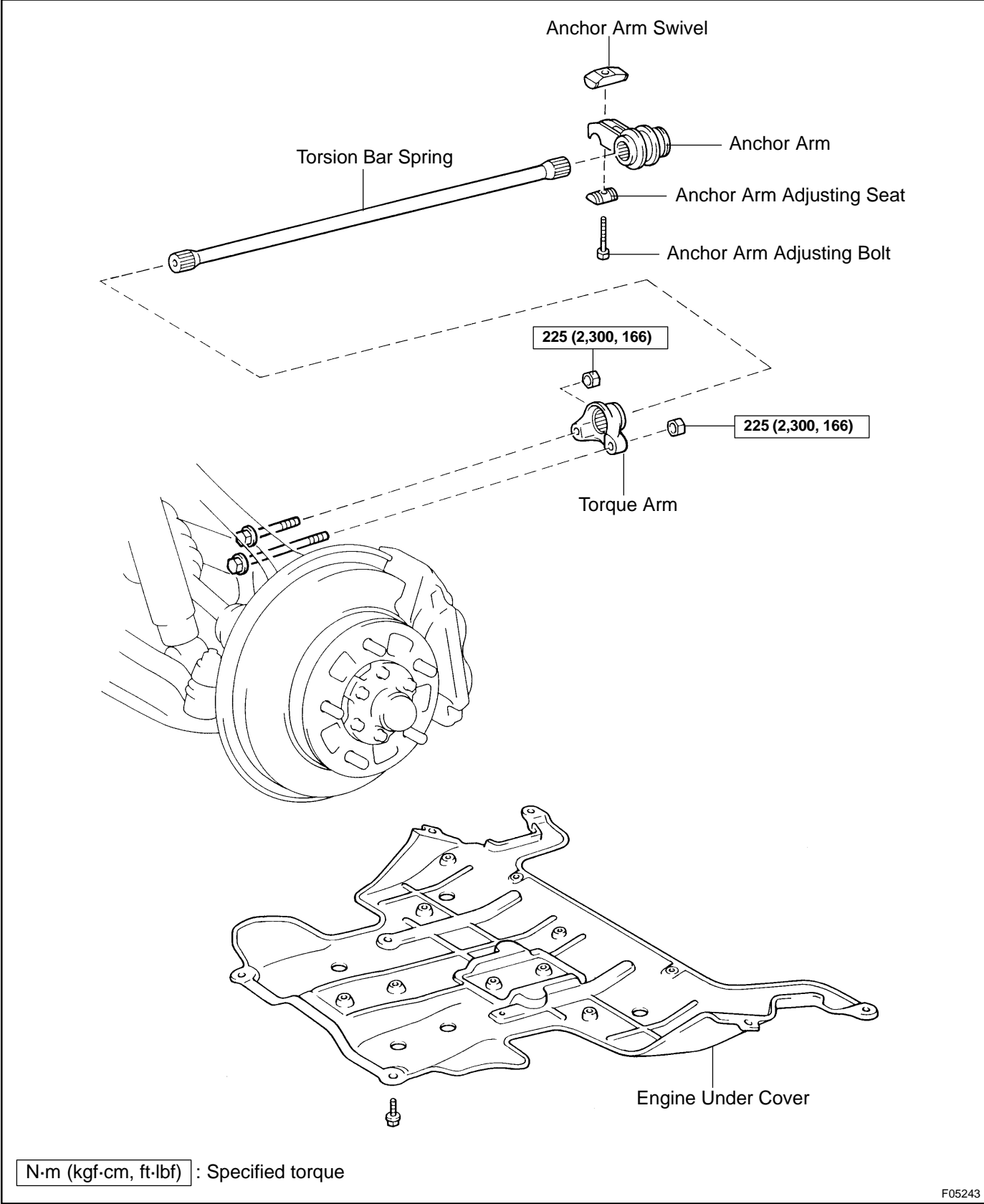

F05243

INSTALLATION

1. INSTALL TORQUE ARM

Install the bolt, torque arm and 2 nuts.

Torque: 225 N·m (2,300 kgf·cm, 166 ft·lbf)

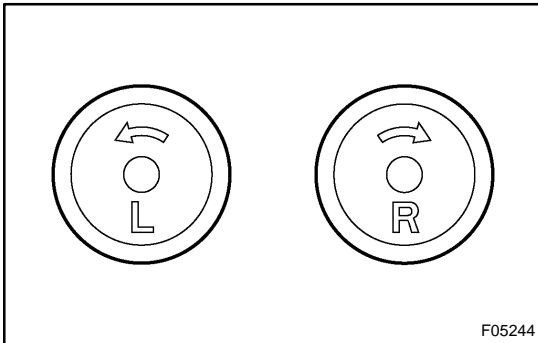

2. INSTALL TORSION BAR SPRING WITH ANCHOR ARM

HINT:

- There are right and left matchmarks on the rear end of the torsion bar springs.
- Apply a light coat of MP grease to the spline of the torsion bar springs.

(a) New torsion bar spring:

Install a new torsion bar spring and anchor arm.

- (1) Install the anchor arm to a new torsion bar spring.
- (2) Install the torsion bar spring with the anchor arm to the torque arm.
- (3) Install the anchor arm adjusting seat, anchor arm swivel and anchor arm adjusting bolt.

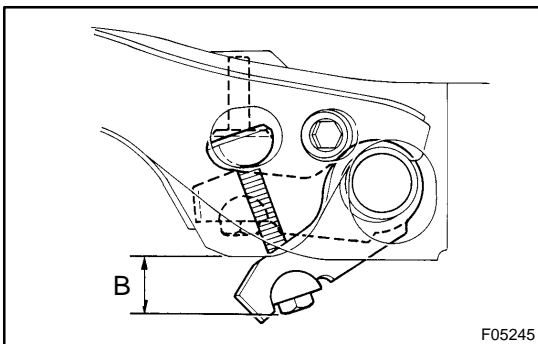

- (4) Check that the length of anchor arm adjusting bolt end is almost same as dimension "B" measured when the torsion bar was removed.

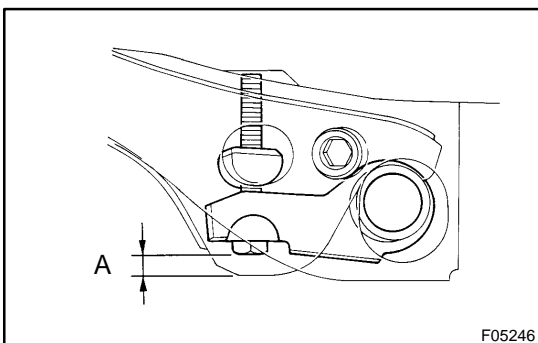

- (5) Tighten the anchor arm adjusting bolt so that the dimension "A" is within the specified value in the table below.

Reference:

LH	8 - 25 mm (0.315 - 0.984 in.)
RH	2 - 18 mm (0.079 - 0.709 in.)

(b) Reused torsion bar spring:

Install the torsion bar spring and anchor arm.

- (1) Align matchmarks on the torsion bar spring and anchor arm and install them.
- (2) Align matchmarks on the torsion bar spring and torque arm and install them.

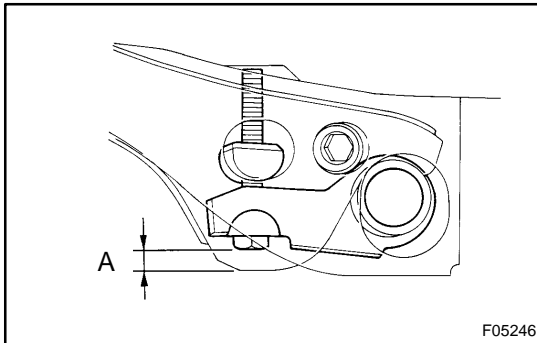

- (3) Tighten the anchor arm bolt adjusting so that the dimension "A" is almost same as the dimension measured when the torsion bar spring was removed.

3. INSTALL ENGINE UNDER COVER

4. INSTALL FRONT WHEEL

Torque: 131 N·m (1,340 kgf·cm, 97 ft·lbf)

5. CHECK VEHICLE HEIGHT (See page SA-6)

HINT:

After stabilizing the suspension, adjust the vehicle height by turning the anchor arm bolt.

REMOVAL

1. REMOVE FRONT WHEEL
2. REMOVE ENGINE UNDER COVER

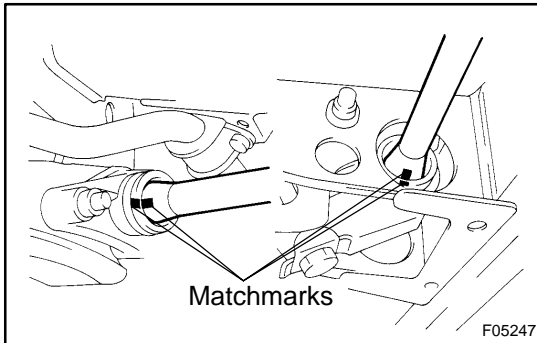

3. REMOVE TORSION BAR SPRING WITH ANCHOR ARM

- (a) Place matchmarks on the torsion bar spring, anchor arm and torque arm.

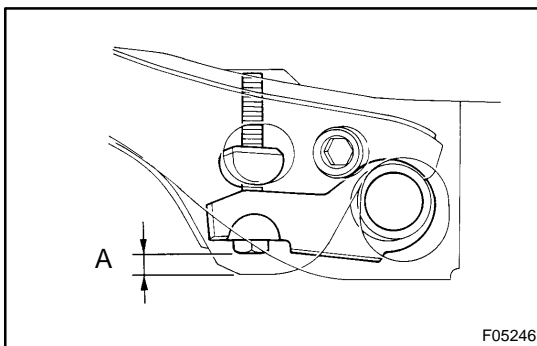

- (b) Measure the dimension "A" between the anchor arm adjusting bolt end and the frame as shown.

HINT:

Use the measurement for a reference when installing the anchor arm.

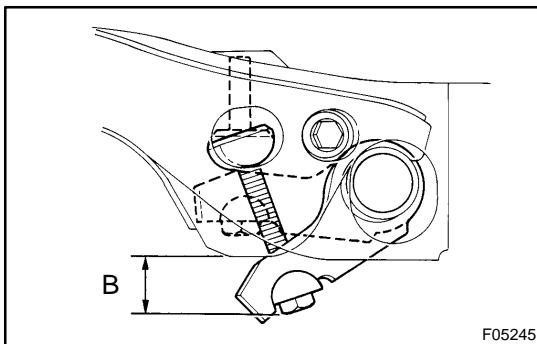

- (c) Loosen the anchor arm bolt until the spring tension is free and measure the anchor arm bolt "B".

HINT:

Use the measurement for a reference when installing the anchor arm.

- (d) Remove the anchor arm adjusting bolt, anchor arm swivel and anchor arm adjusting seat.
- (e) Remove the torsion bar spring with the anchor arm.
- (f) Remove the anchor arm from the torsion bar spring.

4. REMOVE TORQUE ARM

Remove the 2 nuts, bolt and torque arm.

FRONT UPPER SUSPENSION ARM COMPONENTS

SA14Z-02

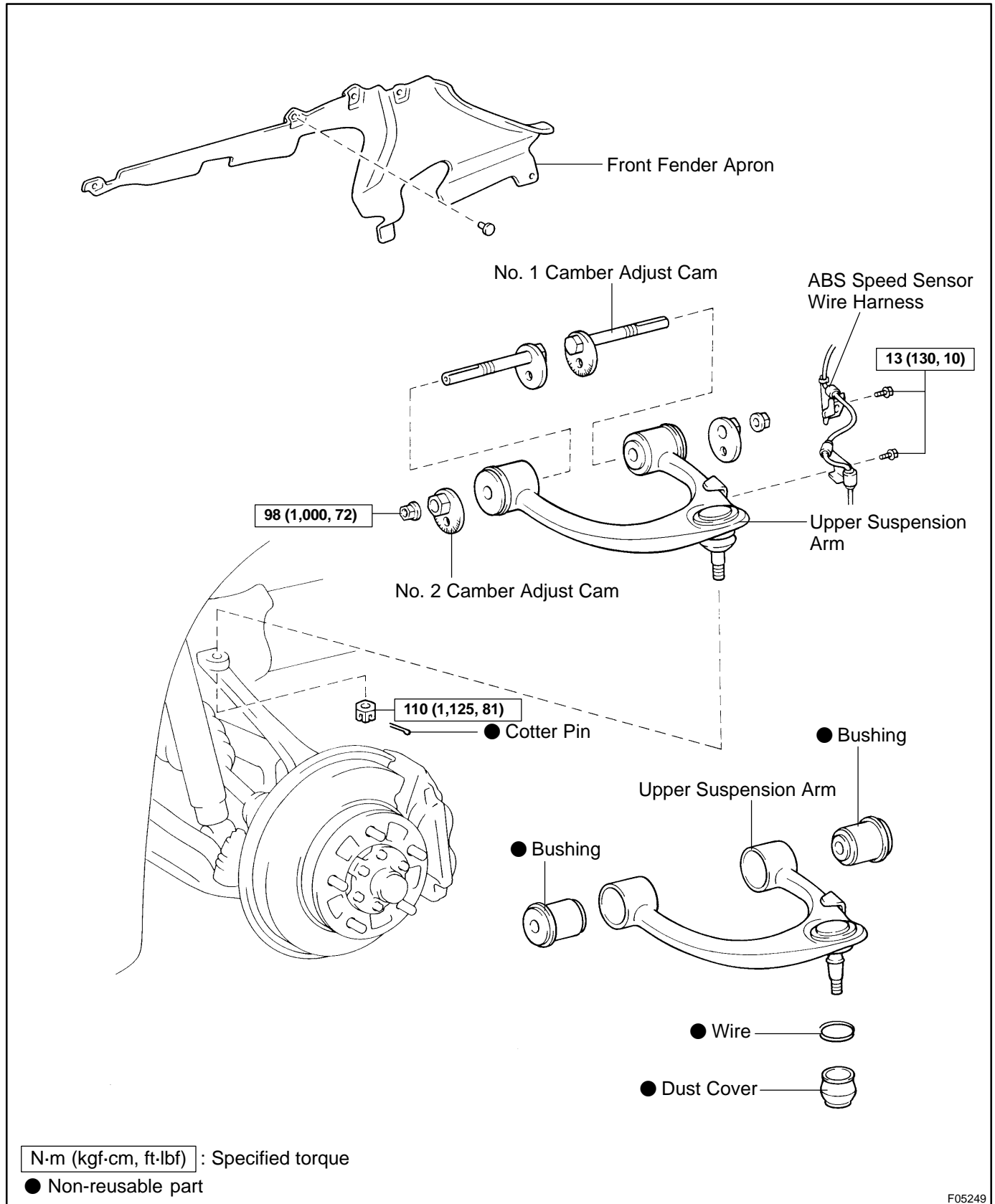

F05249

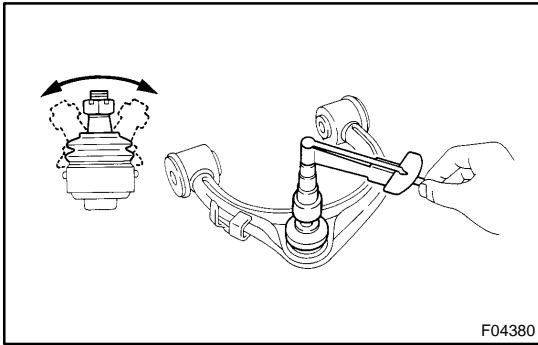

INSPECTION

INSPECT UPPER SUSPENSION ARM BALL JOINT FOR ROTATION CONDITION

- (a) As shown in the illustration, flip the ball joint stud back and forth 5 times, before installing the nut.
- (b) Using a torque wrench, turn the nut continuously one turn per 3 - 5 seconds and take the torque reading on the 5th turn.

Turning torque:

1.0 - 4.4 N·m (10 - 45 kgf·cm, 8.9 - 39 in.-lbf)

INSTALLATION

Installation is in the reverse order of removal (See page [SA-70](#)).

HINT:

After installation, check the front wheel alignment (See page [SA-6](#)).

REMOVAL

1. REMOVE FRONT WHEEL
Torque: 131 N·m (1,340 kgf·cm, 97 ft·lbf)
2. REMOVE FRONT FENDER APRON

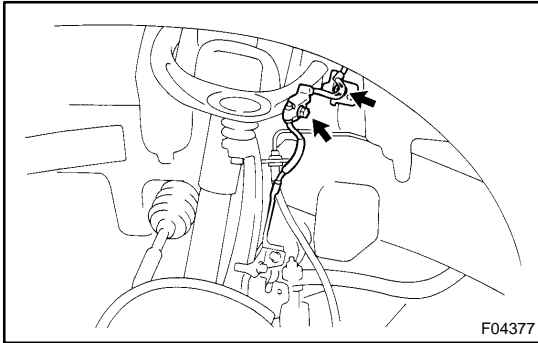

3. DISCONNECT ABS SPEED SENSOR WIRE HARNESS
Remove the 2 bolts and disconnect the ABS speed sensor wire harness.

Torque: 13 N·m (130 kgf·cm, 10 ft·lbf)

4. DISCONNECT STEERING KNUCKLE FROM UPPER SUSPENSION ARM

- (a) Support the lower suspension arm with a jack.
- (b) Remove the cotter pin and nut.

Torque: 110 N·m (1,125 kgf·cm, 81 ft·lbf)

HINT:

At the time of installation, if the holes for the cotter pin are not aligned, tighten the nut further up to 60°.

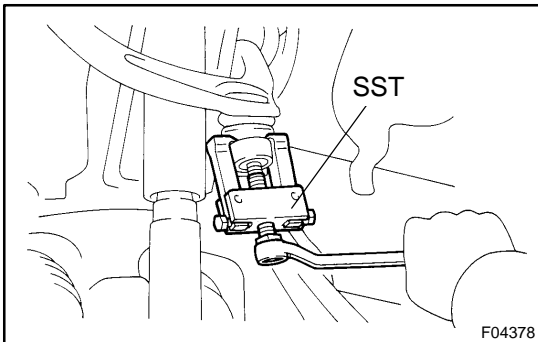

- (c) Using SST, disconnect the steering knuckle from the upper suspension arm.
SST 09628-6201 1

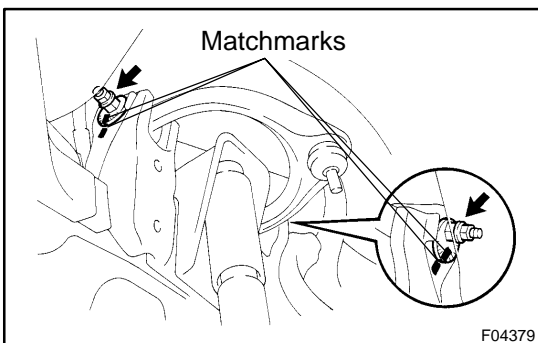

5. REMOVE UPPER SUSPENSION ARM
- (a) Place matchmarks on the front and rear No. 2 adjust cams and body.
- (b) Remove the 2 nuts, No. 1 and No. 2 camber adjust cams and upper suspension arm.

Torque: 98 N·m (1,000 kgf·cm, 72 ft·lbf)

HINT:

At the time of installation, after stabilizing the suspension, torque the nuts.

REPLACEMENT

1. REPLACE BUSHING

- (a) Using a chisel and hammer, pry up the flange of the bushing.

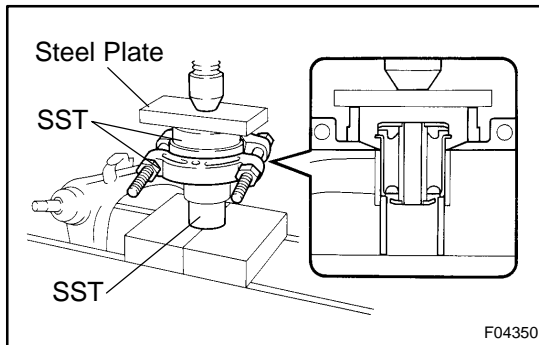

- (b) Using SST, a steel plate and press, remove the bushing.
SST 09527-1701 1, 09710-28021 (09710-08031),
09950-00020

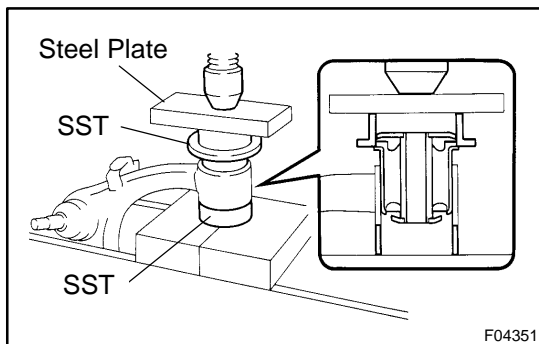

- (c) Using SST, a steel plate and press, install a new bushing.
SST 09316-2001 1, 09710-28012 (09710-07062)

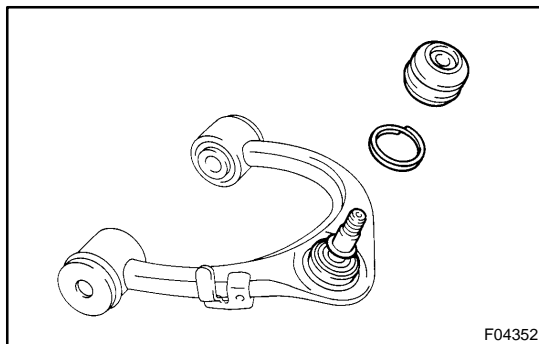

2. REPLACE DUST COVER

- (a) Remove the wire and dust cover.
(b) Coat the ball joint with grease in the boot kit.
(c) Install a new dust cover and wire.

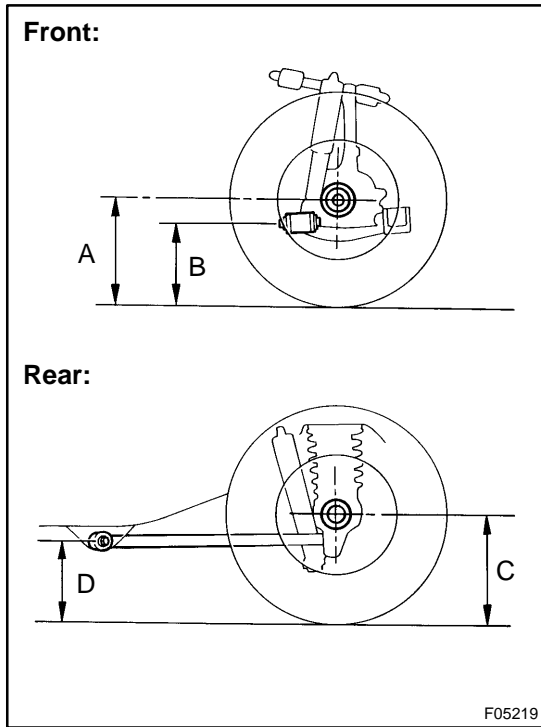

FRONT WHEEL ALIGNMENT INSPECTION

SA142-03

1. MEASURE VEHICLE HEIGHT

Vehicle height:

Front	A - B: 71 mm (2.795 in.)
Rear	C - D: 51 mm (2.008 in.)

Measuring points:

A: Ground clearance of spindle center

B: Ground clearance of lower suspension arm front bolt center

C: Ground clearance of rear axle shaft center

D: Ground clearance of lower control arm front bolt center

NOTICE:

Before inspecting the wheel alignment, adjust the vehicle height to the specified value.

If the vehicle height is not the specified value, try to adjust it by pushing down on or lifting the body.

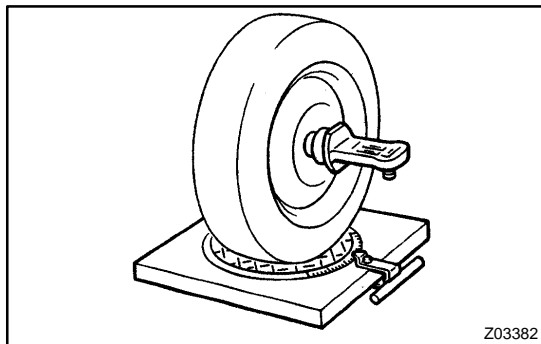

2. INSTALL CAMBER-CASTER-KINGPIN GAUGE OR POSITION VEHICLE ON WHEEL ALIGNMENT TESTER

Follow the specific instructions of the equipment manufacturer.

3. INSPECT CAMBER, CASTER AND STEERING AXIS INCLINATION

Camber, caster and steering axis inclination:

Camber		$0^{\circ}05' \pm 45'$ ($0.08^{\circ} \pm 0.75^{\circ}$)
	Right-left error	30' (0.5°) or less
Caster		$2^{\circ}30' \pm 45'$ ($2.5^{\circ} \pm 0.75^{\circ}$)
	Right-left error	30' (0.5°) or less
Steering axis inclination		$12^{\circ}10' \pm 45'$ ($12.17^{\circ} \pm 0.75^{\circ}$)
	Right-left error	30' (0.5°) or less

If the steering axis inclination is not within the specified value, after the camber and caster have been correctly adjusted, recheck the steering knuckle and front wheel for bearing or looseness.

4. ADJUST CAMBER AND CASTER

NOTICE:

After the camber has been adjusted, inspect the toe-in.

- Loosen the front and/or rear adjusting cam nuts.
- Adjust the camber and caster by front and/or rear adjusting cams.

HINT:

Try to adjust the camber and caster to the center of the specified value.

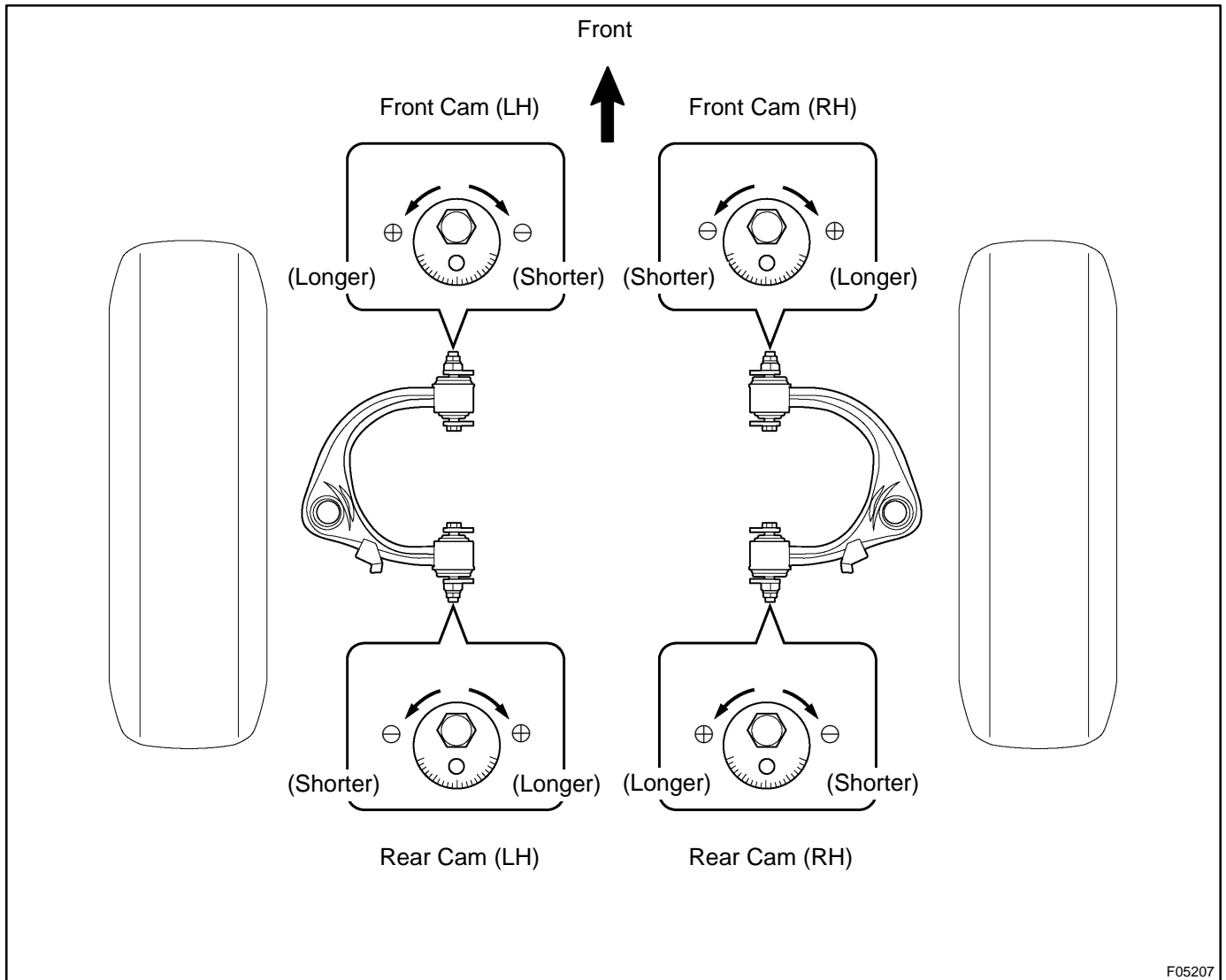

(Example)

- Camber
- - - - - Caster
- = Calculated value
- = 0 point

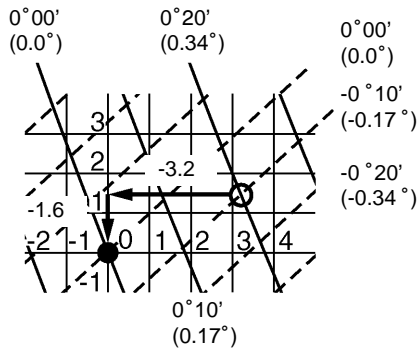

F05095

(c) How to read adjustment chart (using examples).

(1) Measure the present alignment.

Camber: -0°15' (-0.25°)

Caster: 2°40' (2.67°)

(2) Mark the difference between the standard value (A) and the measured value (B) on the adjustment chart.

Standard value:

Camber: 0°05' (0.08°)

Caster: 2°30' (2.5°)

Formula: A - B = C

Camber: 0°05' - (-0°15') = 0°20'

Caster: 2°30' - 2°40' = -0°10'

(3) As shown in the chart, read the distances from the marked point to 0 point, and adjust the front and/or rear adjusting cams accordingly.

Front cam: - (Shorter) 1.6

Rear cam: - (Shorter) 3.2

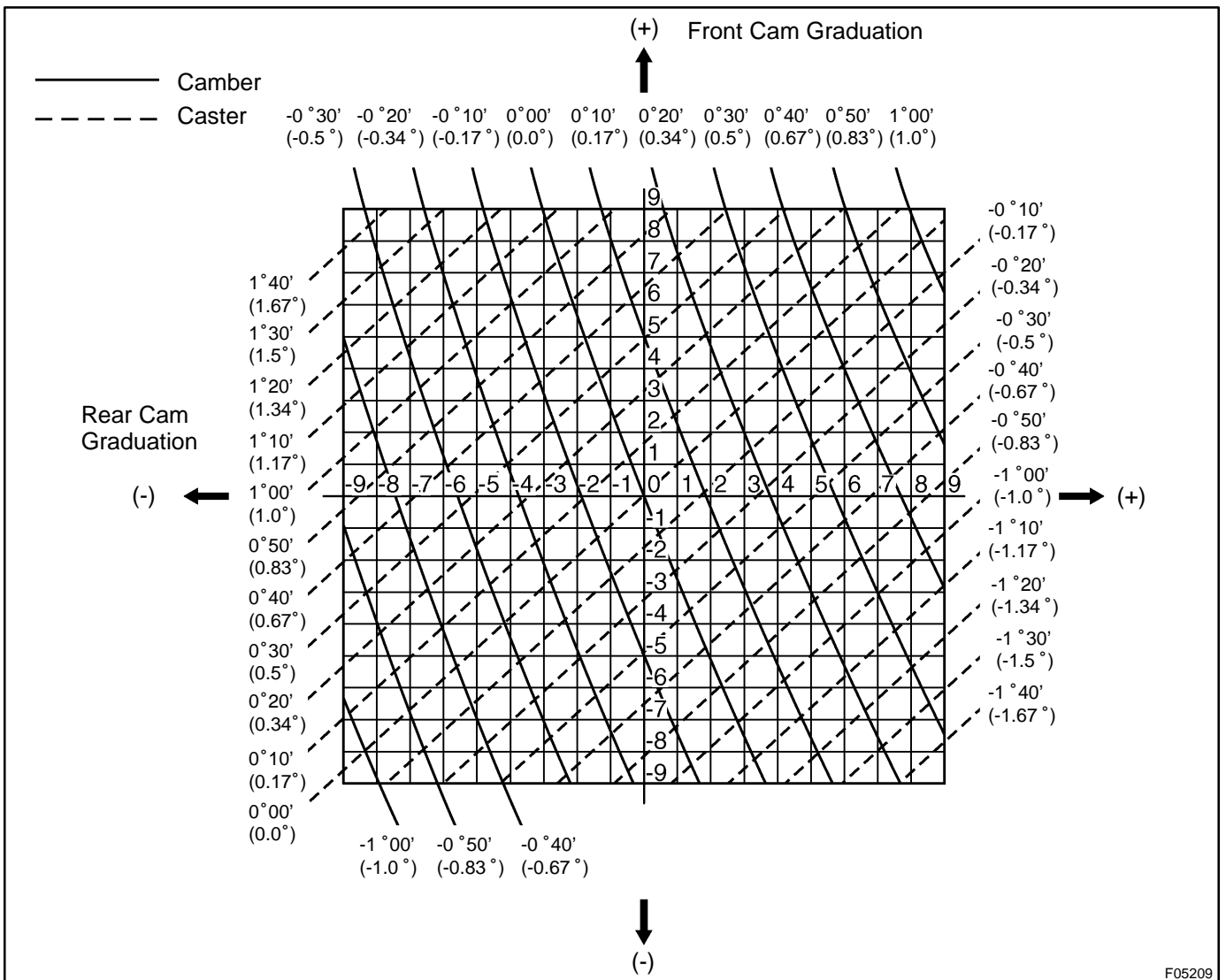

F05209

- (d) Torque the front and/or rear adjusting cam nuts.
Torque: 98 N·m (1,000 kgf-cm, 72 ft-lbf)

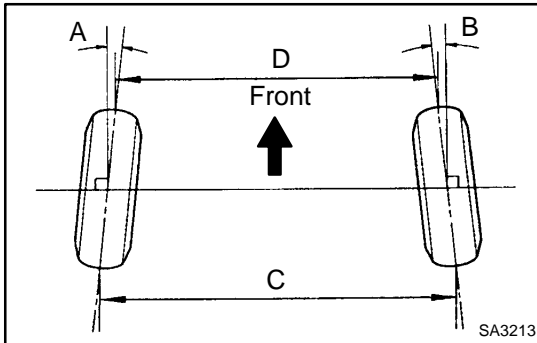

5. INSPECT TOE-IN

Toe-in:

Toe-in (total)	A + B: $0^{\circ}06' \pm 12'$ ($0.1^{\circ} \pm 0.2^{\circ}$) C - D: 1 ± 2 mm (0.04 ± 0.08 in.)
----------------	---

If the toe-in is not within the specified value, adjust it at the rack ends.

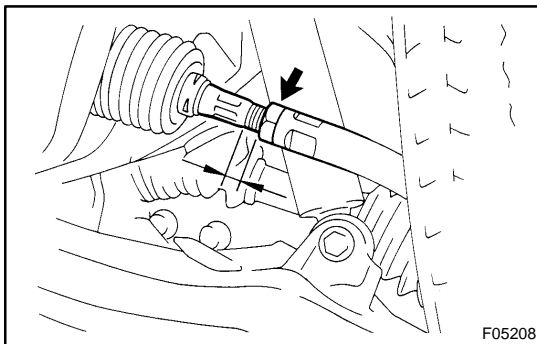

6. ADJUST TOE-IN

- (a) Check or adjust the lengths of the rack ends, then adjust the toe-in.
Rack end length difference: 3.0 mm (0.118 in.) or less
- (b) Remove the boot clamps.
(c) Loosen the tie rod end lock nuts.
(d) Turn the right and left rack ends by an equal amount to adjust the toe-in.

HINT:

Try to adjust the toe-in to the center of the specified value.

- (e) Tighten the tie rod end lock nuts.

Torque: 55 N·m (560 kgf-cm, 41 ft-lbf)

- (f) Place the boots on the seats and install the clamps.

HINT:

Make sure that the boots are not twisted.

- (g) Perform the zero point calibration of yaw rate and deceleration sensor (See page [DI-505](#)).

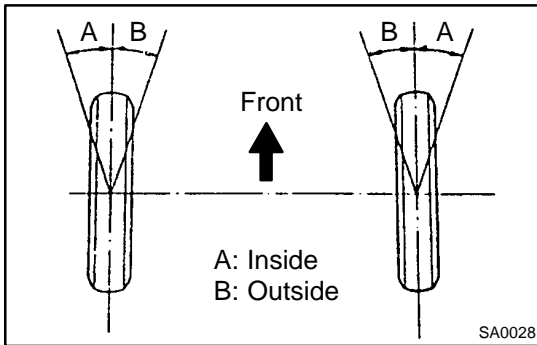

7. INSPECT AND ADJUST WHEEL ANGLE

- (a) Turn the steering wheel fully, and measure the turning angle.

Wheel turning angle:

Inside wheel	36° 42' (33° 42' - 36° 42') 36.7° (33.7° - 36.7°)
Outside wheel: Reference	32° 36' 32.6°

If the right and left inside wheel angles differ from the specified value, check the right and left rack end lengths.

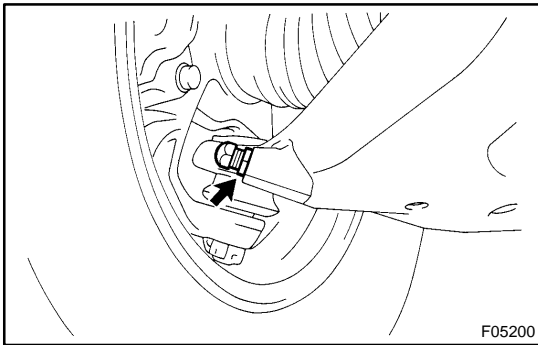

- (b) When toe-in is normal after inspection, adjust wheel angle with the knuckle stopper bolt of the lower suspension arm.

Torque: 44 N·m (450 kgf·cm, 32 ft·lbf)

FRONT WHEEL HUB BOLT REPLACEMENT

SA148-04

1. REMOVE FRONT AXLE HUB (See page SA-12)

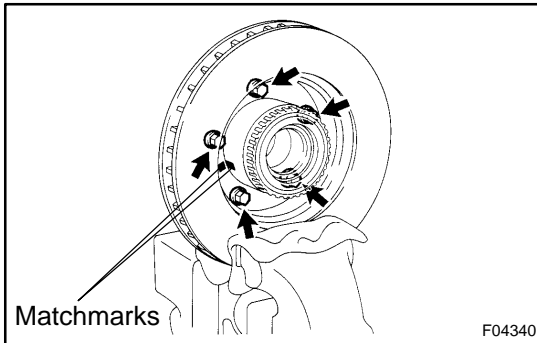

2. REMOVE HUB BOLT

- (a) Mount the axle hub with the disc in a soft jaw vice.

NOTICE:

Close vice until it holds disc, do not tighten further.

- (b) Place matchmarks on the axle hub and disc.
 (c) Remove the 5 bolts and separate the axle hub from the disc.

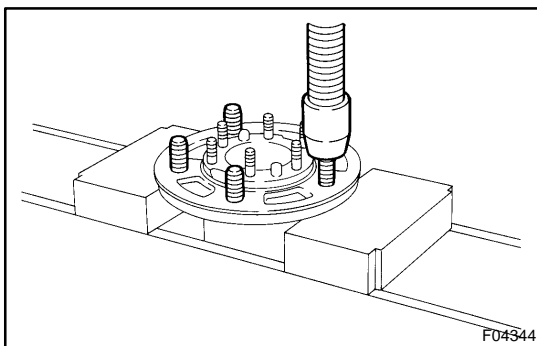

- (d) Using a press, remove the hub bolt.

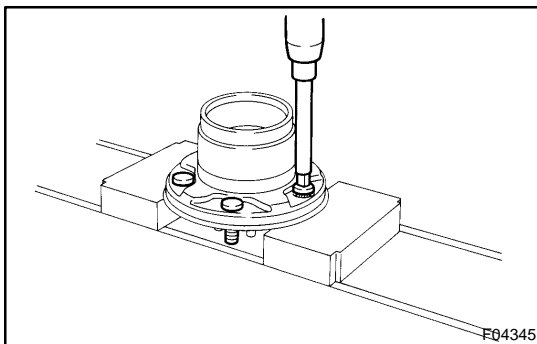

3. INSTALL HUB BOLT

- (a) Using an extension bar and press, install a new hub bolt.

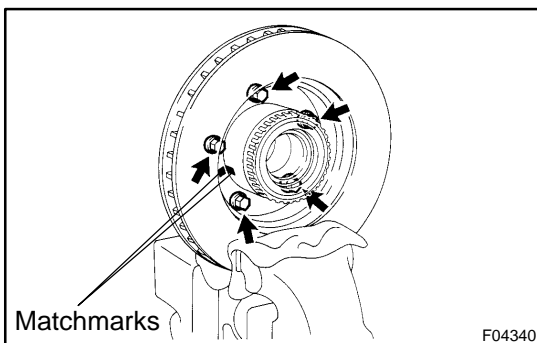

- (b) Align the matchmarks on the axle hub and disc.

- (c) Install the 5 bolts to the axle hub.

Torque: 74 N·m (750 kgf-cm, 55 ft-lbf)

4. INSTALL FRONT AXLE HUB (See page SA-16)

REAR AXLE SHAFT COMPONENTS

SA15C-02

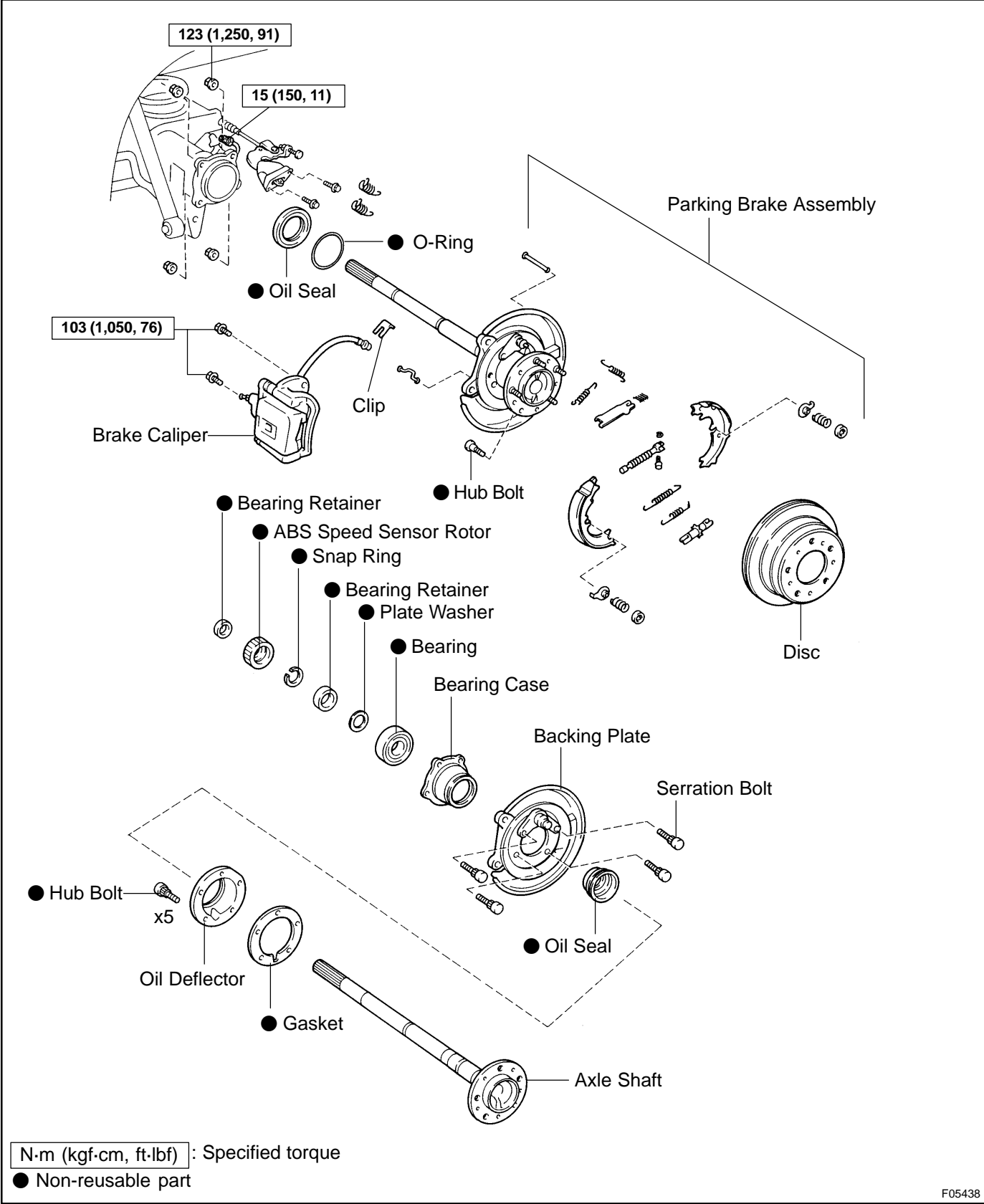

F05438

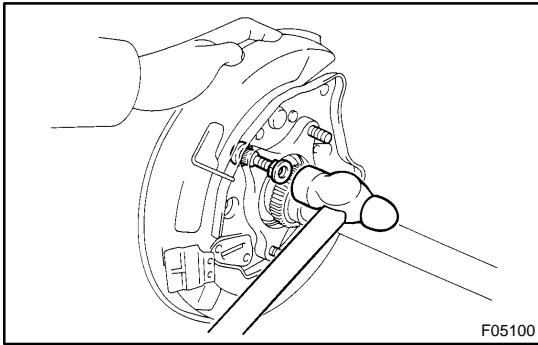

DISASSEMBLY

1. REMOVE BEARING RETAINER (DIFFERENTIAL SIDE) AND ABS SPEED SENSOR ROTOR

- (a) Attach 4 nuts to the serration bolts and using a hammer, remove the serration bolts from the backing plate.

NOTICE:

Do not reuse the nuts previously removed from the vehicle.

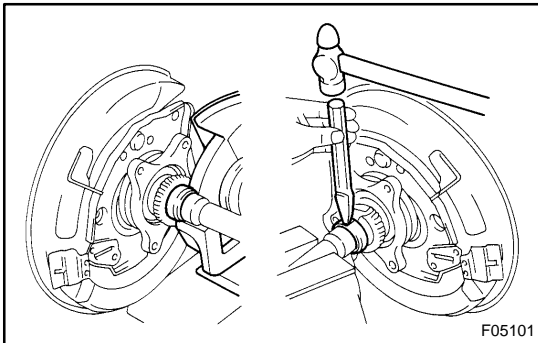

- (b) Grind the retainer and sensor rotor surfaces using a grinder, then pry them out with a chisel and hammer.

2. REMOVE SNAP RING FROM AXLE SHAFT

Using a snap ring expander, remove the snap ring.

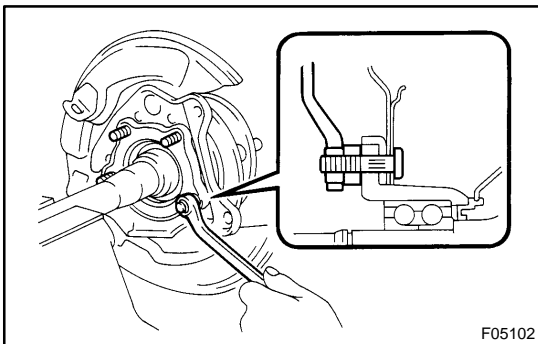

3. REMOVE AXLE SHAFT FROM BACKING PLATE

- (a) Attach 4 washers and nut to the serration bolts, then torque the nuts to install the serration bolts to the backing plate.
- (b) Remove the 4 nuts and washers from the serration bolts.

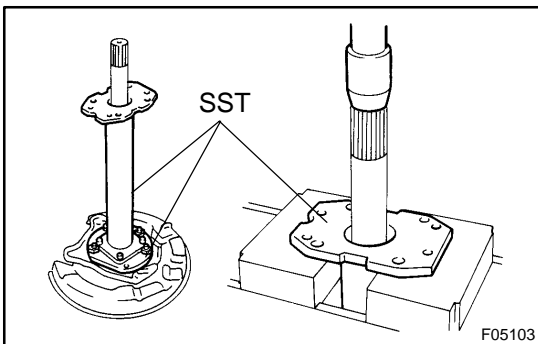

- (c) Position SST on the backing plate with the 4 nuts.

SST 09521-2501 1, 09521-25021

- (d) Using a press, remove the axle shaft, bearing retainer and plate washer from the backing plate.

- (e) Remove the SST.

SST 09521-2501 1, 09521-25021

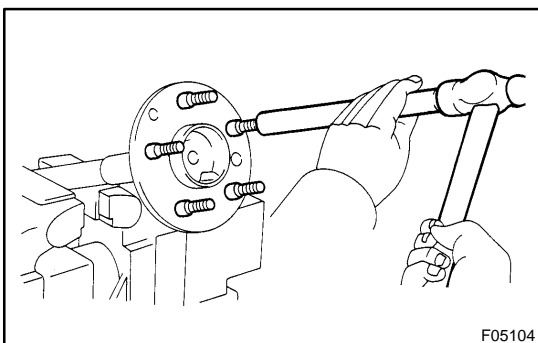

4. REMOVE OIL DEFLECTOR

Using a brass bar and hammer, remove the 5 hub bolts, oil deflector and gasket.

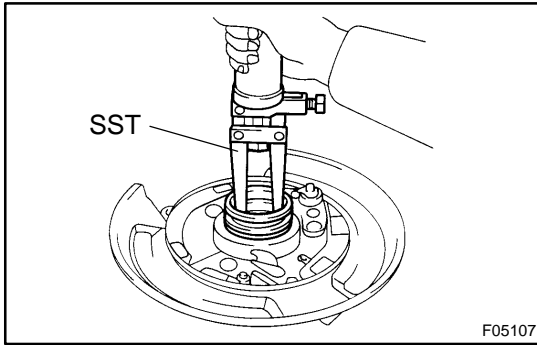

5. REMOVE OUTER OIL SEAL

Using SST, remove the oil seal.
SST 09308-00010

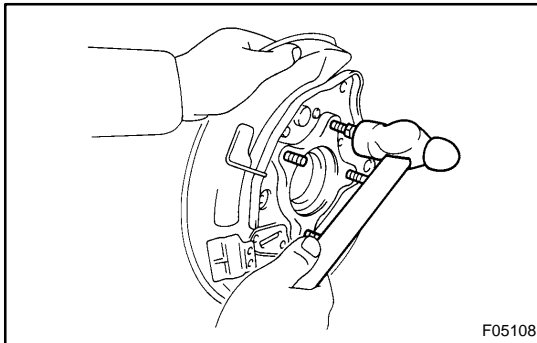

6. REMOVE BEARING CASE

Attach 4 nuts to the serration bolts and remove the serration bolts and bearing case from the backing plate using a hammer.

NOTICE:

Do not reuse the nuts previously removed from the vehicle.

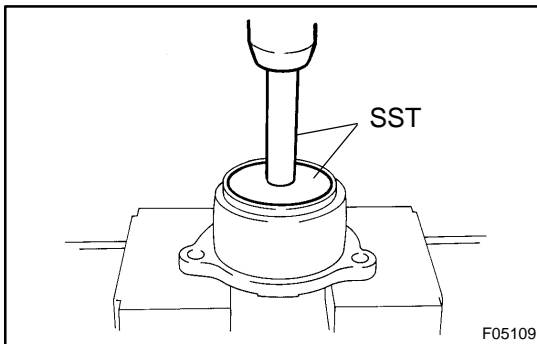

7. REMOVE REAR AXLE BEARING

Using SST and a press, remove the bearing.
SST 09950-60020 (09951-00810),
09950-70010 (09951-07100)

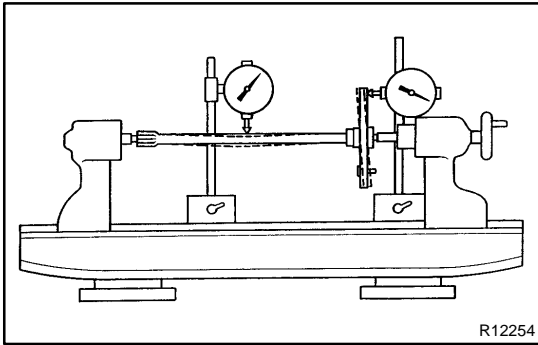

INSPECTION

INSPECT AXLE SHAFT

Using a dial indicator, measure the runout of the shaft and flange.

Maximum shaft runout: 2.0 mm (0.079 in.)

Maximum flange runout: 0.05 mm (0.0020 in.)

If the rear axle shaft or flange are damaged or worn, or if runout is greater than the maximum, replace the rear axle shaft.

INSTALLATION

Installation is in the reverse order of removal (See page [SA-84](#)).

HINT:

After installation, fill the brake reservoir with brake fluid, bleed the brake system (See page [BR-4](#)), check for leaks and check the ABS speed sensor signal (See page [DI-505](#)).

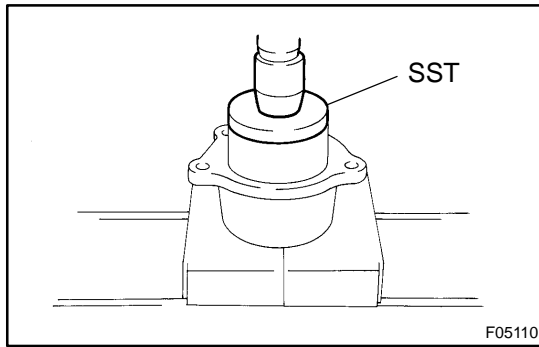

REASSEMBLY

1. INSTALL REAR AXLE BEARING

Using SST and a press, install the bearing.

SST 09950-60020 (09951-00890)

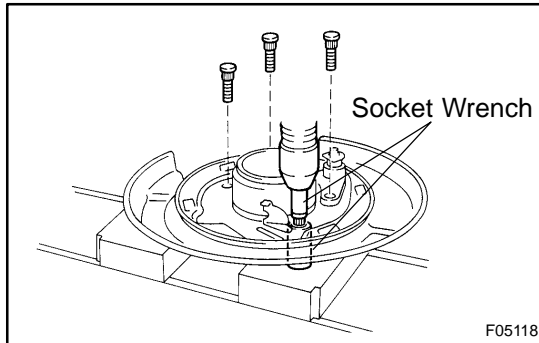

2. INSTALL BEARING CASE

Position the backing plate on the bearing case and using a press and 2 socket wrenches, install the 4 serration bolts.

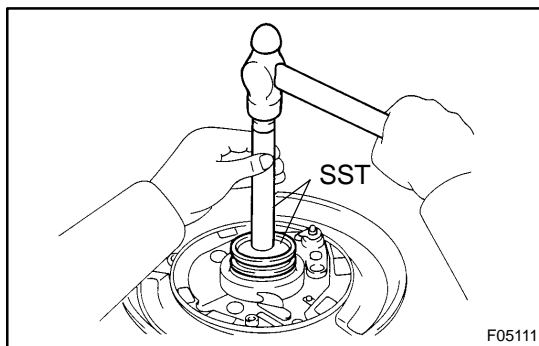

3. INSTALL OUTER OIL SEAL

(a) Using SST and a hammer, install a new oil seal.

SST 09950-60020 (09951-00810),
09950-70010 (09951-07100)

(b) Coat MP grease to the oil seal lip.

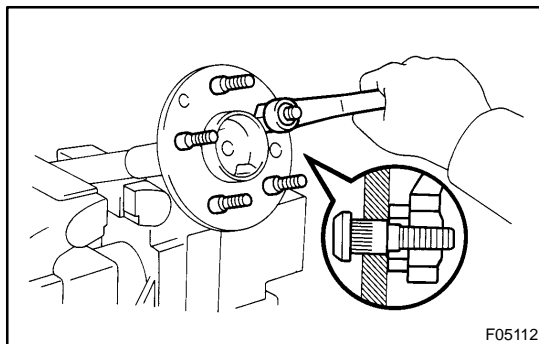

4. INSTALL OIL DEFLECTOR

Position a new gasket and oil deflector on the axle shaft and install a washer and nut to a new hub bolt, as shown in the illustration, and install the 5 hub bolts by torquing the nut.

5. INSTALL AXLE SHAFT TO BACKING PLATE

(a) Install the backing plate, plate washer and bearing retainer on the axle shaft.

(b) Using SST and a press, install the axle shaft into the backing plate.

SST 09631-12090, 09950-60020 (09951-01030)

6. INSTALL SNAP RING TO AXLE SHAFT

Using a snap ring expander, install a new snap ring.

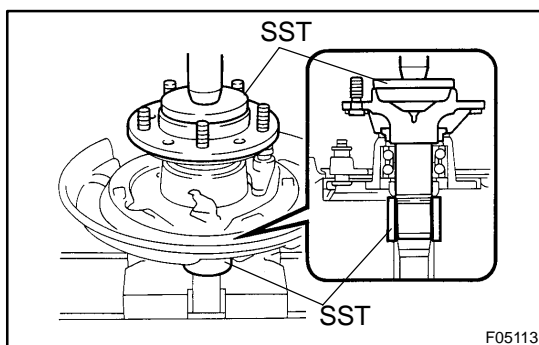

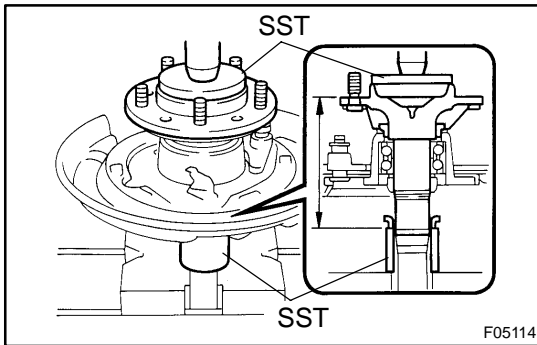

7. INSTALL ABS SPEED SENSOR ROTOR AND BEARING RETAINER

Using SST and a press, install a new ABS speed sensor rotor and bearing retainer.

SST 09631-12090, 09950-60020 (09951-01030)

Standard length: 170.7 ± 1.0 mm (6.720 ± 0.039 in.)

REMOVAL

1. REMOVE REAR WHEEL

Torque: 131 N·m (1,340 kgf·cm, 97 ft·lbf)

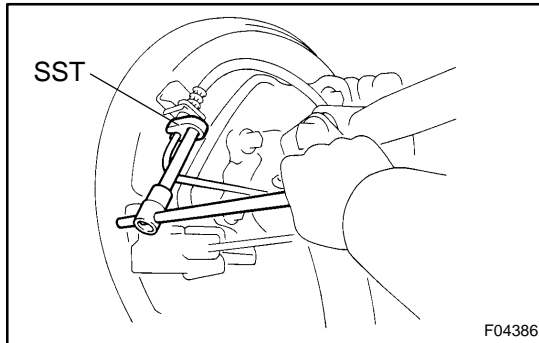

2. DISCONNECT BRAKE LINE

Using SST, disconnect the brake line and remove the clip.

SST 09023-00100

Torque: 15 N·m (150 kgf·cm, 11 ft·lbf)

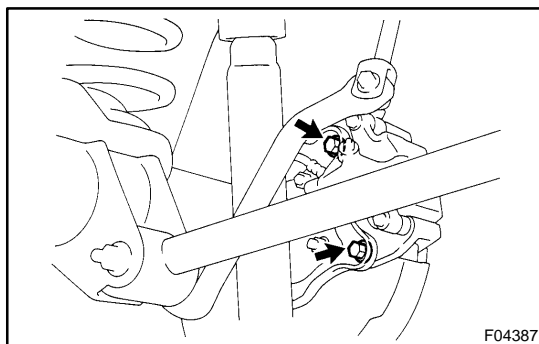

3. REMOVE BRAKE CALIPER AND DISC

Remove the 2 bolts, washers, brake caliper and disc.

Torque: 103 N·m (1,050 kgf·cm, 76 ft·lbf)

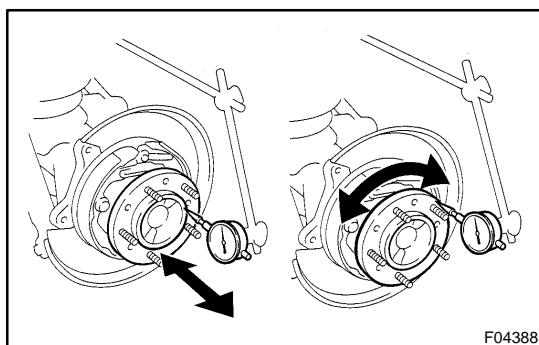

4. CHECK BEARING BACKLASH AND AXLE SHAFT DEVIATION

(a) Using a dial indicator, check the backlash in the bearing shaft direction.

Maximum: 0.6 mm (0.024 in.)

If the backlash exceeds the maximum, replace the bearing.

(b) Using a dial indicator, check the deviation at the surface of the axle shaft outside the hub bolt.

Maximum: 0.05 mm (0.0020 in.)

If the deviation exceeds the maximum, replace the axle shaft.

5. REMOVE PARKING BRAKE ASSEMBLY

(See page [BR-33](#))

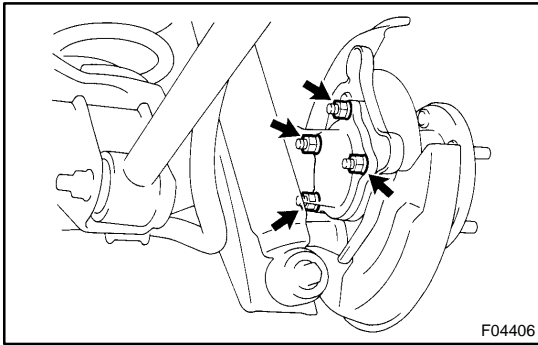
**6. REMOVE AXLE SHAFT ASSEMBLY**

- (a) Remove the 4 nuts.

Torque: 123 N·m (1,250 kgf·cm, 91 ft·lbf)

- (b) Pull out the axle shaft assembly.

NOTICE:

Be careful not to damage the oil seal.

- (c) Remove the O-ring from the bearing case.

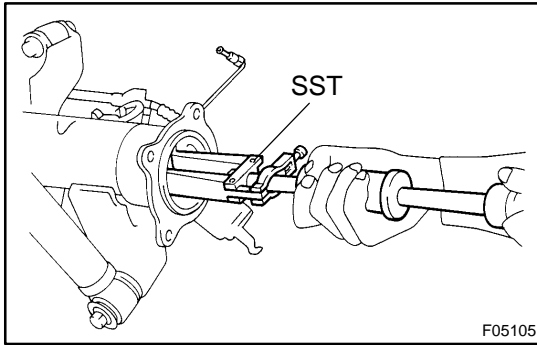

REPLACEMENT

REPLACE OIL SEAL (INNER SIDE)

- (a) Using SST, remove the oil seal.
SST 09308-00010

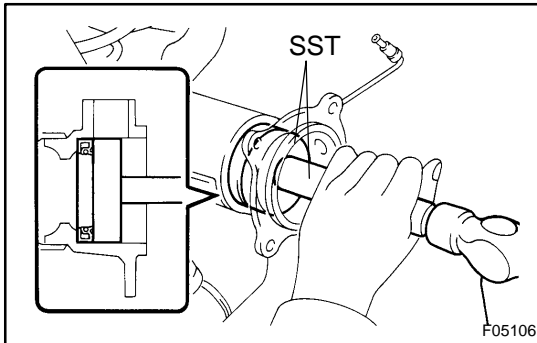

- (b) Using SST and a hammer, install a new oil seal.
SST 09950-60020 (09951-00710),
09950-70010 (09951-07150)
- (c) Coat MP grease to the oil seal lip.

REAR DIFFERENTIAL CARRIER COMPONENTS

SA15M-03

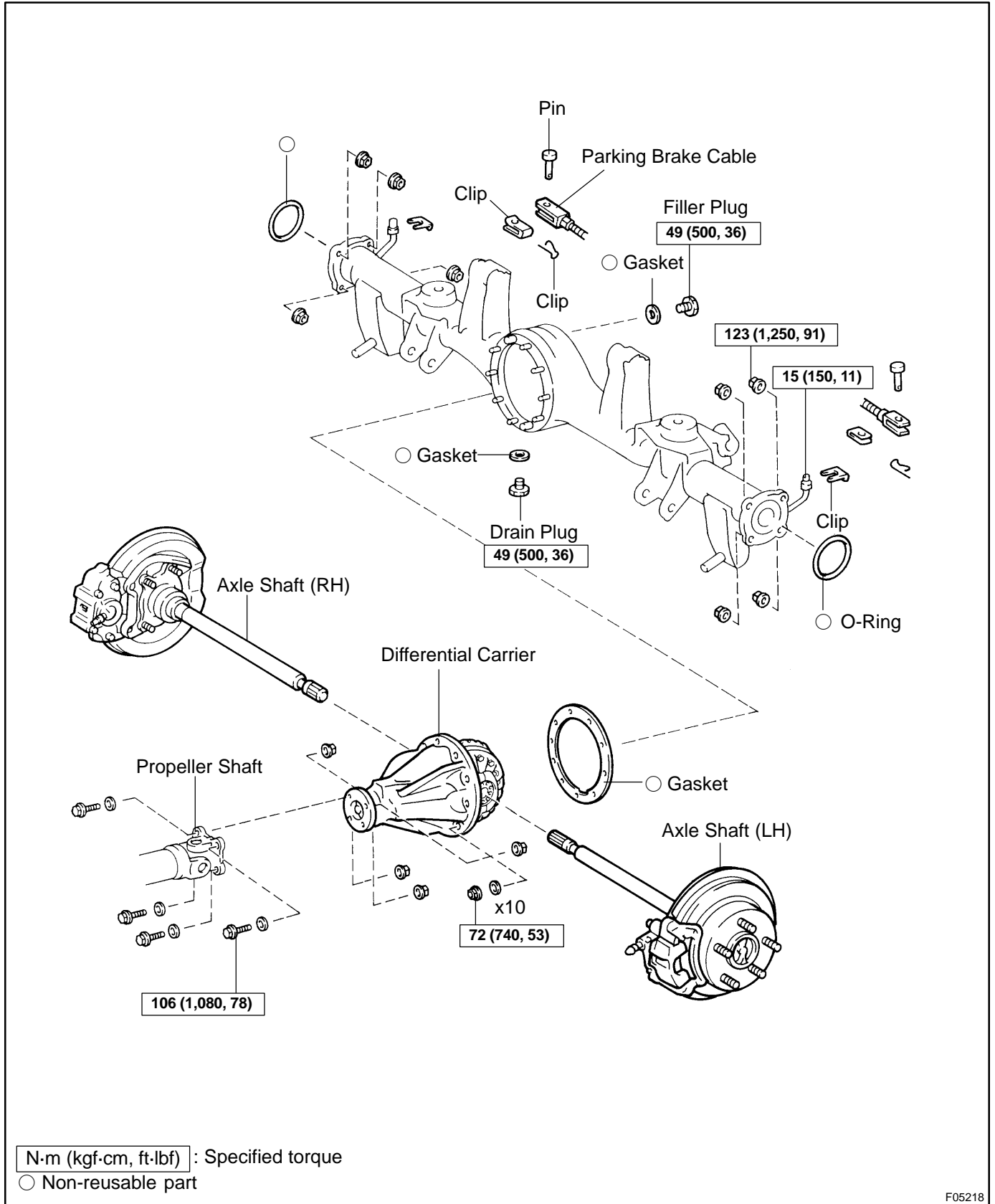

F05218

SUSPENSION AND AXLE - REAR DIFFERENTIAL CARRIER

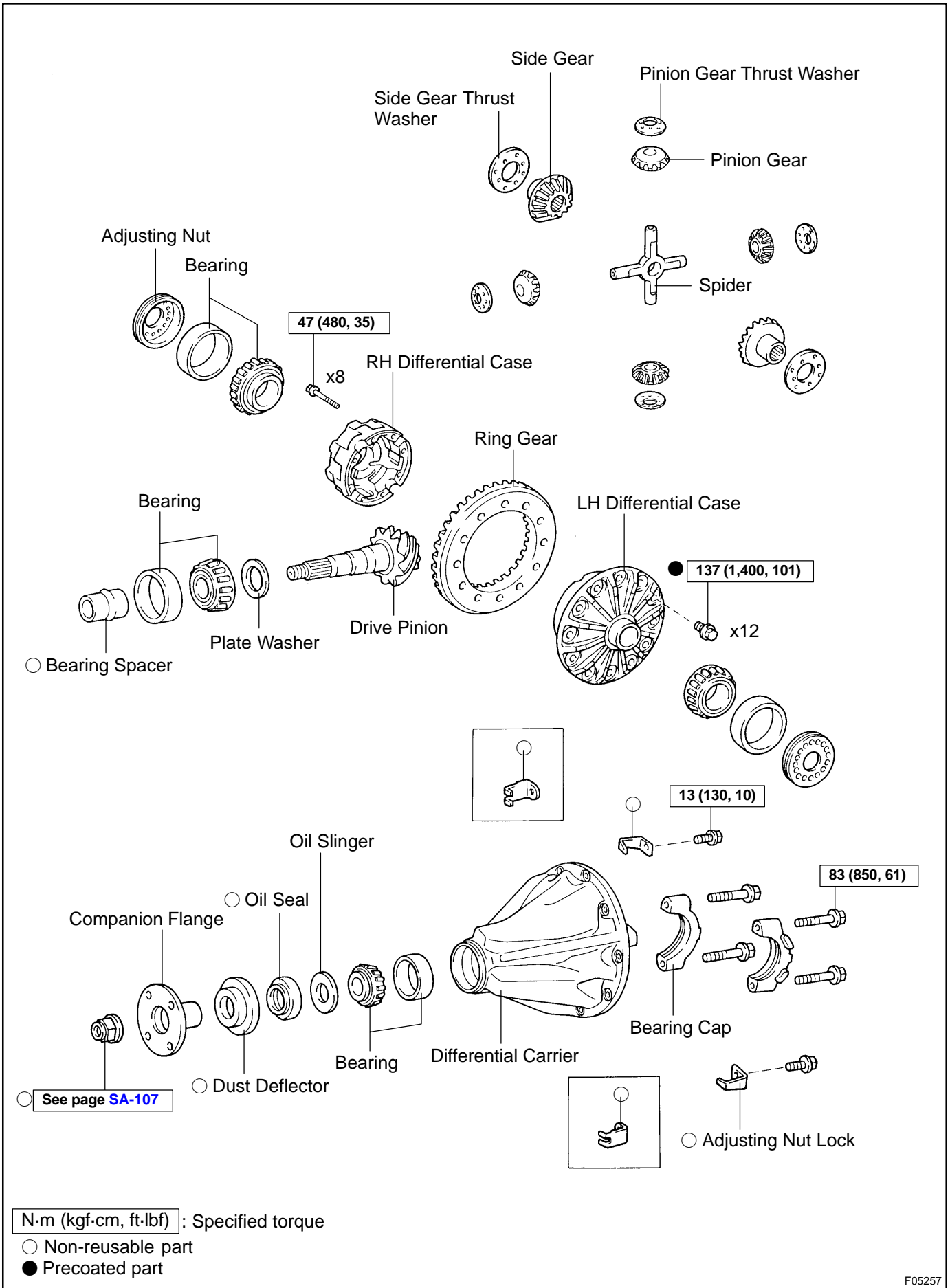

F05257

DISASSEMBLY

1. SET DIFFERENTIAL CARRIER TO OVERHAUL STAND, ETC.

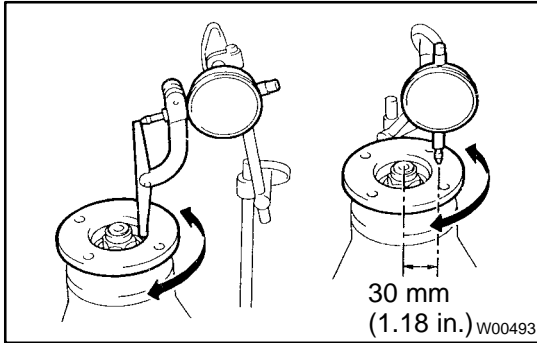

2. CHECK RUNOUT OF COMPANION FLANGE

Using a dial indicator, measure the vertical and lateral runout of the companion flange.

Maximum runout: 0.10 mm (0.0039 in.)

If the runout is greater than the maximum, replace the companion flange.

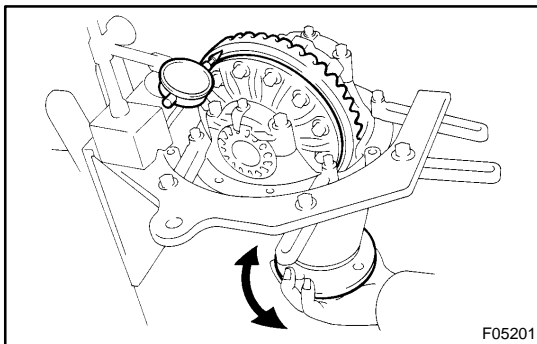

3. CHECK RING GEAR RUNOUT

Using a dial indicator, while holding the drive pinion flange, measure the ring gear runout.

Maximum runout: 0.05 mm (0.0020 in.)

If the runout is greater than the maximum, replace the ring gear.

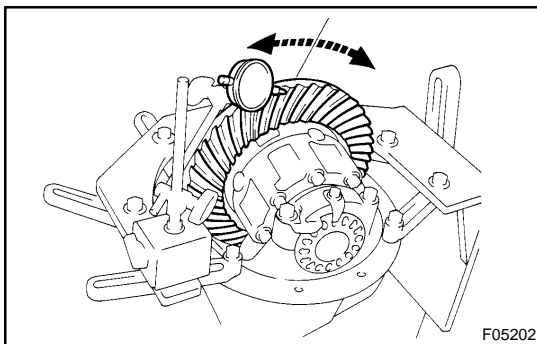

4. CHECK RING GEAR BACKLASH

Using a dial indicator, measure the ring gear backlash.

Backlash: 0.13 - 0.18 mm (0.0051 - 0.0071 in.)

HINT:

Perform the measurements at 3 or more positions around the circumference of the ring gear.

If the backlash is not within the specified value, adjust the side bearing preload or repair as necessary.

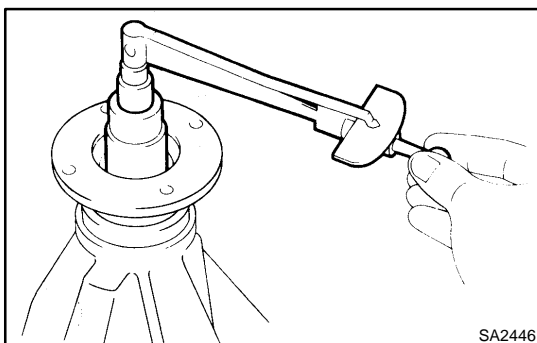

5. MEASURE DRIVE PINION PRELOAD

Using a torque wrench, measure the drive pinion preload using the backlash of the drive pinion and ring gear.

Preload (at starting):

0.64 - 0.92 N·m (6.5 - 9.4 kgf·cm, 5.7 - 8.1 in.-lbf)

6. CHECK TOTAL PRELOAD

Using a torque wrench, measure the total preload with the teeth of the drive pinion and ring gear in contact.

Total preload (at starting):**Drive pinion preload plus**

0.38 - 0.63 N·m (3.9 - 6.5 kgf·cm, 3.3 - 5.6 in.-lbf)

If necessary, disassemble and inspect the differential.

7. CHECK TOOTH CONTACT BETWEEN RING GEAR AND DRIVE PINION (See page SA-107)**8. REMOVE COMPANION FLANGE**

- (a) Using a chisel and hammer, unstake the nut.

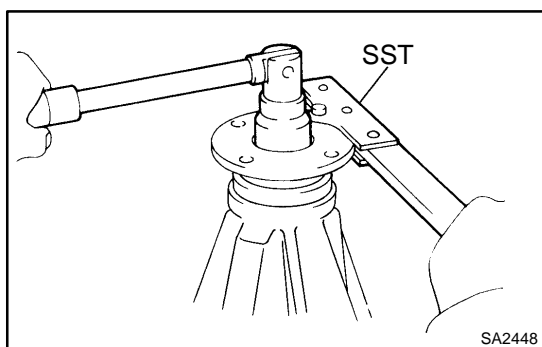

- (b) Using SST to hold the flange, remove the nut.
SST 09330-00021

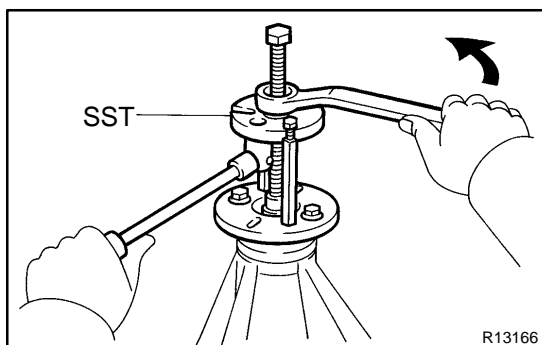

- (c) Using SST, remove the companion flange.
SST 09950-30012 (09951-03010, 09953-03010, 09954-03010, 09955-03030, 09956-03040)

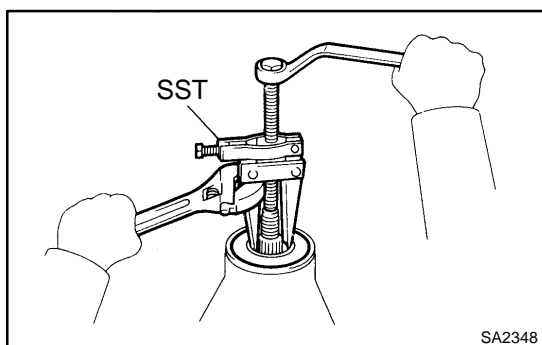
**9. REMOVE OIL SEAL AND OIL SLINGER**

- (a) Using SST, remove the oil seal from the differential carrier.
SST 09308-10010
- (b) Remove the oil slinger.

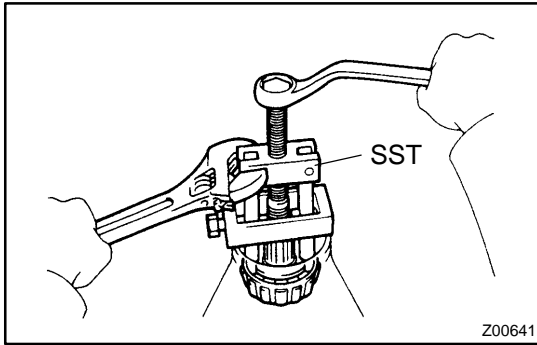
**10. REMOVE FRONT BEARING**

Using SST, remove the front bearing from the drive pinion.

SST 09556-22010

If the front bearing is damaged or worn, replace the bearing.

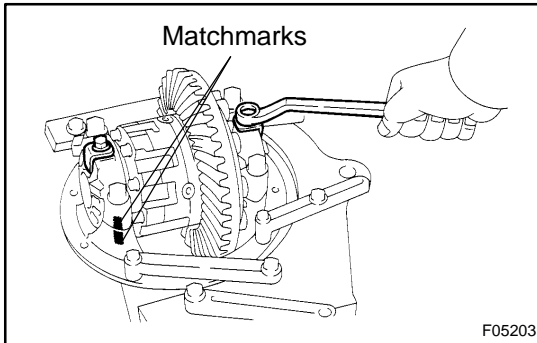
**11. REMOVE DIFFERENTIAL CASE ASSEMBLY**

(a) Place matchmarks on the bearing cap and differential carrier.

(b) Remove the 2 bolts and adjusting nut locks.

(c) Remove the 4 bolts, 2 bearing caps and adjusting nuts.

HINT:

Tag the disassembled parts to show the location for reassembling.

(d) Remove the differential case with the bearing outer races from the carrier.

HINT:

Tag the disassembled parts to show the location for reassembling.

12. REMOVE DRIVE PINION AND BEARING SPACER FROM DIFFERENTIAL CARRIER

(a) Remove the drive pinion with the rear bearing.

(b) Remove the bearing spacer.

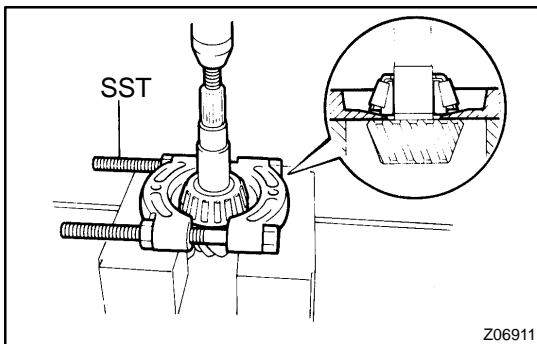
**13. REMOVE DRIVE PINION REAR BEARING**

(a) Using SST and a press, remove the rear bearing from the drive pinion.

SST 09950-00020

HINT:

If the drive pinion or ring gear is damaged, replace them as a set.

(b) Remove the plate washer from the drive pinion.

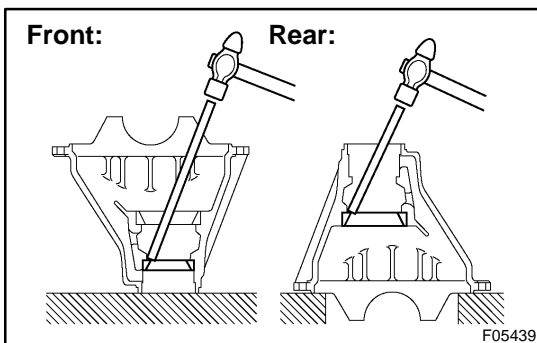
**14. REMOVE FRONT AND REAR BEARING OUTER RACES**

Using a brass bar and hammer, remove the outer races.

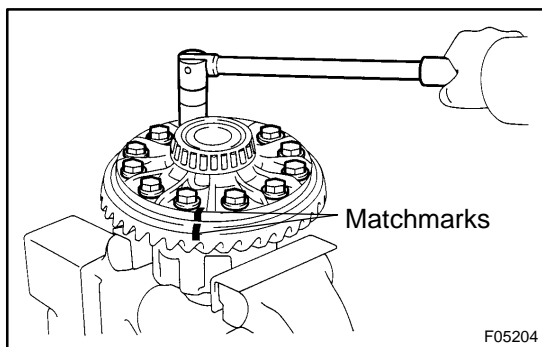
**15. REMOVE RING GEAR**

- Place matchmarks on the ring gear and differential case.
- Remove the 12 ring gear set bolts.
- Using a plastic hammer, tap on the ring gear to remove it from the differential case.

16. CHECK DIFFERENTIAL CASE RUNOUT

- Place the bearing outer races on their respective bearings. Check that the right and left outer races are not interchanged.
- Install the differential case in the differential carrier.
- Tighten the adjusting nut just to where there is no play in the bearing.
- Align the matchmarks on the bearing cap and differential carrier.
- Install and uniformly tighten the 4 bearing cap bolts a little at a time.

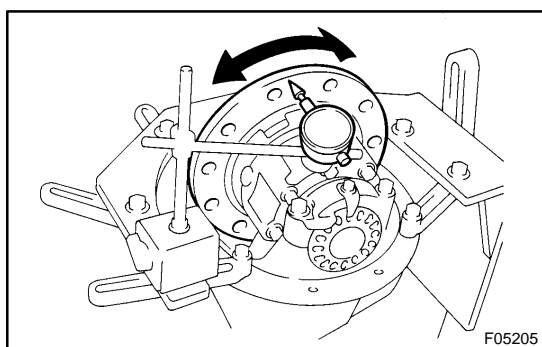

- Using a dial indicator, measure the differential case runout.

Maximum case runout: 0.04 mm (0.0016 in.)

- Remove the differential case.

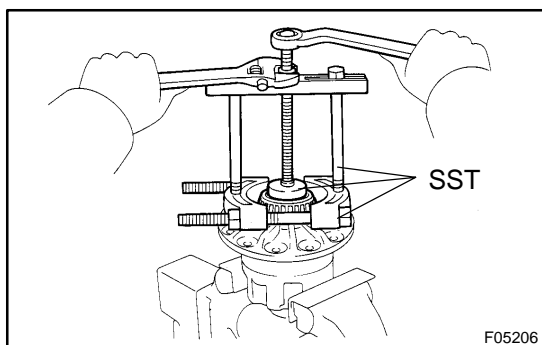
**17. REMOVE SIDE BEARINGS FROM DIFFERENTIAL CASE**

Using SST, remove the 2 side bearings from the differential case.

SST 09950-00020, 09950-00030,
09950-4001 1 (09957-04010),
09950-60010 (09951-00480)

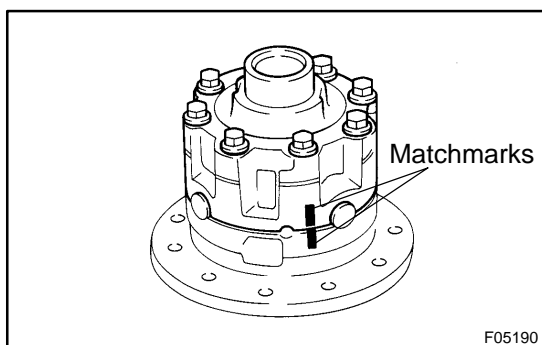
**18. DISASSEMBLE DIFFERENTIAL CASE**

- Place matchmarks on the RH and LH differential cases.
- Remove the 8 bolts uniformly, a little at a time.
- Using a plastic hammer, separate the RH and LH differential cases.
- Remove the 2 side gear thrust washers, 2 side gears, spider, 4 pinion gears and pinion gear thrust washers.

INSTALLATION

Installation is in the reverse order of removal (See page [SA-100](#)).

HINT:

After installation, fill the differential with hypoid gear oil (See page [SA-95](#)), fill the brake reservoir with brake fluid, bleed the brake system (See page [BR-4](#)), check for leaks and check the ABS speed sensor signal (See page [DI-505](#)).

REASSEMBLY

HINT:

- Using a shop rag, clean off any foreign object from the parts.
- Apply all of the sliding and rotating surfaces with hypoid gear oil.

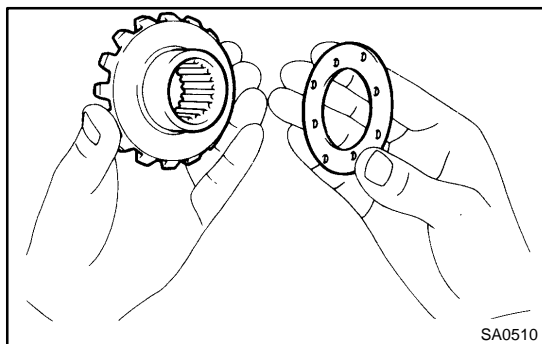

1. MEASURE SIDE GEAR BACKLASH

- (a) Install the 2 thrust washers to the side gears.
- (b) Install the side gear to the differential case.
- (c) Install the 4 pinion gears and thrust washers to the spider.
- (d) Install the spider assembly to the differential case.

HINT:

Install the spider to the differential case tightly.

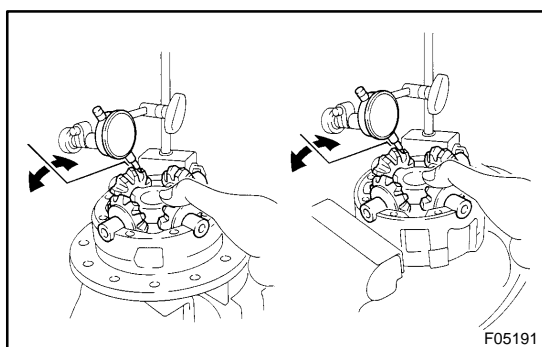

- (e) Using a dial indicator, measure the side gear backlash holding the side gear and spider.

Backlash: 0.02 - 0.15 mm (0.0008 - 0.0059 in.)

HINT:

- Measure at all 4 locations.
- Measure the backlash at the RH and LH differential cases.

If the backlash is not within the specified value, install a thrust washer of a different thickness.

Thrust washer thickness:

Thickness mm (in.)	Thickness mm (in.)
1.55 (0.061)	1.85 (0.073)
1.60 (0.063)	1.90 (0.075)
1.65 (0.065)	1.95 (0.077)
1.70 (0.067)	2.00 (0.079)
1.75 (0.069)	2.05 (0.081)
1.80 (0.071)	2.10 (0.083)

2. ASSEMBLE DIFFERENTIAL CASE

- (a) Reinstall the spider to the differential case.

HINT:

Install the spider to the differential case tightly.

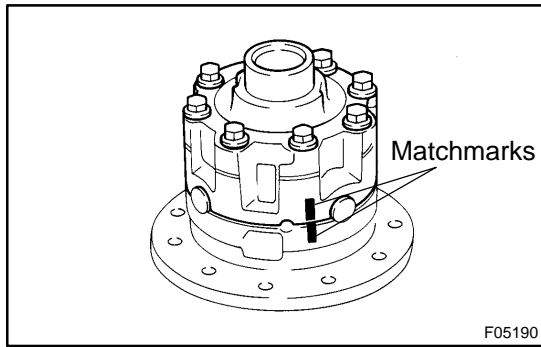

- (b) Align the matchmarks and assemble the RH and LH differential cases.
- (c) Tighten the 8 bolts uniformly, a little at a time.
Torque: 47 N·m (480 kgf·cm, 35 ft·lbf)

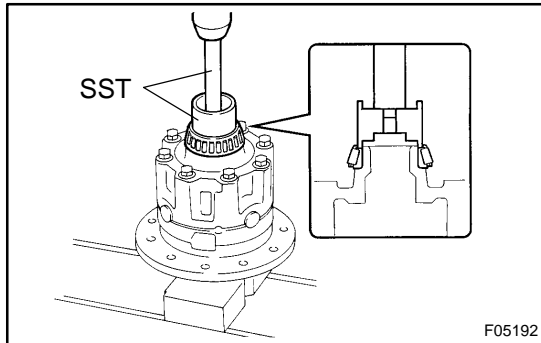

3. INSTALL SIDE BEARINGS

- (a) Using SST and a press, install the RH side bearing on the differential case.
SST 09710-30050, 09950-70010 (09951-07100)

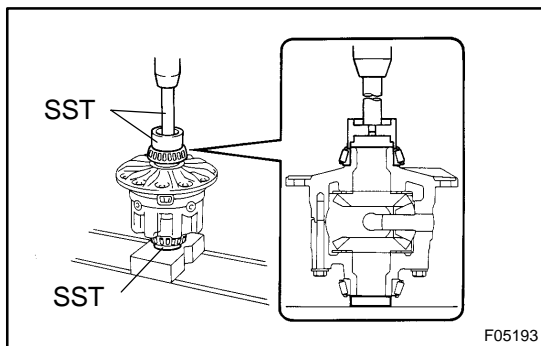

- (b) Using SST and a press, install the LH side bearing on the differential case.
SST 09710-30050, 09950-60010 (09951-00480),
09950-70010 (09951-07100)

4. INSTALL RING GEAR ON DIFFERENTIAL CASE

- (a) Clean the threads of the bolts and differential case with the white gasoline.
- (b) Clean the contact surfaces of the differential case and ring gear.
- (c) Heat the ring gear to about 100 °C (212 °F) in boiling water.
- (d) Carefully take the ring gear out of the boiling water.
- (e) After the moisture on the ring gear has completely evaporated, quickly install the ring gear to the differential case.

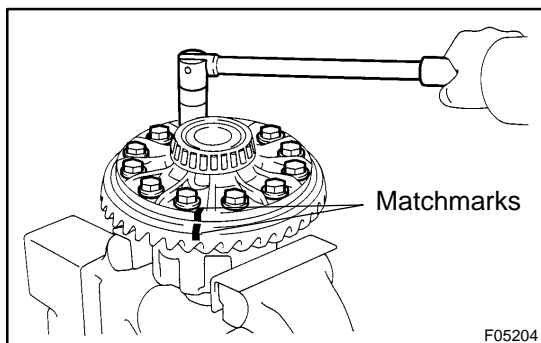
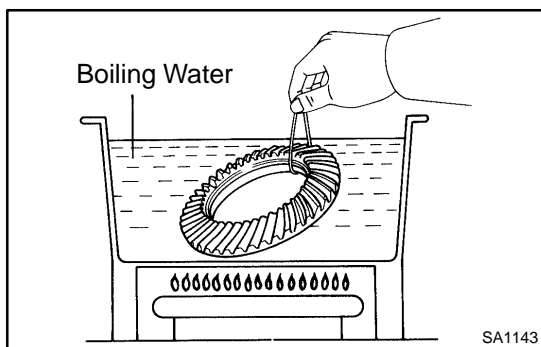

- (f) Align the matchmarks on the ring gear and differential case.
- (g) Temporarily install the 12 set bolts.
- (h) After the ring gear cools down enough, torque the 12 set bolts to which thread lock has been applied.

Thread lock:

Part No. 08833-00100, THREE BOND 1360 K or equivalent

Torque: 137 N·m (1,400 kgf·cm, 101 ft·lbf)

5. CHECK RING GEAR RUNOUT

- (a) Place the bearing outer races on their respective bearings. Check that the right and left outer races are not interchanged.
- (b) Install the differential case onto the carrier and tighten the adjusting nut just to where there is no play in the bearings.

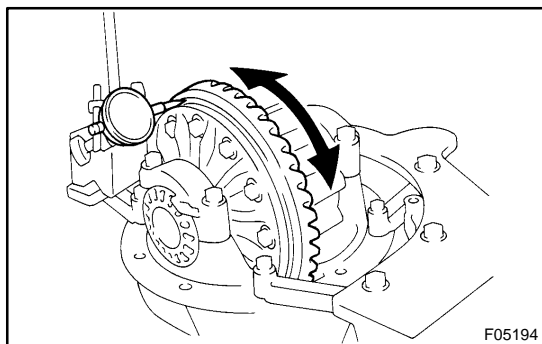

- (c) Using a dial indicator, check the ring gear runout.
Maximum runout: 0.05 mm (0.0020 in.)
- (d) Remove the differential case.

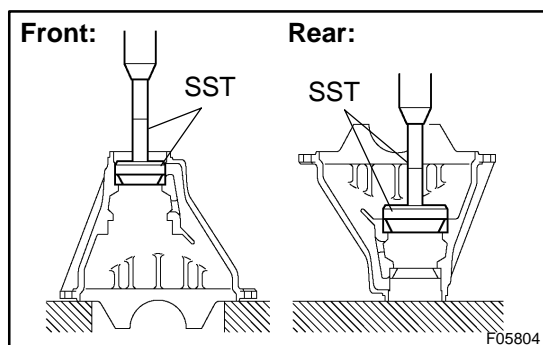
**6. INSTALL FRONT AND REAR BEARING OUTER RACES**

- (a) Using SST and a press, install the front bearing outer race.
SST 09950-60020 (09951-00710),
09950-70010 (09951-07150)
- (b) Using SST and a press, install the rear bearing outer race.
SST 09950-60020 (09951-00890),
09950-70010 (09951-07150)

7. INSTALL DRIVE PINION REAR BEARING

- (a) Install the plate washer on the drive pinion.

HINT:

First fit a washer with the same thickness as the washer which was removed, then after checking the tooth contact pattern, replace the washer with one of a different thickness if necessary.

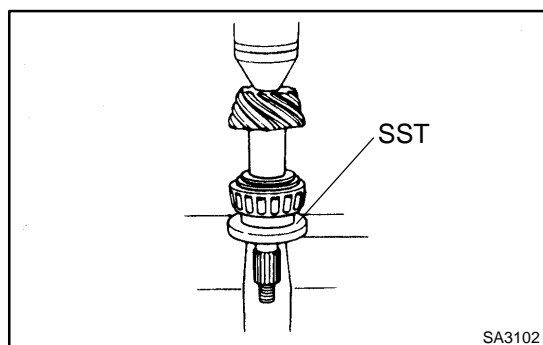

- (b) Using SST and a press, install the rear bearing onto the drive pinion.
SST 09506-35010

8. TEMPORARILY ADJUST DRIVE PINION PRELOAD

- (a) Install the drive pinion and front bearing.

HINT:

Assemble the spacer and oil seal after adjusting the gear contact pattern.

- (b) Install the oil slinger.

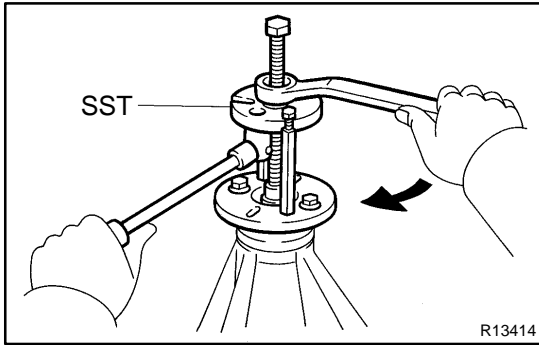

- (c) Install the companion flange with SST.
SST 09950-30012 (09951-03010, 09953-03010, 09954-03010, 09955-03030, 09956-03040)

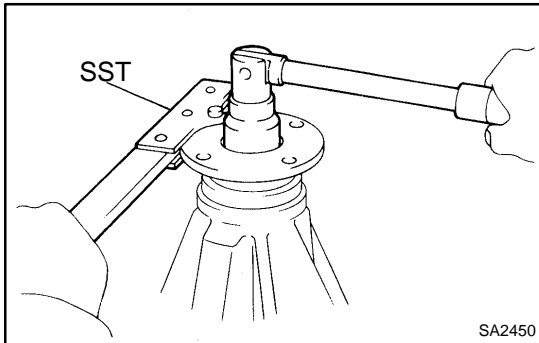

- (d) Using SST to hold the flange and adjust the drive pinion preload by tightening the companion flange nut.
SST 09330-00021

NOTICE:

- Coat the nut and screw of the drive pinion with gear oil.
- As there is no spacer, tighten the nut a little at a time, being careful not to overtighten.

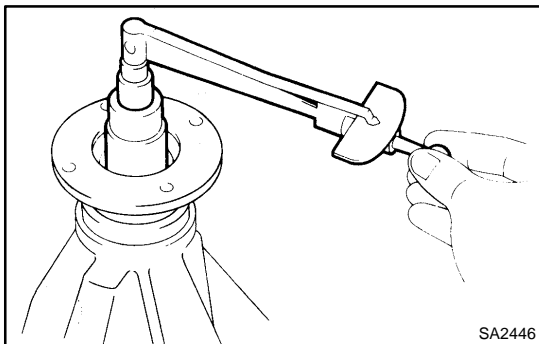

- (e) Using a torque wrench, measure the preload.

Preload (at starting):**New bearing**

1.3 - 1.8 N·m (13 - 19 kgf·cm, 11.5 - 15.9 in.-lbf)

Reused bearing

0.64 - 0.92 N·m (6.5 - 9.4 kgf·cm, 5.7 - 8.1 in.-lbf)

HINT:

Measure the total preload after turning the bearing clockwise and counterclockwise several times to make the bearing smooth.

9. INSTALL DIFFERENTIAL CASE IN CARRIER

- (a) Place the 2 bearing outer races on their respective bearings. Make sure that the right and left outer races are not interchanged.
- (b) Install the differential case in the carrier.

HINT:

Make sure that there is backlash between the ring gear and drive pinion.

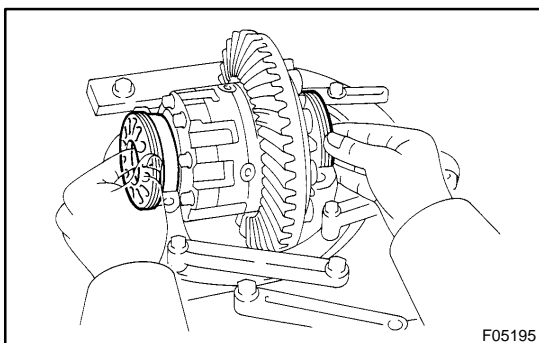
**10. INSTALL ADJUSTING NUTS**

Install the 2 adjusting nuts on the carrier, making sure the nuts are engaged properly.

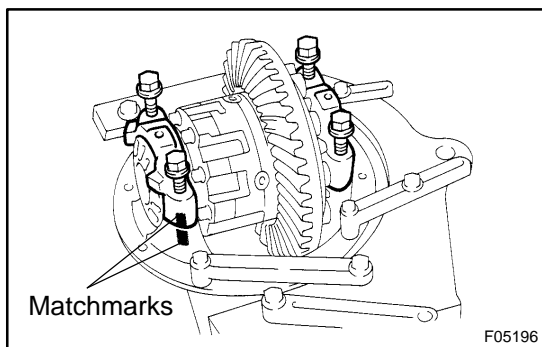

11. INSTALL BEARING CAPS

Align the matchmarks on the bearing cap and carrier. Screw in the 2 bearing cap bolts 2 or 3 turns and press down the bearing cap by hand.

HINT:

If the bearing cap does not fit tightly on the carrier, the adjusting nuts are not engaged properly. Reinstall the adjusting nuts if necessary.

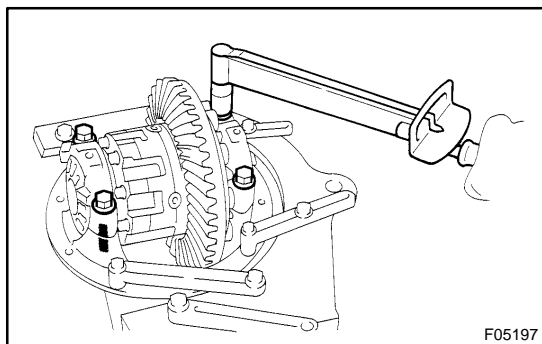

12. ADJUST SIDE BEARING PRELOAD

(a) Torque the 4 bolts.

Torque: 83 N·m (850 kgf·cm, 61 ft·lbf)

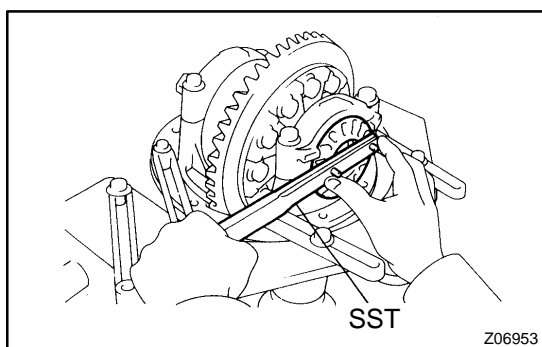

(b) Then loosen them to the point where the adjusting nuts can be turned by SST.

SST 09504-0001 1

(c) Tighten the 4 bolts.

Torque: 9.8 N·m (100 kgf·cm, 7 ft·lbf)

(d) Using SST, torque the adjusting nut on the ring gear side until the ring gear has a backlash of about 0.2 mm (0.008 in.).

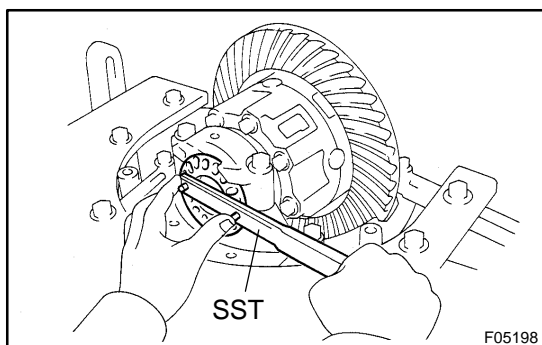

(e) While turning the ring gear, use the SST to fully tighten the adjusting nut on the drive pinion side. After the bearings are settled, loosen the adjusting nut on the drive pinion side.

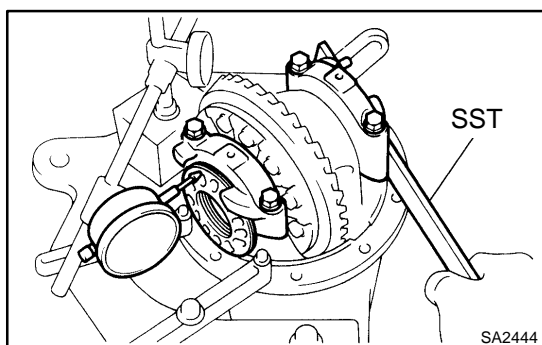

(f) Place a dial indicator on the top of the adjusting nut on the ring gear side.

(g) Adjust the side bearing to zero preload by tightening the other adjusting nut until the pointer on the indicator begins to move.

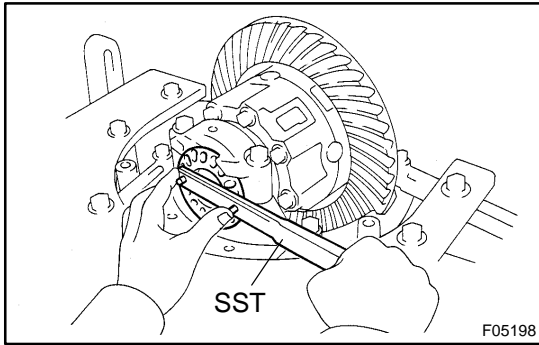

- (h) Using the SST, torque the adjusting nut 1 - 1.5 notches from the zero preload position.

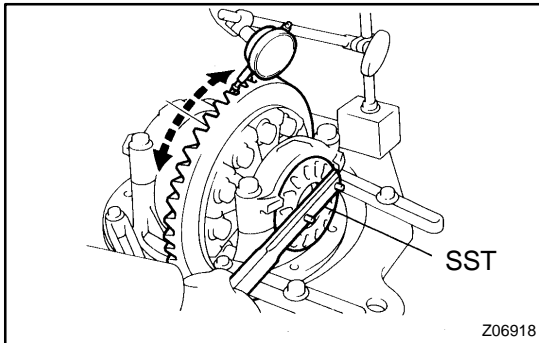

- (i) Using a dial indicator, adjust the ring gear backlash until it is within the specified value.

Backlash: 0.13 - 0.18 mm (0.0051 - 0.0071 in.)

HINT:

The backlash is adjusted by turning the right and left adjusting nuts by equal amount. For example, loosen the nut on the left side 1 notch and torque the nut on the right side 1 notch.

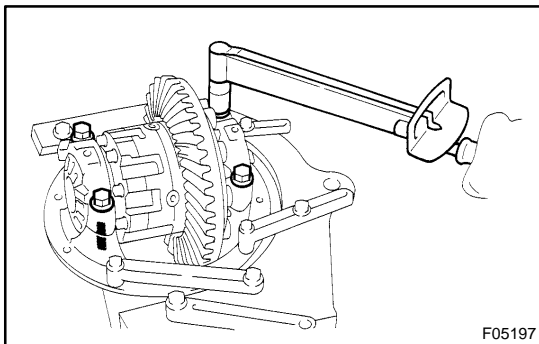

- (j) Torque the 4 bearing cap bolts.

Torque: 83 N·m (850 kgf·cm, 61 ft·lbf)

- (k) After rotating the ring gear 5 turns or more, recheck the ring gear backlash.

Backlash: 0.13 - 0.18 mm (0.0051 - 0.0071 in.)

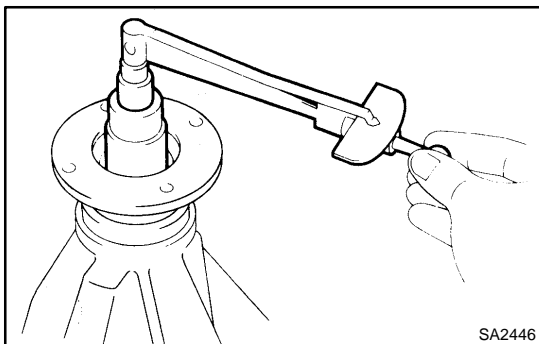

13. MEASURE TOTAL PRELOAD

Using a torque wrench, measure the preload with the teeth of the drive pinion and ring gear in contact.

Preload (at starting):

Drive pinion preload plus

0.38 - 0.63 N·m (3.9 - 6.5 kgf·cm, 3.3 - 5.6 in.-lbf)

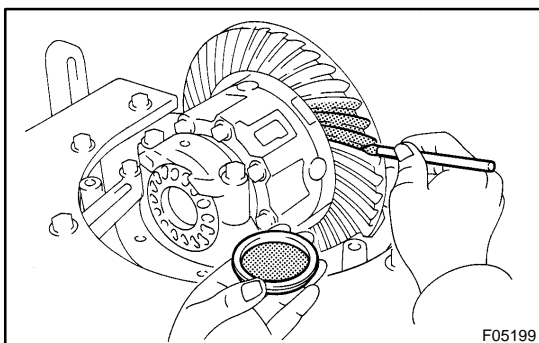

14. INSPECT TOOTH CONTACT BETWEEN RING GEAR AND DRIVE PINION

- (a) Coat 3 or 4 teeth at 3 different positions on the ring gear with red lead primer.

- (b) Turn the companion flange, in both directions to inspect the ring gear for proper tooth contact.

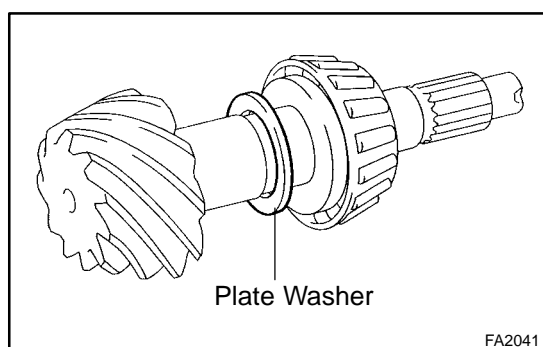
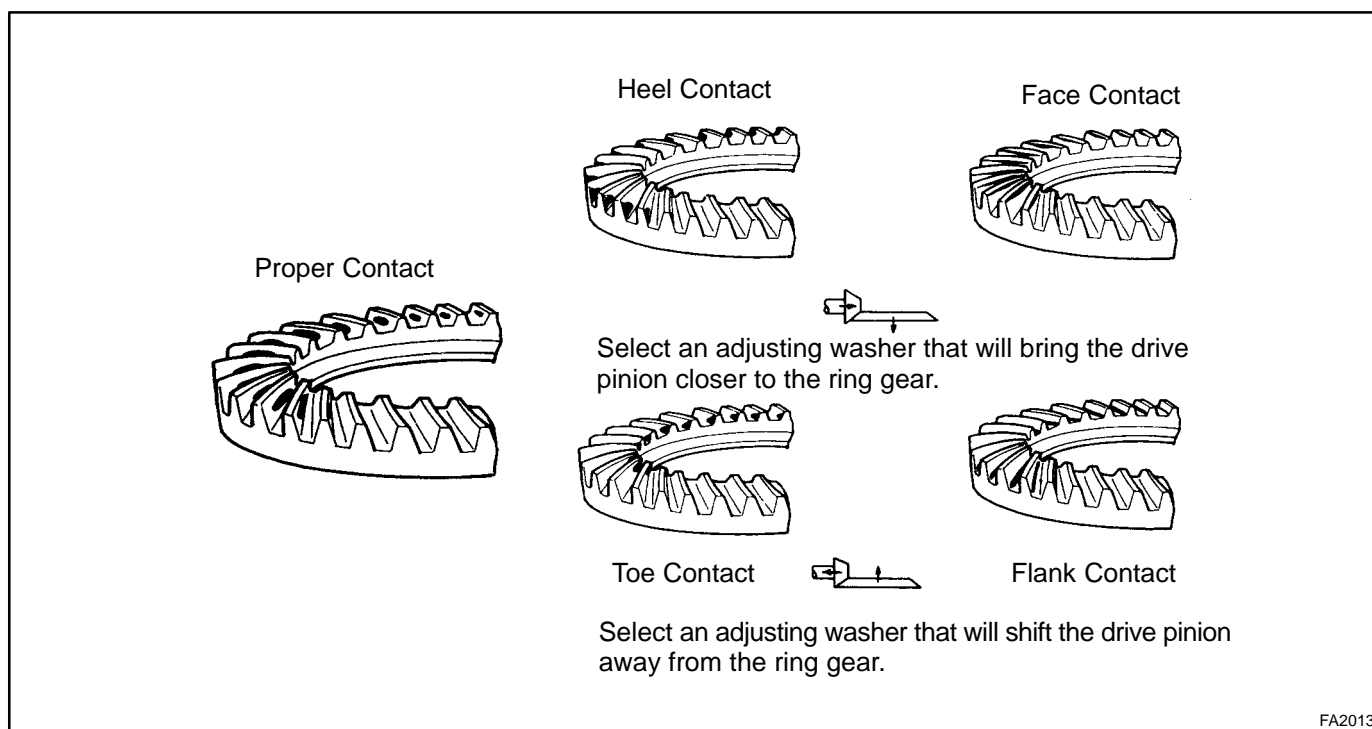

If the teeth are not contacting properly, use the following table to select a proper washer for correction.

Plate washer thickness:

Thickness mm (in.)	Thickness mm (in.)
1.050 (0.04134)	1.325 (0.05217)
1.075 (0.04232)	1.350 (0.05315)
1.100 (0.04331)	1.375 (0.05413)
1.125 (0.04429)	1.400 (0.05512)
1.150 (0.04528)	1.425 (0.05610)
1.175 (0.04626)	1.450 (0.05709)
1.200 (0.04724)	1.475 (0.05807)
1.225 (0.04823)	1.500 (0.05906)
1.250 (0.04921)	1.525 (0.06004)
1.275 (0.05020)	1.550 (0.06102)
1.300 (0.05118)	-

15. REMOVE COMPANION FLANGE (See page SA-102)
16. REMOVE OIL SLINGER AND FRONT BEARING (See page SA-102)

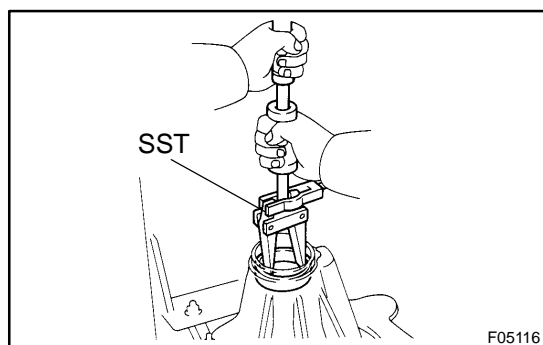

17. REMOVE BEARING OUTER RACE
Using SST, remove the bearing outer race.
SST 09308-00010
18. INSTALL NEW BEARING SPACER

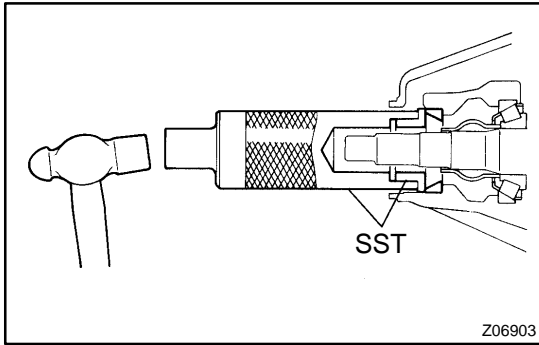
**19. INSTALL BEARING OUTER RACE**

Using SST and a hammer, install the bearing outer race.

SST 09316-6001 1 (09316-00011, 09316-00021)

20. INSTALL FRONT BEARING AND OIL SLINGER**21. INSTALL OIL SEAL**

(a) Coat the hypoid gear oil to a new oil seal periphery.

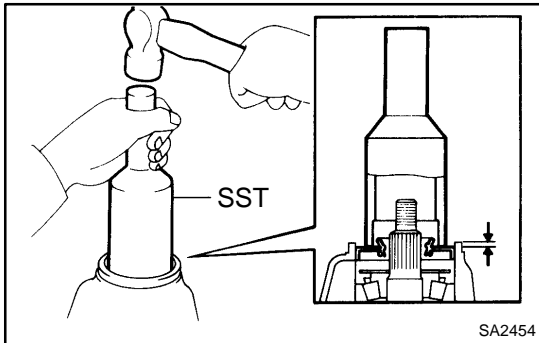

(b) Using SST and a hammer, install the oil seal.

SST 09214-7601 1

Oil seal drive in depth: 0.5 mm (0.020 in.)

(c) Coat MP grease to the oil seal lip.

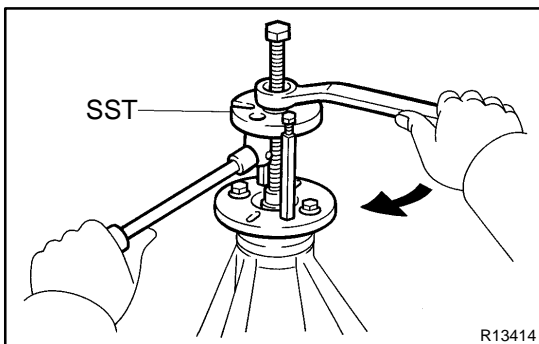
**22. INSTALL COMPANION FLANGE**

(a) Using SST, install the companion flange.

SST 09950-30012 (09951-03010, 09953-03010,
09954-03010, 09955-03030, 09956-03040)

(b) Coat the threads of a new nut with gear oil.

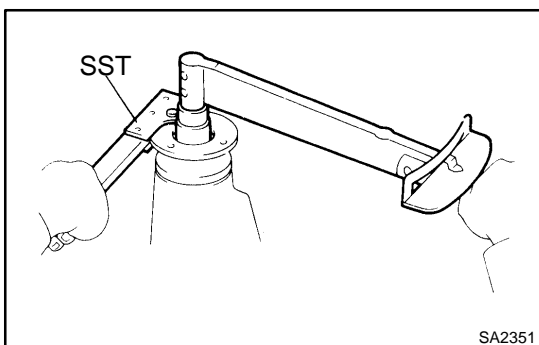

(c) Using SST to hold the flange, install the nut.

SST 09330-00021

Torque: 245 N·m (2,500 kgf·cm, 181 ft·lbf)

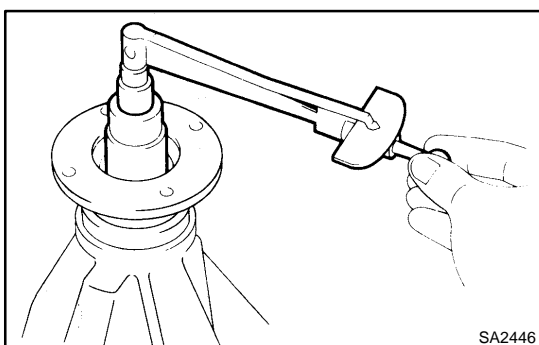
**23. ADJUST DRIVE PINION PRELOAD**

Using a torque wrench, measure the preload of the backlash between the drive pinion and ring gear.

Preload (at starting):

New bearing

1.3 - 1.8 N·m (13 - 19 kgf·cm, 11.5 - 15.9 in.-lbf)

Reused bearing

0.64 - 0.92 N·m (6.5 - 9.4 kgf·cm, 5.7 - 18.1 in.-lbf)

If the preload is greater than the specified value, replace the bearing spacer.

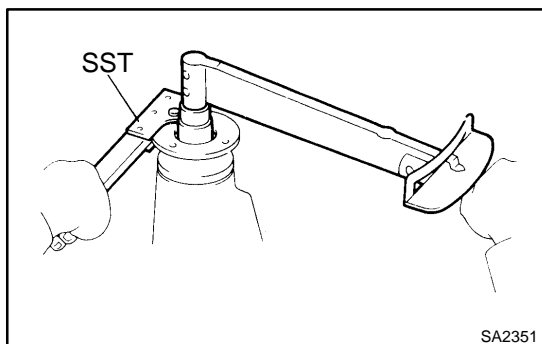

If the preload is less than the specified value, retighten the nut with a force of 13 N·m (130 kgf·cm, 9 ft·lbf) at a time until the specified preload is reached.

SST 09330-00021

Torque: 441 N·m (4,500 kgf·cm, 326 ft·lbf) or less

If the maximum torque is exceeded while retightening the nut, replace the bearing spacer and repeat the preload procedure. Do not loosen the pinion nut to reduce the preload.

24. RECHECK RING GEAR BACKLASH

(See page SA-107)

25. RECHECK TOOTH CONTACT BETWEEN RING GEAR AND DRIVE PINION (See step 14)

26. CHECK RUNOUT OF COMPANION FLANGE (See page SA-107)

27. STAKE DRIVE PINION NUT

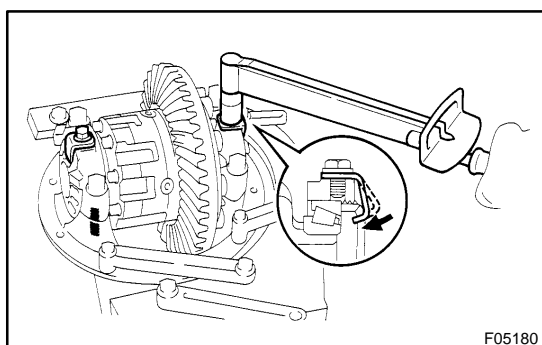

28. INSTALL ADJUSTING NUT LOCKS

- (a) Install 2 new nut locks on the bearing caps.
- (b) Tightening 2 bolts, bend the nut locks.

Torque: 13 N·m (130 kgf·cm, 9 ft·lbf)

29. REMOVE DIFFERENTIAL CARRIER FROM OVERHAUL STAND ETC.

REMOVAL

1. **REMOVE 2 REAR WHEELS**
Torque: 131 N·m (1,340 kgf·cm, 97 ft·lbf)
2. **DRAIN HYPOID GEAR OIL**
Torque: 49 N·m (500 kgf·cm, 36 ft·lbf)

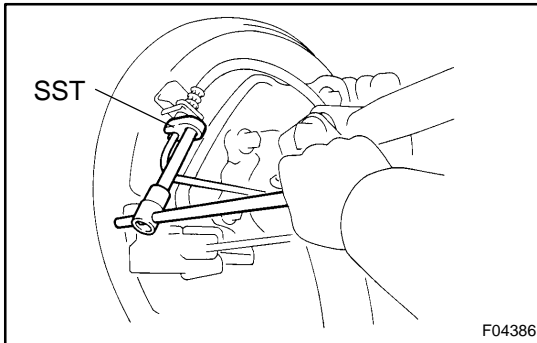

3. **DISCONNECT BRAKE LINES**
 - (a) Using SST, disconnect the brake line and remove the clip.
SST 09023-00100
Torque: 15 N·m (150 kgf·cm, 11 ft·lbf)
 - (b) Employ the same manner described above to the other side.
4. **DISCONNECT PARKING BRAKE CABLES**
 - (a) Remove the 2 clips, pin and disconnect the parking brake cable from the bellcrank.
 - (b) Employ the same manner described above to the other side.

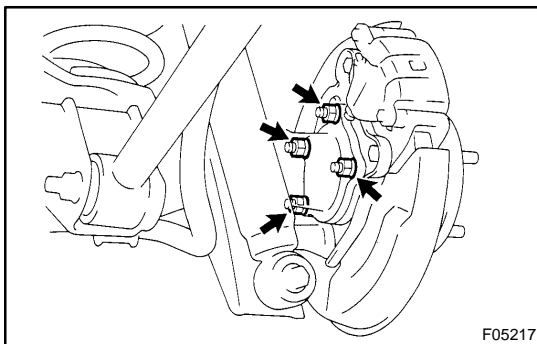

5. **REMOVE AXLE SHAFTS**
 - (a) Remove the 4 nuts.
Torque: 123 N·m (1,250 kgf·cm, 90 ft·lbf)
 - (b) Pull out the axle shaft and remove the O-ring.

NOTICE:

Be careful not to damage the oil seal.

- (c) Employ the same manner described above to the other side.

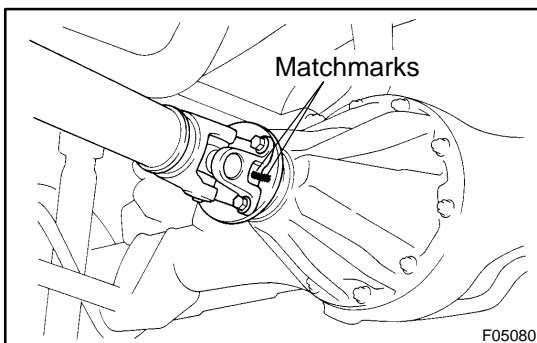

6. **DISCONNECT REAR PROPELLER SHAFT**
 - (a) Place matchmarks on the propeller shaft and differential flange.
 - (b) Remove the 4 nuts, bolts, washers and disconnect the propeller shaft.
Torque: 106 N·m (1,080 kgf·cm, 78 ft·lbf)
 - (c) Support the propeller shaft securely.

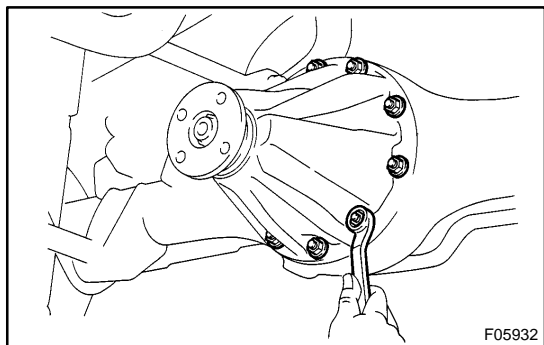
**7. REMOVE DIFFERENTIAL CARRIER ASSEMBLY**

- (a) Remove the 10 nuts, washers and differential carrier assembly.

NOTICE:

Be careful not to damage the installation surface.

Torque: 72 N·m (740 kgf·cm, 53 ft·lbf)

- (b) Remove the gasket.

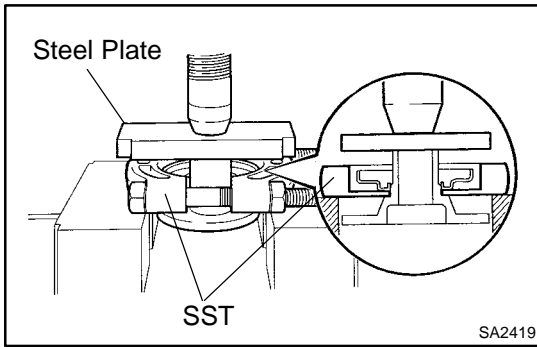

REPLACEMENT

- 1. REMOVE COMPANION FLANGE DUST DEFLECTOR**
Using SST, a steel plate and press, remove the dust deflector.
SST 09950-00020

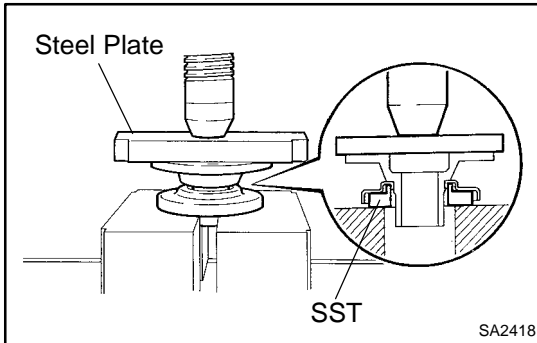

- 2. INSTALL DUST DEFLECTOR**
Using SST, a steel plate and press, install a new dust deflector.
SST 09726-40010

REAR DIFFERENTIAL CARRIER (w/ Diff. Lock) COMPONENTS

SA15S-04

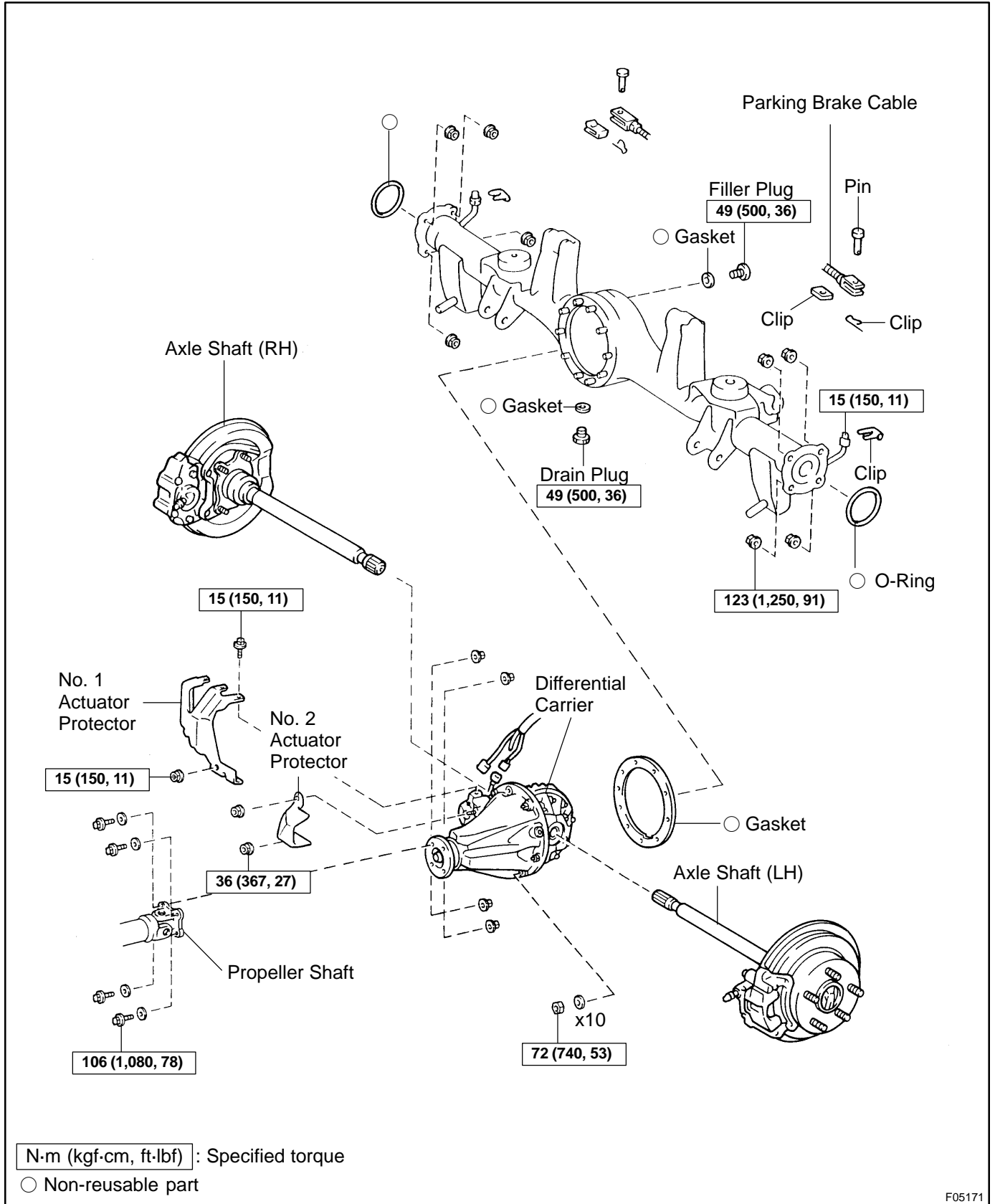

F05171

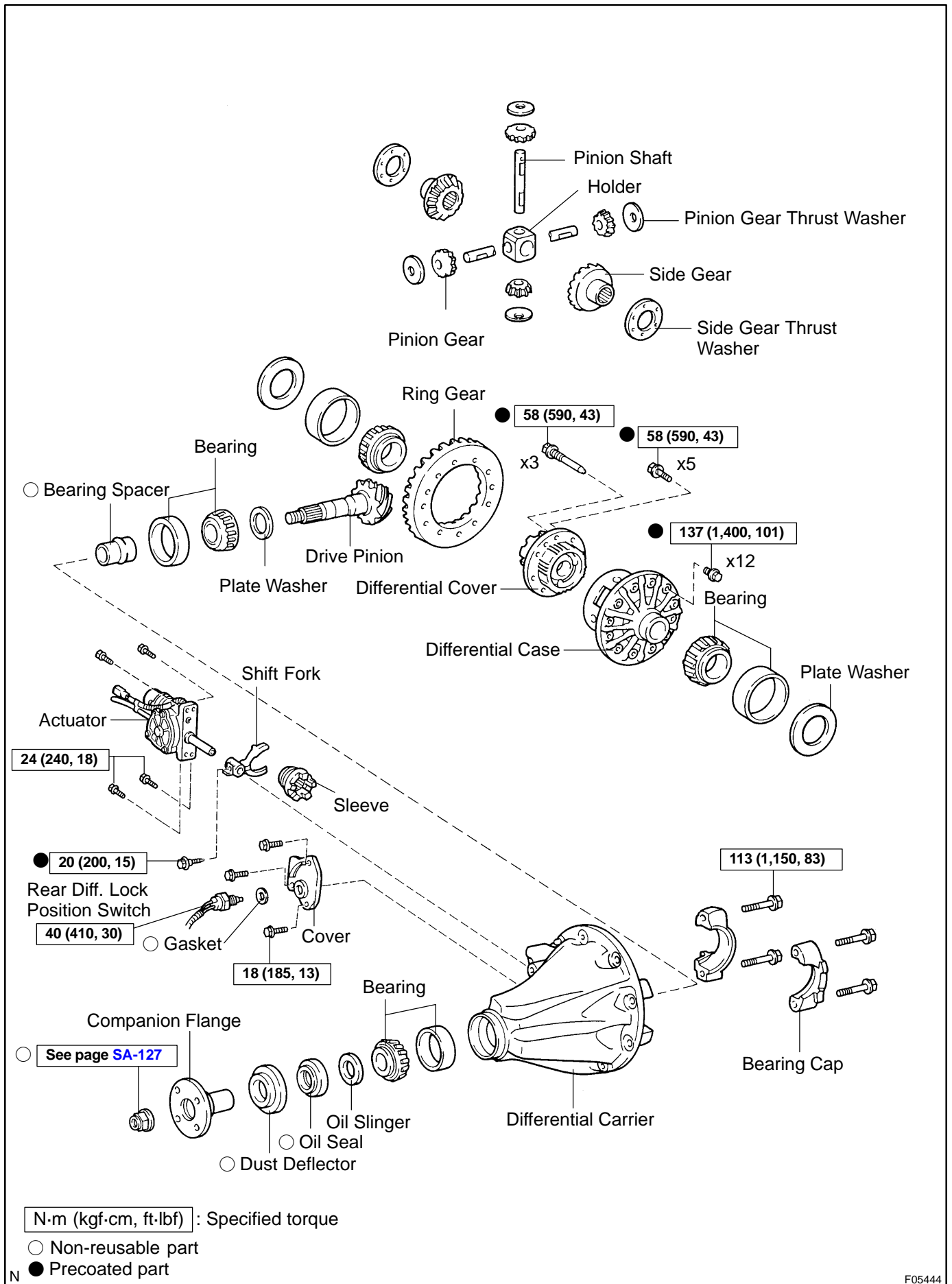

F05444

DISASSEMBLY

1. SET DIFFERENTIAL CARRIER TO OVERHAUL STAND ETC.

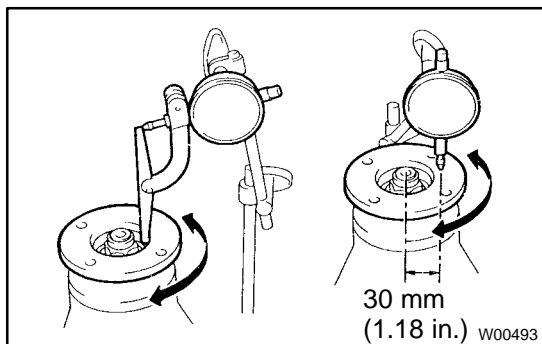

2. CHECK RUNOUT OF COMPANION FLANGE

Using a dial indicator, measure the vertical and lateral runout of the companion flange.

Maximum runout: 0.10 mm (0.0039 in.)

If the runout is greater than the maximum, replace the companion flange.

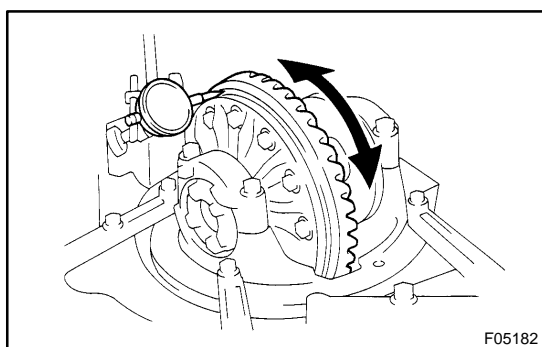

3. CHECK RING GEAR RUNOUT

Using a dial indicator, measure the ring gear runout.

Maximum runout: 0.05 mm (0.0020 in.)

If the runout is greater than the maximum, replace the ring gear.

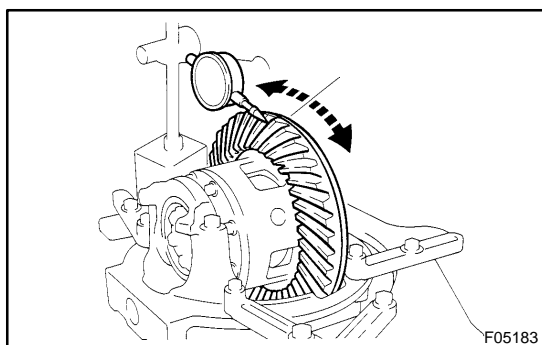

4. CHECK RING GEAR BACKLASH

Using a dial indicator, while holding the drive pinion flange, measure the ring gear backlash.

Backlash: 0.13 - 0.18 mm (0.0051 - 0.0071 in.)

HINT:

Perform the measurements at 3 or more positions around the circumference of the ring gear.

If the backlash is not within the specified value, adjust the side bearing preload or repair as necessary.

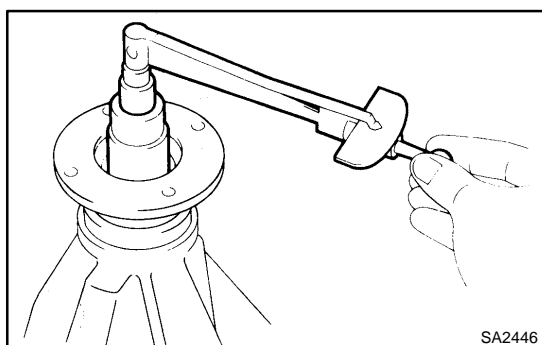

5. MEASURE DRIVE PINION PRELOAD

Using a torque wrench, measure the drive pinion preload using the backlash of the drive pinion and ring gear.

Preload (at starting):

0.64 - 0.92 N·m (6.5 - 9.4 kgf·cm, 5.7 - 8.1 in.-lbf)

6. CHECK TOTAL PRELOAD

Using a torque wrench, measure the preload with the teeth of the drive pinion and ring gear in contact.

Total preload (at starting):**Drive pinion preload plus**

0.3 - 0.5 N·m (3 - 5 kgf·cm, 2.7 - 4.4 in.-lbf)

If necessary, disassemble and inspect the differential.

7. CHECK TOOTH CONTACT BETWEEN RING GEAR AND DRIVE PINION (See page SA-127)**8. REMOVE REAR DIFF. LOCK POSITION SWITCH**

Remove the rear diff. lock position switch and gasket.

9. REMOVE COVER

- (a) Remove the 3 bolts.
- (b) Using a brass bar and hammer, tap on the cover to remove it.

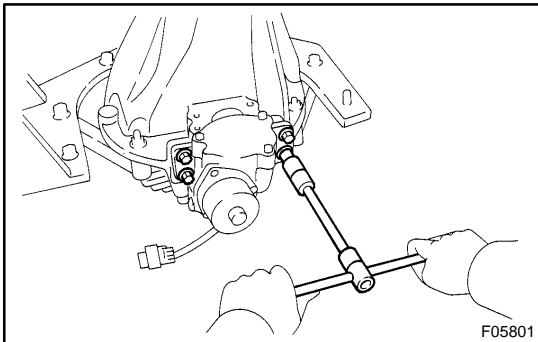
**10. REMOVE ACTUATOR, SHIFT FORK AND SLEEVE**

- (a) Remove the 4 bolts.

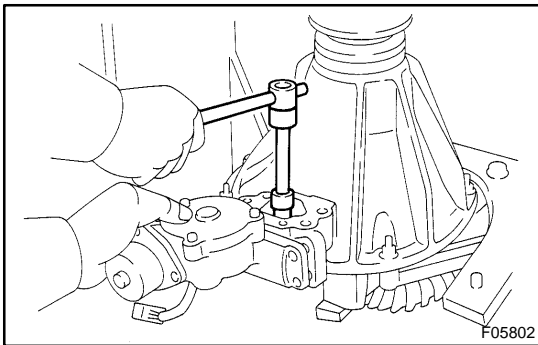

- (b) Remove the shift fork shaft bolt.
- (c) Using a screwdriver, pull out the actuator and remove the sleeve and shift fork.

11. REMOVE COMPANION FLANGE

- (a) Using a chisel and hammer, unstake the nut.

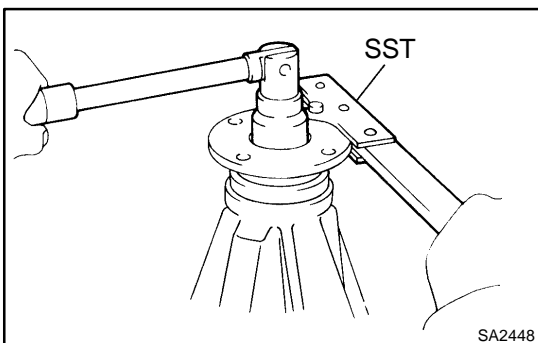

- (b) Using SST to hold the flange, remove the nut.
SST 09330-00021

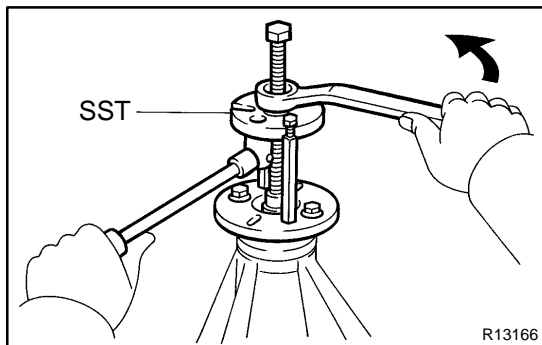

- (c) Using SST, remove the companion flange.
SST 09950-30012 (09951-03010, 09953-03010, 09954-03010, 09955-03030, 09956-03040)

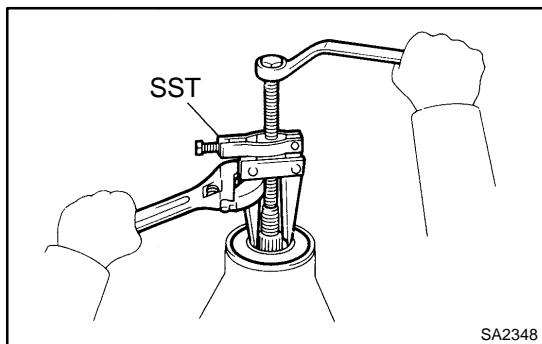

12. REMOVE OIL SEAL AND OIL SLINGER

- (a) Using SST, remove the oil seal from the differential carrier.
SST 09308-10010
(b) Remove the oil slinger.

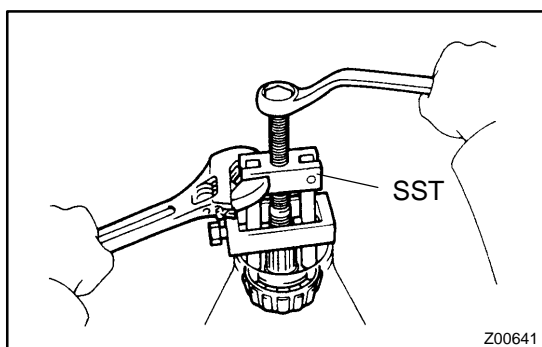

13. REMOVE FRONT BEARING

- Using SST, remove the front bearing from the drive pinion.
SST 09556-22010
If the front bearing is damaged or worn, replace the bearing.

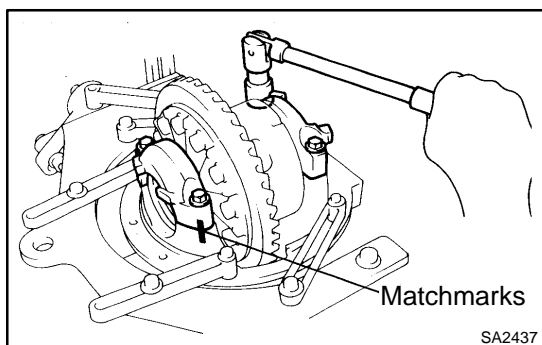

14. REMOVE DIFFERENTIAL CASE ASSEMBLY

- (a) Place matchmarks on the bearing cap and differential carrier.
(b) Remove the 4 bolts and 2 bearing caps.

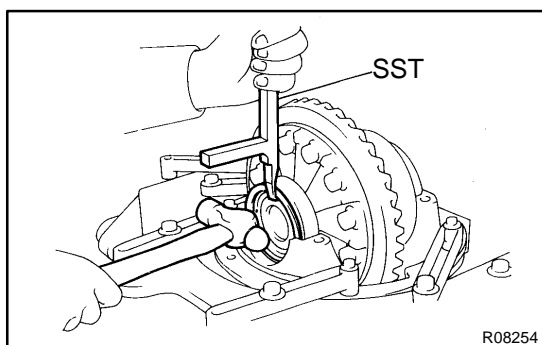

- (c) Using SST and a hammer, remove the plate washers.
SST 09504-22012

HINT:

Measure the plate thickness and note down it.

- (d) Remove the differential case with the side bearing outer races from the differential carrier.

HINT:

Tag the bearing outer races to show the location for reassembling.

15. REMOVE DRIVE PINION AND BEARING SPACER FROM DIFFERENTIAL CARRIER

- (a) Remove the drive pinion with the rear bearing.
- (b) Remove the bearing spacer.

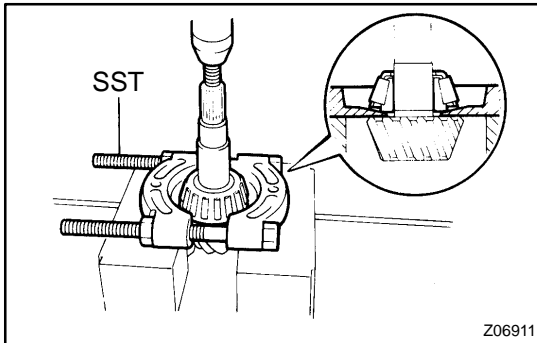
**16. REMOVE DRIVE PINION REAR BEARING**

- (a) Using SST and a press, remove the rear bearing from the drive pinion.
SST 09950-00020

HINT:

If the drive pinion or ring gear is damaged, replace them as a set.

- (b) Remove the plate washer from the drive pinion.

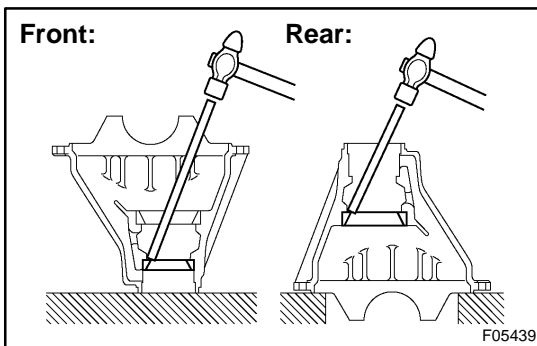
**17. REMOVE FRONT AND REAR BEARING OUTER RACES**

Using a brass bar and hammer, remove the outer races.

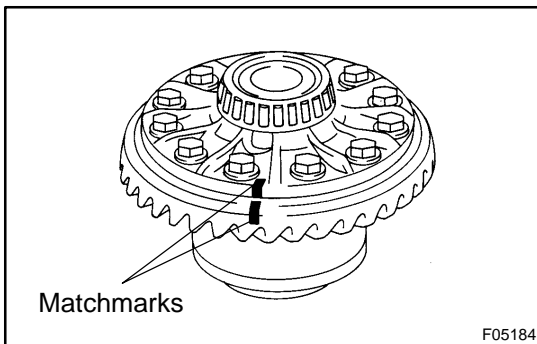
**18. REMOVE RING GEAR**

- (a) Place matchmarks on the ring gear and differential case.
- (b) Remove the 12 ring gear set bolts.
- (c) Using a plastic hammer, tap on the ring gear to remove it from the differential case.

19. CHECK DIFFERENTIAL CASE RUNOUT

- (a) Place the bearing outer races on their respective bearings. Check that the right and left outer races are not interchanged.
- (b) Install the assembled plate washers onto the side bearing.
- (c) Install the differential case in the differential carrier.

HINT:

If it is difficult to install the differential case into the carrier, replace the plate washer with a thinner one.

However, select a plate washer that allows no clearance between it and the carrier.

- (d) Align the matchmarks on the bearing cap and differential carrier.
- (e) Install and uniformly tighten the 4 bolts a little at a time.

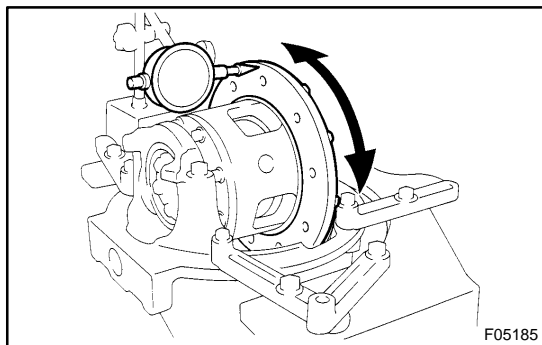

(f) Using a dial indicator, measure the differential case runout.

Maximum case runout: 0.04 mm (0.0016 in.)

(g) Remove the differential case.

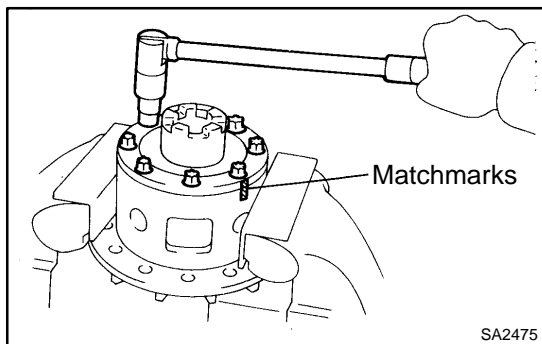

20. DISASSEMBLE DIFFERENTIAL CASE

(a) Place matchmarks on the case and cover.

(b) Using a torx socket (E10), remove the 5 set bolts and 3 pinion shaft pins.

(c) Separate the cover and case.

(d) Remove the 2 side gears, side gear thrust washers, 4 pinion gears, pinion gear thrust washers, 3 pinion shafts and holder from the differential case.

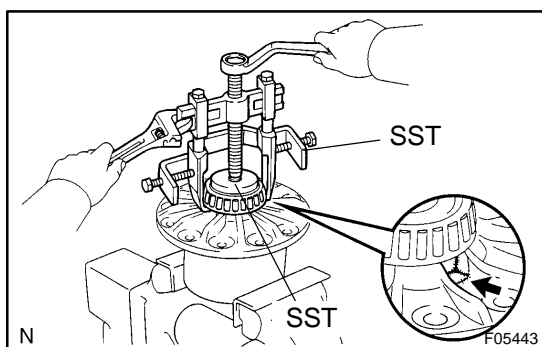

21. REMOVE SIDE BEARING FROM DIFFERENTIAL CASE

Using SST, remove the side bearing.

SST 09950-40011 (09951-04010, 09952-04010, 09953-04020, 09955-04061, 09957-04010, 09958-04011), 09950-60010 (09951-00580)

HINT:

Fix the claws of SST to the notches in the differential case.

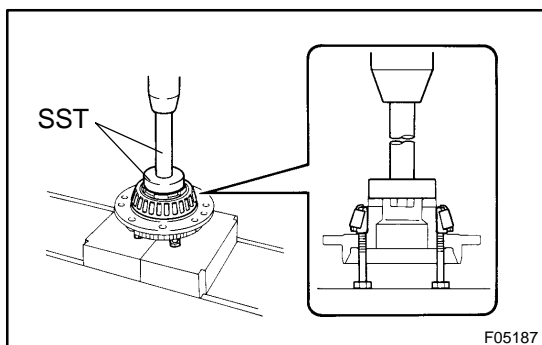

22. REMOVE SIDE BEARING FROM DIFFERENTIAL COVER

Using SST, 4 bolts and a press, remove the side bearing.

SST 09950-60010 (09951-00580),
09950-70010 (09951-07100)

INSTALLATION

Installation is in the reverse order of removal (See page [SA-100](#)).

AFTER INSTALLATION, FILL DIFFERENTIAL WITH HYPOID GEAR OIL (See page [SA-95](#))

HINT:

After installation, fill the differential with hypoid gear oil (See page [SA-95](#)), fill the brake reservoir with brake fluid, bleed the brake system (See page [BR-4](#)), check for leaks and check the ABS speed sensor signal (See page [DI-505](#)).

REASSEMBLY

HINT:

- Using a shop rag, clean off any foreign object from the parts.
- Apply all of the sliding and rotating surfaces with hypoid gear oil.

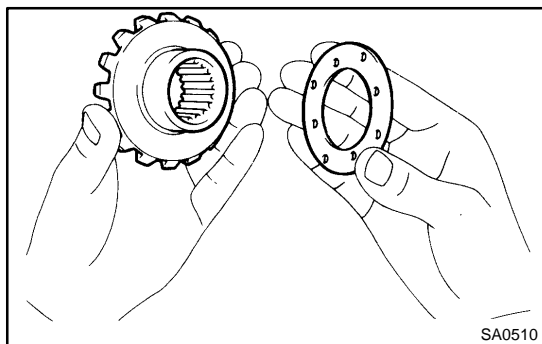

1. MEASURE SIDE GEAR BACKLASH

- (a) Install the 2 thrust washers to the 2 side gears.
- (b) Install the 4 thrust washers to the 4 pinion gears.

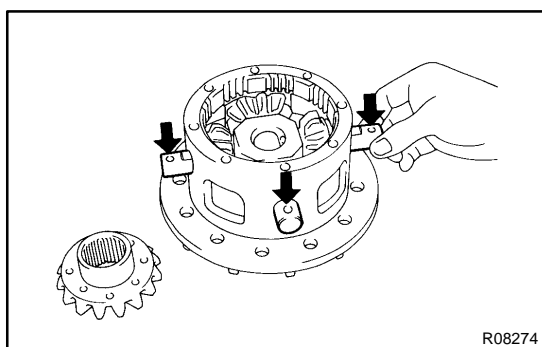

- (c) Install the side gear into the case.
- (d) Install the holder into the case.
- (e) Install the 4 pinion gears with the thrust washers.
- (f) Align the holes of the differential case and pinion shaft, and install the 3 pinion shafts.
- (g) Install the side gear to the cover.
- (h) Align the matchmarks and install the case and cover.
- (i) Using a torx socket (E10), install the 5 bolts and 3 pinion shaft pins.

Torque: 58 N·m (590 kgf·cm, 43 ft·lbf)

- (j) Using a dial indicator, while holding the side gear, measure the backlash.

Backlash: 0.02 - 0.15 mm (0.0008 - 0.0059 in.)

If the backlash is not within the specified value, install the thrust washer of a different thickness.

HINT:

- Try to select washers of the same size for both sides.
- Measure at all 4 locations.

Thrust washer thickness:

Thickness mm (in.)	Thickness mm (in.)
1.55 (0.061)	1.85 (0.073)
1.60 (0.063)	1.90 (0.075)
1.65 (0.065)	1.95 (0.077)
1.70 (0.067)	2.00 (0.079)
1.75 (0.069)	2.05 (0.081)
1.80 (0.071)	2.10 (0.083)

- (k) After measuring backlash, remove the 5 set bolts and 3 pinion shaft pins.

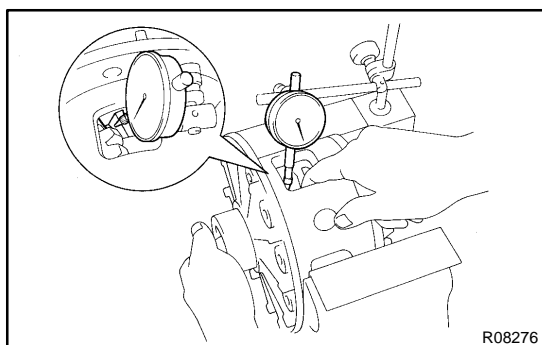

2. ASSEMBLE DIFFERENTIAL CASE

- (a) Clean the threads of the bolts, pinion shaft pins, case and cover with the white gasoline.

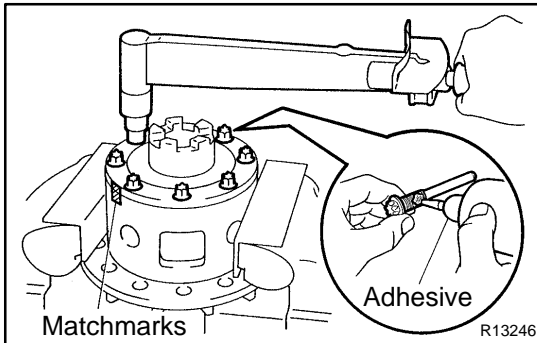

- (b) Coat the threads of the bolts and pinion shaft with adhesive.

Adhesive:

Part No. 08833-00070, THREE BOND 1324 or equivalent

- (c) Align the matchmarks, install the case and cover.
 (d) Using a torx socket (E10), install the 5 bolts and 3 pinion shaft pins.

Torque: 58 N·m (590 kgf-cm, 43 ft-lbf)

3. INSTALL SIDE BEARINGS

- (a) Cover side:

Using SST and a press, install the side bearing on the differential cover.

SST 09550-60010

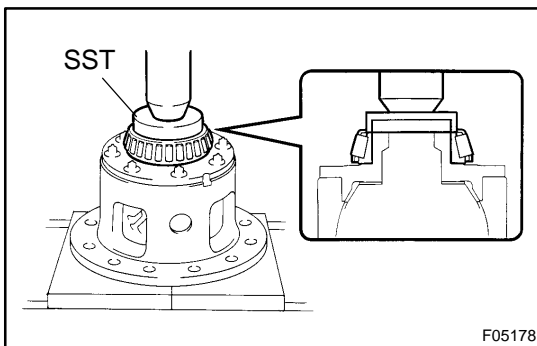

- (b) Ring gear side:

Using SST and a press, install the side bearing on the differential case.

SST 09550-60010

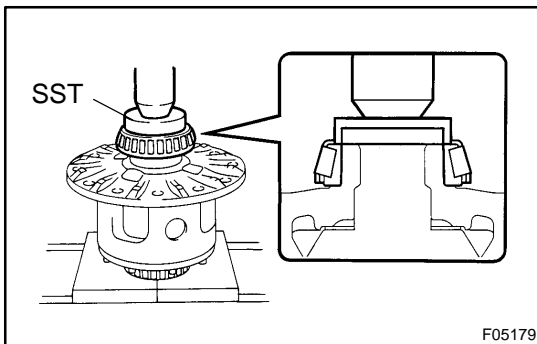
**4. INSTALL RING GEAR ON DIFFERENTIAL CASE**

- (a) Clean the threads of the bolts and differential case with the white gasoline.

- (b) Clean the contact surfaces of the differential case and ring gear.

- (c) Heat the ring gear to about 100 °C (212 °F) in boiling water.

- (d) Carefully take the ring gear out of the boiling water.

- (e) After the moisture on the ring gear has completely evaporated, quickly install the ring gear on the differential case.

- (f) Align the matchmarks on the ring gear and differential case.

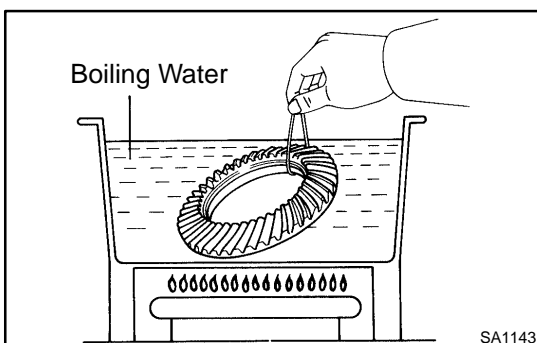

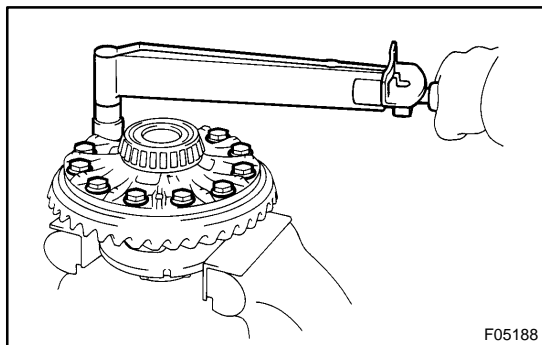

- (g) Temporarily install the 12 set bolts.
- (h) After the ring gear has cooled down enough, torque the 12 set bolts to which thread lock has been applied.

Thread lock:

**Part No.08833-00100, THREE BOND 1360K
or equivalent**

Torque: 137 N·m (1,400 kgf·cm, 101 ft·lbf)

5. CHECK RING GEAR RUNOUT

- (a) Place the bearing outer races on their respective bearings. Check that the right and left outer races are not interchanged.
- (b) Install the assembled plate washers onto the side bearing.
- (c) Install the differential case in the differential carrier.

HINT:

If it is difficult to install the differential case into the carrier, replace the plate washer with a thinner one.

However, select a plate washer that allows no clearance between it and the carrier.

- (d) Align matchmarks on the bearing cap and differential carrier.
- (e) Install and uniformly tighten the 4 bolts a little at a time.

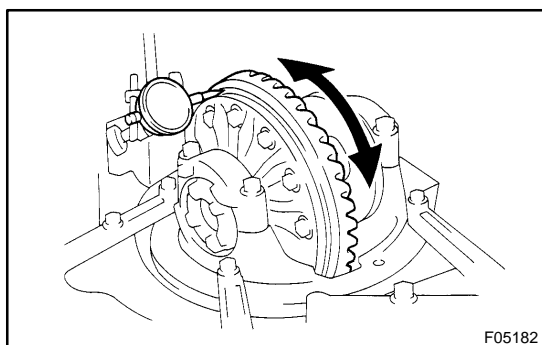

- (f) Using a dial indicator, check the ring gear runout.
Maximum runout: 0.05 mm (0.0020 in.)
- (g) Remove the differential case.

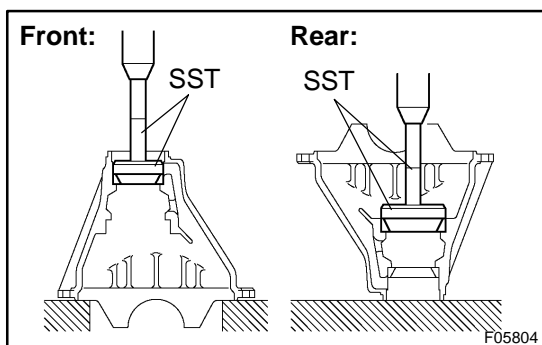
**6. INSTALL DRIVE PINION FRONT AND REAR BEARING OUTER RACES**

- (a) Using SST and a press, install the front bearing outer race.
SST 09950-60020 (09951-00710),
09950-70010 (09951-07150)
- (b) Using SST and a press, install the rear bearing outer race.
SST 09950-60020 (09951-00890),
09950-70010 (09951-07150)

7. INSTALL DRIVE PINION REAR BEARING

- (a) Install the plate washer on the drive pinion.

HINT:

First fit a washer with the same thickness as the washer which was removed, then after checking the tooth contact pattern, replace the washer with one of a different thickness if necessary.

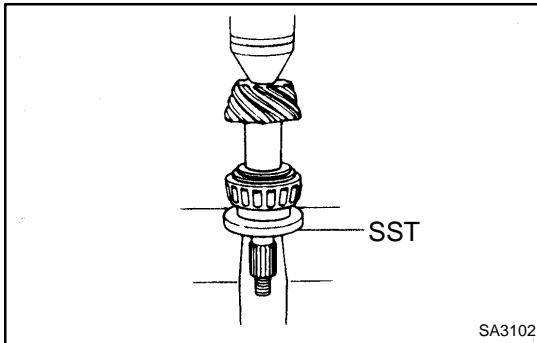

- (b) Using SST and a press, install the rear bearing onto the drive pinion.

SST 09506-35010

8. TEMPORARILY ADJUST DRIVE PINION PRELOAD

- (a) Install the drive pinion and front bearing.

HINT:

Assemble the spacer and oil seal after adjusting the gear contact pattern.

- (b) Install the oil slinger.

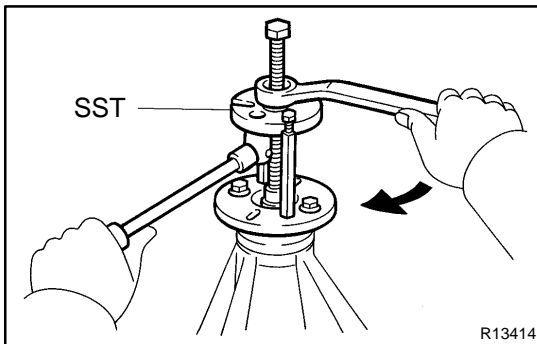

- (c) Install the companion flange with SST.

SST 09950-30012 (09951-03010, 09953-03010, 09954-03010, 09955-03030, 09956-03040)

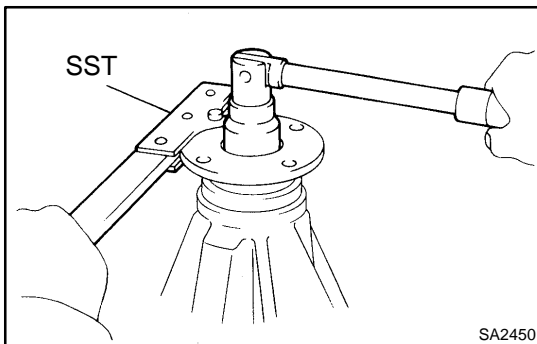

- (d) Using SST to hold the flange and adjust the drive pinion preload by tightening the companion flange nut.

SST 09330-00021

NOTICE:

- Coat the nut and screw of the drive pinion with gear oil.
- As there is no spacer, tighten the nut a little at a time, being careful not to overtighten.

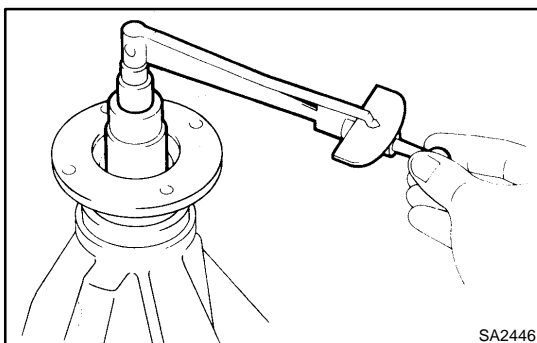

- (e) Using a torque wrench, measure the preload.

Preload (at starting):**New bearing**

1.3 - 1.8 N·m (13 - 19 kgf·cm, 11.5 - 15.9 in.-lbf)

Reused bearing

0.64 - 0.92 N·m (6.5 - 9.4 kgf·cm, 5.7 - 8.1 in.-lbf)

HINT:

Measure the total preload after turning the bearing clockwise and counterclockwise several times to make the bearing smooth.

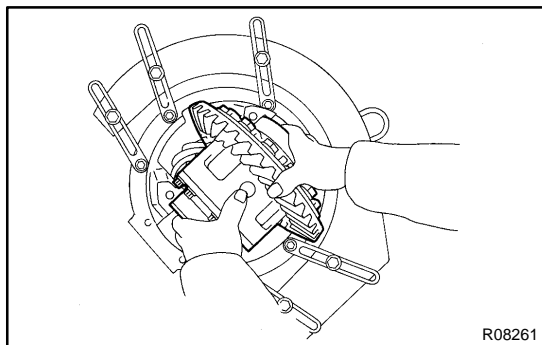

9. INSTALL DIFFERENTIAL CASE IN CARRIER

- (a) Place the 2 bearing outer races on their respective bearings. Make sure that the right and left races are not interchanged.
- (b) Install the assembled plate washer onto the side bearing.
- (c) Install the differential case in the carrier.

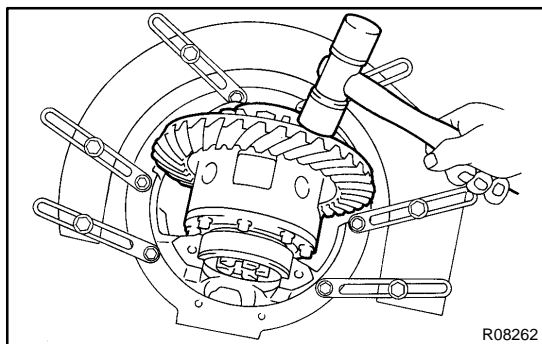

- (d) Settle down the plate washer and bearing snugly by tapping on the ring gear with a plastic hammer.

HINT:

If it is difficult to install the differential case into the carrier, replace the plate washer with a thinner one.

However, select a plate washer that allows no clearance between it and the carrier.

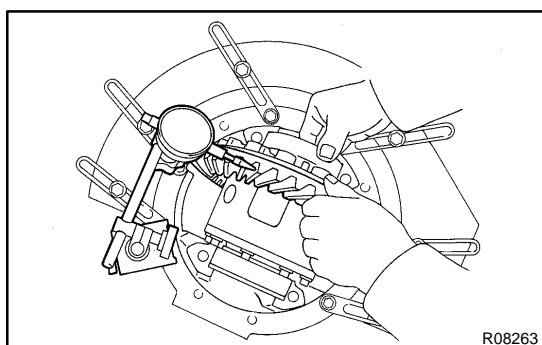

10. ADJUST RING GEAR BACKLASH

- (a) Using a dial indicator, while holding the side bearing of the ring gear side measure the backlash.

Backlash (Reference): 0.15 mm (0.0059 in.)

- (b) Select a cover side plate washer using the backlash as a reference.

Plate washer thickness:

Mark	Thickness mm (in.)	Mark	Thickness mm (in.)
1	2.67 (0.1051)	13	3.03 (0.1193)
2	2.70 (0.1063)	14	3.06 (0.1205)
3	2.73 (0.1075)	15	3.09 (0.1217)
4	2.76 (0.1087)	16	3.12 (0.1228)
5	2.79 (0.1098)	17	3.15 (0.1240)
6	2.82 (0.1110)	18	3.18 (0.1252)
7	2.85 (0.1122)	19	3.21 (0.1264)
8	2.88 (0.1134)	20	3.24 (0.1276)
9	2.91 (0.1146)	21	3.27 (0.1287)
10	2.94 (0.1157)	22	3.30 (0.1299)
11	2.97 (0.1169)	23	3.33 (0.1311)
12	3.00 (0.1181)	-	-

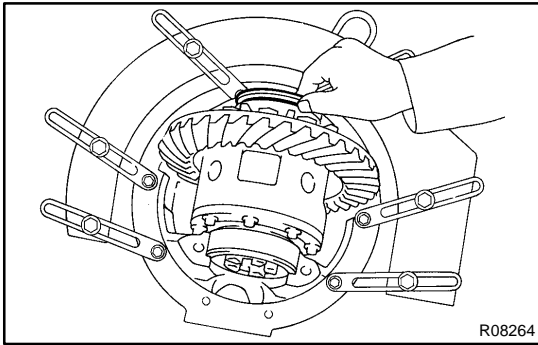

- (c) Select a ring gear side plate washer so that there is no clearance between the outer race and case.

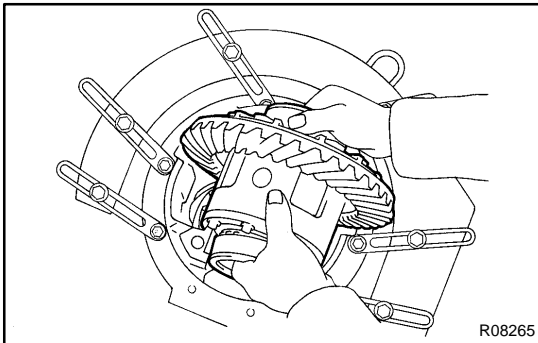

- (d) Remove the 2 plate washers and differential carrier.
 (e) Install the plate washer into the lower part of the carrier.
 (f) Place the plate washer onto the differential case together with the outer races, and install the differential case with the outer race into the carrier.
 (g) Settle down the plate washer and bearing snugly by tapping on the ring gear with a plastic hammer.

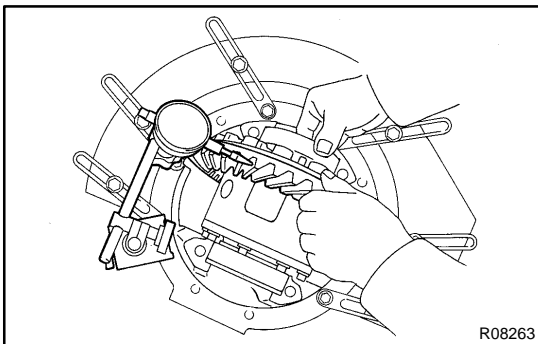

- (h) Using a dial indicator, measure the ring gear backlash.
Backlash: 0.13 - 0.18 mm (0.0051 - 0.0071 in.)

If it is not within the specified value, adjust it by either increasing or decreasing the thickness of washers on both sides by an equal amount.

HINT:

There should be no clearance between the plate washer and case.

Ensure that there is ring gear backlash.

11. ADJUST SIDE BEARING PRELOAD

- (a) After adjustment using the backlash as reference, remove the ring gear side plate washer.

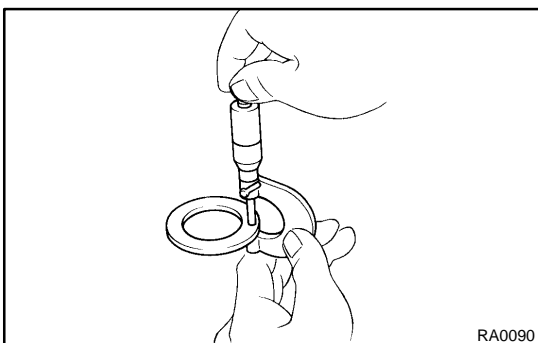

- (b) Using a micrometer, measure the thickness of the removed plate washer.
 (c) Install a new washer 0.06 - 0.09 mm (0.0024 - 0.0035 in.) thicker than the removed washer.

HINT:

Select a washer which can be pressed in 2/3 of the way with finger.

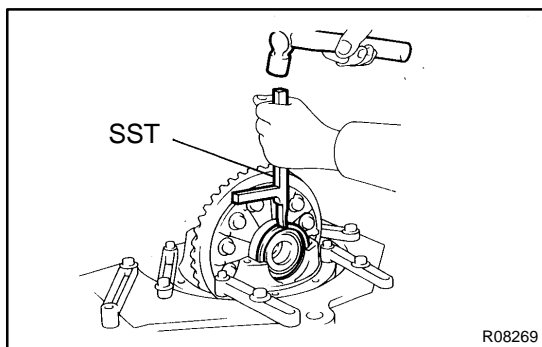

- (d) Using SST, tap in the plate washer.
SST 09504-22012
- (e) Align the matchmarks on the cap and carrier.
- (f) Tighten the 4 bearing cap bolts to the specified torque.
Torque: 113 N·m (1,150 kgf·cm, 83 ft·lbf)

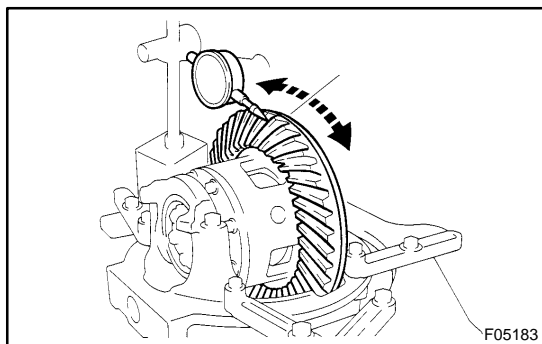

- (g) Using a dial indicator, measure the ring gear backlash until it is within the specified value.
Backlash: 0.13 - 0.18 mm (0.0051 - 0.0071 in.)
If the backlash is not within the specified value, adjust by either increasing or decreasing the thickness of washers on both sides by an equal amount.
- (h) After rotating the ring gear 5 turns or more, recheck the ring gear backlash.

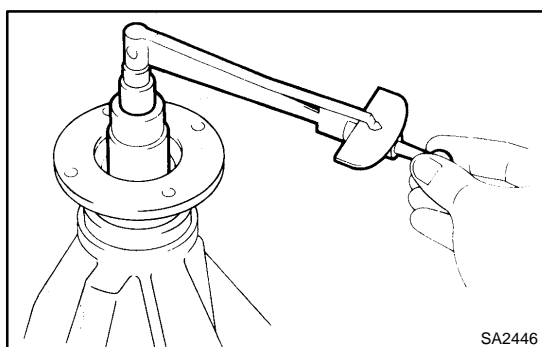

12. MEASURE TOTAL PRELOAD

Using a torque wrench, measure the preload with the teeth of the drive pinion and ring gear in contact.

Preload (at starting):

Drive pinion preload plus

0.3 - 0.5 N·m (3 - 5 kgf·cm, 2.7 - 4.4 in·lbf)

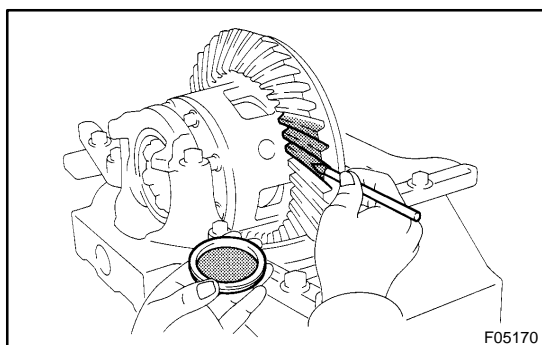

13. INSPECT TOOTH CONTACT BETWEEN RING GEAR

- (a) Coat 3 or 4 teeth at 3 different positions on the ring gear with red lead primer.
- (b) Turn the companion flange, in both directions to inspect the ring gear for proper tooth contact.

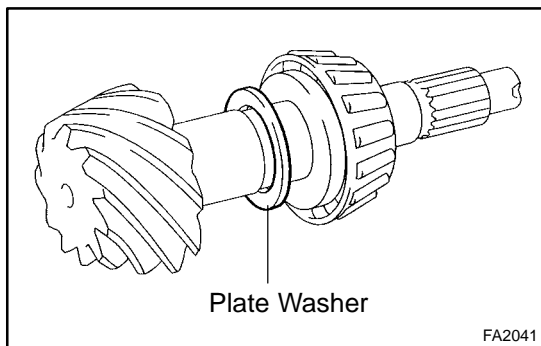
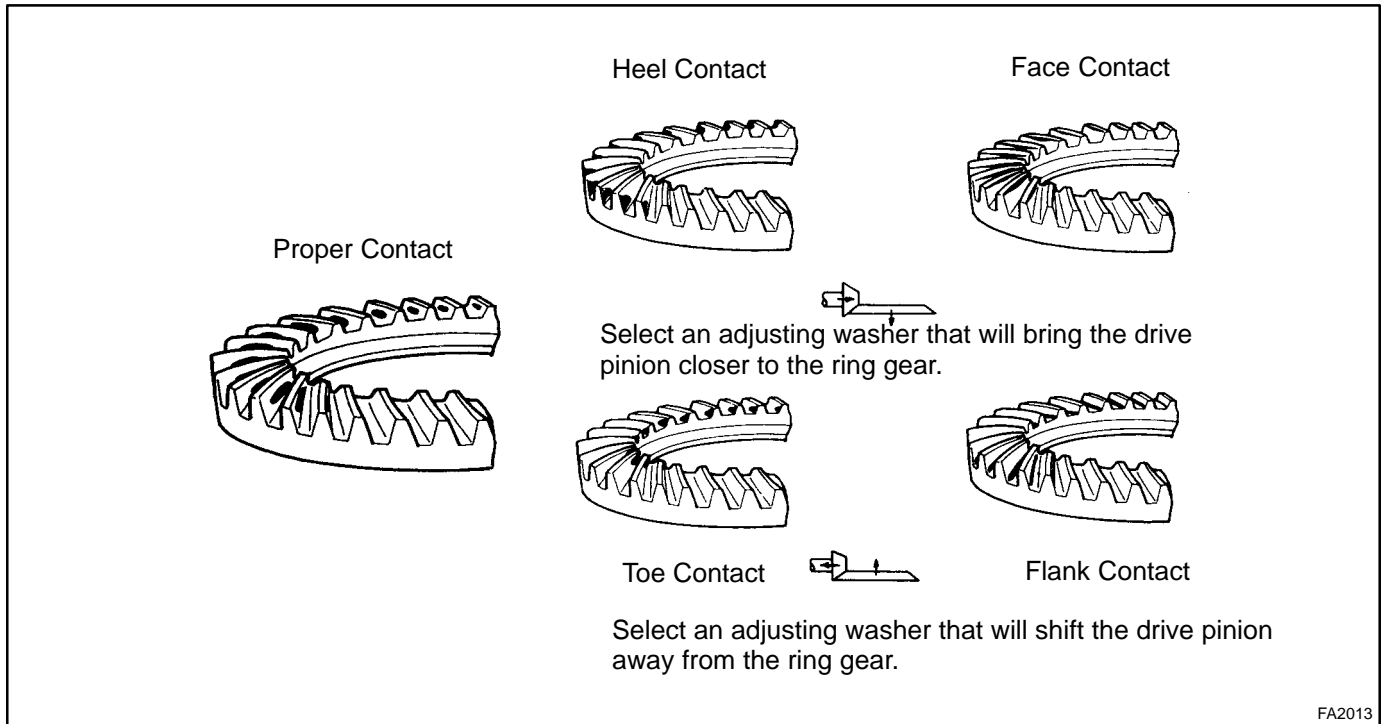

If the teeth are not contacting properly, use the following table to select a proper washer for correction.

Plate washer thickness:

Thickness mm (in.)	Thickness mm (in.)
1.050 (0.04134)	1.325 (0.05217)
1.075 (0.04232)	1.350 (0.05315)
1.100 (0.04331)	1.375 (0.05413)
1.125 (0.04429)	1.400 (0.05512)
1.150 (0.04528)	1.425 (0.05610)
1.175 (0.04626)	1.450 (0.05709)
1.200 (0.04724)	1.475 (0.05807)
1.225 (0.04823)	1.500 (0.05906)
1.250 (0.04921)	1.525 (0.06004)
1.275 (0.05020)	1.550 (0.06102)
1.300 (0.05118)	-

- 14. REMOVE COMPANION FLANGE (See page SA-121)
- 15. REMOVE OIL SLINGER AND FRONT BEARING (See page SA-121)

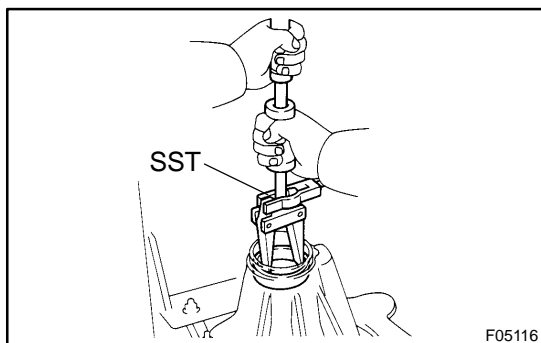

- 16. REMOVE BEARING OUTER RACE
Using SST, remove the bearing outer race.
SST 09308-00010
- 17. INSTALL NEW BEARING SPACER

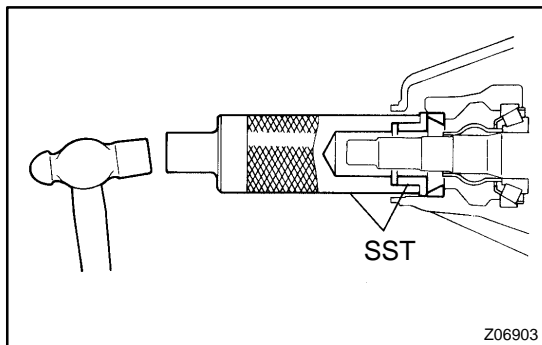
**18. INSTALL BEARING OUTER RACE**

Using SST and a hammer, install the bearing outer race.

SST 09316-6001 1 (09316-00011, 09316-00021)

19. INSTALL FRONT BEARING AND OIL SLINGER**20. INSTALL OIL SEAL**

(a) Coat the hypoid gear oil to a new oil seal periphery.

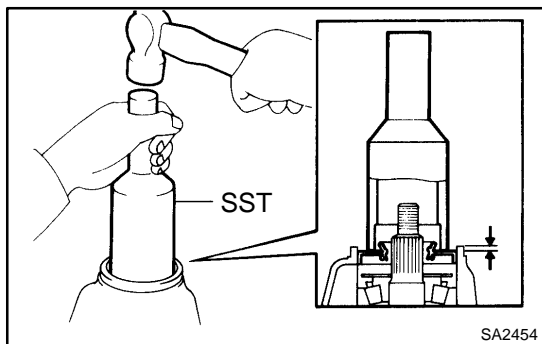

(b) Using SST and a hammer, install the oil seal, as shown.
SST 09214-7601 1

Oil seal drive in depth: 0.5 mm (0.020 in.)

(c) Coat MP grease to the oil seal lip.

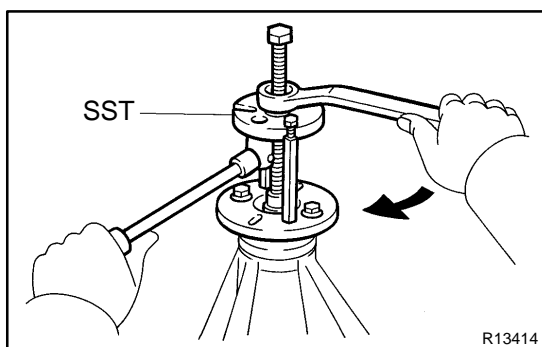
**21. INSTALL COMPANION FLANGE**

(a) Using SST, install the companion flange.

SST 09950-30012 (09951-03010, 09953-03010,
09954-03010, 09955-03030, 09956-03040)

(b) Coat the threads of a new nut with gear oil.

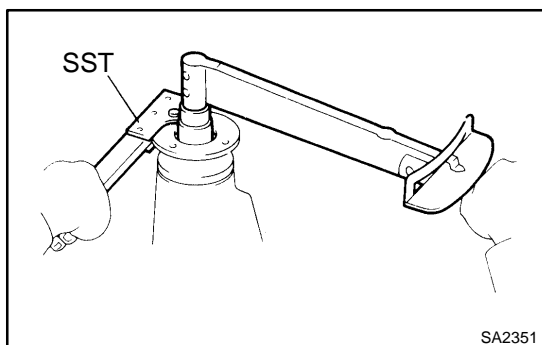

(c) Using SST to hold the flange, install the nut.

SST 09330-00021

Torque: 245 N·m (2,500 kgf·cm, 181 ft·lbf)

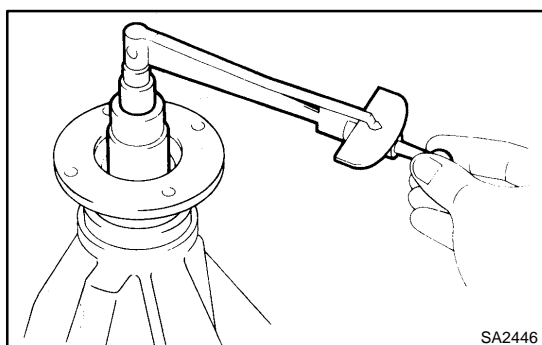
**22. ADJUST DRIVE PINION PRELOAD**

Using a torque wrench, measure the preload of the backlash between the drive pinion and ring gear.

Preload (at starting):

New bearing

1.3 - 1.8 N·m (13 - 19 kgf·cm, 11.5 - 15.9 in.-lbf)

Reused bearing

0.64 - 0.92 N·m (6.5 - 9.4 kgf·cm, 5.7 - 8.1 in.-lbf)

If the preload is greater than the specified value, replace the bearing spacer.

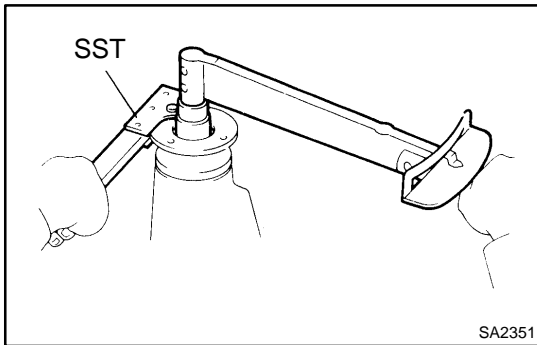

If the preload is less than the specified value, retighten the nut with a force of 13 N·m (130 kgf·cm, 9 ft·lbf) at a time until the specified preload is reached.

SST 09330-00021

Torque: 441 N·m (4,500 kgf·cm, 326 ft·lbf) or less

If the maximum torque is exceeded while retightening the nut, replace the bearing spacer and repeat the preload procedure. Do not loosen the pinion nut to reduce the preload.

23. RECHECK RING GEAR BACKLASH

(See page SA-121)

24. RECHECK TOOTH CONTACT BETWEEN RING GEAR AND DRIVE PINION (See step 13)

25. CHECK RUNOUT OF COMPANION FLANGE (See page SA-121)

26. STAKE DRIVE PINION NUT

27. INSTALL ACTUATOR, SHIFT FORK AND SLEEVE

(a) Clean contacting surfaces of any FIPG material using gasoline or alcohol.

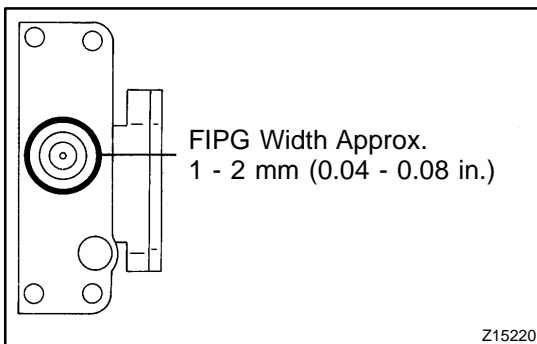

(b) Apply FIPG to the actuator.

FIPG:

Part No. 08826-00090, THREE BOND 1281 or equivalent

HINT:

Install the actuator within 10 minutes after applying FIPG.

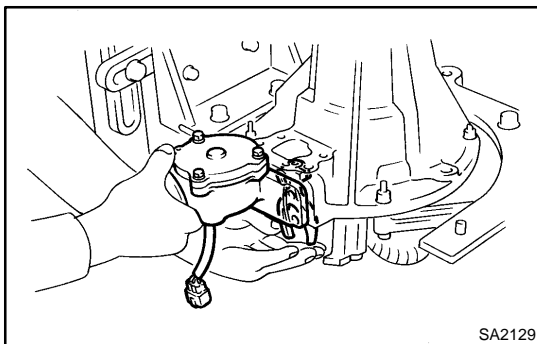

(c) Install the shift fork and actuator to the differential and match the shift fork hole with the shift fork.

(d) Clean the threads of the set bolt and fork shaft with the white gasoline.

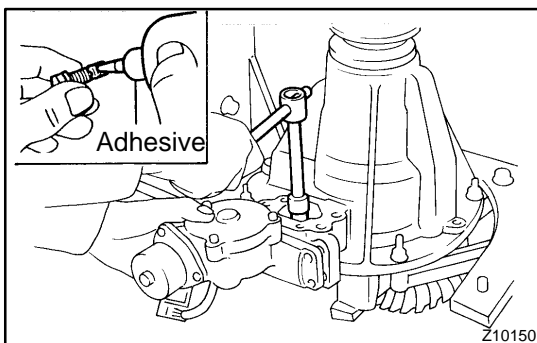

(e) Coat the threads of the set bolt with adhesive.

Adhesive:

Part No. 08833-00070, THREE BOND 1324 or equivalent

(f) Install the shift fork shaft set bolt.

Torque: 20 N·m (200 kgf·cm, 15 ft·lbf)

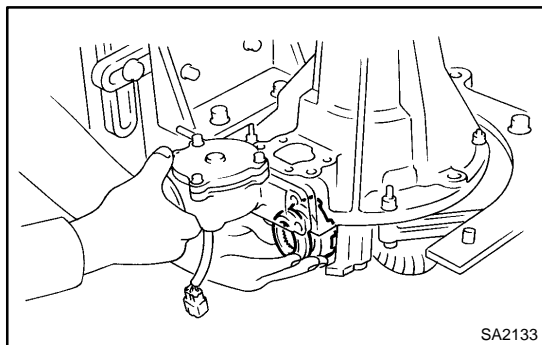

- (g) Engage the sleeve with the dog clutch of the differential case.

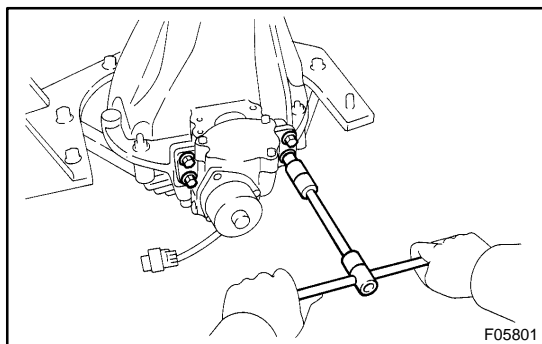

- (h) Install the 4 bolts.
Torque: 24 N·m (240 kgf-cm, 18 ft-lbf)

28. INSTALL COVER

- (a) Clean contacting surfaces of any FIPG material using gasoline or alcohol.

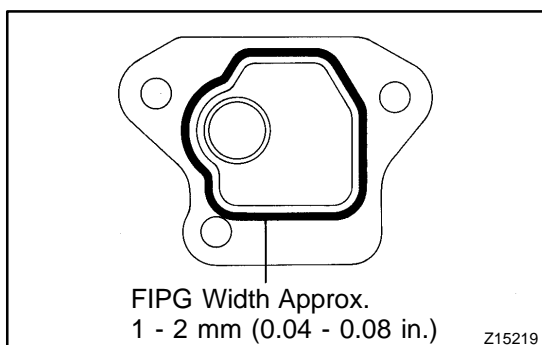

- (b) Apply FIPG to the cover.

FIPG:

Part No. 08826-00090, THREE BOND 1281 or equivalent

HINT:

Install the cover within 10 minutes after applying FIPG.

- (c) Install the cover with the 3 bolts.

Torque: 18 N·m (185 kgf-cm, 13 ft-lbf)

29. INSTALL REAR DIFF. LOCK POSITION SWITCH

Install the rear diff. lock position switch with a new gasket.

Torque: 40 N·m (410 kgf-cm, 30 ft-lbf)

30. REMOVE DIFFERENTIAL CARRIER FROM OVERHAUL STAND, ETC.

REMOVAL

1. SHIFTING REAR DIFF. LOCK

- (a) Turn the ignition switch to the ON position.
- (b) Shift the transfer shift lever to L position.

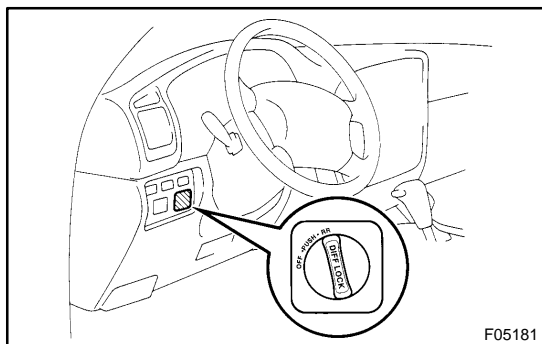

- (c) Turn the differential lock control switch to the RR position and lock the rear differential.

HINT:

While rotating the tires, check they are in the differential lock condition.

- (d) Disconnect the cable from the negative terminal of the battery.

2. REMOVE 2 REAR WHEELS

Torque: 131 N·m (1,340 kgf·cm, 97 ft·lbf)

3. DRAIN HYPOID GEAR OIL

Torque: 49 N·m (500 kgf·cm, 36 ft·lbf)

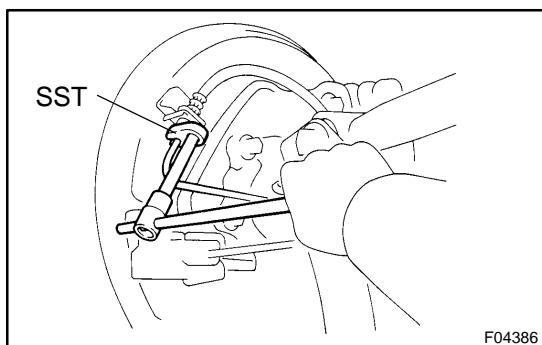

4. DISCONNECT BRAKE LINES

- (a) Using SST, disconnect the brake line and remove the clip.
SST 09023-00100

Torque: 15 N·m (150 kgf·cm, 11 ft·lbf)

- (b) Employ the same manner described above to the other side.

5. DISCONNECT PARKING BRAKE CABLES

- (a) Remove the 2 clips, pin and disconnect the parking brake cable from the bellcrank.

- (b) Employ the same manner described above to the other side.

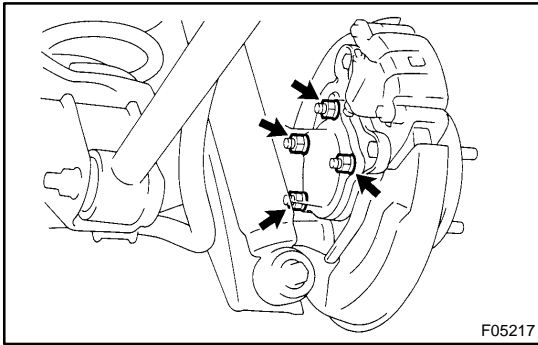
**6. REMOVE AXLE SHAFTS**

- (a) Remove the 4 nuts.
Torque: 123 N·m (1,250 kgf·cm, 90 ft·lbf)
- (b) Pull out the axle shaft assembly and remove the nut.

NOTICE:

Be careful not to damage the oil seal.

- (c) Employ the same manner described above to the other side.

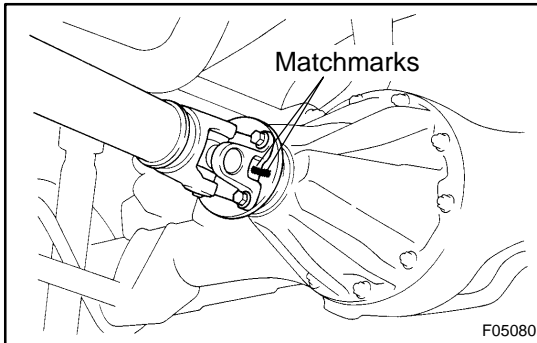
**7. DISCONNECT REAR PROPELLER SHAFT**

- (a) Place matchmarks on the propeller shaft and differential flange.
- (b) Remove the 4 nuts, bolts, washers and disconnect the propeller shaft.

Torque: 106 N·m (1,080 kgf·cm, 78 ft·lbf)

- (c) Support the propeller shaft securely.

8. REMOVE NO. 1 AND NO. 2 ACTUATOR PROTECTORS

- (a) Remove the nut, bolt and No. 1 actuator protector.

Torque: 15 N·m (150 kgf·cm, 11 ft·lbf)

- (b) Remove the 2 nuts and No. 2 actuator protector.

Torque: 36 N·m (367 kgf·cm, 27 ft·lbf)

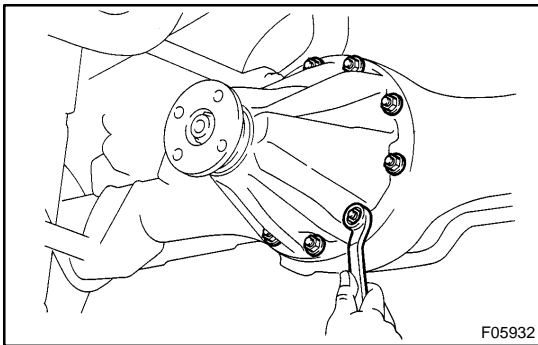
9. DISCONNECT CONNECTORS AND HOSE**10. REMOVE DIFFERENTIAL CARRIER ASSEMBLY**

- (a) Remove the 10 nuts, washers and differential carrier assembly.

NOTICE:

Be careful not to damage the installation surface.

Torque: 72 N·m (740 kgf·cm, 53 ft·lbf)

- (b) Remove the gasket.

HINT:

At the time of installation, please refer to the following items.

- Before installation, connect the connectors of the actuator to the connector on the vehicle side, check the differential lock is in operation.
- Before installation, check that the sleeves are in operation while switching over the differential lock control switch.
- After installation, check that the rear differential lock is in operation.

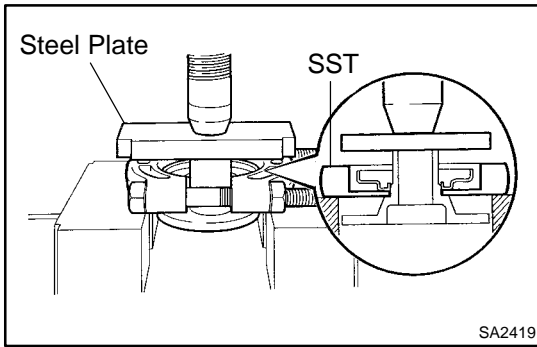

REPLACEMENT

- 1. REMOVE COMPANION FLANGE DUST DEFLECTOR**
Using SST, a steel plate and press, remove the dust deflector.
SST 09950-00020

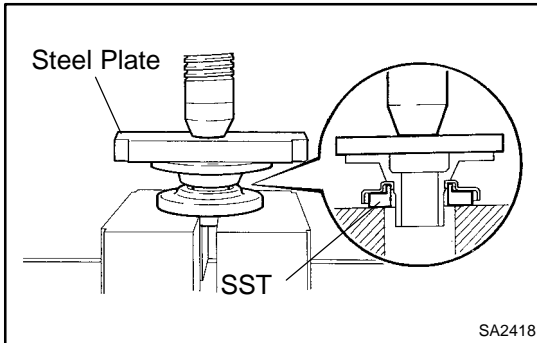

- 2. INSTALL DUST DEFLECTOR**
Using SST, a steel plate and press, install a new dust deflector.
SST 09726-40010

REAR DIFFERENTIAL CARRIER (w/ LSD) COMPONENTS

SA15Y-03

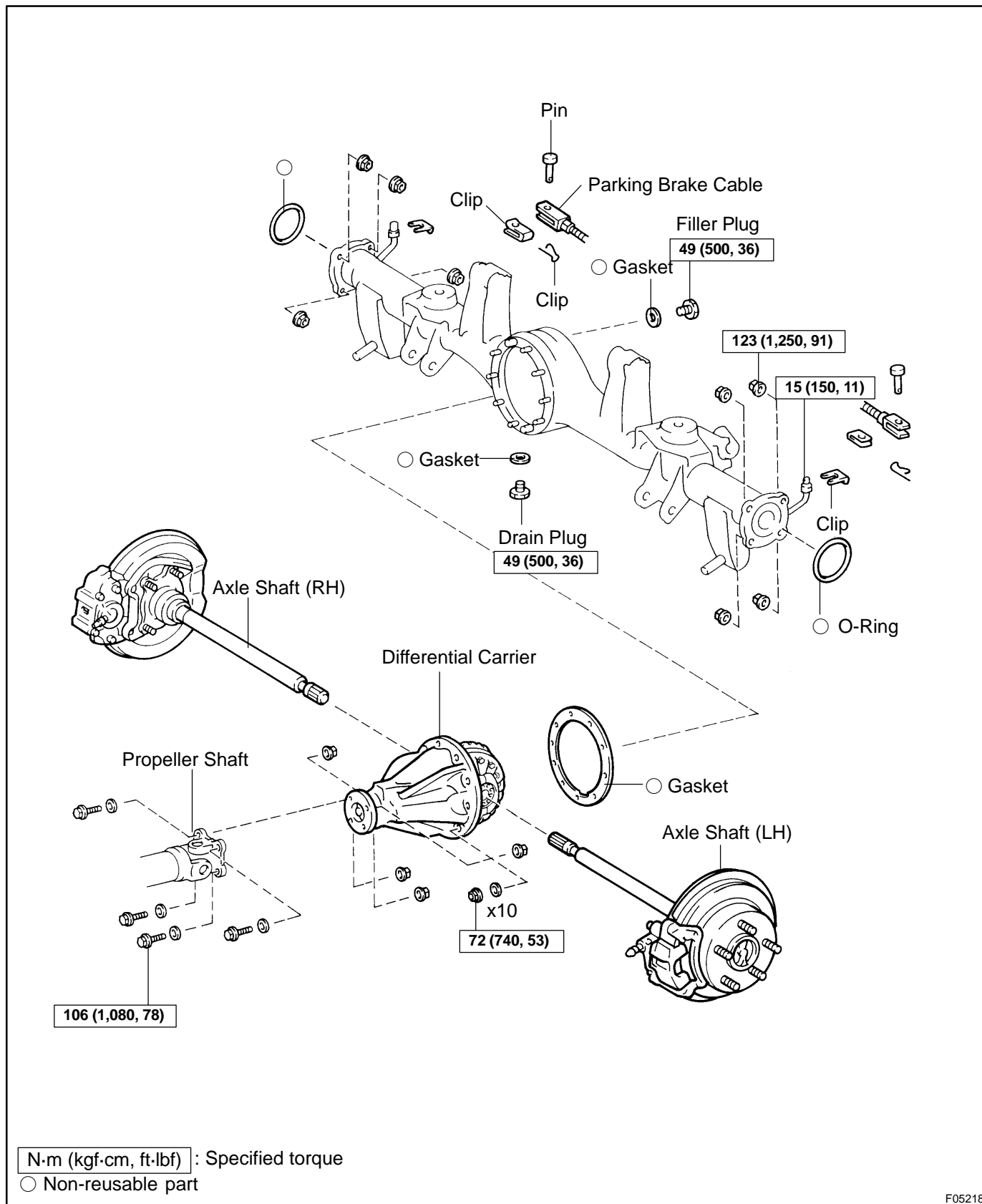

F05218

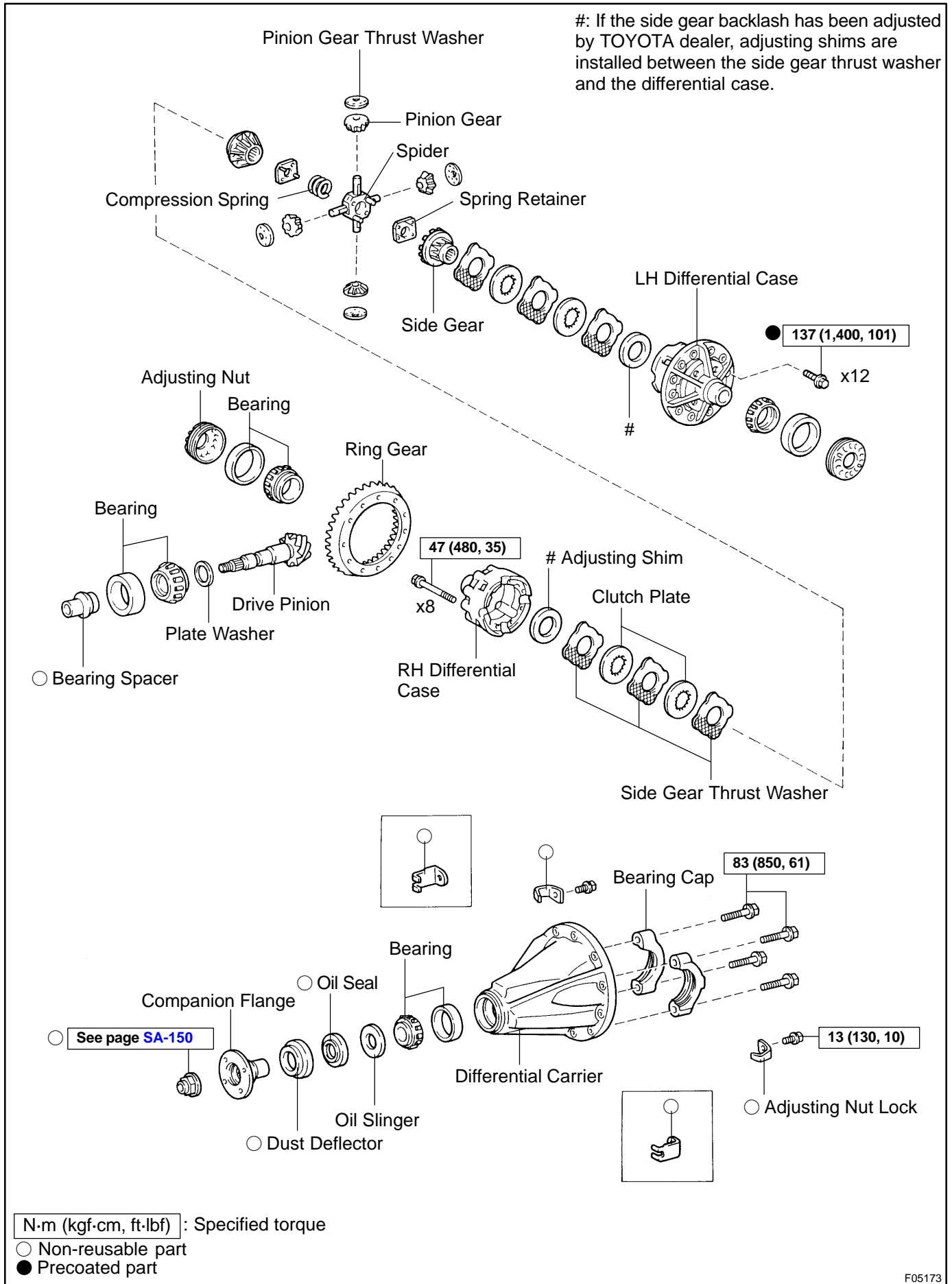

F05173

DISASSEMBLY

1. SET DIFFERENTIAL CARRIER TO OVERHAUL STAND, ETC.

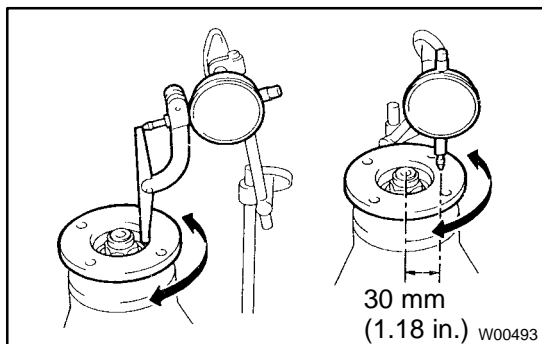

2. CHECK RUNOUT OF COMPANION FLANGE

Using a dial indicator, measure the vertical and lateral runout of the companion flange.

Maximum runout: 0.10 mm (0.0039 in.)

If the runout is greater than the maximum, replace the companion flange.

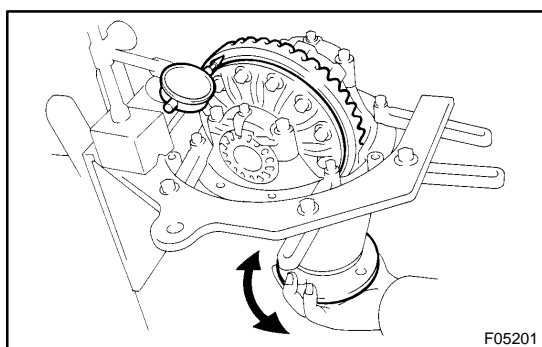

3. CHECK RING GEAR RUNOUT

Using a dial indicator, measure the ring gear runout.

Maximum runout: 0.05 mm (0.0020 in.)

If the runout is greater than the maximum, replace the ring gear.

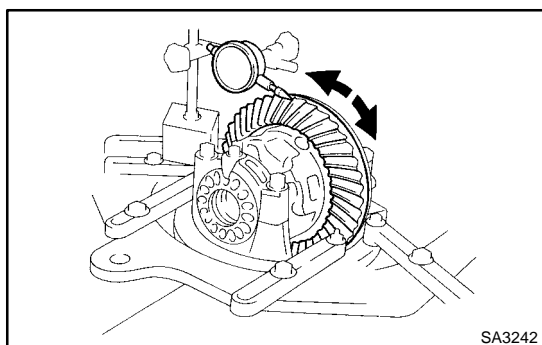

4. CHECK RING GEAR BACKLASH

Using a dial indicator, while holding the drive pinion flange, measure the ring gear backlash.

Backlash: 0.13 - 0.18 mm (0.0051 - 0.0071 in.)

HINT:

Perform the measurements at 3 or more positions around the circumference of the ring gear.

If the backlash is not within the specified value, adjust the side bearing preload or repair as necessary.

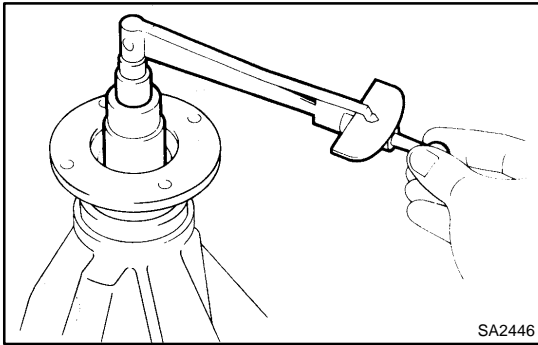

5. MEASURE DRIVE PINION PRELOAD

Using a torque wrench, measure the drive pinion preload using the backlash of the drive pinion and ring gear.

Preload (at starting):

0.64 - 0.92 N·m (6.5 - 9.4 kgf·cm, 5.7 - 8.1 in.-lbf)

6. CHECK TOTAL PRELOAD

Using a torque wrench, measure the total preload with the teeth of the drive pinion and ring gear in contact.

Total preload (at starting):

Drive pinion preload plus

0.38 - 0.63 N·m (3.9 - 6.5 kgf·cm, 3.3 - 5.6 in.-lbf)

If necessary, disassemble and inspect the differential.

7. CHECK TOOTH CONTACT BETWEEN RING GEAR AND DRIVE PINION (See page SA-150)

8. REMOVE COMPANION FLANGE

(a) Using a chisel and hammer, unstake the nut.

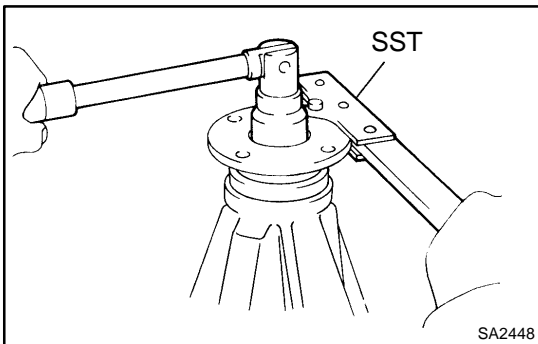

(b) Using SST to hold the flange, remove the nut.
SST 09330-00021

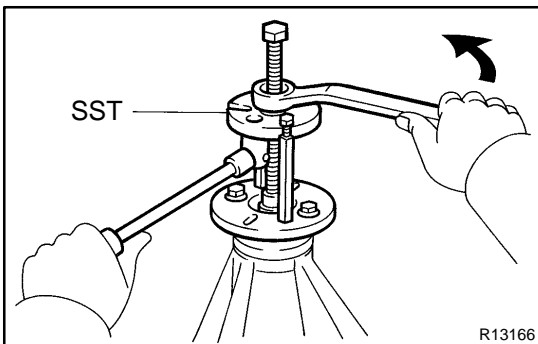

(c) Using SST, remove the companion flange.
SST 09950-30012 (09951-03010, 09953-03010, 09954-03010, 09955-03030, 09956-03040)

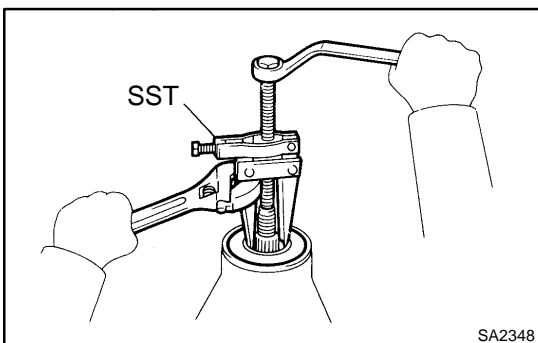

9. REMOVE OIL SEAL AND OIL SLINGER

(a) Using SST, remove the oil seal from the differential carrier.
SST 09308-10010

(b) Remove the oil slinger.

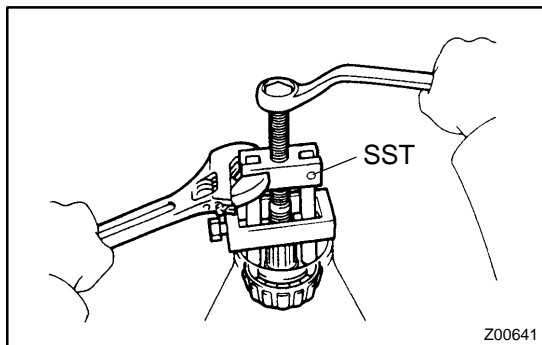
**10. REMOVE FRONT BEARING**

Using SST, remove the front bearing from the drive pinion.

SST 09556-22010

If the front bearing is damaged or worn, replace the bearing.

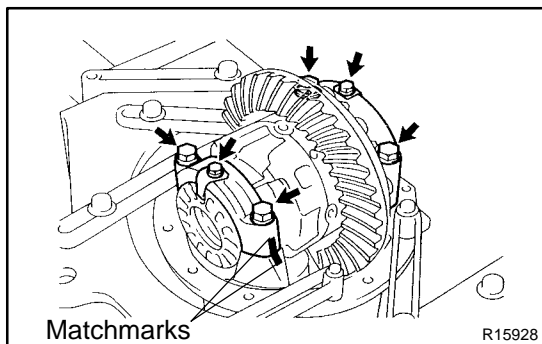
**11. REMOVE DIFFERENTIAL CASE**

(a) Place matchmarks on the bearing cap and differential carrier.

(b) Remove the 2 bolts and adjusting nut locks.

(c) Remove the 4 bolts, 2 bearing caps and adjusting nuts.

HINT:

Tag the disassembled parts to show the location for reassembling.

(d) Remove the differential case with the bearing outer races.

HINT:

Tag the disassembled parts to show the location for reassembling.

12. REMOVE DRIVE PINION AND BEARING SPACER

(a) Remove the drive pinion with the rear bearing.

(b) Remove the bearing spacer.

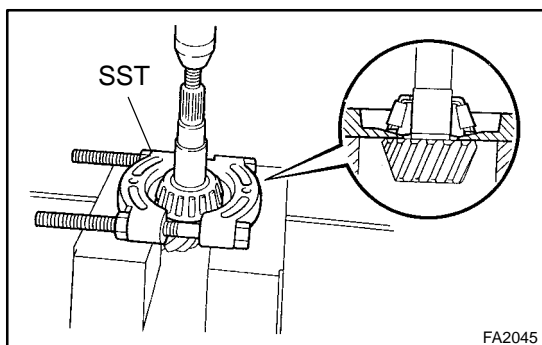
**13. REMOVE DRIVE PINION REAR BEARING**

(a) Using SST and a press, remove the rear bearing from the drive pinion.

SST 09950-00020

HINT:

If the drive pinion or ring gear is damaged, replace them as a set.

(b) Remove the plate washer from the drive pinion.

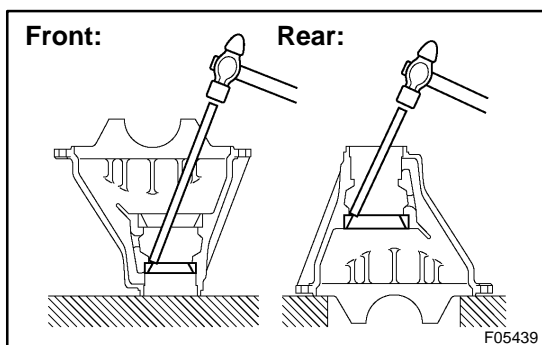
**14. REMOVE FRONT AND REAR BEARING OUTER RACES**

Using a brass bar and hammer, remove the outer races.

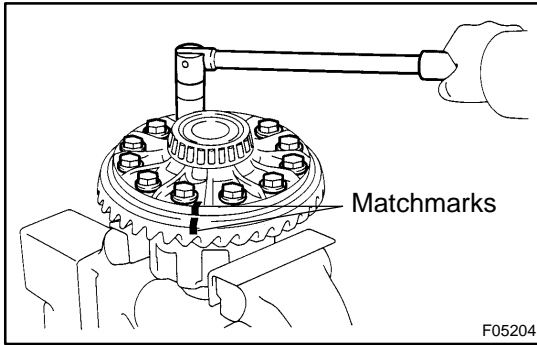
**15. REMOVE RING GEAR**

- (a) Place matchmarks on the ring gear and differential case.
- (b) Remove the 12 ring gear set bolts.
- (c) Using a plastic hammer, tap on the ring gear to remove it from the differential case.

16. CHECK DIFFERENTIAL CASE RUNOUT

- (a) Place the bearing outer races on their respective bearings. Check that the right and left outer races are not interchanged.
- (b) Install the differential case in the differential carrier.
- (c) Tighten the adjusting nut just to where there is no play in the bearing.
- (d) Align the matchmarks on the bearing cap and differential carrier.
- (e) Install and uniformly tighten the bearing cap bolts a little at a time.

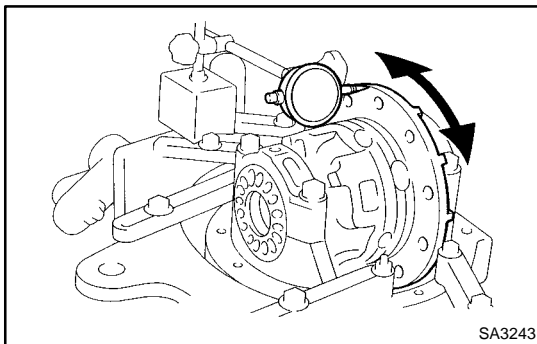

- (f) Using a dial indicator, measure the differential case runout.

Maximum runout: 0.04 mm (0.0016 in.)

- (g) Remove the differential case.

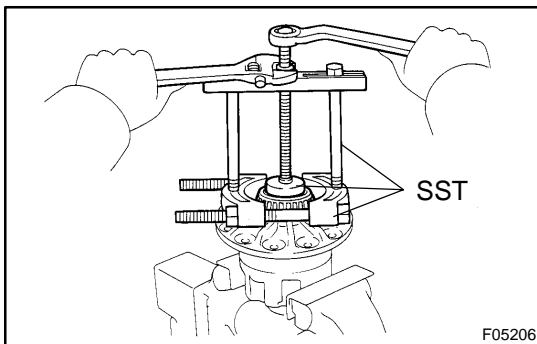
**17. REMOVE SIDE BEARINGS FROM DIFFERENTIAL CASE**

Using SST, remove the 2 side bearings from the differential case.

SST 09950-00020, 09950-00030,
09950-4001 1 (09957-04010),
09950-60010 (09951-00480)

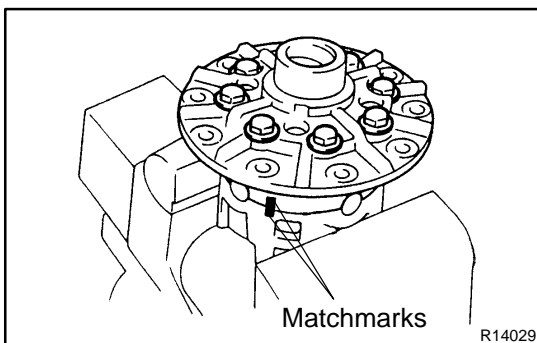
**18. DISASSEMBLE DIFFERENTIAL CASE**

- (a) Place matchmarks on the RH and LH cases.
- (b) Remove the 8 bolts uniformly, a little at a time.
- (c) Using a plastic hammer, separate the RH and LH cases.

- (d) Remove the 2 side gears, 6 side gear thrust washers, 4 clutch plates, 2 spring retainers, compression spring, 4 pinion gears, 4 pinion gear thrust washers and spider from the differential case.

HINT:

- Keep the disassembled parts in order.
- If the side gear backlash has been adjusted by TOYOTA dealer, adjusting shims are installed between the side gear thrust washer and the differential case.

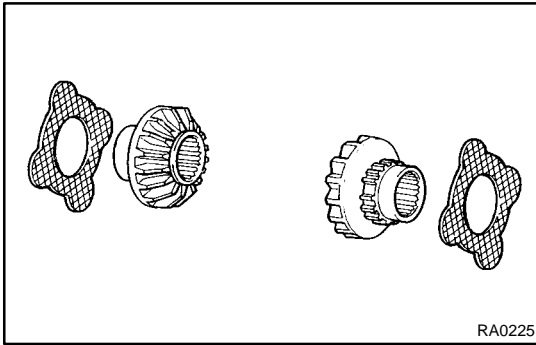

INSPECTION

- 1. REPLACE PARTS THAT ARE DAMAGED OR WORN**
HINT:
 If replacing the side gear, also replace the thrust washer that contact with it.

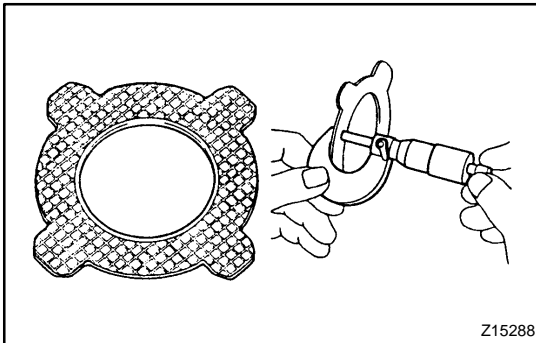

- 2. INSPECT SIDE GEAR THRUST WASHERS FOR WEAR OR DAMAGE**

Using a micrometer, measure that the contact surface of the thrust washer is even and check that no bare metal is showing.

Thickness (Reference):

1.97 - 2.06 mm (0.0776 - 0.0811 in.)

If necessary, replace the thrust washer.

HINT:

If replacing the thrust washer, also replace the clutch plate that contacts with it.

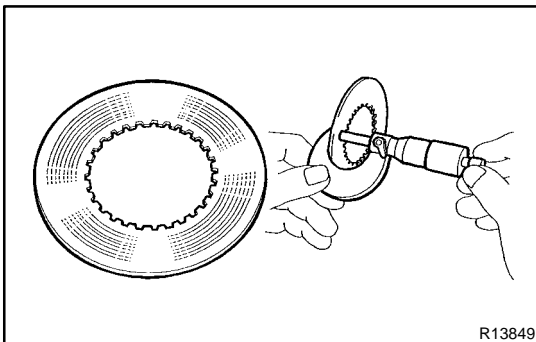

- 3. INSPECT CLUTCH PLATE FOR WEAR OR DAMAGE**

Using a micrometer, measure the contact surface of the clutch plate and check that there is no abnormal wear.

Thickness (Reference):

1.97 - 2.03 mm (0.0776 - 0.0799 in.)

If necessary, replace the clutch plate.

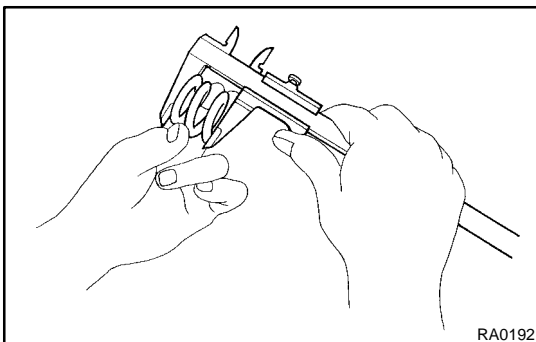

- 4. INSPECT COMPRESSION SPRING FREE LENGTH**
 Using vernier calipers, measure the free length of the spring.
Length (Reference): 32.8 mm (1.291 in.)

INSTALLATION

Installation is in the reverse order of removal (See page [SA-141](#)).

HINT:

After installation, fill the differential with hypoid gear oil for LSD (See page [SA-95](#)), fill the brake reservoir with brake fluid, bleed the brake system (See page [BR-4](#)), check for leaks and check the ABS speed sensor signal (See page [DI-505](#)).

REASSEMBLY

HINT:

- When reusing the side gear, thrust washers and clutch plates, skip the STEP 1.
- Using a shop rag, clean off any foreign object from the parts.
- Apply all of the sliding and rotating surfaces with LSD oil.

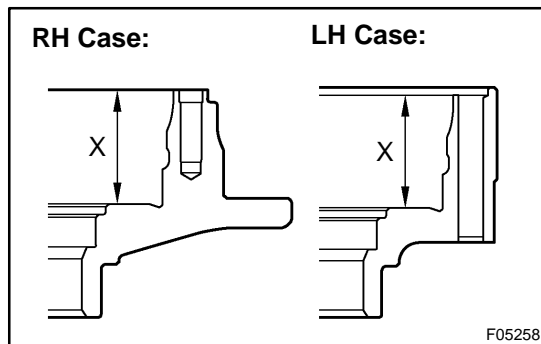

1. SELECT ADJUSTING SHIM

- (a) Measure the RH and LH differential case dimensions "X", as shown in the illustration.

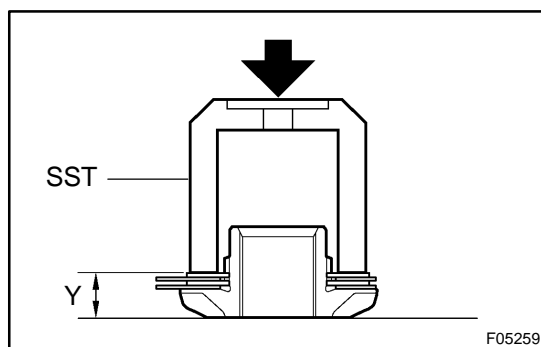

- (b) Install the thrust washers and clutch plates on the side gear.
- (c) Using SST to press down the thrust washers and clutch plates with about pressure of 10 kgf (22 lbf), measure dimension "Y", as shown in the illustration.
SST 09649-17010
- (d) Referring to the following selection table on the next page, select the proper adjusting shim.

**Adjust shim thickness =
X - Y - 19.08 mm (0.7511 in.)**

SUSPENSION AND AXLE - REAR DIFFERENTIAL CARRIER (w/ LSD)

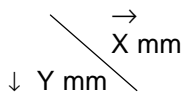

	46.05	46.06	46.07	46.08	46.09	46.10	46.11	46.12	46.13	46.14	46.15	46.16	46.17	46.18	46.19	46.20	46.21	46.22
26.45																		
26.46																		
26.47																		C + D
26.48																		
26.49																		
26.50																		
26.51																		C + C
26.52																		
26.53																		
26.54																		
26.55																		
26.56																		
26.57																		
26.58																		
26.59																		
26.60																		
26.61																		
26.62																		
26.63																		
26.64																		
26.65																		
26.66																		
26.67																		
26.68																		
26.69																		
26.70																		
26.71																		
26.72																		
26.73																		
26.74																		
26.75																		
26.76																		
26.77																		
26.78																		
26.79																		
26.80																		
26.81																		
26.82																		
26.83																		
26.84																		
26.85																		
26.86																		
26.87																		
26.88																		

#: Reassemble another type shim or check the backlash after assembling A shim.

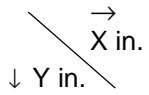

	1.8129	1.8133	1.8137	1.8141	1.8145	1.8149	1.8153	1.8157	1.8161	1.8165	1.8169	1.8173	1.8177	1.8181	1.8185	1.8188	1.8192	1.8196	
1.0413																			
1.0417																			
1.0421																			
1.0425																			
1.0429																			
1.0433																			
1.0436																			
1.0440																			
1.0444																			
1.0448																			
1.0452																			
1.0456																			
1.0460																			
1.0464																			
1.0468																			
1.0472																			
1.0476																			
1.0480																			
1.0484																			
1.0488																			
1.0492																			
1.0496																			
1.0499																			
1.0503																			
1.0507																			
1.0511																			
1.0515																			
1.0519																			
1.0523																			
1.0527																			
1.0531																			
1.0535																			
1.0539																			
1.0543																			
1.0547																			
1.0551																			
1.0555																			
1.0559																			
1.0562																			
1.0566																			
1.0570																			
1.0574																			
1.0578																			
1.0582																			

#: Reassemble another type shim or check the backlash after assembling A shim.

Adjust shim thickness:

Mark	Thickness	mm (in.)	Mark	Thickness	mm (in.)
A	0.20	(0.0079)	C	0.30	(0.0118)
B	0.25	(0.0098)	D	0.35	(0.0138)

2. CHECK SIDE GEAR BACKLASH

- (a) Install the thrust washers, clutch plates and adjusting shim to side gear.

HINT:

Install the adjusting shim with its surface having no oil groove facing to the differential case side.

- (b) Install the side gear to the differential case.
 (c) Install the 4 pinion gears and thrust washers to the spider.

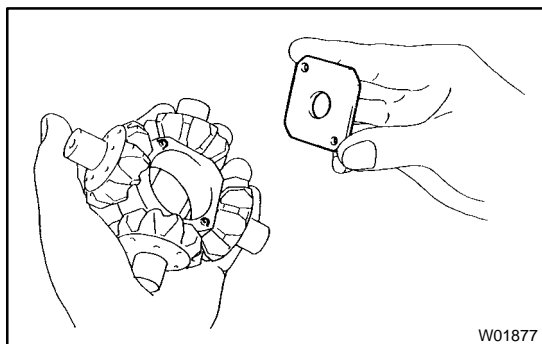

- (d) Align the spring retainer holes with the straight pins and install the retainer.

- (e) Install the spider to the differential case.

HINT:

Install the spider to the differential case tightly and do not move the spring retainer.

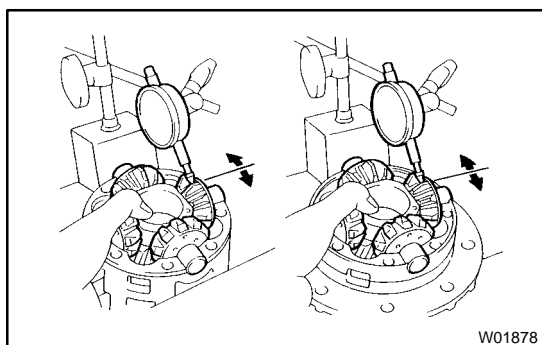

- (f) Using a dial indicator, measure the side gear backlash while holding the side gear and spider.

Backlash: 0.02 - 0.15 mm (0.0008 - 0.0059 in.)

HINT:

- Measure at all 4 locations.
- Measure the backlash at the RH and LH differential cases.

If the backlash is not within the specified value, select the adjusting shim.

3. ASSEMBLE DIFFERENTIAL CASE

- (a) Reinstall the spider to the LH differential case.

HINT:

Install the spider to the LH differential case tightly and do not move the spring retainer.

- (b) Install the compression spring and RH spring retainer.
 (c) Install the RH side gear.
 (d) Align the matchmarks and assemble the RH and LH differential cases.

HINT:

- Be careful not to drop the side gear.
- Check the pinion and side gear alignment.
- (e) Tighten the 8 bolts uniformly, a little at a time.

Torque: 47 N·m (480 kgf-cm, 35 ft-lbf)

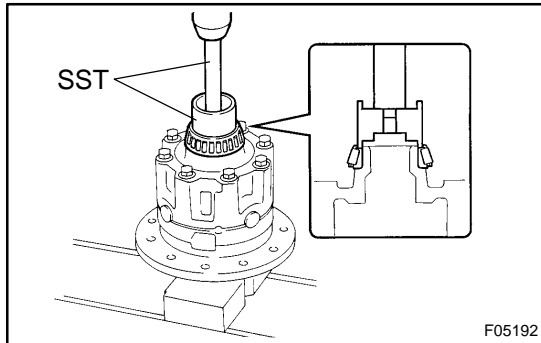
**4. INSTALL SIDE BEARING**

- (a) Using SST and a press, install the RH side bearing on the differential case.

SST 09710-30050, 09950-70010 (09951-07100)

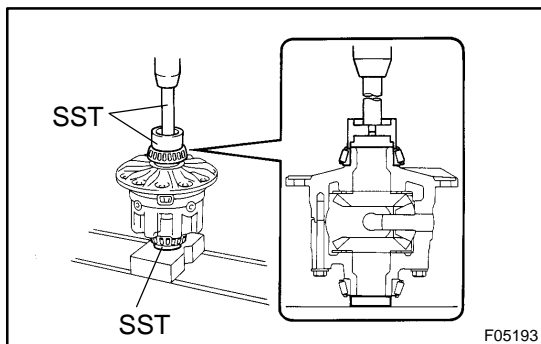

- (b) Using SST and a press, install the LH side bearing on the differential case.

SST 09710-30050, 09950-60010 (09951-00480),
09950-70010 (09951-07100)

5. INSTALL RING GEAR ON DIFFERENTIAL CASE

- (a) Clean the threads of the bolts and differential case with the white gasoline.

- (b) Clean the contact surfaces of the differential case and ring gear.

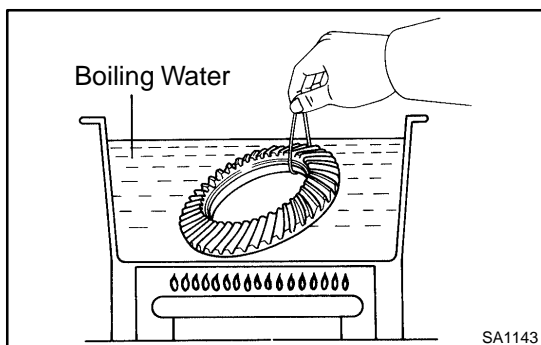

- (c) Heat the ring gear to about 100 °C (212 °F) in boiling water.

- (d) Carefully take the ring gear out of the boiling water.

- (e) After the moisture on the ring gear has completely evaporated, quickly install the ring gear to the differential case.

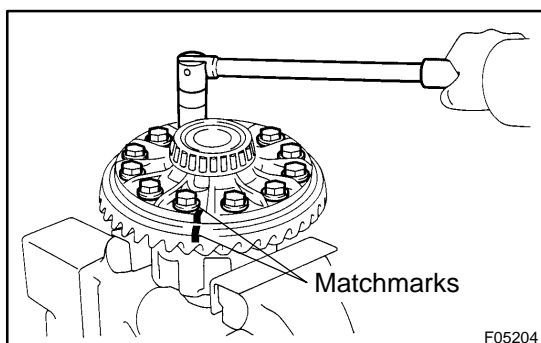

- (f) Align the matchmarks on the ring gear and differential case.

- (g) Temporarily install the 12 set bolts.

- (h) After the ring gear has cooled down enough, torque the 12 set bolts to which thread lock has been applied.

Thread lock:

**Part No. 08833-00100, THREE BOND 1360K
or equivalent**

Torque: 137 N·m (1,400 kgf-cm, 101 ft-lbf)

6. CHECK RING GEAR RUNOUT

- (a) Place the bearing outer races on their respective bearings. Check that the right and left outer races are not interchanged.
- (b) Install the differential case onto the carrier and tighten the adjusting nut just to where there is no play in the bearings.

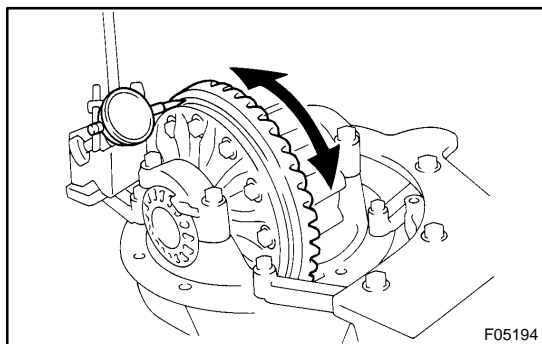

- (c) Using a dial indicator, measure the ring gear runout.
Maximum runout: 0.05 mm (0.0020 in.)
- (d) Remove the differential case.

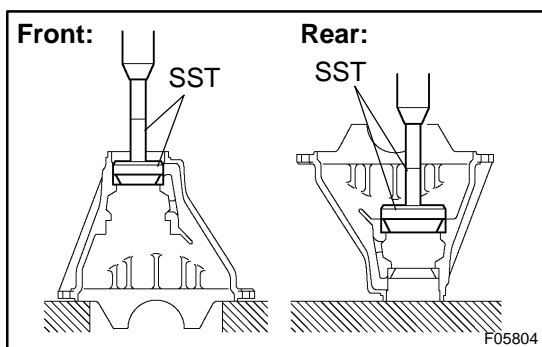
**7. INSTALL DRIVE PINION FRONT AND REAR BEARING OUTER RACES**

- (a) Using SST and a press, install the front bearing outer race.
SST 09950-60020 (09951-00710),
09950-70010 (09951-07150)
- (b) Using SST and a press, install the rear bearing outer race.
SST 09950-60020 (09951-00890),
09950-70010 (09951-07150)

8. INSTALL DRIVE PINION REAR BEARING

- (a) Install the plate washer on the drive pinion.

HINT:

First fit a washer with the same thickness as the washer which was removed, then after checking the tooth contact pattern, replace the washer with one of a different thickness if necessary.

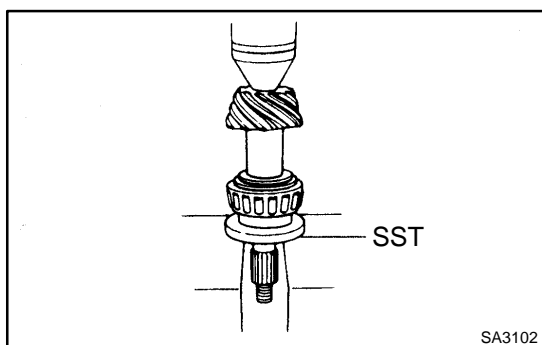

- (b) Using SST and a press, install the rear bearing onto the drive pinion.
SST 09506-35010

9. TEMPORARILY ADJUST DRIVE PINION PRELOAD

- (a) Install the drive pinion and front bearing.

HINT:

Assemble the spacer and oil seal after adjusting the gear contact pattern.

- (b) Install the oil slinger.

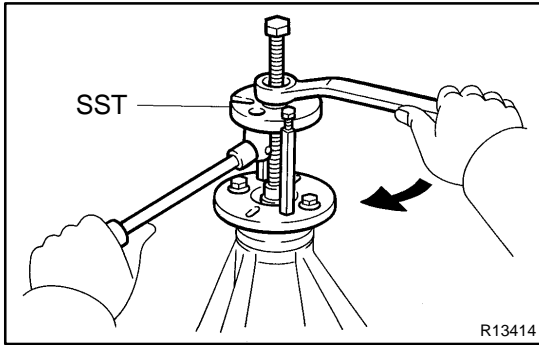

- (c) Install the companion flange with SST.
SST 09950-30012 (09951-03010, 09953-03010, 09954-03010, 09955-03030, 09956-03040)

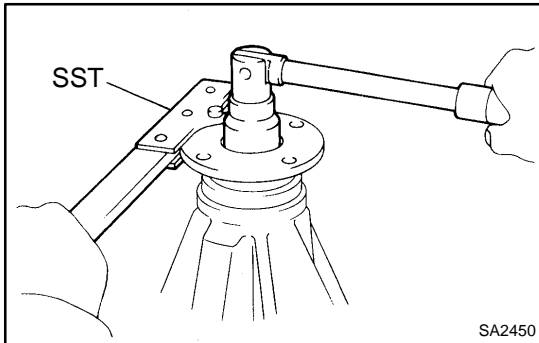

- (d) Using SST to hold the flange and adjust the drive pinion preload by tightening the companion flange nut.
SST 09330-00021

NOTICE:

- Coat the nut and screw of the drive pinion with gear oil.
- As there is no spacer, tighten the nut a little at a time, being careful not to overtighten.

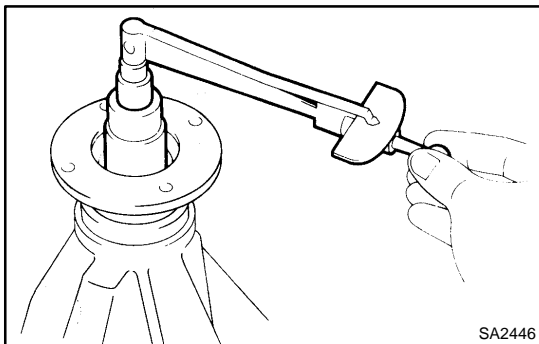

- (e) Using a torque wrench, measure the preload.

Preload (at starting):**New bearing**

1.3 - 1.8 N·m (13 - 19 kgf·cm, 11.5 - 15.9 in.-lbf)

Reused bearing

0.64 - 0.92 N·m (6.5 - 9.4 kgf·cm, 5.7 - 8.1 in.-lbf)

HINT:

Measure the total preload after turning the bearing clockwise and counterclockwise several times to make the bearing smooth.

10. INSTALL DIFFERENTIAL CASE IN CARRIER

- (a) Place the 2 bearing outer races on their respective bearings. Make sure that the right and left outer races are not interchanged.

- (b) Install the differential case in the carrier.

HINT:

Make sure that there is backlash between the ring gear and drive pinion.

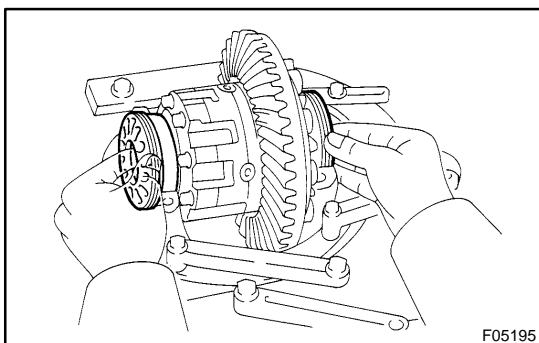
**11. INSTALL ADJUSTING NUTS**

Install the 2 adjusting nuts on the carrier, making sure the nuts are engaged properly.

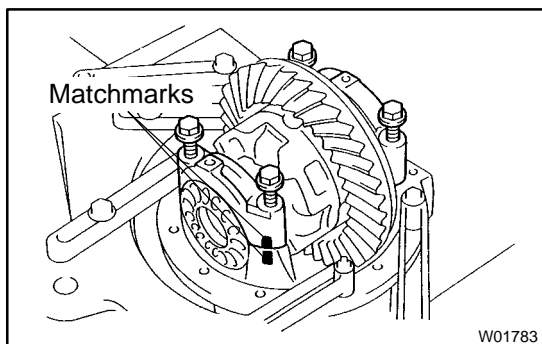

12. INSTALL BEARING CAPS

Align the matchmarks on the bearing cap and carrier. Screw in the 2 bearing cap bolts 2 or 3 turns and press down the bearing cap by hand.

HINT:

If the bearing cap does not fit tightly on the carrier, the adjusting nuts are not engaged properly. Reinstall the adjusting nuts if necessary.

13. ADJUST SIDE BEARING PRELOAD

- (a) Torque the 4 bolts.

Torque: 83 N·m (850 kgf·cm, 61 ft·lbf)

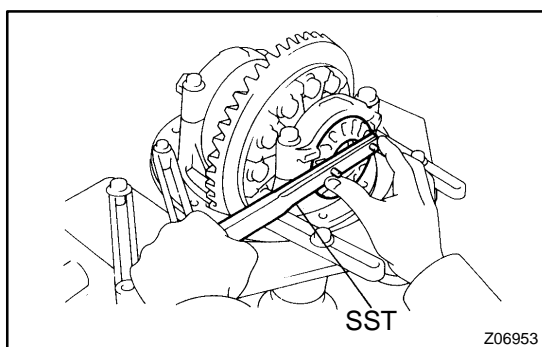

- (b) Then loosen them to the point where the adjusting nuts can be turned by SST.

SST 09504-0001 1

- (c) Tighten the 4 bolts.

Torque: 9.8 N·m (100 kgf·cm, 7 ft·lbf)

- (d) Using SST, torque the adjusting nut on the ring gear side until the ring gear has a backlash of about 0.2 mm (0.008 in.).

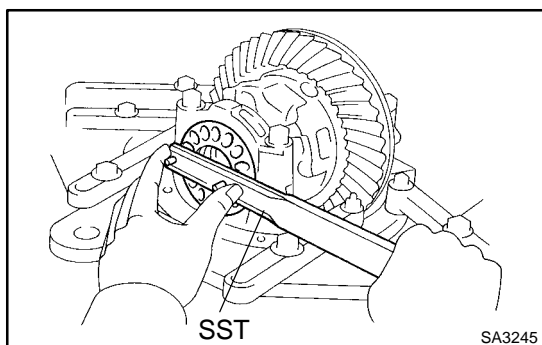

- (e) While turning the ring gear, use the SST to fully tighten the adjusting nut on the drive pinion side. After the bearings are settled, loosen the adjusting nut on the drive pinion side.

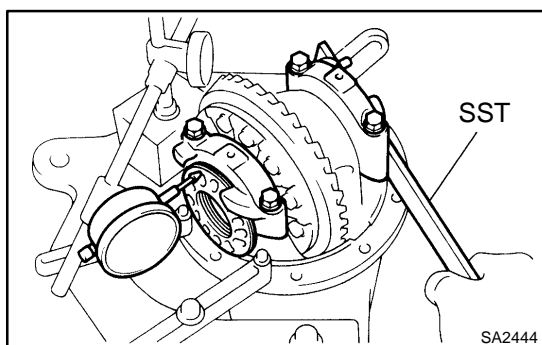

- (f) Place a dial indicator on the top of the adjusting nut on the ring gear side.
- (g) Adjust the side bearing to zero preload by tightening the other adjusting nut until the pointer on the indicator begins to move.

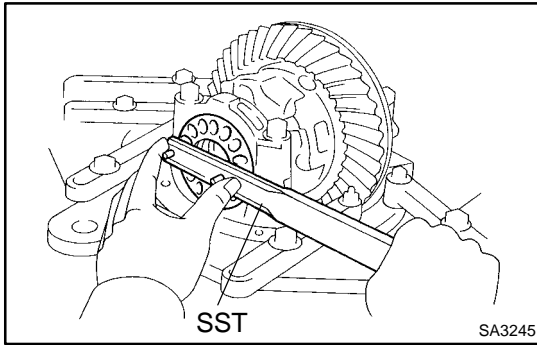

- (h) Using the SST, torque the adjusting nut 1 - 1.5 notches from the zero preload position.

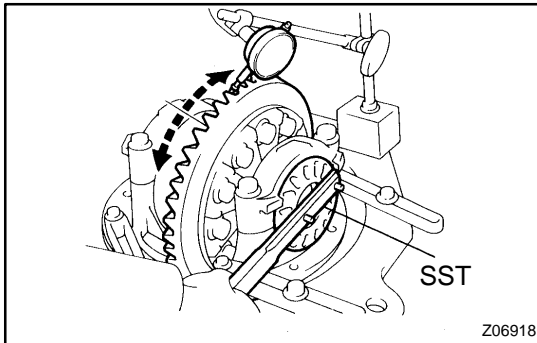

- (i) Using a dial indicator, adjust the ring gear backlash until it is within the specified value.

Backlash: 0.13 - 0.18 mm (0.0051 - 0.0071 in.)

HINT:

The backlash is adjusted by turning the right and left adjusting nuts equal amounts. For example, loosen the nut on the left side 1 notch and torque the nut on the right side 1 notch.

- (j) Torque the 4 bolts.
Torque: 83 N·m (850 kgf·cm, 61 ft·lbf)
- (k) After rotating the ring gear 5 turns or more, recheck the ring gear backlash.

Backlash: 0.13 - 0.18 mm (0.0051 - 0.0071 in.)

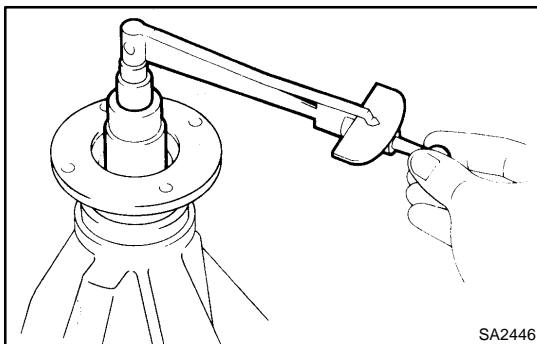

14. MEASURE TOTAL PRELOAD

Using a torque wrench, measure the preload with the teeth of the drive pinion and ring gear in contact.

Preload (at starting):

Drive pinion preload plus

0.38 - 0.63 N·m (3.9 - 6.5 kgf·cm, 3.3 - 5.6 in.-lbf)

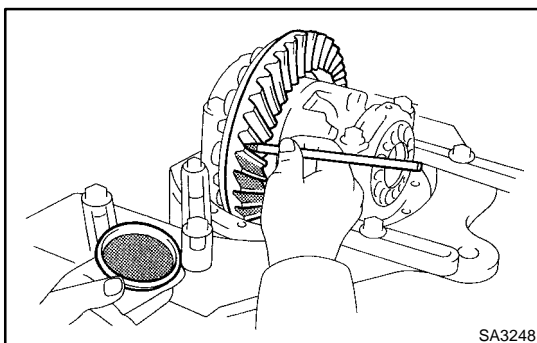

15. INSPECT TOOTH CONTACT BETWEEN RING GEAR AND DRIVE PINION

- (a) Coat 3 or 4 teeth at 3 different positions on the ring gear with red lead primer.
- (b) Turn the companion flange, in both directions to inspect the ring gear for proper tooth contact.

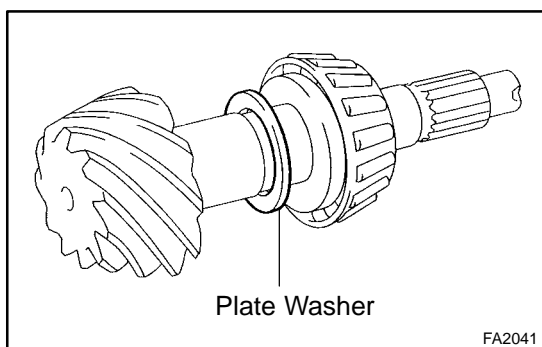
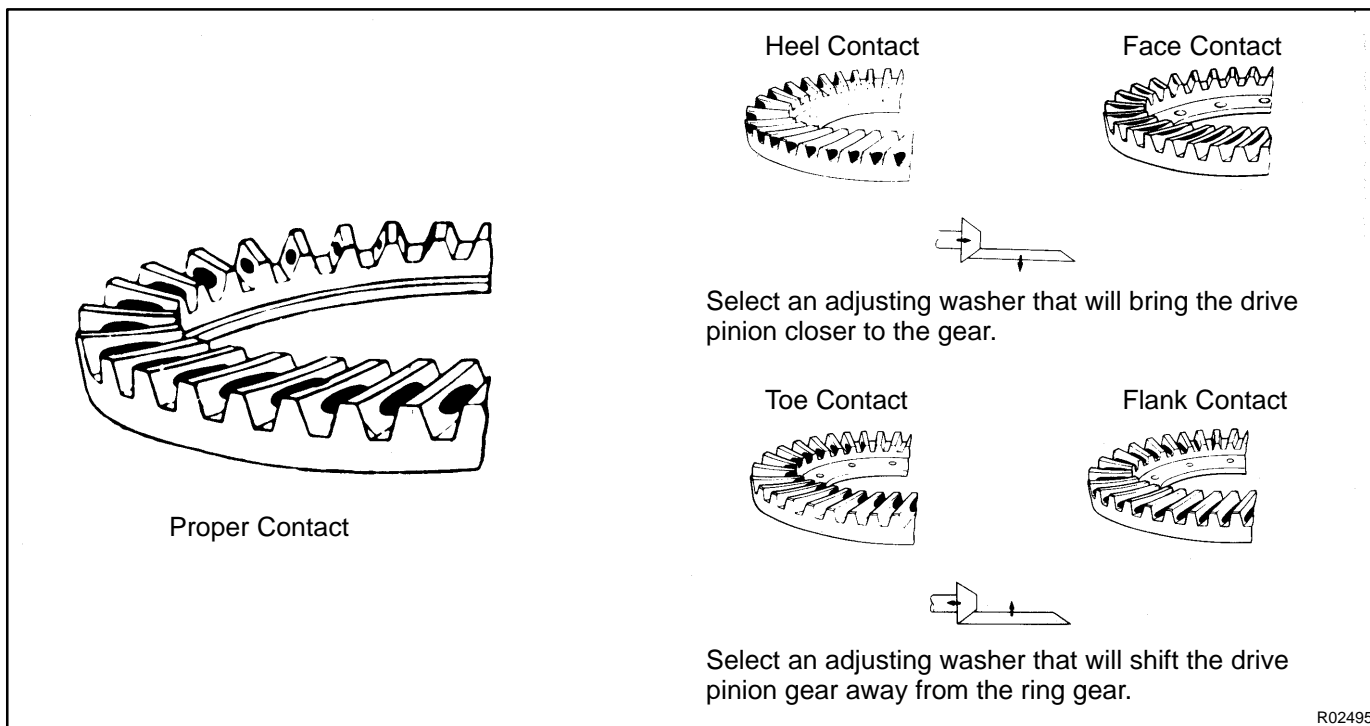

If the teeth are not contacting properly, use the following table to select a proper washer for correction.

Plate washer thickness:

Thickness mm (in.)	Thickness mm (in.)
1.050 (0.04134)	1.325 (0.05217)
1.075 (0.04232)	1.350 (0.05315)
1.100 (0.04331)	1.375 (0.05413)
1.125 (0.04429)	1.400 (0.05512)
1.150 (0.04528)	1.425 (0.05610)
1.175 (0.04626)	1.450 (0.05709)
1.200 (0.04724)	1.475 (0.05807)
1.225 (0.04823)	1.500 (0.05906)
1.250 (0.04921)	1.525 (0.06004)
1.275 (0.05020)	1.550 (0.06102)
1.300 (0.05118)	-

- 16. REMOVE COMPANION FLANGE (See page SA-143)
- 17. REMOVE OIL SLINGER AND FRONT BEARING (See page SA-143)

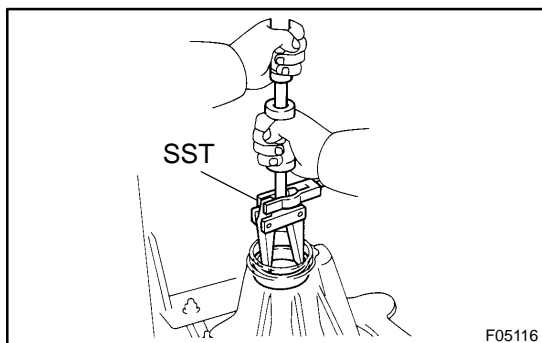

- 18. REMOVE BEARING OUTER RACE
Using SST, remove the bearing outer race.
SST 09308-00010
- 19. INSTALL NEW BEARING SPACER

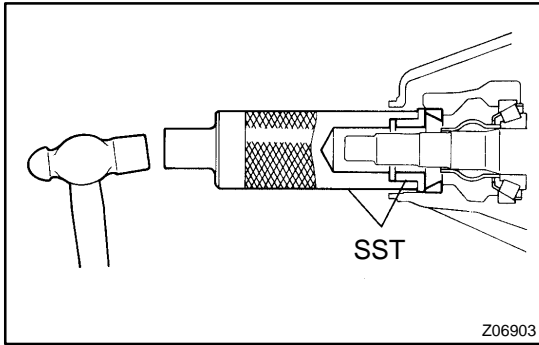
**20. INSTALL BEARING OUTER RACE**

Using SST and a hammer, install the bearing outer race.
SST 09316-6001 1 (09316-00011, 09316-00021)

21. INSTALL FRONT BEARING AND OIL SLINGER**22. INSTALL OIL SEAL**

(a) Coat the hypoid gear oil to a new oil seal periphery.

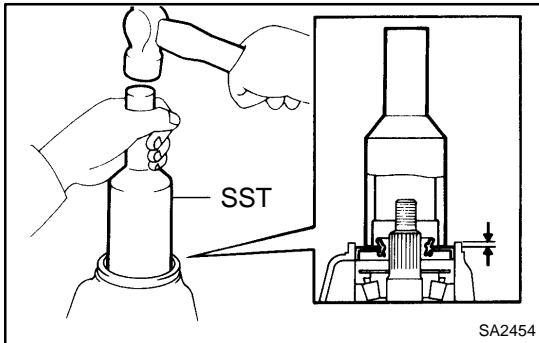

(b) Using SST and a hammer, install the oil seal, as shown.
SST 09214-7601 1

Oil seal driven in depth: 0.5 mm (0.020 in.)

(c) Coat MP grease to the oil seal lip.

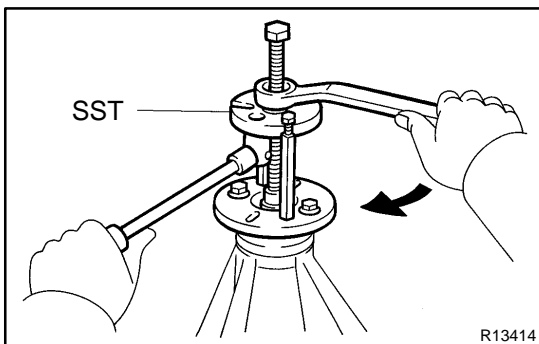
**23. INSTALL COMPANION FLANGE**

(a) Using SST, install the companion flange.

SST 09950-30012 (09951-03010, 09953-03010,
09954-03010, 09955-03030, 09956-03040)

(b) Coat the threads of a new nut with gear oil.

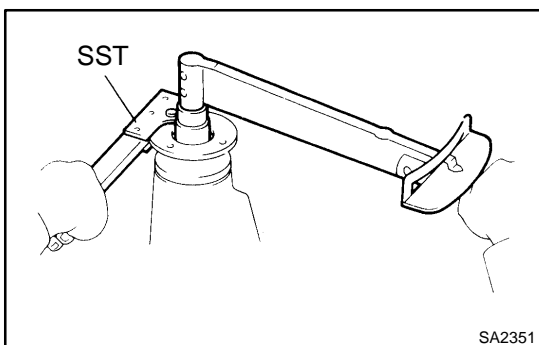

(c) Using SST to hold the flange, install the nut.

SST 09330-00021

Torque: 245 N·m (2,500 kgf·cm, 181 ft·lbf)

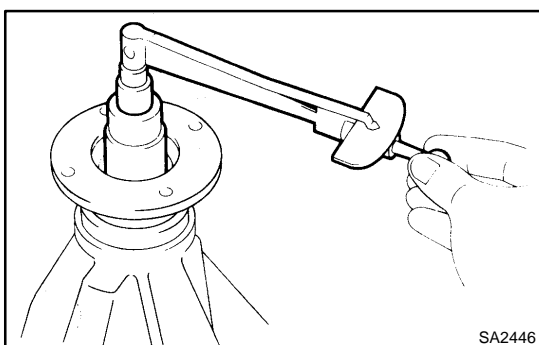
**24. ADJUST DRIVE PINION PRELOAD**

Using a torque wrench, measure the preload of the backlash between the drive pinion and ring gear.

Preload (at starting):

New bearing

1.3 - 1.8 N·m (13 - 19 kgf·cm, 11.5 - 15.9 in.-lbf)

Reused bearing

0.64 - 0.92 N·m (6.5 - 9.4 kgf·cm, 5.7 - 8.1 in.-lbf)

If the preload is greater than the specified value, replace the bearing spacer.

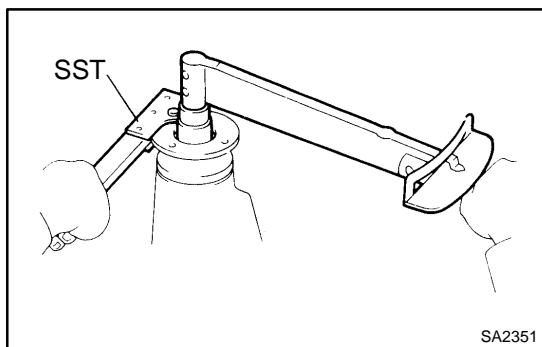

If the preload is less than the specified value, retighten the nut with a force of 13 N·m (130 kgf·cm, 9 ft·lbf) at a time until the specified preload is reached.

SST 09330-00021

Torque: 441 N·m (4,500 kgf·cm, 326 ft·lbf) or less

If the maximum torque is exceeded while retightening the nut, replace the bearing spacer and repeat the preload procedure. Do not loosen the pinion nut to reduce the preload.

25. RECHECK RING GEAR BACKLASH

(See page SA-143)

26. RECHECK TOOTH CONTACT BETWEEN RING GEAR AND DRIVE PINION (See step 15)

27. CHECK RUNOUT OF COMPANION FLANGE (See page SA-143)

28. STAKE DRIVE PINION NUT

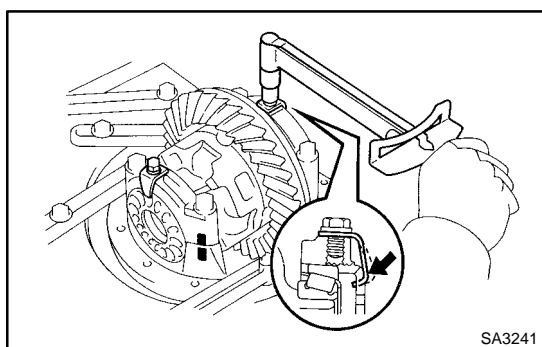

29. INSTALL ADJUSTING NUT LOCKS

- (a) Install 2 new nut locks on the bearing caps.
- (b) After tightening 2 bolts, bend the nut locks.

Torque: 13 N·m (130 kgf·cm, 10 ft·lbf)

30. REMOVE DIFFERENTIAL CARRIER FROM OVERHAUL STAND ETC.

REMOVAL

1. **REMOVE 2 REAR WHEELS**
Torque: 131 N·m (1,340 kgf·cm, 97 ft·lbf)
2. **DRAIN HYPOID GEAR OIL**
Torque: 49 N·m (500 kgf·cm, 36 ft·lbf)

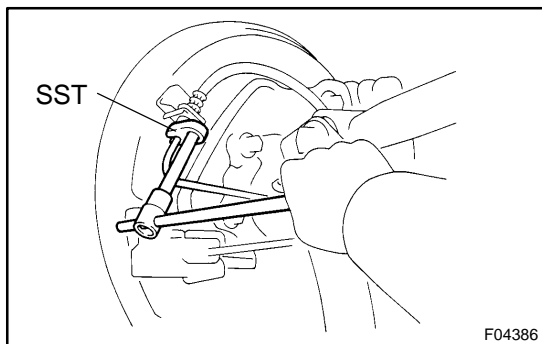

3. **DISCONNECT BRAKE LINES**
 - (a) Using SST, disconnect the brake line and remove the clip.
SST 09023-00100
Torque: 15 N·m (150 kgf·cm, 11 ft·lbf)
 - (b) Employ the same manner described above to the other side.
4. **DISCONNECT PARKING BRAKE CABLES**
 - (a) Remove the 2 clips, pin and disconnect the parking brake cable from the bellcrank.
 - (b) Employ the same manner described above to the other side.

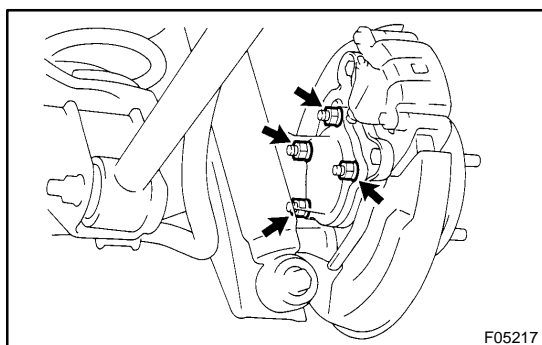

5. **REMOVE AXLE SHAFTS**
 - (a) Remove the 4 nuts.
Torque: 123 N·m (1,250 kgf·cm, 90 ft·lbf)
 - (b) Pull out the axle shaft assembly and remove the O-ring.

NOTICE:
Be careful not to damage the oil seal.

 - (c) Employ the same manner described above to the other side.

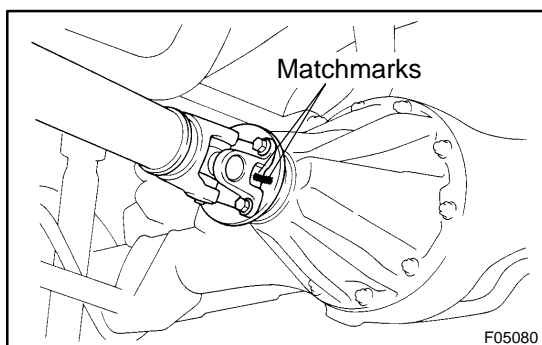

6. **DISCONNECT REAR PROPELLER SHAFT**
 - (a) Place matchmarks on the propeller shaft and differential flange.
 - (b) Remove the 4 nuts, bolts, washers and disconnect the propeller shaft.
Torque: 106 N·m (1,080 kgf·cm, 78 ft·lbf)
 - (c) Support the propeller shaft securely.

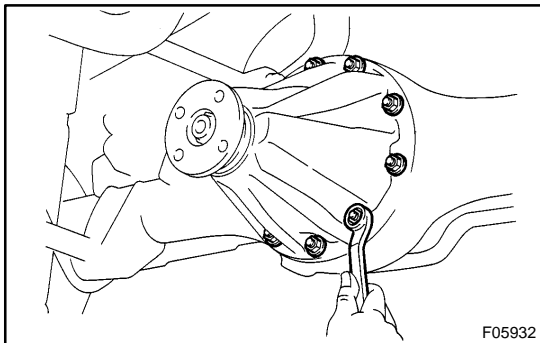
**7. REMOVE DIFFERENTIAL CARRIER ASSEMBLY**

- (a) Remove the 10 nuts, washers and differential carrier assembly.

NOTICE:

Be careful not to damage the installation surface.

Torque: 72 N·m (740 kgf·cm, 53 ft·lbf)

- (b) Remove the gasket.

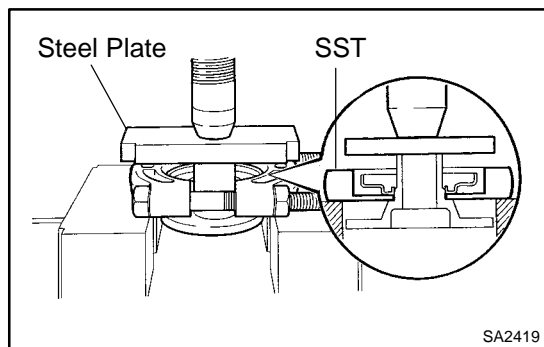

REPLACEMENT

- 1. REMOVE COMPANION FLANGE DUST DEFLECTOR**
Using SST, a steel plate and press, remove the dust deflector.
SST 09950-00020

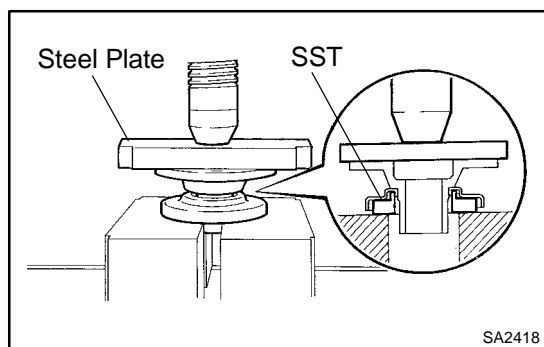

- 2. INSTALL DUST DEFLECTOR**
Using SST, a steel plate and press, install a new dust deflector.
SST 09726-40010

REAR DIFFERENTIAL FRONT OIL SEAL COMPONENTS

SA15K-04

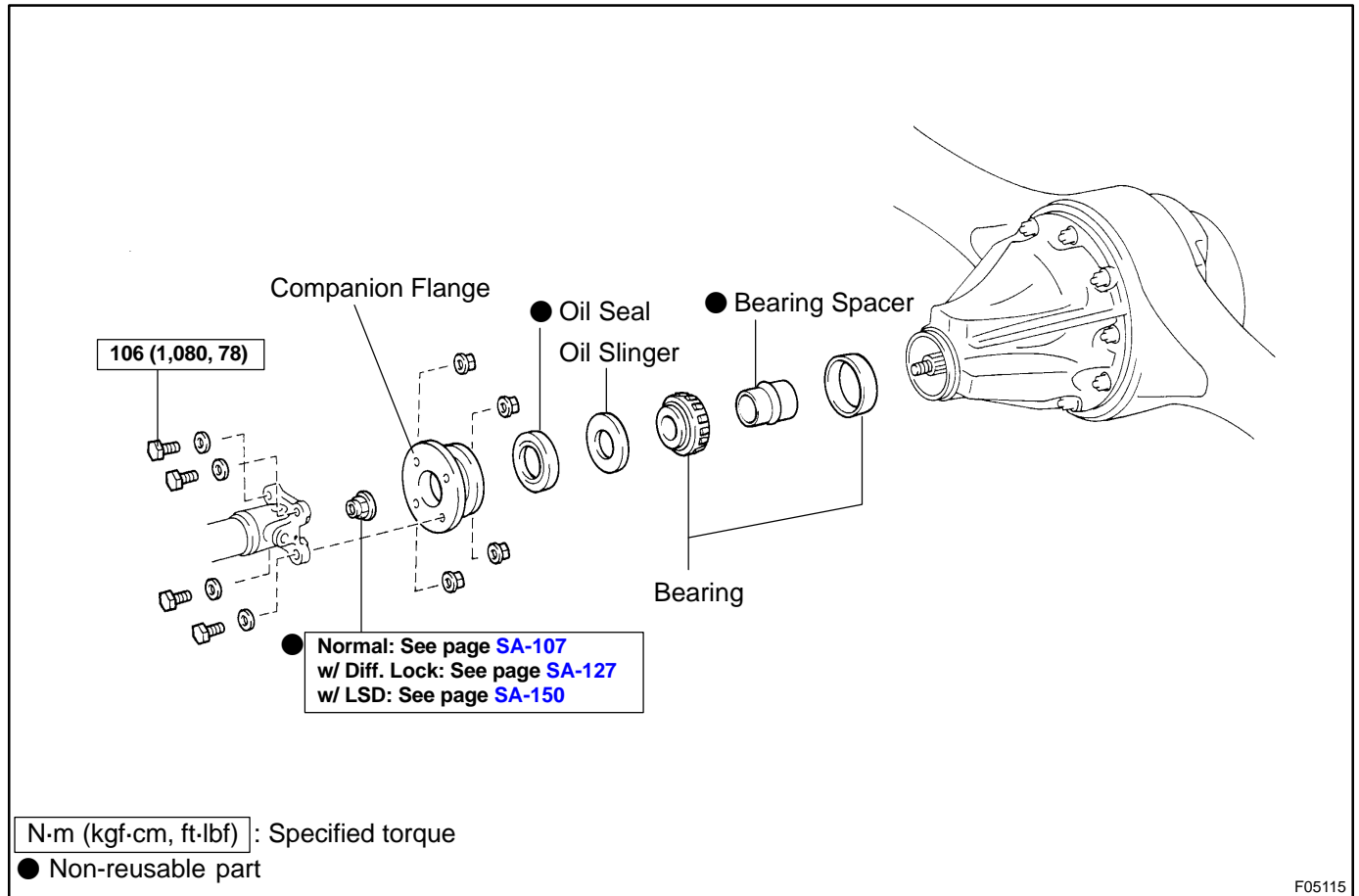

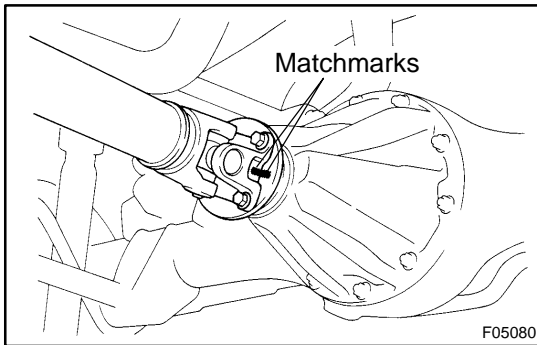

REPLACEMENT

1. DISCONNECT REAR PROPELLER SHAFT

- Place matchmarks on the propeller shaft and companion flange.
- Remove the 4 nuts, bolts, washers and disconnect the propeller shaft.
- Support the propeller shaft securely.

2. DRAIN HYPOID GEAR OIL

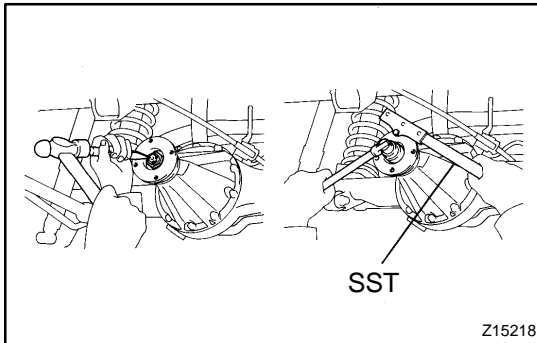

3. REMOVE COMPANION FLANGE

- Using a chisel and hammer, unseat the nut.
- Using SST to hold the flange, remove the nut.
SST 09330-00021

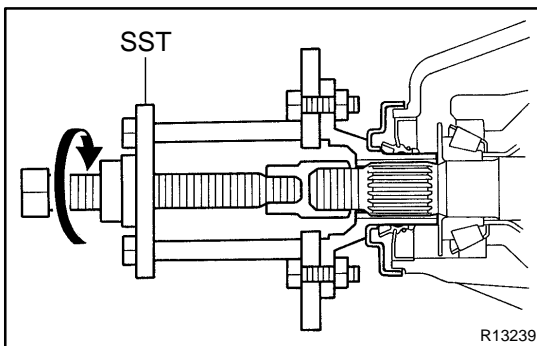

- Using SST, remove the companion flange.
SST 09950-30012 (09951-03010, 09953-03010, 09954-03010, 09955-03030, 09956-03040)

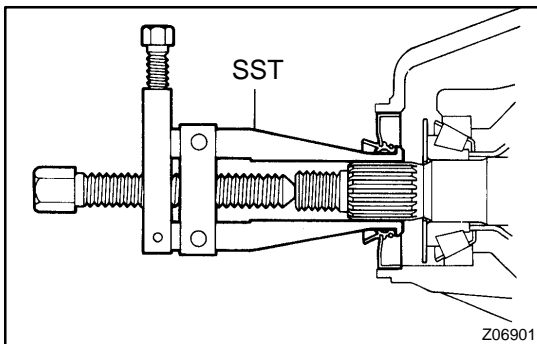

4. REMOVE OIL SEAL AND OIL SLINGER

- Using SST, remove the oil seal.
SST 09308-10010
- Remove the oil slinger.

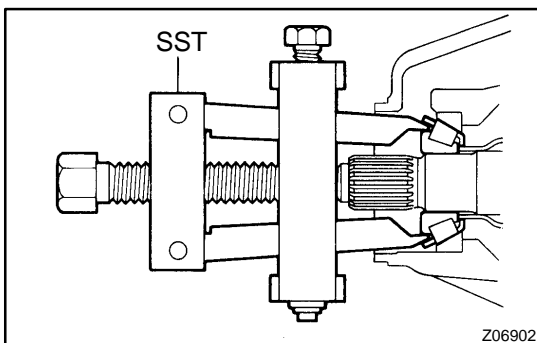

5. REMOVE FRONT BEARING

- Using SST, remove the front bearing from the drive pinion.
SST 09556-22010

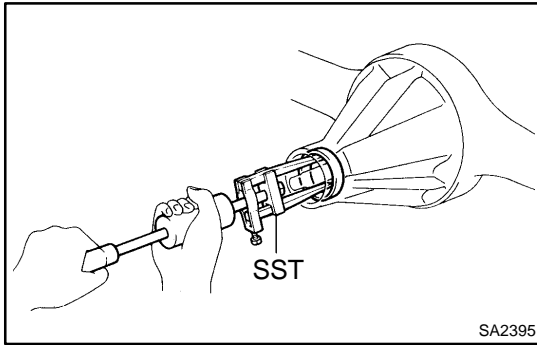
**6. REMOVE BEARING OUTER RACE**

Using SST, remove the bearing outer race.
SST 09308-00010

NOTICE:

Do not scratch the taper surface of the outer race.

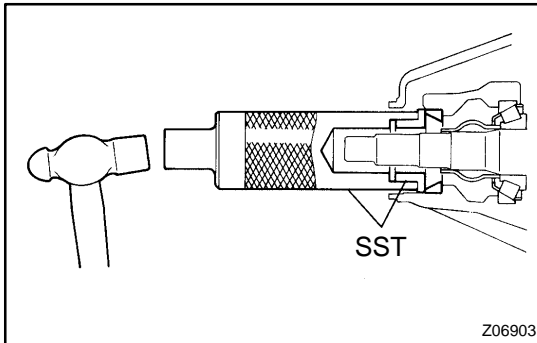
7. REMOVE BEARING SPACER**8. INSTALL NEW BEARING SPACER****9. INSTALL BEARING OUTER RACE**

Using SST and a hammer, install the bearing outer race.
SST 09316-6001 1 (09316-00011, 09316-00021)

10. INSTALL FRONT BEARING**11. INSTALL OIL SLINGER AND OIL SEAL**

(a) Install the oil slinger.

(b) Coat the hypoid gear oil to a new oil seal periphery.

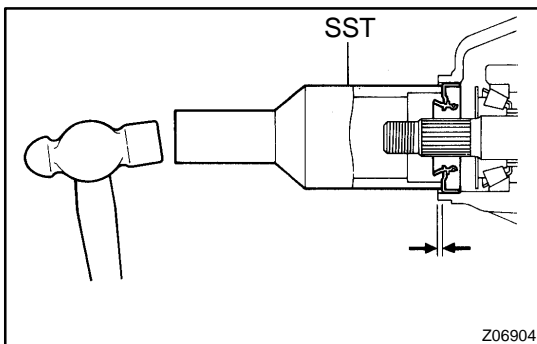

(c) Using SST and a hammer, install the new oil seal.
SST 09214-7601 1

Oil seal drive in depth: 0.5 mm (0.020 in.)

(d) Coat MP grease to the oil seal lip.

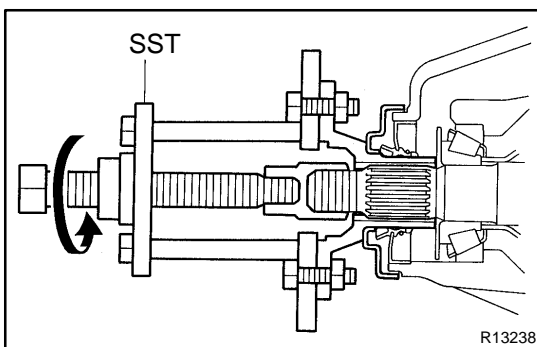
**12. INSTALL COMPANION FLANGE**

(a) Using SST, install the companion flange on the drive pinion.

SST 09950-30012 (09951-03010, 09953-03010, 09954-03010, 09955-03030, 09956-03040)

(b) Coat the threads of a new companion flange nut with gear oil.

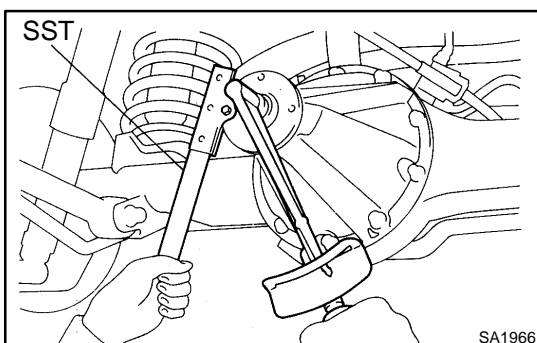

(c) Using SST to hold the flange, install a new nut.
SST 09330-00021

Torque: 245 N·m (2,500 kgf·cm, 181 ft·lbf)

13. ADJUST DRIVE PINION PRELOAD

(See page [SA-107](#), [SA-127](#) or [SA-150](#))

14. STAKE DRIVE PINION NUT**15. CONNECT REAR PROPELLER SHAFT**

(a) Align the matchmarks on the propeller shaft and flange.

(b) Install the 4 bolts, washers and nuts.

Torque: 106 N·m (1,080 kgf·cm, 78 ft·lbf)

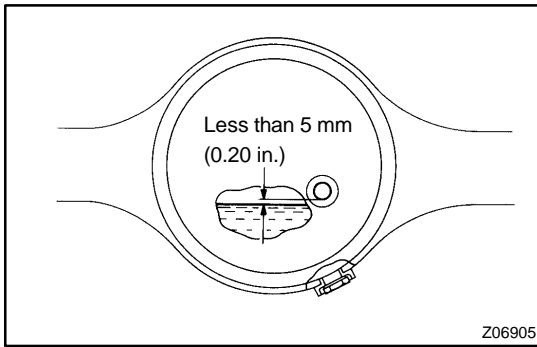
**16. FILL DIFFERENTIAL WITH HYPOID GEAR OIL****Torque: 49 N·m (500 kgf-cm, 36 ft-lbf)****Oil type:****w/o LSD: Hypoid gear oil API GL-5****w/ LSD: Hypoid gear oil LSD API GL-5****Recommended oil viscosity:****Above -18°C (0°F) SAE 90****Below -18°C (0°F) SAE 80W-90 or 80W****Capacity:****w/ Diff. Lock: 3.20 liters (3.38 US qts, 2.82 Imp.qts)****Others: 3.30 liters (3.49 US qts, 2.90 Imp.qts)**

REAR LATERAL CONTROL ROD COMPONENTS

SA16F-02

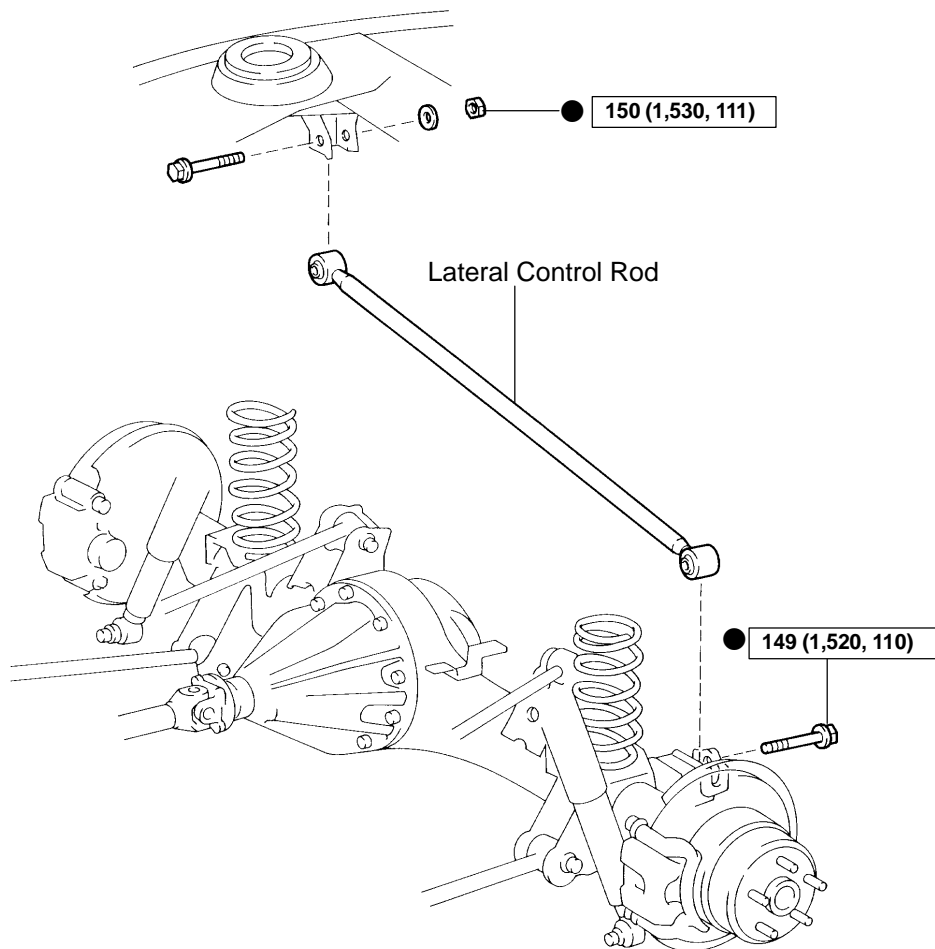

N·m (kgf·cm, ft·lbf) : Specified torque

● Non-reusable part

F05238

INSTALLATION

Installation is in the reverse order of removal (See page [SA-179](#)).

REMOVAL

1. SUPPORT REAR AXLE HOUSING WITH JACK

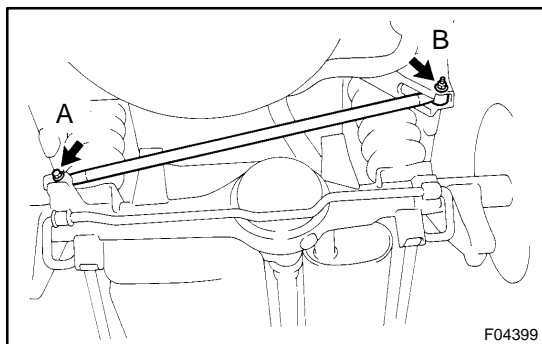

2. REMOVE LATERAL CONTROL ROD

Remove the 2 bolts, nut, washer and lateral control rod.

Torque:

A: 149 N·m (1,520 kgf·cm, 110 ft·lbf)

B: 150 N·m (1,530 kgf·cm, 111 ft·lbf)

HINT:

At the time of installation, after stabilizing the suspension, torque the nut and bolt.

REAR STABILIZER BAR COMPONENTS

SA16L-02

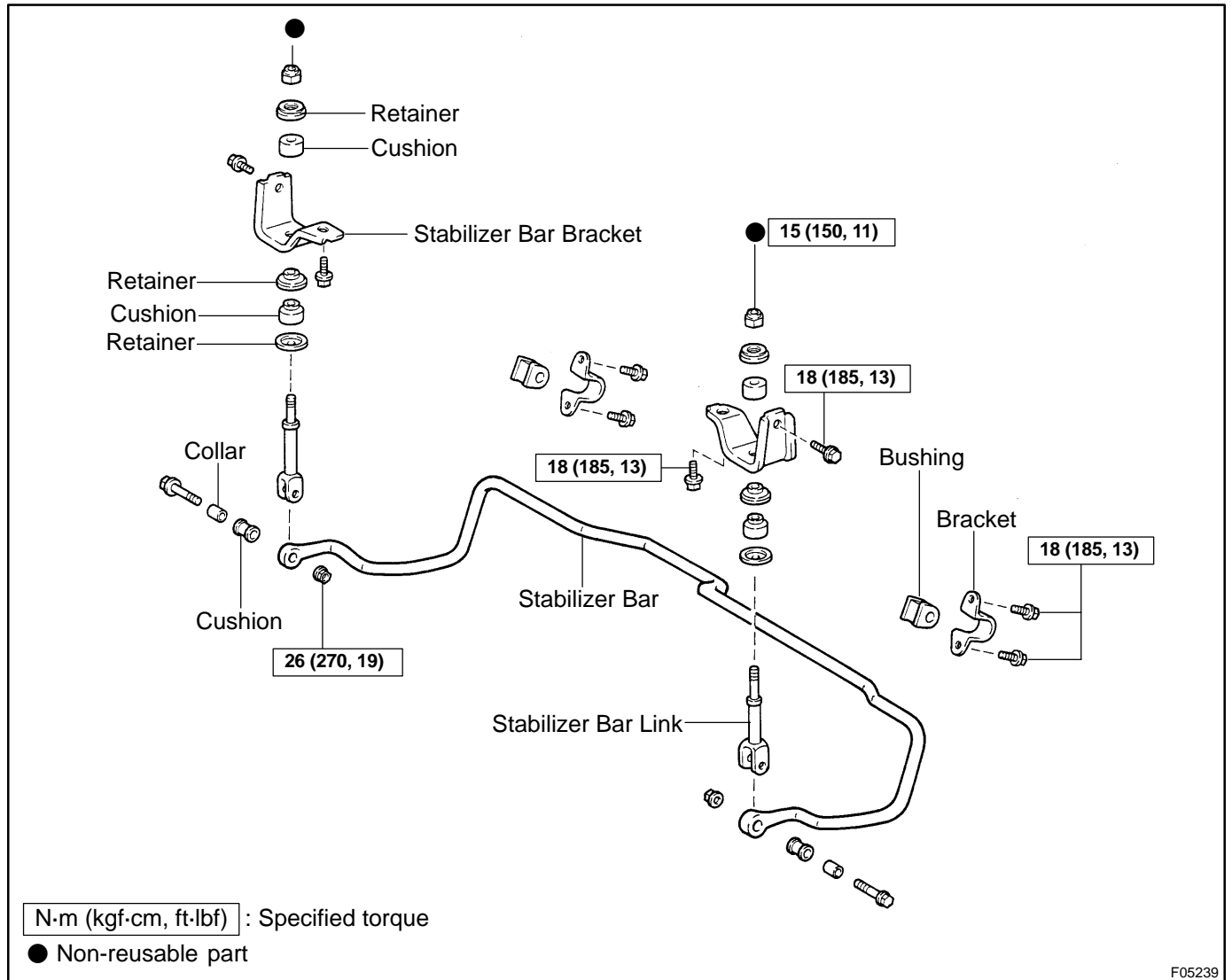

REMOVAL

1. REMOVE REAR WHEELS
Torque: 131 N·m (1,340 kgf·cm, 97 ft·lbf)
2. SUPPORT REAR AXLE HOUSING WITH JACK

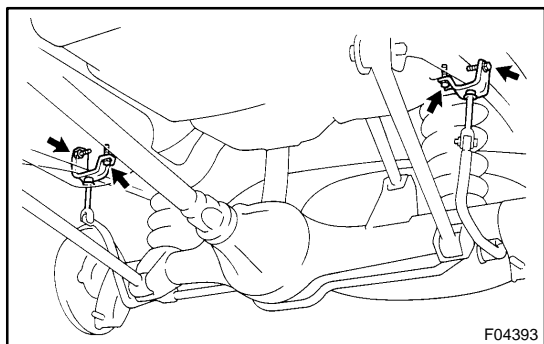

3. DISCONNECT LH AND RH STABILIZER BAR BRACKETS

Remove the 4 bolts and disconnect the LH and RH stabilizer bar brackets.

Torque: 18 N·m (185 kgf·cm, 13 ft·lbf)

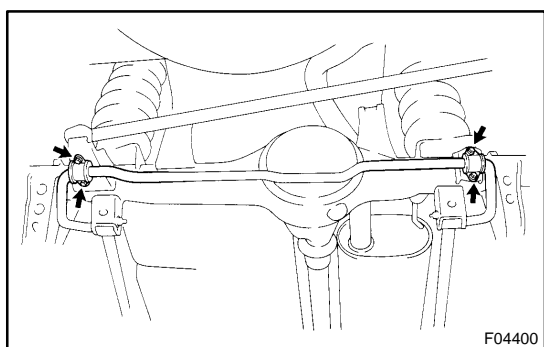

4. REMOVE STABILIZER BAR

(a) Remove the 4 bolts and stabilizer bar with the bushings and brackets.

Torque: 18 N·m (185 kgf·cm, 13 ft·lbf)

(b) Remove the 2 brackets and 2 bushings from the stabilizer bar.

5. REMOVE BOTH STABILIZER BAR LINKS FROM STABILIZER BAR

(a) Remove the nut, 3 retainers, 2 cushions and disconnect the stabilizer bar link from the bracket.

Torque: 15 N·m (150 kgf·cm, 11 ft·lbf)

(b) Employ the same manner described above to the other side.

(c) Remove the 2 nuts, bolts and stabilizer bar links.

Torque: 26 N·m (270 kgf·cm, 19 ft·lbf)

(d) Remove the 2 collars and cushions.

REAR UPPER AND LOWER CONTROL ARM COMPONENTS

SA16I-02

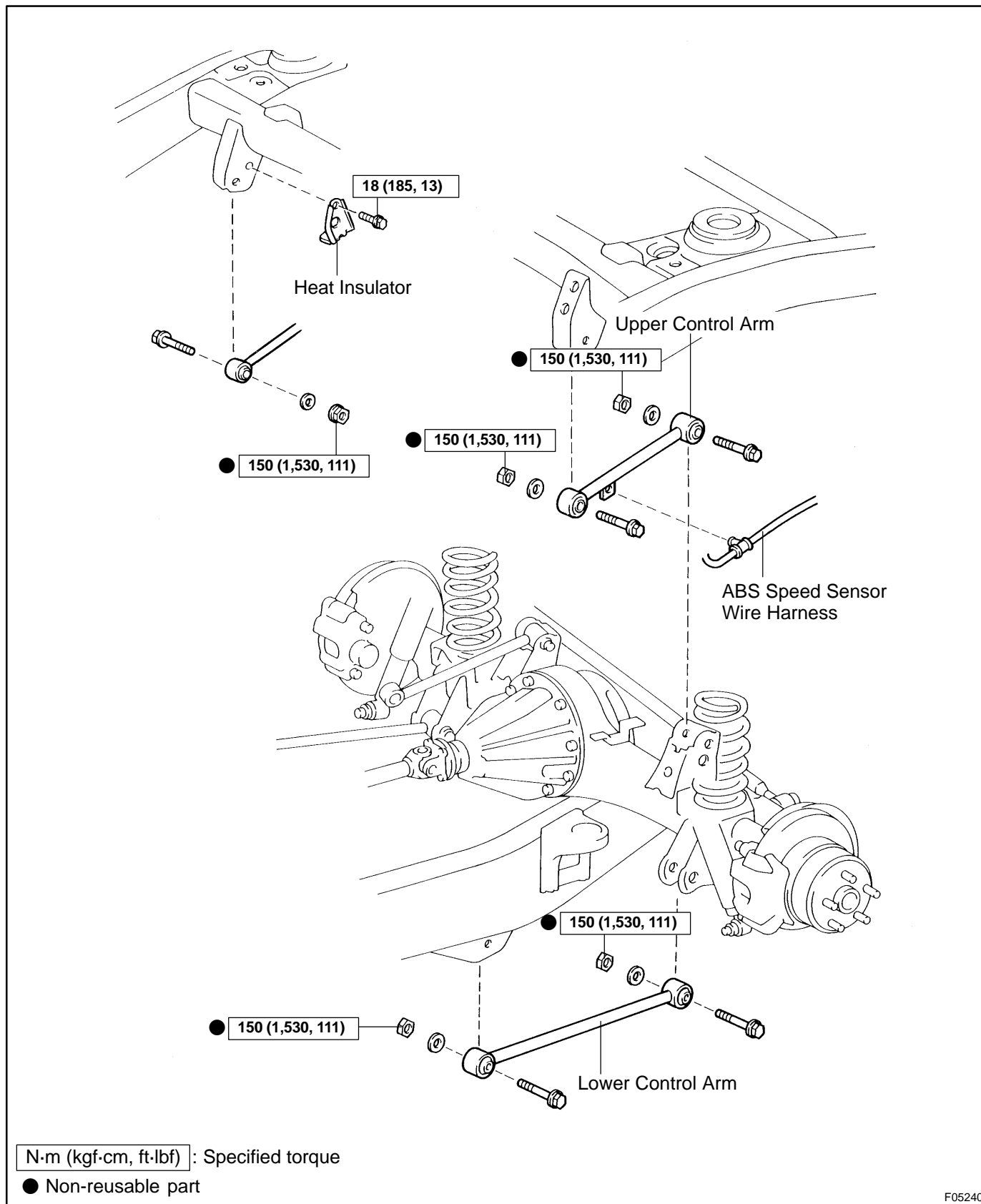

F05240

INSTALLATION

Installation is in the reverse order of removal (See page [SA-182](#)).

REMOVAL

1. REMOVE REAR WHEEL

Torque: 131 N·m (1,340 kgf·cm, 97 ft·lbf)

2. SUPPORT REAR AXLE HOUSING WITH JACK

3. REMOVE UPPER CONTROL ARM

(a) Disconnect the ABS speed sensor wire harness.

(b) RH side:

Remove the bolt and heat insulator.

Torque: 18 N·m (185 kgf·cm, 13 ft·lbf)

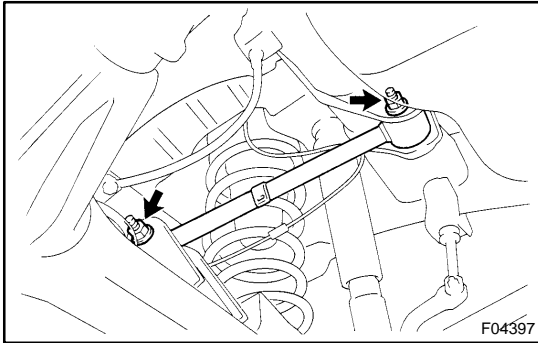

(c) Remove the 2 nuts, washers, bolts and upper control arm.

Torque: 150 N·m (1,530 kgf·cm, 111 ft·lbf)

HINT:

At the time of installation, after stabilizing the suspension, torque the nuts.

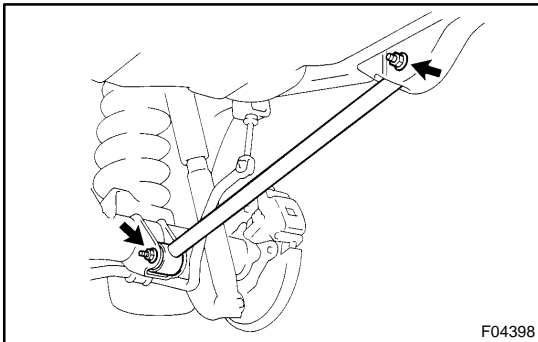

4. REMOVE LOWER CONTROL ARM

Remove the 2 nuts, washers, bolts and lower control arm.

Torque: 150 N·m (1,530 kgf·cm, 111 ft·lbf)

HINT:

At the time of installation, after stabilizing the suspension, torque the nuts.

REAR WHEEL HUB BOLT REPLACEMENT

SA15J-02

1. REMOVE REAR WHEEL

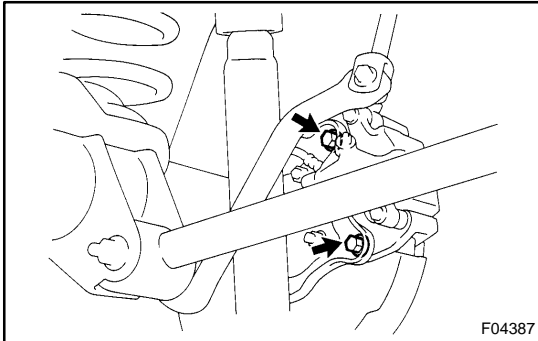

2. REMOVE BRAKE CALIPER AND DISC

- Remove the 2 bolts, brake caliper and disc.
- Support the brake caliper securely.

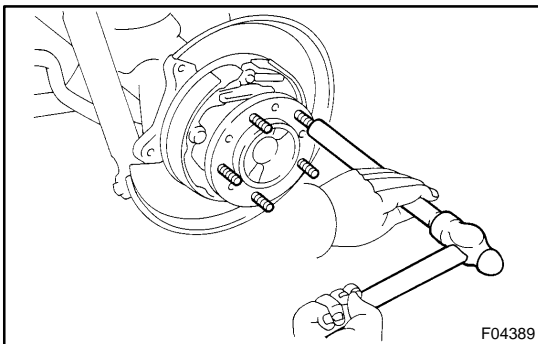

3. REMOVE HUB BOLT

Using a brass bar and hammer, remove the hub bolt.

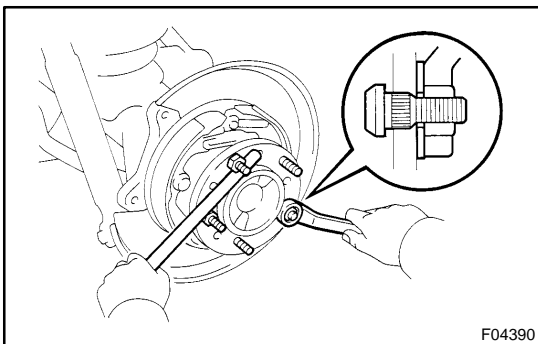

4. INSTALL HUB BOLT

Install a washer and nut to a new hub bolt, as shown in the illustration, and install the hub bolt by torquing the nut.

5. INSTALL DISC AND BRAKE CALIPER

Install the disc and brake caliper with the 2 bolts.

Torque: 103 N·m (1,050 kgf·cm, 76 ft·lbf)

6. INSTALL REAR WHEEL

Torque: 131 N·m (1,340 kgf·cm, 97 ft·lbf)

STEERING KNUCKLE COMPONENTS

SA149-05

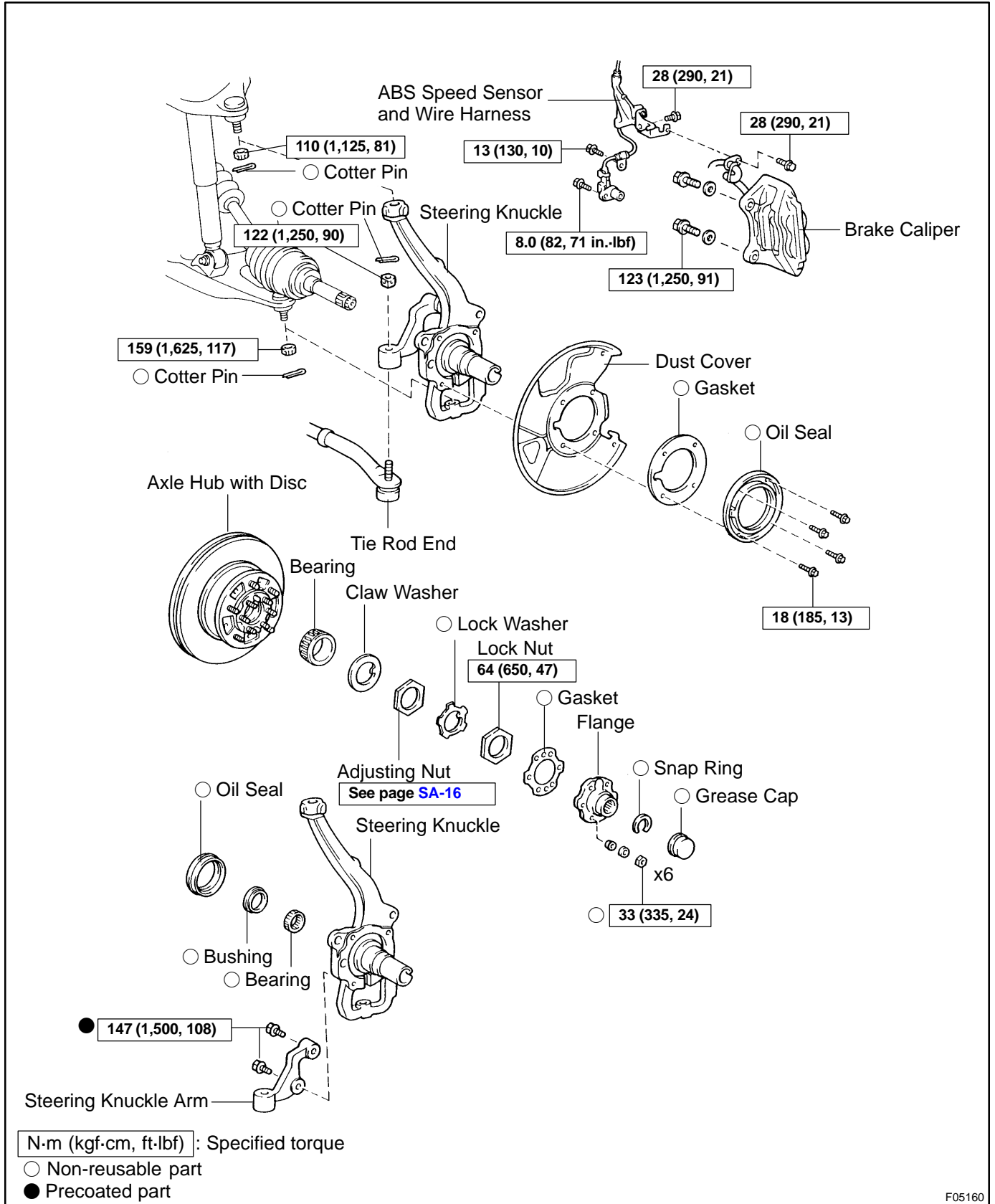

F05160

DISASSEMBLY

1. REMOVE STEERING KNUCKLE ARM

Remove the 2 bolts and steering knuckle arm.

2. REMOVE OIL SEAL

Using a screwdriver and hammer, remove the oil seal.

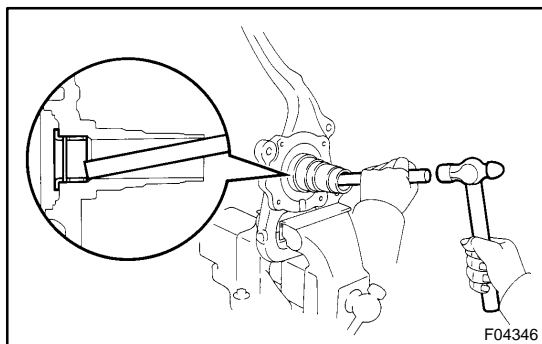

3. REMOVE BEARING AND BUSHING

Using a brass and hammer, remove the bearing and bushing.

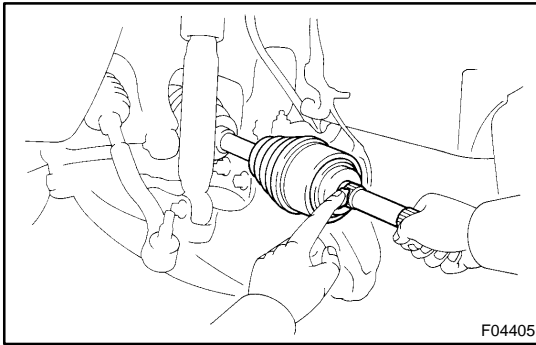

INSTALLATION

1. INSTALL STEERING KNUCKLE

- (a) Apply synthetic oil and lithium soap base chassis grease, NLGI No. 1 to the drive shaft.
- (b) Support the lower suspension arm with jack and connect the steering knuckle to the lower suspension arm.

NOTICE:

Be careful not to damage the oil seal.

- (c) Temporarily install the nut to lower suspension arm.
- (d) Raise up the lower suspension arm using a jack and install the steering knuckle to the upper suspension arm with a nut.

Torque: 110 N·m (1,125 kgf·cm, 81 ft·lbf)

- (e) Install a new cotter pin.

If the holes for the cotter pin are not aligned, tighten the nut further up to 60°.

- (f) Torque the nut of the lower suspension arm.

Torque: 159 N·m (1,625 kgf·cm, 117 ft·lbf)

- (g) Install a new cotter pin.

2. CONNECT TIE ROD END

- (a) Connect the tie rod end to steering knuckle with nut.

Torque: 122 N·m (1,250 kgf·cm, 91 ft·lbf)

- (b) Install a new cotter pin.

If the holes for the cotter pin are not aligned, tighten the nut further up to 60°.

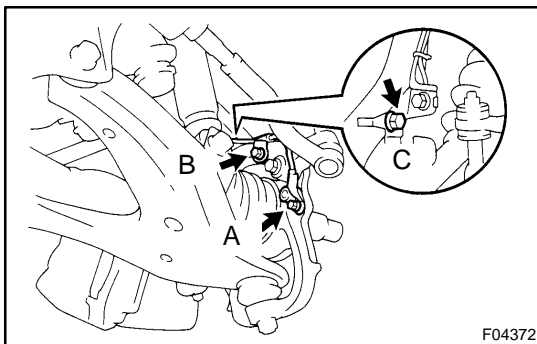

3. CONNECT ABS SPEED SENSOR AND WIRE HARNESS

Install the wire harness and 3 bolts.

Torque:

A: 8.0 N·m (82 kgf·cm, 71 in.-lbf)

B: 13 N·m (130 kgf·cm, 10 ft·lbf)

C: 28 N·m (290 kgf·cm, 21 ft·lbf)

4. INSTALL DUST COVER, GASKET AND OIL SEAL

Install the dust cover, new gasket and oil seal with the 4 bolts.

Torque: 18 N·m (185 kgf·cm, 13 ft·lbf)

5. INSTALL FRONT AXLE HUB (See page SA-16)

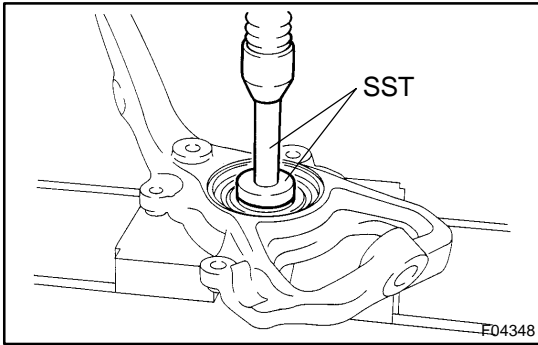

REASSEMBLY

1. INSTALL BEARING AND BUSHING

- (a) Using SST and a press, install a new bearing and bushing.
SST 09950-60010 (09951-00540),
09950-70010 (09951-07100)
- (b) Apply synthetic oil and lithium soap base chassis grease, NLGI No. 1 to the steering knuckle inner side of the bushing.

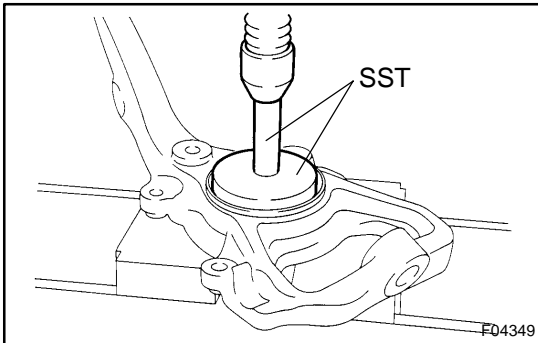

2. INSTALL OIL SEAL

- (a) Using SST and a press, install a new oil seal.
SST 09950-60020 (09951-00910),
09950-70010 (09951-07100)
- (b) Coat the lip of the oil seal with MP grease.

3. INSTALL STEERING KNUCKLE ARM

- (a) Clean the threads of the 2 bolts and steering knuckle with toluene or trichloroethylene.
- (b) Apply sealant to the bolt threads.

Sealant:

Part No. 08833-00070, THREE BOND 1324 or equivalent

- (c) Install the steering knuckle arm with the 2 bolts.
Torque: 147 N·m (1,500 kgf·cm, 108 ft·lbf)

REMOVAL

1. REMOVE FRONT AXLE HUB (See page SA-12)

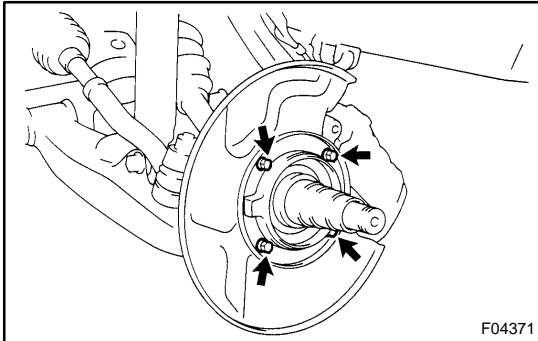

2. REMOVE OIL SEAL, GASKET AND DUST COVER

Remove the 4 bolts, oil seal, gasket and dust cover.

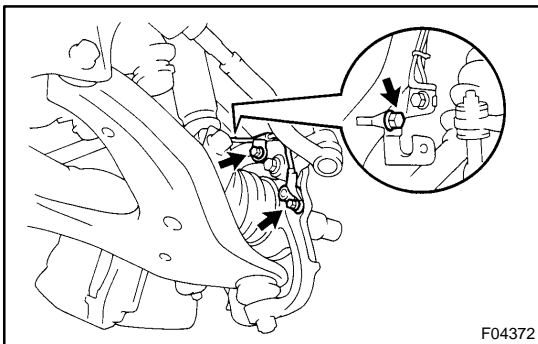

3. DISCONNECT ABS SPEED SENSOR AND WIRE HARNESS

Remove the 3 bolts and disconnect the ABS speed sensor and wire harness.

4. DISCONNECT TIE ROD END FROM STEERING KNUCKLE ARM

(a) Remove the cotter pin and nut.

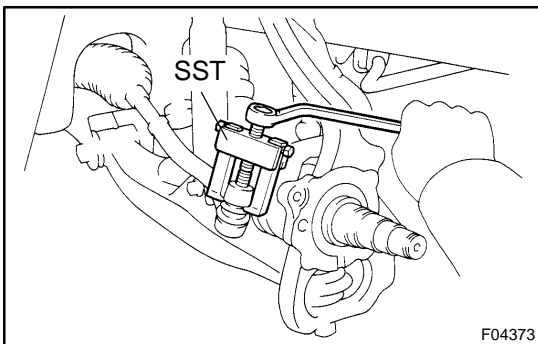

(b) Using SST, disconnect the tie rod end from the steering knuckle arm.

SST 09628-6201 1

5. DISCONNECT LOWER SUSPENSION ARM FROM STEERING KNUCKLE

(a) Remove the cotter pin and nut.

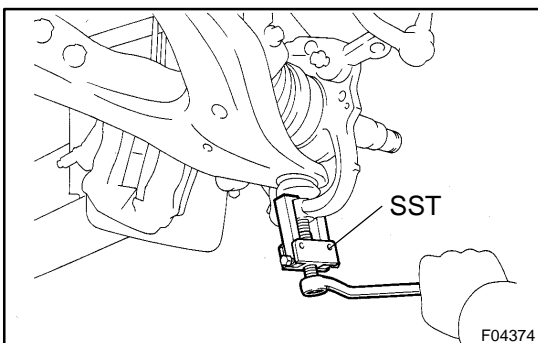

(b) Using SST, disconnect the lower suspension arm from the steering knuckle.

SST 09628-6201 1

6. REMOVE STEERING KNUCKLE

(a) Remove the cotter pin and nut.

(b) Temporarily install the nut to the lower suspension arm.

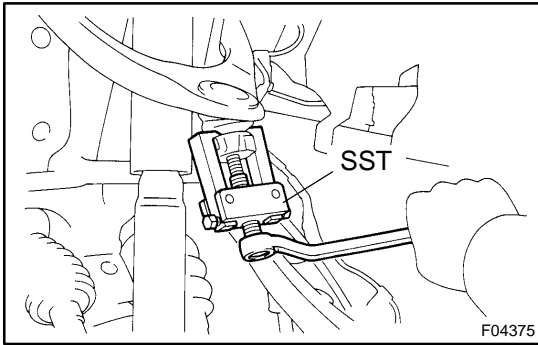

- (c) Using SST, disconnect the steering knuckle from the upper suspension arm.
SST 09628-6201 1
- (d) Remove the nut and steering knuckle from the lower suspension arm.

TIRE AND WHEEL INSPECTION

1. INSPECT TIRE

(a) Check the tires for wear and proper inflation pressure.

Cold tire inflation pressure:

Tire size	Front kPa (kgf/cm ² , psi)	Rear kPa (kgf/cm ² , psi)
P275/70R16	200 (2.0, 29) *220 (2.2, 32)	220 (2.2, 32) *240 (2.4, 35)

*: Trailer towing

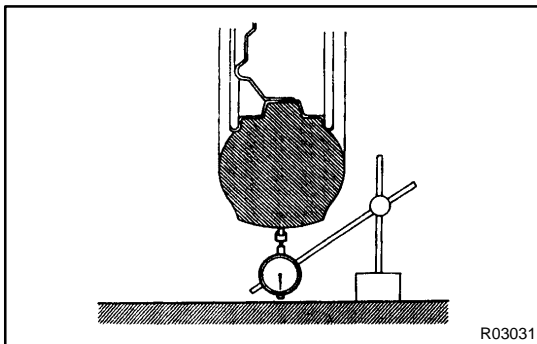

(b) Check the tire runout.

Tire runout: 3.0 mm (0.118 in.) or less

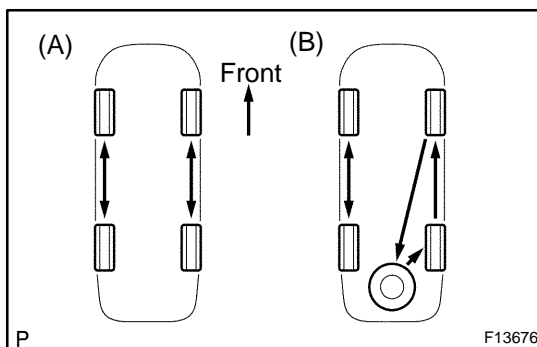

2. ROTATE TIRE

HINT:

- Rotate tires as shown in the illustration.
- Rotate as shown in (B) if the spare tire is included in the rotation.

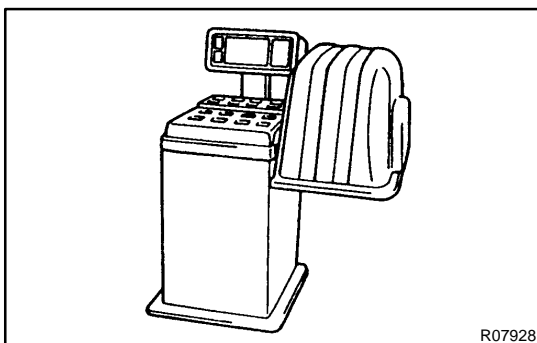

3. INSPECT WHEEL BALANCE

(a) Check and adjust the Off-the car balance.

(b) If necessary, check and adjust the On-the car balance.

Imbalance after adjustment: 14.0 g (0.031 lb) or less

4. **CHECK FRONT SUSPENSION FOR LOOSENESS**
5. **CHECK STEERING LINKAGE FOR LOOSENESS**
6. **CHECK BALL JOINT FOR LOOSENESS**
7. **CHECK SHOCK ABSORBER WORKS PROPERLY**
 - Check that oil leaks
 - Check the mounting bushings for wear
 - Bounce front and rear of the vehicle

TROUBLESHOOTING

PROBLEM SYMPTOMS TABLE

SA140-09

Use the table below to help you find the cause of the problem. The numbers indicate the priority of the likely cause of the problem. Check each part in order. If necessary, replace these parts.

(w/ Differential locking system):

- **Check that the transfer shift lever is shifted to the L position.**
- **When switching differential Free ↔ Lock, the indicator light will blink if the gears of the differential lock sleeve are not meshed. If this occurs, when the tires are rotated to apply differential power to the differential, the differential locks and the indicator light lights up.**

Symptom	Suspect Area	See page
Bottoming	<ol style="list-style-type: none"> 1. Vehicle (Overloaded) 2. Spring (Weak) 3. Shock absorber (Worn) 	- SA-65 SA-171 SA-62 SA-174
Sways/pitches	<ol style="list-style-type: none"> 1. Tire (Worn or improperly inflated) 2. Stabilizer bar (Bent or broken) 3. Shock absorber (Worn) 	SA-4 SA-80 SA-184 SA-62 SA-174
Front wheel shimmy	<ol style="list-style-type: none"> 1. Tire (Worn or improperly inflated) 2. Wheel (Out of balance) 3. Shock absorber (Worn) 4. Wheel alignment (Incorrect) 5. Ball joint (Worn) 6. Hub bearing (Loosen or worn) 7. Steering linkage (Loosen or worn) 8. Steering gear (Out of adjustment or broken) 	SA-4 SA-4 SA-62 SA-6 SA-71 SA-76 SA-11 - SR-48
Abnormal tire wear	<ol style="list-style-type: none"> 1. Tire (Improperly inflated) 2. Wheel alignment (Incorrect) 3. Shock absorber (Worn) 4. Suspension parts (Worn) 	SA-4 SA-6 SA-62 SA-174 -
Noise in front differential	<ol style="list-style-type: none"> 1. Oil level (Low or wrong grade) 2. Excessive backlash between pinion and ring gear 3. Ring, pinion or side gears (Worn or chipped) 4. Pinion shaft bearing (Worn) 5. Side bearing (Worn) 	SA-35 SA-40 SA-40 SA-40 SA-40
Oil leak from front differential	<ol style="list-style-type: none"> 1. Oil level (Too high or wrong grade) 2. Front differential rear oil seal (Worn or damaged) 3. Side gear oil seal (Worn or damaged) 4. Companion flange (Loosen or damaged) 5. Side gear shaft (Damaged) 	SA-35 SA-40 SA-40 SA-40 SA-40

Noise in rear axle	<ol style="list-style-type: none"> 1. Oil level (Low or wrong grade) 2. Excessive backlash between pinion and ring gear 3. Ring, pinion or side gears (Worn or chipped) 4. Pinion shaft bearing (Worn) 5. Axle shaft bearing (Worn) 	<p>SA-95 SA-102 SA-121 SA-143 SA-102 SA-121 SA-143 SA-102 SA-121 SA-143 SA-83</p>
Oil leak from rear axle	<ol style="list-style-type: none"> 1. Oil seal (Worn or damaged) 2. Rear axle housing (Cracked) 	<p>SA-83 -</p>
Oil leak from rear differential	<ol style="list-style-type: none"> 1. Oil level (Too high or wrong grade) 2. Rear differential front oil seal (Worn or damaged) 3. Companion flange (Loosen or damaged) 	<p>SA-95 SA-95 SA-102 SA-121 SA-143</p>
Diff. lock Indicator lights do not light up	<ol style="list-style-type: none"> 1. Fusible link (Blown) 2. GAUGE fuse (Blown) 3. Bulb (Burned out) 4. Wiring or ground (Faulty) 	<p>- - - -</p>
Diff. lock Indicator lights do not light up (Diff. lock control switch RR position)	<ol style="list-style-type: none"> 1. Diff. fuse (Blown) 2. Diff. lock control switch (Faulty) 3. Diff. lock ECU (Faulty) 4. Wiring or ground (Faulty) 	<p>- SA-163 SA-163 -</p>
Differential lock does not operate	<ol style="list-style-type: none"> 1. Diff. lock control switch (Faulty) 2. Diff. lock actuator (Faulty) 3. Diff. lock ECU (Faulty) 4. Differential carrier (Faulty) 5. Wiring or ground (Faulty) 	<p>SA-163 SA-163 SA-163 - -</p>
After differential lock, lock is not released When vehicle speed is at 8 km/h (5 mph) or more	<ol style="list-style-type: none"> 1. Speed sensor (Faulty) 2. Diff. lock ECU (Faulty) 3. Wiring or ground (Faulty) 	<p>SA-163 SA-163 -</p>

REPAIR PROCEDURES

HINT:

This is a flow chart for vehicle pull.

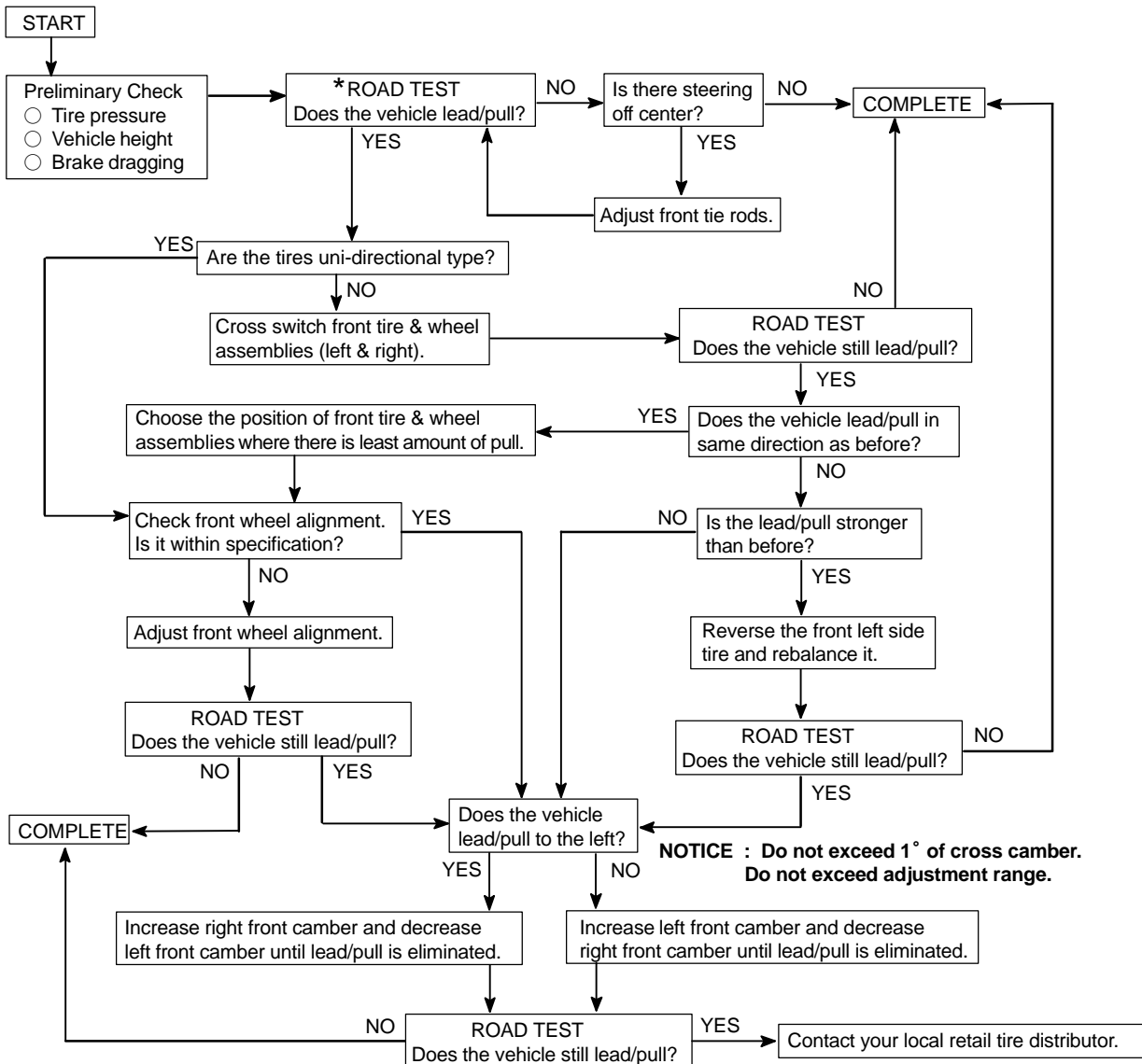

* Select a flat road where the vehicle can be driven in a straight line for 100 meters at a constant speed of 35mph. Please confirm safety and set the steering wheel to its straight position. Drive the vehicle in a straight line for 100 meters at a constant speed of 35mph without holding the steering wheel.

(1) The vehicle can keep straight but the steering wheel has some angle. —> STEERING OFF CENTER (See page SR-10)

(2) The vehicle cannot keep straight. —> STEERING PULL