

MANUAL  
of Operating & Maintenance  
Procedures  
for

AN3100  
SECONDARY DC VOLTAGE STANDARD

**ANALOGIC**   
...The Digitizers

AUDUBON ROAD, WAKEFIELD, MASSACHUSETTS  
TELEPHONE (617) 246-0300, TWX (710) 348-0425



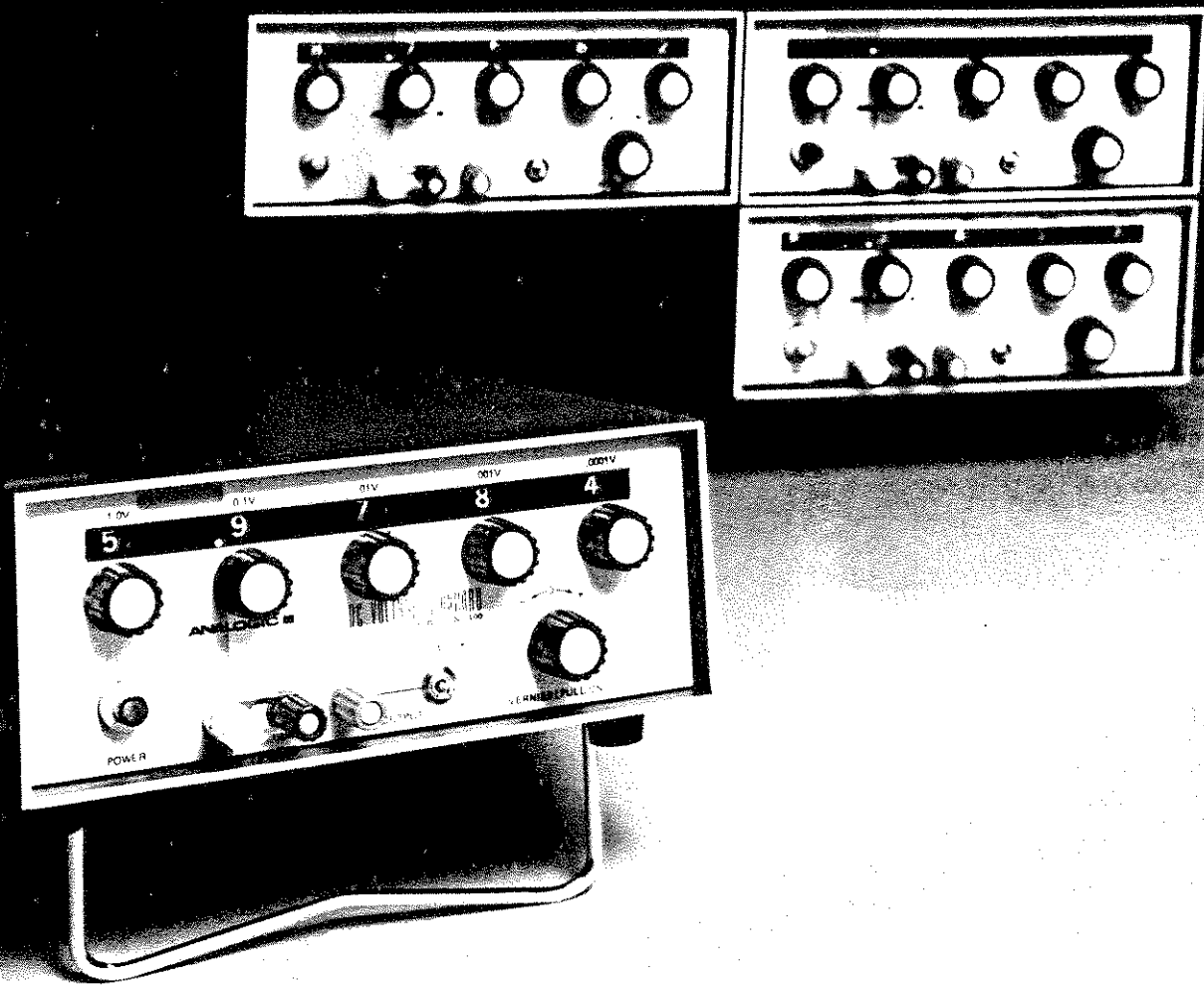

1  
2  
3  
4  
5  
6  
7  
8  
9  
10  
11  
12  
13  
14  
15  
16  
17  
18  
19  
20  
21  
22  
23  
24  
25  
26  
27  
28  
29  
30  
31  
32  
33  
34  
35  
36  
37  
38  
39  
40  
41  
42  
43  
44  
45  
46  
47  
48  
49  
50  
51  
52  
53  
54  
55  
56  
57  
58  
59  
60  
61  
62  
63  
64  
65  
66  
67  
68  
69  
70  
71  
72  
73  
74  
75  
76  
77  
78  
79  
80  
81  
82  
83  
84  
85  
86  
87  
88  
89  
90  
91  
92  
93  
94  
95  
96  
97  
98  
99  
100

MANUAL  
of Operating & Maintenance  
Procedures  
for

AN3100  
SECONDARY DC VOLTAGE STANDARD

**ANALOGIC**  <sup>®</sup>

...The Digitizers

AUDUBON ROAD, WAKEFIELD, MASSACHUSETTS  
TELEPHONE (617) 246-0300, TWX (710) 348-0425

**AN3100**  
**INSTRUCTION MANUAL**  
**TABLE OF CONTENTS**

1.	Introduction	1
1.1	General Description	1
1.2	Certificate of Conformance	1
1.3	Specifications	2
2.	Operating Instructions	5
2.1	Unpacking	5
2.2	Operating Controls and Indicators	5
2.2.1	Front Panel Controls and Indicators	5
2.3	Operation	7
2.3.1	Warmup	8
2.3.2	Grounding	8
2.3.3	Output Impedance and Loading	10
3.	Principles of Operation	11
3.1	Calibrated Output	11
3.2	Functional Block Diagram	11
3.2.1	AC Input Circuit	11
3.2.2	Power Supplies	11
3.2.3	Servo Loop Voltage References	11
3.2.4	Block Diagram	12
3.2.5	Vernier Control	14
3.2.6	Chopper Stabilized Amplifier	15
3.2.7	Output Circuit	15
4.	Maintenance	17
4.1	Recalibration	17
4.2	Field Maintenance	17
5.	Parts List and Schematic Diagram	21

## 1. Introduction

The Secondary DC Voltage Standard is delivered fully calibrated and ready to serve within its certified accuracy for a duration of six months before requiring recalibration against primary standards. After unpacking, the line voltage selector switch on the rear panel should be set to 115 or 230 volts, as appropriate. The AN3100 is ready for use; however, material in this manual will be informative and valuable for proper instrument application.

### 1.1 General Description

#### 1.1.1 Review of AN3100 Features:

- Dual five decade output ranges  
±11.1110 Volts DC with 100- $\mu$ V resolution; Main Output (Front Panel Terminals)  
±11.1110 Millivolts DC with 1- $\mu$ V resolution; Auxiliary Output (Rear Panel Terminals)
- Accuracy 0.005% of reading  $\pm 50 \mu\text{V}$  @ 20°C  $\pm 0.0002\%/^{\circ}\text{C}$
- Warmup to rated accuracy in less than 10 minutes
- High output current of 50 mA; short circuit-proof
- 10-milliohm output impedance (100 ohms on low output range)
- No maximum external load capacity
- Isolated circuitry is unaffected by common mode voltages up to  $\pm 500 \text{ V}$
- Front panel  $\pm 1 \text{ mV}$  vernier

#### 1.1.2 Review of Your New In-House Capability:

Because of the portability and fast warm up of the AN3100 you can use it on site to:

- Calibrate absolutely to 50 PPM
- Normalize to 25 PPM
- Standardize to 15 PPM
- Verify linearity to 25 PPM
- Monitor drift to 5 PPM
- Establish regulation to  $\pm 1 \mu\text{V}$

### 1.2 Certificate of Conformance

A certificate of conformance containing factory inspection test results is packed with each AN3100 DC Voltage Standard. This document should be retained in a log or file record for this instrument. It will serve to assure the NBS traceability of absolute accuracy, to provide a table of output voltages for recalibration comparisons, and to outline the factory test procedures used in determining these values.

### 1.3 Specifications

#### OUTPUT CHARACTERISTICS

##### VOLTAGE RANGE

Main Output: 0 to  $\pm 11.1110$  volts at front terminals

Auxiliary Output: 0 to  $\pm 11.110$  millivolts at rear panel terminals

##### CURRENT CAPABILITY – MAIN OUTPUT

0 to 50 milliamperes - source. Short-circuit proof. No restrictions on load capacitance.

0 to 3 milliamperes - sink.

##### ABSOLUTE ACCURACY (at 23°C)

50 PPM of reading,  $\pm 50 \mu\text{V}$ ; includes 6-month stability and linearity; main output

150 PPM of reading,  $\pm 0.5 \mu\text{V}$ ; includes 6-month stability and linearity; auxiliary (rear-panel) output

##### LONG-TERM STABILITY:

$\pm 15$  PPM, 60 days

##### LINEARITY:

within  $\pm 25$  PPM

##### TEMPERATURE COEFFICIENT:

2 PPM/°C

##### RESOLUTION:

Main Output: 100 microvolts (5 dialable, in-line digital decades, and  $\pm 1$  mV vernier)

Auxiliary: 1 microvolt

##### OUTPUT IMPEDANCE

Main Output:

DC: 10 milliohms (max)

Dynamic:  $L \leq 10 \mu\text{H}$ ;  $R = 2\Omega$

Auxiliary Output:

DC: 100 ohms

##### NOISE:

Main Output: (0.001% of reading +  $50 \mu\text{V}$ ) p-p

##### SETTLING TIME

$V < 300$  milliseconds

##### ISOLATION

Output may be floated up to 500 VDC (maximum) above or below chassis ground.

##### WARMUP TIME

Less than 10 minutes to rated accuracy. For reduced accuracy of  $\pm 0.02\%$ , no warmup time is required.

##### RECALIBRATION INTERVAL

6 months, for rated performance



#### TEMPERATURE RANGE

Operating: 0° to +60° C  
Storage: -25° to +85° C

#### HUMIDITY

0-85% RH, non-condensing

#### POWER REQUIREMENTS

117/234 VAC, 47-420 Hz. 10 W max. (RF filter included)

#### DIMENSIONS

3-1/2"H x 8-1/2"W x 12"D (Adapter for 19" rack mounting available as an option.)  
(89mm H x 216mm W x 305mm D; Adapter = 483mm)

#### CONSTRUCTION

The AN3100 is housed in a bench-mounting, 3-1/2"H x 8-1/2"W x 12"D, aluminum-alloy case equipped with carrying handle. The five voltage decades are controlled by front-panel knobs.

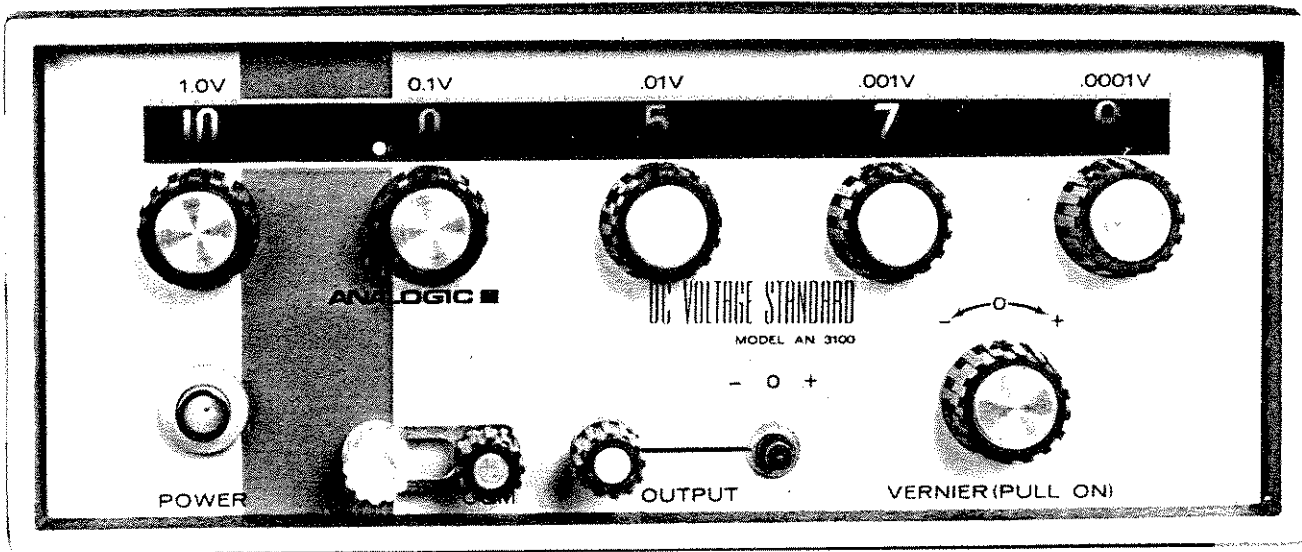

## 2. Operating Instructions

Although operation of the AN3100 DC Voltage Standard is quite straightforward, attention to the precautions outlined below will ensure optimum performance.

### 2.1 Unpacking

Immediately upon receipt of the Analogic AN3100, the carton and contents should be closely inspected for any obvious shipping abuse. Such damage should be called to the attention of the carrier immediately.

Additional checks should be made to assure that all parts are secure and that the instrument is free of rattles. A quick check of the delivery will include these components:

1. AN3100 DC Voltage Standard
2. AN3100 Instruction Manual
3. Warranty Certificate
4. NBS Traceability Certificate
5. Mating plug to MV OUTPUT socket
6. Ground link for front binding posts
7. Other options as specified on the bill of lading.

### 2.2 Operating Controls and Indicators

#### 2.2.1 Front Panel Controls and Indicators

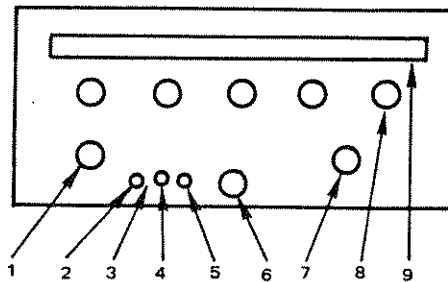

Ref.	Designation	Component	Function
1	POWER	Push-Push switch, S8	Applies AC source power to AN3100 power supply circuitry. Self-contained lamp is lit when power is ON.
2		White banana plug receptacle and binding post, J3	Provides direct connection to power cord ground wire and instrument housing.

Ref.	Designation	Component	Function
3		Shorting link	A convenience link for referencing the output voltage to ground.
4	COM	Black banana plug binding post terminal, J2	One side of output DC voltage. Low side for positive voltage output.
5	OUTPUT	Red banana plug binding post terminal, J1	One side of output DC voltage. High side for positive output.
6	(- 0 +)	Three-position switch, S6	Selects the polarity of the voltage at the red output terminal. When in the center "0" position, the DC source is disconnected from the OUTPUT and COM terminals.
7	VERNIER	Push-pull rotary knob, R27, S9	Dialed output is delivered when the knob is snapped in. Dialed output $\pm 1$ mV is delivered at main output when vernier is pulled out.
8		Eleven-position rotary decade selector switches, S1 (MSB), S2, S3, S4, S5 (LSB)	Independent selection of the values in each of 5 decades. Maximum of "10" in each position corresponds to 11.1110 volts, 330° rotation.
9	( ) V display	Five in-line rear lighted displays, DS1, DS2, DS3, DS4, DS5	Displays selected value in each decade. Eleven possible values 0 through 10, inclusive.

### 2.2.2 Rear Panel Components

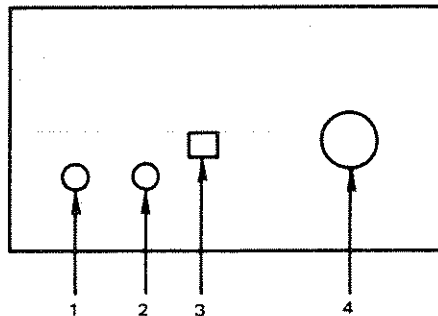

Ref.	Designation	Component	Function
1	1/4 Amp Fuse	Slotted cap fuse holder, F1	Instrument protection against AC line current in excess of 1/4 amp. Replace fuse with 3AG type.
2	AC IN	Attached 6' three-wire line cord	Power in. Case ground.
3	115/230	Slide switch, S7	Sets up transformer taps appropriate to 115V AC or 230V AC operation.
4	MV OUTPUT	Three-pin socket, J4 (Mating plug supplied)	Low range output voltage. Pin 1: Provides direct connection to power cord ground wire and instrument housing. Pin 2: Provides 1/100 of the voltage present at the Red front binding post (OUTPUT). Pin 3: Direct connection to Black binding post on front panel (COM).

### 2.3 Operation

The AN3100 is designed for simple operation. After checking to see that the unit has been preset for the appropriate AC mains voltage (115V or 230V), the unit may be connected to the power and turned on. Connections between the AN3100 and the associated circuitry should be made with a shielded twisted pair of the shortest length feasible. Good grounding practices are described in the paragraph on grounding (2.3.2).

The desired output voltage is dialed, displayed, and connected to the OUTPUT and COM terminals with the former terminal having the polarity as selected by the (- 0 +) switch. If this switch is in the center position, the reference voltage is disconnected and a short circuit will exist between these terminals.

Each dial is rotatable over 330° and stops at any one of eleven detents (zero to ten inclusive). Note by comparison the ease of stepping voltages as compared to the usual decade switch. To increase the output from 1.0999V to 1.1000V the procedure would be:

Usual decade:	1.0999	AN3100 decade:	1.0 9 9 9
	1.1000		1.0 0 0 10

#### Value of Output Voltage in Scientific Notation

Let: D = Displayed Digit

Then: on any decade  $0 \leq D \leq 10$

And:  $E_{out} = D \cdot 10^x$       The value of x corresponds to the dial position and whether the front or rear output voltage is being considered (see box next page).

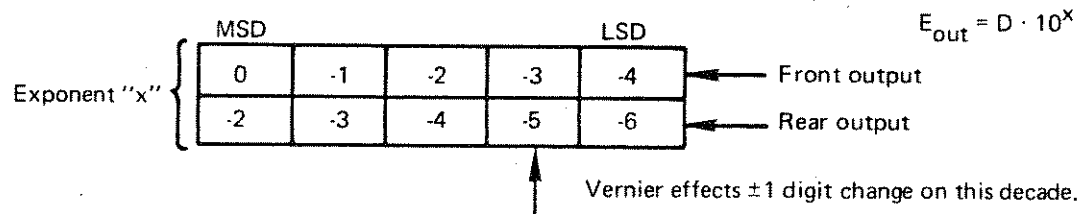

### 2.3.1 Warmup

The AN3100 warms up to full rated accuracy within ten minutes of turn on. This is the time that is required for the oven temperature to stabilize. Output voltages are available for immediate use after turn-on but at a reduced accuracy of 0.02% of Reading.

### 2.3.2 Grounding

The case of the AN3100 is connected to the grounding pin on the three-wire AC mains receptacle. Additionally, the white binding post terminal on the front panel and pin 1 of the low voltage output on the rear panel are tied to this chassis ground. However, through the use of isolated power supplies and an electrostatically shielded power transformer, the DC output can be externally offset to voltages within ±500 volts of ground. Voltages referenced to the AC mains ground are attained by attaching the shorting link between the COM side of the output and the white binding post. Positive and negative output values should be selected by the (- 0 +) switch in preference to other arrangements of front panel shorting straps. Care should be exercised to avoid double grounding as might arise when both the front output and rear output voltages are tapped. These two outputs are not isolated from each other and incorrect grounding may cause the 100:1 voltage divider to become bypassed.

#### Grounding Practices

When the circuit to be driven by the AN3100 DC Voltage Standard has one end grounded to the AC mains ground, then the shorting link should be removed from the AN3100 to prevent ground loop currents from generating offset values contributing to erroneous DC voltages (see Figure 2-3).

When the circuit to be driven by the AN3100 DC Voltage Standard is not grounded to the AC Power Ground, then a connection of the low side to case ground is desirable. This recommendation is especially useful in noisy environments or whenever large AC voltages are present between the AN3100 case and the internal circuitry. The grounding connection is made to the AN3100 via the case ground binding post terminal. If the load may be grounded, then the connection of Figure 2-4 or 2-5 may be used. The hook-up without the shorting link is preferred.

When the load must remain DC-isolated from AC power ground, then the case-to-circuit AC voltage may be grounded effectively by a 0.1 μF capacitor between COM and case ground as shown in Figure 2-6.

#### Rear Panel Output Grounding

Whenever the rear output voltage is to be referenced to ground, no grounded load should be simultaneously applied at the front terminals. The discussion on grounding practices above can be applied to the 111.110 millivolt range. Rear connector pin 2 is analogous to OUT and pin 3 to COM; pin 1 is connected to case ground.

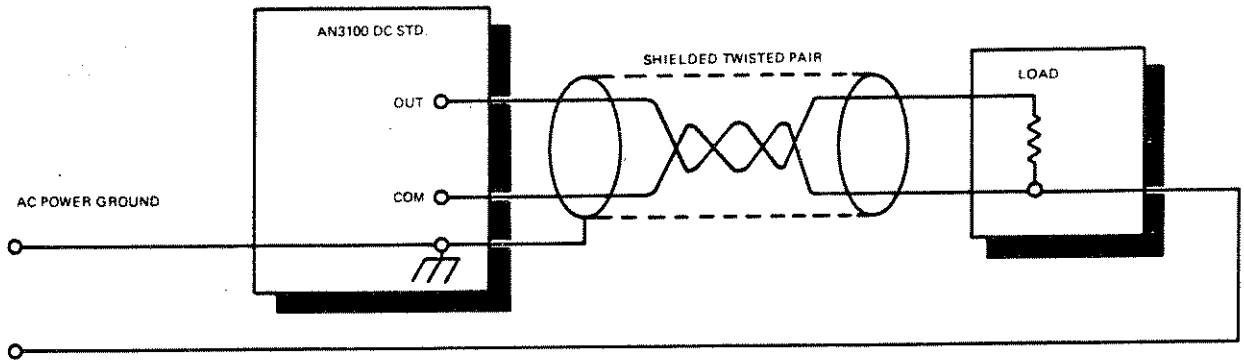

Figure 2.3

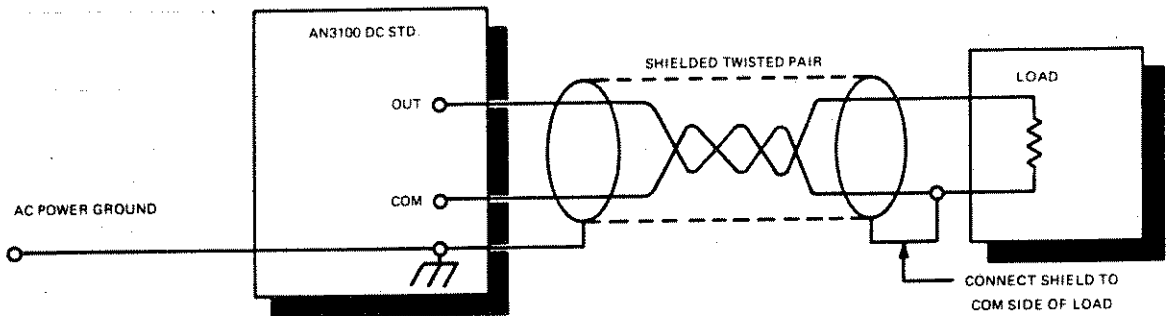

Figure 2.4

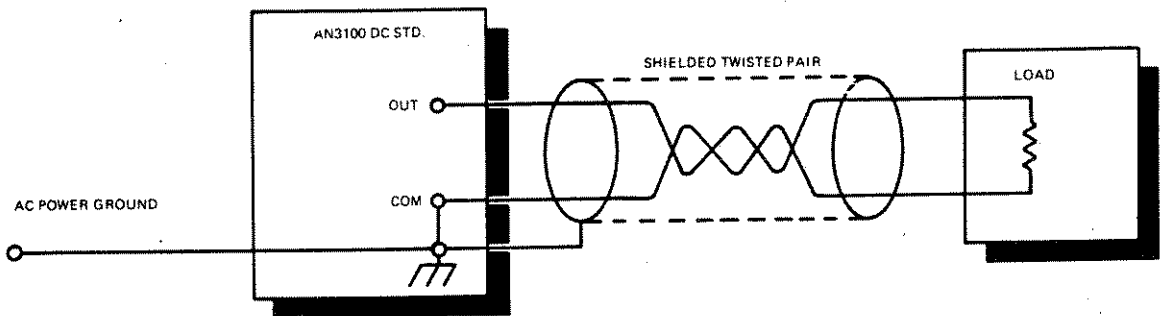

Figure 2.5

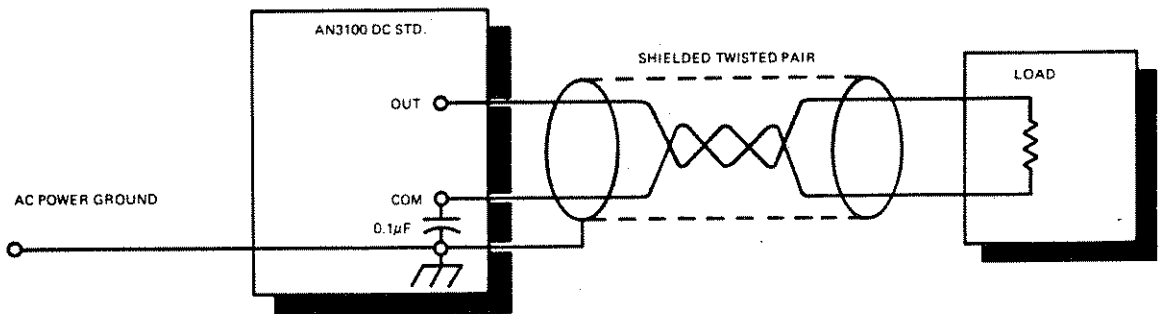

Figure 2.6

### 2.3.3 Output Impedance and Loading

#### Front Panel Output

The use of an operational amplifier and a transistorized power stage at the output of the AN3100 reduces the output impedance to a level of a few milliohms. The specification of 10 milliohms DC resistance is a worst case value which takes contact and terminal resistances and aging effects into account. For consideration, a quick Ohm's Law calculation will show that in the worst case, the internal voltage drop could result in a one least-significant-digit error under a 10 mA load current at 10.0000 dialed volts. Consequently, loading errors normally will be less than the least significant digit when the higher output range is being used.

#### Rear Panel Output

The internal voltage drops which result from drawing current from the rear output terminals may be precisely and accurately calculated using Ohm's Law. The voltage divider is configured to provide a Thevenin resistance of 100.00 ohms. Any current drawn from this terminal which exceeds  $0.01 \mu\text{A}$  will require a correction for this  $I \times R$  internal drop if the full five-digit precision is to be utilized.

### 2.3.4 Vernier Operation

When it is necessary to obtain a voltage of greater resolution than the 100-microvolt increment normally available in the decade switches, the built-in vernier control is engaged. This provides continuously variable values of voltage  $\pm 1 \text{ mV} \pm 15\%$  above and below the dialed setting ( $\pm 1$  digit on second least-significant-digit knob) at the main output.

To use the VERNIER adjustment,

- a) Dial the voltage within  $\pm 1 \text{ mV}$  of the expected final value.
- b) Pull out the VERNIER control knob on the front panel.
- c) Operate the VERNIER control until the desired value is obtained. (The display will read to the nearest 1 mV of the final value.)

Operation of the VERNIER control also affects the output from the AN3100 rear panel connector proportionately. The rear panel voltage variation is continuous over  $\pm 10$  microvolts range and is applied to the output value which is 1/100 the dialed voltage.



### 3. Principles of Operation

Tutorial information contained in this section of the manual is designed to permit a calibration technician or repairman to quickly acquaint himself with the full circuit schematic which appears in section 5.

Additionally, a more thorough understanding of the design of any instrument allows the user to apply the device to applications beyond those considered traditional.

#### 3.1 Calibrated Output

The AN3100 provides an output as selected by the five dials whenever it is in non-vernier operation. This calibrated output is displayed and delivered to the front binding post jacks. A calibrated output equal to 1/100th of the displayed value is simultaneously delivered to the rear MV OUTPUT connector.

While in vernier operation mode, the instrument is not calibrated to its full five dial precision. The three most-significant-digits are certain. The second least-significant-digit has an uncertainty of  $\pm 1$ , and the least most-significant-digit display should not be interpreted.

#### 3.2 Functional Block Diagrams

##### 3.2.1 AC Input Circuit

The fused AC mains are brought to the two primary windings via the input POWER switch, the 115/230V selector switch, and the power-line noise filter. The transformer itself is electrostatically shielded and grounded to the case and earth ground via the third wire of the AC line plug. Switch S7 parallels the primary windings for 115 volt operation and connects them in series for 230 volt use. The 115 volts used for the neon displays are tapped across one of these primary windings. The same is true for the lamp in the POWER switch which indicates the "power on" condition. Capacitor C22 and chokes L1 and L2 filter noise from the incoming AC current.

##### 3.2.2 Power Supplies

The transformer contains two secondary output windings, one for 17V AC, the other for 7V AC. Both are rated for 0.4 amp. The two windings are series connected to supply 24V AC for the reference oven. Two half-wave rectifiers are used to develop the  $\pm 15V$  DC.

The 17-volt secondary is half-wave rectified in dual circuits, heavily filtered by the 500  $\mu F$  capacitors, producing  $\pm 18V$  input to the regulating circuits. Regulation for the +15V supply is obtained through the action of Q8, whose control is developed by the voltage divider network of the reference diode CR12 and resistor R22. Regulation for the -15V supply is accomplished in a more sophisticated circuit including feedback amplifier A3, and control is exercised through transistor Q7. The more precisely regulated -15V supply is used to drive the reference Zener Diode CR11 via resistor R28, and provides the isolated reference ground for the AN3100 output.

##### 3.2.3 Servo Loop Voltage Reference

The stability of the AN3100 results from the servo loop circuitry surrounding the oven enclosed reference diode. This diode has been selected and aged prior to installation, and selected resistors are then matched to the zener's voltage characteristics. This  $6.3 \pm 0.1V$  zener performs two functions. First, it is the reference standard, and second, it is the -15V regulator reference. As for its reference function, it may be considered

a sink for a very precise and stable 100-microampere current. The use of a single diode to accomplish these two functions improves the circuit's performance as a precise and stable current sink.

Amplifier A3 regulates the current in the zener reference diode and provides protection against voltage fluctuations. This feature combined with matched wire-wound resistors enables the AN3100 to retain its accuracy over six-month calibration intervals.

The establishment of the 100-microampere sink current is a function of four closely matched components, namely, CR11, R1, R23, and R50. It is this current which generates the desired standard voltage as it passes through the precision decade resistance network. This voltage is then amplified in amplifier A1 and delivered to the output.

Other component functions in the reference circuit are:

- |          |                         |
|----------|-------------------------|
| C18      | Amplifier stabilization |
| C19, R23 | Amplifier stabilization |
| C27      | Loop stabilization      |

### 3.2.4 Block Diagrams

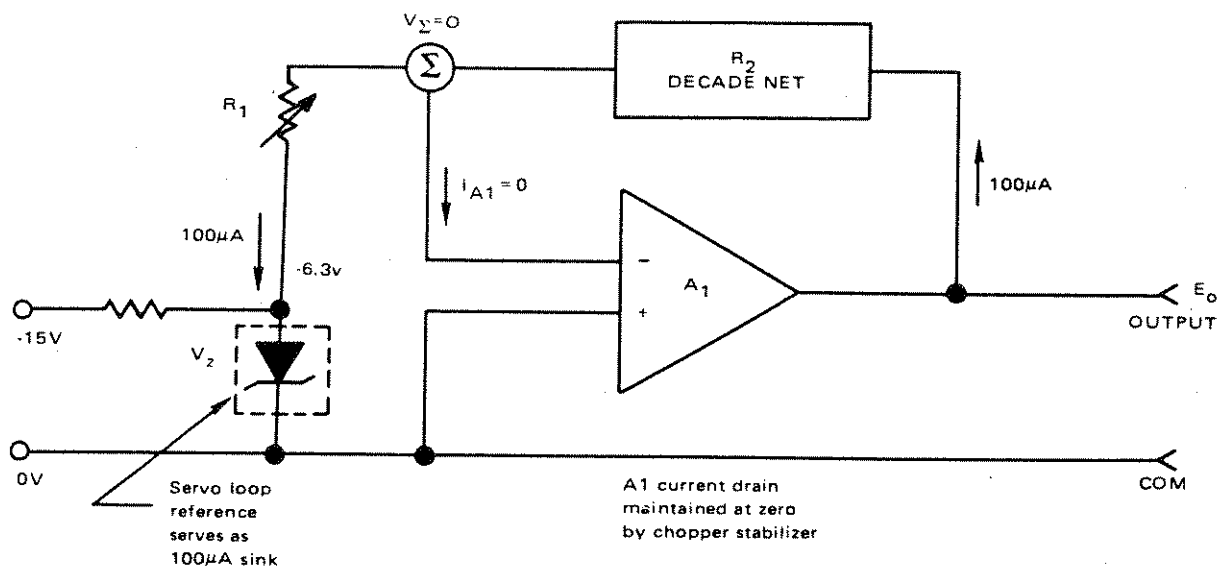

Figure 3.2.4.1 Reference Voltage Generation

The stability and accuracy of the Model 3100 Voltage Standard derive from the use of a chopper-stabilized, ultra-high-gain operational amplifier, with a precisely calibrated five-decade resistive feedback selector for regulation of the DC output voltage. See Figure 3.2.4.1.

The chopper-stabilized amplifier functions as a simple operational inverter. Because of the high-gain negative feedback from its output to its input via  $R_2$ , the Summing Point ( $\Sigma$ ) is held at zero volts to an uncertainty of a few parts in  $10^8$ , and the output voltage  $E_o$  is therefore a simple function of the input voltage  $V_z$ .

The equation for voltage to the left of the summing point ( $\Sigma$ ) is:

$$\text{Eq. 1} \quad V_{\Sigma} = V_z + I_{R1} R_1 \quad \text{and}$$

This same voltage taken to the right of the summing point is:

$$\text{Eq. 2} \quad V_{\Sigma} = E_o - I_{R2} R_2$$

Solving both equations for the current terms yields:

$$\text{Eq. 3} \quad I_{R1} = \frac{V_{\Sigma} - V_z}{R_1}$$

$$\text{Eq. 4} \quad I_{R2} = \frac{E_o - V_{\Sigma}}{R_2}$$

These currents are equal because the current drawn by amplifier  $A_1$  is maintained at zero by the chopper stabilizer. Equating Equation 3 to Equation 4 yields:

$$\text{Eq. 5} \quad \frac{E_o - V_{\Sigma}}{R_2} = \frac{V_{\Sigma} - V_z}{R_1}$$

The second function of the chopper stabilizer is to maintain the voltage at the summing point at zero volts. Substituting:

$$\text{Eq. 6} \quad V_{\Sigma} = 0 \quad \text{into equation 5 yields:}$$

Eq. 7

$$E_o = -V_z \frac{R_2}{R_1}$$

In the Model 3100,  $V_z$  is a fixed DC Voltage of extremely high stability, established by an oven-calibrated, highly compensated, selected, aged, and "pedigreed" zener-diode reference source. The effective temperature coefficient of the oven/zener combination is so low, and the time stability of the zener diode is so high, that the major uncertainty in the output voltage,  $E_o$ , is determined by the ratio of  $R_2$  to  $R_1$ .

The trimming portion of  $R_1$  is initially adjusted to draw a steady current of precisely 100 microamperes from the summing point; the amplifier holds the summing point at zero by adjusting its output voltage to supply the identical current through  $R_2$ . Since  $E_o = I_{R2} R_2$ , and  $I_{R2}$  is constant at 100 microamperes,

the output voltage  $E_o$  of the amplifier is adjustable with an accuracy, and a resolution, limited only by the accuracy and resolution of the feedback resistor  $R_2$  (which in the AN3100 is a five-decade resistance adjustable in one-ohm steps from 0 to 111,110 ohms). The ratio  $R_2/R_1$  is stable to 20 ppm/year, and the linearity of setting of  $R_2$  is well within 25 ppm/year.

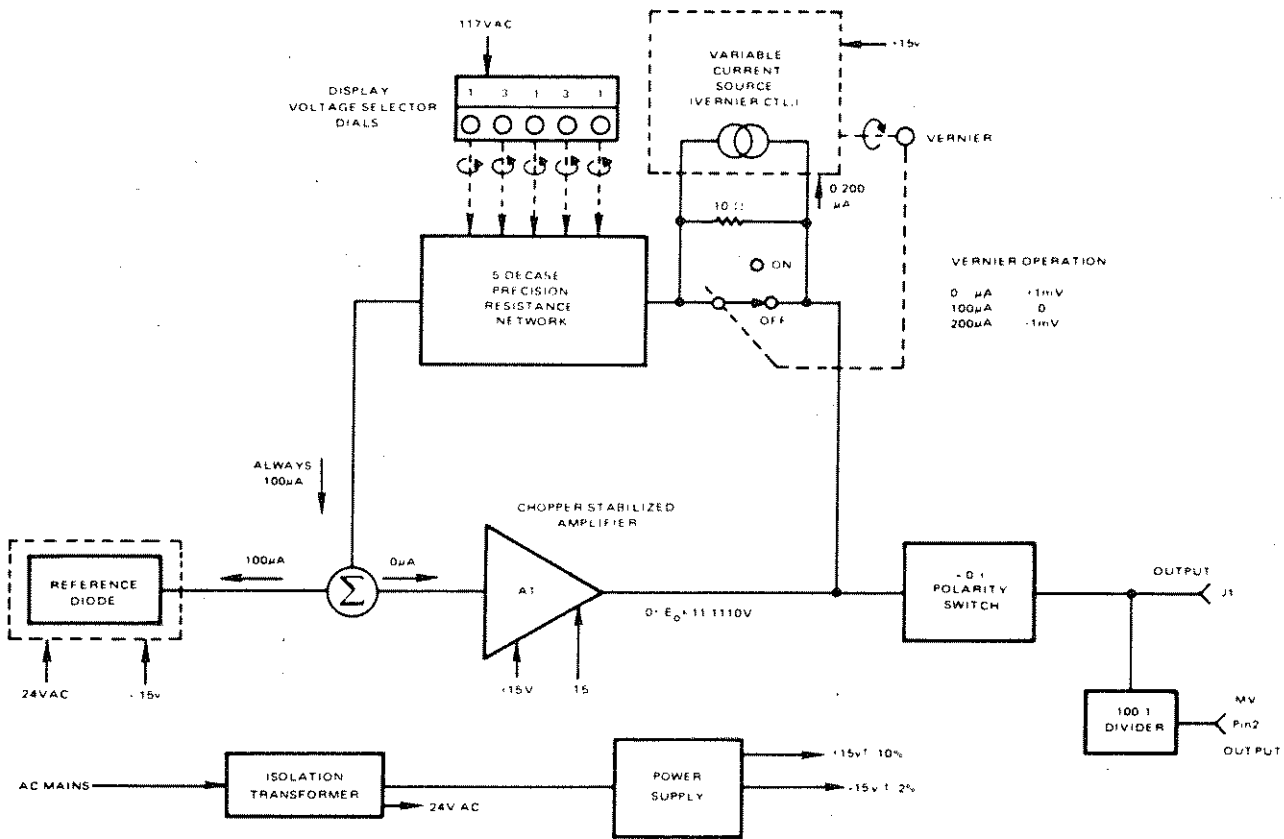

Figure 3.2.4.2 Simplified Block Diagram

### 3.2.5 Vernier Control

For applications in which extreme resolution (narrow-range) may be required—for example, when the AN3100 is employed to measure an unknown voltage by matching, with the aid of a high-sensitive external null detector—the desired setting may lie somewhere between two of the smallest digital settings of the instrument. For this purpose, a continuously variable  $\pm 1$  mV vernier adjustment has been incorporated, as indicated in Figure 3.2.4.2. For routine operation, the variable current generator and the 10-ohm resistor are shorted by switch contacts. When vernier adjustability is required, the vernier control knob on the front panel is pulled outward; this unshorts the 10-ohm resistor, placing it in series with the feedback loop. The variable current source is adjustable from 0 to 200 microamperes, this producing, in conjunction with the 10-ohm resistor, a voltage variation from -1 to +1 millivolt, and an equal variation in the nominal value of the output voltage  $E_o$  ( $\pm 10 \mu\text{V}$  in the auxiliary output voltage).

### 3.2.6 Chopper Stabilized Amplifier

The function of amplifier A1 is to provide unity voltage amplification of the precision signal voltage developed across the decade resistor network. It must perform this task without drawing any current away from the 100  $\mu$ A sink previously discussed. It is therefore of prime importance that the possibilities of offset voltage drift (and consequent current changes) be reduced to values well below those which would impair instrument accuracy. The input of amplifier A1 (inverting input pin 2) is kept at approximately zero volts. Any change from this value and signal ground is sensed by the high gain amplifier in the chopper circuit and delivered back as a differential (correction) voltage at pin 3 of amplifier A1.

The chopper circuit is comprised of these primary components:

Q3, Q4	Multivibrator of approximately 200-300 Hz (clean square wave)
Q1	Input synchronous switch, modulator (Mosfet)
Q2	Output synchronous switch, demodulator (bipolar)
R32, C5, CR3	Output conditioning circuit
A2	High gain ( $A_v > 2000$ ) operational amplifier
R58	Loop gain
C8, R34, C10	Stabilization

### 3.2.7 Output Circuit

The polarity of  $E_o$  presented at J1 (red binding post) and pin 2 of MV OUTPUT is selected by the (- 0 +) switch. This three-position polarity-reversing switch may serve as a standby switch when left in the center position or may be used to provide step functions of preselected values of either polarity.

The specified output current of 50 milliamperes applies only when the AN3100 is used as a source. The current sinking capability of the circuit is approximately 3 milliamperes, but may be increased by preloading the output.

Rear panel output is tapped directly from the front binding post terminals. Resistor R17 (10,000  $\Omega$ ) is matched to resistor R18 (101.01 $\Omega$ ) to provide division of  $E_o$  by a precise factor of 100. The Thevenin equivalent resistance at this output is also precisely 100.00 $\Omega$ . The result is an output voltage variable in discrete one-microvolt steps over a range of 0 to 111.1110 millivolts. Engagement of the vernier allows finer resolution, giving  $\pm 10 \mu$ V variations relative to any setting.



## 4. Maintenance

The AN3100 is designed for maintenance-free operation. Its solid-state circuitry is designed to dissipate very little heat, thereby reducing failures from that common source. Mechanical maintenance has also been minimized. There are no blowers or air filters to service and all that is required is cosmetic maintenance. Cleaning of the front bezel and display window should be accomplished without solvents as these may adversely affect the plexiglas display window.

Normal maintenance checks should assure the efficacy of the AC plug to case ground wire. This wire serves a safety function in addition to the ground referencing function for output signals (at operator's discretion).

Analogic maintains an in-house reference standards laboratory which will perform recalibration and other maintenance services on Analogic instruments which are returned to the Analogic factory. Such services are performed on a charge basis unless, of course, they are performed under the conditions of the warranty.

### 4.1 Recalibration

The recommended recalibration interval is six months. The unit may be returned to Analogic for recalibration, or it can be recalibrated in any standards laboratory with the following equipment (combined errors less than  $\pm 0.001\%$ ) or equivalent:

- |                     |                                          |
|---------------------|------------------------------------------|
| 1. Galvanometer     | Julie Research Laboratories type ND106   |
| 2. Potentiometer    | Julie Research Laboratories type PVS1000 |
| 3. Voltage Divider  | Julie Research Laboratories type VD106   |
| 4. Primary Standard | Julie Research Laboratories type SCO106  |

Calibration should be made at  $23^{\circ}\text{C}$  after the unit has been allowed to warm up for approximately one hour. Calibration potentiometer R28 is accessible after removing the four retaining screws and the bottom cover.

1. Set all decade switches to zero, polarity to +, and push in the Vernier knob. Measure the output with the Galvanometer. Zero offset, for which there is no adjustment, should be less than  $50\ \mu\text{V}$ . Disconnect the Galvanometer.
2. Set the decade switches to  $+10.0000\text{V}$  and set the calibration standards to measure  $+10.0000\text{V}$ . Adjust potentiometer R28 until the AN3100 DC Voltage Standard agrees with the calibration standards.
3. Set the decade switches for  $+1.0000\text{V}$  and set the calibration standards to measure  $+1.0000\text{V}$ . Check that the unit agrees with the calibration standards to within  $\pm 100\ \mu\text{V}$  ( $\pm 0.005\% \pm 50\ \mu\text{V}$ ).

### 4.2 Field Maintenance

Periodic maintenance other than recalibration and cleaning is not required. Should the performance of the instrument become suspect, the repair technician should be able to perform the checks diagrammed in Figure 4.2.1. Minimum test instrumentation will include a simple VOM, a simple-low frequency oscilloscope, and a  $200\ \Omega$  resistor for loading. More intense troubleshooting and recalibration will require the NBS traceable instruments mentioned under "4.1 Recalibration." Additionally, a five-dial Wheatstone Bridge is a valuable instrument if the problem is in the category of nonlinearity.









HA 157-1  
NTE 938

X3014

5.2 Parts List

Schematic Designation

Description

Amplifiers  
A1,A3  
A2

Operational Amplifier LM307  
Operational Amplifier LM301A

→ 14-420 307y \$100  
NONE

Capacitors

Schematic Desig.	Description	Schematic Desig.	Description
C1	0.1μF 10% Polycarb	C15	0.01μF Disc Ceramic
C2	0.33μF 10% Polycarb	C16,C17	6.8μF 35V Tantalum
C5	15μF 10V Tantalum	C20,C21	0.01μF Disc Ceramic
C6	0.1μF 10% Polycarb	C22	0.005μF 1.6kV Disc Ceramic
C7	150pF 5% Dipped Mica	C24	6.8μF 35V Tantalum
C8	3pF 5% Dipped Mica	C25	0.01μF Disc Ceramic
C9	6.8μF 35V Tantalum	C26	6.8μF 35V Tantalum
C11,C12	0.1μF 10% Mylar	C27	330pF 5% Dipped Mica
C13,C14	500μF 50V Electrolytic	C28	0.01μF Disc Ceramic
		C29	6.8μF 35V Tantalum

Resistors

R1	62K	Resistors R1 through R21 must be installed as a matched set. Order by Analogic Part A8-1047 See Note for R1	R27	Potentiometer 1 K (see Switch S9 listing)
R2	50K		R28	200Ω Trim Resistor Electra Midland RJ 24 CW 201
R3A,3B	20K		R29	5.49K 1% 1/2 W 100 PPM T.C.
R4	10K		R30	100K 10% 1/4 W C.C.
R5	5K		R31,R32	499K 1% 1/2 W 100 PPM T.C.
R6A,6B	2K		R34	Jumper
R7	1K		R35	1M 10% 1/4 W C.C.
R8	500Ω		R36	1.8K 5% 1/4 W C.C.
R9A,9B	200Ω		R37	6.8K 10% 1/4 W C.C.
R10	100Ω		R38	18K 5% 1/4 W C.C.
R11	50Ω		R39	47K 5% 1/4 W C.C.
R12A,12B	20Ω		R40,R41	68K 5% 1/4 W C.C.
R13	10Ω		R42	4.7K 5% 1/4 W C.C.
R14	5Ω		R43	33.2Ω 1% 1/2 W 100 PPM T.C.
R15A,15B	2Ω	R44	1K 10% 1/4 W C.C.	
R16	1Ω	R45	2.05K 1% 1/2 W 100 PPM T.C.	
R17	10K	R46	13.3K 1% 1/2 W 100 PPM T.C.	
R18	101.01Ω	R47	390Ω 10% 1/4 W C.C.	
R19	1.15K	R48,R49	330Ω 10% 1/4 W C.C.	
R20	6.3K	R50	Factory Selected	
R21	8.7K	R51,52,53,54,55	47K 5% 1/4 W C.C.	
R22	5.6K	R56	100K 10% 1/4 W C.C.	
R24	10K	R57	1K 10% 1/4 W C.C.	
R25	6.19K	R58	4.7M 5% 1/4 W C.C.	
R26	10Ω			

**5. PARTS LIST AND SCHEMATIC DIAGRAM**





Schematic Designation	Description
Diodes  CR1,2,3,4,5,13,14,15 CR6,7,8,9,10 CR11 CR12	1N 4148 Rectifier Diode 1 amp. 100P.I.V. Reference Diode Analogic Part 14-130004 1N 966A Zener Diode
Fuse  F1	1/4 amp                      3AG
Inductors  L1,L2	Inductor, National Radio 220 $\mu$ H
Lamps  DS1,2,3,4,5	Neon Lamps                      A1C
Oven  HR1	Klixon Part Number S3T 1-2
Switches  S1,2,3,4,5 S6 S7 S8 S9	Switch Analogic Part 15-400002 Toggle Switch CKW7211SY-Z-GE Switchcraft 46256-LF Marco Oak Part 57-41682-26-A1G Potentiometer & Switch Assembly Analogic Part A8-1048
Transformers  T1	Power Transformer Analogic Part 15-151049
Transistors  Q1 Q2,3,4,5,9 Q6,Q7 Q8	Motorola MFE 3004 2N3906 2N 2219 2N 4918

