

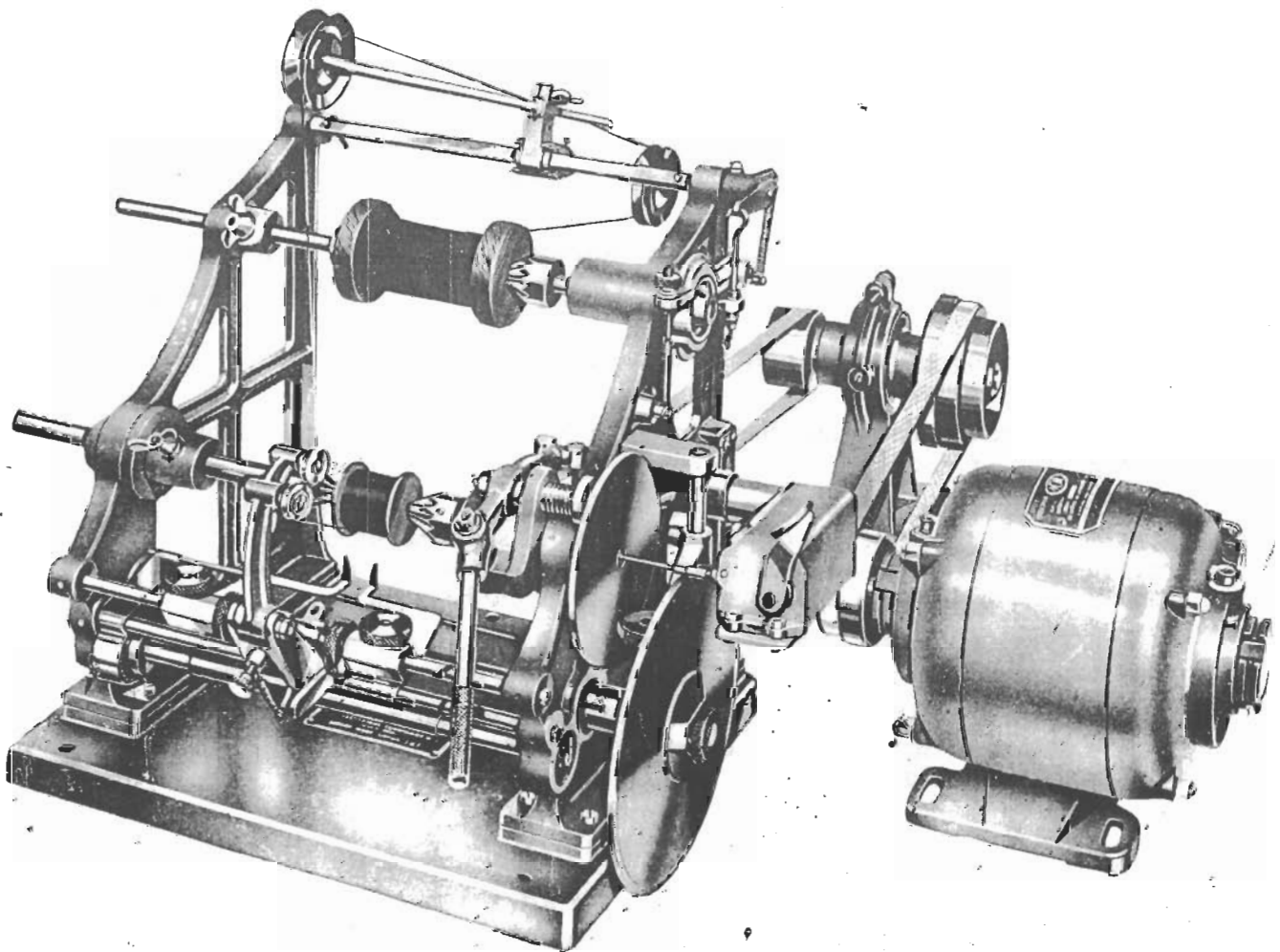

**"DOUGLAS"**  
**No. 1, No. 3 AND No. 3 EXTENDED**  
**COIL WINDING MACHINES**



---

**INSTALLATION • OPERATION • MAINTENANCE**  
**AND PARTS LIST**

---



“ DOUGLAS ”

No. 1, No. 3 AND No. 3 EXTENDED  
COIL WINDING MACHINES

---

INSTRUCTIONS FOR ORDERING SPARE PARTS

---

**W**HEN ordering spare parts the following suggestions, if observed, will save unnecessary delays caused by correspondence arising from inadequate descriptions.

1. Before ordering any spare parts reference should be made to the machine to ascertain its type. The type of machine should always be quoted on the order, and the part numbers and descriptions of the parts required listed ; these are shown on the plates.
2. If the desired part is not shown in the illustrations or indicated on the parts list, a complete description must be given, and where possible a pattern or sketch should be sent.
3. When ordering gears state number of teeth, width of face, diameter of bore and outside diameter.
4. When ordering pulleys, state diameter, width of face, size of bore and whether plain, flanged, or for Vee belts.

When improvements are made in the design of any machine and the parts are interchangeable, the latest type of part will always be supplied, unless the order states that the part must be the same as already fitted. In this case the serial number of the machine, date of purchase, and source of supply should be given.

The Company retain the right to alter any design without notification and guarantee against faulty workmanship only those parts manufactured by themselves.

Overseas users of Douglas Coil Winding Machines should address their enquiries to the Company's Agents in their country. Those in the United Kingdom should write direct to the address below.

**AVO LIMITED**

AVOCET HOUSE, 92-96, VAUXHALL BRIDGE ROAD, LONDON, S.W.1

*Telephone : Victoria 3404 (9 lines)*

Contractors to the ADMIRALTY, WAR OFFICE,  
AIR MINISTRY, POST OFFICE, MINISTRY OF  
SUPPLY, CROWN AGENTS for the COLONIES,  
and ELECTRICAL and TELEPHONE MANUFACTURERS throughout the World.



# MANUAL OF INSTALLATION, OPERATION AND MAINTENANCE

**THIS** instruction and spare parts manual is intended to cover all types of "DOUGLAS" No. 1 and No. 3 Coil Winding Machines.

## — INDEX —

	PAGE
WINDING CAPACITY ... ..	4
INSTALLING "DOUGLAS" NO. 1 MACHINE ... ..	4
INSTALLING "DOUGLAS" NO. 3 AND NO. 3 EXTENDED BASE MACHINE ... ..	4
HEADSTOCK SPINDLE SPEEDS ... ..	5
SETTING UP MACHINES ... ..	5
REVOLUTION COUNTER ... ..	7
INTERLEAVING THE COILS ... ..	7
MAINTENANCE ... ..	7
WIRE TENSION CHARTS ... ..	9

### LIST OF PLATES

"DOUGLAS" NO. 1 MACHINE—PLATE 1 ... ..	11
"DOUGLAS" NO. 3 MACHINE—PLATE 2 ... ..	13
MACHINE DETAILS—PLATE 3 ... ..	15
"DOUGLAS" NO. 3 EXTENDED BASE—PLATE 4 ... ..	16
LEVER RE-SET TYPE COUNTER—PLATE 5 ... ..	17
BENCH LAYOUT—PLATE 6 ... ..	18

"DOUGLAS" COIL



WINDING MACHINES

## THE "DOUGLAS" No. 1, No. 3 AND No. 3 EXTENDED BASE MACHINES

### WINDING CAPACITY

The winding capacity of both the "DOUGLAS" No. 1 and No. 3 Machines is similar and coils of round, square or rectangular section can be wound. The dimensions must be within the following limits:  $\frac{1}{8}$ " (3.2 mm.) to 5" (127 mm.) in length and up to  $4\frac{1}{4}$ " (108 mm.) diameter or diagonal. Coils with or without cheeks can be wound.

The "DOUGLAS" No. 3 Extended Base Machine will handle coils similar to the above

but up to 12" (305 mm.) in length.

### RANGE OF WIRE

Gauges of wire from 47 s.w.g. (0.002"—0.05 mm.) to 25 s.w.g. (0.02"—0.5 mm.) can be wound on all the three types of Machine, and care should be taken to see that the Wire Supply Reels comply with British Standards Institute Specification No. 1489, Table 2, (an extract from this Table appears on Page 8), since reels having an excessive gross weight cannot be adequately controlled.

NOTE: IN ADDITION TO THE THREE MACHINES ALREADY MENTIONED THE "DOUGLAS" NO. 1 IS ALSO AVAILABLE ON AN EXTENDED BASE AND HAS EXACTLY THE SAME WINDING CAPACITY AS THE "DOUGLAS" NO. 3 EXTENDED BASE MACHINE.

## INSTALLING THE MACHINES

### "DOUGLAS" No. 1 MACHINE

The "DOUGLAS" No. 1 Coil Winding Machine, being hand powered, requires no extra equipment when coils within its range are wound, and it is despatched from the Works ready for use. The parts supplied with the Machine include a Revolution Counter mounted on a Bracket, five spare Rubber Rings for Friction Drive Pulley, a Driving Dog which may be used as an alternative to the Fluted Cone and a Hexagon Wrench for adjusting the small Grub Screws, e.g. that used in the Fluted Cone, etc. To facilitate transit the Long and Short Wire Guide Pulley Arms are removed from the front and back Pulley Arm Blocks and must be re-positioned as follows. The Long Pulley Arm should be placed in the front Pulley Arm Block and the Short Pulley Arm in the back Pulley Arm Block. When choosing a site for the Machine sufficient space should be allowed for a soldering iron, materials and finished work.

The Machine should be secured to the front of the bench with three  $\frac{1}{4}$ " (6.35 mm.) diameter bolts or stout wood screws. The shaft of the Revolution Counter mounted on the Bracket is engaged in the Revolution Counter Coupling on the right hand side of the Machine and the Bracket may then be secured to the bench with two small wood screws; it is important to ensure that this Bracket does not foul any moving parts, and that the Coupling is not distorted in any way.

### "DOUGLAS" No. 3 AND No. 3 EXTENDED BASE MACHINES

These Coil Winding Machines are very similar to the "DOUGLAS" No. 1, but are power driven. The manufacturers recommend a  $\frac{1}{4}$  h.p. motor having a speed of 1425 r.p.m. and a "DOUGLAS" Countershaft to drive the Machines. Both these items are usually purchased from the manufacturers along with the Machine.

The parts supplied with these Machines include one Long and one Short Driving Belt, five spare Rubber Rings for Friction Drive Pulley, a Driving Dog which may be used as an alternative to the Fluted Cone and a Hexagon Wrench for adjusting the small Grub Screws, e.g. that used in the Fluted Cone, etc. To facilitate transit the Belt Striking Handle and the Long and Short Wire Guide Pulley Arms are removed from their respective fixings and must be re-positioned as follows. The Belt Striking Handle is screwed into the swivel casting on the Power Head and the long Pulley Arm should be placed in the front Pulley Arm Block and the Short Pulley Arm in the back Pulley Arm Block.

When choosing a site for the Machines sufficient space should be allowed for a soldering iron, materials and finished work. The Machines should be set out as shown on the Bench Lay-Out Plan, Plate No. 6, as this arrangement uses the most economical bench space and, furthermore,

## "DOUGLAS" COIL WINDING MACHINES

allows for belt slackness to be taken up by the eccentric housing in the Countershaft.

The Machine should first be secured to the front of the bench and the Countershaft then placed in the position as shown on the Bench Lay-Out Plan. The distance of the Countershaft from the Machine may be correctly determined by placing the Long Cotton Belt over the fast and loose Pulleys on the Headstock of the Machine and the small Pulley on the Countershaft, care being taken to ensure that the eccentric housing in the Countershaft is set as shown in the side elevation of this on the Bench Lay-Out Plan. The position of the Motor may similarly be determined by placing the small cotton belt over the Motor and Countershaft Pulleys. It is essential to see that these Pulleys are in perfect alignment, before the Motor is finally secured to the bench.

### DIRECTION OF ROTATION OF THE MACHINES

It is important that the Headstock Spindle on all three types of Machines be rotated in an anti-clockwise direction. This means that when operating the "DOUGLAS" No. 1 Machine the handle is turned in a clockwise direction when viewed from the right hand end of the Machine. In the case of the "DOUGLAS" No. 3 and "DOUGLAS" No. 3 Extended Base Machines, the motor shaft must be arranged to drive the fast and loose pulley on the Machine in an anti-clockwise direction, also when viewed from the right hand end of the Machines.

### HEADSTOCK SPINDLE SPEEDS FOR "DOUGLAS" No. 3 AND "DOUGLAS" No. 3 EXTENDED BASE MACHINES

The large and small three step Pulleys may be interchanged between the Motor and Countershaft and thus six headstock spindle speeds can be obtained from this combination. The table below shows the winding speeds available using a Motor having 1,425 r.p.m.

	R.P.M.		
Large Pulley on Motor	3900	2870	1980
Small Pulley on Countershaft			
Small Pulley on Motor	1270	875	650
Large Pulley on Countershaft			

The speeds chosen will, of course, depend upon the gauge of wire being used and the size of coil being wound; for example, a coil having a section whose sides have a ratio of 2:1 or more and wound with 25 s.w.g. (0.02"—0.5 mm.) is wound at the slowest speed, whereas a coil with a round section using wire of say 42 s.w.g. (0.004"—0.10 mm.) is wound at the fastest speed.

### BEFORE STARTING

Before any of these Machines are started the protective Lanoline should be removed and all oiling points together with the half nuts and the lead screws lubricated.

### GUARDING MOVING PARTS

In accordance with the Factory Regulations in force in the country where the Machines are being used, guards should be fitted over belts and other moving parts.

## SETTING UP THE MACHINE

### LOADING THE SUPPLY REEL

Having decided upon the coils to be wound the Wire Supply Reel is first loaded between the Back Centre and Fluted Cone on the Reel Carrier Brake SKETCH 'A'

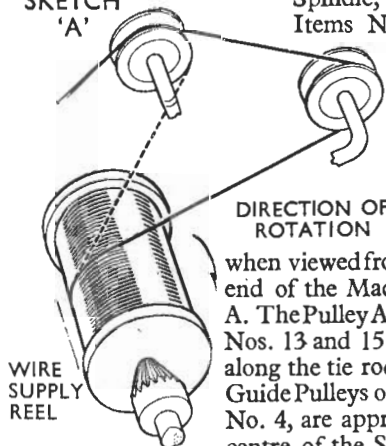

Spindle, see Plate No. 2, Items Nos. 11, and 92. When doing this care must be taken to ensure that the Supply Reel rotates in a clockwise direction when viewed from the right hand end of the Machine, see sketch A. The Pulley Arm Blocks, Items Nos. 13 and 15 are then moved along the tie rods until the Wire Guide Pulleys on the Arms, Item No. 4, are approximately in the centre of the Supply Reel.

If the gauge of wire being used is say between

30 s.w.g. (0.0124"—0.315 mm.) and 25 s.w.g. (0.02"—0.504 mm.), the wire is drawn from the Supply Reel and passed under the back Wire Guide Pulley and over the Front Wire Guide Pulley. If the gauge of wire varies from say 32 s.w.g. (0.01"—0.27 mm.) to 47 s.w.g. (0.002"—0.05 mm.) the wire is drawn over the front Wire Guide Pulley only. This is also shown in the sketch 'A', the dotted lines indicating the path for the finer gauge wires.

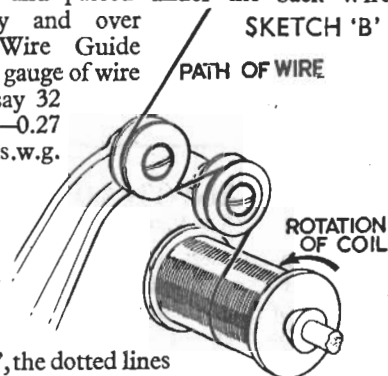

From the front Wire Guide Pulley the wire is passed over the Pulleys on the Wire Guide Arm, as shown in Sketch 'B'.

## "DOUGLAS" COIL WINDING MACHINES

### SETTING THE TENSION

The tension applied to the Wire Supply Reel is controlled by the adjustment of the Upper Brake Shoe, Item No. 26, Plate No. 2 on to the Reel Brake Pulley, Item No. 36. This Brake Shoe is fitted with a Light Tension Brake Spring, Item No. 30, for controlling the tension of fine wires. The Lower Brake Shoe, Item No. 33, is for controlling overrun of the supply reel and may also be adjusted to exert an initial tension in the wire. This is carried out by using the Heavy and Light Tension Springs, Items Nos. 24 and 25 as necessary and adjustment of the Brake Rod, Item No. 23; hence the following procedure may be adopted for setting the tension.

The nuts on the Supply Rod are loosened until

the Lower Brake Shoe falls clear of the Reel Brake Pulley. A weight equivalent to the recommended winding tension of the wire being used is suspended on the end of the wire, see Table on Page 9. The Upper Brake Shoe is then adjusted on to the Reel Brake Pulley by means of the Tension Adjusting Nut, Item No. 38, until the weight gradually falls. The Lower Brake Shoe is then brought into contact with the Reel Brake Pulley so that it just touches, this will set the correct overrun.

If the above method is carefully carried out only minor adjustments will be necessary following a trial run of the Machine.

A point to be noted is that the amount of overhang of the front Wire Guide Pulley will also slightly affect the initial tension in the wire.

### RATE OF TRAVERSE

The rate of traverse may now be determined. To do this the overall diameter of the wire being used is measured with a micrometer and an allowance to compensate for variation in wire diameter and space factor must be added to the reading, see Table below:—

This calculation will give the traverse in inches or millimetres as desired and is set on the Machine by positioning the Scale Plate Pointer, Item No. 56, Plate No. 3, against the same reading on the Scale. It should be noted that the graduations are marked in mils (this represents thousandths of an inch) and millimetres. This setting will give a very close approximation of the rate of traverse desired, final adjustment if necessary can be made after winding a layer of wire.

**TABLE SHOWING ALLOWANCE TO BE ADDED TO VARIOUS GAUGES OF WIRE**

WIRE GAUGE		APPROXIMATE ALLOWANCE	
S.W.G.	MM.	INCHES	MM.
50—46	0.025—0.06	0.0002	0.005
45—38	0.071—0.15	0.0004	0.010
37—30	0.17 —0.315	0.0006	0.015
29—25	0.345—0.50	0.0008	0.020

The allowances shown in the Table are only suggested and may have to be varied according to the type of wire and the coils being wound.

### SETTING LENGTH OF TRAVERSE

(See Plate No. 2)

The right and left hand Caliper Arms, Items Nos. 71 and 72 are provided for setting the length of traverse of the windings and may be utilised in the following way. Having positioned the coil former in the Headstock on the Machine, the Eye Bolt Nuts, Item No. 76 are loosened and the Caliper Sleeves, Item No. 75, are moved along the Guide Bar, Item 69, until the Caliper Arms can be moved up inside the cheeks of the coils or to a mark indicating the ends. For coils without cheeks the Caliper Arms may be positioned on a

mark on the former indicating the ends of the winding. The Caliper Arms are then lowered until they rest on the Arm Rest, Item 85. A trial run should then be made to ascertain the correctness of this setting and further adjustment, if necessary, may be done by turning the Traverse Adjusting Nuts, Item No. 78, in a clockwise or anti-clockwise direction as necessary.

**Note :** The setting of the Caliper Arms described above will only be approximately correct when the Traverse Adjusting Nuts are in the centre of the threaded portion on the Caliper Sleeves.

“DOUGLAS” COIL WINDING MACHINES

REVOLUTION COUNTER

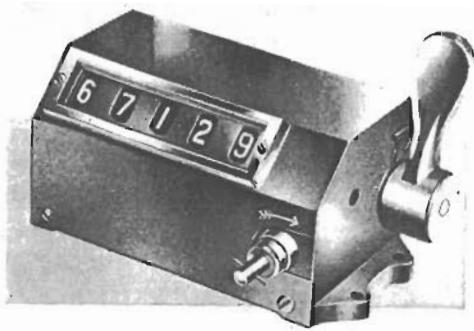

LEVER RE-SET TYPE REVOLUTION COUNTER

The Revolution Counter fitted to the “DOUGLAS” No. 1, “DOUGLAS” No. 3 and “DOUGLAS” No. 3 Extended Base Machines is a five figure lever re-set type, and is intended to be run in a CLOCKWISE direction. However, if necessary it can be used to count off subtracted turns from the coil, but this must be done by rotating the headstock of the Machine by hand only.

In addition to this illustration an exploded view of the Counter showing part numbers for spares appears on Page No. 17.

INTERLEAVING THE COILS

It must be appreciated that perfect layer winding cannot be obtained unless some medium of interleaving the layers of wire is employed. This may be paper, presspahn or cambric. The thickness of the material should be varied according

to the thickness of the wire being used, but care should be taken to see that it is of sufficient thickness to ensure that the wire does not fall into the interstices of the previous layer. A table showing these recommendations is given below.

INTER-LEAVING PAPER

*Recommended Paper Thickness in relationship to Wire Gauge*

INCHES		METRIC	
PAPER THICKNESS	WIRE GAUGE (S.W.G.)	PAPER THICKNESS (mm)	WIRE DIAMETER (mm)
0.0005”-0.00075”	47-42	0.012-0.018	0.05-0.10
0.001”	47-38	0.025	0.05-0.15
0.0015”	44-34	0.037	0.08-0.23
0.002”	38-30	0.05	0.15-0.32
0.003”	34-30	0.075	0.23-0.32
0.004”	30 and thicker	0.10	0.32 and thicker

MAINTENANCE

To ensure good coil winding it is necessary from time to time that the Machine be overhauled and it is considered that the following points will be very helpful when this is carried out.

1. When new long and short Lead Screws, Items Nos. 64 and 67 Plate No. 2. are fitted, it is essential that they should rotate freely, but without any measurable side play.
2. It is important when fitting new Half Nuts,

Item No. 20, Plate No. 3, that these have the edges of the thread well chamfered, as illustrated in the sketch, as it is important that they bed well down in the Lead Screws. Also to facilitate the removal of the Half Nuts from the Machine,

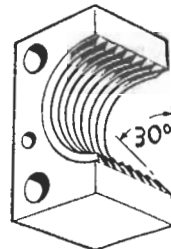

## "DOUGLAS" COIL WINDING MACHINES

a hole is provided in the left hand side frame and the method of loosening the screws is illustrated in the accompanying sketch.

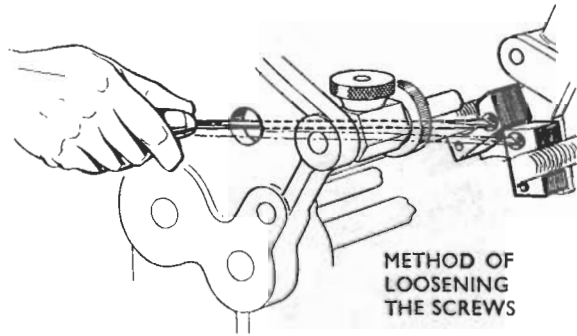

3. When a new Carriage is fitted it should be offered to the Machine at the extreme left hand end where the Lead Screws are undercut. This is to ensure that no damage is done to the threads.

4. When a new Trip Arm Stud, Item No. 19, Plate No. 3, is fitted, it must be arranged that the apex is 45° to the axis of the Lead Screws, as shown in the accompanying sketch. Care should be taken to see that this is well dimpled to take the neutralising pin to ensure that the Trip Stud does not turn in operation.

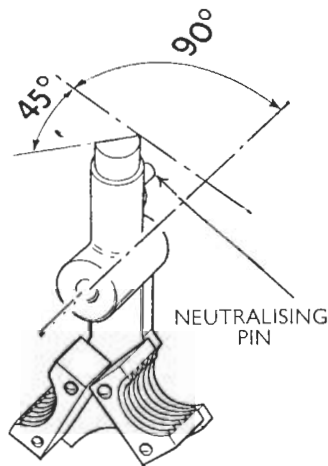

5. When new Ball Races and/or a new Brake Spindle, Items Nos. 17 and 35, Plate No. 2, are fitted, slight end play should be allowed in the Spindle approximating to 0.002" to 0.003" (0.05—0.075 mm.). This is to avoid the Spindle binding when a Supply Reel is in position.

On no account must the Machine be allowed to run for a long time without the necessary oiling points being lubricated, this particularly applies to the Lead Screws and Half Nuts which should be oiled (two or three drops) on alternate days with fine grade oil.

<b>WIRE SUPPLY REEL SIZES</b>									
DIAMETER OF WIRE			REEL FLANGE DIAMETER		DIAMETER OF WIRE			REEL FLANGE DIAMETER	
INCHES	METRIC mm.	S.W.G.	INS.	METRIC mm.	INCHES	METRIC mm.	S.W.G.	INS.	METRIC mm.
0-001	0-025	50	1 3/4"	44-45	0-010	0-254	33	3 3/4"	95-25
0-0012	0-03	49	1 3/4"	44-45	0-0108	0-256	32	3 3/4"	95-25
0-0016	0-04	48	1 3/4"	44-45	0-0116	0-280	31	3 3/4"	95-25
0-0020	0-05	47	2 1/4"	53-97	0-0124	0-306	30	4 1/2"	114-3
0-0024	0-06	46	2 1/4"	53-97	0-0136	0-331	29	4 1/2"	114-3
0-0028	0-07	45	2 1/4"	63-5	0-0148	0-358	28	4 1/2"	114-3
0-0032	0-081	44	2 1/4"	63-5	0-0164	0-407	27	4 1/2"	114-3
0-0036	0-098	43	2 1/4"	63-5	0-0180	0-457	26	4 1/2"	114-3
0-0040	0-102	42	2 1/2"	63-5	0-020	0-508	25	4 1/2"	114-3
0-0044	0-114	41	3"	76-2	0-022	0-559	24	4 1/2"	114-3
0-0048	0-122	40	3"	76-2	0-024	0-610	23	4 1/2"	114-3
0-0052	0-132	39	3"	76-2	0-028	0-711	22	6"	152-4
0-0060	0-152	38	3 3/4"	95-25	0-032	0-813	21	6"	152-4
0-0068	0-172	37	3 3/4"	95-25	0-036	0-914	20	6"	152-4
0-0076	0-194	36	3 3/4"	95-25	0-040	1-016	19	6"	152-4
0-0084	0-213	35	3 3/4"	95-25	0-048	1-219	18	6"	152-4
0-0092	0-234	34	3 3/4"	95-25					

Part of the above Table is reproduced by permission of THE BRITISH STANDARDS INSTITUTION, B.S. Specification 1489 (Table 2).



**TENSION CHART—Inches**

<i>Light Spring</i>		<i>Heavy Spring</i>	
GAUGE	WINDING WEIGHT	GAUGE	WINDING WEIGHT
47 s.w.g.	1 oz.	36 s.w.g.	9 ozs.
46 ..	1½ ozs.	35 ..	10 ..
45 ..	2 ..	34 ..	11½ ..
44 ..	2½ ..	33 ..	13 ..
43 ..	3 ..	32 ..	14 ..
42 ..	3½ ..	31 ..	15 ..
41 ..	4 ..	30 ..	16 ..
40 ..	5 ..	29 ..	18 ..
39 ..	5½ ..	28 ..	20 ..
38 ..	6½ ..	27 ..	23 ..
37 ..	8 ..	26 ..	25 ..
		25 ..	28 ..

**TENSION CHART—Metric**

<i>Light Spring</i>		<i>Heavy Spring</i>	
GAUGE	WINDING WEIGHT	GAUGE	WINDING WEIGHT
0.05	28 grams	0.19	255 grams
0.06	42 ..	0.21	283 ..
0.07	56 ..	0.23	326 ..
0.08	70 ..	0.25	369 ..
0.09	85 ..	0.27	397 ..
0.10	100 ..	0.29	425 ..
0.11	113 ..	0.32	454 ..
0.12	142 ..	0.35	510 ..
0.13	156 ..	0.375	566 ..
0.15	184 ..	0.416	652 ..
0.17	227 ..	0.457	709 ..
		0.508	794 ..

NOTE.—The winding weights shown in the tables are those specified by certain wire manufacturers and may have to be exceeded to obtain tight wound coils.

### Plate 1—Parts List

ITEM NO.	DESCRIPTION	PART NO.	NO. OFF	ITEM NO.	DESCRIPTION	PART NO.	NO. OFF
1	Gear Wheel (140 teeth)	20367/3	1	9	Revolution Counter	10217/4	1
2	Pin Securing Item 1	20339/22	1	10	Screws Securing Item 9	S.449	4
3	Driving Shaft Collar	13005/2	1	11	Nuts for Item 10	N.36	4
4	Screw Securing Item 3	AS.28	1	12	Pinion Gear (14 teeth)	12150/1	1
5	Driving Shaft	12151/1	1	13	Pin Securing Item 12	20339/19	1
6	Handle Complete	20371/A	1	14	Head Casting	20369/3	1
7	Screw Securing Item 6	AS.28	1	15	Screws Securing Item 14	S.245	4
8	Revolution Counter Bracket	20915/1	1	16	Headstock Driving Spindle	11882/1	1

FOR ALL OTHER ITEMS NOT SHOWN SEE PLATE 2.

# PLATE 1 DOUGLAS NO. 1 MACHINE

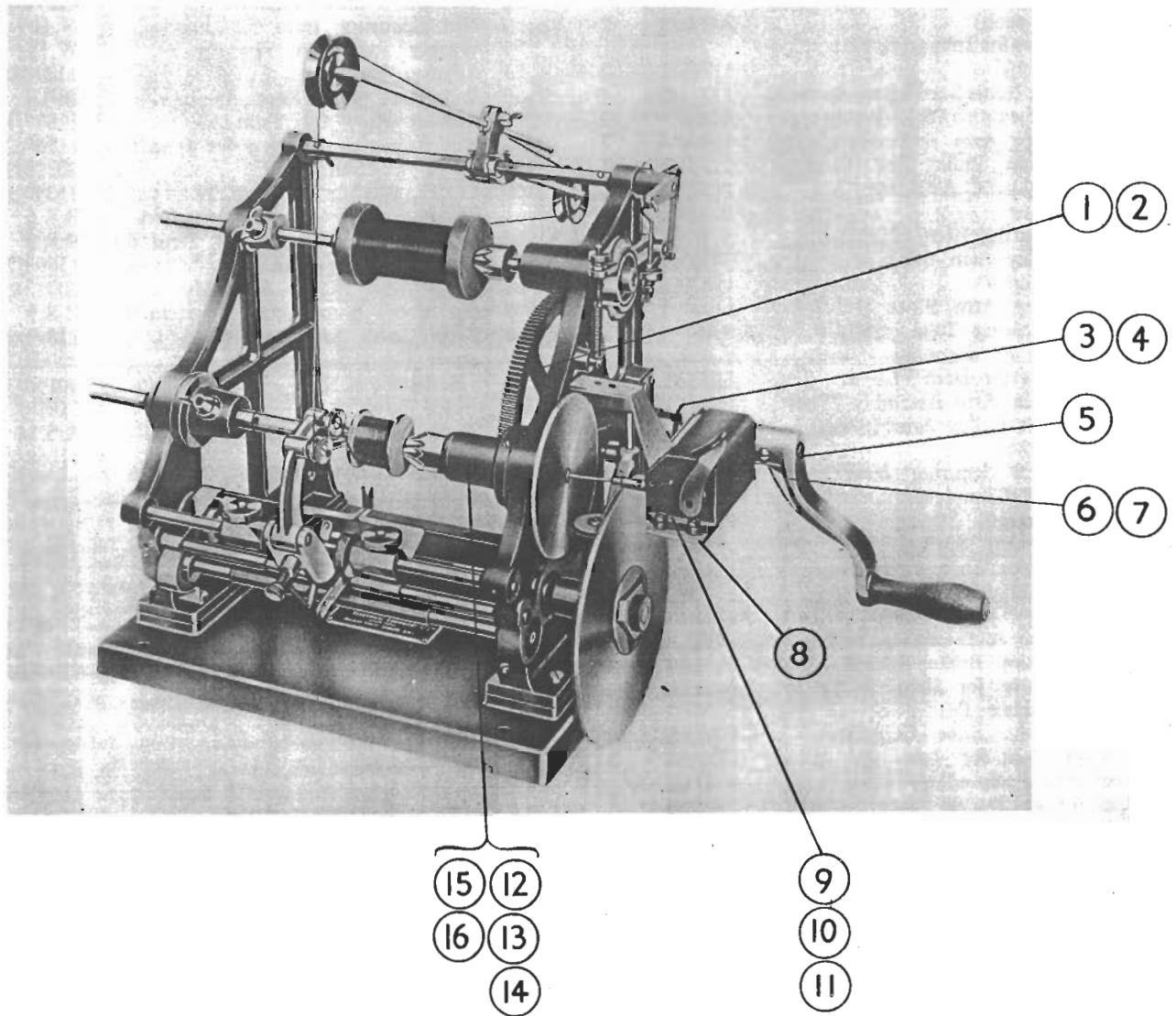

## Plate 2—Parts List

ITEM NO.	DESCRIPTION	PART NO.	NO. OFF	ITEM NO.	DESCRIPTION	PART NO.	NO. OFF
1	L.H. Side Frame and Centre Spindle Boss Assembly . . . . .	40430/A	1	48	Friction Pulley Bracket . . . . .	20303/3	1
2	Centre Spindle Boss . . . . .	20300/2	2	49	Revolution Counter Coupling . . . . .	11875/A	1
3	Bush . . . . .	11895/1	2	50	Small Friction Disc . . . . .	20299/3	1
4	Wire Guide Pulleys for Items 8 & 19 (one on each) . . . . .	20282/2	2	51	Screw Securing Item 50 . . . . .	S.201	1
5	Dust Covers for Items 8 & 19 (one on each) . . . . .	11775/2	2	52	Friction Pulley Spindle . . . . .	11876/2	1
6	Circlips for Items 8 & 19 (two on each)	11777/1	4	53	Nut Securing Item 52 . . . . .	N.41	1
7	Ball Races for Items 8 & 19 (one on each)	B.R.4	2	54	Washer for Item 52 . . . . .	W.15	1
8	Wire Guide Arm Assembly (Long)	11900/A	1	55	Friction Pulley . . . . .	11878/2	1
9	Wire Guide Pulley Arm (Long)	11956/1	1	56	Ball Race for Item 55 . . . . .	B.R.4	1
10	Square Spindle Assembly . . . . .	11897/A	1	57	Rubber Ring for Item 55 . . . . .	11877/1	1
11	Fluted Cone . . . . .	10780/2	2	58	Nut Adjusting Tension for Item 59	11885/2	1
12	Screw Securing Item 11 . . . . .	A.S.23	2	59	Large Friction Disc . . . . .	20308/3	1
13	Front Pulley Arm Block . . . . .	20305/3	1	60	I.O.M. Washer for Item 59 . . . . .	11340/1	1
14	Winged Screw . . . . .	11870/B	1	61	Ball Race 1/2" dia. for Item 64 . . . . .	B.R.6	1
15	Back Pulley Arm Block . . . . .	11917/3	1	62	Ball Race 8 mm. dia. for Item 64	B.R.9	1
16	Screw Securing Item 15 . . . . .	S.461	1	63	Dust Cover for Item 62 . . . . .	11893/2	1
17	Ball Races for Item 35 . . . . .	B.R.9	2	64	Long Lead Screw Assembly . . . . .	20313/A	1
18	Dust Cover for Item 17 . . . . .	11871/2	1	65	Ball Races 8 mm. dia. for Item 69	B.R.9	2
19	Wire Guide Arm Assembly (Short)	11900/B	1	66	Dust Cover for Item 67 . . . . .	11893/2	2
20	Wire Guide Pulley Arm (Short) . . . . .	11956/2	1	67	Short Lead Screw . . . . .	20089/1	1
21	Brake Rocker . . . . .	11869/3	1	68	Side Frame R.H. . . . .	40158/3	1
22	Grub Screw Securing Item 21 . . . . .	A.S.28	1	69	Guide Bars . . . . .	11889/1	2
23	Brake Rod Complete . . . . .	11910/A	1	70	Screw Securing Item 69 . . . . .	A.S.24	4
24	Heavy Tension Spring . . . . .	11918/1	1	71	Caliper Arm R.H. . . . .	11868/2	1
25	Light Tension Spring . . . . .	11908/2	1	72	Caliper Arm L.H. . . . .	11868/4	1
26	Upper Brake Shoe Complete . . . . .	11912/A	1	73	Nuts Securing Items 71 & 72 . . . . .	S.452	4
27	Leather Pad for Item 26 . . . . .	11926/2	1	74	Washers for Item 73 . . . . .	W.16	4
28	Hinge Pin . . . . .	11916/1	1	75	Caliper Sleeve . . . . .	11886/2	2
29	Circlip for Item 28 . . . . .	11777/1	1	76	Eye Bolt Nut . . . . .	11888/2	2
30	Light Tension Brake Spring . . . . .	11914/1	1	77	Eye Bolt . . . . .	11887/2	2
31	Leather Strip for Item 30 . . . . .	11915/1	1	78	Transverse Adjusting Nuts . . . . .	11885/2	2
32	Spring Anchor Post . . . . .	11907/1	2	79	Base . . . . .	40160/3	1
33	Lower Brake Shoe Complete . . . . .	11925/A	1	80	Gear Guard . . . . .	11892/2	1
34	Leather Pad for Item 33 . . . . .	11926/1	1	81	Front Spur Wheel . . . . .	11891/1	1
35	Reel Brake Spindle . . . . .	11873/1	1	82	Pin Securing Item 81 . . . . .	R.27	1
36	Reel Brake Pulley . . . . .	11866/3	1	83	Rear Spur Wheel . . . . .	11939/1	1
37	Grub Screw Securing Item 36 . . . . .	A.S.23	1	84	Pin Securing Item 83 . . . . .	R.27	1
38	Tension Adjusting Nut for Item 26	10807/2	1	85	Arm Rest for Items 71 & 72 . . . . .	11890/1	1
39	Washer for Item 38 . . . . .	W.15	1	86	Long Back Centre Spindle . . . . .	10596/2	1
40	Adjusting Stud for Item 38 . . . . .	11755/2	1	87	Eye Bolt for Item 86 . . . . .	11867/2	1
41	Tension Spring for Upper Brake Shoe	11908/2	1	88	Wing Nut for Item 87 . . . . .	N.51	1
42	Revolution Counter Bracket Assembly	20374/2	1	89	Top Back Centre Spindle . . . . .	11899/1	1
43	Friction Pulley Spindle . . . . .	11919/1	1	90	Eye Bolt for Item 89 . . . . .	11894/2	1
44	Revolution Counter (Clockwise)	10217/4	1	91	Wing Nut for Item 90 . . . . .	N.51	1
45	Screws Securing Item 44 . . . . .	S.450	2	92	Cone Centre . . . . .	10595/A	2
46	Screws Securing Item 44 . . . . .	S.449	2	93	Top Stay Bar . . . . .	11898/2	1
47	Nuts for Item 46 . . . . .	N.22	2	94	Upper Brake Shoe Spring . . . . .	11872/1	1
				95	Short Driving Belt . . . . .	MISC.32	1
				96	Long Driving Belt . . . . .	MISC.33	1

# PLATE 2 DOUGLAS NO. 3 MACHINE

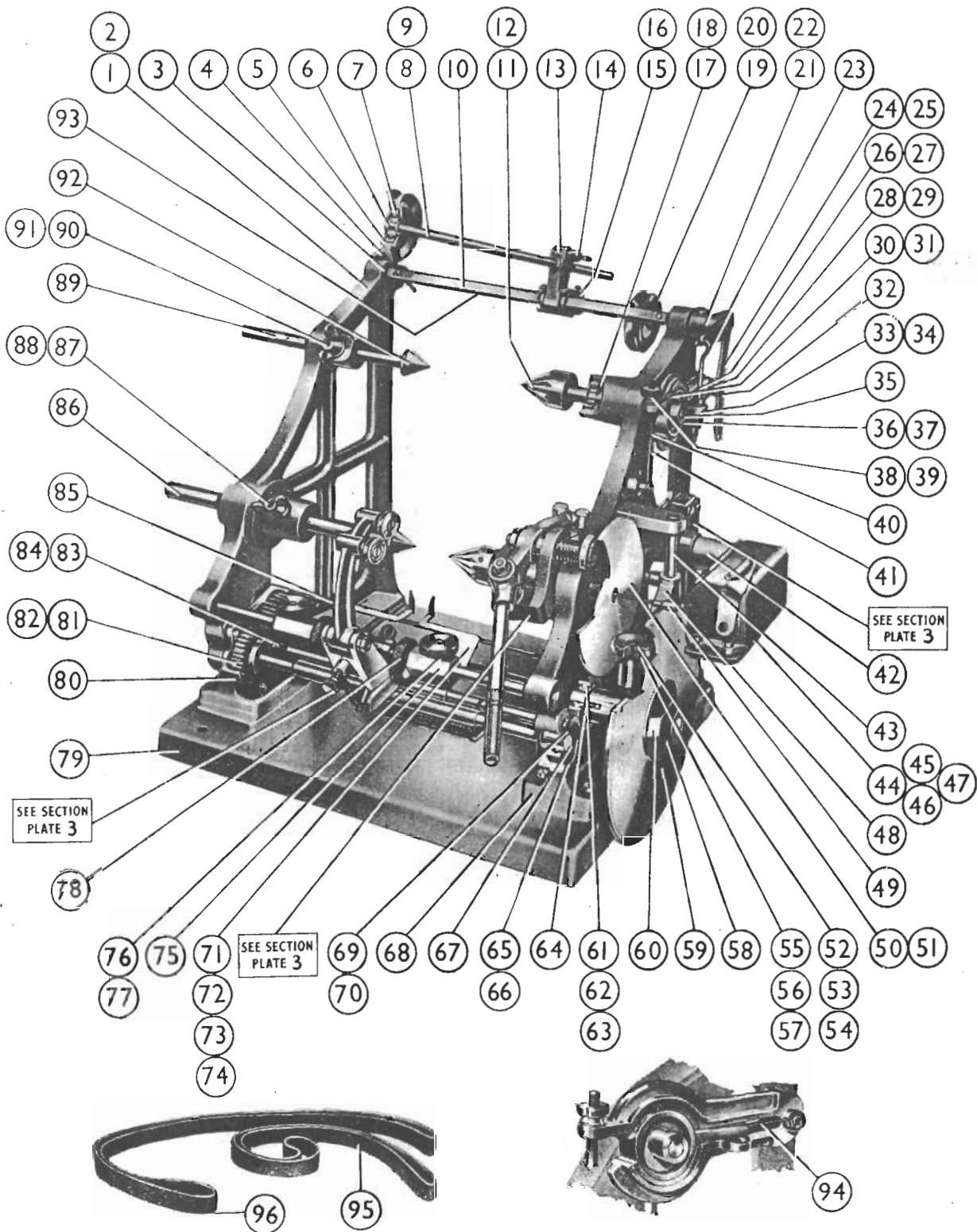

## Plate 3—Parts List

ITEM NO.	DESCRIPTION	PART NO.	NO. OFF	ITEM NO.	DESCRIPTION	PART NO.	NO. OFF
1	Wire Guide Arm Complete . . . . .	20317/A	1	32	Shoulder Screw for Item 1 . . . . .	11884/1	1
2	Wire Guide Arm . . . . .	20316/3	1	33	Lock Nuts for Item 32 . . . . .	N.40	2
3	Rear Wire Guide Pulley . . . . .	10571/2	1	34	Carriage Assembly complete with Long Guide Tube . . . . .	11949/B	1
4	Ball Race for Item 3 . . . . .	B.R.4	1	35	Brake Collars . . . . .	11881/2	2
5	Screw Securing Item 3 . . . . .	10568/1	1	36	Screws Securing Item 35 . . . . .	A.S.23	2
6	Front Wire Guide Pulley . . . . .	10569/2	1	37	Striker Arm Assembly	20310/A	1
7	Ball Race for Item 6 . . . . .	B.R.4	1	38	Spring for Item 39 . . . . .	11880/1	1
8	Screw Securing Item 6 . . . . .	10568/1	1	39	Brake Assembly Complete . . . . .	11879/A	1
9	Wire Guide Arm Complete (Vane type) . . . . .	20318/A	1	40	Leather for Item 39 . . . . .	11944/1	1
10	Leather Pad . . . . .	11902/1	1	41	Side Frame R.H. . . . .	40158/3	1
11	Glass Tube (Short) . . . . .	11904/1	1	42	Driving Pulley . . . . .	11694/2	1
12	Wire Guide Rod (Short) for Item 11 . . . . .	11906/2	1	43	Screw Securing Item 42 . . . . .	A.S.27	1
13	Wire Guide Rod (Long) for Item 14 . . . . .	11906/4	1	44	Loose Pulley (20 mm. Ball Race) . . . . .	B.R.2	1
14	Glass Tube (Long) . . . . .	11904/2	1	45	Ball Races for Item 46	B.R.9	2
15	Wire Guide Blades . . . . .	11905/2/4	1 pr.	46	Driving Spindle . . . . .	11882/1	1
16	Screw Securing Item 15 . . . . .	S.462	2	47	Power Winder Head Assembly . . . . .	20309/B	1
17	Wire Guide Arm (Vane type) . . . . .	20304/3	1	48	Washer for Item 50 . . . . .	W.15	1
18	Half Nut Arm Assembly . . . . .	11935/A	1	49	Friction Washer for Item 37 . . . . .	W.32	1
19	Trip Stud for Item 18 . . . . .	11937/1	1	50	Nut Retaining Item 53 . . . . .	N.41	1
20	Half Nuts (Pair R.H. & L.H.) . . . . .	11940/1/2	1 pr.	51	Driving Dog . . . . .	13004/1	1
21	Screws Securing Item 20 . . . . .	S.657	4	52	Screw Securing Item 51 . . . . .	A.S.24	1
22	Hinge Pin for Item 18 . . . . .	11938/1	1	53	Striker Arm Spindle	11903/1	1
23	Neutralising Lever . . . . .	11941/2	1	54	Screw Securing Item 53 . . . . .	A.S.23	1
24	Shoulder Screw Securing Item 23 . . . . .	11883/2	1	55	Pointer Link Screw (Bottom) . . . . .	11920/2	1
25	Trip Pin . . . . .	20339/5	1	56	Scale Plate Pointer . . . . .	11921/B	1
26	Top Bearing for Item 34 . . . . .	11934/2	1	57	Screw Securing Item 56 . . . . .	S.110	1
27	Spring for Item 28 . . . . .	11928/1	1	58	Friction Washer for Item 56 . . . . .	11927/1	1
28	Trip Arm with Point . . . . .	14133/A	1	59	Pointer Link . . . . .	11923/2	1
29	Trip Arm Point . . . . .	11933/2	1	60	Pointer Link Screw (Top) . . . . .	11920/4	1
30	Spring Anchor Post . . . . .	11930/1	1				
31	Adjusting Screw . . . . .	11753/4	1				

Note : Item 51 may be replaced by Fluted Cone, Item No. 11, see Plate No. 2.

# PLATE 3 MACHINE DETAILS

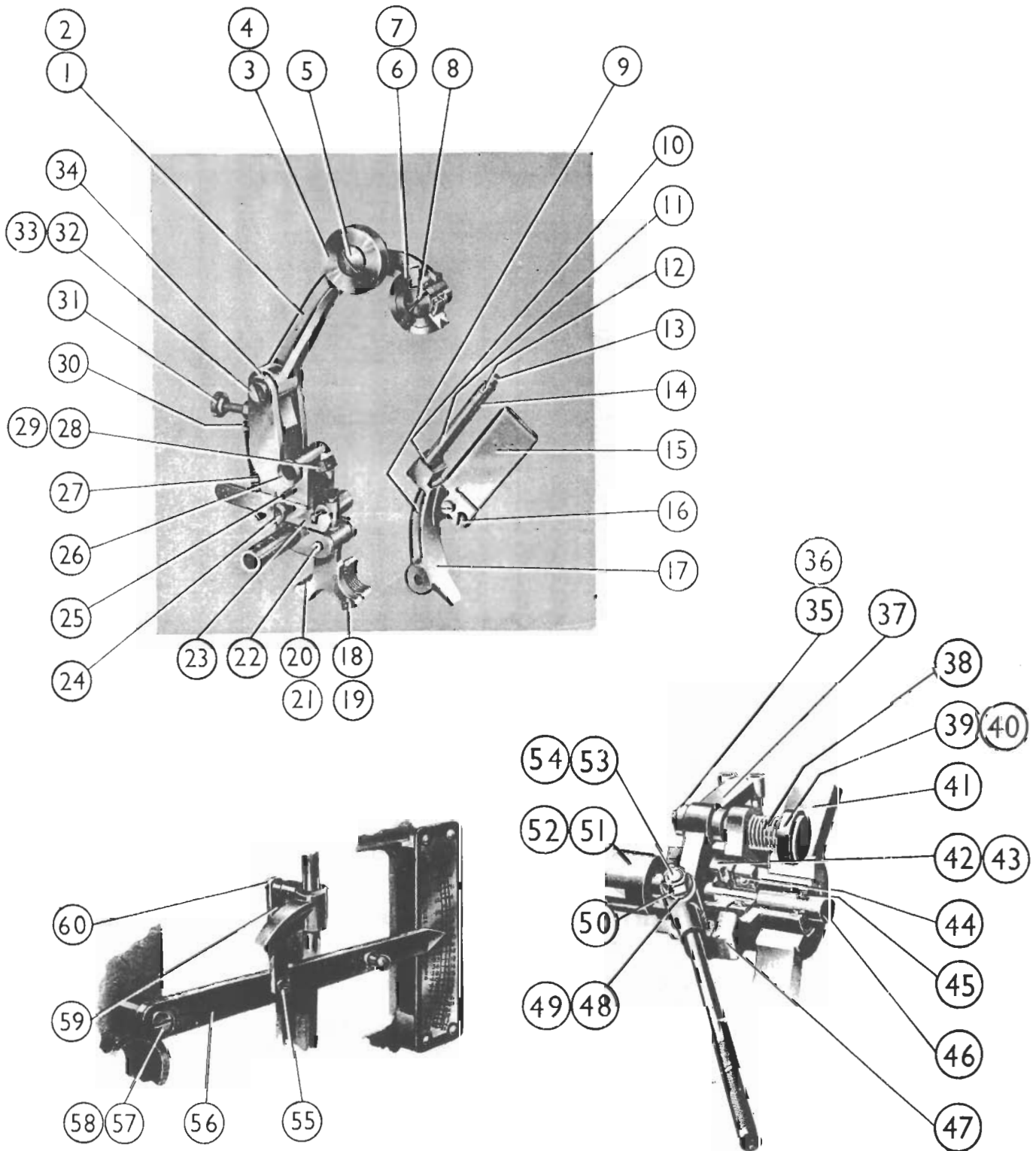

# PLATE 4 DOUGLAS NO. 3 EXTENDED

## BASE MACHINE

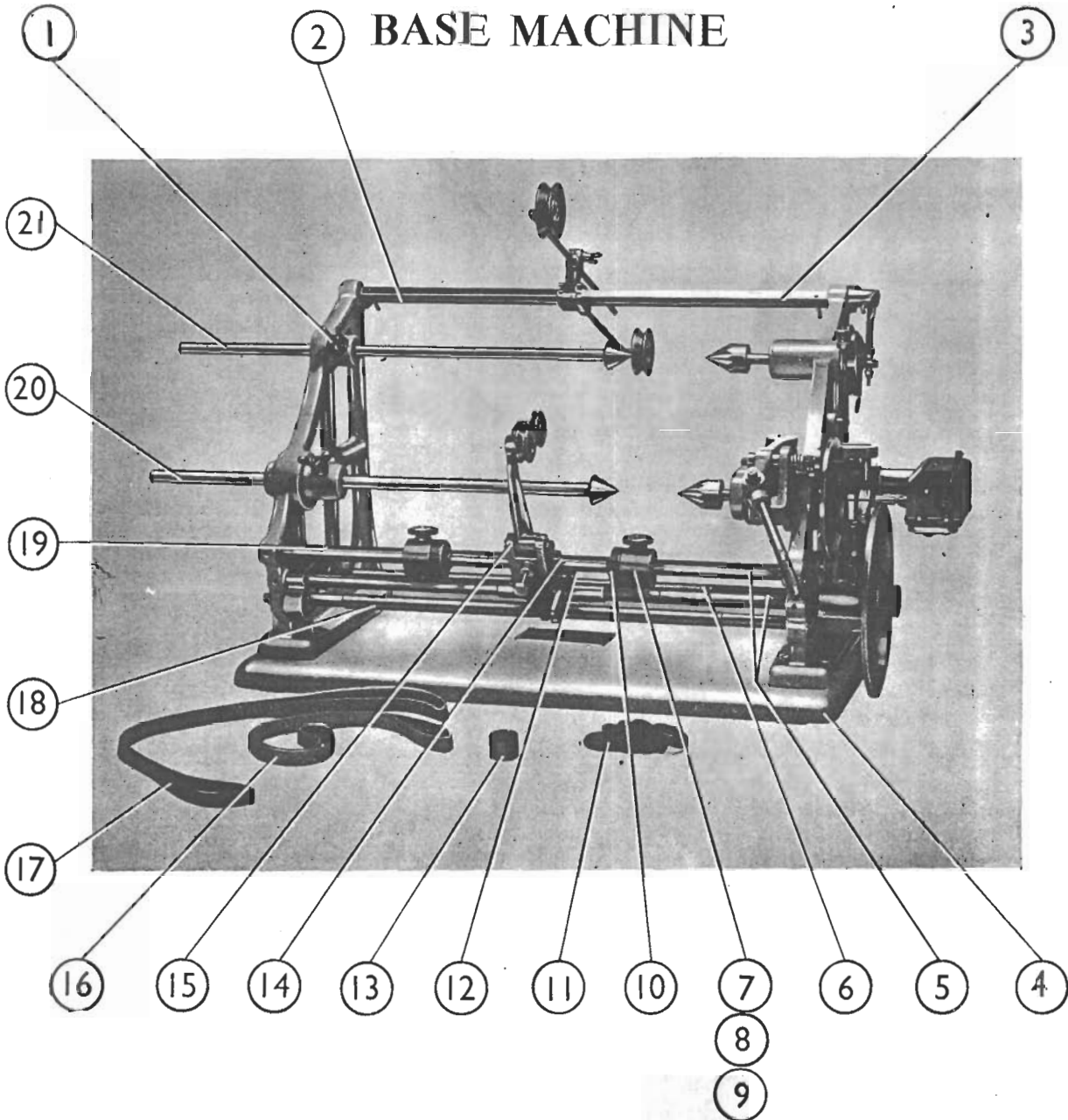

### Plate 4—Parts List

ITEM NO.	DESCRIPTION	PART NO.	NO. OFF	ITEM NO.	DESCRIPTION	PART NO.	NO. OFF
1	Eye Bolt for Item 21 . . . . .	11894/4	1	12	Trip Arm Pin . . . . .	20339/44	1
2	Top Stay Bar . . . . .	11898/4	1	13	Driving Dog . . . . .	13004/2	1
3	Square Spindle Assembly . . . . .	11897/B	1	14	Carriage Top Bearing . . . . .	14142/2	1
4	Base . . . . .	40241/3	1	15	Carriage and Tube Assembly . . . . .	14141/A	1
5	Guide Bars . . . . .	11889/2	2	16	Short Driving Belt . . . . .	MISC.32	1
6	Long Lead Screw Assembly . . . . .	20313/B	1	17	Long Driving Belt . . . . .	MISC.33	1
7	Caliper Stops . . . . .	14139/2	2	18	Short Lead Screw . . . . .	20089/2	1
8	Caliper Sleeve Eye Bolts . . . . .	14140/1	2	19	Arm Rest . . . . .	11890/2	1
9	Eye Bolt Nut . . . . .	11888/2	2	20	Bottom Back Centre Spindle . . . . .	10596/4	1
10	Split Nuts . . . . .	14138/2	2	21	Top Back Centre Spindle . . . . .	11899/2	1
11	Rubber Rings for Friction Drive Pulley . . . . .	11877/1	5				

FOR ALL OTHER ITEMS NOT SHOWN SEE PLATE 2.



# PLATE 5 LEVER RE-SET TYPE COUNTER

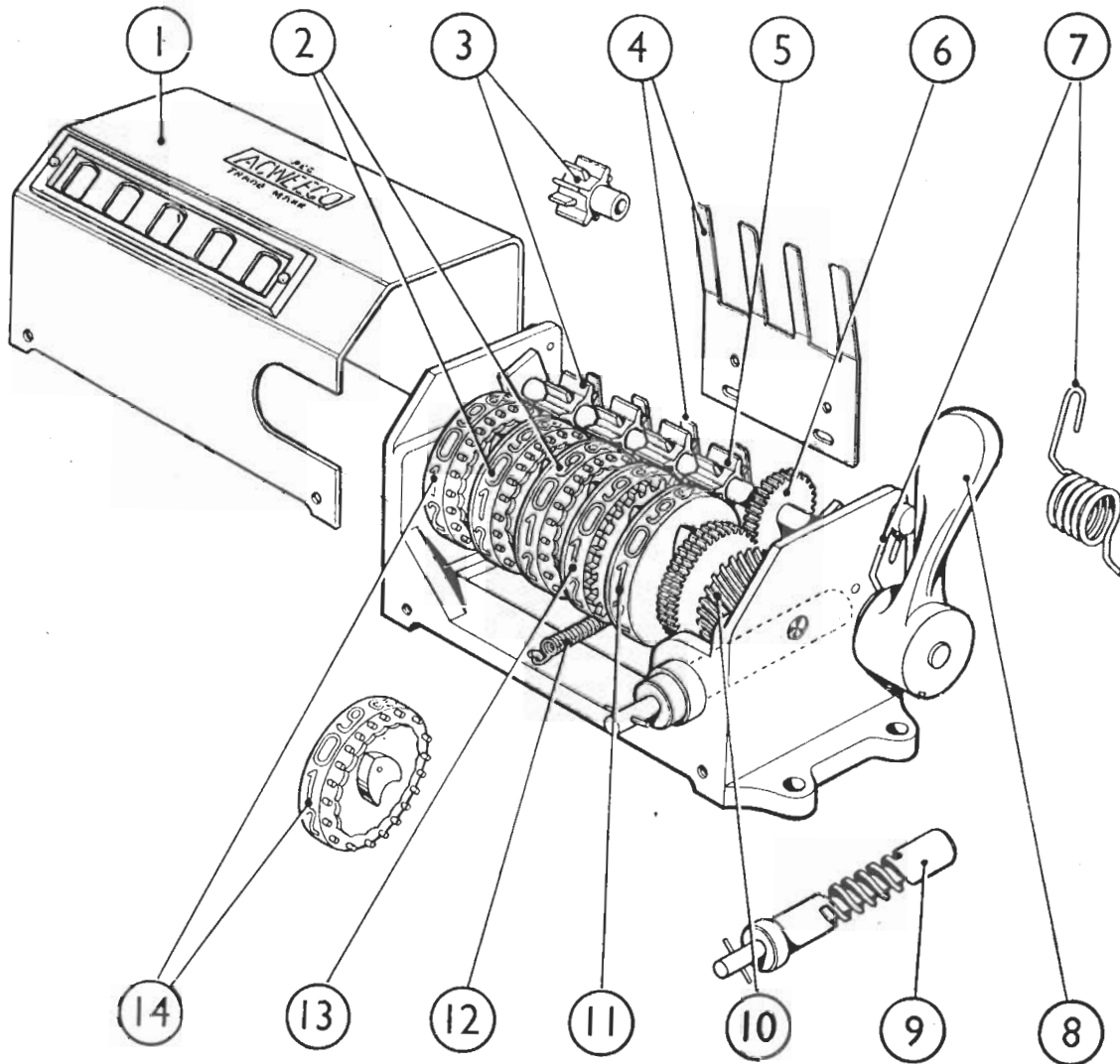

## Plate 5—Parts List

ITEM NO.	DESCRIPTION	PART NO.	NO. OFF	ITEM NO.	DESCRIPTION	PART NO.	NO. OFF
1	Cover . . . . .	11352/1	1	9	R.H. Worm Shaft . . . . .	11368/1	1
2	Indicator Drum, Hundreds and Thousands . . . . .	11355/1	2	10	R.H. Worm Wheel and Pinion . . . . .	11364/1	1
3	Brass Pinion . . . . .	11363/1	3	11	Indicator Drum, Units . . . . .	11353/1	1
4	Reset Locating Spring . . . . .	11357/1	1	12	Return Spring . . . . .	11358/1	1
5	Steel Pinion . . . . .	11362/1	1	13	Indicator Drum, Tens . . . . .	11354/1	1
6	Back Gear Main Pinion and Bush . . . . .	11361/1	1	14	Indicator Drum, Tens of Thousands . . . . .	11356/1	1
7	Reset Spring . . . . .	11359/1	1		Counter Complete R.H. (Clockwise) . . . . .	10217/4	1
8	Reset Lever and Shaft . . . . .	11360/1	1				

**IMPORTANT.** Should the Revolution Counter be constructed with nylon parts, Items 2, 3, 5, 11, 13 and 14 will have part numbers with the suffix /2 instead of /1.

# PLATE 6 BENCH LAY-OUT

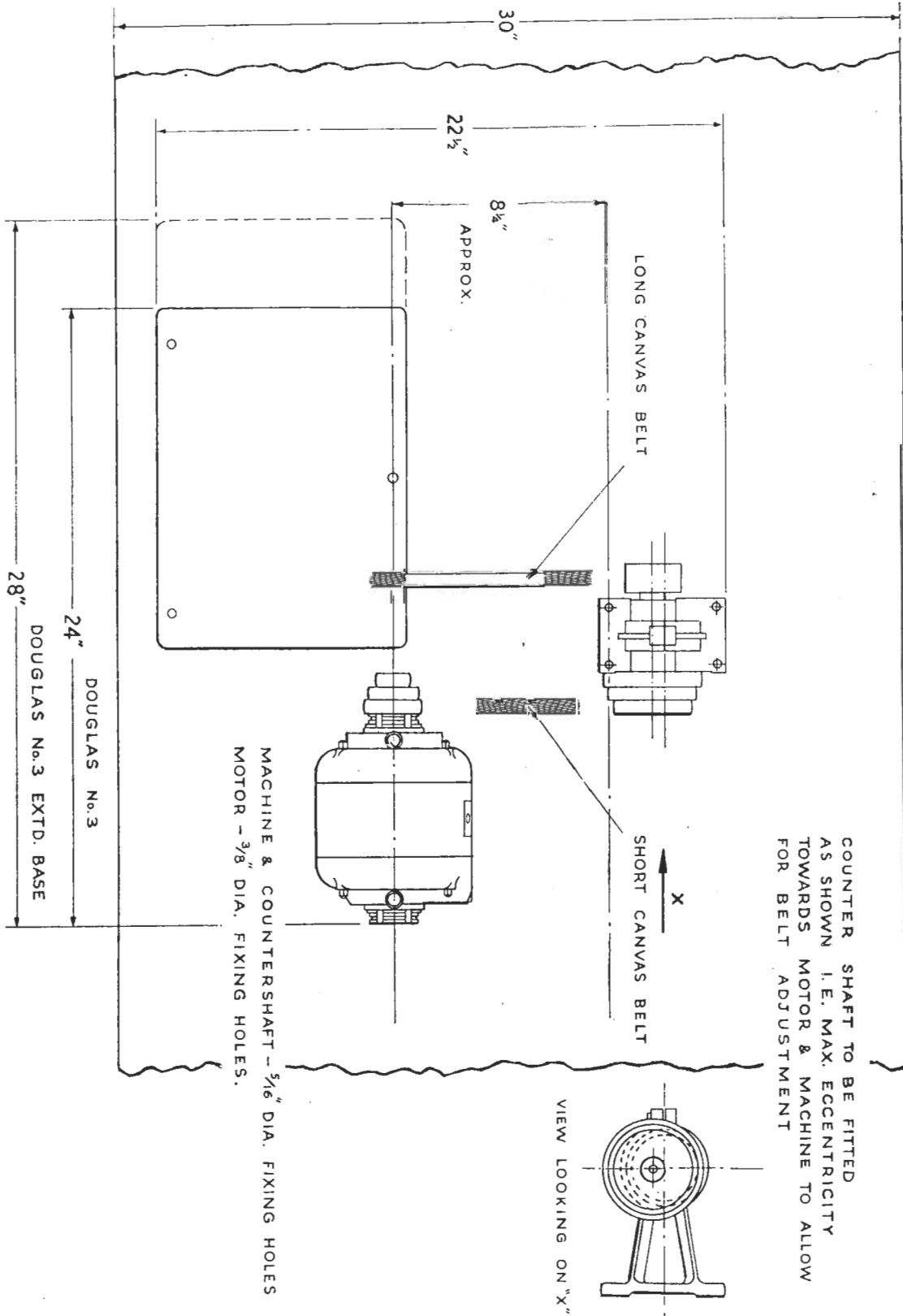

## "DOUGLAS" COIL WINDING MACHINES

OTHER MACHINES IN  
THE "AVO" RANGE

- "DOUGLAS" NO. 6
- "DOUGLAS" NO. 1
- "DOUGLAS" NO. 3
- "MACADIE" S.C.
- "MACADIE" T.D.S.M.
- "DOUGLAS" NO. 15
- "MACADIE" FULLY AUTOMATIC P.I
- "DOUGLAS" H.F.
- "DOUGLAS" NO. 3 EXTENDED BASE
- "DOUGLAS" LARGE MULTI WINDER
- "DOUGLAS" SMALL MULTI WINDER
- "DOUGLAS" DUAL HEAD
- "DOUGLAS" MAGNETO
- "DOUGLAS" SPECIAL EXTENDED BASE NO. 6
- "DOUGLAS" UNIVERSAL REEL CARRIER
- "DOUGLAS" WAVE WINDER
- "DOUGLAS" FLYER DRUM CARRIER
- "DOUGLAS" HEAVY DUTY POWER DRIVEN
- "DOUGLAS" HEAVY DUTY H.F.
- "DOUGLAS" PROGRESSIVE WAVE WINDER
- "DOUGLAS" ELECTROMAGNETIC COUNTERSHAFT
- "DOUGLAS" GENERAL PURPOSE REEL CARRIER



**AVO LIMITED**

AVOCET HOUSE, 92-96, VAUXHALL BRIDGE ROAD, LONDON, S.W.1

*Telephone : Victoria 3404 (9 lines)*