

**INSTRUCTION MANUAL  
MODEL 92E  
R.F. MILLIVOLTMETER**

**BOONTON**  
ELECTRONICS CORPORATION

791 ROUTE 10, RANDOLPH, NJ 07869  
TELEPHONE: 201 — 584-1077 TWX: 710-986-8215

## SAFETY SUMMARY

The following general safety precautions must be observed during all phases of operation and maintenance of this instrument. Failure to comply with these precautions or with specific warnings elsewhere in this manual violates safety standards of design, manufacture, and intended use of the instrument. Boonton Electronics assumes no liability for the customer's failure to comply with these requirements.

### THE INSTRUMENT MUST BE GROUNDED

To minimize shock hazard the instrument chassis and cabinet must be connected to an electrical ground. The instrument is equipped with a three conductor, three prong a.c. power cable. The power cable must either be plugged into an approved three-contact electrical outlet or used with a three-contact to a two-contact adapter with the (green) grounding wire firmly connected to an electrical ground at the power outlet.

### DO NOT OPERATE THE INSTRUMENT IN AN EXPLOSIVE ATMOSPHERE.

Do not operate the instrument in the presence of flammable gases or fumes.

### KEEP AWAY FROM LIVE CIRCUITS.

Operating personnel must not remove instrument covers. Component replacement and internal adjustments must be made by qualified maintenance personnel. Do not replace components with the power cable connected. Under certain conditions dangerous voltages may exist even though the power cable was removed, therefore; always disconnect power and discharge circuits before touching them.

### DO NOT SERVICE OR ADJUST ALONE.

Do not attempt internal service or adjustment unless another person, capable of rendering first aid and resuscitation, is present.

### DO NOT SUBSTITUTE PARTS OR MODIFY INSTRUMENT.

Do not install substitute parts or perform any unauthorized modification of the instrument. Return the instrument to Boonton Electronics for repair to ensure that the safety features are maintained.

### SAFETY SYMBOLS.



This safety requirement symbol (located on the rear panel) has been adopted by the International Electrotechnical Commission, Document 66 (Central Office) 3, Paragraph 5.3, which directs that an instrument be so labeled if, for the correct use of the instrument, it is necessary to refer to the instruction manual. In this case it is recommended that reference be made to the instruction manual when connecting the instrument to the proper power source. Verify that the correct fuse is installed for the power available, and that the switch on the rear panel is set to the applicable operating voltage.



The CAUTION sign denotes a hazard. It calls attention to an operation procedure, practice, or the like, which, if not correctly performed or adhered to, could result in damage to or destruction of part or all of the equipment. Do not proceed beyond a CAUTION sign until the indicated conditions are fully understood and met.



The WARNING sign denotes a hazard. It calls attention to an operation procedure, practice, or the like, which, if not correctly performed or adhered to, could result in injury or loss of life. Do not proceed beyond a WARNING sign until the indicated conditions are fully understood and met.



Indicates dangerous voltages.

# TABLE OF CONTENTS

## SECTION I - GENERAL INFORMATION

Paragraph	Page
1-1 Introduction .....	1-1
Safety Notice .....	1-1
1-2 Description .....	1-1
1-3 Accessories Furnished .....	1-3
1-4 Options and Accessories Available .....	1-3
1-5 Compatibility of Accessories .....	1-4
1-6 Specifications .....	1-4

## SECTION II - INSTALLATION AND OPERATION

2-1 Installation .....	2-1
2-2 Operating Controls and Indicators .....	2-1
2-3 Safety Requirement Symbol .....	2-2
2-4 Initial Operating Procedures .....	2-2
2-5 Operating Notes .....	2-2
2-6 D.C. Output .....	2-4
2-7 Low Frequency Measurements .....	2-5
2-8 Correction Curves for Models 952003-01A and 952007-01A .....	2-5
2-9 Interface Operation .....	2-6

## SECTION III - THEORY OF OPERATION

3-1 Introduction .....	3-1
3-2 Circuits: Detailed Discussion .....	3-2
A. Sensor .....	3-2
B. Chopper .....	3-2
C. Amplifier .....	3-2
D. Demodulator .....	3-3
E. Driver .....	3-3
F. Clock .....	3-3
G. Ranging and Programming .....	3-4
H. Shaping .....	3-4
I. Power Supply .....	3-7

## SECTION IV - MAINTENANCE

4-1 Introduction .....	4-1
4-2 Periodic Calibration .....	4-1
4-3 Power Supply Checks .....	4-1
4-4 Calibration Check .....	4-1
4-5 Calibration Procedure .....	4-2
4-6 Troubleshooting .....	4-5
A. Cover Removal .....	4-5
B. Replacement of R.F. Probes .....	4-5
C. Probe Tests .....	4-5
1. S.W.R. Measurement .....	4-5
2. Frequency Response .....	4-6
3. Swept Frequency Response and S.W.R. ....	4-7

## SECTION V - PARTS LIST

Paragraph	Page
5-1 Introduction .....	5-1

## SECTION VI - SCHEMATIC DIAGRAMS

6-1 Schematic Diagrams, Table of Contents .....	6-1
---	-----

## LIST OF ILLUSTRATIONS

Figure	Page
1-1 Input Resistance of Model 92001-02A R.F. Probe .....	1-6
1-2 Input Capacitance of Model 92001-02A R.F. Probe .....	1-7
2-1 Assembly of Type N Tee Adapter .....	2-3
2-2 Correction Curves for Type N Tee Adapters .....	2-5
2-3 Rear Panel Pin Assignments .....	2-6
3-1 Simplified Block Diagram .....	3-1
3-2 Block Diagram: Amplifier Section .....	3-3
3-3 Block Diagram: Demodulator and Driver .....	3-4
3-4 Block Diagram: Ranging Circuitry .....	3-5
3-5 Block Diagram: Shaping Section .....	3-6
3-6 Block Diagram: Power Supply .....	3-8
4-1 Adjustment Locations and Descriptions .....	4-3
4-2 Frequency Response Test Setup .....	4-6
4-3 Swept Frequency Response Test Setup .....	4-8

## LIST OF TABLES

Table	Page
1-1 Crest Factors .....	1-7
2-1 Operating Controls, Indicators and Connectors .....	2-1
2-2 Connection Recommendations .....	2-3
2-3 Rear Panel Pins: Unit Loadings and Comments .....	2-6
2-4 Interface Input Characteristics .....	2-7
5-1 Applicable Federal Supply Code Numbers for Manufacturers .....	5-1
5-2 Replaceable Parts .....	5-2

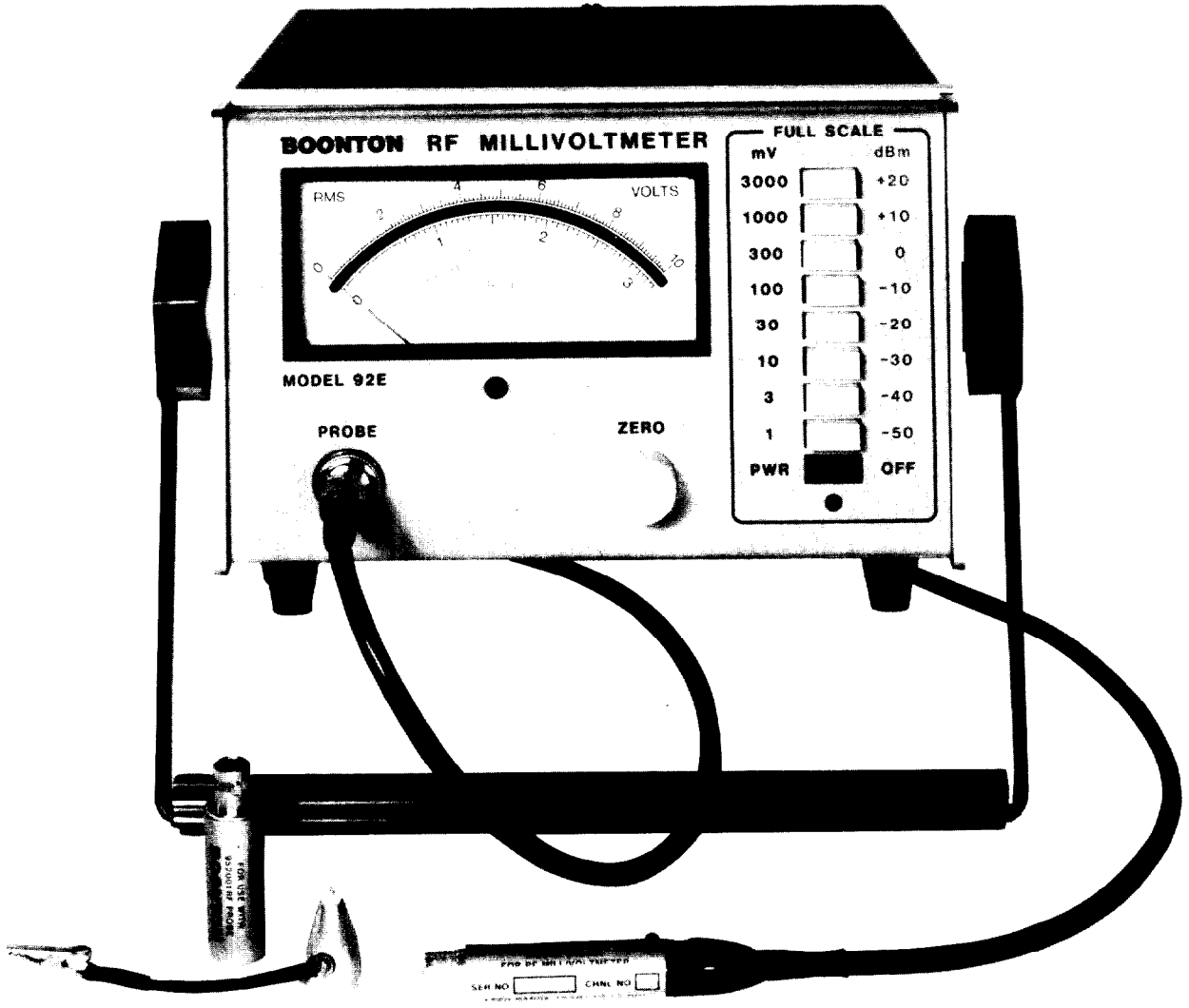

92E RF Millivoltmeter

SECTION I  
GENERAL INFORMATION

1-1. INTRODUCTION.

This instruction manual provides general information, installation and operating instructions, theory of operations, maintenance instructions, a parts lists, and schematics for the Model 92E.

SAFETY NOTICE

Although this instrument has been designed in accordance with international safety standards, general safety precautions must be observed during all phases of operation and maintenance of the instrument. Failure to comply with the precautions listed in the Safety Summary located in the front of this manual could result in serious injury or death. Service and adjustment should be performed only by qualified service personnel.

1-2. DESCRIPTION

A. General. The 92E R.F. Millivoltmeter provides an accurate readout of measurements from the low radio frequencies to the gigahertz region, over a voltage range of 200  $\mu$ V to 3 volts.\* It is a programmable, solid state instrument of high sensitivity and accuracy, characterized by high input impedance (see Figures 1-1 and 1-2), excellent stability, and low noise.

The 92E exhibits true r.m.s. response for input signals up to 30 millivolts gradually approaching peak-to-peak above this level.† The meter, however, is calibrated to indicate r.m.s. of a sine wave above 30 mV.

Input and output connections for external control and readout are provided by a 22 pin card edge connector at the rear of the instrument.

A linear d.c. output, the level of which is proportional to the r.f. input voltage, is also provided at a rear connector. This d.c. output may be used to drive a recorder, a remote indicator, or other analog devices.

The instrument is sensitive, accurate, sturdily constructed, and protected against overloads. It will perform over extended periods of time without failure or need for recalibration. It is packaged as a compact bench instrument that can be mounted easily in a standard 19 inch rack, using an optional rack mounting kit.

B. Accessories Supplied. Standard accessories supplied with the Model 92E include one each of the following:

Model 952001-02A R.F. Probe with low noise cable and connector.

Model 952002-01A 50 Ohm BNC Adapter.

Model 952004-01A Probe Tip (removable), with grounding clip lead.

C. Frequency Capability. The calibrated frequency range of the Model 92E extends from 10 kHz to 1.2 GHz, with uncalibrated response to beyond 8 GHz. Relative accuracy\* above 1.2 GHz is typically  $\pm 0.5$  dB.

A 952002-01A, 50 Ohm BNC Adapter, is supplied as a standard accessory with the instrument for 50 ohm voltage measurements up to 1.2 GHz.

For through line voltage measurements the optional accessory 952003-01A Tee Adapter is recommended. It is designed to compensate for the r.f. probe

---

\*To 300 V, up to 700 MHz, with accessory 100:1 divider.

†To 3 V, up to 700 MHz, with accessory 100:1 divider.

## §1.2, Continued.

capacitance and to present a good s.w.r. (better than 1.15) up to 1.2 GHz. It may be used in conjunction with the Model 952028-01A 50 Ohm Load for terminated voltage measurements. In a coaxial line its insertion loss is low; however, a graph (Figure 2-2) is supplied, showing loss vs. frequency.

For lower frequency measurements, the Model 91-4C R.F. Probe is available as an optional accessory. Its frequency range is 1 kHz to 250 MHz.

D. Voltage Capability. The voltmeter has eight ranges, from 1 mV, f.s., to 3 V, f.s., arranged in a 1-3-10 sequence. No attenuator attachments are required for measurements up to 3 V. While this range is ample for most radio frequency voltage measurements, the capability of the instrument can be increased to 300 V (up to 700 MHz), by using an optional accessory, the high impedance 100:1 Voltage Divider. Use of this 100:1 Voltage Divider also increases the input resistance by a factor of 1000 to 3000, depending upon the input level.

E. True R.M.S. Response. The Model 92E provides true r.m.s. response for signal inputs below approximately 30 mV (below 3 V, up to 700 MHz, with the 100:1 Voltage Divider). As the input level increases, the waveform response gradually approaches peak-to-peak, calibrated on the indicator in r.m.s.

F. Low Noise. The Model 92E has been designed and constructed to hold noise from all sources to a minimum. The probe cable is of special low noise design; a vigorous flexing causes only momentary, minor deflections of the meter on the most sensitive range. The probe itself is insensitive to shock or to vibration.

Amplification takes place at 94 Hz, reducing susceptibility to any 50 or 60 Hz line frequency related fields. The input signals from the probe are converted into 94 Hz signals by a solid state chopper.

G. Minimal Zero Adjustment. Zero adjustment is not required on the upper five sensitivity ranges of the voltmeter. For measurements on the lower three ranges, the ZERO control is adjusted on the most sensitive range before operation. Only infrequent checking will be required during the course of subsequent measurements.

H. D.C. Output. The Model 92E provides a linear d.c. output whose current capability of 1 mA into 1000 ohms is extremely stable. When used as part of an automatic test system, the fast response of the instrument's d.c. output to an input step function allows many tests per unit time.

For system or external requirements, all input and output connections for the 92E are made at the card edge connector at the rear of the instrument. (See §2-9 for receptacle connections.)

## 1-3. ACCESSORIES FURNISHED

A. Model 952001-02A, R.F. Probe. Probe with low noise cable and connector assembly for measurements from 10 kHz to 1.2 GHz; see Figures 1-1 and 1-2 for input resistance and capacitance.

B. Model 952004-01A, Probe Tip. Removable probe tip with grounding clip lead; for use up to approximately 100 MHz.

C. Model 952002-01A, 50  $\Omega$  BNC Adapter. Used for measurements up to 1.2 GHz in a 50 ohm system.

---

\*Relative accuracy refers to the differential between two measured levels without regard to the absolute accuracy of either measurement. A measurement of a 100 mV signal at 8 GHz may indicate 20 mV on the meter; then a 50 mV signal, at that same frequency, will be indicated as 10 mV, within about 0.5 dB (5.9%).

#### 1-4. OPTIONS AND ACCESSORIES AVAILABLE

Option -04: dBV scale uppermost.  
Option -06: 75  $\Omega$  dBm scale uppermost.  
Option -08: Rear signal input.  
Option -12: dBmV scale uppermost.

Accessory 91-4C: Special 1 kHz to 250 MHz R.F. Probe. Low-frequency probe for measurements ranging from 1 kHz to 250 MHz; input resistance is essentially the same as that of the Model 952001-02A Probe (see §1-3A).

Accessory 91-16A: Unterminated N Adapter. May be used with all probes. Used for coaxial connection up to approximately 100 MHz, or to 400 MHz when fed from a 50 ohm source in an electrically short system.

Accessory 950002-01B: Single Rack-Mounting Kit. Kit for mounting one 92E as one half of a module in a standard 19 inch rack.

Accessory 950030-01A: Double Rack-Mounting Kit. Kit for mounting two 92E's side by side in a standard 19 inch rack.

Accessory 952003-01A: 50  $\Omega$  Tee Adapter. Type N Tee connector; used with Model 952028-01A termination, it permits connection into a 50 ohm line. See Figure 2-2 for insertion loss vs. frequency.

Accessory 952005-01A: 100:1 Voltage Divider. Attenuates input signal by a factor of  $100 \pm (1 + f_{\text{MHz}}/200)\%$ , permitting measurements up to 300 V, and extending the r.m.s. measuring range to 3 V; also increases input resistance by a factor of 1000 to 3000, depending upon input level. Operates from 50 kHz to 700 MHz. Maximum input potential, 1000 V, d.c. plus peak a.c.

Accessory 952006-01A: 75  $\Omega$  BNC Adapter. Used for measurements up to 500 MHz in a 75 ohm system.

Accessory 952007-01A: 75  $\Omega$  Tee Adapter. Type N Tee connector; used with Model 952029-01A termination, it permits connection into a 75 ohm line. See Figure 2-2 for insertion loss vs. frequency.

Accessory 952008-01A: Unterminated BNC Adapter (Female). Used for coaxial connection up to approximately 100 MHz, or to 400 MHz when fed from a 50 ohm source in an electrically short system.

Accessory 952028-01A: 50  $\Omega$  Termination. Type N 50 ohm termination for use with Tee connector.

Accessory 952029-01A: 75  $\Omega$  Termination. Type N 75 ohm termination for use with Tee connector.

Accessory 952011-01A: Accessory Kit, 50  $\Omega$ . Kit contains the following above mentioned items: 952008-01A, unterminated BNC adapter (F); 952005-01A, 100:1 voltage divider; 952003-01A, 50  $\Omega$  Tee adapter; 952028-01A, 50  $\Omega$  termination; Model 952013-01A, Storage Case (case for protecting and storing kit accessories).

Accessory 952012-01A: Accessory Kit, 75  $\Omega$ . Contains the following above-mentioned items; 952008, unterminated BNC adapter; 952005, 100:1 divider; 952007, 75 ohm Tee adapter; 952015, type N 75 ohm termination; and 952013 storage case.

#### 1-5. COMPATIBILITY OF ACCESSORIES

Accessory models 952002-01B - 952029-01A, described above, appear similar to some older accessories with model numbers type 91-xx. (The newer accessories have black printing on a silver colored background; the older accessories have silver colored printing on a black background.)



The 952001-02A R.F. Probe can be used with these older accessories. However, the frequency dependent specifications given in this manual for the use of the 952001-02A R.F. Probe in combination with an accessory apply ONLY to its use with the newer accessories.

### 1-6. SPECIFICATIONS

VOLTAGE RANGE: 200  $\mu$ V to 3 V (300 V up to 700 MHz with accessory 100:1 voltage divider). Lowest detectable voltage is approximately 100  $\mu$ V.

FULL-SCALE VOLTAGE RANGE: 1, 3, 10, 30, 100, 300, 1000, and 3000 mV.

dBm RANGE: -61 to +23 dBm (+63 dBm up to 700 MHz with optional accessory, 100:1 Voltage Divider).

FREQUENCY RANGE: 10 kHz to 1.2 GHz (uncalibrated response to approximately 8 GHz).

ACCURACY: The maximum uncertainty is the sum of the uncertainties given in sections A, B, and C.

#### A1. Basic Uncertainty, Voltage

<u>Voltage Level</u>	<u>mV</u>
200 $\mu$ V - 3000 mV	1% f.s.

#### A2. Basic Uncertainty, dBm

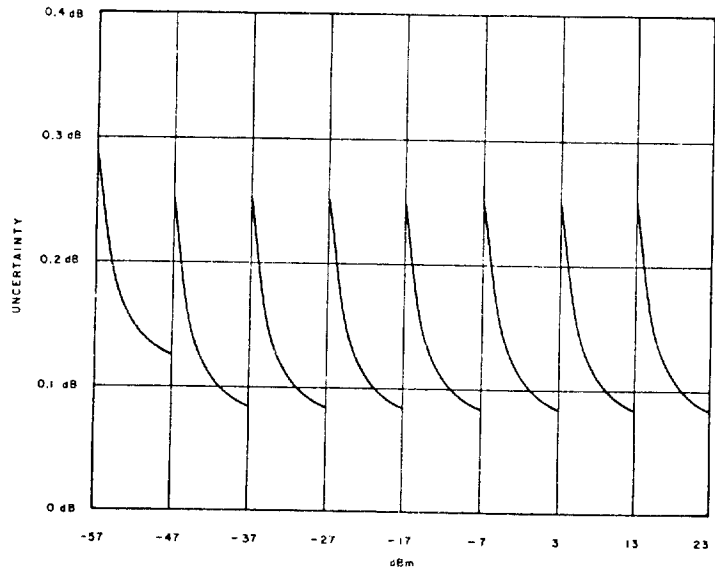

§1-6, Continued.

B. Frequency Effect

(50 ohm measurements, using Model 952001-02A Probe with Model 952002-01B BNC Adapter or terminated Model 952003 Type N Tee Adapter.)

Frequency	mV	dBm
1 MHz (Cal. frequency)	0	0
10 kHz - 100 MHz	1% rdg.	0.09 dB
100 MHz - 1 GHz	3% rdg.	0.27 dB
1 GHz - 1.2 GHz	10% rdg.	0.92 dB

S.W.R.: 1.05 to 300 MHz; 1.10 to 1 GHz;  
1.15 to 1.2 GHz.

C. Temperature Effect, at 1 MHz.

Temperature Range	mV Ranges		dBm Ranges	
	Instrument	R.F. Probe	Instrument	R.F. Probe
21°C to 25°C	0	0	0	0
18°C to 30°C	0.2% rdg.	1% rdg.	0.02 dB	0.09 dB
10°C to 40°C	0.5% rdg.	5% rdg.	0.04 dB	0.45 dB
0°C to 55°C	1% rdg.	12.5% rdg.	0.09 dB	1.16 dB

METER:

4 1/2-inch taut-band  
Two linear voltage scales:  
0 to 3; 0.05 per division  
0 to 10; 0.1 per division  
One logarithmic dBm scale:  
-10 to +3; 0.2 per division, max.

METER UNREST:  
(1 mV f.s. range, only)

Indicated Voltage	Unrest
Above 600 $\mu$ V	< 1% f.s.
300 $\mu$ V to 600 $\mu$ V	< 2% f.s.
200 $\mu$ V to 300 $\mu$ V	< 5% f.s.

R.F.I.:

There is no detectable radiated or conducted leakage from the instrument or the probe.

POWER SENSITIVITY:

800 pW, minimum measurable power in 50 ohms.  
Minimum detectable power in 50 ohms is 200 pW.

WAVEFORM RESPONSE:

True r.m.s. response for input levels up to 30 mV (3 volts to 700 MHz using the 100:1 Voltage Divider), with transition to peak-to-peak (calibrated in r.m.s.) at higher levels.

CREST FACTOR:

420 to 1.4, depending upon input level (see Table 1-1).

INPUT IMPEDANCE:

See Figures 1-1 and 1-2.

§1-6, Continued.

S.W.R.: Less than 1.15 to 1.2 GHz (return Loss greater than 23 dB).

D.C. OUTPUT: 0 to 10 V, d.c., proportional to r.f. input voltage. Source resistance of 9 k $\Omega$ ; will deliver 1 mA into 1 k $\Omega$  load. Full-scale input step function response time less than 100 ms on 30 mV, f.s., to 3 V, f.s., ranges, increasing to 1 s on the 1 mV, f.s., range.

WARM UP: Warm up period typically 1 min. Adjust ZERO on 1 mV range when measuring below 30 mV.

POWER: 100, 120, 220, 240 V  $\pm$ 10%, 50 to 400 Hz.

OPERATING AND STORAGE TEMPERATURES:

- A. Operating: 0°C to +55°C
- B. Storage: -55°C to +75°C

DIMENSIONS: 132 mm high (without rubber feet)  $\times$  211 wide  $\times$  292 deep (5.2 in.  $\times$  8.3  $\times$  11.5).

WEIGHT: Net 3.2 kg (7 lbs).

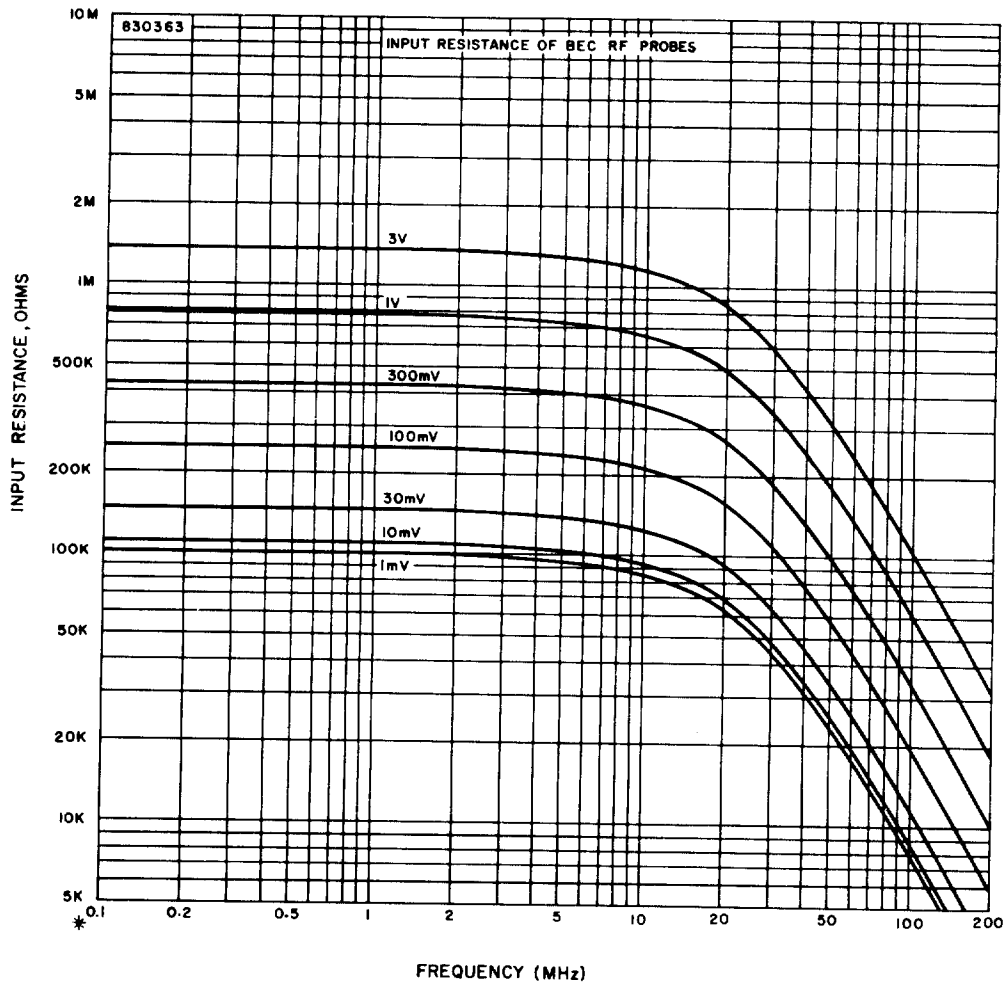

\*Curves extend down to 10 kHz without change.

Figure 1-1. Input Resistance of Model 952001-02A R.F. Probe as a Function of Input Level and Frequency

Table 1-1. Crest Factors

VOLTAGE RANGES (mV)	1	3	10	30	100*	300*	1000*	3000*
CREST FACTOR†	420 to 42	70 to 14	21 to 4.2	7 to 1.4	420 to 42	70 to 14	21 to 4.2	7 to 1.4

\*With accessory 100:1 Voltage Divider, Model 952005-01A.

†Maximum permissible ratio of peak-to-r.m.s value of voltage.

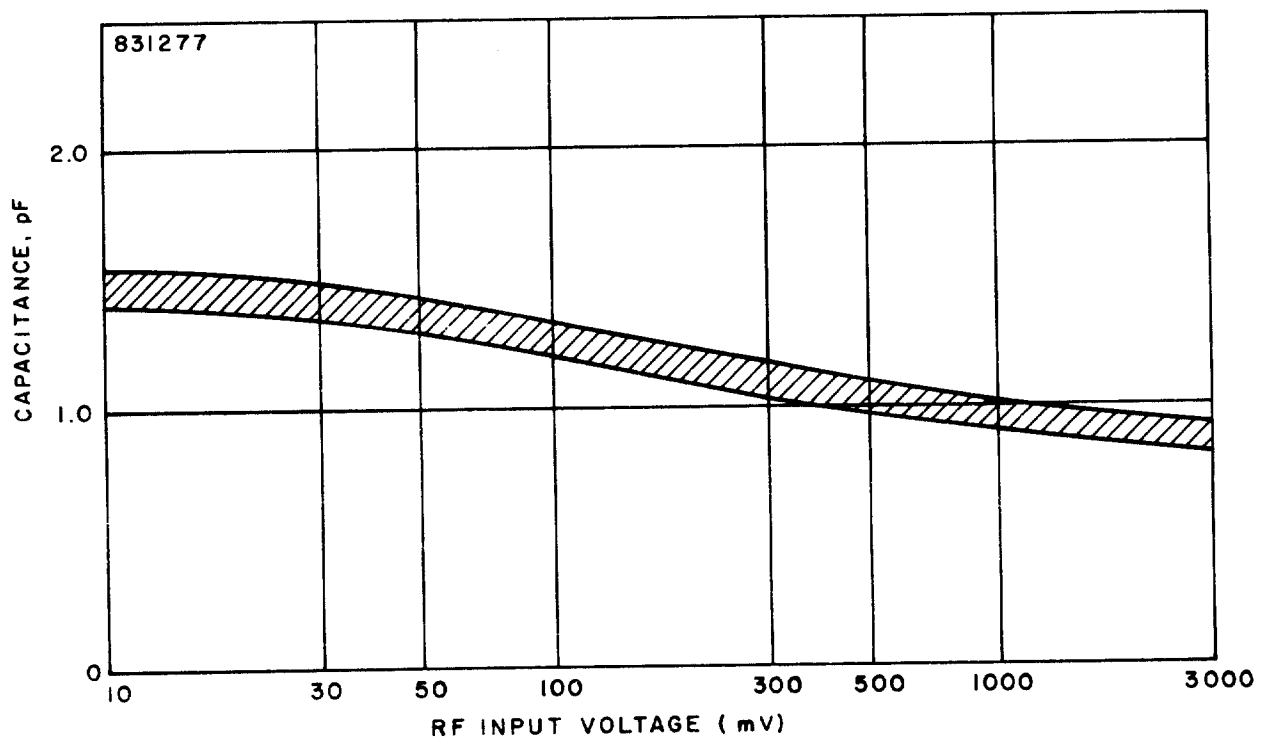

Figure 1-2. Input Capacitance vs. Input Level, Model 952001-02A R.F. Probe

## SECTION II

### INSTALLATION & OPERATION

#### 2-1. INSTALLATION

The Model 92E has been inspected and tested at the Factory before packing, and it is shipped ready for operation. If there is any indication of shipping damage, immediately notify the carrier before attempting to put the instrument into operation.

#### 2-2. OPERATING CONTROLS AND INDICATORS

All controls, indicators and connectors used during operation of the 92E are described in Table 2-1, below.

Table 2-1. Operating Controls, Indicators, and Connectors

ITEM	FUNCTION
PWR OFF Switch	Depressing this switch turns the 92E "off".
FULL SCALE Pushbuttons	Depressing any full scale range pushbutton will turn "on" the 92E and select the operating range.
LED Indicator	This red light emitting diode is lit when the 92E is turned "on".
Meter	Taut-band meter with two linear voltage scales and one logarithmic dBm scale.
PROBE Jack	The probe cable connects to the 92E through this jack. Always check that the knurled ferrule nut of the probe-cable connection is tightened.
ZERO Control	This control is used to "zero" the 92E on its three most sensitive ranges.
Fuse Holder (Rear Panel)	The fuse holder should have installed in it one of the following fuses: 0.2A, for 100, 120 V; 0.1 A, for 220, 240 V.
Slide Switches (Rear Panel)	Switches are to be set to 100, 120, 220, or 240 V, according to the available line voltage. (Be sure that the proper fuse is installed.)
Analog Output (Rear Panel)	A d.c. voltage proportional to the meter reading is available at these terminals.
REMOTE CONNECTIONS (Rear Panel)	The card edge plug is intended for use with an Amphenol 225-22221-101 connector, or equivalent. See Table 2-3 for pin designations.

### 2-3. SAFETY REQUIREMENT SYMBOL



This safety requirement symbol (on the rear panel) has been adopted by the International Electrotechnical Commission, Document 66 (Central Office) 3, Paragraph 5.3, which directs that an instrument be so labeled if, for the correct use of the instrument, it is necessary to refer to the instruction manual. In this case it is recommended that reference be made to the instruction manual when connecting the instrument to the proper power source. Verify that the correct fuse is installed for the power available, and that the switch on the rear panel is set to the applicable operating voltage.

### 2-4. INITIAL OPERATING PROCEDURES

- A. Be sure that the serial number of the probe to be used is the same as that of the voltmeter. (Each instrument is calibrated for its particular r.f. probe.) Use of a probe other than that for which the instrument was calibrated may result in measurement errors.
- B. Connect the probe cable to the PROBE jack on the front panel.
- C. Check the setting of the power switch on the rear panel to be sure that it is set to the proper position for the line voltage in use.
- D. Plug the instrument's power cable into a power receptacle. Press any Full Scale Range pushbutton to turn the instrument on.
- E. Press the 1 mV range pushbutton; the panel meter pointer should rest on zero. If it does not, use the ZERO control to set the meter to zero. (This adjustment will hold for the other ranges.) The instrument is now ready for use. (See §2-5E.)

### 2-5. OPERATING NOTES

While using the Model 92E is a direct and straight forward process, there are certain precautions and procedures which MUST be observed to obtain satisfactory results.

- A. Overload Limits. The 952001-02A R.F. Probe supplied with the instrument is overload protected to 10 V, a.c., and to 400 volts, d.c. EXCEEDING THESE LIMITS MAY RESULT IN PERMANENT DAMAGE TO THE PROBE.

The 952002-01A 50 ohm adapter should not be subjected to continuous overload of more than 3 volts [d.c. + (a.c., r.m.s.)], to avoid excessive heating of the terminating resistor.

Where voltages above these limits are likely to be encountered, the 952005-01A 100:1 Voltage Divider is required. Maximum rating of the Voltage Divider is 1000 volts, d.c. + peak a.c.

- B. Connection for Measurements below 100 MHz. The R.F. Probe supplied with the 92E is equipped with a detachable tip and ground lead. For signal measurements below approximately 100 MHz, this tip provides a convenient means for both signal and ground connection.
- C. Connection for Measurements above 100 MHz. For frequencies above 100 MHz, the probe tip should NOT be used with the Model 92E. Connection should be made directly to the probe's center contact, with the ground connection kept as short as possible.

The connection recommendations outlined in Table 2-2 should be followed in order to maintain the specified accuracy.

Table 2-2. Connection Recommendations

FREQUENCY	SIGNAL CONNECTION
Up to 100 MHz	Probe with tip and ground lead, or with Model 952002-01A (supplied) Probe with Model 952003-01A/952028-01A (optional)
100 to 250 MHz	Probe without tip, or probe with Model 952002-01A (supplied) Probe with Model 952003-01A/952028-01A (optional)
250 MHz - 1.2 GHz	Probe with Model 952002-01A (supplied) Probe with Model 952003-01A/952028-01A (optional)

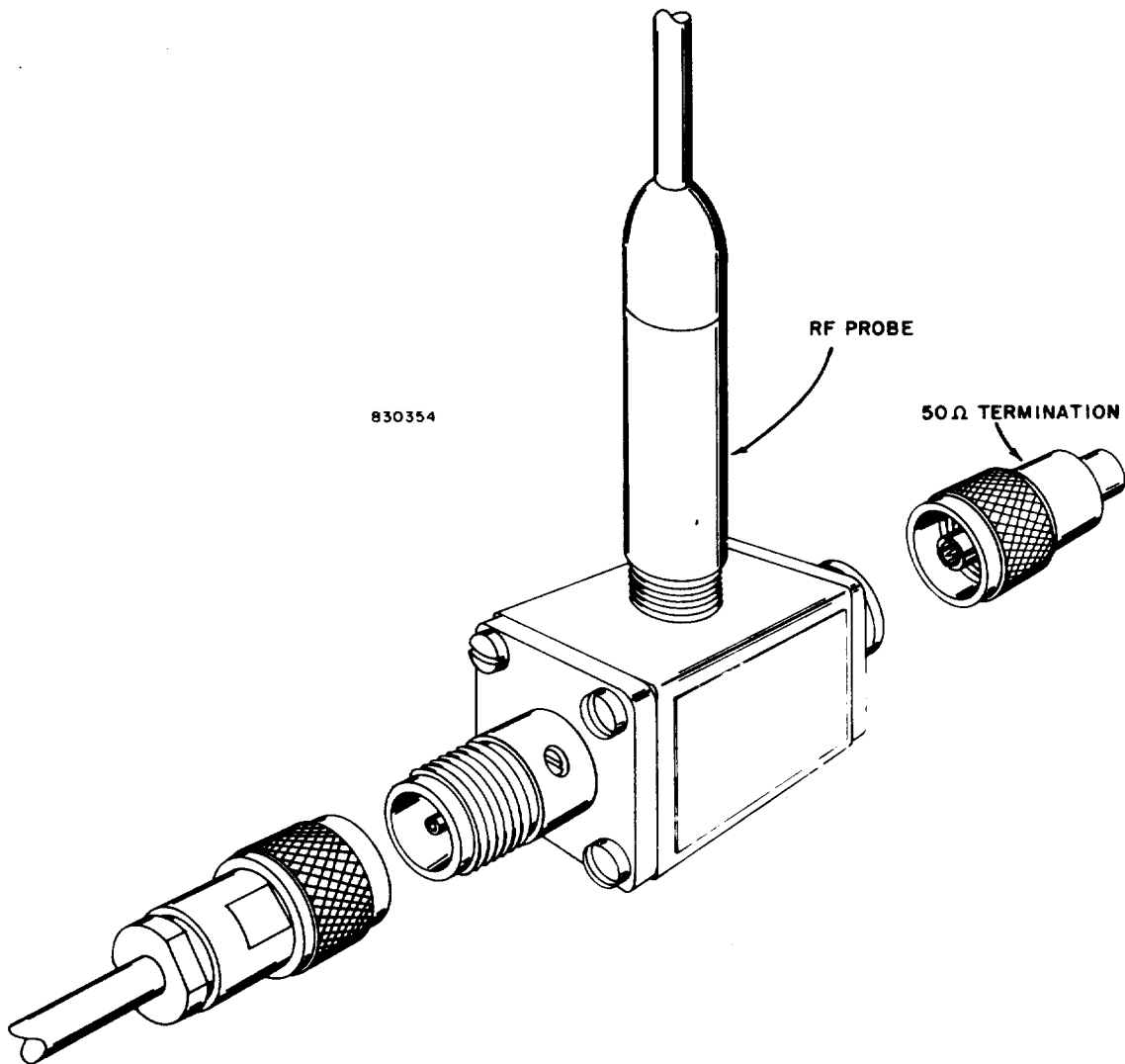

Figure 2-1. Assembly of Type N Tee Adapter

§2-5, Continued.

D. Low Level Measurement. The voltmeter will provide reliable, reproducible measurements of signal levels as low as 200 microvolts.

Preliminary zero adjustment is essential when using the lowest range scale to achieve the specified accuracy, and it is strongly recommended for all ranges up to 30 mV.

E. Making the Zero Adjustment. When the instrument is to be used on the 1 mV range, the following zero adjustment procedure should be followed.

1. Set the FULL SCALE range selector to the 1 mV position.
2. Be sure that no voltage is applied to the probe, and that it is adequately shielded from local fields. This can be done by partially unscrewing the probe cap until the tip just breaks contact with the internal connector, leaving the metal shell engaged with the body threads. Alternatively, the probe tip can be removed and the 50 ohm termination (Model 952002-01A) mounted in its place.
3. Adjust the ZERO control to bring the meter reading to zero. Noise may cause the reading to fluctuate. If so, adjust the ZERO control so that the reading averages zero.

F. Signal Overload on 1 mV Range. On the most sensitive (1 mV) range, the application of a large a.c. signal overloads the amplifier and a short time is required for the high impedance input circuit to discharge. This effect is significant for signals above approximately 100 millivolts. Typically, application of a 1 volt signal will require a recovery time of about thirty seconds before subsequent measurements should be made on the 1 mV range. It should be noted, however, that such overloads cause no damage to the equipment as long as they are within the limits outlined in §2-5A.

G. Temperature Effects. Over the range of 21°C to 25°C (70°F to 77°F), temperature effects for the Model 92E and the Model 950001 R.F. Probe are sensibly zero. Outside of these limits, inaccuracies can be expected as described in the Specifications section (see §1-6C). However, no permanent change in probe characteristics will result from exposure to any reasonable high or low temperature.

Inaccuracies of measurement resulting from temperature effects may occur shortly after soldering to the probe tip, or when measuring with the probe close to heat sources such as resistors, heat sinks, vacuum tubes, etc.

When making low level measurements (below approximately 2 millivolts) it is important to make sure that the probe has attained a uniform temperature throughout its body. A temperature gradient between the inside and the outside of the probe can generate a small thermal voltage that may add to the d.c. output of the detector diodes.

H. Hum, Noise and Spurious Pick-up. When measuring low level signals, precautions should always be taken to avoid the possibility of errors of measurement resulting from hum, noise or stray r.f. pick-up. Although all low frequency hum and noise are attenuated at the input, it is still possible for unwanted high level signals to cause errors. In some cases it may be necessary to provide extra shielding around the probe connections to reduce stray pick-up. Typical sources of spurious radiation are: induction or dielectric heating units, diathermy machines, local radio transmitters, and grid dip meters.

## 2-6. D.C. OUTPUT

The d.c. output provided at the rear panel binding posts is a linear function (typically within 1%) of the input level, as long as the input signal is greater than 20% of full scale. The polarity of the d.c. output is positive with respect to the instrument ground, the negative d.c. output terminal being at ground potential. The output resistance is 9 kΩ.



## 2-7. LOW FREQUENCY MEASUREMENTS

The 952001-02A R.F. Probe supplied with the 92E provides measurements within the specified accuracy from 10 kHz to 1.2 GHz. For measurements at lower frequencies the Model 91-4C R.F. Probe is available. It operates over a frequency range from 1 kHz to 250 MHz.

NOTE: After installing the 91-4C R.F. Probe, the Model 92E MUST BE checked for accuracy of calibration. The voltmeter must be recalibrated, if it is required. (See §4-4 and §4-5.)

## 2-8. CORRECTION CURVES FOR MODELS 952003-01A AND 952007-01A

Use the curves of Figure 2-2 to make corrections for transmission loss when using the Type N 50  $\Omega$  or 75  $\Omega$  Tee Adapters.

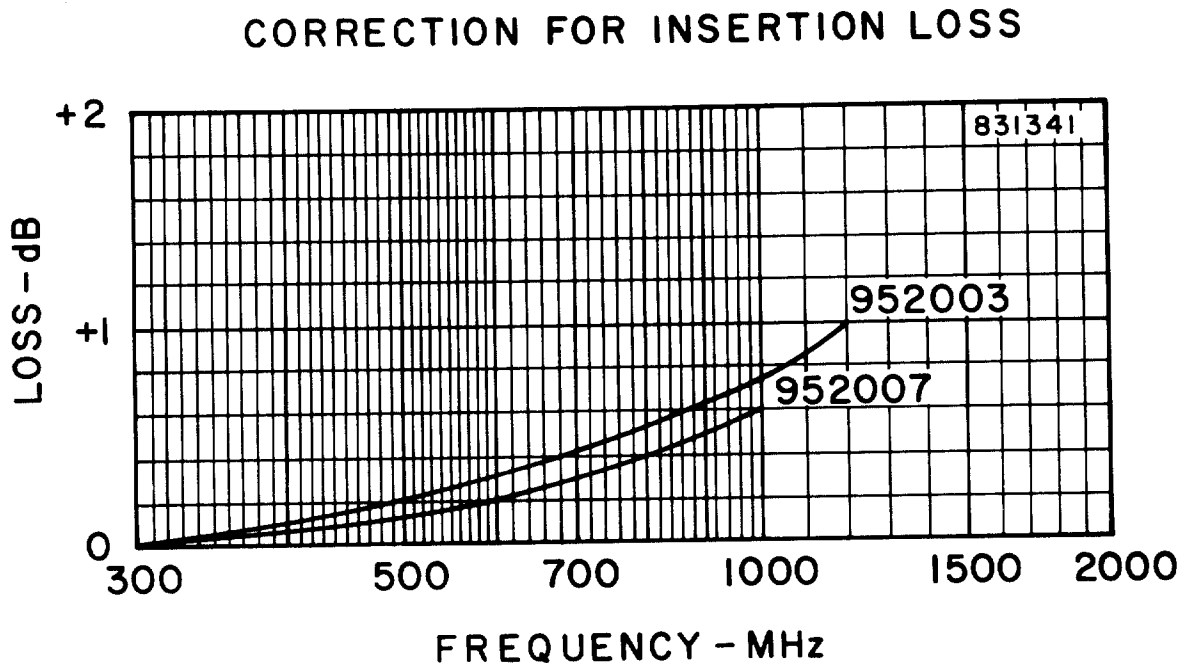

### NOTES:

- 1) The Insertion Loss shown is that which exists between the input and output ports of the Tee.
- 2) The R.F. Millivoltmeter measures the input voltage of the Tee.
- 3) Therefore, if the output voltage of the Tee is to be determined, subtract the Insertion Loss determined from the graph from the value that is indicated on the R.F. Millivoltmeter.
- 4) Do not use the correction if terminated measurements are required (i.e., measurements with Model 952028-01A or Model 952029-01A terminations installed on the output port of the Tee).

Figure 2-2. Correction Curves for Type N Tee Adapters Models 952003-01A (50  $\Omega$ ), and 952007-01A (75  $\Omega$ )

## 2.9 INTERFACE OPERATION

Remote programming is accomplished by simultaneously shorting to common the Manual Disable and the appropriate range lines on the card edge connector located at the rear of the 92E. (In effect, when Manual Disable is brought to common, the front panel switches are disconnected.)

A pictorial presentation of the rear panel programming inputs and data output connections is given in Figure 2-3. Table 2-3 provides additional data on these connections.

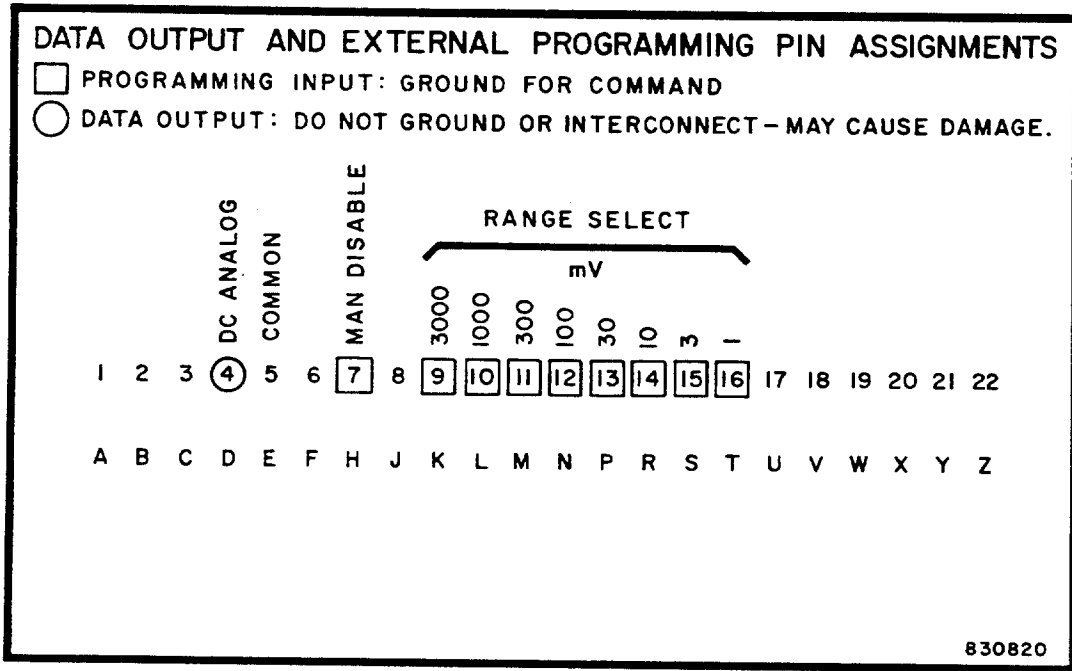

Figure 2-3. Rear Panel Pin Assignments

Table 2-3. Rear Panel Pins: Unit Loadings and Comments

Pin No.	Function	Comment	Command	Unit Loading
7	Man.Disable	Disables front-panel range selection	0	0.1
16	1 mV range	Selects range, provided that Manual Disable has also been selected. Selecting more than one range will result in incorrect indications. Range lines must be de-selected for manual operation.	0	0.1
15	3 mV "		0	0.1
14	10 mV "		0	0.1
13	30 mV "		0	0.1
12	100 mV "		0	0.1
11	300 mV "		0	0.1
10	1 V "		0	0.1
9	3 V "		0	0.1
5 4	Common D.C. Analog	Power line ground at rear panel. +10 V for full scale of "1" ranges; +9.5 V for "3" ranges.	N/A N/A	N/A N/A

§2-9, Continued.

A. Input Characteristics. Interface input characteristics are given in Table 2-4.

Table 2-4. Interface Input Characteristics

TTL Series	Logic Level	Voltage Level	Current per Unit Load
Standard Power 54/74	0	±0.7 V	±1.6 mA*
	1	2.4 to 5.25 V	40 µA

\*The "-" current indicates current out of the input (the external command device must sink this current). A standard power (Series 54/74) TTL output will sink and source 10 unit loads.

B. Input Pull-Up. All input terminals have internal pull-up. The current sourced by this pull-up when the input is brought to a logic level 0 is included in the loading shown in the "Unit Loading" column of Table 2-3.

C. D.C. Analog Output.

1. Polarity: positive with respect to instrument ground. (The negative D.C. Analog Output terminal is at ground potential.)
2. Source Resistance: 9 kΩ.

## SECTION III

### THEORY OF OPERATION

#### 3-1. INTRODUCTION

For this discussion, refer to Figure 3-1, a block diagram of the Model 92E. The r.f. voltage to be measured by the 92E is applied to a sensor, which converts the r.f. voltage to a proportional d.c. voltage. The output voltage from the sensor ranges from a fraction of a millivolt to volts, as a function of the input voltage level to the sensor. To reduce the effects of drift and residuals at very low levels, the d.c. output voltage of the sensor is applied to a solid state chopper, which converts the d.c. voltage to a 94 Hz square wave with an amplitude proportional to the d.c. voltage. The drive signals for the chopper are provided from the analog section.

The analog section provides amplification, ranging, and demodulation of the 94-Hz square-wave signal supplied from the chopper. Ranging is performed manually by means of eight pushbuttons on the front panel; remote ranging is available by means of rear panel programming connectors. The analog section also receives a 752 Hz clock signal from the clock section; the chopper and demodulator drive signals are derived from this clock signal by frequency divider circuits in the analog section. The d.c. output voltage of the analog section is supplied to the shaping section, where the amplified and demodulated d.c. voltage is converted to a linear voltage used for driving the meter and the analog output. (As noted in §1.2E, the probe's output is inherently non-linear before shaping; it is true r.m.s. on the lower ranges, and peak-to-peak on the higher ranges.)

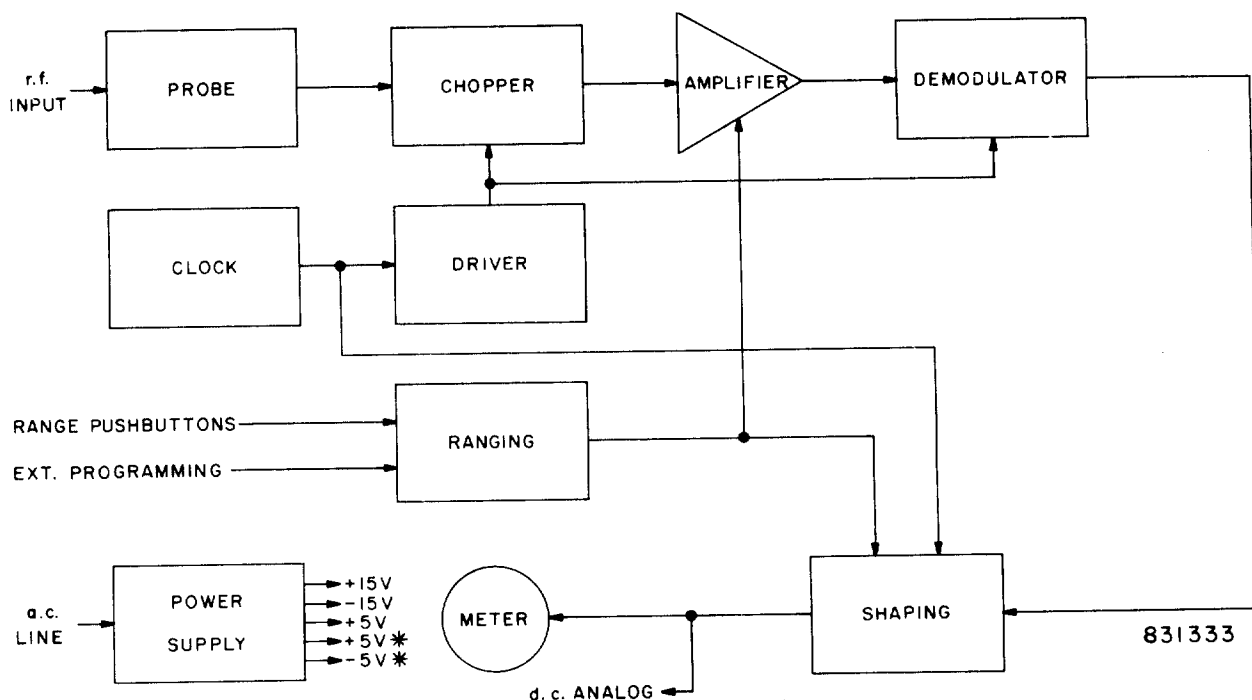

Figure 3-1. Simplified Block Diagram

Operating power for the Model 92E circuits is provided by the power supply. Line voltages of 100, 120, 220, or 240 volts,  $\pm 10\%$ , may be applied to the power transformer. Switches on the rear panel of the instrument allow the switching of primary winding connections in order to accommodate the various input voltages. The secondary windings of the power transformer furnish power to rectifier regulator circuits that develop regulated +5, -5, +15, and -15 volts for operation of the other circuits in the instrument.

### 3-2. CIRCUITS: DETAILED DISCUSSION

In the following paragraphs the circuits of the 92E are grouped by function as follows: Sensor, Analog (includes Chopper, Amplifier, Demodulator and Driver), Clock, Ranging, Shaping, and Power Supply. (Refer to Figure 3-1.)

A. Sensor. The r.f. probes used with the 92E are unterminated, high input-impedance devices. The r.f. voltage applied to the probes is rectified by a full-wave detector employing factory selected diodes with special characteristics, including low capacitance and controlled thermal offsets. The resulting d.c. voltage is a function of the applied r.f. voltage.

A full-wave detector, unlike a single diode detector, permits measurement of highly asymmetrical waveforms without substantial error. When a voltage of such waveform is impressed on a single diode detector circuit, whether or not the portion of the waveform that "turns on" the diode is restricted to the square law region of the diode's characteristic, the recovered d.c. voltage is dependent upon the phase of the input voltage. Consider a positive pulse of low duty cycle applied to the anode of a diode detector. The recovered d.c. voltage is a function of the polarity, amplitude, and duration of the pulse. If the pulse is inverted, it drives the diode into a reverse bias condition and the recovered d.c. voltage is near zero. A full-wave detector circuit, on the other hand, yields an equal amount of d.c. irrespective of the polarity of the input pulse. The r.m.s. voltage of a pulse obviously does not depend upon the phase of the pulse. The response of a single diode detector, square law characteristic notwithstanding, cannot reflect this; a full-wave detector circuit does.

Probe response is true r.m.s. for inputs below 30 mV. Above this voltage level, the probe response gradually changes, approaching peak-to-peak at the higher levels. However, the voltage data is digitally shaped in the 92E to indicate r.m.s. voltage, provided that the input is reasonably sinusoidal, as is the case with c.w. and f.m. signals.

The probe body has been designed to minimize noise. The probe connects to the 92E through a low noise cable.

B. Chopper. The chopper board contains four solid state switches, which are used to convert input d.c. voltage to a 94 Hz square wave. The switches are controlled by 94-Hz chopper drive signals supplied from a frequency divider chain in the analog section. Potentiometers A4R4 and A4R5 provide means for adjusting the chopper to zero output with zero input. Use of a solid state chopper eliminates most of the undesirable characteristics of electromechanical choppers (e.g.: contact wear, bounce, and contamination). The output of the chopper is a balanced 94 Hz square wave that is directly proportional to the d.c. voltage applied from the sensor.

C. Amplifier. (See Figure 3-2.) The balanced 94 Hz square wave signal from the chopper is amplified by operational amplifiers A2U6, A2U8, A2U10a and A2U10b. The gain of the operational amplifiers A2U6, A2U8 and A2U10a is controlled by adjusting feedback to the amplifier through multiplexer A2U7 and a resistor network. The signals R0, R1 and R2, from the ranging section, applied through gates A2U9a and A2U9b, control the switching of input terminals D1 and D2 of multiplexer A2U7 to two of eight points in the resistance networks, thereby adjusting the feedback and the amplifier gain.

The 94 Hz output of op amps A2U6 and A2U8 is applied to the differential inputs of op amp A2U10a, which makes the signal single ended. This signal is amplified by op amp A2U10b and associated circuitry. Multiplexer A2U11 adjusts the gain of this op amp in eight steps, under control of signals R0, R1 and R2 from the ranging section, to provide decade ranging in voltage. The nominal output for a full scale input on each range is four volts, approximately, peak-to-peak (at TP8). Separate potentiometers are provided for full scale calibration of the instrument on each range. A2R72 is the Master Gain Control and A2R73 is used to adjust for any large differences in the efficiency of probes.

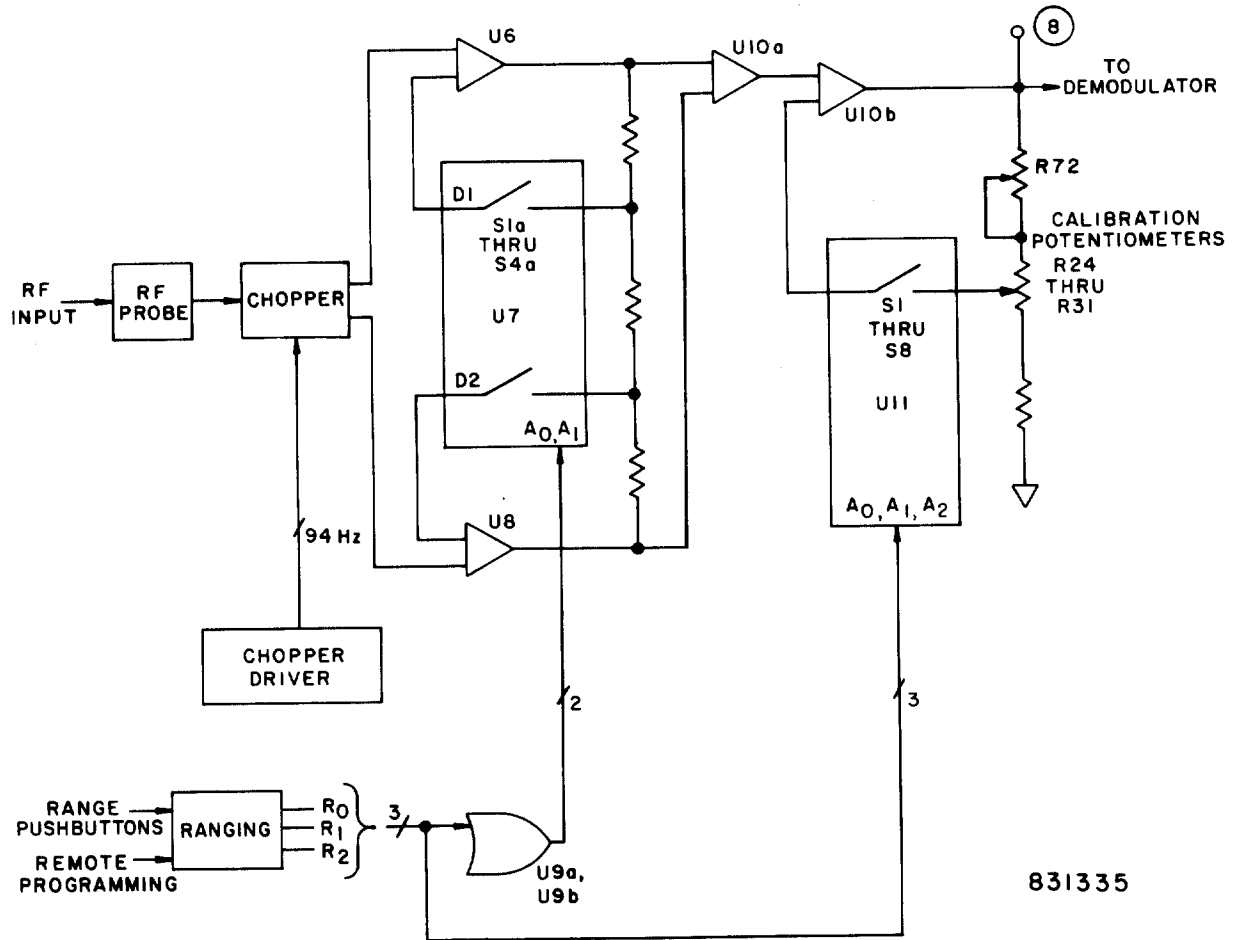

Figure 3-2. Block Diagram: Amplifier Section

D. Demodulator. A solid state demodulator, consisting of switches A2U12a and A2U12b, converts the amplified and scaled 94 Hz square wave signal back to d.c. The demodulator is driven by a 94 Hz demodulator drive signal, which is synchronized with the 94 Hz chopper drive signal. A synchronous, sampling type demodulator circuit is used, with the sample being taken at a point well removed from the chopper switching points. The demodulator is followed by the high input impedance buffer A2U26c to reduce loading of the sampling capacitor A2C16 to negligible proportions. Output d.c. is supplied to A2U24c in the shaping section. (See Figure 3-3.)

E. Driver. Chopper and demodulator drive signals are derived from a 752 Hz signal supplied from the clock circuit (see §3-2F). A2Q1 shifts the clock voltage from the zero to plus five volt level (used by the shaping circuitry), to a plus five and minus five volt level used by the chopper circuitry. Flip-flops A2U14a, A2U14b, A2U16a and A2U16b divide down the 752 Hz signal to 94 Hz, and gates A2U13a, A2U13b and A2U13c shape the 94 Hz demodulator signal. Figure 3-3 shows the derivation of the chopper and demodulator drive signals from the 752 Hz clock signal.

F. Clock. A crystal controlled oscillator (A2U19a, b, c, and crystal Y1), provides 96 kHz clock pulses. This 96 kHz square wave is frequency divided in the binary counter A2U20 to produce clock signals for both the analog and the shaping circuitry. (See Figure 3-4.)

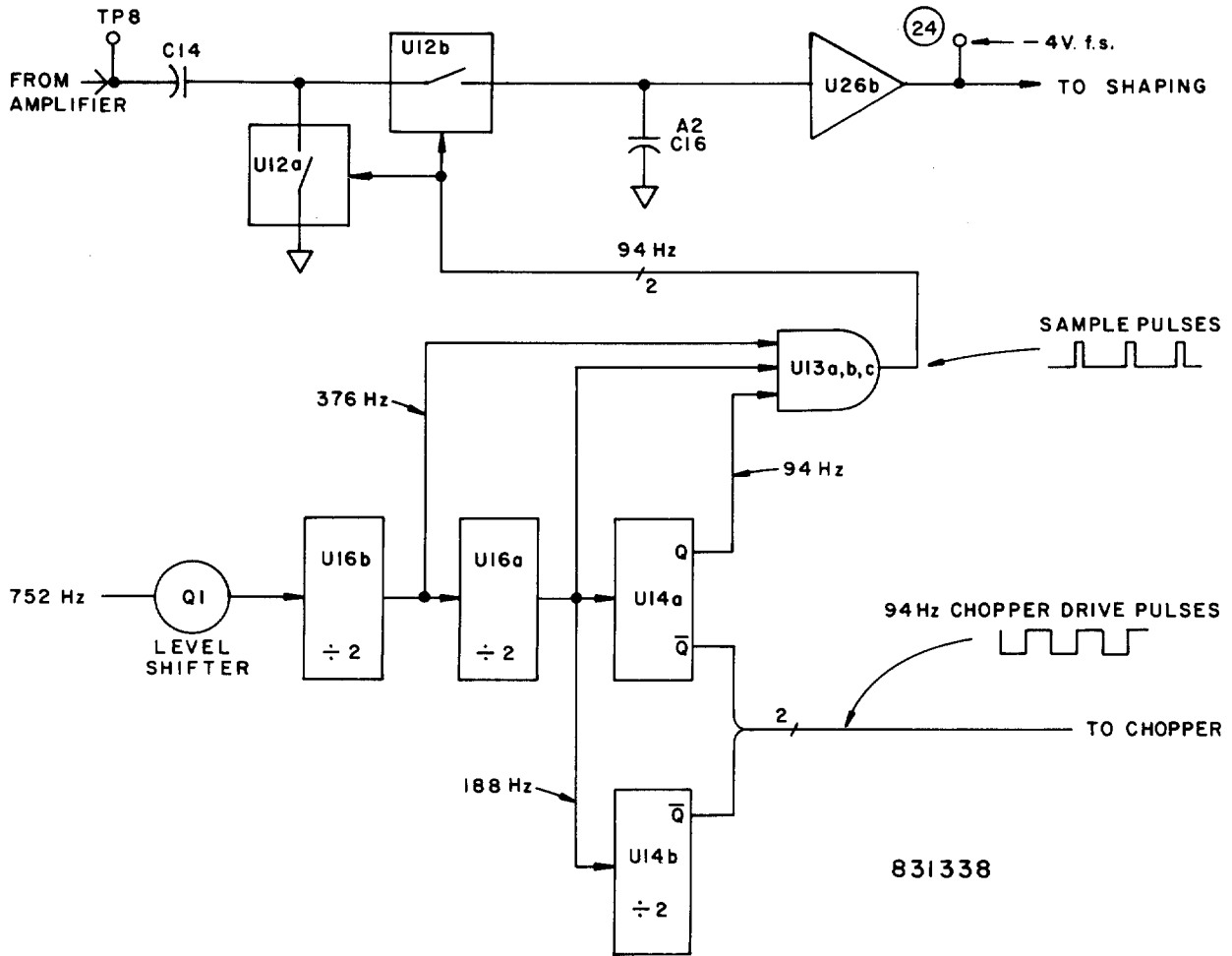
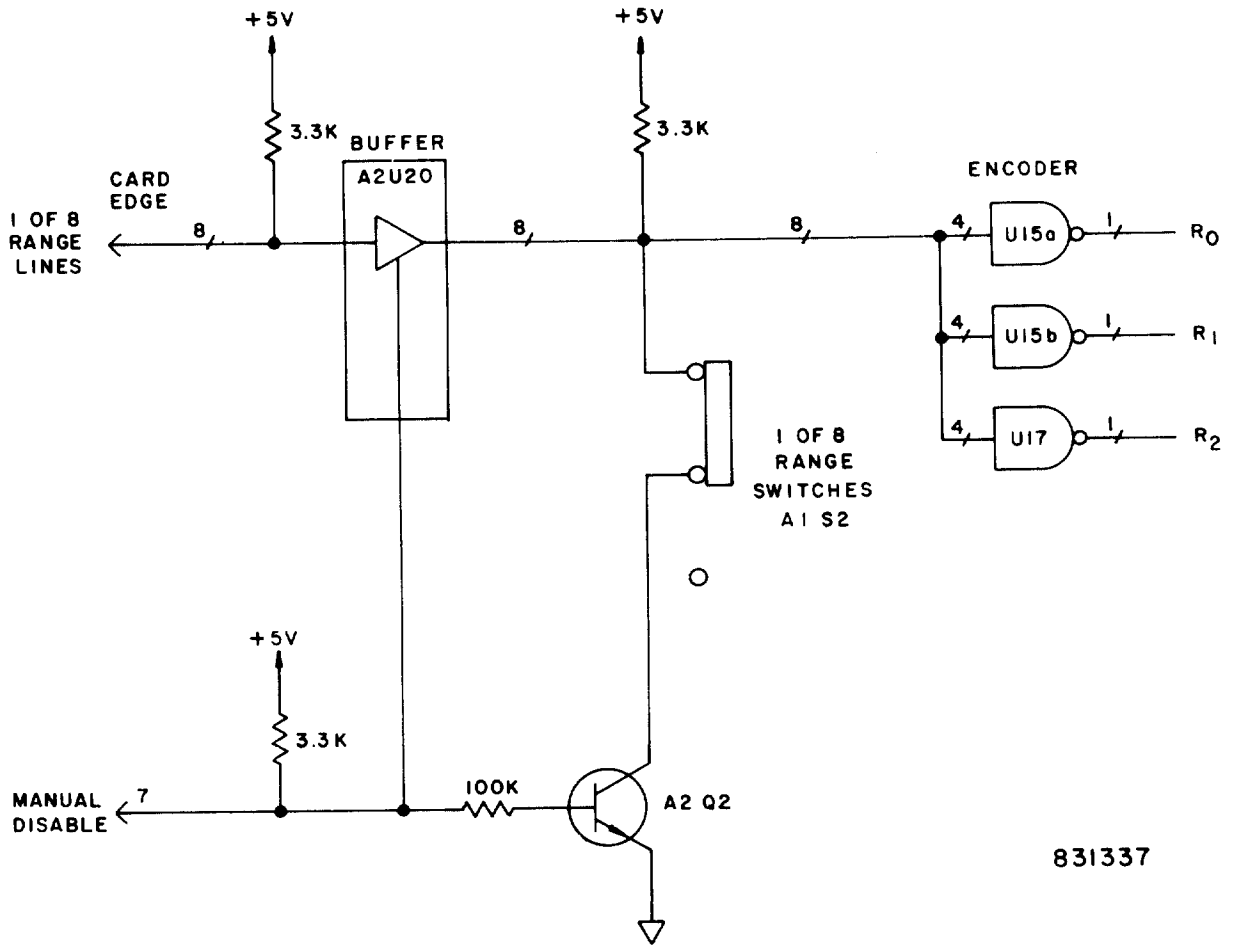

Figure 3-3. Block Diagram: Demodulator and Driver

G. Ranging and Programming. Ranging of the 92E is performed manually by means of the eight pushbutton switches on the front panel. When a range is selected, one section of ALS2 "shorts" to ground inputs to the range encoder. The range encoder comprises A2U15a, A2U15b, and A2U18, and will generate a binary range code on lines R0, R1 and R2. This range code is used by both the amplifier circuitry and the shaping circuitry to select the appropriate signal processing. (See Figure 3-4.)

Remote programming is accomplished by simultaneously shorting to common the Manual Disable and the appropriate range lines on the card edge connector located at the rear of the 92E. Shorting the Manual Disable line turns off A2O2, causing the latter to disconnect the front panel switches. Shorting the Manual Disable line also enables buffer A2U18, allowing it to transmit ranging information from the card edge connector to the range encoder.

H. Shaping. Shaping is used to linearize the output of the diode sensor. (The conversion of r.f. to d.c. in the sensor is virtually square law for the lowest ranges, gradually becoming quasi-linear at three volts.) The shaping circuit of the 92E uses data stored in ROM A2U22, and a dual slope integrator, to linearize the output of the sensor.



831337

Figure 3-4. Block Diagram: Ranging Circuitry

Shaping is achieved in four phases. Phase 0 integrates the input signal. Phase 1 combines the input with the shaping data. Phase 2 samples and holds the shaped and corrected output. Phase 3 resets the circuit for another cycle. The phases are controlled by the output of demultiplexer A2U21. (See Figure 3-5.)

1. Phase 0 occurs when  $\overline{Q0}$  of the demultiplexer A2U21 is low. During this phase, the d.c. voltage from the demodulator is applied to the integrator A2U10d through switch A2U24c. The integrator output starts at zero before ramping to its final value. (A voltage of -4 at TP24 will cause the integrator output voltage at TP25 to be approximately +5 volts at the end of Phase 0.)

Comparator A2U29 measures the polarity of the integrator at TP25 and gives an output of either 0 V or 5 V for a negative or a positive integration, respectively. The polarity information is stored in flip-flop A2U30a and is used to determine the polarity of the voltage reference at pin 1 of A2U26a. A2U23 is a stable voltage source. A2U24a and A2U24b are switches that configure amplifier A2U26a as either non-inverting or inverting, thus changing from (+) to (-) the polarity of the voltage derived from the reference.



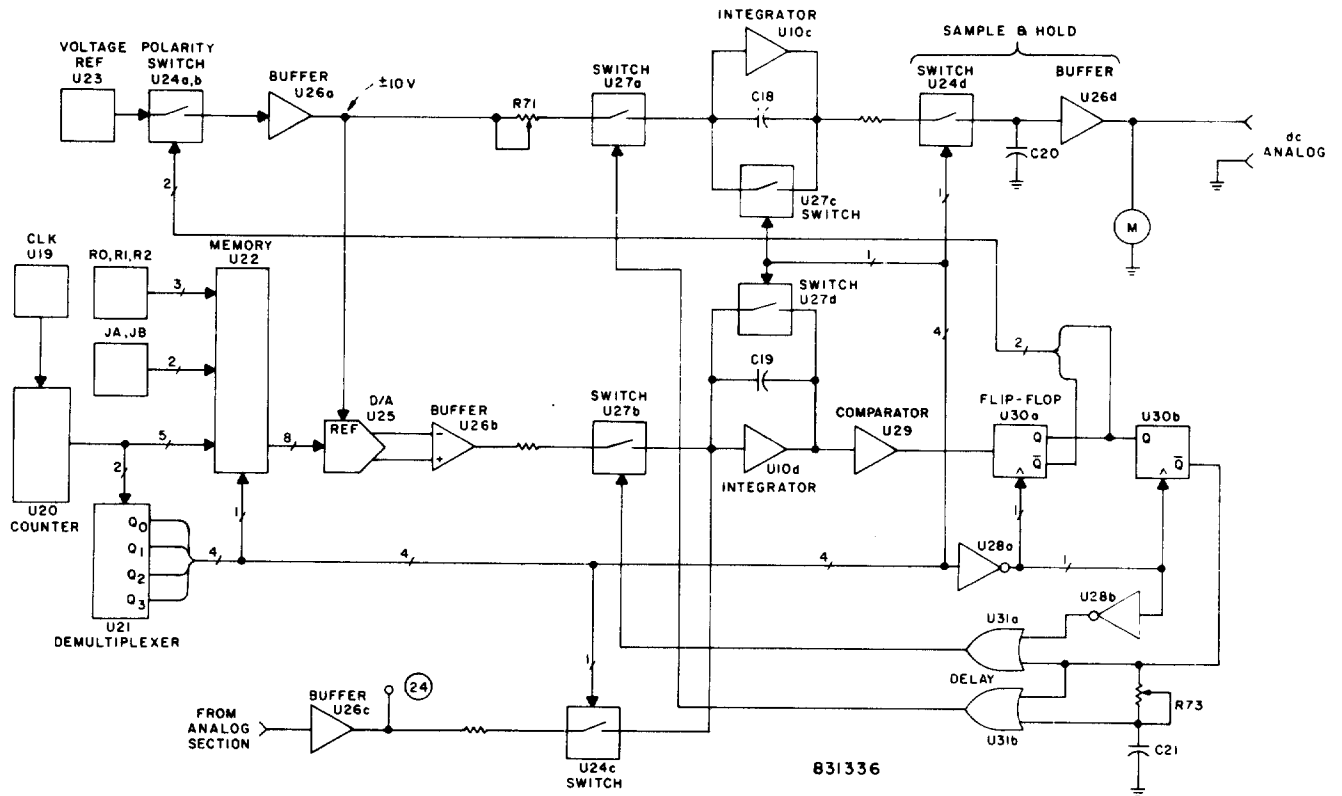

Figure 3-5. Block Diagram: Shaping Section

§3-2H, Continued.

2. Phase 1 occurs when  $\overline{Q1}$  of the A2U21 demultiplexer is low. This signal is inverted in A2U28a to provide a clock to the flip-flops A2U30a and A2U30b. The clock latches the polarity information into A2U30a and also sets Q2 of A2U30b low.

The Phase 1 signal addresses ROM A2U22. The ROM is addressed also by R0, R1 and R2 (the range lines, which set shaping appropriate to the range currently in use), and by JA and JB (the shaping jumpers, which program for variations in sensor shaping). ROM A2U22 also receives signals in a binary sequence from counter A2U20. Shaping data stored in the ROM are recalled and converted in DAC A2U25 into the shaping signal. The shaping signal is of the opposite polarity to the input signal. Closing switch A2U27b allows the shaping signal and the input signal to combine in the integrator. (A2U27b is closed by the Phase 1 signal "or-gated" with the output of A2U30b.)

As just noted, the shaping signal and the input signal are of opposite polarity. The integrator therefore ramps toward zero volts at a rate proportional to the shaping signal's amplitude.

Phase 1 closes switch A2U27a, allowing the reference voltage to be integrated in A2U10c, the output integrator. The output integrator provides a shaped signal that drives the meter and the d.c. analog output by way of A2U26d (a high impedance unity gain buffer). The time constant of A2R69 & A2C21 delays the closing of switch A2U27a in order to mask the noise caused by the shaping process when there is zero input. A2R71 adjust for the tolerance of the integrator capacitor.

During Phase 1 the comparator A2U29 detects the zero crossing of the integrator. When the zero crossing is detected, the output integrator switch A2U27a is opened, halting the integrator A2U10c at a voltage proportional to the sum of the shaping and the input voltages. The output of the comparator, and the output of the comparator flip-flop, are "exclusive or-ed" in A2U28b. This signal resets flip-flop A2U30b, opening both switches A2U27a and A2U27b.

3. During Phase 2, the  $\overline{Q2}$  output of demultiplexer A2U21 closes switch A2U24d. This samples the output of integrator A2U10c and holds the voltage in A2C20.
4. The  $\overline{Q3}$  output of demultiplexer A2U21 closes switches A2U27c and A2U27d during Phase 3. These switches discharge their respective integrator capacitors, leaving the integrators ready for another shaping cycle.

#### I. Power Supply.

The power supply circuits provide d.c. operating power for all other circuits of the 92E. Regulated output voltages of +15, -15, +5, and -5 volts are supplied. Line voltages of 100, 120, 220 and 240 volts,  $\pm 10\%$ , 50 to 400 Hz, can be accommodated.

A.C. power is applied to the primary windings of power transformer A1T1 through the LINE switch A1S2, and the two section line voltage switch A1S1. The latter changes the transformer primary winding connections as required to accommodate the available line voltage. Fuse A1F1 protects the power-supply circuits against overload. The voltages developed in the secondary windings of the power transformer are applied to three rectifier regulator circuits on the main printed circuit board A2. (See Figure 3-6.)

The +15 V and -15 V supplies are similar. Input to each supply consists of 20 V, supplied by a separate secondary winding of the power transformer. In each supply, the applied a.c. is rectified by the bridge rectifier A2CR1, filtered by A2C1 and A2C2, and then regulated by A2U1 and A2U2.

Regulated +5 V\* and -5 V\* operating supplies for the chopper and analog circuits of the 92E derive power from the regulated +15 V and the -15 V supplies, using regulators A2U4 and A2U5. Thus, the supplies for these more sensitive circuits are isolated from the less sensitive circuits.

Regulated +5 V for the digital circuits is provided by a separate 5 V d.c. supply, powered by the third secondary winding of the power transformer. This further isolates the sensitive input circuitry from noise caused by the digital circuitry. The applied a.c. is rectified by the bridge rectifier A2CR2 to develop 11 V d.c., at A2C3. This filtered d.c. is converted to +5 V by regulator A2U3.

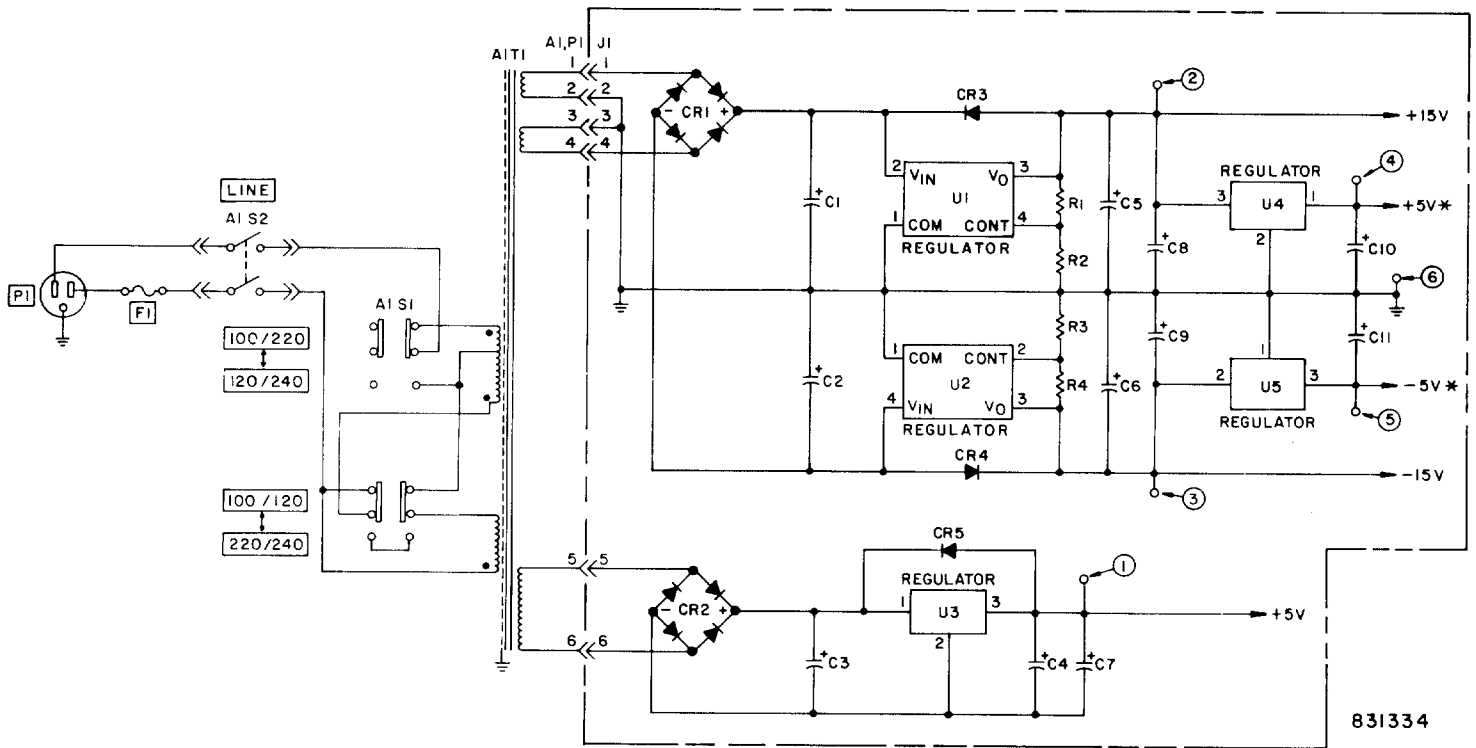

Figure 3-6. Block Diagram: Power Supply

## SECTION IV

### MAINTENANCE

#### 4-1. INTRODUCTION

Values and tolerances shown in this section are not specifications but are provided only as guides to the maintenance and calibration of the 92E.

#### 4-2. PERIODIC CALIBRATION

The Model 92E is designed to provide trouble free operation over extended periods of time. However, as with any precision instrument, the 92E should be checked periodically to verify proper calibration. To make such calibration checks, the following equipment is required:

A. A reliable signal source of 200 kHz - 1 MHz with less than 1% distortion at levels up to 3 volts across 50 ohms. The Boonton Model 26A R.F. Millivoltmeter Calibrator is suggested; this calibrator provides 1 MHz voltages from 60  $\mu$ V to 3 V with an uncertainty of  $< \pm 0.5\%$  of indication. Full scale voltages in a 1-3-10 sequence can be switch selected. On any range incremental voltages can also be selected in 10% f.s. steps.

B. A precision voltmeter such as the Ballantine 310A or 300H, the Boonton Electronics Model 93A or 93AD, or the Hewlett Packard Model 400D or 400H, or equivalent.

C. A precision d.c. voltmeter capable of measuring  $\pm 15.0$  V, accurate to 0.25% or better.

#### 4-3. POWER-SUPPLY CHECKS

Improper operation of the 92E may be caused by incorrect d.c. operating voltages. Before any calibration, adjustments or troubleshooting, perform the power supply checks listed below. Refer to parts location diagram at the rear of this manual.

**WARNING**

Line voltages up to 240 volts, a.c., may be encountered in the power supply circuits. To protect against electrical shock, observe suitable precautions when connecting and disconnecting test equipment, and when making voltage measurements.

The power supply test points, and the d.c. voltage to be expected at each test point, are as follows.

A. A2TP1, +5 V,  $\pm 5\%$ .

B. A2TP2, +15 V,  $\pm 5\%$ .

C. A2TP3, -5 V,  $\pm 5\%$ .

D. A2TP4, +5 V,  $\pm 5\%$ .

E. A2TP5, -5 V,  $\pm 5\%$ .

#### 4-4. CALIBRATION CHECK

When checking the calibration of an instrument having the sensitivity and bandwidth of the Model 92E, it is essential to take precautions against errors resulting from stray pick-up voltages (see §2-5H). A well shielded signal source must be used in conjunction with coaxial connections to both the Model 92E and the standard reference meter. Even with a well shielded generator and connections, it is sometimes possible for the reference meter to pick up stray r.f. signals and feed them into the probe. It is advis-

§4-4, Continued.

able to test for this condition by disconnecting the standard meter and noting any change in level.

Using the equipment listed in §4-2, check the calibration of the Model 92E on each range using a test voltage equal to the full scale value. If the check reveals that recalibration is required, the procedure outlined in §4-5 should be followed.

**4-5. CALIBRATION PROCEDURE**

The Model 92E should be calibrated at room temperature (23°C) after a minimum warm up time of five minutes. Note, however, the longer warm-up time required for the chopper adjustments. Refer to Figure 4-1.

A. Chopper Adjustments. These adjustments require that the 92E be turned on for not less than one hour and the 92E and its sensor be at an ambient temperature of 21°C to 25°C.

1. In the 92E, remove the "zero" potentiometer connector, A1P1.
2. Connect the sensor to the adjustable signal source and set the output of the source to zero.
3. Set the two chopper adjustments, A4R4 and A4R5, to their physical midpoints.
4. Connect the precision voltmeter to TP24 and note the indication.
5. Adjust A4R4 to decrease the voltmeter's indication to one half of that in Step 4.
6. Adjust A4R5 to bring the indication to zero. There will be some fluctuation of the indication and averaging will be required.
7. Re-connect the "zero" potentiometer connector, A1P1.

B. Delay Adjustment.

1. Adjust A2R73 so that the falling edge of the square wave at TP29 is delayed 165 ms with respect to the falling edge of the square wave at TP30.

C. Zeroing Adjustments.

1. Turn the instrument "off" for at least one minute. If the meter pointer does not come to rest at zero, use the zero adjustment screw in the lower center of the meter to bring the pointer to zero. Turn the 92E "on"; be sure that the 92E has stabilized at room temperature at least five minutes before the following calibration is performed.

2. Set the 92E's FULL SCALE range selector to the 1 mV range and zero the instrument as described in §2-5E.

D. Master Gain Adjustments.

1. Set A2R72 to the midpoint of its range.
2. Set the FULL SCALE range selector to the 1 mV range, apply 1.000 mV input and adjust A2R27 for -4.00 V at TP24.
3. Set the FULL SCALE range selector to the 3 mV range, zero the instrument as described in §2-5E, apply 3.000 mV input, and adjust A2R26 for -4.00 V at TP24.

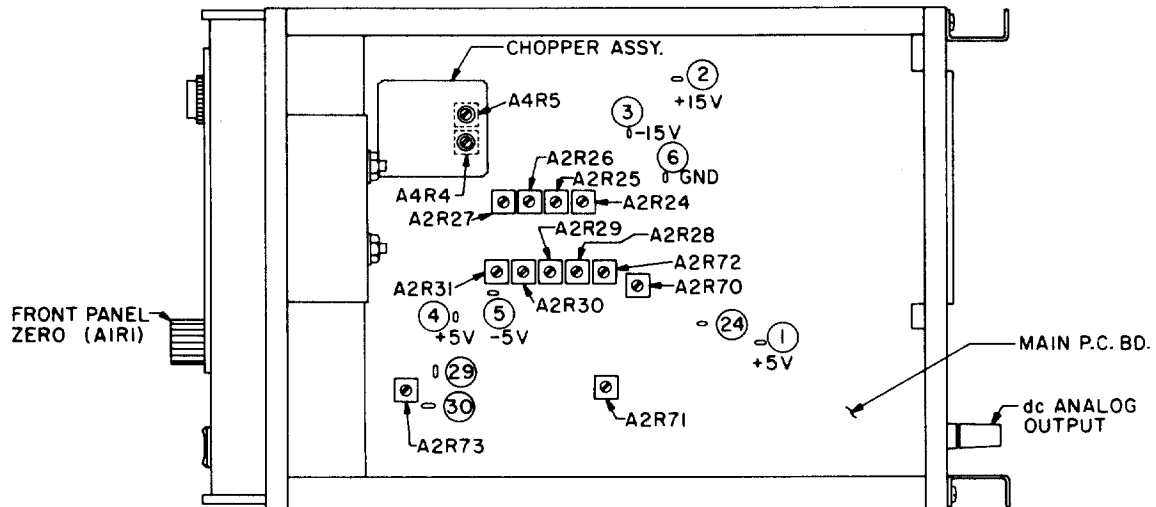

831340

ADJ NO	CONT	FUNCTION	RANGE	INPUT $\pm 0.2\%$	ADJUST	
1	A4R4 A4R5	CHOPPER ADJ	1 mV	0	AVERAGE OF ZERO Vdc @ (24)	
2	A2R73	DELAY ADJ	1000 mV	1000mV	165 $\mu$ s @ (29) FROM (30)	
3	AIRI	FRONT PANEL ZERO	1 mV	0	AVERAGE ZERO INDICATION	
4	A2R72	MASTER GAIN ADJ	—	—	4.00V AT (24)	
5	A2R27	RANGE ADJ	1 mV	1 mV		
6	A2R26	RANGE ADJ	3 mV	3 mV		
7	A2R25	RANGE ADJ	10 mV	10 mV		
8	A2R24	RANGE ADJ	30 mV	30 mV		
9	A2R31	RANGE ADJ	100 mV	100 mV		
10	A2R30	RANGE ADJ	300 mV	300 mV		
11	A2R70	METER FS ADJ	1000 mV	1000mV		
12	A2R28	RANGE ADJ	3000 mV	3000mV		
13	A2R71	OUTPUT INTERGRATOR ADJ	1000 mV	1000mV		WITH 4.00V @ (24) ADJUST dc ANALOG FOR 10.00V
14	A2R29	RANGE ADJ	1000 mV	1000mV		+10.00V AT dc ANALOG TERMINALS DC VOLTMETER INPUT $> 10$ M OHMS
15	A2R70	METER FS ADJ	1000 mV	1000mV		1000 mV INDICATION
16	A2R28	RANGE ADJ	3000 mV	3000mV	3000 mV INDICATION	
17	A2R27	RANGE ADJ	1 mV	1 mV	1.000 mV INDICATION	
18	A2R26	RANGE ADJ	3 mV	3 mV	3.000 mV INDICATION	
19	A2R25	RANGE ADJ	10 mV	10 mV	10.00 mV INDICATION	
20	A2R24	RANGE ADJ	30 mV	30 mV	30.00 mV INDICATION	
21	A2R31	RANGE ADJ	100 mV	100 mV	100.0 mV INDICATION	
22	A2R30	RANGE ADJ	300 mV	300 mV	300.0 mV INDICATION	

Figure 4-1. Adjustment Locations and Descriptions

§4-5, Continued.

4. Set the FULL SCALE range selector to the 10 mV range, zero the instrument as described in §2-5E, apply 10.00 mV input, and adjust A2R25 for -4.00 V at TP24.

5. Set the FULL SCALE range selector to the 30 mV range, apply 30.00 mV input, and adjust A2R24 for -4.00 V at TP24.

6. Set the FULL SCALE range selector to the 100 mV range, apply 100.0 mV input, and adjust A2R31 for -4.00 V at TP24.

7. Set the FULL SCALE range selector to the 300 mV range, apply 300.0 mV input, and adjust A2R30 for -4.00 V at TP24.

8. Set the FULL SCALE range selector to the 1000 mV range, apply 1000 mV input, and adjust A2R29 for -4.00 V at TP24.

9. Set the FULL SCALE range selector to the 3000 mV range, apply 3000 mV input, and adjust A2R28 for -4.00 V at TP24.

E. Output Integrator Adjustments.

1. Set the FULL SCALE range selector to the 1000 mV range, apply 1000 mV input and check for  $-4.00 \pm .10$  V at TP24. If the reading is not within tolerance repeat §4-5D. If the reading is within tolerance perform step 2.

2. Adjust A2R71 for 10.00 V at the D.C. ANALOG output.

F. Range Adjustments.

1. Set the FULL SCALE range selector to the 1000 mV range and apply 1000 mV input, adjust A2R29 for +10.00 V at the D.C. ANALOG terminals.

2. Set the FULL SCALE range selector to the 1000 mV range and apply 1000 mV input, observe the panel meter and adjust A2R70 for 1000 mV.

3. Set the FULL SCALE range selector to the 3000 mV range and apply 3000 mV input, observe the panel meter and adjust A2R28 for 3000 mV.

4. Set the FULL SCALE range selector to the 1 mV range, zero the instrument as described in §2-5E, apply 1.00 mV input, observe the panel meter and adjust A2R27 for 1.00 mV.

5. Set the FULL SCALE range selector to the 3 mV range, zero the instrument as described in §2-5E, apply 3.00 mV, observe the panel meter and adjust A2R26 for 3.00 mV.

6. Set the FULL SCALE range selector to the 10 mV range, zero the instrument as described in §2-5E, apply 10.00 mV, observe the panel meter and adjust A2R25 for 10.00 mV.

7. Set the FULL SCALE range selector to the 30 mV range, apply 30.00 mV input, observe the panel meter and adjust A2R24 for 30.00 mV.

8. Set the FULL SCALE range selector to the 100 mV range, apply 100.0 mV input, observe the panel meter and adjust A2R31 for 100.0 mV.

9. Set the FULL SCALE range selector to the 300 mV range, apply 300.0 mV input, observe the panel meter and adjust A2R30 for 300.0 mV.

#### 4-6. TROUBLESHOOTING

The following troubleshooting procedures describe the instrument's cover removal, probe replacement, and probe s.w.r. and frequency tests. The test points, waveforms, and related test-voltages are shown on the schematic diagrams (see Section VI).

A. Cover Removal. The instrument's cover is removed from the case by removing the screw on top of the case.

B. Replacement of R.F. Probes. The serial number of the 92E matches that of the R.F. Probe with which it was calibrated at the factory. If it is necessary to change probes for any reason, the instrument's calibration MUST be rechecked. In most cases, full recalibration (see §4.5) will be required. Similarly, if the R.F. Probe supplied with the 92E is exchanged for a Low Frequency Probe, recalibration will be required. (See §2-7.)

C. Probe Tests. The probe and accessories furnished with the 92E can be checked for s.w.r. and frequency response by following the procedures detailed in the paragraphs below. Should a probe exhibit out of tolerance performance in these tests, the user is urged not to attempt repair but to send the probe back to the factory for repair or replacement.

##### 1. S.W.R. Measurement.

###### a. Test Equipment

- i. Generator for the desired frequency range. For example:  
125 kHz - 175 MHz, Boonton Electronics Model 103D;  
450 kHz - 1040 MHz, Boonton Electronics Model 102F-20;  
10 MHz - 1400 MHz, Hewlett-Packard Model 8660 A/C
- ii. Slotted line: GR Type 900 LB
- iii. Detector: GR Type 1241, or Boonton Model 92E.

###### b. Test Procedure

- i. Connect the slotted line to a proper signal source, and terminate the line with the device to be tested, i.e., Boonton Model 952003-01A Tee Adapter and Boonton Model 952028-01A 50  $\Omega$  Termination, or Boonton Model 952002-01A 50  $\Omega$  Adapter.

The probe and R.F. Millivoltmeter must be connected to the accessory being tested. The probe supplies a perturbation for which the accessory was designed, and which it needs, to meet its specification. The millivoltmeter permits the test level to be set to the desired value.

- ii. Move the carriage of the slotted line to a point of minimum voltage, then to a point of maximum voltage, and record the values.
- iii. The s.w.r. is the ratio of the maximum and the minimum voltages. The measurement can be repeated at other frequencies and levels, as required.



2. Frequency Response. The most accurate method of measuring the frequency response of the R.F. Probe for the 92E is through the use of micro-potentiometers, electrothermic a.c.- d.c. transfer instruments, and A-T (attenuator-thermoelement) voltmeters. Users who have these instruments available will be familiar with their application.

A method of accuracy compatible with that of the Model 92E uses a point-by-point frequency scan in conjunction with a power splitter and calibrated power meter. The method is detailed in the following paragraphs.

a. Test Equipment

- i. Signal source for the frequency range of 10 to 1200 MHz. Suggested instruments are Wavetek 2001 or H-P 8660 A/C. In this application, the generator is manually swept.
- ii. Power Splitter: Weinschel Model 1870A, or H-P 11667A.
- iii. Calibrated R.F. Power Meter: Boonton 42B, or H-P 435A.

b. Test Procedure

- i. Connect the equipment as shown in Figure 4-2.

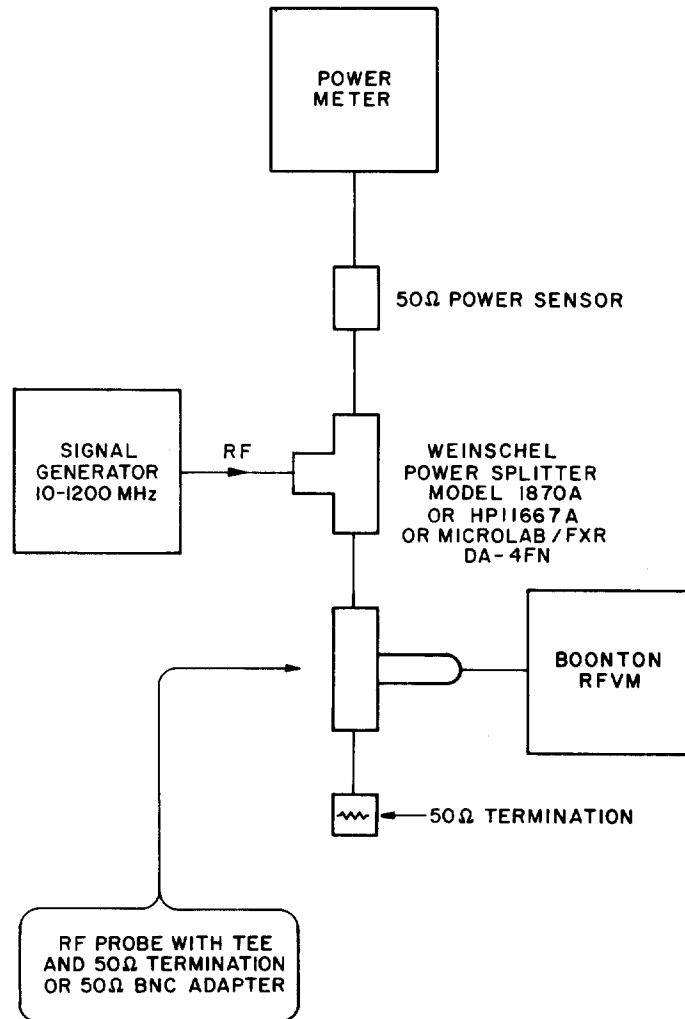

830917

Figure 4-2. Frequency Response Test Setup

§4-6C2b, Continued.

- ii. Set the frequency of the generator to 10 MHz, and adjust the output control for the desired test level. If the response is to be measured at one level only, a test voltage of 100 or 200 mV is recommended.
- iii. Disable the output of the generator momentarily and zero the power meter. Re-establish the output level and note the reading on the power meter. Record the frequency of the generator and the reading of the 92E. Change the frequency, in whatever increments are desired, through the range of 10 to 1200 MHz, holding the reference reading on the power meter constant.
- iv. Reverse the output ports of the power splitter and repeat Step iii.
- v. The correct voltmeter reading is obtained at each frequency by averaging the two readings. This virtually eliminates the influence of frequency differences of the two ports of the power divider.
- vi. Further refinements can be made by filtering the output of the generator, and measuring the complex reflection coefficients of the power meter, r.f. millivoltmeter accessory under test, and all ports of the power divider. The usual corrections can then be made. These procedures are not usually necessary, and should be done only if the additional accuracy is warranted.

3. Swept Frequency Response and S.W.R. Another method of measuring both the frequency response and the s.w.r. (in terms of the reflection coefficient), but with somewhat reduced accuracy, employs a sweep generator, external levelling of the generator, an s.w.r. bridge, a power splitter, and a sensitive oscilloscope.

a. Test Equipment

- i. Sweep Generator: Wavetek 2001 or H-P 8660 A/C; frequency range 0.01 to 2600 MHz.
- ii. S.W.R. Autotester: Wiltron Model 63NF50.
- iii. Oscilloscope: Tektronix Model 5110, with two Model 5A20 Vertical Amplifiers.
- iv. Power Splitter: Weinschel Model 1870A, or H-P 11667A.
- v. Standard 1.2:1 Mismatch Termination: Weinshel M1410-1.2

b. Test Procedure

- i. Connect the equipment as shown in Figure 4-3, and temporarily connect the probe under test to the 92E. Adjust the output control of the sweep generator for a reading on the 92E of 100 mV at a fixed frequency of 100 MHz.
- ii. Calibrate one of the scope's vertical-input amplifiers for a sensitivity of 100  $\mu$ V/div. The other vertical amplifier should be calibrated so that a change from 100 mV to 90 mV applied to the input of the probe under test will produce a vertical deflection of two divisions. This can be done easily if a Boonton Electronics 26A R.F. Millivoltmeter Calibrator is available. The probe should be temporarily connected to the output of the calibrator while output levels of 100 mV and 90 mV are alternately selected, and

the sensitivity of the second input amplifier is adjusted for a deflection of two divisions.

- iii. Substitute the Standard 1.2:1 Mismatch Termination for the accessory under test, and calibrate the graticule of the oscilloscope for an s.w.r. of 1.2. Replace the accessory and probe.
- iv. Adjust the limits on the three bands of the sweep generator for coverage from 10 to 1200 MHz. Study the traces for both frequency response and s.w.r. (return loss).
- v. Reverse the output ports of the power splitter and repeat Steps (iii) and (iv).
- vi. Note that the permissible error for the frequency-response trace expands with frequency. For meaningful results, the graticule should be marked with a grease pencil, showing maximum permissible errors for the various frequency bands as determined with a calibrated signal of, say, 1 MHz, and at levels above and below the selected test level. Note also that the recovered d.c. from the r.f. probe, which is applied to the second vertical amplifier, will vary as the square of the r.f. input level for test levels of 30 mV or less. Above 30 mV, the r.f. to d.c. conversion gradually changes from square law to linear, and approaches a peak-to-peak rectifier at an input of 3 volts.

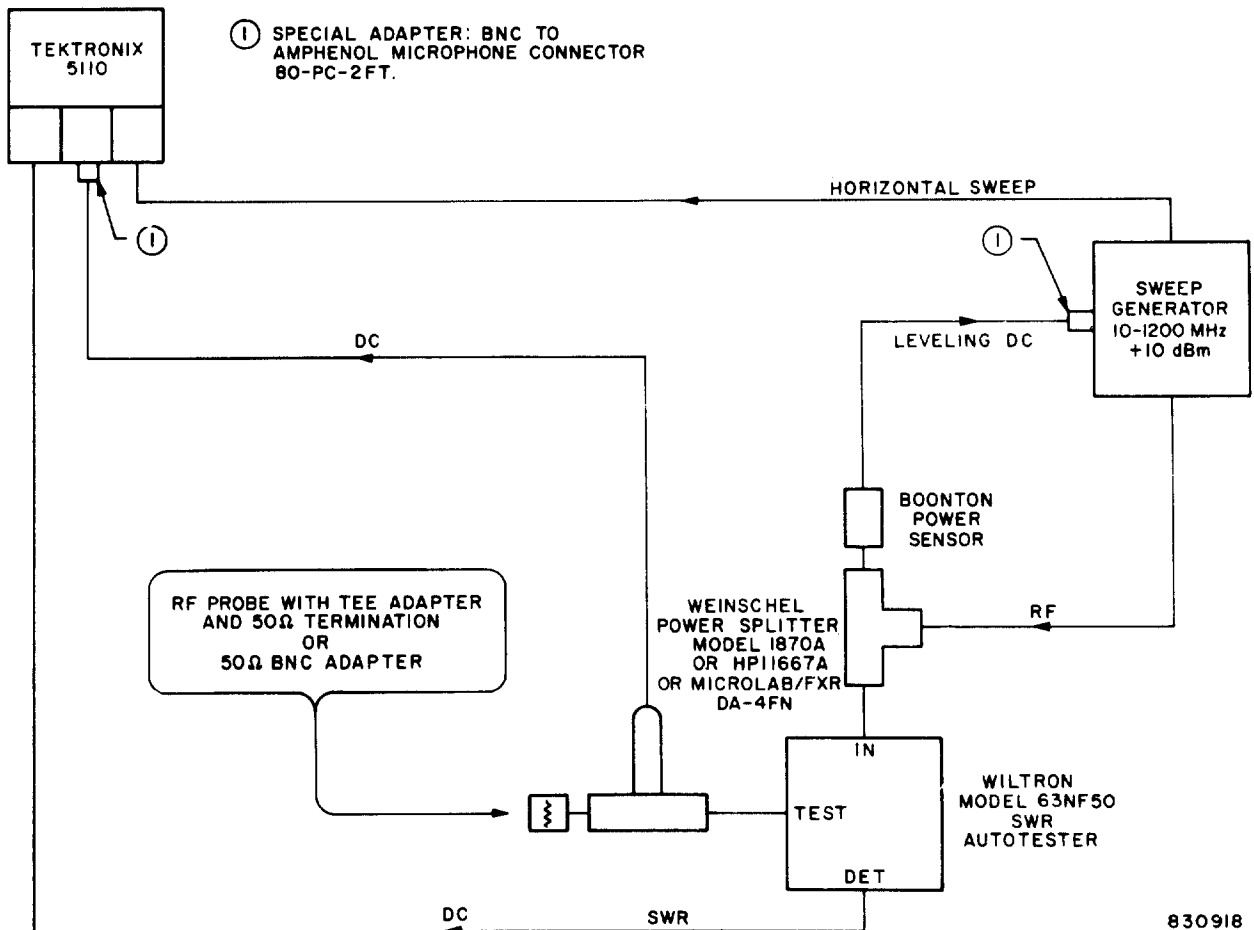

Figure 4-3. Swept Frequency Response Test Setup

## S E C T I O N V

### REPLACEABLE PARTS

#### 5-1. INTRODUCTION

Table 5-2, Replaceable Parts, identifies the manufacturers of components by five-digit groups taken from the Federal Supply Code for Manufacturers. A list of the applicable code groups and manufacturers is given in Table 5-1.

The Table of Replaceable Parts begins with major assemblies, including PC boards complete with all their parts, followed by miscellaneous parts and components not mounted on PC boards. Then all the components of the individual assemblies (including PC boards) are listed.

To simplify ordering, please note the following:

- A. When ordering a component or an assembly, the BEC Part Number is all that we need. However, part numbers can suffer changes during transmission and it is safer to include also a brief description. Examples:
  - 1) BEC Part #200050: Mica Capacitor, 470 pF, 1%, 500V.
  - 2) BEC Part #102409: Oscillator PC Board Assembly.
- B. The number printed on a PC board is not an assembly number; it is the number for the bare board, alone. To order a complete assembly--the board with all its components installed--specify it by the BEC Part Number given in the Assemblies Section of this table.
- C. Unless otherwise identified, the number on a schematic diagram or on a parts-location diagram is not an assembly number; it is the number for just the diagram itself.

Table 5-1. Applicable Federal Supply Code Numbers for Manufacturers

---

01121	Allen Bradley	27735	F-Dyne Electronics
01295	Texas Instruments	28480	Hewlett-Packard
02260	Amphenol	32293	Intersil, Inc.
02735	RCA	34430	Monsanto
04713	Motorola Semiconductor	51640	Analog Devices
04901	Boonton Electronics	51791	Statek Corp.
06383	Panduit Corp.	54426	Buss Fuses
06776	Robinson Nugent	56289	Sprague Electric
07263	Fairchild Semiconductor	57582	Kahgan
16546	Centralab	71450	CTS Corp.
17856	Siliconix, Inc.	73138	Beckman Instruments - Helipot
19701	Mepco Electra	91506	Augat
20307	Arco - Micronics	98291	Sealectro Co.
27264	Molex, Inc.	S4217	United Chemicon.

Table 5-2. Replaceable Parts

Replaceable Parts List for PWA Main

PL 092155-00A

Reference Symbol	Description	Mfr.	Mfr's Part No.	BEC Part No.
C1	Capacitor EL 2200 $\mu$ F -10%/+50% 35V	57582	KSMM-2200-35	283351-000
C2	Capacitor EL 2200 $\mu$ F -10%/+50% 35V	57582	KSMM-2200-35	283351-000
C3	Capacitor EL 2200 $\mu$ F -10%/+50% 35V	57582	KSMM-2200-35	283351-000
C4	Capacitor EL 100 $\mu$ F 20% 25V	94217	SM-25-VB-100-M	283334-000
C5	Capacitor EL 100 $\mu$ F 20% 25V	94217	SM-25-VB-100-M	283334-000
C6	Capacitor EL 100 $\mu$ F 20% 25V	94217	SM-25-VB-100-M	283334-000
C7	Capacitor EL 10 $\mu$ F 20% 25V	94217	SM-25-VB-10-M	283336-000
C8	Capacitor EL 10 $\mu$ F 20% 25V	94217	SM-25-VB-10-M	283336-000
C9	Capacitor EL 10 $\mu$ F 20% 25V	94217	SM-25-VB-10-M	283336-000
C10	Capacitor EL 10 $\mu$ F 20% 25V	94217	SM-25-VB-10-M	283336-000
C11	Capacitor EL 10 $\mu$ F 20% 25V	94217	SM-25-VB-10-M	283336-000
C12	Capacitor EL 100 $\mu$ F 20% 25V	94217	SM-25-VB-100-M	283336-000
C13	Capacitor PE 0.1 $\mu$ F 10% 200V	56289	192P10492	234005-000
C14	Capacitor PE 0.1 $\mu$ F 10% 200V	56289	192P10492	234005-000
C15	Capacitor EL 100 $\mu$ F 20% 25V	94217	SM-25-VB-100-M	283334-000
C16	Capacitor PP 0.1 $\mu$ F 10% 100V	27735	PP11-.1-100-10	234148-000
C17	Capacitor Cer 150 pF 10% 1 kV	99942	CE-151	224314-000
C18	Capacitor PP 0.1 $\mu$ F 10% 100V	27735	PP11-.1-100-10	234148-000
C19	Capacitor PP 0.1 $\mu$ F 10% 100V	27735	PP11-.1-100-10	234148-000
C20	Capacitor PP 0.1 $\mu$ F 10% 100V	27735	PP11-.1-100-10	234148-000
C21	Capacitor Mica 240 pF 5% 500V	20307	DM15-241J	200506-000
CR1	Diode Bridge KBP-02	20307	KBP-02	532013-000
CR2	Diode Bridge KBP-02	20307	KBP-02	532013-000
CR3	Diode 1N4001	04713	1N4001	530151-000
CR4	Diode 1N4001	04713	1N4001	530151-000
CR5	Diode 1N4001	04713	1N4001	530151-000
CR6	Diode 1N6263 (HSCH-1001)	28480	HSCH-1001	530174-000
CR7	Diode 1N914	01295	1N914	530058-000
CR8	Diode 1N914	01295	1N914	530058-000
CR9	Diode 1N914	01295	1N914	530058-000
CR10	Diode 1N914	01295	1N914	530058-000
CR11	Diode 1N914	01295	1N914	530058-000
J1	Header 6 Circuit	06383	HPSS156-6-C	477346-000
J2	Header 2 Circuit	27264	22-03-2021	477361-000
J4	Header 4 Circuit Polarized	27264	22-04-2041	477373-000
J5	Header 9 Circuit Polarized	06383	HPSS100-9-C	477374-000
J6	Header 2 Circuit	27264	22-03-2021	477361-000
J7	Header 2 Circuit	27264	22-03-2021	477361-000
J3-1	Socket Pin Spring	32575	1-332070-7	479333-000
J3-2	Socket Pin Spring	32575	1-332070-7	479333-000
J3-3	Socket Pin Spring	32575	1-332070-7	479333-000
J3-4	Socket Pin Spring	32575	1-332070-7	479333-000
J3-5	Socket Pin Spring	32575	1-332070-7	479333-000
J3-6	Socket Pin Spring	32575	1-332070-7	479333-000
J3-7	Socket Pin Spring	32575	1-332070-7	479333-000
JA	Header 2 Circuit	27264	22-03-2021	477361-000
JB	Header 2 Circuit	27264	22-03-2021	477361-000
Q1	Transistor PNP 2N3906	04713	2N3906	528076-000
Q2	Transistor NPN 2N5088	04713	2N5088	528047-000
R1	Resistor MF 10.0k ohm 1%	---	RN55D-1002-F	341400-000
R2	Resistor MF 4.99k ohm 1%	---	RN55D-4991-F	341367-000
R3	Resistor MF 2.21k ohm 1%	---	RN55D-2211-F	341333-000
R4	Resistor MF 12.7k ohm 1%	---	RN55D-1272-F	341410-000
R5	Resistor MF 332 ohm 1%	---	RN55D-3320-F	341250-000
R6	Resistor MF 90.9k ohm 1%	---	RN55D-9092-F	341492-000
R7	Resistor MF 90.9k ohm 1%	---	RN55D-9092-F	341492-000
R8	Resistor Comp 12M ohm 5%	01121	CB	343708-000
R9	Resistor MF 165 ohm 1%	---	RN55D-1650-F	341221-000
R10	Resistor Comp 12M ohm 5%	01121	CB	343708-000
R11	Resistor MF 100k ohm 1%	---	RN55D-1003-F	341500-000
R12	Resistor MF 10.0k ohm 1%	---	RN55D-1002-F	341400-000
R13	Resistor MF 1.00k ohm 1%	---	RN55D-1001-F	341300-000
R14	Resistor MF 221 ohm 1%	---	RN55D-2210-F	341233-000
R15	Resistor MF 1.00k ohm 1%	---	RN55D-1001-F	341300-000
R16	Resistor MF 10.0k ohm 1%	---	RN55D-1002-F	341400-000
R17	Resistor MF 100k ohm 1%	---	RN55D-1003-F	341500-000
R18	Resistor MF 8.25k ohm 1%	---	RN55D-8251-F	341388-000
R19	Resistor MF 1.00k ohm 1%	---	RN55D-1001-F	341300-000
R20	Resistor MF 8.25k ohm 1%	---	RN55D-8251-F	341388-000
R21	Resistor MF 1.00k ohm 1%	---	RN55D-1001-F	341300-000
R22	Resistor Comp 1.1M ohm 5%	01121	CB	343604-000
R23	Resistor MF 10.0k ohm 1%	---	RN55D-1002-F	341400-000
R24	Resistor Var 25k ohm 10% 0.5W	73138	72PR25K	311400-000
R25	Resistor Var 25k ohm 10% 0.5W	73138	72PR25K	311400-000
R26	Resistor Var 25k ohm 10% 0.5W	73138	72PR25K	311400-000
R27	Resistor Var 25k ohm 10% 0.5W	73138	72PR25K	311400-000
R28	Resistor Var 25k ohm 10% 0.5W	73138	72PR25K	311400-000
R29	Resistor Var 25k ohm 10% 0.5W	73138	72PR25K	311400-000
R30	Resistor Var 25k ohm 10% 0.5W	73138	72PR25K	311400-000
R31	Resistor Var 25k ohm 10% 0.5W	73138	72PR25K	311400-000

Table 5-2. Replaceable Parts (Continued)

Replaceable Parts List for FWA Main		PL 092155-00A		
Reference Symbol	Description	Mfr.	Mfr's Part No.	BEC Part No.
R32	Resistor MF 53.6k ohm 1%	----	RN55D-5362-F	341470-000
R33	Resistor MF 78.7k ohm 1%	----	RN55D-7872-F	341486-000
R34	Resistor MF 20.0k ohm 1%	----	RN55D-2002-F	341429-000
R35	Resistor MF 53.6k ohm 1%	----	RN55D-5362-F	341470-000
R36	Resistor MF 5.11k ohm 1%	----	RN55D-5111-F	341368-000
R37	Resistor MF 18.7k ohm 1%	----	RN55D-1872-F	341426-000
R38	Resistor MF 1.00k ohm 1%	----	RN55D-1001-F	341300-000
R39	Resistor MF 4.99k ohm 1%	----	RN55D-4991-F	341367-000
R40	Resistor MF 590 ohm 1%	----	RN55D-5900-F	341274-000
R41	Resistor MF 1.33k ohm 1%	----	RN55D-1331-F	341312-000
R42	Resistor MF 150 ohm 1%	----	RN55D-1500-F	341217-000
R43	Resistor MF 267 ohm 1%	----	RN55D-2670-F	341241-000
R44	Resistor MF 10.0k ohm 1%	----	RN55D-1002-F	341400-000
R45	Resistor MF 100k ohm 1%	----	RN55D-1003-F	341500-000
R46	Resistor MF 33.2k ohm 1%	----	RN55D-3322-F	341450-000
R47	Resistor MF 56.2k ohm 1%	----	RN55D-5622-F	341472-000
R48	Resistor Network 3.3k ohm 2% 1.5W	71450	750-101-R3.3K	345030-000
R49	Resistor Network 3.3k ohm 2% 1.5W	71450	750-101-R3.3K	345030-000
R50	Resistor MF 100k ohm 1%	----	RN55D-1003-F	341500-000
R51	Resistor MF 221k ohm 1%	----	RN55D-2213-F	341533-000
R52	Resistor MF 475k ohm 1%	----	RN55D-4753-F	341565-000
R53	Resistor MF 221k ohm 1%	----	RN55D-2213-F	341533-000
R54	Resistor MF 4.75k ohm 1%	----	RN55D-4751-F	341365-000
R55	Resistor MF 4.75k ohm 1%	----	RN55D-4751-F	341365-000
R56	Resistor MF 15.0k ohm 1%	----	RN55D-1502-F	341417-000
R57	Resistor MF 4.99k ohm 1%	----	RN55D-4991-F	341367-000
R58	Resistor MF 511 ohm 1%	----	RN55D-5110-F	341268-000
R59	Resistor MF 20.0k ohm 1%	----	RN55D-2002-F	341429-000
R60	Resistor MF 10.0k ohm 1%	----	RN55D-1002-F	341400-000
R61	Resistor MF 20.0k ohm 1%	----	RN55D-2002-F	341429-000
R62	Resistor MF 20.0k ohm 1%	----	RN55D-2002-F	341429-000
R63	Resistor MF 20.0k ohm 1%	----	RN55D-2002-F	341429-000
R64	Resistor MF 22.1k ohm 1%	----	RN55D-2212-F	341433-000
R65	Resistor MF 221k ohm 1%	----	RN55D-2213-F	341533-000
R66	Resistor MF 10.0k ohm 1%	----	RN55D-1002-F	341400-000
R67	Resistor MF 45.3k ohm 1%	----	RN55D-4532-F	341463-000
R68	Resistor MF 9.09k ohm 1%	----	RN55D-9091-F	341392-000
R69	Resistor MF 499k ohm 1%	----	RN55D-4993-F	341557-000
R70	Resistor Var 10k ohm 10% 0.5W	73138	72FR10K	311328-000
R71	Resistor Var 5K ohm 10% 0.5W	73138	72FR5K	311308-000
R72	Resistor Var 25k ohm 10% 0.5W	73138	72FR25K	311400-000
R73	Resistor Var 1M 20% 0.5W	73138	72FR1M	311418-000
U	IC 79M6U1C Regulator	07263	μ79M6U1C	535097-00A
U1	IC 78M6U1C Regulator	07263	78M6U1C	535042-000
U3	IC μA7805UC Regulator & Hardware	07263	μA7805UC	535011-00A
U4	IC 78L05AUC Regulator	07263	78L05AUC	535044-000
U5	IC 79L05ACP Regulator	04713	MC79L05ACP	535090-000
U6	IC LF356 Op Amp IT/F 535052000	04901	BEC	535062-000
U7	IC IH6208CPE	32293	IH6208CPE	534266-000
U8	IC LF356 Op Amp IT/F 535052000	04901	BEC	535062-000
U9	IC CD4001AE	02735	CD4001AE	534023-000
U10	IC TL074CN Quad Op Amp	01295	TL074CN	535082-000
U11	IC IH6108CPE	32293	IH6108CPE	534265-000
U12	IC CD4066AE	02735	CD4066AE	534078-000
U13	IC CD4081BE	02735	CD4081BE	534142-000
U14	IC CD4013BE (only)	02735	CD4013BE	534205-000
U15	IC CD4012BE	02735	CD4012BE	534325-000
U16	IC CD4013BE (only)	02735	CD4013BE	534205-000
U17	IC CD4012BE	02735	CD4012BE	534325-000
U18	IC 74LS244N Octal Bus Transceiver	01295	SN74LS244N	534247-000
U19	IC CD4011AE	02735	CD4011AE	534022-000
U20	IC CD4040BE	02735	CD4040BE	534275-000
U21	IC CD4556BE	02735	CD4556BE	534324-000
U22	IC Eprom Prog 92E	04901	BEC	534391-000
U23	IC TL431CLP Reference	51640	TL431CLP	535098-000
U24	IC DG211CJ	17856	DG211CJ	534326-000
U25	IC AD7523JN DAC	51640	AD7523JN	535099-000
U26	IC TL074CN Quad Op Amp	01295	TL074CN	535082-000
U27	IC DG211CJ	17856	DG211CJ	534326-000
U28	IC CD4030AE	02735	CD4030AE	534087-000
U29	IC CA3140AE Op Amp	02735	CA3140AE	535050-000
U30	IC CD4013BE (only)	02735	CD4013BE	534205-000
U31	IC CD4071BE	02735	CD4071BE	534141-000
XU6	Socket IC 8 Pin	06776	ICN-083-S3-G	473041-000
XU7	Socket IC 16 Pin	06776	ICN-163-S3-G	473042-000
XU8	Socket IC 8 Pin	06776	ICN-083-S3-G	473041-000
XU9	Socket IC 14 Pin	06776	ICN-143-S3-G	473019-000
XU10	Socket IC 14 Pin	06776	ICN-143-S3-G	473019-000
XU11	Socket IC 16 Pin	06776	ICN-163-S3-G	473042-000
XU12	Socket IC 14 Pin	06776	ICN-143-S3-G	473019-000

Table 5-2. Replaceable Parts (Continued)

Replaceable Parts List for PWA Main Reference

PL 092155-00A

Symbol	Description	Mfr.	Mfr's Part No.	BEC Part No.
XU13	Socket IC 14 Pin	06776	ICN-143-S3-G	473019-000
XU14	Socket IC 14 Pin	06776	ICN-143-S3-G	473019-000
XU15	Socket IC 14 Pin	06776	ICN-143-S3-G	473019-000
XU16	Socket IC 14 Pin	06776	ICN-143-S3-G	473019-000
XU17	Socket IC 14 Pin	06776	ICN-143-S3-G	473019-000
XU18	Socket IC 20 Pin	06776	ICN-203-S3-G	473065-000
XU19	Socket IC 14 Pin	06776	ICN-143-S3-G	473019-000
XU20	Socket IC 16 Pin	06776	ICN-163-S3-G	473042-000
XU21	Socket IC 16 Pin	06776	ICN-163-S3-G	473042-000
XU22	Socket IC 24 Pin	06776	ICN-246-S4-G	473043-000
XU24	Socket IC 16 Pin	06776	ICN-163-S3-G	473042-000
XU25	Socket IC 16 Pin	06776	ICN-163-S3-G	473042-000
XU26	Socket IC 14 Pin	06776	ICN-143-S3-G	473019-000
XU27	Socket IC 16 Pin	06776	ICN-163-S3-G	473042-000
XU28	Socket IC 14 Pin	06776	ICN-143-S3-G	473019-000
XU29	Socket IC 8 Pin	06776	ICN-083-S3-G	473041-000
XU30	Socket IC 14 Pin	06776	ICN-143-S3-G	473019-000
XU31	Socket IC 14 Pin	06776	ICN-143-S3-G	473019-000
Y1	Crystal 96.00 kHz	51791	CX-1H	547036-000

Replaceable Parts List for Chopper Assembly Reference

PL 042161-01G

Symbol	Description	Mfr.	Mfr's Part No.	BEC Part No.
C1	Capacitor PP 0.1 µF 10% 100V	27735	FP11-.1-100-10	234148-000
C2	Capacitor PP 0.1 µF 10% 100V	27735	FP11-.1-100-10	234148-000
IC1	IC CD4016BE (only) IT/F 534354 PED4200-3	04901	BEC	534223-000
P1-1	Terminal	98291	229-1071-23	510038-000
P1-2	Terminal	98291	229-1071-23	510038-000
P1-3	Terminal	98291	229-1071-23	510038-000
P1-4	Terminal	98291	229-1071-23	510038-000
P1-5	Terminal	98291	229-1071-23	510038-000
P1-6	Terminal	98291	229-1071-23	510038-000
P1-7	Terminal	98291	229-1071-23	510038-000
R3	Resistor MF 51.1k ohm 1%	---	RN55D-5112-F	341468-000
R4	Resistor Var 20k ohm 10% 0.5W	73138	72PR20K	311354-000
R5	Resistor Var 20k ohm 10% 0.5W	73138	72PR20K	311354-000
R6	Resistor MF 51.1k ohm 1%	---	RN55D-5112-F	341468-000
XIC1	Socket IC 14 Pin	91506	508-AG7D	473056-000

Replaceable Parts List for Rear Panel Assembly Reference

PL 092153-00A

Symbol	Description	Mfr.	Mfr's Part No.	BEC Part No.
F1	Fuse 0.2 A	54426	MDL 0.2	545508-000
F1	Fuse 0.1 A Slo-Blo	54426	MDL	545519-000
F2	Connector 6 Circuit	06383	CE156F22-6-C	479416-000
T1	Transformer Power	04901	BEC	446071-000
W5	Cable Assembly (DC Analog)	04901	BEC	571177-000

Replaceable Parts List for Sub Panel Assy Reference

PL 092154-00A

Symbol	Description	Mfr.	Mfr's Part No.	BEC Part No.
M1	Meter & Scale M/F 554208, 554215	04901	BEC	554216-000
W6	Cable Assembly (DC Analog)	04901	BEC	571177-000

Replaceable Parts List for Pushbutton Switch Assy Reference

PL 092156-00B

Symbol	Description	Mfr.	Mfr's Part No.	BEC Part No.
S2	Switch Pushbutton Black 2P9T	99942	Series PB-10	465153-00A
W2	Cable Assembly (Power Switch)	04901	BEC	571174-000
W3	Cable Assembly (Range Switch)	04901	BEC	571173-00B

Replaceable Parts List for LED Cable and Bracket Assy Reference

PL 092157-00B

Symbol	Description	Mfr.	Mfr's Part No.	BEC Part No.
CR1	LED MV5025 Red Diffused	34430	MV5025	536000-000

Replaceable Parts List for Zero Pot Assy Reference

PL 092158-00A

Symbol	Description	Mfr.	Mfr's Part No.	BEC Part No.
R1	Resistor Var 5k ohm 10% M/F 311413	04901	BEC	311255-00A
W7P1	Connector 4 Circuit KK-100	27264	22-01-2047	479429-000

S E C T I O N VI

SCHEMATIC DIAGRAMS

TABLE OF CONTENTS

Figure	Page
6-1. Main-Frame Assembly Schematic Diagram .....	6-3/6-4
6-2. Main P-C Board (Power Supply Section), Schematic Diagram .....	6-5/6-6
6-3. Main P-C Board Schematic and Parts Location Diagram .....	6-7/6-8
6-4. Main P-C Board Schematic Diagram .....	6-9/6-10
6-5. Chopper P-C Board Schematic and Parts Location Diagram .....	6-11/6-12





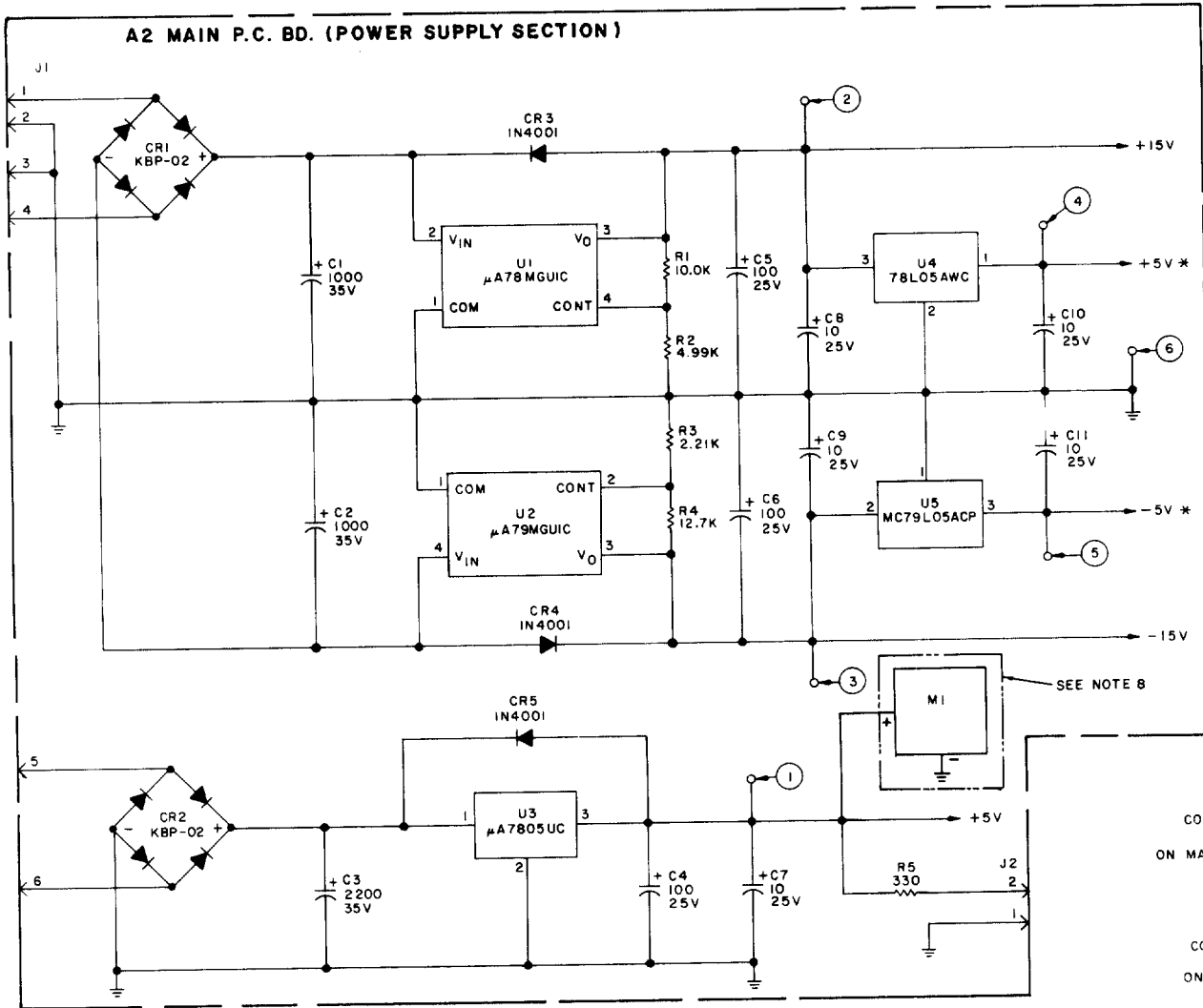

**NOTES:**

1. CAPACITANCE VALUES IN  $\mu$ F UNLESS OTHERWISE SPECIFIED.
2. RESISTANCE VALUES IN OHMS.
3. ⊗ SELECTED VALUES.
4.  $\nabla$  ANALOG GROUND.
5.  $\perp$  DIGITAL GROUND.
5. JUMPERS "A" & "B" DETERMINED BY SENSOR CHARACTERISTICS.
6. LAST NUMBERS USED:  
U31, R73, C21, CR11
7. TEST CONDITIONS:  
1 VRMS AT INPUT TO SENSOR.
8. USED ON 92E-S5 ONLY.

SCHEMATIC  
MAIN P.C. BOARD  
D831300 D, SHT. 2a of 2

Figure 6-2. Main P-C Board  
(Power Supply Section)  
Schematic Diagram

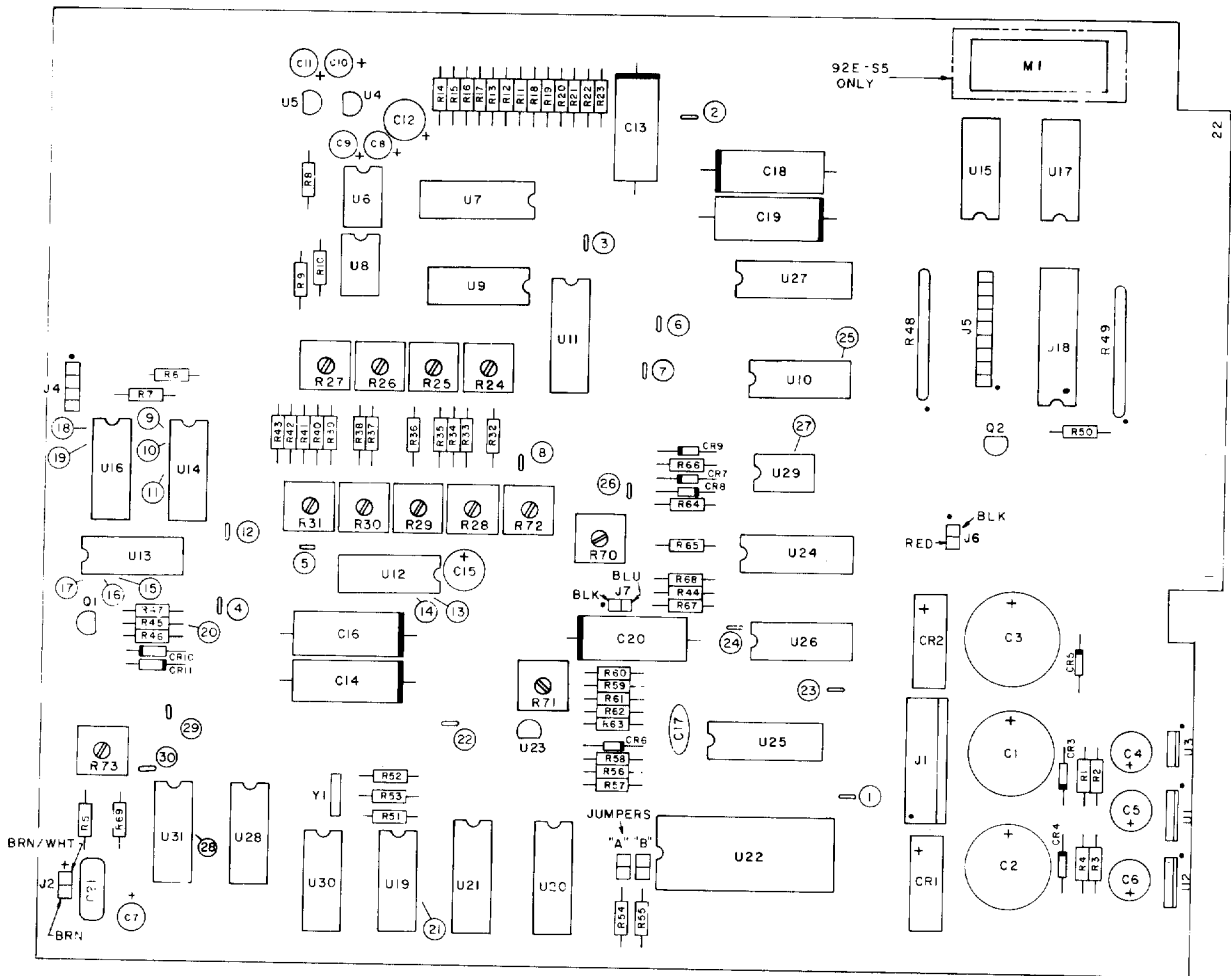

831301E

Figure 6-3. Main P-C Board  
Parts Location Diagram

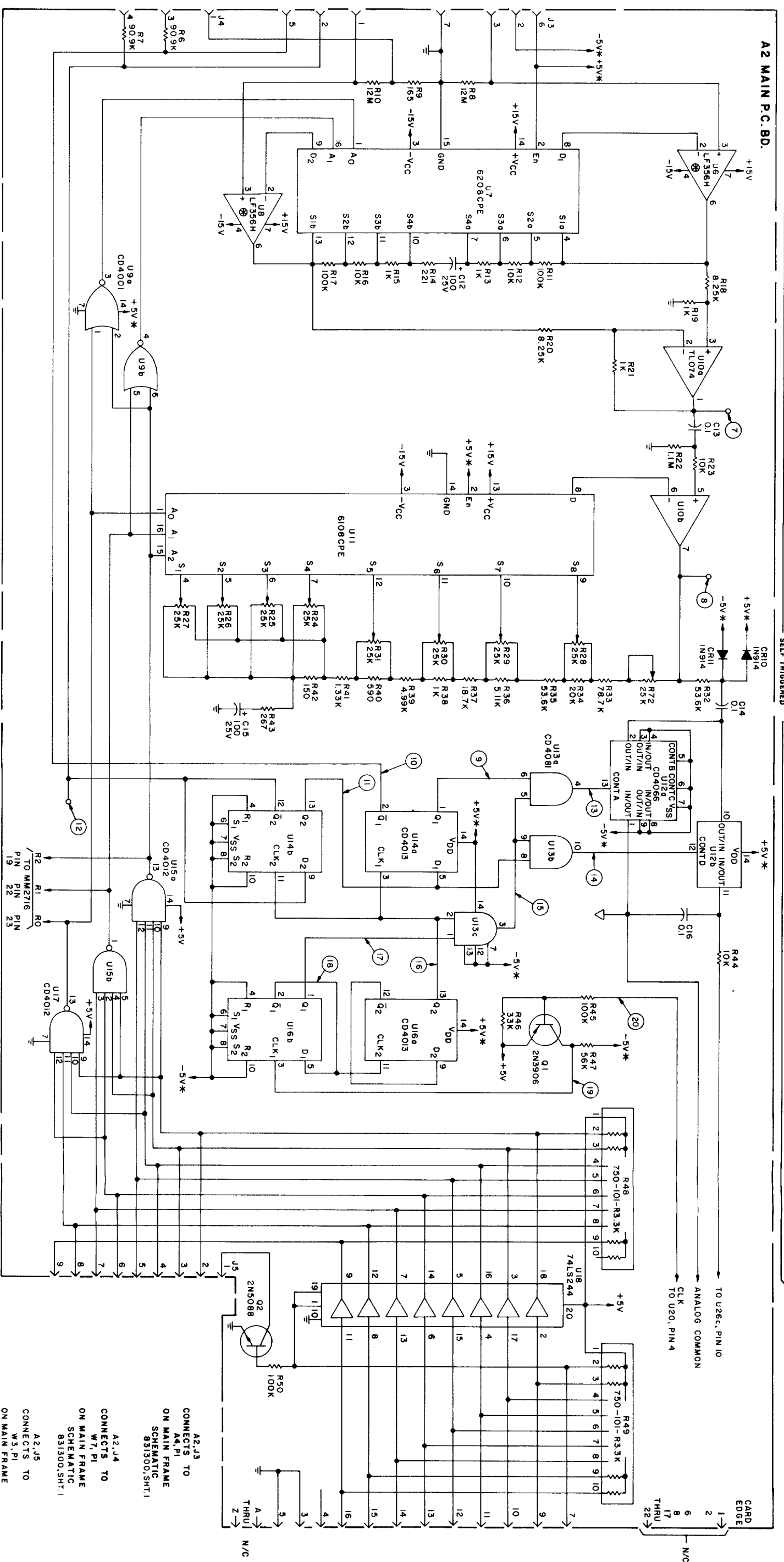
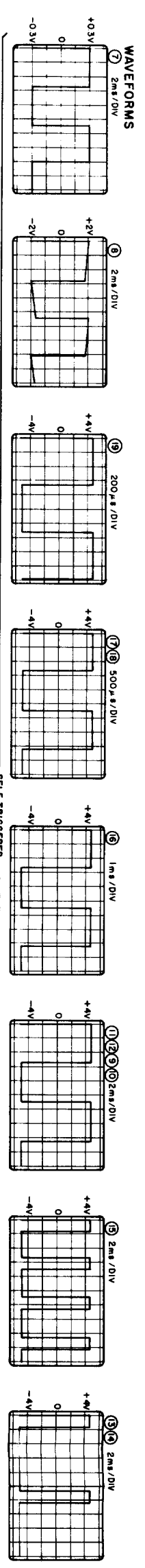

SCHEMATIC  
MAIN P.C. BOARD  
E831300 E SHT.2b of 2

- A2,J3 CONNECTS TO A4,P1 ON MAIN FRAME SCHEMATIC 831300.SHT.1
- A2,J4 CONNECTS TO W7,P1 ON MAIN FRAME SCHEMATIC 831300.SHT.1
- A2,J5 CONNECTS TO W3,P1 ON MAIN FRAME SCHEMATIC 831300.SHT.1

Figure 6-4. Main P-C Board Schematic Diagram Sheet 1  
6-7/6-8

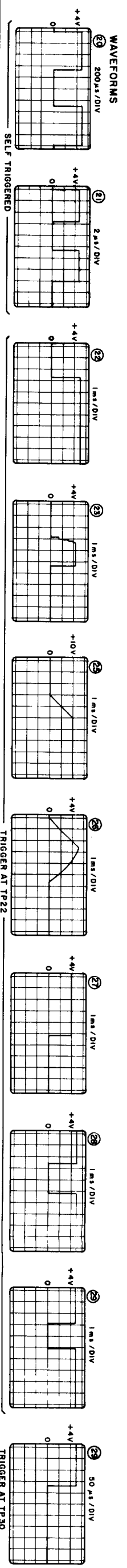

A2 MAIN P.C. BD.

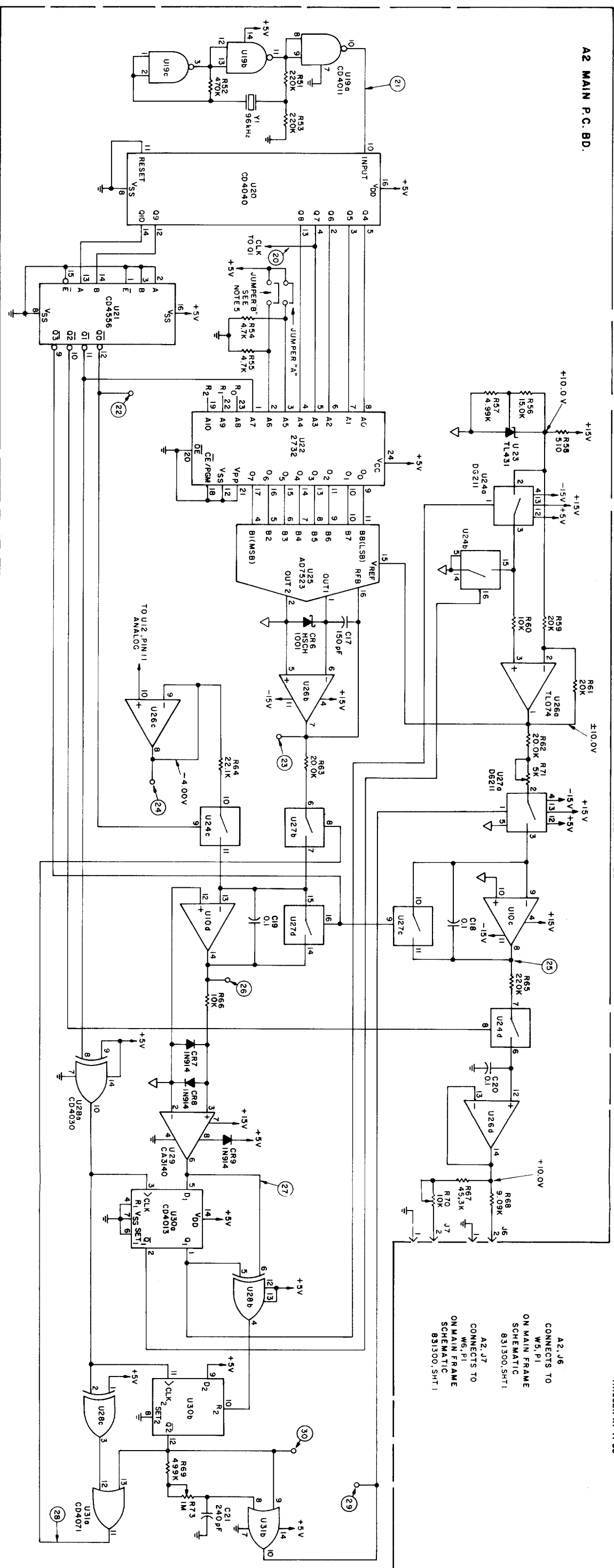

SCHEMATIC  
MAIN P.C. BOARD  
E831300E SHT. 2c of 2

Figure 6-5. Main P-C Board  
Schematic Diagram  
Sheet 2

A4 CHOPPER P.C. BD.

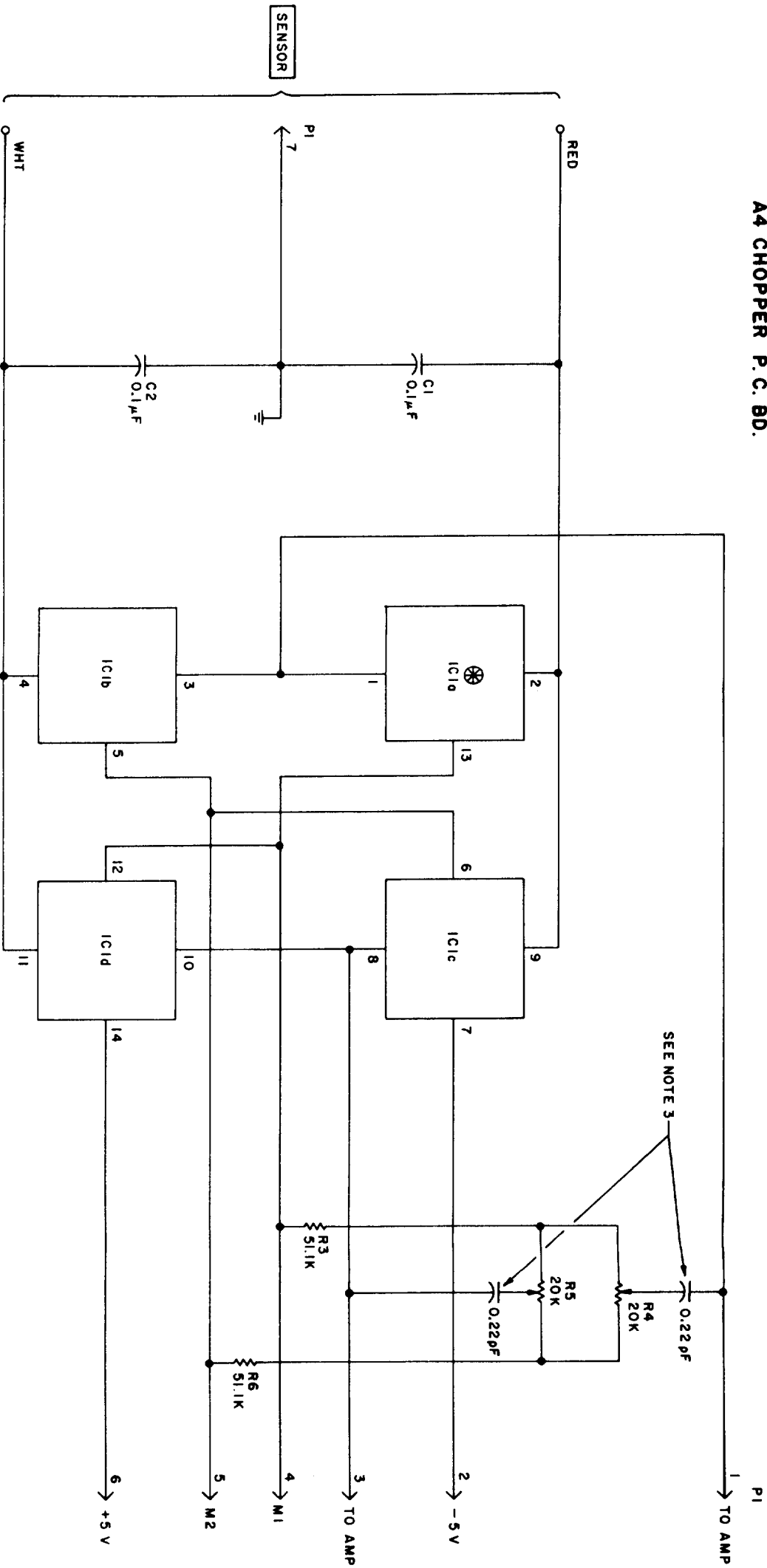

Parts-Location Diagram (B831045D)

- NOTES:
1. RESISTANCE VALUES IN OHMS.
  2.  $\otimes$  SELECTED VALUE.
  3. CAPACITANCE IS PART OF P.C. BD. CIRCUITRY.
  4.  $\square$  EXTERNAL MARKING.
  5. LAST NUMBERS USED:  
R6
  6. NUMBERS NOT USED:  
R1, R2

P1  
CONNECTS TO  
A6 J1  
ON FRAME SCHEMATIC  
831271  
SHT. 1 OF 7  
AND  
A6 J1  
ON OPTION FRAME  
SCHEMATIC  
831099  
AND  
A2 J2  
ON FRAME SCHEMATIC  
831170  
SHT. 1 OF 3

Figure 6-6. Chopper P-C Board  
Schematic and Parts  
Location Diagram

# WARRANTY

Boonton Electronics Corporation warrants its products to the original purchaser to be free from defects in material and workmanship and to operate within applicable specifications for a period of one year from date of shipment, provided they are used under normal operating conditions. This warranty does not apply to active devices that have given normal service, to sealed assemblies which have been opened or to any item which has been repaired or altered without our authorization.

We will repair, or at our option, replace any of our products which are found to be defective under the terms of this warranty.

There will be no charge for parts, labor, or forward and return normal ground transportation during the first three months of this warranty.\*

There will be no charge for parts, labor, or return normal ground transportation during the fourth through twelfth month of this warranty.\*

Except for such repair or replacement, we will not be liable for any incidental damages or for any consequential damages, as those terms are defined in Section 2-715 of the Uniform Commercial Code, in connection with products covered by this warranty.

\*For overseas shipments, there will be no charge for Air Freight during these specified time periods.

## **BOONTON**

BOONTON ELECTRONICS CORPORATION ■ 791 ROUTE 10 ■ RANDOLPH, NEW JERSEY 07869  
TELEPHONE: (201) 584-1077 ■ TLX: 710-986-8215 BOONTRONICS