

OPERATING AND SERVICE MANUAL

POWER AMPLIFIER

230B

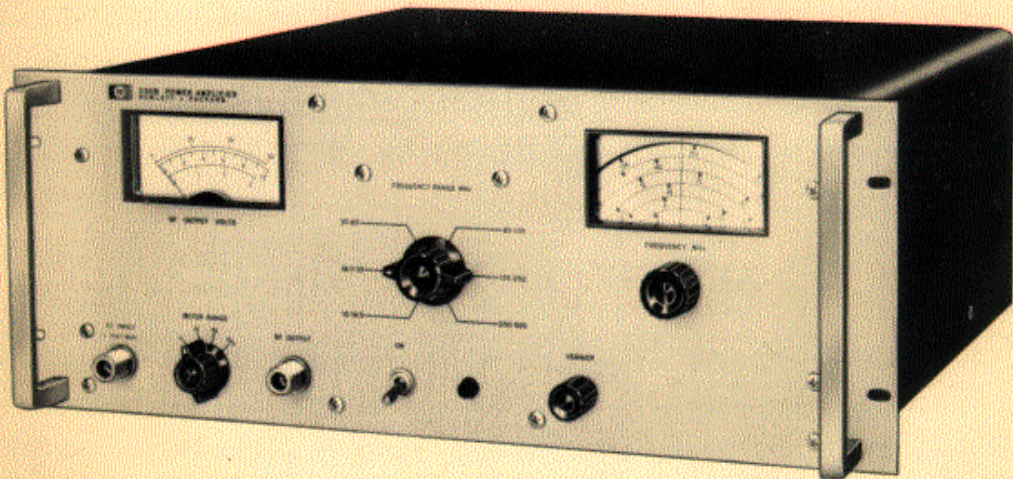

HEWLETT  PACKARD

HP230B



**POWER AMPLIFIER
MODEL 230B**

OPERATING AND SERVICE MANUAL

FOR SERIALS 935-02700 - up*

*For Serials Above 935-02700
A change page may
be included.

Green Pond Road, Rockaway, New Jersey 07866

HP Part No. 00230-90001

90039

Printed: August, 1969

TABLE OF CONTENTS

Section	Page No.	Section	Page No.		
I	GENERAL INFORMATION	1-1	V	MAINTENANCE	5-1
	1-1 Description	1-1	5-1	Introduction	5-1
	1-3 Instrument Identification	1-1	5-3	Test Equipment Required	5-1
II	INSTALLATION	2-1	5-5	Performance Checks	5-2
	2-1 Initial Inspection	2-1	5-8	Frequency Dial Accuracy	5-2
	2-2 Mechanical Check	2-1	5-10	Bandwidth Check	5-2
	2-4 Performance Check	2-1	5-12	Gain Check	5-4
	2-6 Claim for Damage	2-1	5-14	Voltmeter Accuracy	5-4
	2-8 Preparation for Use	2-1	5-16	Adjustment Procedures	5-5
	2-9 Power Requirements	2-1	5-18	Preparation for Adjustment	5-5
	2-11 115/230 Volt Operation	2-1	5-20	Meter Mechanical Adjust- ment	5-5
	2-14 Power Cable	2-1	5-22	Power Supplies	5-5
	2-17 Cooling	2-1	5-24	RF Adjustments	5-5
	2-19 Rack Mounting	2-1	5-27	Oscilloscope Control Settings	5-6
	2-21 Repackaging for Shipment	2-2	5-29	250-500MHz Adjustment	5-6
III	OPERATION	3-1	5-31	125-250MHz Adjustment	5-6
	3-1 Introduction	3-1	5-33	65-125MHz Adjustment	5-6
	3-3 Controls and Indicators	3-1	5-35	35-65MHz Adjustments	5-7
	3-5 Operating Instructions	3-1	5-37	18.5-35MHz Adjustment	5-7
	3-7 Turn-On Procedure	3-1	5-39	10-18.5MHz Adjustment	5-7
	3-9 Operating Procedures	3-1	5-41	Voltmeter Full-Scale Adjust	5-7
	3-11 Frequency Response	3-2	5-43	Component Replacement Procedures	5-7
	3-15 RF Voltmeter	3-2	5-45	Tube Replacement	5-7
	3-17 VSWR	3-2	5-47	Detector Disassembly	5-8
	3-19 Noise Figure	3-3	5-49	Capacitor Piston Replace- ment	5-8
	3-21 Applications	3-3	5-51	Piston Mechanical Align- ment	5-8
	3-23 AGC Characteristics	3-3	5-53	Capacitor Glass Tube Replacement	5-9
	3-25 Skirt Selectivity	3-3	5-55	Blower Maintenance	5-9
	3-27 Adjacent Channel Desen- sitization Test	3-3	5-57	Lubrication	5-9
	3-30 High Level Driver	3-3	5-59	Selected Components	5-9
	3-32 Antenna Testing	3-3	5-64	Troubleshooting	5-10
	3-34 Attenuation Measurements	3-3			
	3-37 Frequency Multiplying	3-3			
IV	THEORY OF OPERATION	4-1	VI	REPLACEABLE PARTS	6-1
	4-1 Introduction	4-1	6-1	Introduction	6-1
	4-3 Overall Description	4-1	6-4	Ordering Information	6-1
	4-6 Detailed Description	4-1			
	4-7 RF Amplifiers	4-1	VII	CIRCUIT DIAGRAMS	7-1
	4-13 Meter Circuit	4-2			
	4-15 Power Supply	4-2			

LIST OF ILLUSTRATIONS

Figure		Page No.
3-1	230B Operating Controls	3-1
3-2	230B Bandwidth vs Frequency	3-2
3-3	Connections For Desensitization	3-3
4-1	230B Block Diagram	4-1
5-1	230B Frequency Accuracy Test Setup	5-2
5-2	230B Bandwidth Test Setup	5-3
5-3	230B Bandwidth Check Waveforms	5-3
5-4	230B Gain Check Setup	5-4
5-5	230B Voltmeter Accuracy Setup	5-5
5-6	230B Adjustments	5-5
5-7	2C39A Removal	5-8
5-8	Detector Removal	5-8
5-9	Piston Diameters	5-9

LIST OF TABLES

Table		Page No.
1-1	Specifications	1-1
5-1	Test Equipment Required	5-1
5-2	Short Piston Color Codes	5-10
6-1	Reference Designators	6-1
6-2	Description Abbreviations	6-1
6-3	Code List of Manufacturers	6-2
6-4	Replaceable Parts	6-5

SECTION I GENERAL INFORMATION

1-1 DESCRIPTION

1-2 The Model 230B Signal Generator Power Amplifier, shown on the cover, is manufactured by Hewlett-Packard. The amplifier offers a convenient way of obtaining high level RF from the output of conventional signal generators. When used in 50 ohm systems, it is capable of producing up to 4.5 Watts output in the 10MHz to 500MHz frequency range and will reproduce AM, FM, Pulse or CW modulation within its bandwidth capabilities. The 230B employs three grounded grid amplifiers to produce linear, class AB, operation with a typical noise figure of 6 to 9dB. The entire 10 to 500MHz is covered in six ranges and an RF voltmeter is provided which indicates the voltage at the front panel RF OUTPUT connector. Complete specifications are provided in Table 1-1.

1-3 INSTRUMENT IDENTIFICATION

1-4 Each Model 230B carries a two-section, eight-digit serial number (e. g. , 000-00000) which is stamped on a plate fastened to the rear panel. The five-digit number is an identification unique to each instrument, and the three-digit number is a serial prefix used to document instrument revisions.

1-5 When the SERIALS PREFIXED number on the title page of this manual is the same as the first three digits of the instrument serial number, the manual applies directly to the instrument. A change sheet will be included with the manual for newer instruments having a higher serial prefix than shown on the title page. If a change sheet is missing, it can be supplied by any Hewlett-Packard Sales Office listed at the back of this manual.

Table 1-1. Specifications

<p>FREQUENCY RANGE: Range 1: 10 to 18.5MHz Range 2: 18.5 to 35MHz Range 3: 35 to 65MHz Range 4: 65 to 125MHz Range 5: 125 to 250MHz Range 6: 250 to 500MHz</p> <p>RF GAIN 30dB (10 to 125MHz) 27dB (125 to 250MHz) 24dB (250 to 500MHz) (with 10 Volts output into 50 ohms)</p> <p>RF BANDWIDTH >700kHz (10 to 150MHz) >1.4MHz (150 to 500MHz) (with 10 Volts output into 50 ohms)</p> <p>RF OUTPUT Level: Up to 15 Volts across external 50 ohm load (4.5 Watts).</p> <p>LEVEL MONITOR Ranges: 3, 10, 30 Volts full-scale Accuracy: 10% from 10 to 500MHz</p>	<p>FREQUENCY CALIBRATION: Calibration: Increments of approximately 10% accurate to $\pm 10\%$.</p> <p>AM CHARACTERISTICS AM Range: Reproduces 0 to 100% modulation of driving source. AM Distortion: <10% added to distortion of driving source, up to 5 Volts maximum carrier output for up to 100% AM.</p> <p>FM CHARACTERISTICS FM Range: Reproduces modulation of driving source, except as limited by RF bandwidth. Incidental AM: <10% added to modulation of driving signal generator at 150kHz deviation. FM Distortion: Negligible distortion added to distortion of driving signal generator for <150kHz deviations and modulation frequencies.</p> <p>POWER REQUIREMENTS 105 to 125 Volts or 210 to 250 Volts, 50 or 60Hz, 150 Watts.</p> <p>CONNECTORS: Type N Female.</p>
---	--

SECTION II INSTALLATION

2-1 INITIAL INSPECTION

2-2 MECHANICAL CHECK

2-3 If damage to the shipping carton is evident, ask that the carrier's agent be present when the instrument is unpacked. Inspect the instrument for scratches, dents, broken knobs and switches, and any other mechanical damage. Also check the cushioning material for signs of severe stress as an indication of rough handling in transit.

2-4 PERFORMANCE CHECK

2-5 The electrical performance of the 230B should be verified as soon as possible after receipt. A performance check that is suitable for initial inspection is contained in Section V.

2-6 CLAIM FOR DAMAGE

2-7 If upon receipt, the 230B is damaged or fails to meet performance specifications, notify the carrier and the nearest Hewlett-Packard Sales and Service Office immediately (a list of offices is provided at the back of this manual). Retain the shipping carton and padding material for the carrier's inspection.

2-8 PREPARATION FOR USE

2-9 POWER REQUIREMENTS

2-10 The 230B requires a power source of 105 to 125V or 210 to 250V, 50 or 60Hz, 150 Watts.

2-11 115/230 VOLT OPERATION

2-12 A two position slide switch, located on the rear panel, permits operation from either a 115 or 230 Volt source. Before connecting the 230B to the power source, check that the number visible on the slide switch matches the line voltage. If required, slide the switch to the other position using a thin-bladed screwdriver.

2-13 When the instrument leaves the factory, the proper fuse is installed for 115 Volt operation. An

envelope containing a fuse for 230 Volt operation is attached to the front handle. Be sure that the correct fuse is installed if the position of the slide switch is changed. Markings on the chassis next to the slide switch indicate the correct fuse rating for operation from either source.

2-14 POWER CABLE

2-15 To protect operating personnel, the National Electrical Manufacturers' Association (NEMA) recommends that instrument panels and cabinets be grounded. The 230B is equipped with a detachable, three-conductor power cable which, when plugged into an appropriate receptacle, grounds the panel and cabinet of the instrument. The offset pin on the power cable three-prong connector is the ground pin. The power connector is in accordance with CEE 22, Standard VI.

2-16 To preserve the protective feature when operating the instrument from a two-contact outlet, use a three-prong adapter (Ⓢ Stock No. 1251-0048) and connect the green pigtail on the adapter to ground.

2-17 COOLING

2-18 The 230B uses a forced-air cooling system. The air intake and filter are located at the rear of the instrument. For adequate ventilation, allow at least 3 inches clearance around the filter and cabinet ventilation holes.

CAUTION

Damage to 230B components may result from a dirty air filter. Check filter regularly and clean when necessary.

2-19 RACK MOUNTING

2-20 The 230B is designed for either bench or rack mounting operation. To install it in a rack

type installation, remove the four rubber feet from the bottom plate.

2-21 REPACKAGING FOR SHIPMENT

2-22 The original shipping carton and packing material should be used for repackaging. A Hewlett-Packard Sales and Service Office will provide information and recommendations on materials to be used if the original packaging materials are not available or reusable.

NOTE

If the instrument is to be shipped to a Hewlett-Packard Sales and Service Office, attach a tag showing owner, model number, complete serial number, and repairs required. Mark the shipping container FRAGILE to ensure careful handling. In any correspondence, refer to the instrument by model number and full serial number.

SECTION III OPERATION

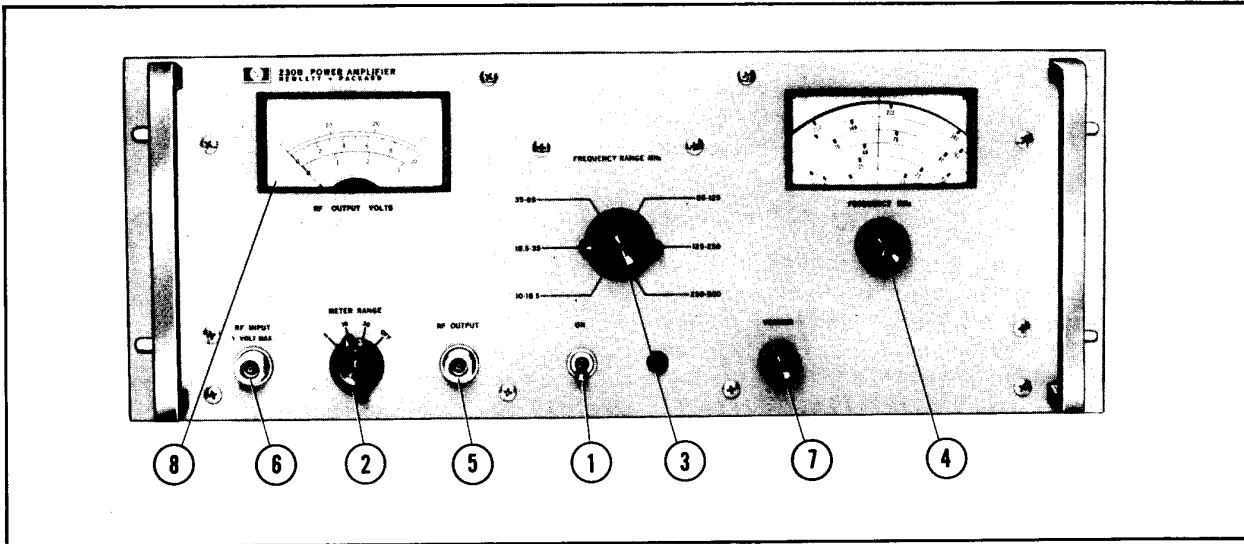

Figure 3-1. 230B Operating Controls

3-1 INTRODUCTION

3-2 The 230B Power Amplifier is designed to increase the output power of a conventional signal generator and becomes a high level signal source in the VHF range from 10MHz to 500MHz. With a typical noise figure of 6 to 9dB, the instrument provides up to 30dB of gain and a maximum power output of 4.5 Watts. It can be driven with any conventional signal source, and will reproduce AM, FM, and Pulse modulation within the 230B bandwidth limitations. The 230B may be used for both high and low level applications.

3-3 CONTROLS AND INDICATORS

3-4 Figure 3-1 identifies the function of the front and rear panel controls, indicators, and connectors.

3-5 OPERATING INSTRUCTIONS

3-6 The following paragraphs describe the 230B turn-on and operating procedures. All numbers following control and connector names refer to callouts in Figure 3-1.

3-7 TURN-ON PROCEDURE

3-8 To turn on the 230B, proceed as follows:

- a. Check that 115/230 Volt slide switch is set for the nominal line voltage. The switch position can be changed by using a thin-bladed screwdriver.
- b. Check that proper line fuse is installed in the fuseholder. The correct fuse rating is marked on the chassis next to the 115/230 Volt slide switch.
- c. Connect one end of power cable to the line input connector and the other end to the appropriate line voltage source.
- d. Set power switch (1) to ON position, and allow 15 minutes warm-up before proceeding.

3-9 OPERATING PROCEDURES

3-10 To operate the 230B as a power amplifier, proceed as follows:

CAUTION

To avoid output circuit damage, especially at the high end of the first two ranges (18.5MHz and 35MHz), DO NOT operate unit with more than one Volt input or an unterminated output.

- a. Set voltmeter RANGE switch (2) to 30.
- b. Set Frequency Range switch (3) to desired range.
- c. Adjust FREQUENCY MHz (4) to desired range.
- d. Connect RF OUTPUT connector (5) to equipment under test.
- e. Connect external signal to RF INPUT connector (6).
- f. Using the VERNIER tuning control (7), tune for a maximum indication on the voltmeter (8). The output voltage is then read directly from the meter.

3-11 FREQUENCY RESPONSE

3-12 Figure 3-2 illustrates 230B typical bandwidth at the response curve 3dB points. The 230B reproduction fidelity for AM signals is dependant upon two factors; (1) the 230B bandwidth at the frequency to which it is tuned and (2) the modulating frequency of the input signal. The minimum 230B bandwidth at the response curve 3dB points is approximately 700kHz.

3-13 The reproduction fidelity of FM signals can be determined by the following relationship:

$$BW \text{ required} = 2 (\text{MOD FREQ}) (M + 1)$$

$$\text{When } M = \frac{\text{Deviation}}{\text{Modulating Freq}}$$

Where: BW = Bandwidth
M = Modulation Index

Using Figure 3-2, the required bandwidth may be compared with the 230B typical bandwidth at the frequency desired.

3-14 If the 230B does not have sufficient bandwidth at the desired frequency, the first and second RF amplifiers may be stagger tuned to provide more bandwidth. However, by obtaining bandwidth in this manner, there will be a sacrifice of gain.

3-15 RF VOLTMETER

3-16 The meter detector is physically connected to the output connector. When operating at the higher frequencies, the length of the connecting lead becomes important in that if there is a mismatch between the 230B output impedance and the load impedance, there could be sufficient VSWR to cause the meter to read something other than the actual voltage at the RF OUTPUT connector.

3-17 VSWR

3-18 The Model 230B was designed for use in 50 ohm systems. A wide-band, tuned amplifier, such as the 230B, however, cannot maintain a constant output impedance without a complex method of controlling both output coupling coefficient and tank circuit reactance, or allowing for an insertion loss of a broad-band matching pad. Where the application requires it, the 230B input and output impedances may be matched to the source or load through matching networks, pads, or stub tuners, depending upon power gain requirements and operating frequency.

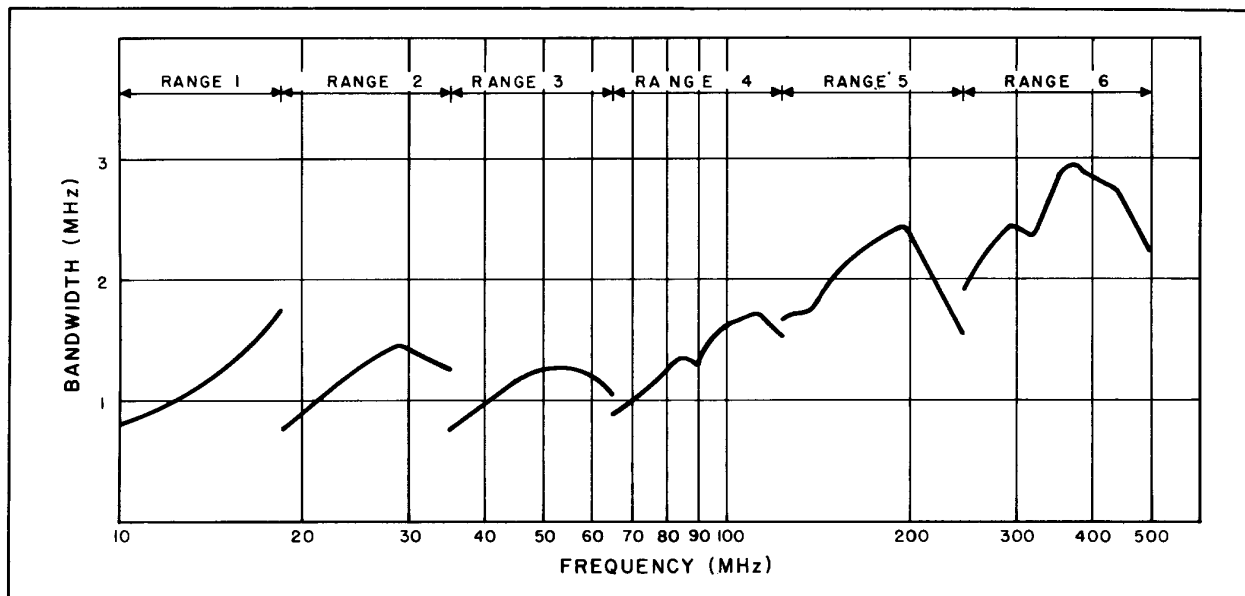

Figure 3-2. 230B Bandwidth vs Frequency

3-19 NOISE FIGURE

3-20 The equivalent noise figure for the 230B is kept very low; typically 6 to 9dB over the entire frequency range.

3-21 APPLICATIONS

3-22 The following paragraphs list some typical 230B applications.

3-23 AGC CHARACTERISTICS

3-24 AGC (automatic gain control) characteristics are measured or determined by measuring the relationship between RF input voltage and the dc voltage bias developed by the AGC detector. It is often desirable to determine the RF level which will override the AGC and cause blocking and/or distortion. This level is often much higher than 500,000 microvolts in well-designed systems.

3-25 SKIRT SELECTIVITY

3-26 Skirt selectivity testing of a communications system requires that the performance of the frequency selective circuits be determined at a frequency considerably removed from the desired frequency, or on the "skirts" of the resonance curve, where attenuation is at a very high value. Typical values are 2 to 5 Volts for attenuation figures of 80 to 120dB. In this test, one must be cautious of the possibility of overload occurring before the desired point on the skirt is reached. In AM systems, an increase in distortion indicates that overloading has taken place and limits the extent of the "skirt" measurement.

3-27 ADJACENT CHANNEL DESENSITIZATION TEST

3-28 Most communication centers transmit on many channels simultaneously. Usually, a given receiver will be in contact with signals of less than 100 microvolts in strength, while one or more transmitters in the same room are operating at a frequency only a few channels from the receiver frequency. The receiver must not, therefore, be affected by strong signals in adjacent channels. It is for this reason that desensitization characteristics are specified by communication system designers, and the desensitization tests are made.

3-29 Desensitization tests are made by connecting the equipment as shown in Figure 3-3. Signal generator #1 is set to give a convenient metered detector level (sometimes specified for a given system). This is the "desired signal" on channel. Using signal generator #2 in conjunction with the 230B Power Amplifier, the adjacent channel level is raised until the detector level is reduced by a specific amount (usually 3dB). The reading on the

230B voltmeter is twice the voltage required for "desensitization".

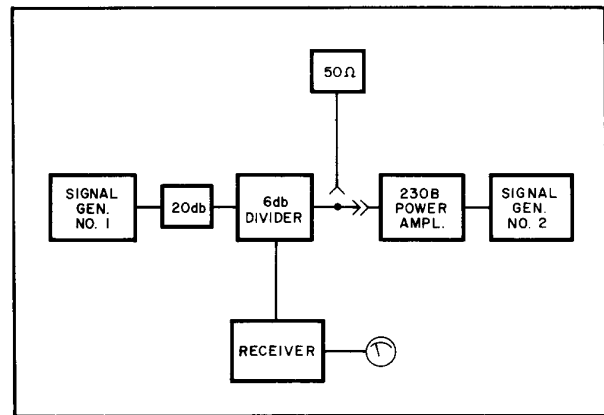

Figure 3-3. Connections For Desensitization

3-30 HIGH LEVEL DRIVER

3-31 As a high level driver, the 230B can be used to power bridges and slotted lines to improve the resolution and accuracy of these measurements. Computers that require high-level signal sources for synchronizing purposes, at moderately high frequencies, may also be driven by the 230B Power Amplifier.

3-32 ANTENNA TESTING

3-33 The 230B is capable of supplying moderate power for antenna measurements, while, at the same time, providing relatively small leakage from the Power Amplifier itself.

3-34 ATTENUATION MEASUREMENTS

3-35 Using the 230B Power Amplifier and an RF millivolt meter, attenuation measurements can be made in the order of 80dB. The 230B provides an additional 24 to 30dB of gain or signal level (assuming the circuit being measured will permit the high voltage) to add to the existing measuring system in the field of attenuation measurements, filters, long transmission lines, etc., can be tested in this manner.

3-36 Certain of these applications are susceptible to the absolute values of the source or load impedance. Where these impedances are critical, matching pads, attenuators, stub tuners or tunable networks may be employed to accomplish the necessary proper match for the application.

3-37 FREQUENCY MULTIPLYING

3-38 A number of approaches to this application

are possible. First, it is possible to amplify the harmonics present in the input signal. The output under these conditions is in the order of 0.2 to 0.5 Volts, with 0.2 Volts of fundamental input. Another approach is to use a semiconductor harmonic generator to augment the harmonics present in the input signal. This technique yields several Volts output, depending upon the input levels available. If sufficient input is available, the 230B input stage may be overdriven and the attendant distortion will pro-

duce higher harmonic levels. Approximately 1 to 2 Volts may be expected for inputs of the order of 1 Volt. A crystal frequency synthesizer output may be multiplied as many as ten times, extending the usefulness of these units to the UHF range. Further information is contained in the Hewlett-Packard Application Note 920, "Harmonic Generation using Step Recovery Diodes and Step Recovery Diode Modules" available through your local HP office.

SECTION IV THEORY OF OPERATION

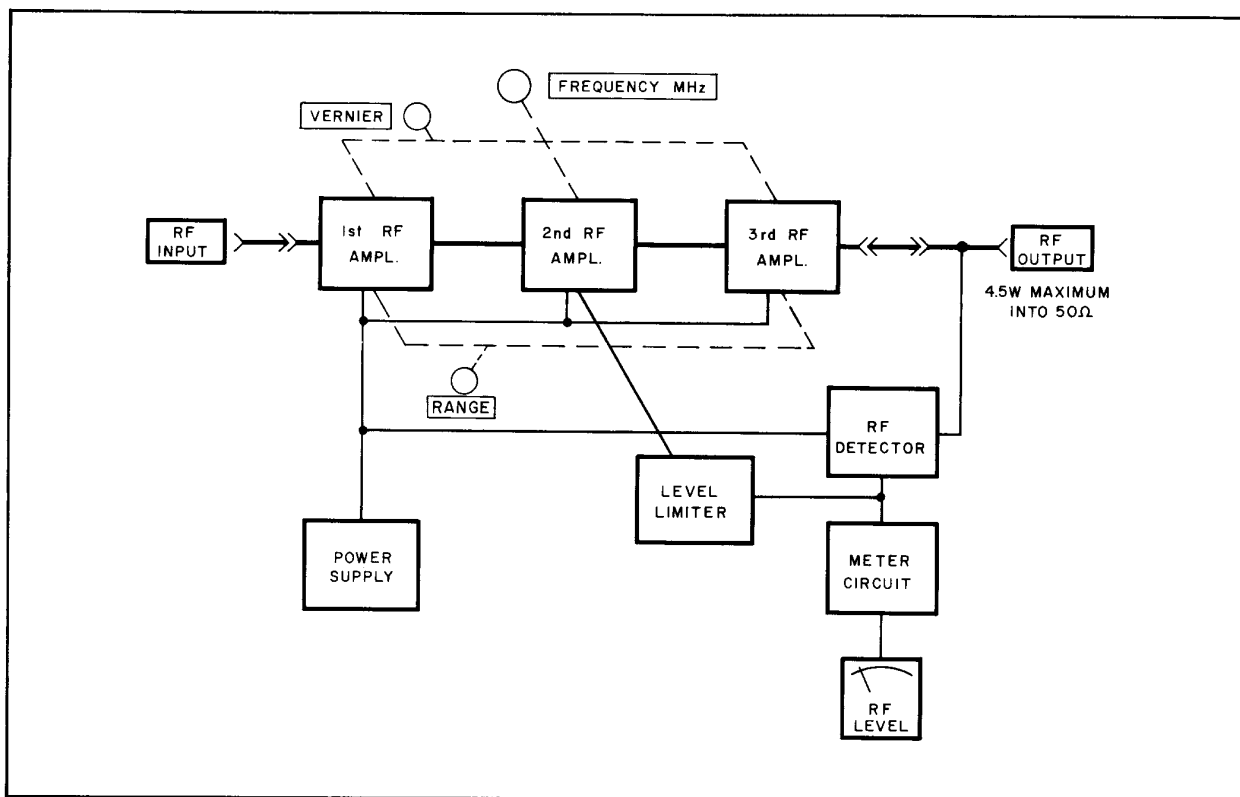

Figure 4-1. 230B Block Diagram

4-1 INTRODUCTION

4-2 The Model 230B Power Amplifier is capable of increasing low level signals up to 30dB. It employs three grounded-grid amplifiers, tuneable from 10MHz to 500MHz, in three ranges, and an RF voltmeter to monitor the output.

4-3 OVERALL DESCRIPTION

4-4 Figure 4-1 is a block diagram of the 230B. The input signal is amplified by the three grounded-grid amplifiers, the first being operated class A and the second and output amplifiers operated class AB.

4-5 At the output, a portion of the RF output is detected and used to drive the RF voltmeter. The voltmeter is calibrated to read rms Volts.

4-6 DETAILED DESCRIPTION

4-7 RF AMPLIFIERS

4-8 The RF amplifiers in the 230B use conventional grounded-grid circuitry. Special 2C39A tubes with reduced size radiators are used in all three stages to increase coupling efficiency at 500MHz. Since all three stages are alike only the second stage will be discussed.

4-9 Transistors Q1 and Q2 and associated components form an output level limiter. During normal operation, VR6 is non-conducting. Q1-Q2 are held in saturation by the positive current source through R11. The cathode current of V2 flows through CR7 and Q2 (normally saturated) and provides a fixed bias of approximately +1.4V at the cathode of A2V2.

4-10 When the RF output voltage exceeds approximately 30Vrms (43V pk) VR6 begins to conduct. This reduces the current flow into the base of Q1 thus causing Q2 to go out of saturation. Since the cathode current of V2 is flowing through Q2, its Vce increases. This in turn increases the + voltage at the cathode of V2 which reduces the output to a point not exceeding 30Vrms. This action reduces the possibility of any internal damage that might occur if the output exceeded 30Vrms.

4-11 The tuned plate circuit consists of C11 and C12 in series across the plate circuit inductance. As the 230B is tuned from the low end of a range to the high end, a point is reached (approx. 320 MHz on range 6) at which C12 becomes ineffective as part of the tuning process. At this point the circuit changes from series-parallel tuned to series tuned. This is accomplished by making the piston of C12 (C4 and C18) physically shorter than C11 (C4 and C18). The results of this tuning method are greater tuning ratio, and less compression of frequencies at the high end of the dial. The complete frequency range is covered by inserting different value plate circuit inductors, by means of a turret switching assembly.

4-12 The plate circuit inductors for the first and output stages are identical while those of the second stage are wound in the reverse direction from the other two stages. This reduces the possibility of regeneration occurring.

4-13 METER CIRCUIT

4-14 The meter circuit provides an indication of

the rms output. The RF detector provides the input to the circuit. The METER RANGE switch selects the desired range by providing the proper voltage dividing resistor in series with the meter. R13 allows calibration of the meter sensitivity.

4-15 POWER SUPPLY

4-16 The 230B power supply consists of power transformer T1, bridge rectifier CR1-CR4, series regulator V1, error amplifier V2 and reference tube V3.

4-17 The cathode of V1 supplies a regulated +320 Volts to the three RF amplifiers. Series regulator V1 serves as an adjustable impedance in series with the output, controlled by error amplifier V2. Error amplifier V2 samples a portion of the regulated output obtained from a voltage divider consisting of R4, R5 and R18. R18 is adjusted for +320 Volts at the cathode of V1.

4-18 Regulation is accomplished by the application of the sampled voltage to the grid of V2. V2 amplifies any changes in the output and applies it in the proper phase and amplitude to the grid of V2. This causes V2 to conduct more or less in accordance with the error signal applied to it, thus obtaining the proper well-regulated output at the cathode of V1.

4-19 V3 supplies a constant voltage to the cathode of V2 and to the meter circuit which is used as a reference voltage.

SECTION V MAINTENANCE

5-1 INTRODUCTION

5-2 This section contains information required to maintain the 230B Signal Generator Power Amplifier. The information covered is summarized below:

- a. TEST EQUIPMENT REQUIRED - Lists and describes test equipment necessary to perform the operations in this section.
- b. PERFORMANCE CHECKS - Verify proper operation of the 230B.
- c. ADJUSTMENT PROCEDURES - Used to adjust the 230B after repair.
- d. COMPONENT REPLACEMENT PROCEDURES - Describes step by step procedures for

major component replacement.

- e. TROUBLESHOOTING PROCEDURES - Aid in locating malfunctions.

5-3 TEST EQUIPMENT REQUIRED

5-4 Instruments required to perform the operations in this section are listed in Table 5-1. This table lists the type of instrument required, critical specifications, and recommended model or type. For operating instructions refer to the manual supplied with the equipment. If the equipment listed is not available, equipment which meets or exceeds the critical specifications may be used.

Table 5-1. Test Equipment Required

INSTRUMENT OR ACCESSARY TYPE	CRITICAL SPECIFICATIONS	RECOMMENDED INSTRUMENT OR ACCESSARY
Oscilloscope	Bandwidth: dc to 500kHz VERT sensitivity: 0.1V/cm HORIZ sensitivity: 1.0V/cm	HP 130C
Sweep Generator	Frequency range: 10-500MHz Markers: 1, 10, 50MHz Output: 1.0Vrms into 50 Ohms	Texscan VS50
Power Meter	Range: -20 to +10 dBm Accuracy: ±1% on +5 dBm Range	HP 431C
Xtal Detector	Frequency response flat from 10 to 500MHz	HP 423A
10 dB Attenuator	Frequency Range: dc to 12.4GHz Accuracy: ±0.5 dB Maximum input power: 2W average	HP 8491A Opt 10
20 dB Attenuator	Frequency range: dc to 12.4GHz Accuracy: ±0.5 db Maximum input power: 2W average	HP 8491A Opt 20
RF Voltmeter	Range: 1mV to 3V fullscale Frequency range: 10kHz to 1.2GHz	HP 3406A
DC Voltmeter	Range: 1mV to 1000V full scale Accuracy: ±1%	HP 412A

Table 5-1. Test Equipment Required (Continued)

INSTRUMENT OR ACCESSARY TYPE	CRITICAL SPECIFICATIONS	RECOMMENDED INSTRUMENT OR ACCESSARY
AC Voltmeter	Range: 1mV to 1000V full scale Frequency range: 40Hz to 1MHz Accuracy: $\pm 1\%$	HP 400E
Variable Transformer	Output: 115V $\pm 20\%$ or 230V $\pm 20\%$ Current: 2A	General Radio Type W10M3TA
Tuning Tool	6 in. length of 1/8 Nylon rod with blade tip	
Electronic Counter	10 - 500MHz	HP 5245L with 5253B Plug-in

5-5 PERFORMANCE CHECKS

5-6 The Performance Checks verify 230B operation within its rated specifications (see Section I, Table 1-1). They may be used:

- a. As part of incoming inspection
- b. As monthly routine reliability checks
- c. Before returning to normal service after being repaired
- d. For troubleshooting purposes

5-7 A sample Performance Check Test Card is included in this section. The card may be duplicated and completed during 230B Performance Checks to provide a permanent record.

5-8 FREQUENCY DIAL ACCURACY

5-9 To check the frequency dial accuracy, proceed as follows:

- a. Connect equipment as shown in Figure 5-1.

- b. Set sweep generator controls as follows:
 CENTER FREQUENCY See chart below
 SWEEP WIDTH CW
 ATTENUATION to maintain 5-10V output as read on 230B voltmeter.

c. Adjust 230B and sweep generator to frequencies listed in chart. The electronic counter should read between the limits shown.

230B DIAL FREQUENCY	COUNTER LIMITS
10MHz	9 - 11MHz
14MHz	12.6 - 15.4MHz
18MHz	16.2 - 19.8MHz
19MHz	17.1 - 20.9MHz
27MHz	24.3 - 29.7MHz
35MHz	31.5 - 38.5MHz
50MHz	45 - 55MHz
65MHz	58.5 - 71.5MHz
95MHz	85.5 - 104.5MHz
125MHz	112.5 - 137.5MHz
180MHz	162 - 198MHz
250MHz	225 - 275MHz
375MHz	337.5 - 412.5MHz
500MHz	450 - 550MHz

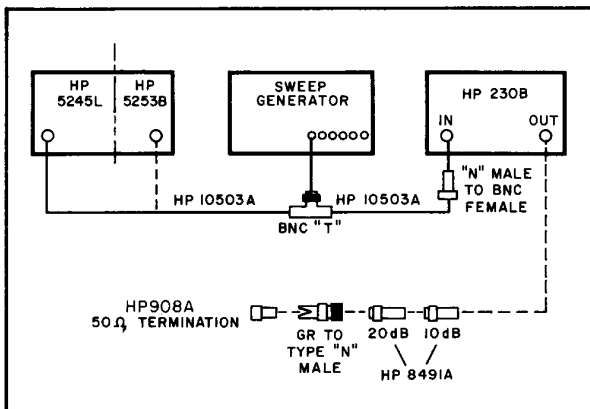

Figure 5-1. 230B Frequency Accuracy Test Setup

5-10 BANDWIDTH CHECK

- 5-11 To check the bandwidth, proceed as follows:
 - a. Connect equipment as shown in Figure 5-2.

CAUTION

Always disconnect the input to the 230B before disconnecting the output. Operating the instrument without a load may cause serious electrical damage.

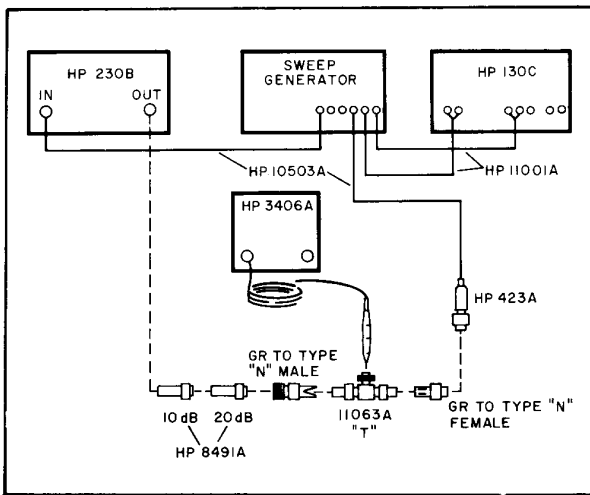

Figure 5-2. 230B Bandwidth Test Setup

- b. Set sweep generator controls as follows:
- | | |
|--------------------|-----------------|
| CENTER FREQUENCY | 10MHz (approx.) |
| ATTENUATION | 30dB |
| SWEEP WIDTH | CW |
| SWEEP RATE | 5-50Hz |
| SWEEP RATE vernier | FULL CW |
| Markers on | none |
- c. Set oscilloscope controls as follows:
- | | |
|------------------------|------------|
| VERTICAL INPUT | DC coupled |
| VERTICAL SENSITIVITY | 0.1V/cm |
| VERNIER | CAL |
| HORIZONTAL INPUT | DC coupled |
| HORIZONTAL SENSITIVITY | 1.0V/cm |
| VERNIER | CAL |

d. Set external RF voltmeter controls as follows:

RANGE 0.3 Volt

e. Set 230B controls as follows:

Range 10 - 18.5

FREQUENCY MHz 10

Voltmeter RANGE 30

f. Adjust 230B VERNIER for maximum output and sweep generator ATTENUATOR and RF vernier for 0.316 Volts on external RF voltmeter.

g. Change sweep generator controls as follows:

SWEEP WIDTH NARROW

Markers on 1MHz

h. Adjust sweep generator SWEEP WIDTH vernier until 1MHz equals 2cm on the oscilloscope graticule.

i. Using the oscilloscope VERTICAL POSITION control adjust for trace shown in Figure 5-3A.

j. Decrease sweep generator ATTENUATION 3dB.

k. The bandwidth between the two points where the waveform crosses the horizontal axis (see Figure 5-3B) should be 700kHz or 1.4cm minimum.

l. Using the above procedure, check several frequencies on each of the first three ranges. The 3dB bandwidth should be 700kHz minimum at any frequency.

m. On ranges 4, 5, and 6, repeat steps (a) through (l) using a SWEEP WIDTH setting of WIDE and adjusting 1MHz to equal 1cm in steps (g) and (h) respectively.

n. The 3dB bandwidth should be 700kHz minimum to 150MHz and 1.4MHz minimum from 150 to 500MHz.

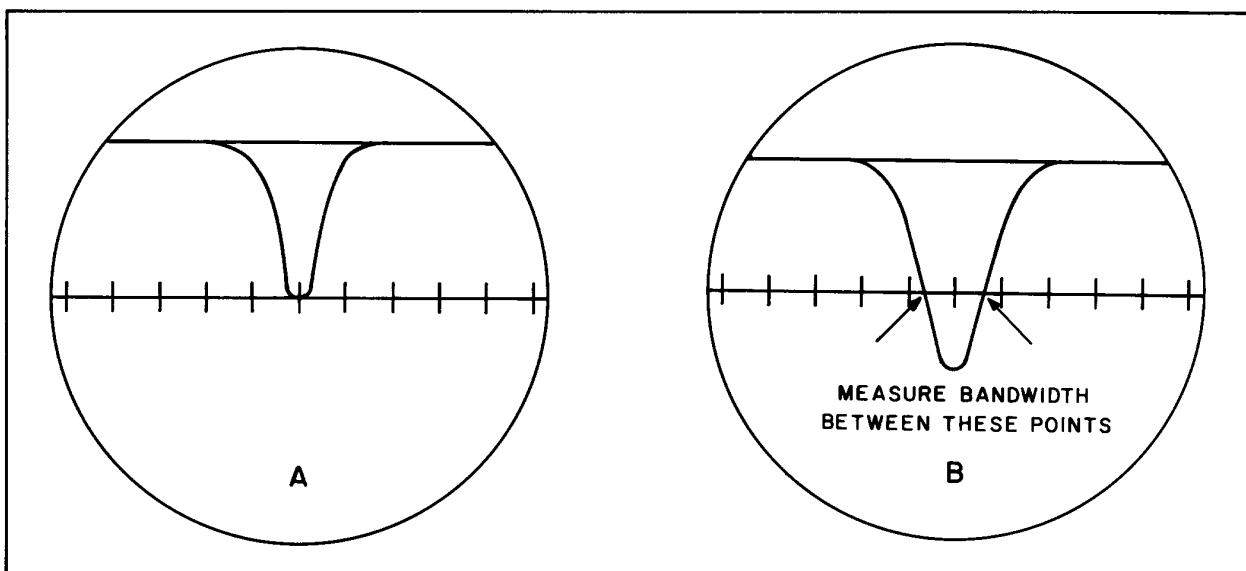

Figure 5-3. 230B Bandwidth Check Waveforms

o. Adjust sweep generator and 230B frequency controls from the low end to the high end of each range while noting the frequency on each range at which minimum output occurs.

NOTE

Adjust sweep generator ATTENUATION and SWEEP WIDTH controls as necessary for an on-screen oscilloscope display.

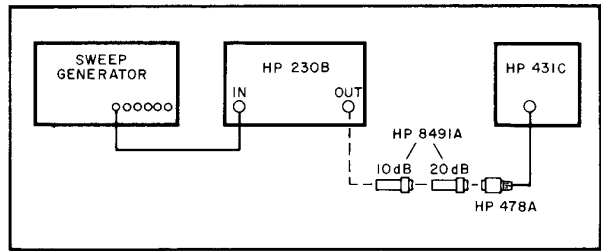

Figure 5-4. 230B Gain Check Setup

5-12 GAIN CHECK

- 5-13 To check the gain, proceed as follows:
- Connect equipment as shown in Figure 5-4.
 - Set 230B controls as follows:
 Range 10 - 18.5MHz
 FREQUENCY MHz Frequency of lowest output.
 - Set sweep generator controls as follows:
 CENTER FREQUENCY Same as 230B
 SWEEP WIDTH CW.
 - Set power meter controls as follows:
 RANGE +5dBm
 - Adjust sweep generator ATTENUATION and CENTER FREQUENCY controls for maximum output from the 230B as read on the power meter +5dBm range.
 - Adjust sweep generator RF VERNIER for a -2 reading on the power meter dBm scale, corresponding to +33dBm or 10V into 50 ohms.
 - Disconnect input to 230B and power meter.
 - Connect sweep generator RF OUT to power meter and note reading.
 - The 230B gain is equal to the algebraic difference between the 230B output and the sweep generator output and can be found by the following

method:

GAIN = +33 - (sweep generator output from step h)
 EXAMPLE: +33 - (-3) = +36dB
 +33 - (+5) = +28dB.

- The 230B gain should be 30dB minimum.
- Reconnect power meter and sweep generator to 230B.
 - Adjust auto transformer to 105Vac.
 - Repeat steps (e) through (i). The 230B gain should be 30dB minimum.
 - Repeat steps (a) through (m) for each frequency noted in Paragraph 5-11, step (o). The gain should be 30dB minimum from 10 to 125MHz, 27dB minimum from 125 to 250MHz, and 24dB minimum from 250 to 500MHz.

5-14 VOLTMETER ACCURACY

5-15 To check the voltmeter accuracy, proceed as follows:

- Connect test equipment as shown in Figure 5-5.
- Set 230B controls as follows:
 Range 10 - 18.5MHz
 FREQUENCY MHz 10
 Voltmeter RANGE 3
- Set sweep generator controls as follows:

230B VM RANGE	RF OUTPUT AS READ ON EXTERNAL RF VOLTMETER	230B METER LIMITS
3	0.1	0.9 - 1.1
3	0.2	1.8 - 2.2
3	0.3	2.7 - 3.3
10	0.3	2.7 - 3.3
10	0.4	3.6 - 4.4
10	0.5	4.5 - 5.5
10	0.6	5.4 - 6.6
10	0.7	6.3 - 7.7
10	0.8	7.2 - 9.0
10	0.9	8.1 - 9.9
10	1.0	9.0 - 11.0
30	1.0	9.0 - 11.0
30	1.2	10.8 - 13.2
30	1.5	13.5 - 16.5

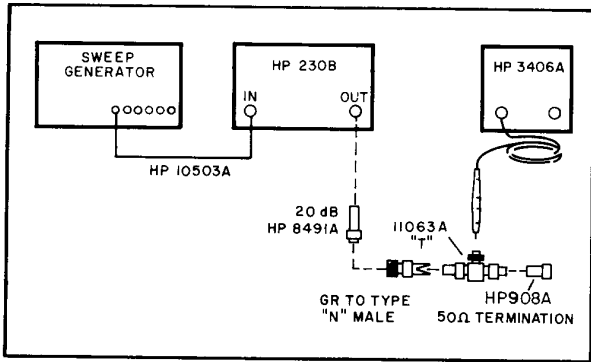

Figure 5-5. 230B Voltmeter Accuracy Setup

CENTER FREQUENCY 10MHz
SWEEP WIDTH CW

d. Adjust sweep generator ATTENUATION and RF VERNIER controls for 0.1 Volt on the external RF voltmeter. 230B voltmeter should read 0.89 to 1.10 Volts.

e. Adjust sweep generator for RF outputs listed below. The 230B voltmeter should indicate within limits listed.

f. Using the procedure in steps (d) and (e), any frequency may be checked against the limits listed in chart on previous page.

5-16 ADJUSTMENT PROCEDURES

5-17 The following adjustment procedures should be performed only if it has been determined by the Performance Checks in Paragraph 5-5 that the 230B is not within specifications. Tolerances associated with adjustments are given as aids to making the adjustments. These tolerances do not constitute a basis for qualification or acceptance of an instrument since no allowance has been made for temperature or aging effects. Qualification and overall performance should be based on the specifications listed in Section I, Table 1-1.

NOTE

Except where indicated, adjustments and tests are made at nominal line voltage.

5-18 PREPARATION FOR ADJUSTMENT

5-19 To obtain access to capacitor and coil slug adjustments it will be necessary to remove the top cover.

5-20 METER MECHANICAL ADJUSTMENT

5-21 This procedure adjusts the RF voltmeter

mechanical zero. Proceed as follows:

a. Turn on instrument and allow it to come up to normal operating temperature (about 20 minutes).

b. Turn the instrument off. Wait one minute for power supply capacitors to discharge completely.

c. Insert sharp pointed object (pen point or awl) into the small indentation near top of round black plastic disc located directly below meter face.

d. Rotate plastic disc clockwise (cw) until meter reads zero, then rotate ccw slightly in order to free adjustment screw from meter suspension. If pointer moves, repeat Steps c and d.

5-22 POWER SUPPLIES

5-23 This procedure checks and adjusts power supply voltages for the proper level. Proceed as follows:

a. Turn on 230B and allow 5 minutes warm up.

b. Measure heater voltages of V1, V2, and V3 with ac voltmeter. Voltage should be 5.9V ac ± 0.1 Vac.

c. Adjust R18, VOLT ADJ, for +320Vdc at V3 plate.

d. Adjust line voltage from 105 to 125Vac. +320V should not change more than ± 5.0 Vdc.

5-24 RF ADJUSTMENTS

5-25 The procedure for adjusting the 230B tuned circuits is given in the following paragraphs. For locations of adjustments, see Figure 5-6. The 230B may be initially adjusted with the amplifier box covers off; however, final adjustments must be performed with both covers securely in place. All adjustments are tuned for maximum output and

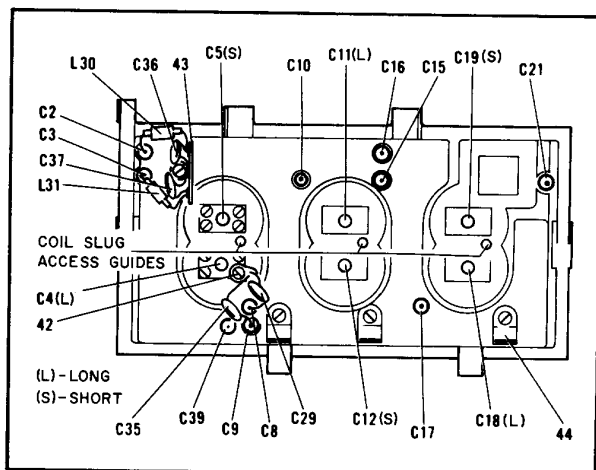

Figure 5-6. 230B Adjustments

proper frequency. Frequency accuracy is determined by the capacitor adjustments on range 6. The capacitors should not be moved during adjustment of the other five ranges.

5-26 After completing adjustment of a range and before proceeding to the next range, adjust the sweep generator and the 230B from one end of the range to the other while noting the frequency at which minimum output occurs. These points will be used during the gain check.

5-27 OSCILLOSCOPE CONTROL SETTINGS

5-28 Set oscilloscope controls as shown below. Once set, these controls will not be changed throughout the adjustment procedure. Should the waveform go off the screen, the sweep generator controls should be used to restore the waveform to normal.

5-29 250-500MHz ADJUSTMENT

5-30 The following procedure adjusts the 250-500 MHz range. Proceed as follows:

NOTE

The capacitor adjustments are performed on the 250-500MHz range only and should not be moved during subsequent range adjustments.

- a. Connect equipment as shown in Figure 5-2.
- b. Set sweep generator controls as follows:

CENTER FREQUENCY	500MHz
ATTENUATION	16dB
ALC	INT
SWEEP WIDTH	WIDE
SWEEP RATE vernier	CW
SWEEP RATE	5-50Hz
Markers on	50MHz
- c. Set 230B controls as follows:

Range	250-500MHz
FREQUENCY MHz	480MHz (approx)
Voltmeter RANGE	30
- d. Adjust sweep generator CENTER FREQUENCY until 500MHz marker is at the vertical center line of the oscilloscope graticule.

NOTE

If no waveform is visible, decrease sweep generator attenuation until waveform appears. As capacitors are adjusted, increase sweep generator attenuation to keep waveform on the screen.

e. Adjust C4, C11, and C18 until 500MHz marker is at peak of waveform and waveform is at maximum amplitude. Tighten locknuts finger tight.

f. Change equipment control settings as follows:

CENTER FREQUENCY	400MHz
230B FREQUENCY MHz	390MHz

g. Adjust sweep generator CENTER FREQUENCY until 400MHz marker is at the vertical center line of the oscilloscope graticule.

h. Using nylon tuning rod, adjust three coil slugs through holes in right side of amplifier box until 400MHz marker is at the waveform peak and the waveform is at maximum amplitude.

i. Change equipment controls as follows:

CENTER FREQUENCY	250MHz
230B FREQUENCY MHz	240MHz

j. Adjust C5, C12, and C19 until 250MHz marker is at the waveform peak and the waveform is at maximum amplitude. Tighten locknuts finger tight.

k. Repeat Steps b through j.

l. Tighten locknuts being careful not to turn adjusting screws.

m. Adjust sweep generator and 230B from the low end to the high end of the range while noting frequency at which lowest output occurs.

n. Perform the Bandwidth and Gain checks given in Paragraph 5-5 for Range 6.

5-31 125-250MHz ADJUSTMENT

5-32 The following procedure adjusts the 125-250 MHz range. Proceed as follows:

- a. Connect equipment as shown in Figure 5-2.
- b. Set sweep generator controls as follows:

CENTER FREQUENCY	250MHz
ATTENUATION	16dB
SWEEP WIDTH	WIDE
Markers on	50MHz
- c. Set 230B controls as follows:

Range	125-250MHz
FREQUENCY MHz	240MHz
- d. Adjust sweep generator CENTER FREQUENCY until 250MHz marker is at the vertical center line of the oscilloscope graticule.
- e. Adjust three coil slugs until 250MHz marker is at the waveform peak and the waveform is at maximum amplitude.
- f. Adjust sweep generator and 230B from the low end to the high end of the range while noting frequency at which lowest output occurs.
- g. Perform Bandwidth and Gain checks given in Paragraph 5-5 for the range being adjusted.

5-33 65-125MHz ADJUSTMENT

5-34 The following procedure adjusts the 65-125

MHz range. Proceed as follows:

- a. Connect equipment as shown in Figure 5-2.
- b. Set sweep generator controls as follows:
CENTER FREQUENCY 125MHz
ATTENUATION 23dB
Markers on 1, 10, 50
- c. Set 230B controls as follows:
Range 65-125MHz
FREQUENCY MHz 125MHz
- d. Repeat Steps 5-24 d, e, f, g, using 125MHz marker.

5-35 35-65MHz ADJUSTMENTS

5-36 This procedure adjusts the 35 to 65MHz range. Proceed as follows:

- a. Connect equipment as shown in Figure 5-2.
- b. Set sweep generator controls as follows:
CENTER FREQUENCY 65MHz
ATTENUATION 23dB
SWEEP WIDTH NARROW
Markers on 1, 10, 50MHz
- c. Set 230B controls as follows:
Range 35-65MHz
FREQUENCY MHz 65MHz
- d. Repeat Steps 5-24 d, e, f, and g using 65MHz marker.

5-37 18.5-35MHz ADJUSTMENT

5-38 This procedure adjusts the 18.5 to 35MHz range. Proceed as follows:

- a. Connect equipment as shown in Figure 5-2.
- b. Set sweep generator controls as follows:
CENTER FREQUENCY 35MHz
ATTENUATION 26dB
Markers on 1, 10, 50MHz
- c. Set 230B controls as follows:
Range 18.5-35MHz
FREQUENCY MHz 35
- d. Repeat Steps 5-24 d, e, f, g, using 35MHz marker.

5-39 10-18.5MHz ADJUSTMENT

5-40 This procedure adjusts the 10 to 18.5MHz range. Proceed as follows:

- a. Connect equipment as shown in Figure 5-2.
- b. Set sweep generator controls as follows:
CENTER FREQUENCY 18MHz
ATTENUATION 26dB
Markers on 1, 10MHz
- c. Set 230B controls as follows:
Range 10-18.5MHz
FREQUENCY MHz 18MHz
- d. Repeat Steps 5-24 d, e, f, and g using 18MHz marker.

5-41 VOLTMETER FULL-SCALE ADJUST

5-42 The following procedure adjusts the accuracy of the RF voltmeter. Proceed as follows:

- a. Connect equipment as shown in Figure 5-5.
- b. Set sweep generator controls as follows:
CENTER FREQUENCY 10MHz
ALC INT
SWEEP WIDTH CW
ATTENUATION 26dB
Markers on none
- c. Set external RF voltmeter controls as follows:
RANGE 1 Volt
- d. Set 230B controls as follows:
Range 10-18.5MHz
FREQUENCY MHz 10
Voltmeter RANGE 10
- e. Adjust 230B VERNIER control for maximum reading on the external RF voltmeter.
- f. Adjust sweep generator output for 1.0 Volt reading on external RF voltmeter.
- g. Adjust R125, METER SENS, for a full-scale reading on the 230B RF voltmeter 10 Volt range.

5-43 COMPONENT REPLACEMENT PROCEDURES

5-44 The following paragraphs give step by step procedures for replacing certain 230B components.

5-45 TUBE REPLACEMENT

5-46 Should it become necessary to replace one or more 2C39A tubes, they should be replaced with HP part number tubes only. These tubes have special reduced size heat radiators for reducing plate to ground capacitance. Proceed as follows:

- a. Remove instrument cover and amplifier box top and bottom covers.
- b. Referring to Figure 5-7, loosen the plate and grid ring clamps.
- c. Slide the plate ring clamp forward until it is free of the plate.
- d. Move 2C39A toward rear of amplifier box while moving cathode and filament connectors toward front of amplifier box until they disengage.
- e. Remove 2C39A.
- f. To replace 2C39A, reverse the above procedure.

NOTE

When installing 2C39A, be sure plate contact strap fingers are under plate ring clamp before it is tightened.

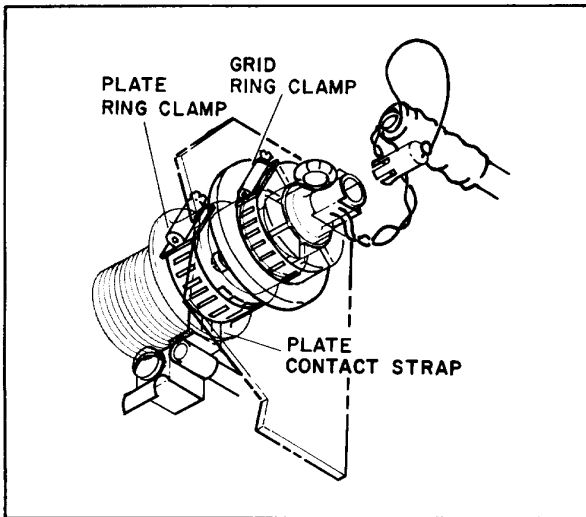

Figure 5-7. 2C39A Removal

5-47 DETECTOR DISASSEMBLY

5-48 Should it become necessary to replace the detector or part of the detector, the following steps should be used in sequence until desired part is removed. (Refer to Figure 5-8.)

- a. Unsolder choke from diode lead.
- b. Use solder sucker to remove all solder from the center of the feed-through capacitor.
- c. Unscrew detector spacer (3).
- d. Unsolder both diodes from the line connection (1) being careful not to let solder drip onto the line.
- e. Unscrew front panel connector and re-

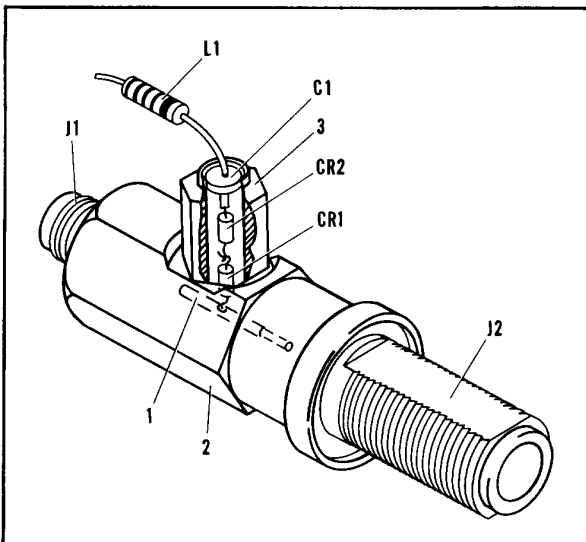

Figure 5-8. Detector Removal

move line from detector body (2).

- f. Unsolder line from TNC connector.
- g. To replace the components, reverse the above procedure.

5-49 CAPACITOR PISTON REPLACEMENT

5-50 The following procedure should be used when removing capacitor pistons. Pistons to be reused should be labeled and returned to their original positions. Proceed as follows:

- a. Remove instrument cover, right side bracket, and amplifier box top and bottom covers.
- b. Turn FREQUENCY MHz control to approximately mid-band.
- c. Loosen setscrews on turret adjacent to piston to be removed.
- d. Rotate turret on shaft to clear contacts while moving it toward rear of instrument.
- e. Remove hex nut and spacer from piston adjusting screw.
- f. Turn adjusting screw clockwise, through hinge pin, until threads disengage.
- g. Remove piston from inside amplifier box while exercising care not to damage the ground block spring fingers.
- h. To replace piston, reverse the above procedure.

CAUTION

When replacing pistons, do not allow the lip on the piston to catch on the glass assembly, as damage may result.

5-51 PISTON MECHANICAL ALIGNMENT

5-52 After removal and replacement of any capacitor pistons, it is necessary to mechanically align them to make electrical adjustment easier. These are approximate settings only and will be readjusted during electrical adjustment.

- a. Loosen setscrews adjacent to capacitor piston adjusting screws and set FREQUENCY MHz control to 13MHz.
- b. Center hinge plate pins and tighten setscrews.
- c. Set FREQUENCY MHz control near 250 MHz on range 5.
- d. Align C4, C11, and C18 (long) piston ends with inner edge of silvering on the glass by adjusting piston screws.
- e. Turn locknuts finger tight.
- f. Set FREQUENCY MHz control near 13.5 MHz.
- g. Align C5, C12, and C19 (short) piston ends with inner edge of silvering on the glass by adjusting piston screws.
- h. Perform RF adjustments of Paragraphs

5-16 through 5-34.

5-53 CAPACITOR GLASS TUBE REPLACEMENT

5-54 The following is a step by step procedure for replacing capacitor glass tubes. Proceed as follows:

- a. Remove instrument cover, right side bracket and amplifier box top and bottom covers.
- b. Using procedure in Paragraph 5-26, remove 2C39A tubes.
- c. Using the procedure in Paragraph 5-28, remove three pistons from hinge plate over glass tube to be replaced.
- d. Remove tension from hinge plate springs with long nosed pliers by moving end of spring sideways until it releases from under lip of amplifier box.
- e. Loosen setscrews retaining hinge plate shaft.
- f. Move hinge plate shaft toward rear of instrument and remove both shaft and hinge plate.
- g. Remove four ground block retaining screws and ground blocks.
- h. Unsolder glass tube from terminal inside amplifier box and remove from outside unit.

CAUTION

Before reassembling, clean any excess solder from contact straps and any glass tubes to be reused.

- i. Replace glass tube, ground block, four retaining screws and lockwashers.

CAUTION

Do not solder glass tube and contact strap until after ground block has been tightened or the glass tube may break.

- j. Assemble hinge plate and pistons by reversing Steps c through f above.
- k. Perform RF Adjustments of Paragraphs 5-16 through 5-34.

5-55 BLOWER MAINTENANCE

5-56 The 230B must always be used with the blower system in operation. For efficient cooling, the filter should be checked periodically and cleaned or replaced if necessary. To service:

- a. Remove filter element retainer and filter element.
- b. Wash filter element with water and mild detergent, or replace if necessary.

- c. Reinstall filter assembly.

5-57 LUBRICATION

5-58 After performing repairs, it may be necessary to lubricate the ground block wiper springs and the cam and cam follower. The ground block wiper springs should be lubricated with Supermil ASU Grease M-100 only. The cam and cam follower should be lubricated with "Molykote G".

Supermil ASU Grease M-100 is available from:

American Oil Company
555 Fifth Avenue
New York, New York

Molykote G is available from:

Alpha Molykote Corp.
Stanford, Connecticut

5-59 SELECTED COMPONENTS

5-60 The following paragraphs explain the procedures used to determine values of selected components used in the 230B.

5-61 C5, C12, and C19 - selected to compensate for slight variations in capacitance between different instruments.

5-62 Each piston is color coded according to its end diameter (see Figure 5-9). When replacing any of the above pistons, they should be replaced with the same color coded part according to Table 5-2. If the color code cannot be determined, the piston diameter may be checked with a micrometer.

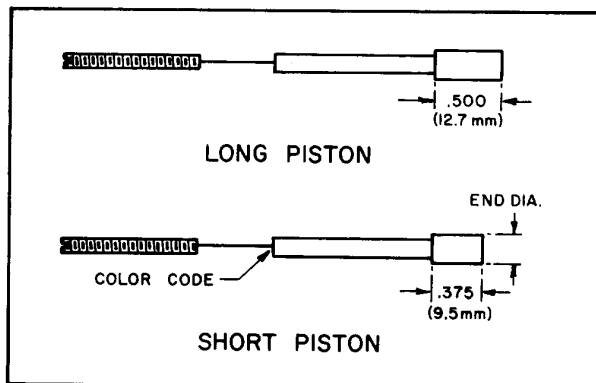

Figure 5-9. Piston Diameters

5-63 Should alignment difficulties be encountered after replacing any of the above pistons and/or

their glass assemblies, additional selection may be necessary. The most common indication is a serious drop in gain around 320MHz. This drop is caused by mis-tracking short pistons. To determine which piston is not tracking properly, proceed as follows:

- a. Adjust 230B to frequency at which the gain drops.
- b. Turn each piston slightly from its original position while noting if gain increases or decreases.
- c. If a significant increase in gain occurs when a piston is turned clockwise, a piston one size larger should be used. If the gain increases when piston is turned counterclockwise, a piston one size larger should be used.

5-64 TROUBLESHOOTING

5-65 The voltages shown on the schematic diagram in Figure 7-1 are typical operating voltages and can be used to aid in locating failures. The conditions for measurement are given in Section VII.

5-66 The Performance Checks in Table 5-2 may be

Table 5-2. Short Piston Color Codes

Part Number	Code/Color	End Diameter
00230-80041	1 Brown	0.1951 in.(4.956 mm)
00230-80042	2 Red	0.1952 in.(4.958 mm)
00230-80043	3 Orange	0.1953 in.(4.961 mm)
00230-80044	4 Yellow	0.1954 in.(4.963 mm)
00230-80045	5 Green	0.1955 in.(4.966 mm)

used to define problems such as low gain, frequency sensitive or intermittent failures. Causes of frequency sensitive and intermittent failures are too numerous to mention, but most problems in this area are caused by broken or worn contacts in the turret switching assembly. All contacts should be clean and free of grease or dirt. Turret contacts should make positive contact with their corresponding spring contact.

SECTION VI REPLACEABLE PARTS

6-1 INTRODUCTION

6-2 This section contains information for ordering replacement parts.

6-3 Table 6-4 lists parts in alpha-numerical order of the reference designators and provides the following information:

- a. Reference Designators. For abbreviations, refer to Table 6-1.
- b. Description. Refer to Table 6-2 for abbreviations.
- c. Total Quantity (TQ) used in the instrument; given only first time the part number is listed.
- d. Manufacturer's part number.
- e. Manufacturer's code number. Refer to Table 6-3 for manufacturer's name and address.
- f. Ⓢ Part Number.
- g. Recommended spare parts quantity (RS) for complete maintenance of one instrument during one year of isolated service.
- h. Parts not identified by a reference designator are listed at the end of Table 6-4 under Miscellaneous.

6-4 ORDERING INFORMATION

6-5 To order a replacement part, address order or inquiry to your local Hewlett-Packard sales office (see lists at rear of this manual for addresses).

6-6 Specify the following information for each part:

- a. Model and complete serial number of instrument.
- b. Hewlett-Packard part number.
- c. Circuit reference designator.
- d. Description.

6-7 To order a part not listed in Table 6-4, give a complete description of the part and include its function and location.

Table 6-1. Reference Designators

A = assembly	CR = diode
B = motor	DS = device, signaling (lamp)
C = capacitor	

Table 6-1. Reference Designators (Continued)

E = misc. electronic part	RT = thermistor
F = fuse	S = switch
J = jack	T = transformer
K = relay	V = vacuum tube, neon bulb, photocell, etc.
L = inductor	X = socket
M = meter	XF = fuseholder
P = plug	XDS = lampholder
Q = transistor	Z = network
R = resistor	

Table 6-2. Description Abbreviations

a = amperes	obd = order by description
c = carbon	p = peak
cer = ceramic	pc = printed circuit board
coef = coefficient	pf = picofarads = 10^{-12} farads
com = common	pp = peak-to-peak
comp = composition	ppm = parts per million
conn = connection	pos = position(s)
crt = cathode-ray tube	poly = polystyrene
dep = deposited	pot = potentiometer
elect = electrolytic	prv = peak reverse voltage
encap = encapsulated	rect = rectifier
f = farads	rot = rotary
fxd = fixed	rms = root-mean-square
GE = germanium	s-b = slow-blow
grd = ground(ed)	sect = section(s)
h = henries	Si = silicon
Hg = mercury	sil = silver
impq = impregnated	sl = slide
ins = insulation(ed)	td = time delay
K = kilo = 1000	TiO ₂ = titanium dioxide
lin = linear taper	tog = toggle
log = logarithmic taper	tol = tolerance
mA = milli = 10^{-3}	trim = trimmer
M = megohms	twt = traveling wave tube
ma = milliamperes	var = variable
μ = micro = 10^{-6}	w/ = with
mfr = manufacturer	W = watts
mtg = mounting	w/o = without
my = mylar	cmo = cabinet mount only
NC = normally closed	
Ne = neon	
NO = normally open	

Table 6-3. Code List of Manufacturers

CODE NO.	MANUFACTURER	ADDRESS	CODE NO.	MANUFACTURER	ADDRESS
00629	EBY Sales Co.	New York, N.Y.	07263	Fairchild Semiconductor Div. of	
00656	Aerovox Corp.	New Bedford, Mass.		Fairchild Camera and Instrument Corp.	
00853	Sangamo Electric Company,			Mountain View, Calif.	
	Ordill Division (Capacitors)	Marion, Ill.	07387	Birtcher Corp., The	Los Angeles, Calif.
01121	Allen Bradley Co.	Milwaukee, Wis.	07397	Sylvania Electric Products Inc.	
01255	Litton Industries, Inc.	Beverly Hills, Calif.		Mountain View Operations of	
				Sylvania Electronic Systems	
01281	TRW Semiconductors, Inc.	Lawndale, Calif.		Mountain View, Calif.	
01295	Texas Instruments, Inc. Semiconductor-		07716	I. R. C. Inc.	Burlington, Iowa
	Components Division	Dallas, Texas	07910	Continental Device Corp.	
01686	RCL Electronics, Inc.	Manchester, N.H.		Hawthorne, Calif.	
01930	Amerock Corp.	Rockford, Ill.	07933	Raytheon Mfg. Co., Semiconductor Div.	
02114	Ferroxcube Corp. of America			Mountain View, Calif.	
		Saugerties, N.Y.	08484	Breeze Corporations, Inc.	Union, N.J.
02606	Fenwal Laboratories	Morton Grove, Ill.	08530	Reliance Mica Corp.	Brooklyn, N.Y.
02660	Amphenol-Borg Electronics Corp.		08717	Sloan Company	Sun Valley, Calif.
		Broadview, Ill.	08730	Vemaline Products Co.	
				Franklin Lakes, N.J.	
02735	Radio Corp. of America, Commercial		08863	Nylomatic Corp.	Morrisville, Pa.
	Receiving Tube and Semiconductor Div.		09021	Airco Speer Electronic Components	
		Somerville, N.J.		Bradford, Pa.	
03508	G. E. Semiconductor Products Dept.		09182	Hewlett-Packard Co., New Jersey Div.	
		Syracuse, N.Y.		Berkeley Heights, N.J.	
03797	Eldema Corp.	Compton, Calif.	09353	C & K Components	Newton, Mass.
03877	Transitron Electronic Corp.		09922	Burndy Corp.	Norwalk, Conn.
		Wakefield, Mass.	11236	CTS of Berne, Inc.	Berne, Ind.
03888	Pyrofilm Resistor Co.	Cedar Knolls, N.J.	11237	Chicago Telephone of California, Inc.	
04009	Arrow, Hart and Hegeman Electric Co.			So. Pasadena, Calif.	
		Hartford, Conn.	11502	IRC Inc.	Boone, N.C.
04072	ADC Electronics, Inc.	Harbor City, Calif.	11711	General Instrument Corp., Semiconductor	
04213	Caddell-Burns Mfg. Co. Inc.			Prod. Group, Rectifier Div. Newark, N.J.	
		Mineola, N.Y.	12136	Philadelphia Handle Co., Inc.	
04404	Dymec Division of			Camden, N.J.	
	Hewlett-Packard Co.	Palo Alto, Calif.	12615	U. S. Terminals, Inc.	Cincinnati, Ohio
04713	Motorola, Inc., Semiconductor		12617	Hamlin Inc.	Lake Mills, Wisconsin
	Products Division	Phoenix, Arizona	12697	Clarostat Mfg. Co.	Dover, N.H.
05277	Westinghouse Electric Corp.		14493	Hewlett-Packard Co.,	
	Semi-Conductor Dept.	Youngwood, Pa.		Loveland Division	Loveland, Colo.
05347	Ultronix, Inc.	Grand Junction, Colo.	14655	Cornell-Dubilier Elec. Corp.	
05820	Wakefield Engr. Inc.	Wakefield, Mass.		Newark, N.J.	
06004	The Bassick Co.	Bridgeport, Conn.	14936	General Instrument Corp., Semiconductor	
06486	IRC, Inc. Semiconductor Div.	Lynn, Mass.		Prod. Group, Semiconductor Div.	
06540	Amathom Electronic Hardware Co., Inc.			Hicksville, N.Y.	
		New Rochelle, N.Y.	15909	Daven Div. of Thos. Edison Industries,	
06555	Beede Electrical Instrument Co., Inc.			Mc Graw Edison Co.	Livingston, N.J.
		Penacook, N.H.	16299	Corning Glass Works,	
06666	General Devices Co., Inc.			Electronic Components Div.	
		Indianapolis, Ind.		Raleigh, N.C.	
06751	Nuclear Corp. of America, Inc.		16758	Delco Radio Div. of General Motors	
	U. S. Semcor Div.	Phoenix, Arizona		Corp.	Kokomo, Ind.
06812	Torrington Mfg. Co., West Div.		17545	Atlantic Semiconductors, Inc.	
		Van Nuys, Calif.		Asbury Park, N.J.	
07137	Transistor Electronics Corp.		17803	Fairchild	Mountainview, Calif.
		Minneapolis, Minn.	19315	The Bendix Corp., Eclipse Pioneer Div.	
07138	Westinghouse Electric Corp.			Teterboro, N.J.	
	Electronic Tube Div.	Elmira, N.Y.	19701	Electra Mfg. Co.	Independence, Kan.

Table 6-3. Code List of Manufacturers (Continued)

CODE NO.	MANUFACTURER	ADDRESS	CODE NO.	MANUFACTURER	ADDRESS
21520	Fansteel Metallurgical Corp.	No. Chicago, Ill.	72699	General Instrument Corp.,	
22229	Union Carbide Corp., Linde Div.,		72765	Capacitor Div.	Newark, N.J.
22767	Kemet Dept., Mountain View, Calif.		72962	Drake Mfg. Co.	Chicago, Ill.
24446	ITT Semiconductors, A Division of			Elastic Stop Nut Corp. of America	Union, N.J.
24455	International Telephone & Telegraph Corp.	Palo Alto, Calif.	72982	Erie Technological Products, Inc.	Erie, Pa.
24655	General Electric Co.	Schenectady, N.Y.	73138	Helipot Div. of Beckman Instruments, Inc.	Fullerton, Calif.
26982	General Electric Co., Lamp Division		73168	Fenwal, Inc.	Ashland, Mass.
27014	Nela Park, Cleveland, Ohio		73293	Hughes Components Division of Hughes Aircraft Co.	Newport Beach, Calif.
28480	General Radio Co.	West Concord, Mass.	73445	Amperex Electronic Co., Div. of North American Phillips Co., Inc.	Hicksville, N.Y.
28520	Dynacool Mfg. Co. Inc	Saugerties, N.Y.	73506	Bradley Semiconductor Corp.	New Haven, Conn.
33173	National Semiconductor Corp.	Santa Clara, Calif.	73559	Carling Electric, Inc.	Hartford, Conn.
35434	Hewlett-Packard Co.	Palo Alto, Calif.	73734	Federal Screw Products, Inc.	Chicago, Ill.
37942	Heyman Mfg. Co.	Kenilworth, N.J.	73978	Hardwick Hindle Co., Memcor	
42190	G. E., Tube Dept.	Owensboro, Ky.	74193	Components Div.	Huntington, Ind.
43334	Lectrohm, Inc.	Chicago, Ill.	74545	Heinemann Electric Co.	Trenton, N.J.
44655	P. R. Mallory & Co., Inc.	Indianapolis, Ind.	74868	Harvey Hubbel, Inc.	Bridgeport, Conn.
46384	Muter Co.	Chicago, Ill.	74970	FXR Div. of Amphenol-Borg	
47904	New Departure-Hyatt Bearings Div.,		75042	Electronics Corp.	Danbury, Conn.
49956	General Motors Corp.	Sandusky, Ohio	75183	E. F. Johnson Co.	Waseca, Minn.
55026	Ohmite Manufacturing Co.	Skokie, Ill.	75382	International Resistance Co.	Philadelphia, Pa.
56289	Penn Engr.	Doylestown, Pa.	75915	Howard B. Jones Div., of Cinch Mfg. Corp. (Use 71785)	New York, N.Y.
58474	Polaroid Corp.	Cambridge, Mass.	76381	Kulka Electric Corp.	Mt. Vernon, N.Y.
61637	Raytheon Mfg. Co., Microwave and Power Tube Div.	Waltham, Mass.	76493	Littlefuse, Inc.	Des Plaines, Ill.
63743	Simpson Electric Co.	Chicago, Ill.	76530	Minnesota, Mining & Mfg. Co.	St. Paul, Minn.
70563	Sprague Electric Co.	North Adams, Mass.	76930	J. W. Miller Co.	Los Angeles, Calif.
70901	Superior Electric Co.	Bristol, Conn.	76854	Cinch	City of Industry, Calif.
70903	Union Carbide Corp.	New York, N.Y.	77068	Oak Manufacturing Co.	Crystal Lake, Ill.
71218	Ward-Leonard Electric Co.	Mt. Vernon, N.Y.	77147	Bendix Corp., Bendix-Pacific Div.	No. Hollywood, Calif.
71279	Amperite Co., Inc.	Union City, N.J.	77221	Patton Mac Guyer Co.	Providence, R.I.
71400	Beemer Engrg. Co.	Fort Washington, Pa.	77252	Phaostron Instrument and Electronic Co.	South Pasadena, Calif.
71450	Belden Mfg. Co.	Chicago, Ill.	77342	Philadelphia Steel and Wire Corp.	Philadelphia, Pa.
71468	Bud Radio, Inc.	Willoughby, Ohio	77630	American Machine and Foundry,	
71590	Cambridge Thermionic Corp.	Cambridge, Mass.	77764	Potter and Brumfield Div.	Princeton, Ind.
71700	Bussmann Mfg. Div. of		78189	TRW Electronics, Components Div.	
71707	Mc Graw-Edison Co.	St. Louis, Mo.	78452	Resistance Products Co.	Harrisburg, Pa.
71744	CTS Corporation	Elkhart, Ind.	78488	Shakeproof Div. of Illinois Tool Works	Elgin, Ill.
71785	I. T. T. Cannon Electric Inc.	Los Angeles, Calif.	78526	Everlock Chicago, Inc.	Chicago, Ill.
71984	Centralab Div. of Globe Union, Inc.	Union, N.J.	78526	Stackpole Carbon Co.	St. Marys, Pa.
72136	The Cornish Wire Co.	New York, N.Y.	78553	Stanwyck Winding Co., Inc.	Newburgh, N.Y.
72619	Coto-Coil	Providence, R.I.		Tinnerman Products, Inc.	Cleveland, Ohio
	Chicago Miniature Lamp Works	Chicago, Ill.			
	Cinch Mfg. Co.	Chicago, Ill.			
	Dow Corning Corp.	Midland, Mich.			
	Electro-Motive Mfg. Co. Inc., The	Willimantic, Conn.			
	Dialight Corp.	Brooklyn, N.Y.			

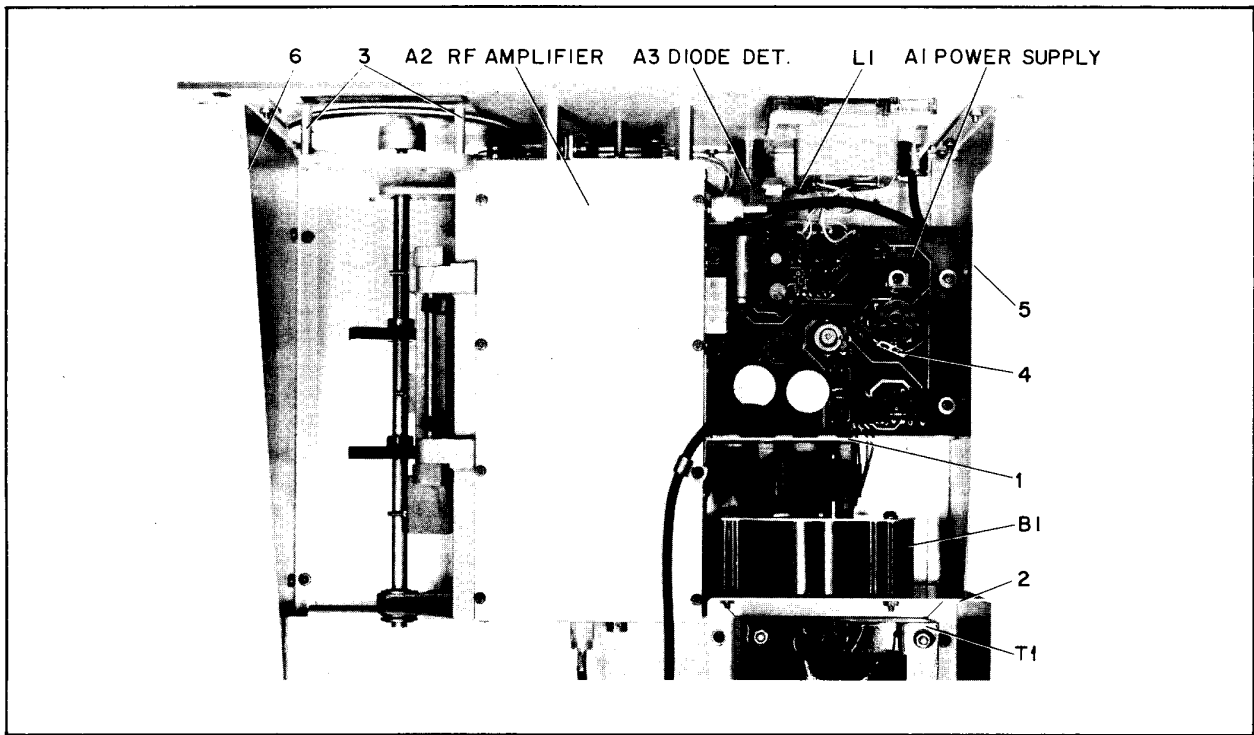



Figure 6-1. Overall Component Location

ITEM NO.	DESCRIPTION	TQ	MFR. PART NO.	MFR. CODE	HP PART NO.	RS
1-1	Mounting Bracket, Fan Motor	1		09182	00230-01016	-
1-2	Bracket, Fan Mounting	1		09182	00230-01006	-
-	Spacer, P.C. Board	1	2112	83330	0380-0786	1
-	Panel, Front	1		09182	00230-01004	-
-	Knob, Frequency (Black)	1		09182	0370-0028	1
-	Knob, Meter Range	1		09182	0370-0112	1
-	Knob, Frequency, Range	1		09182	0370-0035	1
-	Knob, Vernier	1		09182	0370-0025	1
-	Handle, 7"	2		09182	5020-5584	1
-	Meter, Bezel	1		09182	4040-0296	1
-	Spring, Meter	4		09182	1460-0256	1
1-3	Spacer, Fiducial (spacer holding fiducial to casting)	1		09182	00250-20115	
1-4	Clamp, Tube	1	926C	07387	1400-0196	1
-	Cabinet Assembly	1		09182	00230-61001	-
1-5	Bracket, Left Side	1		09182	00230-01001	-
1-6	Bracket, Right Side	1		09182	00230-01002	-
-	Filter Assembly, Air	1		09182	5060-0878	-
-	Chassis	1		09182	00230-01005	-
-	Cover, Bottom	1		09182	00230-01003	-
-	Foot, Rubber	4	4-1/2 CB	76385	0403-0045	1
-	Holder, Fuse	1	342014	75915	1400-0084	1
-	Lock Washer Helical Spring Type	-		09182	2190-0086	-
-	Nut, Knurled 5/8 x 24 thread 3/4 in. O.D.	-		09182	0590-0011	-

Table 6-4. Replaceable Parts

REF. DESIG.	DESCRIPTION	TQ	MFR. PART NO.	MFR. CODE	 PART NO.	RS
CHASSIS ELECTRICAL PARTS						
B1	Motor, Fan			09182	3160-0215	
C1	fxd, ceramic 10,000pF $\pm 20\%$ 250Vac	1	41C157-CDH	56289	0150-0123	1
C2, C3	fxd, ceramic 0.002 μ f $\pm 20\%$ 250Vac	2	19C253	56289	0160-2108	1
DS1	Light, Indicator (Red)	1	599-124	72765	1450-0048	1
F1 (115Vac)	Fuse, 2A 125V S.B.	1	313.002	75915	2110-0006	5
F1 (230Vac)	Fuse, 1A 125V S.B.	1	313.001	75915	2110-0007	5
M1	Meter, 0-3, 0-10, 0-30 RF Volts	1		09182	1120-0413	1
P6	AC Power Connector	1		09182	1251-2357	1
R1	fxd, comp 43K Ω $\pm 5\%$ $\frac{1}{2}$ W	1	EB-4335	01121	0686-4335	1
S1	Toggle Switch, SPST	1	80994-HB	04009	3101-0001	1
S2	Slide Switch, DPDT	1	G326-0001	79727	3101-0033	1
S3	Meter Switch	1		09182	3100-1612	1
T1	Transformer, Power	1		09182	00230-80501	1
W1	Input Cable Assembly	1		09182	00230-61004	1
W7	AC Power Cord	1		09182	8120-1348	1
A1	Main P. C. Board (Loaded)	1		09182	00230-61020	1
A1C1	fxd, ceramic 0.02 μ f $\pm 20\%$ 2000WVdc	1	41C321-CDH	56289	0160-2569	1
A1C2	fxd, elect. 40 μ f 500WVdc +50 -10%	2	68D10031-DFP	56289	0180-2226	1
A1C3	fxd, mylar 0.1 μ f $\pm 10\%$ 200WVdc	1	192P10492-PTS	56289	0160-0168	1
A1C4	fxd, elect. 10 μ f 450WVdc +50 -10%	1		09182	0180-1944	1
A1C6	fxd, ceramic 0.02 μ f 25WVdc	1	5835Y5U203Z	72982	0160-2605	1
A1C7	fxd, elect. 40 μ f 500WVdc +50 -10%	1	68D10031-DFP	56289	0180-2226	1
A1CR1-CR4	Diode, Si. 800PIV	4	34534	02735	1901-0388	4
A1CR5	Diode, Si.	1		09182	1901-0040	1
A1CR7	Diode, Si. 50PIV	1		09182	1901-0049	1
A1Q1	SS NPN Si.	1		09182	1854-0087	1
A1Q2	SS NPN Si.	1		09182	1854-0244	1
A1R1	fxd, comp 180K Ω $\pm 5\%$ $\frac{1}{2}$ W	1	EB-1845	01121	0686-1845	1
A1R2	fxd, comp 56K Ω $\pm 5\%$ $\frac{1}{2}$ W	1	EB-5635	01121	0686-5635	1
A1R3	fxd, met. ox. 15K Ω $\pm 5\%$ 4W ± 250 ppm	1	Type PMF-4	07716	0770-0006	1
A1R4	fxd, film 261K Ω $\pm 1\%$ 1/8W ± 100 ppm	1	Type CEA	07716	0698-3455	1
A1R5	fxd, film 200K Ω $\pm 1\%$ 1/8W ± 100 ppm	1	Type CEA	07716	0757-0472	1
A1R6	fxd, comp 27K Ω $\pm 5\%$ $\frac{1}{2}$ W	1	EB-2735	01121	0686-2735	1
A1R7	fxd, met. ox. 68K Ω $\pm 5\%$ 1W ± 200 ppm	1	L32	07716	0761-0083	1
A1R8	fxd, met. ox. 5.60K Ω $\pm 5\%$ 4W ± 250 ppm	1	Type PMF-4	07716	0770-0011	1
A1R9	fxd, comp 300K Ω $\pm 5\%$ $\frac{1}{2}$ W	1	EB-3045	01121	0686-3045	1
A1R10	fxd, comp 2M Ω $\pm 5\%$ $\frac{1}{2}$ W	1	EB-2055	01121	0686-2055	1
A1R11	fxd, comp 1.5M Ω $\pm 5\%$ $\frac{1}{2}$ W	1	EB-1555	01121	0686-1555	1
A1R12	fxd, comp 4.7K Ω $\pm 5\%$ $\frac{1}{2}$ W	2	EB-4725	01121	0686-4725	1
A1R13	var. ww 10K Ω $\pm 10\%$	1	Type 500	75042	2100-1776	1
A1R14	fxd, comp 4.7K Ω $\pm 5\%$ $\frac{1}{2}$ W	1	EB-4725	01121	0686-4725	1
A1R15	fxd, film 33.2K Ω $\pm 1\%$ 1/8W ± 100 ppm	1	Type CEA	07716	0757-0454	1
A1R16	fxd, film 107K Ω $\pm 1\%$ 1/8W ± 100 ppm	1	Type CEA	07716	0698-4515	1
A1R17	fxd, film 340K Ω $\pm 1\%$ 1/8W ± 100 ppm	1	Type CEA	07716	0698-4536	1
A1R18	var. ww 100K Ω $\pm 30\%$	1		09182	2100-0095	1
A1R19	fxd, comp 10K Ω $\pm 5\%$ $\frac{1}{2}$ W	1	EB-1035	01121	0686-1035	1
A1R21	fxd, comp 100 Ω $\pm 5\%$ $\frac{1}{4}$ W	1	CB-1015	01121	0683-1015	1
A1V1	Electron Tube, Dual Triode	1	6AS7G	02735	1932-0018	1
A1V2	Electron Tube, Pentode	1	6AU6	02735	1923-0021	1
A1V3	Electron Tube	1	OA2	02735	1940-0004	1
A1VR6	Diode, Zener 43.2V $\pm 2\%$	1		09182	1902-3327	1

ITEM NO.	DESCRIPTION	TQ	MFR. PART NO.	MFR. CODE	Ⓟ PART NO.	RS
	PC BOARD 00230-61020 MECHANICAL PARTS					
-	Bracket, P.C. Board	2		09182	00230-01015	1
-	Heat Dissipator, Semiconductor	1	NF-207	05820	1205-0033	1
-	Socket, Tube (V1)	1	101-04-11-100	71785	1200-0084	1
-	Socket, Tube (V2, V3)	2	111-51-11-069	71785	1200-0053	2
-	Tube Clamp (V1)	1		09182	1400-0196	1
-	Spacer, Tube Clamp	1		09182	0380-0786	1

REF. DESIG.	DESCRIPTION	TQ	MFR. PART NO.	MFR. CODE	Ⓢ PART NO.	RS
A2	Amplifier Box Assembly (Loaded)	1		09182	00230-61002	1
A2C1	fxd, mica 1000pf ±10%	3		09182	0160-0428	1
A2C2, C3	fxd, ceramic feed-thru, 1000pf +100 -0%, 500WVdc	10	FB2B-102W.	01121	0160-0345	2
A2C4, 5, 11, 12, 18, 19	See Paragraph 5-59	-	-	-	-	-
A2C6	fxd, ceramic 1000pf -20, +80%, 500WVdc	3	SB4A	01121	0160-0420	1
A2C7	fxd, mica 1000pf ±10%			09182	0160-0428	
A2C8-C10	fxd, ceramic feed-thru, 1000pf +100 -0%, 500WVdc		FB2B-102W	01121	0160-0345	
A2C13	fxd, ceramic 1000pf -20, +80%, 500WVdc		SB4A	01121	0160-0420	
A2C14	fxd, mica 1000pf ±10%			09182	0160-0428	
A2C15-C17	fxd, ceramic feed-thru, 1000pf, +100 -0%, 500WVdc		FB2B-102W	01121	0160-0345	
A2C20	fxd, ceramic 1000pf -20, +80%, 500WVdc		SB4A	01121	0160-0420	
A2C21	fxd, ceramic feed-thru, 1000pf, +100 -0%, 500WVdc		FB2B-102W	01121	0160-0345	
A2C22-28	NOT ASSIGNED	-	-	-	-	-
A2C29, 35, 36-38	fxd, ceramic 4700pf ±20%	5	DD472	71590	0160-0472	1
A2C39	fxd, ceramic feed-thru, 1000pf, +100 -0%, 500WVdc		FB2B-102W	01121	0160-0345	
A2CR1, 5, 6	Diode, Si. 50PIV	3		09182	1901-0049	3
A2J1	NOT ASSIGNED	-	-	-	-	-
A2J2, 3	RF Connector, TNC	2		09182	1250-0794	1
A2L9, 18, 27, 30, 31	Choke Assembly	5		09182	00230-80006	1
A2L34	Choke	1		09182	00230-60052	1
A2L35	Choke	1		09182	00230-60051	1
A2L36	Choke	1		09182	00230-60050	1
A2V1-V3	Electron Tube, 2 C39A, Triode	3		09182	1921-0046	3
A2W2	Output Cable	1		09182	00230-61005	1
A2Z1	Turret Assembly	2		09182	00230-60021	2
A2Z2	Turret Assembly	1		09182	00230-60026	1
A2Z3	Turret Assembly			09182	00230-60021	
A3	RF Detector (Loaded)	1		09182	00230-61003	1
A3C1	fxd, cer. feed-thru 220pf ±20% 300Vdc	1	FW5N-2212	01121	0160-2603	1
A3CR1, CR2	Diode	2		09182	1901-0518	2
A3J1	RF Connector (with cable)	1	2684-3	95712	1250-2041	1
A3J2	RF Connector, TNC	1	8306-1	95712	1250-0794	1
A3L1	Inductor, shielded 100μh ±10%	1	15S-101K	82142	9100-2562	1
	RF DETECTOR MECHANICAL PARTS (Refer to Figure 5-8)					
	Detector line	1		09182	00230-21007	1
	Detector body	2		09182	00230-21006	1
	Detector spacer	3		09182	00230-21008	1

ITEM NO.	DESCRIPTION	TQ	MFR. PART NO.	MFR. CODE	Ⓢ PART NO.	RS
	RF BOX MECHANICAL PARTS					
2-1	RF Connector	1	8306-1	95712	1250-0794	1
2-2	Lock Washer	-	1920-02	78189	2190-0016	-
2-3	Machine Screw	-		09182	2200-0145	-
2-4	Lock Washer	-		09182	2190-0086	-
2-5	Block & Contact Ass'y (see Fig. 6-7)	3		09182	-	1
2-6	NOT ASSIGNED	-	-	-	-	-
2-7	Block & Contact Ass'y (see Fig. 6-5)	3		09182	-	1
2-8	Turret Assembly (Z1,Z3)	2		09182	00230-60021	1
2-9	Machine Screw	-		09182	2200-0141	-
2-10	Screw, Tapping	-		09182	0624-0077	-
2-11	Machine Screw	-		09182	2200-0139	-
2-12	Tube Clamp	3		09182	00230-20009	1
2-13	Machine Screw	-		09182	2200-0145	-
2-14	Clamp, Hose	6	QS700-M10H	08484	1400-0720	2
2-15	Terminal, Solder Lug	-	2522-04-00	78189	0360-0374	-
2-16	Hex Nut	-		09182	2260-0009	-
2-17	Line Coupling	3		09182	00230-80001	1
2-18	Turret Assembly (Z2)	1		09182	00230-60026	1
2-19	NOT ASSIGNED	-	-	-	-	-
2-20	Set Screw	-		09182	3030-0033	-
2-21 through						
2-25	NOT ASSIGNED	-	-	-	-	-
2-26	Machine Screw	-		09182	2510-0107	-
2-27	Lock Washer	-	2-618-BC	78452	2190-0008	-
2-28	Screw, Tapping	-		09182	0624-0208	-
2-29	NOT ASSIGNED	-	-	-	-	-
2-30	Lock Washer	-	2-820-BC	78452	2190-0010	-
2-31	Detent Bracket	1		09182	00230-01010	1
2-32	Machine Screw	-		09182	2510-0103	-
2-33	Detent, Spring	2		09182	5000-3001	1
2-34	Leaf, Spring	1		09182	1460-0209	1
2-35	Machine Screw	-		09182	2360-0197	-
2-36	Spacer, Internally Threaded Hex	2	8583-A-0832	06540	00230-20038	1
2-37	Set Screw	-		09182	3030-0001	-
2-38	Roller Detent	1		09182	00230-20065	1
2-39	Wheel Detent	1		09182	00230-20058	1
2-40	Shaft, Amplifier Box	1		09182	00230-20016	1
2-41	Retaining Ring	1	5133-25-S-MD	79136	0510-0083	1
2-42	Bearing, Ball	2	77R4LR3FY	43334	1410-0231	1
2-43	Washer, Flat	-		09182	3050-0273	-
2-44	Bracket, Amplifier Box	1		09182	00230-01009	1
2-45	Wiper, Rotor	5		09182	5000-4912	-
2-46	Line, Matching	1		09182	00230-00014	1
2-47	Glass cloth insulation lgth as req'd	1	27	76381	0460-0283	1
2-48	Block & Contact Ass'y (see Fig. 6-8)	3		09182	-	1
2-49	RF Connector	1	8306-1	95712	1250-0794	1
2-50	Machine Screw	-		09182	0520-0131	-
2-51	NOT ASSIGNED	-	-	-	-	-
2-52	Waveguide Assembly	2		09182	00230-60016	1
2-53	Bushing, Insulating	1	N5330-1	08863	1410-0232	1
2-54	Grounding Strip	3		09182	00230-00053	1
2-55	Machine Screw	-		09182	2200-0147	-
2-56	Clip, Earless	3	123.002	75915	1400-0175	1
2-57	Plug, Terminal	3		09182	00230-20013	1
2-58	Block & Contact Ass'y (see Fig. 6-6)	3		09182	-	1
2-59	Terminal, Standoff	2	G-4777-10	12615	0340-0098	1

ITEM NO.	DESCRIPTION	TQ	MFR. PART NO.	MFR. CODE	Ⓢ PART NO.	RS
2-60	Terminal, Solder Lug	-	4029	77147	0360-0002	-
2-61	Machine Screw	-		09182	2200-0147	-
2-62	Lock Washer	-		09182	2190-0086	-
2-63	NOT ASSIGNED	-	-	-	-	-
2-64	Lock Washer	-		09182	2190-0086	-
2-65	Machine Screw 4-40 x 1/2 ph posi.	-		09182	0624-0026	-
2-66	NOT ASSIGNED	-	-	-	-	-
2-67	Cover, RF Amplifier	2		09182	00230-20004	-
2-68	Shield, Screen	2		09182	00230-00007	1
2-69	Screw, Tapping	-		09182	0624-0208	-
2-70	Machine Screw 8-32 x 3/8" ph posi.	-		09182	2510-0103	-
2-71	Spacer, Shaft	5		09182	5020-2210	1
2-72	Terminal, Standoff	1	X1581	71279	0340-0097	1
2-73	Washer, Lock	-	1902-00	78189	2190-0014	-

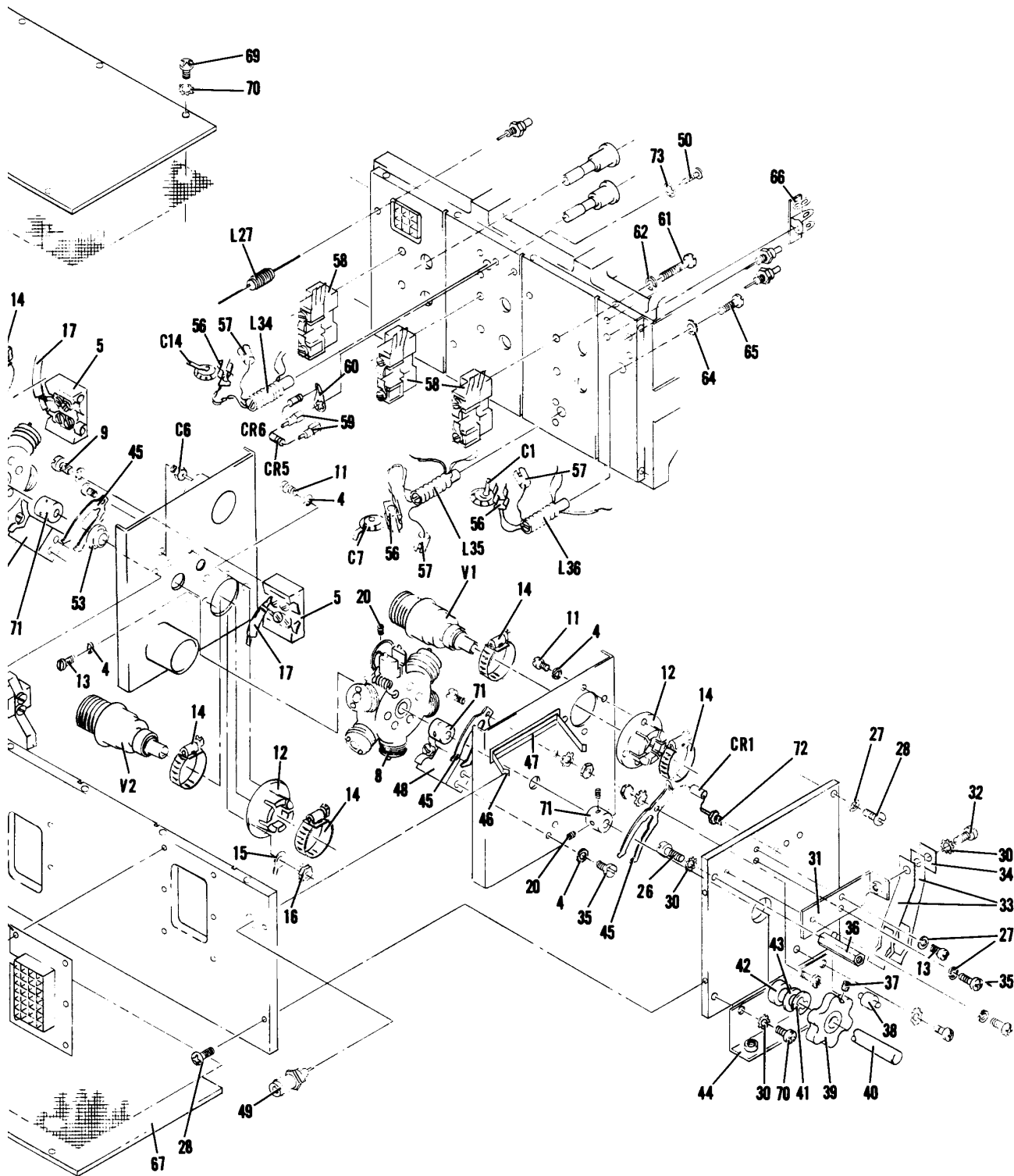
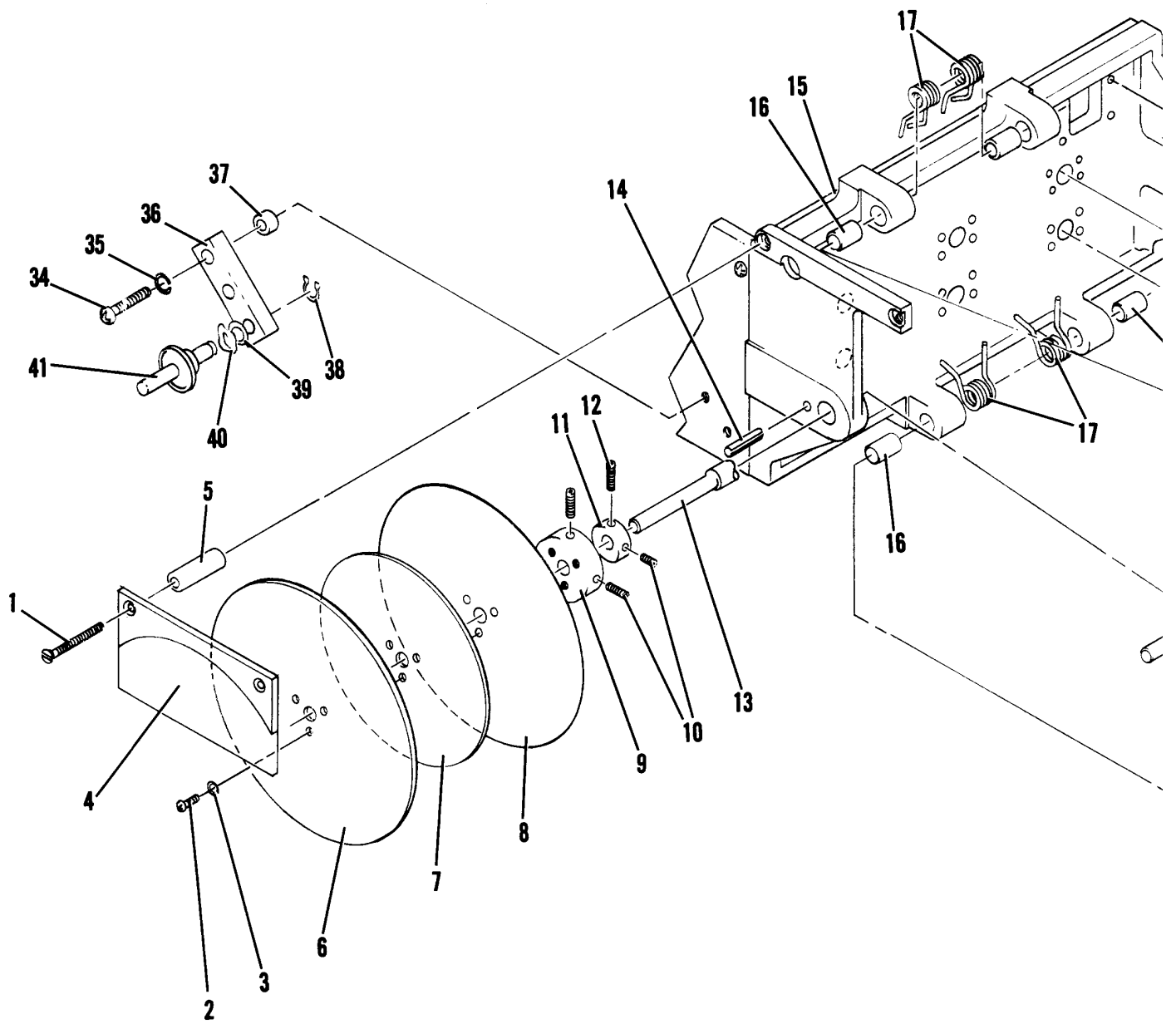

Figure 6-2. RF Amplifier Box Assembly

ITEM NO.	DESCRIPTION	TQ	MFR. PART NO.	MFR. CODE	Ⓢ PART NO.	RS
	RF BOX MECHANICAL PARTS					
3-1	Machine Screw 1.5 in. lg. #4-40 thd	-		09182	2200-0176	-
3-2	Machine Screw 0.5 in. lg. #4-40 thd	-		09182	2200-0147	-
3-3	Lock Washer Helical Spring Type	-		09182	2190-0086	-
3-4	Fiducial	1		09182	00230-20039	1
3-5	Spacer	2		09182	00250-20115	1
3-6	Dial	1	1868-30-0010	83835	0350-0029	1
3-7 to 3-9	Disc Drive Assembly	1		09182	00230-60012	1
3-7	Spacer	1		09182	00230-00042	1
3-8	Disc Drive	1		09182	00230-00041	1
3-9	Hub	1		09182	00230-20018	1
3-10	Set Screw .188 in. lg. #6-32 thd.	-		09182	3030-0033	-
3-11	Collar	1		09182	00230-20050	1
3-12	Set Screw .5 in. lg. #6-32 thd.	-		09182	3030-0143	-
3-13	Cam Shaft	1		09182	00230-20082	1
3-14	Rollpin .187 dia. 7/8 in. lg.	1	79-040-187-0875	72962	1480-0149	1
3-15	Pl. Side R. H.	1		09182	00230-21002	1
3-16	Bearing, Sleeve	4	AA-307-3	70901	1410-0156	1
3-17	Torsion Spring	4		09182	00230-80023	1
3-18	Waveguide Assembly	1		09182	00230-60014	1
3-19	Machine Screw .25 in. lg. #4-40 thd	-		09182	2200-0139	-
3-20	Washer, Flat 7/8 OD .391 ID	-		09182	3050-0297	-
3-21	Washer, Spring	-		09182	3050-0316	-
3-22	Ring, Retaining	1	5133-37-S-MD	79136	0510-0235	1
3-23	Bushing & Glass Assembly	6		09182	00230-60023	2
3-24	Piston Ass'y. (see Paragraph 5-35)	6		09182	-	2
3-25	Grounding Wiper Pl.	6		09182	00230-20068	2
3-26	Plate Hinge	1		09182	00230-20043	1
3-27	Shaft, Hinge Plate Pivot	1		09182	00230-20005	1
3-28	Pin Hinge Plate Mounting	3		09182	00230-20069	1
3-29	Spacer	3		09182	00230-20001	1
3-30	Hex Nut 6-32 x 1/4 x 3/32 in.	-		09182	2420-0007	-
3-31	Bearing, Sleeve	2	AA-507-4	70901	1410-0157	1
3-32	Cam RF Translator	2		09182	00230-40001	1
3-33	Set Screw #6-32 thd. .188 in. lg.	-		09182	3030-0033	-
3-34	Machine Screw #8-32 thd. .875 lg.	-		09182	2510-0015	-
3-35	Lock Washer Helical Spring Type	-		09182	2190-0087	-
3-36	Plate Support	1		09182	00230-00006	1
3-37	Spacer, Sleeve	1		09182	00230-20003	1
3-38	Retaining Ring	1	5100-25-S-MD	79136	0510-0005	1
3-39	Flat Washer	-		09182	3050-0017	-
3-40	Washer, Spring	-		09182	3050-0272	-
3-41	Vernier Drive Assembly	1		09182	00230-60013	1
3-42	Terminal, Solder Lug	-	2102-04-00	78189	0360-0371	-
3-43	Terminal Board	1	1520-A	71785	0360-0364	1
3-44	Clamp, Plastic	3	HP-4N	09922	1400-0126	1



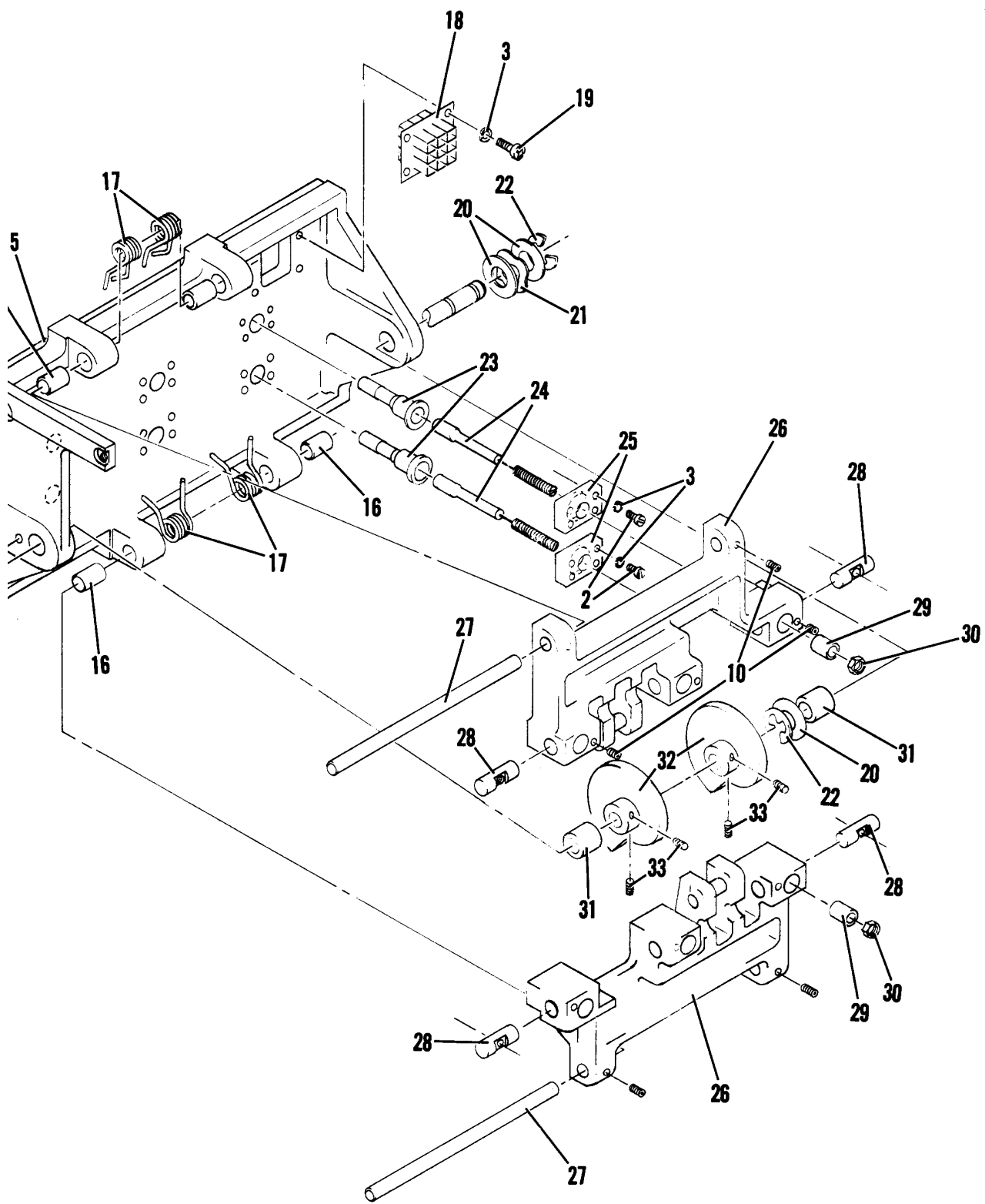

Figure 6-3. Hinge Plate Assembly

ITEM NO.	DESCRIPTION	TQ	MFR. PART NO.	MFR. CODE	Ⓟ PART NO.	RS
CONTACT BLOCK PARTS						
4-1	NOT ASSIGNED	-	-	-	-	-
4-2	Lock Washer	-		09182	2190-0086	-
4-3	Block, Contact	3		09182	00230-20010	1
4-4	Contact, Turret	3		09182	00230-60043	1
4-5	Machine Screw	-		09182	2200-0137	-
5-1	Block, Contact	3		09182	00230-20011	1
5-2	Plug, Terminal	3		09182	00230-20013	1
5-3	Contact Spring	3		09182	00230-00035	1
5-4	Machine Screw 4-40 x $\frac{1}{4}$ Binder Hd.	-		09182	-	-
5-5	Contact, Spring	3		09182	00230-00036	1
6-1	Grounding Strip	3		09182	00230-00053	1
6-2	Block, Contact	3		09182	00230-20012	1
6-3	Contact, Spring	3		09182	00230-00037	1
6-4	Terminal, Solder Lug	-	902-016-C	78584	0360-0037	-
6-5	Washer, Lock	-		09182	2190-0086	-
6-6	Machine Screw 4-40 x $\frac{1}{4}$ Pan head	-		09182	2200-0139	-
7-1	Block, Shorting Contact	3		09182	00230-20014	1
7-2	NOT ASSIGNED	-	-	-	-	-
7-3	Washer, Lock	-		09182	2190-0086	-
7-4	Contact, Shorting	3		09182	00230-00038	1
7-5	Screw, Machine 4-40 x $\frac{1}{4}$ Binder hd.	-		09182	-	-

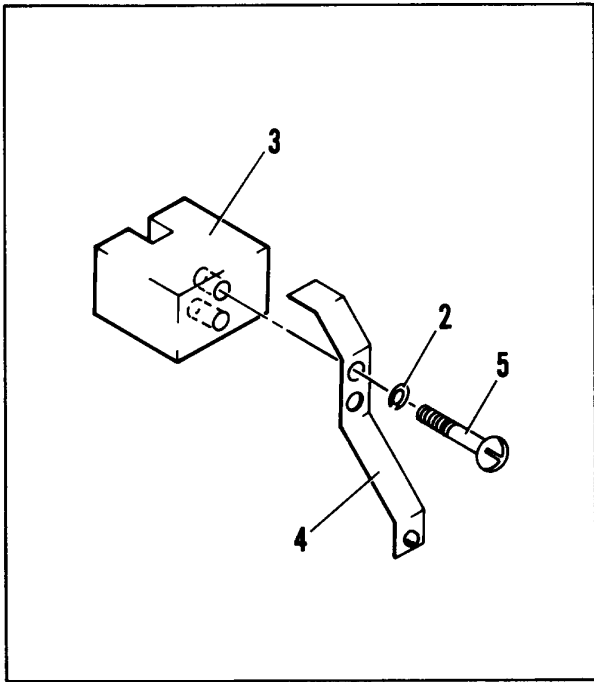

Figure 6-4. Refer to Figure 6-2, #7

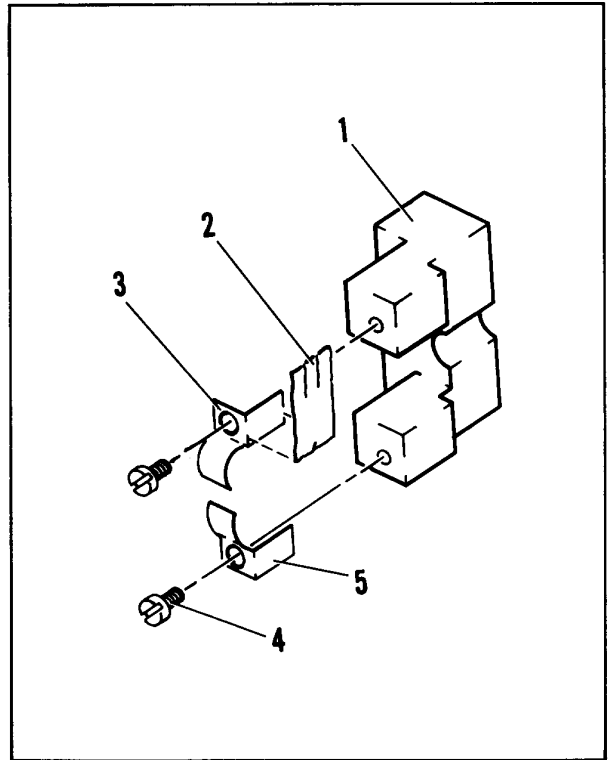

Figure 6-5. Refer to Figure 6-2, #58

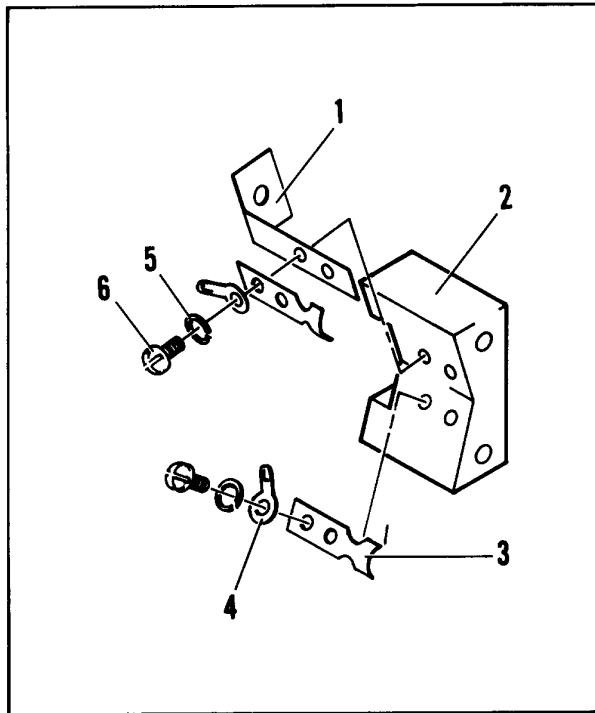

Figure 6-6. Refer to Figure 6-2, #5

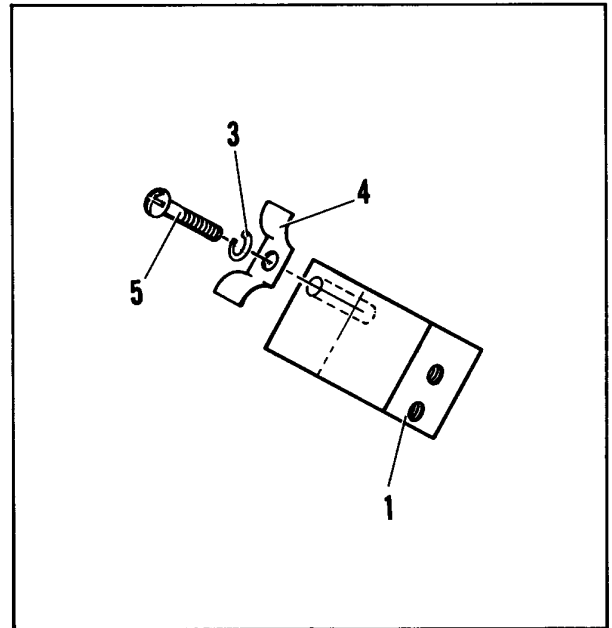

Figure 6-7. Refer to Figure 6-2, #48

SECTION VII CIRCUIT DIAGRAMS

This section contains the circuit diagrams necessary for the operation and maintenance of this unit. Included are:

a. Component Location Diagrams which shows the physical location and reference design-

nator of parts mounted on the printed wiring board.

b. Schematic Diagram, which illustrates the circuitry for the entire unit. Voltages are given adjacent to test points, identified by encircled numbers on the schematic.

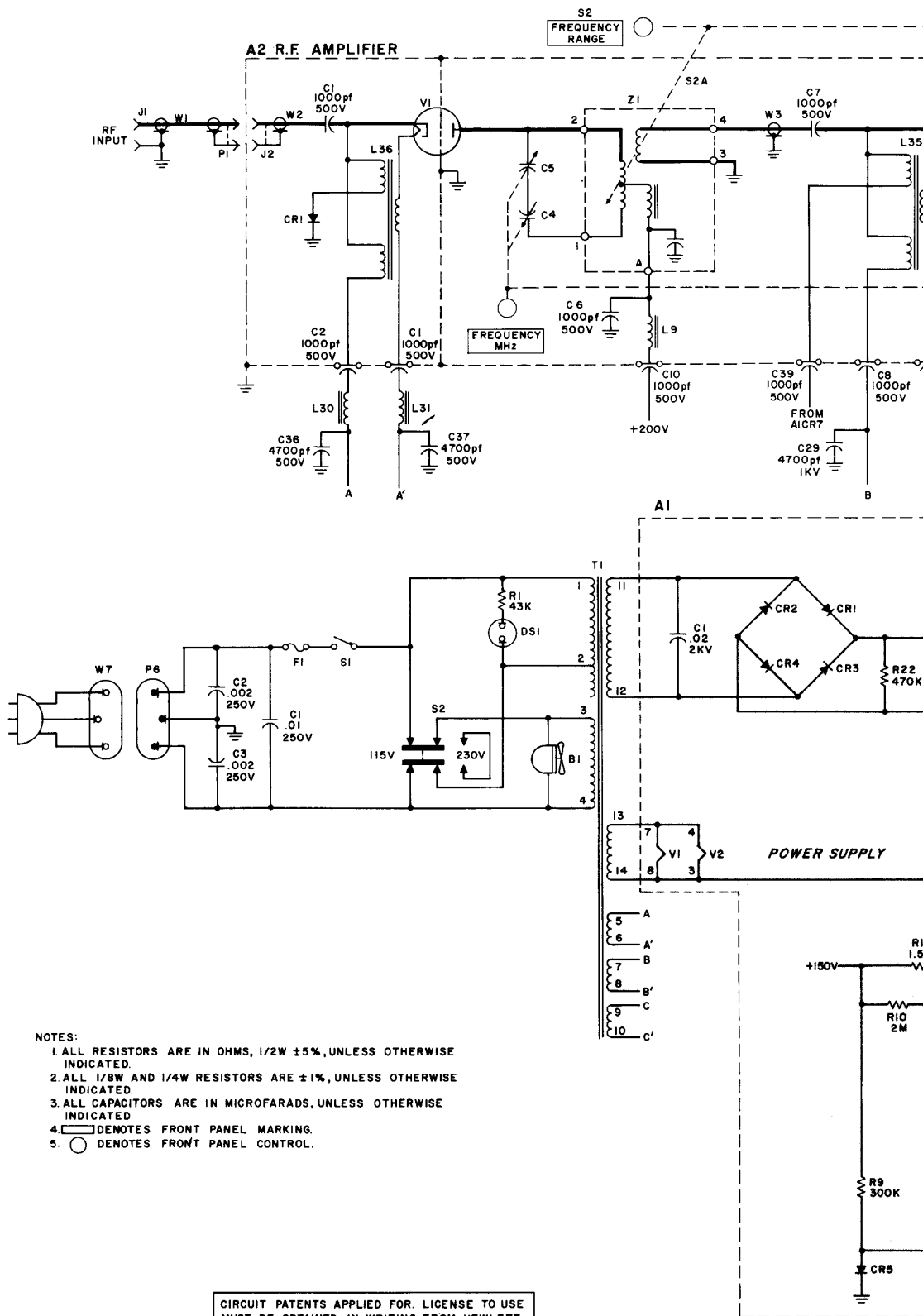

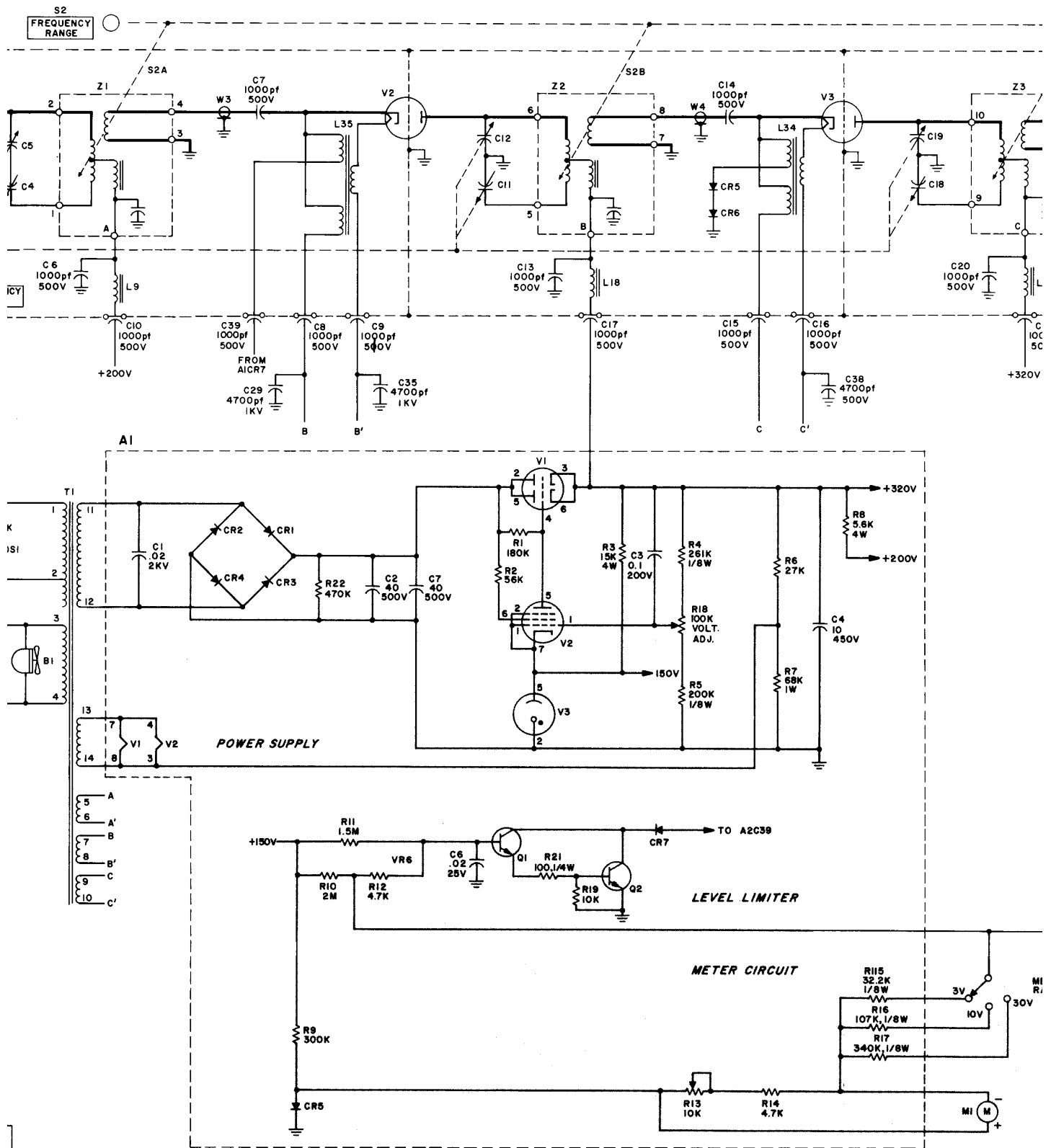

Figure 7-2. Mode

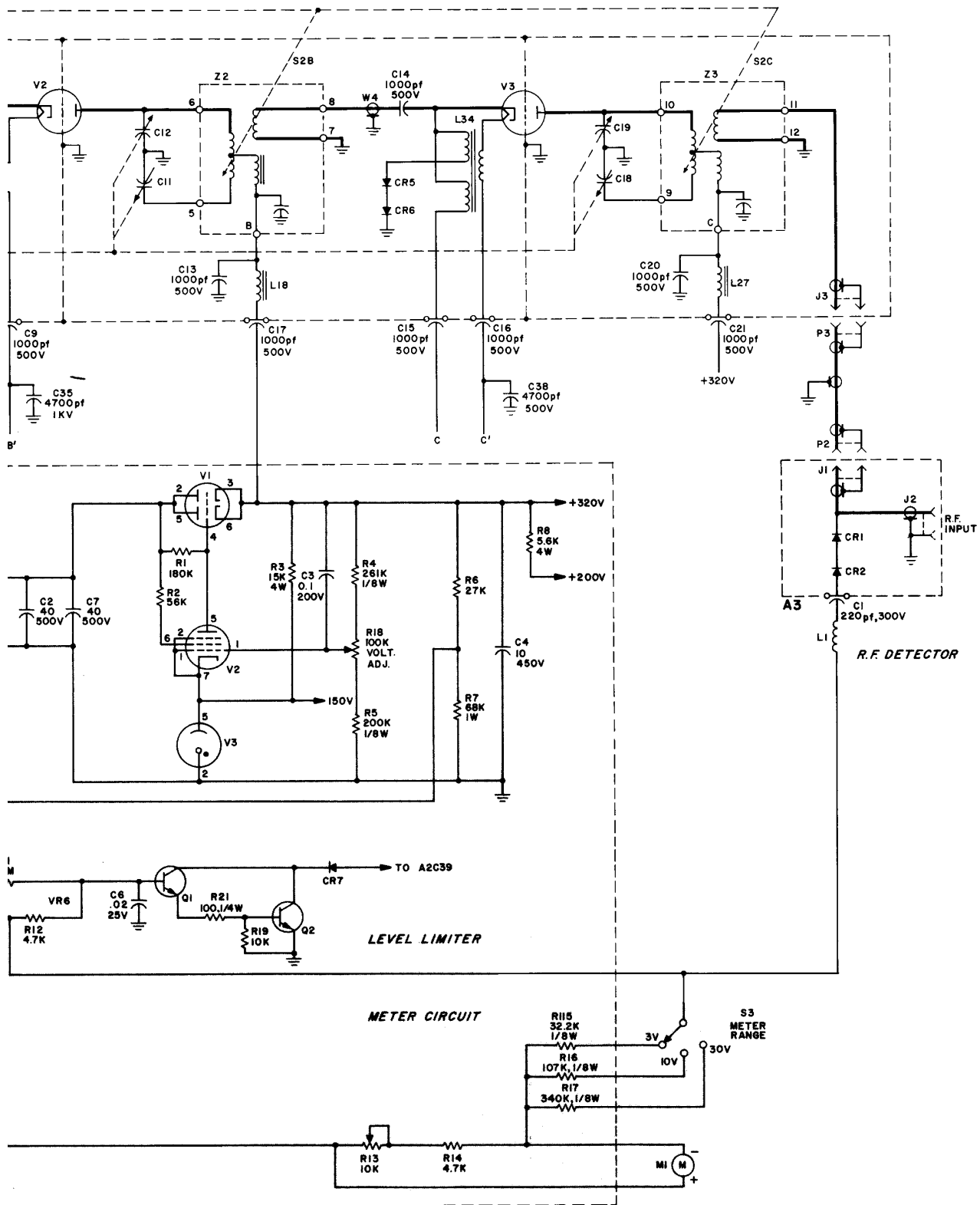

Figure 7-2. Model 230B, Schematic Diagram



MANUAL CHANGES

MODEL: 230B

Manual Serial Prefixed: 935

HP Part No.: 00230-90039

To adapt this manual to instruments with other serial prefixes check for errata below, and make changes shown in tables.

Instrument Serial Prefix	Make Manual Changes
Errata	All
936	1
1026	1,2
1202	1,2,3

Instrument Serial Prefix	Make Manual Changes

Δ New or revised item.

ERRATA

Page 4-2, Paragraph 4-11.

The fourth sentence in the paragraph should read: This is accomplished by making the piston of A2C12 (A2C4 and A2C18) physically shorter than A2C11 (A2C5 and A2C19).

Page 4-2, Paragraph 4-17.

The first sentence should read: The cathode of A1V1 supplies a regulated +320 volts to RF amplifiers A2V2 and A2V3. Resistor R8 drops the +320 volts to +200 volts for RF amplifier A2V1.

Page 5-7, Paragraph 5-42 (step g.)

Change: R125 to R13

Page 7-1, Figure 7-2.

Change notation of RF Input adjacent to A3-J2 to read RF Output.

Figures 5-1, 5-2, and 5-4.

Delete: HP Part No. 8491A for the 10db attenuator. Use instead HP Part No. 0950-0094 10db attenuator. Also reverse the physical positions of the attenuators so that the 10db attenuator is closest to the 50 ohm termination.

CHANGE 1

Page 6-6. Table 6-4.

Change: DS1 description to read: light indicator (white) part number to 1450-0419.

F1(115v) part number to 2110-0303

F1 (230v)part number to 2110-0312

S1 part number to 3101-0003

S2 part number to 3101-1234

AlR15 description to read: 31.6K part number to 0698-3160.

Page 6-12, Item 5-2.

Change: description to read Strap, part number to 00230-00013.

Page 7-1, Figure 7-2. Schematic Diagram (meter circuit).

Change: R115 to read R15 and description to 31.6Kohms.

Δ CHANGE 2.

Page 6-5, Table 6-4.

Change the part number for Frequency Knob to 0370-0038.

Change the part number for Meter Bezel to 4040-0293.

Δ CHANGE 3.

The standard colors for this instrument are now mint gray (for front panel) and olive gray (for all other external surfaces). Option X95 designates use of the former color scheme of light gray and blue gray. Option A85 designates use of a light gray front panel with olive gray used for all other external surfaces. New part numbers are shown below:

DESCRIPTION	HP Part Number		
	Standard	Option A85	Option X95
Front Panel	00230-01017	00230-01004	Refer to Manual Parts List
Cabinet Assembly	00230-61007	00230-61007	
Air Filter	5060-8772	5060-8772	

EUROPE

AUSTRIA
Unilabor GmbH
Wissenschaftliche Instrumente
Rummelhardtgasse 6
P.O. Box 33
Vienna A-1095
Tel: (222) 42 61 81, 43 13 94
Cable: LABORINSTRUMENT
Vienna
Telex: 75 762

BELGIUM
Hewlett-Packard S.A. Benelux
348 Boulevard du Souverain
Brussels 1160
Tel: 72 22 40
Cable: PALOBEN Brussels
Telex: 23 494

DENMARK
Hewlett-Packard A/S
Datavej 36
DK-3460 Birkerød
Tel: (01) 81 66 40
Cable: HEWPACK AS
Telex: 66 40
Hewlett-Packard A/S
Torvet 9
DK-8600 Silkeborg
Tel: (06) 827-840

FINLAND
Hewlett-Packard Oy
Bulevardi 26
P.O. Box 12185
Helsinki 12
Tel: 13-730
Cable: HEWPACKOY-Helsinki
Telex: 12-1563

FRANCE
Hewlett-Packard France
Quartier de Courtaboeuf
Boîte Postale No. 6
91 Orsay
Tel: 1-920 88 01
Cable: HEWPACK Orsay
Telex: 60048

Hewlett-Packard France
4 Quai des Etoiles
69 Lyon 6ème
Tel: 78-42 53 45
Cable: HEWPACK Lyon
Telex: 31617

Hewlett-Packard France
29 rue de la Gara
F-31 Blagnac
Tel: (61) 85 82 29
Telex: 51957

GERMANY
Tel: 41 32 49 FRA
Berliner Strasse 117
5 Nieder-Eschbach/Frankfurt 56
Tel: (0511) 50 10 64
Cable: HEWPACKSA Frankfurt
Hewlett-Packard Vertriebs-GmbH
Lietzenburgerstrasse 30
1 Berlin 30
Tel: (0311) 211 50 16
Telex: 18 34 05

Hewlett-Packard Vertriebs-GmbH
Herrenbergerstrasse 110
703 Böblingen, Württemberg
Tel: 07031-6671
Cable: HEPAAG Böblingen
Telex: 72 65 739

Hewlett-Packard Vertriebs-GmbH
Achenbachstrasse 15
4 Düsseldorf 1
Tel: (0211) 68 52 58/59
Telex: 85 86 533

Hewlett-Packard Vertriebs-GmbH
Wendenstr. 23
2 Hamburg 1
Tel: (0411) 24 05 51/52
Cable: HEWPACKSA Hamburg
Telex: 21 53 32

Hewlett-Packard Vertriebs-GmbH
Reginfriedstrasse 13
8 München 9
Tel: (0811) 69 59 71/75
Cable: RAKAR Athens
Telex: 52 49 85

GREECE
Kostas Karayannis
18, Ermou Street
Athens 125
Tel: 230301.3.5
Cable: RAKAR Athens
Telex: 21 59 62 RKAR GR

IRELAND
Hewlett-Packard Ltd.
224 Bath Road
Slough, Bucks, England
Cable: HEWPKSA Slough
Telex: 84413

ITALY
Hewlett-Packard Italiana S.p.A.
Via Amerigo Vespucci 2
20124 Milano
Tel: (2) 6251 (10 lines)
Cable: HEWPACKIT Milan
Telex: 32046

Hewlett-Packard Italiana S.p.A.
Palazzo Italia
Piazza Marconi 25
00144 Rome - Eur
Tel: 6-591 2544
Cable: HEWPACKIT Rome
Telex: 61514

NETHERLANDS
Hewlett-Packard Benelux, N.V.
Weerdestein 117
P.O. Box 7825
Amsterdam, Z 11
Tel: 020-42 7777
Cable: PALOBEN Amsterdam
Telex: 13 216

NORWAY
Hewlett-Packard Norge A/S
Box 149
Nesveien 13
N-1344 Haslum
Tel: 2-53 83 60
Cable: HEWPACK Oslo
Telex: 16621

PORTUGAL
Teletra
Empresa Technica de
Equipamentos
Electricos, S.a.r.l.
Rua Rodrigo da Fonseca 103
P.O. Box 2531
Lisbon 1
Tel: 68 60 72
Cable: TELETRA Lisbon
Telex: 1598

SPAIN
Enrique Larreta 12
Madrid, 16
Tel: 215 35 43
Cable: TELETAIO Madrid
Altaio Ingenieros SA
Tel: 27249E
Altaio Ingenieros SA
Ganduxer 76
Barcelona 6
Tel: 211-44-66
Cable: TELETAIO BARCELONA

SWEDEN (Jan 71)
Hewlett-Packard Sverige AB
Enighetsvägen 1-3
Fack
S-16120 Bromma 20
Tel: (08) 98 12 50
Cable: MEASUREMENTS
Stockholm
Telex: 10721

Hewlett-Packard Sverige AB
Hagakergatan 9C
S 431 04 Mjölndal 4
Tel: 031 - 27 68 00

SWITZERLAND
Hewlett Packard Schweiz AG
Zürcherstrasse 20
8952 Schlieren
Zürich
Tel: (051) 98 18 21/24
Cable: HPAC CH
Telex: 53933
Hewlett Packard Schweiz A.G.
Rue du Bois-du-Lan 7
1217 Meyrin 2 Geneva
Tel: (022) 41 54 00
Cable: HEWPACKSA Geneva
Telex: 2 24 86

TURKEY
Telekom Engineering Bureau
P.O. Box 376
Karakoy
Istanbul
Tel: (051) 40 40
Cable: TELEMATIOM Istanbul

UNITED KINGDOM
Hewlett-Packard Ltd.
224 Bath Road
Slough, Bucks
Tel: Slough (0753) 33341
Cable: HEWPKIE Slough
Telex: 84413

Hewlett-Packard Ltd.
The Griflions
Stamford New Road
Aitricham, Cheshire
Tel: 061 928-8626
Telex: 668068

YUGOSLAVIA
Belram S.A.
83 avenue des Mimosas
Brussels 1150, Belgium
Tel: 34 33 32, 34 26 19
Cable: BELRAMEL Brussels
Telex: 21790

SOCIALIST COUNTRIES
PLEASE CONTACT:
Correspondence Office for
Eastern Europe
Innstrasse 23/2
Postfach
A1204 Vienna, Austria
Tel: (222) 3366 06/09
Cable: HEWPACK Vienna
Telex: 75923

ALL OTHER EUROPEAN
COUNTRIES CONTACT:
Hewlett-Packard S.A.
Rue du Bois-du-Lan 7
1217 Meyrin 2 Geneva
Switzerland
Tel: (022) 41 54 00
Cable: HEWPACKSA Geneva
Telex: 2.24.86

AFRICA, ASIA, AUSTRALIA

ANGOLA
Teletra Empresa Técnica
de Equipamentos Eléctricos
SAR
Rua de Barbosa Rodrigues
42-1°
Box 6487
Luanda
Cable: TELETRA Luanda

AUSTRALIA
Hewlett-Packard Australia
Pty. Ltd.
22-26 Weir Street
Glen Iris, 3146
Victoria
Tel: 20-1371 (6 lines)
Cable: HEWPARD Melbourne
Telex: 31024

Hewlett-Packard Australia
Pty. Ltd.
61 Alexander Street
Crows Nest 2065
New South Wales
Tel: 43 7866
Cable: HEWPARD Sydney
Telex: 21561

Hewlett-Packard Australia
Pty. Ltd.
97 Churchhill Road
Prospect 5082
South Australia
Tel: 65-2366
Cable: HEWPARD Adelaide

Hewlett Packard Australia
Pty. Ltd.
2nd Floor, Suite 13
Casablanca Buildings
196 Adelaide Terrace
Perth, W.A. 6000
Tel: 21-3330
Cable: HEWPARD Perth

Hewlett-Packard Australia
Pty. Ltd.
10 Woolley Street
P.O. Box 191
Dickson A.C.T. 2602
Tel: 49-8194
Cable: HEWPARD Canberra ACT

CEYLON
United Electricals Ltd.
P.O. Box 681
Yahala Building
Staples Street
Colombo 2
Tel: 5496
Cable: HOTPOINT Colombo

CYPRUS
Kypronics
19 Gregorios & Xenopoulos Road
P.O. Box 1152
Nicosia
Tel: 6282-75628
Cable: HE-1-NAM1

ETHIOPIA
African Salespower & Agency
Private Ltd., Co.
P.O. Box 718
58/59 Cunningham St.
Addis Ababa
Tel: 12285
Cable: ASACO Addisababa

HONG KONG
Schmidt & Co. (Hong Kong) Ltd.
P.O. Box 297
1511, Prince's Building 15th Floor
10, Chater Road
Hong Kong
Tel: 240168, 232735
Cable: SCHMIDTCO Hong Kong

INDIA
Blue Star Ltd.
Kasturi Buildings
Jamshedji Tata Rd.
Bombay 20BR, India
Tel: 29 50 21
Telex: 2396
Cable: BLUEFROST

Blue Star Ltd.
Band Box House
Prabhadevi
Bombay 25DD, India
Tel: 45 73 01
Telex: 2396
Cable: BLUESTAR

Blue Star Ltd.
14/40 Civil Lines
Kanpur, India
Tel: 6 88 82
Cable: BLUESTAR

Blue Star, Ltd.
7 Mare Street
P.O. Box 506
Calcutta 1, India
Tel: 23-0131
Telex: 655
Cable: BLUESTAR

Blue Star Ltd.
Blue Star House,
34 Ring Road
Lajpat Nagar
New Delhi 24, India
Tel: 62 32 76
Telex: 463
Cable: BLUESTAR

Blue Star Ltd.
17-C Ulsoor Road
Bangalore 8
Tel: 2 39 55
Cable: BLUEFROST

Blue Star, Ltd.
23/24 Second Line Beach
Madras 1, India
Tel: 2 39 55
Telex: 379
Cable: BLUESTAR

Blue Star, Ltd.
1B Kaiser Bungalow
Dindri Road
Jamsheer, India
Tel: 38 04
Cable: BLUESTAR

INDONESIA
Bah Bolon Trading Coy. N.V.
Djaloh Merdeka 29
Bandung
Tel: 4915 51560
Cable: ILMU
Telex: 809

IRAN
Telecom, Ltd.
P.O. Box 1812
240 Kh. Saba Shomali
Teheran
Tel: 43850, 48111
Cable: BASCOM Teheran

ISRAEL
Electronics & Engineering
Div. of Motorola Israel Ltd.
17 Aminadav Street
Tel-Aviv
Tel: 36941 (3 lines)
Cable: BASTEL Tel-Aviv
Telex: Bastei Tv 033-569

JAPAN
Yokogawa-Hewlett-Packard Ltd.
Ohashi Building
59 Yoyogi 1-chrome
Shibuya-ku, Tokyo
Tel: 03-370-2281/7
Telex: 232-2024YHP
Cable: YHPMARKET TOK 23-724

Yokogawa-Hewlett-Packard Ltd.
Nisei Ibaragi Bldg.
2-2-8 Kasuga
Ibaragi-Shi
Osaka
Tel: 23-1641

Yokogawa-Hewlett-Packard Ltd.
Ho Building
No. 59, Kotori-cho
Nakamura-ku, Nagoya City
Tel: 551-0215

Yokogawa-Hewlett-Packard Ltd.
Nitto Bldg.
2300 Shinohara-cho,
Kokubo-ku
Yokohama 222
Tel: (405) 432-1504/5

KENYA
R. J. Tilbury Ltd.
P.O. Box 2754
Suite 517/518
Hotel Ambassador
Nairobi
Tel: 25670, 68206, 58196
Cable: ARJAYTEE Nairobi

LEBANON
Constantin E. Macridis
Clemenceau Street
P.O. Box 7213
Beirut
Tel: 220846
Cable: ELECTRONUCLEAR Beirut

MALAYSIA
MECOMB Malaysia Ltd.
2 Lorong 13/6A
Section 13
Petaling Jaya, Selangor
Cable: MECOMB Kuala Lumpur

MOZAMBIQUE
A. H. Goncalves, LDA.
4.1 Apt. 14 Av. D. Luis
P.O. Box 107
Loarens Marques
Cable: NEGON

NEW ZEALAND
Hewlett-Packard (N.Z.) Ltd.
32-34 Kant Terrace
P.O. Box 9443
Wellington, N.Z.
Tel: 56-559
Cable: HEWPACK Wellington

Hewlett Packard (N.Z.) Ltd.
Box 51092
Pukuranga
Tel: 573-733

PAKISTAN (EAST)
Musko & Company, Ltd.
Zirat Chambers
31, Jinnah Avenue
Dacca
Tel: 280058
Cable: NEWDEAL Dacca

PAKISTAN (WEST)
Musko & Company, Ltd.
Osman Chambers
Victoria Road
Karachi 3
Tel: 511027, 512927
Cable: COOPERATOR Karachi

PHILIPPINES
Electromex Inc.
Makati Commercial Center
2129 Pasong Tamo
Makati, Rizal D 708
P.O. Box 1028
Manila
Tel: 89-85-01
Cable: ELEMEX Manila

SINGAPORE
Mechanical and Commission
Engineering Company Ltd.
9, Jalan Kilang
Red Hill Industrial Estate
Singapore, 3
Tel: 542361-3
Cable: MECOMB Singapore

SOUTH AFRICA
Hewlett Packard South Africa
(Pty.), Ltd.
P.O. Box 31716
Braamfontein Transvaal
Minerston
30 De Beer Street
Johannesburg
Tel: 725-2080, 725-2030
Cable: 0226 JH

Hewlett Packard South Africa
(Pty.), Ltd.
Breastle House
Bree Street
Cape Town
Tel: 3-6019, 3-6545
Cable: HEWPACK Cape Town
Telex: 5-0006

Hewlett Packard South Africa
(Pty.), Ltd.
30B Glenwood Centre
Corner Hunt & Moore Roads
P.O. Box 99
Overport, Natal
Tel: 347536

TAIWAN REP. OF CHINA
Hewlett Packard Taiwan
39 Chung Shiao West
Sec. 1
Overseas Insurance
Cable Bldg. 7th Floor
Taipei
Tel: 579-605, 579-610, 579-613
Telex: c/o Bankamerica TP 339
Cable: HEWPACK Taipei

THAILAND
The International
Engineering Co., Ltd.
P.O. Box 39
614 Sukhumvit Road
Bangkok
Tel: 910722 (7 lines)
Cable: GYSOM
TLX INTENCO BK-226 Bangkok

VIETNAM
Peninsular Trading Inc.
P.O. Box H-3
216 Hien-Vuong
Saigon
Tel: 20.805
Cable: PENINSULA Saigon

ZAMBIA
R. J. Tilbury (Zambia) Ltd.
P.O. Box 2792
Lusaka
Zambia, Central Africa

MEDITERRANEAN AND
MIDDLE EAST COUNTRIES
NOT SHOWN PLEASE
CONTACT:
Hewlett-Packard Correspondence
Office
Piazza Marconi 25
I-00144 Rome-Eur, Italy
Tel: (6) 59 40 29
Cable: HEWPACKIT Rome
Telex: 61514

OTHER AREAS NOT
LISTED, CONTACT:
Hewlett-Packard
INTERCONTINENTAL
3200 Hillview Ave.
Palo Alto, California 94304
Tel: (415) 326-7000
(Feb. 71) 493-1501
TWX: 910-373-1267
Cable: HEWPACK Palo Alto
Telex: 034-8461

HEWLETT • PACKARD SALES AND SERVICE

SALES & SERVICE OFFICES

UNITED STATES

ALABAMA

P.O. Box 4207
2003 Byrd Spring Road S.W.
Huntsville 35802
Tel: (205) 861-4591
TWX: 810-726-2204

ARIZONA

2336 E. Magnolia St.
Phoenix 85034
Tel: (602) 252-5061
TWX: 910-951-1330

5737 East Broadway
Tucson 85716
Tel: (602) 298-2313
TWX: 910-952-1182

CALIFORNIA

1430 East Orangehorpe Ave.
Fullerton 92631
Tel: (714) 870-1000

3939 Lankershim Boulevard
North Hollywood 91604
Tel: (213) 877-1282
TWX: 910-499-2170

1101 Embarcadero Road
Palo Alto 94303
Tel: (415) 327-6500
TWX: 910-373-1280

2220 Watt Ave.
Sacramento 95825
Tel: (916) 482-1463
TWX: 910-367-2092

9606 Aero Drive
San Diego 92123
Tel: (714) 279-3200
TWX: 910-335-2000

7965 East Prentice
Englewood 80110
Tel: (303) 771-3455
TWX: 910-935-0705

CONNECTICUT

508 Tolland Street
East Hartford 06108
Tel: (203) 289-9394
TWX: 710-425-3416

111 East Avenue
Norwalk 06851
Tel: (203) 853-1251
TWX: 710-468-3750

FLORIDA

P.O. Box 24210
2806 W. Oakland Park Blvd.
Ft. Lauderdale 33307
Tel: (305) 731-2020
TWX: 510-955-4099

P.O. Box 20007
Herndon Station 32814
621 Commonwealth Avenue
Orlando
Tel: (305) 841-3970
TWX: 810-850-0113

5500 Howard Street
Skokie 60076
Tel: (312) 677-0400
TWX: 910-223-3613

3839 Meadows Drive
Indianapolis 46205
Tel: (317) 546-4891
TWX: 810-341-3263

2812 South Brentwood Blvd.
St. Louis 63144
Tel: (314) 962-5000
TWX: 910-760-1670

11131 Colorado Ave.
Kansas City 64137
Tel: (816) 763-8000
TWX: 910-771-2087

2459 University Avenue
St. Paul 55114
Tel: (612) 845-9461
TWX: 910-563-3734

511 Bradford Ct.
St. James
Tel: (204) 796-7581
TWX: 610-671-3531

11131 Colorado Ave.
Kansas City 64137
Tel: (816) 763-8000
TWX: 910-771-2087

2459 University Avenue
St. Paul 55114
Tel: (612) 845-9461
TWX: 910-563-3734

511 Bradford Ct.
St. James
Tel: (204) 796-7581
TWX: 610-671-3531

11131 Colorado Ave.
Kansas City 64137
Tel: (816) 763-8000
TWX: 910-771-2087

2459 University Avenue
St. Paul 55114
Tel: (612) 845-9461
TWX: 910-563-3734

511 Bradford Ct.
St. James
Tel: (204) 796-7581
TWX: 610-671-3531

11131 Colorado Ave.
Kansas City 64137
Tel: (816) 763-8000
TWX: 910-771-2087

2459 University Avenue
St. Paul 55114
Tel: (612) 845-9461
TWX: 910-563-3734

511 Bradford Ct.
St. James
Tel: (204) 796-7581
TWX: 610-671-3531

11131 Colorado Ave.
Kansas City 64137
Tel: (816) 763-8000
TWX: 910-771-2087

2459 University Avenue
St. Paul 55114
Tel: (612) 845-9461
TWX: 910-563-3734

511 Bradford Ct.
St. James
Tel: (204) 796-7581
TWX: 610-671-3531

11131 Colorado Ave.
Kansas City 64137
Tel: (816) 763-8000
TWX: 910-771-2087

2459 University Avenue
St. Paul 55114
Tel: (612) 845-9461
TWX: 910-563-3734

511 Bradford Ct.
St. James
Tel: (204) 796-7581
TWX: 610-671-3531

11131 Colorado Ave.
Kansas City 64137
Tel: (816) 763-8000
TWX: 910-771-2087

2459 University Avenue
St. Paul 55114
Tel: (612) 845-9461
TWX: 910-563-3734

511 Bradford Ct.
St. James
Tel: (204) 796-7581
TWX: 610-671-3531

11131 Colorado Ave.
Kansas City 64137
Tel: (816) 763-8000
TWX: 910-771-2087

2459 University Avenue
St. Paul 55114
Tel: (612) 845-9461
TWX: 910-563-3734

511 Bradford Ct.
St. James
Tel: (204) 796-7581
TWX: 610-671-3531

LOUISIANA

P.O. Box 856
1942 Williams Boulevard
Kenner 70062
Tel: (504) 721-6201
TWX: 810-955-5524

MARYLAND

6707 Whitestone Road
Baltimore 21207
Tel: (301) 944-5400
TWX: 710-862-0850

P.O. Box 1648
2 Choke Cherry Road
Rockville 20850
Tel: (301) 948-6370
TWX: 710-828-9684

MASSACHUSETTS

32 Hartwell Ave.
Lexington 02173
Tel: (617) 861-8960
TWX: 710-326-6904

24315 Northwestern Highway
Southfield 48075
Tel: (313) 353-9100
TWX: 810-224-4882

2459 University Avenue
St. Paul 55114
Tel: (612) 845-9461
TWX: 910-563-3734

511 Bradford Ct.
St. James
Tel: (204) 796-7581
TWX: 610-671-3531

11131 Colorado Ave.
Kansas City 64137
Tel: (816) 763-8000
TWX: 910-771-2087

2459 University Avenue
St. Paul 55114
Tel: (612) 845-9461
TWX: 910-563-3734

511 Bradford Ct.
St. James
Tel: (204) 796-7581
TWX: 610-671-3531

11131 Colorado Ave.
Kansas City 64137
Tel: (816) 763-8000
TWX: 910-771-2087

2459 University Avenue
St. Paul 55114
Tel: (612) 845-9461
TWX: 910-563-3734

511 Bradford Ct.
St. James
Tel: (204) 796-7581
TWX: 610-671-3531

11131 Colorado Ave.
Kansas City 64137
Tel: (816) 763-8000
TWX: 910-771-2087

2459 University Avenue
St. Paul 55114
Tel: (612) 845-9461
TWX: 910-563-3734

511 Bradford Ct.
St. James
Tel: (204) 796-7581
TWX: 610-671-3531

11131 Colorado Ave.
Kansas City 64137
Tel: (816) 763-8000
TWX: 910-771-2087

2459 University Avenue
St. Paul 55114
Tel: (612) 845-9461
TWX: 910-563-3734

511 Bradford Ct.
St. James
Tel: (204) 796-7581
TWX: 610-671-3531

11131 Colorado Ave.
Kansas City 64137
Tel: (816) 763-8000
TWX: 910-771-2087

2459 University Avenue
St. Paul 55114
Tel: (612) 845-9461
TWX: 910-563-3734

511 Bradford Ct.
St. James
Tel: (204) 796-7581
TWX: 610-671-3531

11131 Colorado Ave.
Kansas City 64137
Tel: (816) 763-8000
TWX: 910-771-2087

2459 University Avenue
St. Paul 55114
Tel: (612) 845-9461
TWX: 910-563-3734

511 Bradford Ct.
St. James
Tel: (204) 796-7581
TWX: 610-671-3531

11131 Colorado Ave.
Kansas City 64137
Tel: (816) 763-8000
TWX: 910-771-2087

2459 University Avenue
St. Paul 55114
Tel: (612) 845-9461
TWX: 910-563-3734

511 Bradford Ct.
St. James
Tel: (204) 796-7581
TWX: 610-671-3531

11131 Colorado Ave.
Kansas City 64137
Tel: (816) 763-8000
TWX: 910-771-2087

2459 University Avenue
St. Paul 55114
Tel: (612) 845-9461
TWX: 910-563-3734

511 Bradford Ct.
St. James
Tel: (204) 796-7581
TWX: 610-671-3531

1060 N. Kings Highway
Cherry Hill 08034
Tel: (609) 667-4000
TWX: 710-892-4945

NEW MEXICO

P.O. Box 8366
Station C
6501 Lomas Boulevard N.E.
Albuquerque 87108
Tel: (505) 265-3713
TWX: 910-989-1665

156 Wyatt Drive
Las Cruces 88001
Tel: (505) 526-2485
TWX: 910-983-0550

NEW YORK

1702 Central Avenue
Albany 12205
Tel: (518) 869-8462
TWX: 710-441-8270

1219 Campville Road
Endicott 13760
Tel: (607) 754-0050
TWX: 510-252-0890

82 Washington Street
Poughkeepsie 12601
Tel: (914) 454-7330
TWX: 510-248-0012

35 Saginaw Drive
Rochester 14623
Tel: (716) 473-9500
TWX: 510-253-5981

1025 Northern Boulevard
Roslyn, Long Island 11576
Tel: (516) 869-8400
TWX: 510-223-0811

5858 East Molloy Road
Syracuse 13211
Tel: (315) 454-2466
TWX: 710-541-0482

P.O. Box 5188
1923 North Main Street
High Point 27282
Tel: (919) 885-8101
TWX: 910-926-1516

1025 Northern Boulevard
Roslyn, Long Island 11576
Tel: (516) 869-8400
TWX: 510-223-0811

5858 East Molloy Road
Syracuse 13211
Tel: (315) 454-2466
TWX: 710-541-0482

P.O. Box 5188
1923 North Main Street
High Point 27282
Tel: (919) 885-8101
TWX: 910-926-1516

1025 Northern Boulevard
Roslyn, Long Island 11576
Tel: (516) 869-8400
TWX: 510-223-0811

5858 East Molloy Road
Syracuse 13211
Tel: (315) 454-2466
TWX: 710-541-0482

P.O. Box 5188
1923 North Main Street
High Point 27282
Tel: (919) 885-8101
TWX: 910-926-1516

1025 Northern Boulevard
Roslyn, Long Island 11576
Tel: (516) 869-8400
TWX: 510-223-0811

5858 East Molloy Road
Syracuse 13211
Tel: (315) 454-2466
TWX: 710-541-0482

P.O. Box 5188
1923 North Main Street
High Point 27282
Tel: (919) 885-8101
TWX: 910-926-1516

1025 Northern Boulevard
Roslyn, Long Island 11576
Tel: (516) 869-8400
TWX: 510-223-0811

5858 East Molloy Road
Syracuse 13211
Tel: (315) 454-2466
TWX: 710-541-0482

P.O. Box 5188
1923 North Main Street
High Point 27282
Tel: (919) 885-8101
TWX: 910-926-1516

1025 Northern Boulevard
Roslyn, Long Island 11576
Tel: (516) 869-8400
TWX: 510-223-0811

5858 East Molloy Road
Syracuse 13211
Tel: (315) 454-2466
TWX: 710-541-0482

P.O. Box 5188
1923 North Main Street
High Point 27282
Tel: (919) 885-8101
TWX: 910-926-1516

1025 Northern Boulevard
Roslyn, Long Island 11576
Tel: (516) 869-8400
TWX: 510-223-0811

5858 East Molloy Road
Syracuse 13211
Tel: (315) 454-2466
TWX: 710-541-0482

P.O. Box 5188
1923 North Main Street
High Point 27282
Tel: (919) 885-8101
TWX: 910-926-1516

1025 Northern Boulevard
Roslyn, Long Island 11576
Tel: (516) 869-8400
TWX: 510-223-0811

5858 East Molloy Road
Syracuse 13211
Tel: (315) 454-2466
TWX: 710-541-0482

P.O. Box 5188
1923 North Main Street
High Point 27282
Tel: (919) 885-8101
TWX: 910-926-1516

OHIO

25575 Center Ridge Road
Cleveland 44145
Tel: (216) 805-0300
TWX: 810-427-9129

3460 South Dixie Drive
Dayton 45459
Tel: (513) 298-0351
TWX: 810-459-1925

1120 Morse Road
Columbus 43229
Tel: (614) 846-1300

OKLAHOMA

2919 United Founders Boulevard
Oklahoma City 73112
Tel: (405) 848-2801
TWX: 910-830-6862

OREGON

Westhills Mall, Suite 158
4475 S.W. Scholls Ferry Road
Portland 97225
Tel: (503) 292-9171
TWX: 910-464-6103

PENNSYLVANIA

2500 Moss Side Boulevard
Monroeville 15146
Tel: (412) 271-0724
TWX: 710-797-3650

1021 8th Avenue
King of Prussia Industrial Park
King of Prussia 19406
Tel: (215) 265-7000
TWX: 910-660-2670

RHODE ISLAND

873 Waterman Ave.
East Providence 02914
Tel: (401) 434-5535
TWX: 710-381-7573

TEXAS

P.O. Box 1270
201 E. Arapaho Rd.
Richardson 75080
Tel: (214) 231-6101
TWX: 910-867-4723

50 Galaxy Blvd.
Rexdale
Tel: (416) 677-9611
TWX: 610-492-4246

1025 Northern Boulevard
Roslyn, Long Island 11576
Tel: (516) 869-8400
TWX: 510-223-0811

5858 East Molloy Road
Syracuse 13211
Tel: (315) 454-2466
TWX: 710-541-0482

P.O. Box 5188
1923 North Main Street
High Point 27282
Tel: (919) 885-8101
TWX: 910-926-1516

1025 Northern Boulevard
Roslyn, Long Island 11576
Tel: (516) 869-8400
TWX: 510-223-0811

5858 East Molloy Road
Syracuse 13211
Tel: (315) 454-2466
TWX: 710-541-0482

P.O. Box 5188
1923 North Main Street
High Point 27282
Tel: (919) 885-8101
TWX: 910-926-1516

1025 Northern Boulevard
Roslyn, Long Island 11576
Tel: (516) 869-8400
TWX: 510-223-0811

5858 East Molloy Road
Syracuse 13211
Tel: (315) 454-2466
TWX: 710-541-0482

P.O. Box 5188
1923 North Main Street
High Point 27282
Tel: (919) 885-8101
TWX: 910-926-1516

1025 Northern Boulevard
Roslyn, Long Island 11576
Tel: (516) 869-8400
TWX: 510-223-0811

5858 East Molloy Road
Syracuse 13211
Tel: (315) 454-2466
TWX: 710-541-0482

P.O. Box 5188
1923 North Main Street
High Point 27282
Tel: (919) 885-8101
TWX: 910-926-1516

1025 Northern Boulevard
Roslyn, Long Island 11576
Tel: (516) 869-8400
TWX: 510-223-0811

5858 East Molloy Road
Syracuse 13211
Tel: (315) 454-2466