

## Errata

**Title & Document Type:** 4274A Service Manual

**Manual Part Number:** 04274-90012

**Revision Date:** September 1980

---

### HP References in this Manual

This manual may contain references to HP or Hewlett-Packard. Please note that Hewlett-Packard's former test and measurement, semiconductor products and chemical analysis businesses are now part of Agilent Technologies. We have made no changes to this manual copy. The HP XXXX referred to in this document is now the Agilent XXXX. For example, model number HP8648A is now model number Agilent 8648A.

### About this Manual

We've added this manual to the Agilent website in an effort to help you support your product. This manual provides the best information we could find. It may be incomplete or contain dated information, and the scan quality may not be ideal. If we find a better copy in the future, we will add it to the Agilent website.

### Support for Your Product

Agilent no longer sells or supports this product. You will find any other available product information on the Agilent Test & Measurement website:

[www.tm.agilent.com](http://www.tm.agilent.com)

Search for the model number of this product, and the resulting product page will guide you to any available information. Our service centers may be able to perform calibration if no repair parts are needed, but no other support from Agilent is available.

4274A-12  
**S E R V I C E   N O T E**

Supersedes:  
 None

HP MODEL 4274A MULTI-FREQUENCY LCR METER

Serial Numbers: See Table 1.

IMPROVEMENT FOR MEMORY BACKUP BATTERY *(opt 003)*

**OBJECTIVE:**

This service note describes a component change on the A9 MPU. This modification applies to instruments equipped with option 003 and with the serial numbers listed in Table 1. The modification should be handled on a Warranty Always basis.

The A9 board without Opt. 003 can be applied with the modification. But, it doesn't need to make any modification on such board. So we should make it clear that the modification should be applied only to the instruments with Opt. 003.

**SYMPTOM AND CAUSE:**

The characteristics of the Schottky diodes used for CR3 and CR4 in the level detector circuit on the A9 MPU board gradually deteriorate. This causes increased reverse bias current which significantly shortens the life of the memory back-up battery.

**IMPLEMENTATION:**

To prolong battery life, the Schottky diodes (1901-0518) should be replaced with general purpose diodes.

The part number of the recommended replacement diode is:

hp P/N: 1901-0025

TW/kh/wa

9/80-33

For more information, call your local HP Sales Office or East (201) 265-5000 - Midwest (312) 677-0400 - South (404) 436-6181 - West (213) 877-7282. Or, write: Hewlett-Packard, 1501 Page Mill Road, Palo Alto, California 94304. In Europe, 1217 Meyrin-Geneva. In Far East, Hachioji, Tokyo.

**MASTER COPY**



Table 1. Applicable Instruments.

Serial Numbers
1838J00101
00106
00108
00110
00111
00112
00113
00114
00115
00116
00120

00121

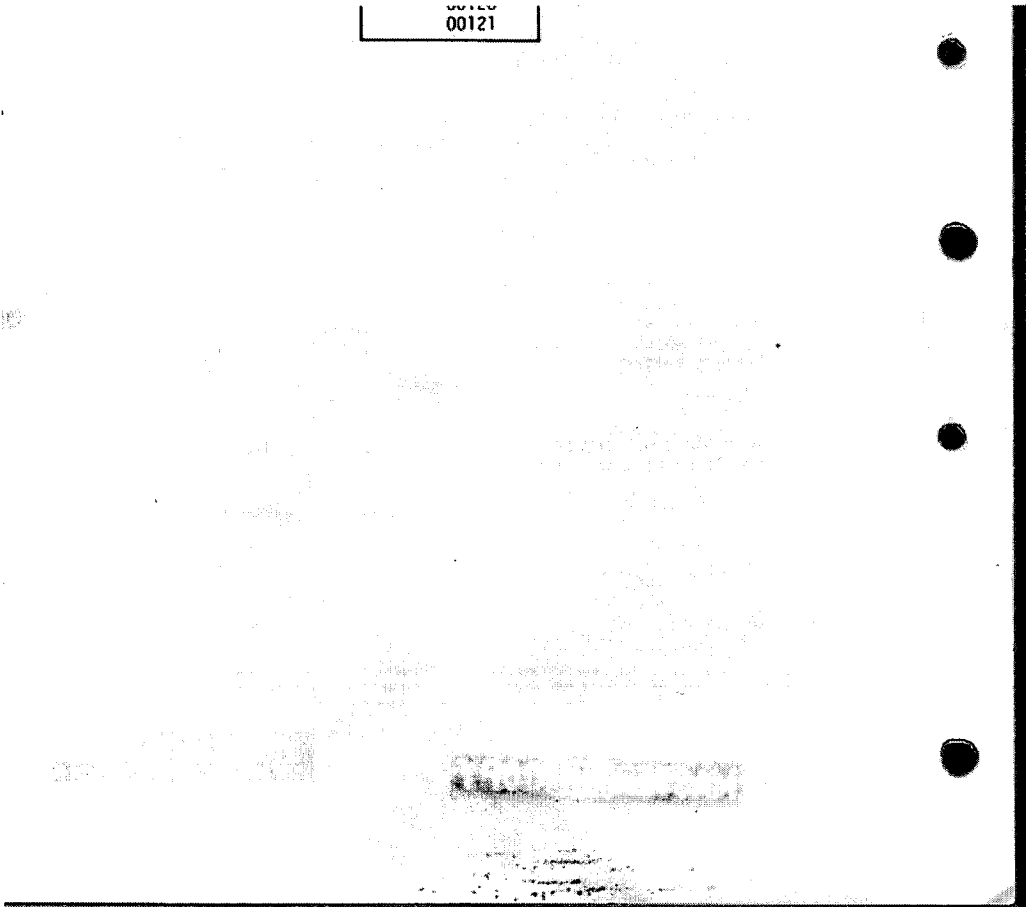

# SERVICE MANUAL

OTS LIBRARY

## 4274A

# MULTI-FREQUENCY LCR METER

OTS LIBRARY



2400001111

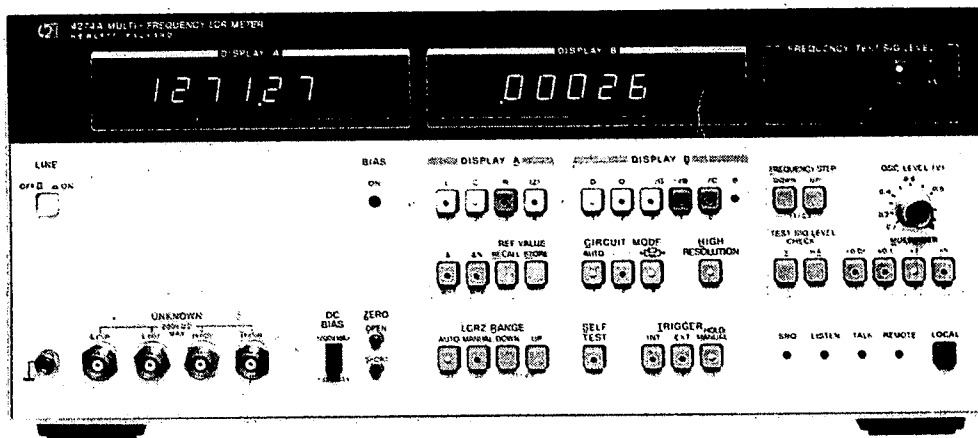

## **CERTIFICATION**

*The Hewlett-Packard Company certifies that this instrument was thoroughly tested and inspected and found to meet its published specifications when it was shipped from the factory. The Hewlett-Packard Company further certifies that its calibration measurements are traceable to the U.S. National Bureau of Standards to the extent allowed by the Bureau's calibration facility.*

## **WARRANTY AND ASSISTANCE**

All Hewlett-Packard products are warranted against defects in materials and workmanship. This warranty applies for one year from the date of delivery, or, in the case of certain major components listed in the operating manual, for the specified period. We will repair or replace products which prove to be defective during the warranty period provided they are returned to Hewlett-Packard. No other warranty is expressed or implied. We are not liable for consequential damages.

Service contracts or customer assistance agreements are available for Hewlett-Packard products that require maintenance and repair on-site.

For any assistance, contact your nearest Hewlett-Packard Sales and Service Office. Addresses are provided at the back of this manual.

PL=34 aads  
Bryan Sapp



HEWLETT  
PACKARD

SERVICE MANUAL

MODEL 4274A

MULTI-FREQUENCY LCR METER

(Including Options 001, 002, 003, 004 and 101)

↑  
Battery on A9 Board  
See parts list.

SERIAL NUMBERS

This manual applies directly to instruments with  
serial numbers prefixed 1850J and above.

COPYRIGHT: YOKOGAWA-HEWLETT-PACKARD, LTD., 1979  
9-1, TAKAKURA-CHO, HACHIOJI-SHI, TOKYO, JAPAN

Manual Part No. 04274-90012  
Microfiche Part No. 04274-90062

Printed: SEP. 1980

## TABLE OF CONTENTS

Section	Title	Page	Section	Title	Page
IV	PERFORMANCE TESTS .....	4-1	V	5-29. A3 Test Signal Level Monitor Adjustment .....	5-17
	4-1. Introduction .....	4-1		5-30. A1 Range Resistor and A4 Buffer Amp Tracking Adjustment .....	5-19
	4-3. Equipment Required .....	4-1		5-31. A1 Range Resistor Phase Adjustment .....	5-21
	4-5. Test Record .....	4-1		5-32. A21 Internal DC Bias Supply Adjustment (0 to $\pm 35V$ ) ...	5-23
	4-7. Calibration Cycle .....	4-1		5-33. A23 Internal DC Bias Supply Adjustment (0 to $\pm 100V$ ) ..	5-24
	Accuracy Test Considerations	4-2			
	Accuracy Test Standards .....	4-4			
	4-9. Test Frequency Accuracy Test	4-6			
	4-11. Test Signal Level (Variable Range Test) .....	4-7	VI	REPLACEABLE PARTS .....	6-1
	4-13. Self-Operating Test .....	4-8		6-1. Introduction .....	6-1
	4-15. Capacitance Accuracy Test ..	4-11		6-3. Abbreviations .....	6-1
	4-17. Resistance Accuracy Test ...	4-14		6-5. Replaceable Parts List .....	6-1
	4-19. Inductance Accuracy Test (Confirmation Test) .....	4-16		6-7. Ordering Information .....	6-2
	4-21. Frequency-phase Accuracy Test .....	4-18		6-10. Spare Parts Kit .....	6-2
	4-23. Int DC Bias Supply Test (Option 001) .	4-20		6-12. Direct Mail Order System ...	6-2
	4-25. Int DC Bias Supply Test (Option 002) .	4-21	VII	MANUAL CHANGES .....	7-1
	4-27. HP-IB Interface Test (Option 101) .....	4-23		7-1. Introduction .....	7-1
				7-3. Manual Changes .....	7-1
V	ADJUSTMENT .....	5-1	VIII	SERVICE .....	8-1
	5-1. Introduction .....	5-1		8-1. Introduction .....	8-1
	5-3. Safety Requirements .....	5-1		8-3. Theory of Operation .....	8-1
	5-7. Equipment Required .....	5-1		8-5. Troubleshooting .....	8-1
	5-9. Factory Selected Components .	5-1		8-7. Recommended Test Equipment ..	8-1
	5-12. Adjustment Relationships ....	5-1		8-9. Repair .....	8-1
	5-14. Adjustment Locations .....	5-1		8-11. Basic Theory .....	8-2
	5-16. Initial Operating Procedure .	5-4		8-23. Block Diagram Discussion ...	8-12
	5-18. A11 Power Supply Voltage Adjustment.....	5-5		8-35. Timing Diagram Discussion ..	8-16
	5-19. A5 ADC DC Reference Adjustment .....	5-6		8-37. Troubleshooting .....	8-19
	5-20. A4 Process Amplifier DC Offset Adjustment .....	5-6		8-38. How to Use Troubleshooting Flow .....	8-19
	5-21. A6 Oscillator Adjustment ....	5-8		8-40. Analog Section Troubleshooting .....	8-20
	5-22. A3 Power Amplifier Adjustment	5-9		8-41. Digital Section Troubleshooting .....	8-20
	5-23. A2 90° Phase Adjustment ....	5-10		8-42. Initial Self Diagnostic Test	8-20
	5-24. A2 Modulator Zero Offset Preadjustment .....	5-11		8-43. Built-in Self Test .....	8-20
	5-25. A1 Buffer Amplifier Adjustment .....	5-12		8-44. Disassembly of Key and Display Board .....	8-26
	5-26. A2 Modulator Zero Offset Adjustment .....	5-13		8-45. Product Safety Checks .....	8-27
	5-27. A4 x1, x1/2 and x1/4 Attenuator Adjustment ....	5-14			
	5-28. A4 x1, x1/10 and x1/100 Attenuator Adjustment ....	5-15			

**LIST OF TABLES**

Number	Title	Page	Number	Title	Page
4-1.	Recommended Performance Test Equipment .....	4-0	5-1.	Adjustable Components .....	5-2
4-2.	Test Frequency Accuracy Test	4-6	5-2.	Factory Selected Components	5-3
4-3.	Test Signal Level Variable Range Test .....	4-7	5-3.	Adjustments Requirement .....	5-4
4-4.	Self Operating Test Summary	4-10	5-4.	1-1/2-1/4 Attenuator Adjustments .....	5-16
4-5.	Capacitance Accuracy Tests	4-13	5-5.	1-1/10-1/100 Attenuator Adjustments .....	5-16
4-6.	Resistance Accuracy Tests ..	4-15	5-6.	Display Limits for OSC Level Monitor .....	5-18
4-7.	Frequency Phase Accuracy Tests .....	4-19	5-7.	Signal Level Limits that appear at UNKNOWN Terminals	5-18
4-8.	DC Bias Voltage Test Limits	4-21	5-8.	Adjustment Summary .....	5-21
4-9.	DC Bias Voltage Test Limits	4-22	5-9.	Adjustment Summary .....	5-22
4-10.	Controller Instructions and Operator Responses for Test Program 1 .....	4-25	6-1.	List of Reference Designators and Abbreviations .....	6-1
4-11.	Controller Instructions and Operator Responses for Test Program 2 .....	4-26	6-2.	Manufacturers Code List .....	6-2
4-12.	Controller Instructions and Operator Responses for Test Program 3 .....	4-28	6-3.	Replaceable Parts .....	6-3
4-13.	Controller Instructions and Operator Responses for Test Program 4 .....	4-31	7-1.	Manual Changes by Serial Numbers .....	7-1
			7-2.	Summary of Changes by Assembly .....	7-2
			8-1.	Mnemonic Information .....	8-18
			8-2.	Built-in Self Test Function	8-21

**LIST OF ILLUSTRATIONS**

Number	Title	Page	Number	Title	Page
4-1.	Test Frequency Accuracy Test Setup .....	4-6	5-4.	Waveforms after Adjustments with A4ADJ1 and A4ADJ2 ....	5-7
4-2.	Test Signal Level Variable Range Test Setup ..	4-7	5-5.	Waveforms Typically Adjusted	5-7
4-3.	Self Operating Test Setup ...	4-8	5-6.	A6 Oscillator Adjustment ....	5-8
4-4.	Capacitance Accuracy Test Setups .....	4-11	5-7.	A3 Power Amplifier Adjustment	5-9
4-5.	Resistance Accuracy Test Setup .....	4-14	5-8.	A2 90° Phase Adjustment ....	5-10
4-6.	HP 16074A Quasi-Inductor ...	4-16	5-9.	Lissajous Waveform .....	5-11
4-7.	Option 001 Int DC Bias Supply Test Setup .....	4-20	5-10.	A2 Modulator Zero Offset Preadjustment .....	5-11
4-8.	Option 002 Int DC Bias Supply Test Setup .....	4-21	5-11.	A3 Test Signal Level Monitor Adjustment .....	5-17
4-9.	HP-IB Interface Test Setup .	4-23	5-12.	A1 Range Resistor and A4 Buffer Amp Tracking Adjustment .....	5-19
5-1.	A11 Power Supply Voltage Adjustment .....	5-5	5-13.	A1 Range Resistor Phase Adjustment .....	5-21
5-2.	A4 Process Amplifier DC Offset Adjustment .....	5-6	5-14.	A21 (or A23) Internal DC Bias Supply Adjustment (0 to ±35V) .....	5-23
5-3.	Waveforms before Adjustment	5-7	6-1.	Cabinet Parts .....	6-35



## LIST OF ILLUSTRATIONS

Number	Title	Number	Title	Page
8-1.	Basic Block Diagram .....	8-2		
8-2.	Relationship of DUT Impedance and Source Impedance .....	8-3		
8-3.	A-D Conversion .....	8-4		
8-4.	Concept of Vector Ratio Measurement .....	8-6		
8-5.	Relationship of Range Resistor and Gain Selection .....	8-10		
8-6.	Analog Section Block Diagram	8-13		
8-7.	Control Section Block Diagram .....	8-15		
8-8.	Timing Diagram .....	8-17		
8-9.	How to Use Troubleshooting Guide ....	8-19		
8-10.	Signature Analysis Guide ...	8-24		
8-11.	A10 Key and Display Board Disassembly .....	8-26		
8-12.	Schematic Diagram Notes ....	8-28		
8-13.	Adjustment Locations .....	8-29		
8-14.	Assembly Locations .....	8-30		
8-15.	Analog and Digital Sections Isolation Flow .....	8-31		
8-16.	Analog Section Trouble- shooting to Assembly Level	8-33		
8-17.	Digital Section Trouble- shooting to Assembly Level	8-35		
8-18.	Digital Section Trouble- shooting Flow Diagram AL .	8-37		
8-19.	Digital Section Trouble- shooting Flow Diagram BL .	8-39		
8-20.	Digital Section Trouble- shooting Flow Diagram CL .	8-41		
8-21.	Digital Section Trouble- shooting Flow Diagram DL .	8-43		
8-22.	Digital Section Trouble- shooting Flow Diagram EL .	8-45		
8-23.	Digital Section Trouble- shooting Flow Diagram FL .	8-47		
8-24.	Digital Section Trouble- shooting Flow Diagram GL .	8-49		
8-25.	A1 Range Resistor and Null Detector Assembly Troubleshooting Tree .....	8-50		
8-26.	A1 Range Resistor and Null Detector Assembly Component Locations .....	8-51		
8-27.	A1 Range Resistor and Null Detector Assembly Schematic Diagram .....	8-51		
8-28.	A2 Modulator Assembly Troubleshooting Tree .....	8-52		
8-29.	A2 Modulator Assembly Component Locations .....	8-53		
8-30.	A2 Modulator Assembly Schematic Diagram .....	8-53		
8-31.	A3 Power Amplifier Assembly Troubleshooting Tree .....	8-54		
8-32.	A3 Power Amplifier Assembly Component Locations .....	8-55		
8-33.	A3 Power Amplifier Assembly Schematic Diagram .....	8-55		
8-34.	A4 Process Amplifier Assembly Troubleshooting Tree .....	8-56		
8-35.	A4 Process Amplifier Assembly Component Locations .....	8-57		
8-36.	A4 Process Amplifier Assembly Schematic Diagram .....	8-57		
8-37.	A5 A-D Converter Assembly Troubleshooting Tree .....	8-58		
8-38.	A5 A-D Converter Assembly Component Locations .....	8-59		
8-39.	A5 A-D Converter Assembly Schematic Diagram .....	8-59		
8-40.	A6 Oscillator Assembly Troubleshooting Tree .....	8-60		
8-41.	A6 Oscillator Assembly Component Locations .....	8-61		
8-42.	A6 Oscillator Assembly Schematic Diagram .....	8-61		
8-43.	A7 Peripheral Control Assem- bly Component Locations ..	8-63		
8-44.	A7 Peripheral Control Assem- bly Schematic Diagram ....	8-63		
8-45.	A8 Display Control Assembly Component Locations .....	8-65		
8-46.	A8 Display Control Assembly Schematic Diagram .....	8-65		
8-47.	A9 MPU Assembly Component Locations .....	8-67		
8-48.	A9 MPU Assembly Schematic Diagram .....	8-67		
8-49.	A10 Display and Key Assembly Component Locations .....	8-69		
8-50.	A10 Display and Key Assembly Schematic Diagram .....	8-69		
8-51.	A11 Power Supply Assembly Component Locations .....	8-71		
8-52.	A11 Power Supply Assembly Schematic Diagram .....	8-71		
8-53.	A21 DC Bias ( $\pm 35V$ ) Assembly Component Locations .....	8-73		
8-54.	A21 DC Bias ( $\pm 35V$ ) Assembly Schematic Diagram .....	8-73		
8-55.	A22 HP-IB Assembly Component Locations .....	8-75		
8-56.	A22 HP-IB Assembly Schematic Diagram .....	8-77		
8-57.	A23 DC Bias ( $\pm 100V$ ) Assembly Component Locations .....	8-79		
8-58.	A23 DC Bias ( $\pm 100V$ ) Assembly Schematic Diagram .....	8-79		

Table 4-1. Recommended Performance Test Equipment.

Equipment	Critical Specifications	Recommended Model/Note
Capacitance Standards	<p>1pF <math>\pm 0.03\%</math>                      10pF <math>\pm 0.03\%</math>                      100pF <math>\pm 0.03\%</math>                      1000pF <math>\pm 0.03\%</math>                      Useable frequencies: up to 10MHz</p>	<p>HP 16381A                      HP 16382A                      HP 16383A                      HP 16384A</p>
Resistance Standards	<p>0.1<math>\Omega</math> <math>\pm 10\%</math>                      1<math>\Omega</math> <math>\pm 10\%</math>                      10<math>\Omega</math> <math>\pm 10\%</math>                      100<math>\Omega</math> <math>\pm 0.03\%</math>                      1000<math>\Omega</math> <math>\pm 0.03\%</math>                      10k<math>\Omega</math> <math>\pm 0.03\%</math>                      100k<math>\Omega</math> <math>\pm 0.03\%</math>                      Useable frequencies: up to 10MHz</p>	<p>HP 16074A                      Standard                      Resistor Set</p>
Frequency Counter	<p>Maximum frequency: &gt;10MHz                      Accuracy: 0.001% (<math>1 \times 10^{-5}</math>)</p>	<p>HP 5314A</p>
RF Voltmeter	<p>Voltage range: 1mV to 3V rms f.s.                      Bandwidth: 10kHz to 10MHz                      Accuracy: 1%</p>	<p>HP 3400A</p>
DC Voltmeter	<p>Voltage range: 10mV to 100V f.s.                      Sensitivity: 0.1mV min.                      Accuracy: 0.05%                      Input impedance: &gt;10M<math>\Omega</math></p>	<p>HP 3465A/B</p>
Test Cable	<p>BNC to BNC cable</p>	<p>1 ea.</p>
Test Cable	<p>BNC to BNC cable (<math>\leq 10</math>cm)                      (Replaceable by Open Termination                      included in HP 16074A).</p>	<p>2 ea.</p>
Bias Controller	<p>(Needed for Option 001 or 002                      Internal DC Bias Supply Test).</p>	<p>HP 16023B</p>
Test Fixture	<p>(Needed for Option 001 Internal                      DC Bias Supply Test).</p>	<p>HP 16047A</p>
Test Leads	<p>(Needed for Option 002 Internal                      DC Bias Supply Test).</p>	<p>HP 16048A</p>
HP-IB Controller	<p>(Needed for Option 101 HP-IB                      Interface Test).</p>	<p>HP 9825A/                      w 98210A/                      w 98213A/                      w 98034A</p>
Signature Analyzer		<p>HP 5004A *</p>
Oscilloscope	<p>Bandwidth: 10MHz min                      Vertical Sensitivity: 5mV/div                      Horizontal Sweep Rate: 1<math>\mu</math>s/div</p>	<p>HP 1740A *</p>

\*..... is used for troubleshooting.

## SECTION IV PERFORMANCE TESTS

### 4-1. INTRODUCTION.

4-2. This section provides the check procedures to verify the 4274A specifications listed in Table 1-1. All tests can be performed without access to the interior of the instrument. A simpler operational test is presented in Section III under Self Test (paragraph 3-5). The performance test procedures in this section can also be used to do an incoming inspection of the instrument and to verify whether the instrument meets its specified performance after troubleshooting or making adjustments. If specifications are found to be out of limits, check that controls are properly set, and then proceed to adjustments or troubleshooting.

Note

Allow a 30-minute warm-up and stabilization period before conducting any performance test.

### 4-3. EQUIPMENT REQUIRED.

4-4. Equipment required for the performance tests is listed in Table 4-1 Recommended Performance Test Equipment. Any equipment whose characteristics equal the critical specifications given in the table may be substituted for the recommended model(s).

Accuracy checks in this section use 16380 series standard capacitors (16381A, 16382A, 16383A and 16384A) and the 16074A Standard Resistor Set. These accessory standards have the specifications which satisfy the performance requirements for the accuracy checks and are especially fit for use as 4274A accuracy test standards.

Note

All components used as standards should be calibrated by an instrument whose specifications are traceable to NBS, PTB, LNE, NRC, JEMIC, or equivalent standards group; or all components should be calibrated directly by an authorized calibration organization such as NBS. The calibration cycle should be determined by the stability specification for each component.

### 4-5. TEST RECORD.

4-6. Results of the performance tests may be tabulated on the Test Record at the end of these procedures. The Test Record lists all the tested specifications and their acceptable limits. Test results recorded at incoming inspection can be used for comparison in periodic maintenance and troubleshooting and after repairs or adjustments.

### 4-7. CALIBRATION CYCLE.

4-8. This instrument requires periodic verification of performance. Depending on the use and environmental conditions, the instrument should be checked with the following performance tests at least once every year. To maximize instrument "up time", the recommended preventive maintenance frequency for the 4274A is twice a year.

Performance Test Table

Accuracy Test Considerations .....	4-2	Inductance Accuracy Test .....	4-16
Accuracy Test Standards .....	4-4	Frequency-Phase Accuracy Test .....	4-18
Test Frequency Accuracy Test .....	4-6	Opt. 001 Int. DC Bias Test .....	4-20
Test Signal Level Test .....	4-7	Opt. 002 Int. DC Bias Test .....	4-21
Self Operating Test .....	4-8	Opt. 101 HP-IB Interface Test ....	4-23
Capacitance Accuracy Test .....	4-11		
Resistance Accuracy Test .....	4-14		

## ACCURACY TEST CONSIDERATIONS

This paragraph discusses how the 4274A accuracy is tested and verified. As the 4274A has (because of its wider measurement capabilities), to a great extent, expanded the selectable measurement parameters, frequency and range along with high accuracy (as its features), the accuracy check ranges that need to be verified include some critical measuring regions where accuracies are difficult to be directly compared to the specifications by using standards.

Measurement accuracies are tested by reading the displays when measuring standard capacitors, inductors, resistors and other devices as references whose values are calibrated and certified by transfer of values from national standards. Certain 4274A measurement range capabilities are out of the applicable ranges of the practical standards, so such standards, to satisfy the requirements for checking on all the 4274A ranges, will be unavailable. The method then, is to check accuracies on the specific ranges at which the standards are applicable. Further corroboration for the entire range (to the instrument performance limits) is done by particular tests for evaluating full range accuracy.

## Theoretical Background of Accuracy Checks.

The 4274A, in accord with its measurement principles, detects the vector impedance (or its reciprocal value: admittance) of the unknown sample to be tested. The various measurement data provided, with respect to the 13 possible measurement parameters (L, C, R, D, etc.), are arithmetically derived from measured values of the right-angle vector components (resistance and reactance). For example, the capacitance value of a sample is calculated by the following equation relative to the capacitance-to-reactance values:

$$C_x = \frac{1}{2\pi f X_m}$$

Where,  $C_x$  is capacitance value of sample,  
 $f$  is measurement frequency,  
 $X_m$  is measured reactance value of sample.

As discussed above, each measurement parameter is interrelated with the impedance (or admittance) value so the accuracies on all ranges can be verified if the instrument satisfies specified accuracies for each one of its resistive and reactive measurement parameters, e.g. resistance and capacitance from the lowest through the highest test frequencies.

It is important to note that the accuracy is based on arithmetic relationships as are the parameter relationships. This theoretical background is pertinent to the corroboration of the accuracy evaluations which are done by simplified test procedures instead of time-consuming-tests on the 900 (approximately) possible combinations of the fundamental test parameters (measurement parameter, frequency, range, etc.).

## ACCURACY TEST CONSIDERATIONS

## Corroboration Check Considerations

The test for measurement accuracy with respect to the vector impedance is made on specific ranges using standards, and on the other ranges by using alternate methods which are (theoretically and experimentally) proven to be practicable for verification of the ranges which otherwise would be uncertifiable because of the limitations of the standards. If the end results of these checks meet all the individual test limits, the instrument should satisfy its specified accuracies across its entire range. Then, how can these methods be explained? Let's look at the performance test articles.

Accuracy test procedures include checks for the following circuit sections:

- 1) Bridge Circuit Range Resistors.
- 2) Range Multiplier.
- 3) Bridge Balance Control.
- 4) Phase Detector.
- 5) A-D (Analog to Digital) Converter.

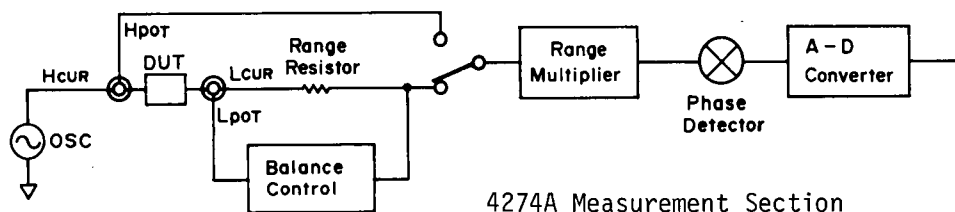

**CAPACITANCE ACCURACY TEST** verifies Range Resistor accuracy for the reactive impedance measurement from the lowest through the highest test frequencies. (Balance Control linearity and normal operations of the Phase Detector and A-D Converter are also verified).

**RESISTANCE ACCURACY TEST** does its verification in a manner similar to that for the Capacitance Accuracy Test, but for resistive impedance measurements. Thus, accuracies for both reactive and resistive components of the vector impedance are verified.

**SELF OPERATING TEST** verifies the multiples of the Range Multiplier which extends the measurement ranges. The A-D Converter accuracy is also checked by this combined self-test function which enables automatic check of each one of these circuits.

**FREQUENCY-PHASE ACCURACY TEST** verifies phase-flatness characteristics (minimum phase shift) of the overall measurement section and Phase Detector phase accuracy from the lowest through the highest test frequencies.

## Note

A set of detection phases, each different by 90 degrees, is used in the Phase Detector. If their relative phase angles are exactly 90 degrees, the phase relationships of the detection phases on the vector DUT Voltage (or current) detected have no influence on the resultant accuracy. The accuracy of the right-angle detection phases is verified by both this test and dissipation factor checks associated with the Capacitance Accuracy Test.

## ACCURACY TEST STANDARDS

## 1) Standard Capacitors.

The HP 16380 series standard capacitors, featuring the four terminal pair configuration, are recommended for use as performance test standards. The four standard capacitors 16381A (1pF), 16382A (10pF), 16383A (100pF) and 16384A (1000pF) are calibrated at 0.01% accuracy (within 0.1% of their nominal capacitance values) at 1kHz. For values at frequencies to 10MHz, an extrapolation of the calibrated values at 1kHz is used (this is based on the careful consideration of their inherent residual parameter values and on the actual test measurement to verify the frequency dependency of the values). Capacitance values at frequencies up to 10MHz are read from the graph given on the data sheet of each standard.

## Note

A high capacitance standard, useable in the high frequency region, is unavailable. Here's why:

A 10 $\mu$ F capacitor, for example, has an impedance value of 0.16 $\Omega$  at 100kHz. A capacitance standard would have, in addition, residual impedances which could not be neglected when compared to the pure impedance of 0.16 $\Omega$ . Thus, an attempt at tests which would use the standard capacitor at the higher operating frequency ranges is not practicable.

## 2) Standard Resistors.

The standard resistors used for accuracy checks should be practically pure resistances and should maintain an extremely low order of residual reactance at frequencies to 100kHz. The HP 16074A Standard Resistor Set, especially designed as standards useable over a broad frequency region, with four terminal pair configurations, is suitable for the accuracy checks. These thin film resistors, which ensure negligible low stray capacitance and less skin effect, provide the standard resistance values of 0.1 $\Omega$ , 1 $\Omega$  and 10 $\Omega$  at  $\pm 10\%$  and 100 $\Omega$ , 1000 $\Omega$ , 10k $\Omega$  and 100k $\Omega$  at  $\pm 0.01\%$  calibration accuracies to 10MHz (1MHz at 100k $\Omega$ ). Open (OS) and short (0 $\Omega$ ) terminations which facilitate optimum zero offset adjustment as well as two quasi-inductors for inductance accuracy checks are included in the 16074A.

## Note

The 0.1 $\Omega$ , 1 $\Omega$  and 10 $\Omega$  resistors are used as the (pure resistance) reference samples in the Frequency-Phase Accuracy Test.

## 3) Standard Inductors.

The 4274A inductance accuracy is theoretically certified if the capacitance accuracy meets the specifications. Generally, inductors have unwanted parasitic impedances to some extent (that is, coil resistance and distributed capacitance). As these residuals significantly dominate the inductance values at high frequencies, inductance standards useable in RF region (higher than about 100kHz) are substantially unavailable. Inductors with higher inductance values have lower frequency limits.

ACCURACY TEST STANDARDS

If it is desired to check inductance measurement accuracy on least at one range, a quasi-inductor may be useful as a substitution test sample. The quasi-inductor offers an equivalent inductance (when connected to the 4274A) by a simple network circuit consisting of a capacitor and resistors. A quasi-inductor circuit is shown in the figure below:

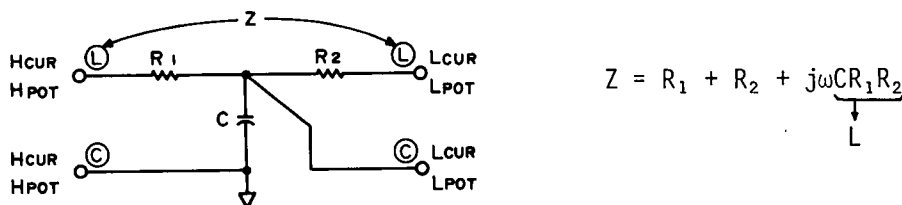

The equivalent inductance value is given by the equation:  
 $L = C \cdot R_1 \cdot R_2$

The values of R and C are respectively measured to calculate the equivalent inductance value (prior to the inductance accuracy check). The HP 16074A Quasi-inductors offer the composite inductance values of 100µH and 100mH. Useable frequency ranges for these inductors are given in the table below:

Sample	Useable frequency range	Recommended test frequency
100µH	100kHz to 10MHz	100kHz
100mH	10kHz to 1MHz	10kHz

Note

Component resistors R<sub>1</sub> and R<sub>2</sub> in the quasi circuit may be measured at dc with a high accuracy DMM. These high stability resistors need only be re-calibrated at the recommended calibration period of 6 months. The capacitors should be checked before each test.

GENERAL

The standards should be of the four terminal pair configuration design to provide compatibility with the instrument. This minimizes reduction in reliability of the values due to the effects of the residuals associated with cabling and connections.

**PERFORMANCE TESTS**

4-9. TEST FREQUENCY ACCURACY TEST

4-10. This test verifies that test signal frequencies for 4274A meet the specified frequency accuracy of 0.01%.

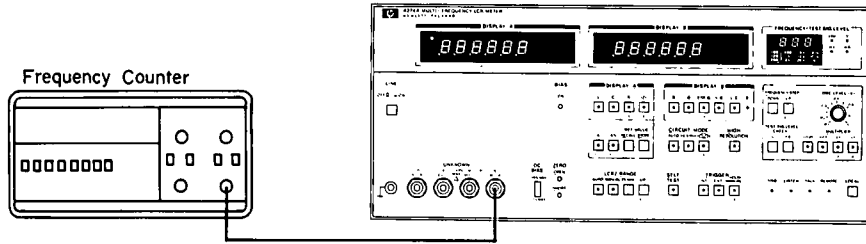

Figure 4-1. Test Frequency Accuracy Test Setup.

EQUIPMENT:

- Frequency Counter ..... HP 5314A.
- Test cable ..... BNC to BNC cable.

PROCEDURE:

1. Connect BNC to BNC cable to 4274A UNKNOWN H<sub>CUR</sub> terminal and to frequency counter input as shown in Figure 4-1.
2. Set 4274A controls as follows:
  - MULTIPLIER ..... x1
  - OSC LEVEL ..... fully cw
  - Test frequency ..... 1.00kHz
  - DC BIAS switch (rear panel) ..... OFF
  - Other controls ..... any setting
3. Read display output of frequency counter. Frequency readouts must be within 999.9Hz and 1000.1Hz.
4. Change test frequency setting and read frequency counter display output at each of the 11 spot test frequencies (and any optional frequency). Frequency readouts must be within the test limits given in Table 4-2.

Table 4-2. Test Frequency Accuracy Test.

Frequency setting	Test limits
100Hz	99.99 - 100.01Hz
120Hz	119.99 - 120.01Hz
200Hz	199.98 - 200.02Hz
400Hz	399.96 - 400.04Hz
1.00kHz	999.9 - 1000.1Hz
2.00kHz	1.9998 - 2.0002kHz
4.00kHz	3.9996 - 4.0004kHz
10.0kHz	9.999 - 10.0001kHz
20.0kHz	19.998 - 20.002kHz
40.0kHz	39.996 - 40.004kHz
100kHz	99.99 - 100.01kHz
Opt. Freq.	± 0.01%

Note

- 1) Test limits in above table do not account for reading error contributed by measurement errors in the test equipment.
- 2) If this test fails, the instrument requires troubleshooting.



**PERFORMANCE TESTS**

4-11. TEST SIGNAL LEVEL (VARIABLE RANGE- TEST).

4-12. This test verifies that the variable range of the test signal level for the 4274A meets the specified range span of 1mV and 5V rms at every test frequency setting.

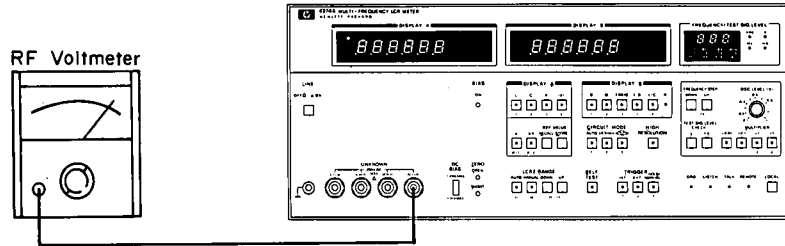

Figure 4-2. Test Signal Level Variable Range Test Setup.

EQUIPMENT:

- RF Voltmeter ..... HP 3400A and HP 3465A/B
- Test cable ..... BNC to BNC cable/BNC to dual banana cable

Note

Use RF Voltmeter calibrated for frequency response of 100Hz to 100kHz.

PROCEDURE:

1. Connect BNC to BNC cable to 4274A UNKNOWN HCUR terminal and to RF voltmeter input as shown in Figure 4-2.
2. Set RF voltmeter range as appropriate to measure voltage of 5V rms.
3. Set 4274A controls as follows:
  - MULTIPLIER ..... x5
  - OSC LEVEL ..... fully cw
  - Test frequency ..... 100kHz
  - DC BIAS switch (rear panel) ..... OFF
  - Other controls ..... Any setting
4. RF voltmeter readout should be 5.00V rms or more (when the value is corrected for the voltmeter frequency response).
5. Change test frequency setting successively to lower frequencies (from 100kHz) and verify that RF voltmeter readout exceeds 5.00V rms at each test frequency setting.
6. Set 4274A controls in accord with table 4-3 and verify that all the test limits given in the table are satisfied.

Table 4-3. Test Signal Level Variable Range Test.

Control settings			Test limits
Test frequency	OSC LEVEL	MULTIPLIER	
Each setting from 100Hz to 100kHz	fully cw	x5	greater than 5.00V rms
Each setting from 100Hz to 100kHz	fully cw	x1	greater than 1.00V rms
Any setting	fully cw	x0.1	greater than 100mV rms
		x0.01	greater than 10.0mV rms
1kHz	fully ccw	x0.01	less than 1.00mV rms (Use 3465A/B)

**PERFORMANCE TESTS**

4-13. SELF-OPERATING TEST

4-14. The Self-operating Test checks operating conditions of the circuits (Range Multiplier for extending measurement capability to higher and lower ranges; Null Detector for bringing bridge into optimum balance; Buffer Amplifiers for accurately detecting potentials across DUT and range resistor; and Integrator for converting analog measurement quantities into digital) which are especially significant for sustaining the specified accuracies. All the tests on these individual circuits can be accomplished easily and simply with the SELF TEST function. To ascertain that these circuits satisfy the performance requirements for ensuring the specified accuracies, display readouts are compared with severe test limits. Because basic circuit operating conditions related to the accuracy are verified in this test, the instrument should be initially checked with this test for acceptability.

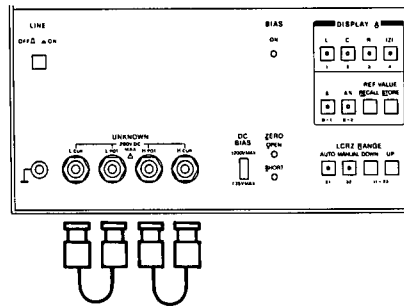

Figure 4-3. Self Operating Test Setup.

EQUIPMENT:

BNC to BNC cable ..... 10cm long, 2 required.

Note

If open (OS) termination of the HP 16074A Standard Resistor set is available, use it instead of BNC to BNC cable.

PROCEDURE:

1. Connect L<sub>CUR</sub> and L<sub>POT</sub> terminals with a BNC to BNC cable as shown in Figure 4-3. Similarly Connect H<sub>CUR</sub> and H<sub>POT</sub> terminals.

CAUTION

VERIFY THAT DC BIAS INDICATOR LAMP DOES NOT LIGHT. IF ILLUMINATED, SET REAR PANEL DC BIAS SWITCH TO OFF.

2. Set test signal frequency to 1.00kHz.
3. Press SELF TEST button and then DISPLAY B function D button.

Note

Self test item number (in this case "1" which means the first step) is displayed in DISPLAY A unit indicator as shown below:



**PERFORMANCE TESTS**

4. DISPLAY A and DISPLAY B readouts should be within the following test limits:
  - DISPLAY A .....  $.00 \pm 160$  counts
  - DISPLAY B .....  $.00 \pm 160$  counts
5. Press DISPLAY B function Q button. Self test item number "2" is displayed.
6. Set test signal level and frequency as follows:
  - MULTIPLIER ..... x1
  - OSC LEVEL ..... fully cw
  - Test frequency ..... 1.00kHz
7. DISPLAY A readout should be within the following test limit:
  - DISPLAY A .....  $-1000.00 \pm 160$  counts.
8. Change test frequency to 100kHz.
9. DISPLAY B readout should be within the following test limit:
  - DISPLAY B .....  $.00 \pm 160$  counts.
10. Press DISPLAY B function ESR/G button. Self test item number "3" is displayed.
11. Set test signal in accord with step 6 and repeat test steps 7, 8 and 9 above with respect to the third self-test step.
12. Press DISPLAY B function X/B button. Self test item number "4" is displayed.
13. Set test signal in accord with step 6 and repeat test steps 7, 8 and 9 above with respect to the fourth self-test step.
14. Press DISPLAY B function L/C button. Self test item number "5" is displayed.
15. Set test signal in accord with step 6 and repeat test steps 7, 8 and 9 with respect to the fifth self-test step.
16. Press DISPLAY A  $\Delta\%$  button. Self test item number "7" is displayed and MULTIPLIER is automatically set to x 0.1.
17. Set test frequency to 10.0kHz.
18. Display readouts should be within the following test limits:
  - DISPLAY A .....  $.00 \pm 160$  counts
  - DISPLAY B .....  $.00 \pm 160$  counts
19. Change test frequency to 100kHz.
20. Display readouts should be within the following test limits:
  - DISPLAY A .....  $.00 \pm 500$  counts
  - DISPLAY B .....  $.00 \pm 500$  counts

## Note

Self test item 6 does not exist.

**PERFORMANCE TESTS**

Table 4-4. Self Operating Test Summary.

Test item	Press button	Control settings			Test Limits	
		MULTIPLIER	OSC LEVEL	Frequency	DISPLAY A	DISPLAY B
1	D	—	—	1.00kHz	.00±160 counts	.00±160 counts
2	Q	x1	fully cw	1.00kHz	-1000.00 ±160 counts	—
		x1	fully cw	100kHz	—	.00±160 counts
3	ESR/G	x1	fully cw	1.00kHz	-1000.00 ±160 counts	—
		x1	fully cw	100kHz	—	.00±160 counts
4	X/B	x1	fully cw	1.00kHz	-1000.00 ±160 counts	—
		x1	fully cw	100kHz	—	.00±160 counts
5	L/C	x1	fully cw	1.00kHz	-1000.00 ±160 counts	—
		x1	fully cw	100kHz	—	.00±160 counts
7	Δ%	x0.1	fully cw	10.0kHz	.00±160 counts	.00±160 counts
		x0.1	fully cw	100kHz	.00±500 counts	.00±500 counts

**PERFORMANCE TESTS**

**4-15. CAPACITANCE ACCURACY TEST.**

4-16. This test checks full scale display capacitance measurement accuracies for various combinations of test signal frequency and test signal level. The capacitance accuracy checks are made by connecting a standard capacitor to the instrument and comparing measurement readouts with the calibrated values of the standard to verify that the instrument meets the 4274A accuracy specifications. Accuracies for dissipation factors of nearly zero are also checked in this test. Since fundamental reference elements, (range resistors and detection phases) required for establishing C and D measurement accuracies (and also accuracies of other measurement parameters) are checked by these narrow range tests, almost all ranges, from minimum to maximum, are being verified.

Freq. Range	100Hz 120Hz	200Hz	400Hz	1kHz	2kHz	4kHz	10kHz	20kHz	40kHz	100kHz
1000fF	/	/	/	/	/	/	/	/		
10pF	/	/	/	/	/	/	/	/		
100pF	/	/	/	/	/	/	/	/		
1000pF	/	/	/	/	/	/	/	/		

Tested range.  Non-applicable range for recommended capacitance standard.

**Note**

Test on capacitance ranges for test frequencies listed above should be done at three test signal MULTIPLIER settings (x5, x1 and x0.1). OSC LEVEL control is set to its fully cw position.

**Note**

Check for dissipation factor accuracies at the same time as that for capacitance accuracies.

**Note**

Check all ranges in parallel ( mode. It is sufficient to check any one range in series ( mode.

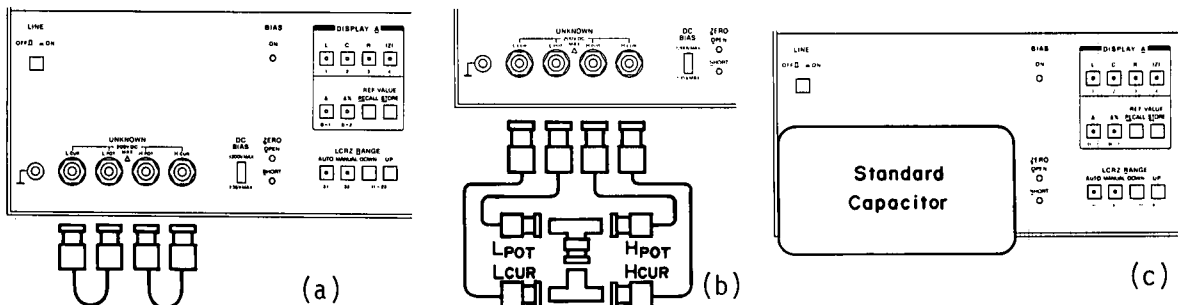

Figure 4-4. Capacitance Accuracy Test Setups.

**EQUIPMENT:**

- Standard capacitors ..... 1pF : HP 16381A  
 ..... 10pF : HP 16382A  
 ..... 100pF : HP 16383A  
 ..... 1000pF : HP 16384A
- BNC to BNC cable ..... 10cm long, 4 ea. required
- BNC Tee adapter ..... -hp- 1250-0781   
 ..... -hp- 1251-0921

**PERFORMANCE TESTS**

Note

- 1) If short ( $0\Omega$ ) and open ( $0S$ ) terminations of the HP 16074A Standard Resistor Set are available, use them for zero offset adjustment instead of BNC to BNC cables and BNC Tee adapters.
- 2) Use BNC to BNC cables of 10cm long or less. Using a longer cable may affect test results.

PROCEDURE:

1. Connect  $L_{CUR}$  and  $L_{POT}$  terminals with a BNC to BNC cable as shown in Figure 4-4 (a). Similarly Connect  $H_{CUR}$  and  $H_{POT}$  terminals.
2. Set 4274A controls as follows:  
DISPLAY A function ..... C  
Deviation measurement function ..... off  
LCRZ RANGE ..... AUTO  
DISPLAY B function ..... D  
CIRCUIT MODE ..... AUTO   
HIGH RESOLUTION ..... on  
SELF TEST ..... off  
TRIGGER ..... INT  
OSC LEVEL ..... fully cw  
MULTIPLIER ..... x5

CAUTION

VERIFY THAT DC BIAS INDICATOR LAMP DOES NOT LIGHT. IF ILLUMINATED, SET REAR PANEL DC BIAS SWITCH TO OFF.

3. Press ZERO OPEN button and wait approximately 20 seconds until "open" offset adjustment is completed ("CAL" letters in DISPLAY A disappear).
4. Connect cables and terminal adapters as shown in Figure 4-4 (b). Connect BNC tee adapters to each other.
5. Press ZERO SHORT button and wait approximately 20 seconds until "short" offset adjustment is completed.
6. Disconnect cables and connect 1pF Standard Capacitor direct to UNKNOWN terminals as shown in Figure 4-4 (c).
7. Set test frequency and test signal level MULTIPLIER in accord with Table 4-5. Capacitance and dissipation factor readouts should be within tolerances given in the table.
8. Change standard capacitor successively to 10pF, 100pF and 1000pF and verify that the instrument satisfies Table 4-5.

Note

Table 4-5 applies to the tests at three MULTIPLIER settings (x5, x1 and x0.1).

**PERFORMANCE TESTS**

Table 4-5. Capacitance Accuracy Tests (part 1 of 2).

Test frequency and Multiplier Setting	Standard capacitance: 1pF		Standard capacitance: 10pF	
	C test limits	D test limits	C test limits	D test limits
100Hz 120Hz 200Hz 400Hz 1.00kHz 2.00kHz	—	—	—	—
4.00kHz, x5 (x1) (x0.1)	—	—	C.V. ±0.016pF (±0.070pF) (±0.610pF)	0±0.00120 (±0.00210) (±0.01110)
10.0kHz, x5 (x1) (x0.1)	—	—	C.V. ±0.013pF (±0.040pF) (±0.310pF)	0±0.00090 (±0.00180) (±0.01080)
20.0kHz, x5 (x1) (x0.1)	—	—	C.V. ±0.012pF (±0.030pF) (±0.310pF)	0±0.00075 (±0.00165) (±0.01065)
40kHz, x5 (x1) (x0.1)	C.V. ±4.6fF (±10fF) (±64fF)	0±0.00230 (±0.00320) (±0.01220)	C.V. ±0.037pF (±0.037pF) (±0.091pF)	0±0.00230 (±0.00230) (±0.00320)
100kHz, x5 (x1) (x0.1)	C.V. ±4.3fF (±7.0fF) (±34fF)	0±0.00170 (±0.00260) (±0.01160)	C.V. ±0.034pF (±0.034pF) (±0.061pF)	0±0.00170 (±0.00170) (±0.00260)

Table 4-5. Capacitance Accuracy Tests (part 2 of 2).

Test frequency and Multiplier Setting	Standard capacitance: 100pF		Standard capacitance: 1000pF	
	C test limits	D test limits	C test limits	D test limits
100Hz, x5 120Hz, (x1) (x0.1)	—	—	C.V. ±1.3pF (±4.0pF) (±31pF)	0±0.00090 (±0.00180) (±0.01080)
200Hz, x5 (x1) (x0.1)	—	—	C.V. ±1.2pF (±3.0pF) (±21pF)	0±0.00075 (±0.00165) (±0.01065)
400Hz, x5 (x1) (x0.1)	C.V. ±0.16pF (±0.70pF) (±6.10pF)	0±0.00120 (±0.00210) (±0.01110)	C.V. ±1.6pF (±1.6pF) (±7.0pF)	0±0.00120 (±0.00120) (±0.00210)
1.00kHz, x5 (x1) (x0.1)	C.V. ±0.13pF (±0.40pF) (±3.10pF)	0±0.00090 (±0.00180) (±0.01080)	C.V. ±1.3pF (±1.3pF) (±4.0pF)	0±0.00090 (±0.00090) (±0.00180)
2.00kHz, x5 (x1) (x0.1)	C.V. ±0.12pF (±0.30pF) (±2.10pF)	0±0.00075 (±0.00165) (±0.01065)	C.V. ±1.2pF (±1.2pF) (±3.0pF)	0±0.00075 (±0.00075) (±0.00165)
4.00kHz, x5 (x1) (x0.1)	C.V. ±0.16pF (±0.16pF) (±0.70pF)	0±0.00120 (±0.00120) (±0.00210)	C.V. ±1.6pF	0±0.00120
10.0kHz, x5 (x1) (x0.1)	C.V. ±0.13pF (±0.13pF) (±0.40pF)	0±0.00090 (±0.00090) (±0.00180)	C.V. ±1.3pF	0±0.00090
20.0kHz, x5 (x1) (x0.1)	C.V. ±0.12pF (±0.12pF) (±0.30pF)	0±0.00075 (±0.00075) (±0.00165)	C.V. ±1.2pF	0±0.00075
40.0kHz, x5 (x1) (x0.1)	C.V. ±0.16pF	0±0.00120	C.V. ±1.6pF	0±0.00120
100kHz, x5 (x1) (x0.1)	C.V. ±0.13pF	0±0.00090	C.V. ±1.3pF	0±0.00090

C.V. = Calibrated Value

**PERFORMANCE TESTS**

4-17. RESISTANCE ACCURACY TEST

4-18. This test checks resistance measurement accuracies for full scale displays at each of the 11 spot standard test frequencies. The resistance accuracy checks are made by connecting a standard resistor to the instrument and comparing the measurement readouts with the calibrated values of the standard to verify that the 4274A meets accuracy specifications. As the capacitance accuracy test (in paragraph 4-15) and this resistance accuracy test check the respective elements pertinent to the right-angle impedance vector, measurement accuracies for both resistive and reactive measurement parameters are thus being verified.

Resistance accuracy check ranges

Freq. Range	100Hz	120Hz	200Hz	400Hz	1kHz	2kHz	4kHz	10kHz	20kHz	40kHz	100kHz
100kΩ											
10kΩ											
1000Ω											
100Ω											

All ranges should be tested.

Note

The tests on resistance ranges and test frequencies listed above should be done at three test signal MULTIPLIER settings (x5, x1 and x0.1). OSC LEVEL control is set to its fully cw position.

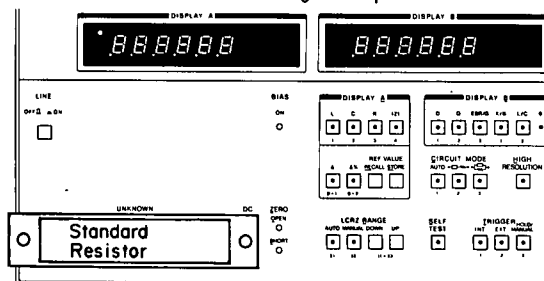

Figure 4-5. Resistance Accuracy Test Setup.

EQUIPMENT:

Standard Resistors ..... 100Ω }  
 ..... 1000Ω } HP 16074A Standard  
 ..... 10kΩ } Resistor Set  
 ..... 100kΩ }

PROCEDURE:

1. Set 4274A controls as follows:

DISPLAY A function ..... R  
 Deviation measurement function ..... off  
 LCRZ RANGE ..... AUTO  
 CIRCUIT MODE ..... AUTO  
 HIGH RESOLUTION ..... on



**PERFORMANCE TESTS**

SELF TEST ..... off  
 TRIGGER ..... INT  
 OSC LEVEL ..... fully cw  
 MULTIPLIER ..... x5

**CAUTION**

VERIFY THAT DC BIAS INDICATOR LAMP DOES NOT LIGHT. IF ILLUMINATED, SET REAR PANEL DC BIAS SWITCH TO OFF.

**Note**

If Capacitance Accuracy Test (paragraph 4-15) has not been performed before doing this test, perform zero offset adjustment in accord with Capacitance Accuracy Test steps 1, 3, 4 and 5.

2. Connect 100Ω standard resistor direct to UNKNOWN terminals as shown in Figure 4-5.
3. Set test frequency and test signal level MULTIPLIER in accord with Table 4-6. Resistance readouts should be within tolerances given in the table.
4. Change standard resistor successively to 1000Ω, 10kΩ and 100kΩ and verify that the instrument satisfies Table 4-6.

**Note**



1. Table 4-6 applies to tests at three MULTIPLIER settings (x5, x1 and x0.1).
2. Measurement CIRCUIT MODE is automatically set to  mode on 100Ω range and to  mode on other ranges.

Table 4-6. Resistance Accuracy Tests.

Test Frequency	Test Limits			
	100Ω	1000Ω	10kΩ	100kΩ
All Frequencies	C.V. ±0.13Ω	C.V. ±4.0Ω	C.V. ±40Ω	C.V. ±400Ω

C.V. = Calibrated value of standard resistor

**PERFORMANCE TESTS**

4-19. INDUCTANCE ACCURACY TEST (Confirmation Test).

4-20. Inductance accuracy is verified if the instrument meets both capacitance and resistance accuracy test limits. If it is desired to confirm the inductance accuracy on at least at one range, perform the following test:

Note

This confirmation test does not necessarily have to be done.

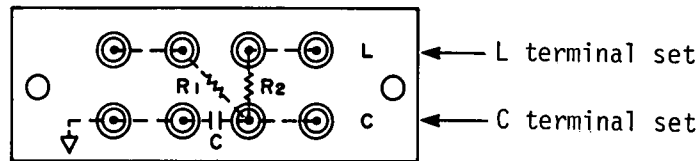

Figure 4-6. HP 16074A Quasi-inductor.

(Internal Connection Configuration)  
 is shown in the figure.

EQUIPMENT:

Quasi-inductor ..... from HP 16074A Standard Resistor Set.

PROCEDURE:

1. Set 4274A controls as follows:

- DISPLAY A function ..... C
- Deviation measurement function ..... off
- LCRZ RANGE ..... AUTO
- CIRCUIT MODE .....
- HIGH RESOLUTION ..... on
- SELF TEST ..... off
- TRIGGER ..... INT
- OSC LEVEL ..... fully cw
- MULTIPLIER ..... x5

CAUTION

VERIFY THAT DC BIAS INDICATOR LAMP DOES NOT LIGHT. IF ILLUMINATED, SET REAR PANEL DC BIAS SWITCH TO OFF.

Note

If Capacitance Accuracy Test (paragraph 4-15) has not been performed before doing this test, perform a zero offset adjustment in accord with Capacitance Accuracy Test steps 1, 3, 4 and 5.

**PERFORMANCE TESTS**

---

100 $\mu$ H range check

2. Connect 100 $\mu$ H quasi-inductor "C" terminals direct to 4274A UNKNOWN terminals. See Figure 4-6.
3. Set test signal frequency to 100kHz.
4. Read displayed capacitance value ( $C_m$ ).
5. Calculate composite inductance value ( $L_m$ ) from the calibrated values for the component resistors ( $R_1$  and  $R_2$ ) and the capacitance value obtained in step 4 procedure.  $L_m$  is given by equation:  
$$L_m = R_1 \cdot R_2 \cdot (C_m - 7.1pF) (H)$$
6. Disconnect quasi-inductor "C" terminals from UNKNOWN terminals. Connect its "L" terminals to 4274A UNKNOWN terminals.
7. Set DISPLAY A function to "L".
8. Inductance display readout should be within  $\pm 0.23\mu H$  of the calculated  $L_m$  value.
9. Disconnect quasi-inductor sample.

100mH range check

10. Check 100mH range using 100mH quasi-inductor and procedures similar to those described in steps 2 through 7. Set test frequency to 1.00kHz during this test.

## Note

Calculate  $L_m$  value by the following equation (instead of the equation given in step 5):

$$L_m = R_1 \cdot R_2 \cdot C_m (H)$$

11. Inductance display readout should be within  $\pm 0.40mH$  of the calculated  $L$  value.

**PERFORMANCE TESTS**

4-21. FREQUENCY-PHASE ACCURACY TEST

4-22. This test checks phase accuracies to ascertain accurate detection of the vector impedance components which are the source of the arithmetic measurement data. The frequency-phase accuracy test is made by connecting a resistor with extremely low reactive elements and by reading reactance display values (almost zero) to verify that the impedance of the DUT is being accurately detected with respect to the right-angle vector components.

Frequency-Phase Accuracy Check Ranges

R range	Test frequency
1000mΩ	100Hz to 100kHz
10Ω	100Hz to 100kHz

Note

The test should be done at three test signal MULTIPLIER settings (x5, x1 and x0.1). OSC LEVEL control is set to its fully cw position.

EQUIPMENT:

Resistor .....	1Ω 10Ω	} HP 16074A Standard Resistor Set
Terminator .....	0Ω open	

Note

The resistors used as references in this test have been designed to maintain extremely low order (residual) reactance at frequencies to 10MHz. 0Ω and open terminators are specially matched to these two resistors in order to ensure an optimum zero offset adjustment.

PROCEDURE:

1. Connect open terminator direct to UNKNOWN terminals as shown in Figure 4-5.

2. Set 4274A controls as follows:

DISPLAY A function .....	R
Deviation measurement function .....	off
LCRZ RANGE .....	AUTO
DISPLAY B function .....	X
CIRCUIT MODE .....	AUTO
HIGH RESOLUTION .....	on
SELF TEST .....	off
TRIGGER .....	INT
OSC LEVEL .....	fully cw
MULTIPLIER .....	x5

**PERFORMANCE TESTS**

## CAUTION

VERIFY THAT DC BIAS INDICATOR LAMP DOES NOT LIGHT. IF ILLUMINATED, SET REAR PANEL DC BIAS SWITCH TO OFF.

3. Press ZERO OPEN button and wait approximately 20 seconds until "open" offset adjustment is completed ("CAL" letters in DISPLAY A disappear).
4. Disconnect open terminator and connect  $0\Omega$  terminator direct to UNKNOWN terminals.
5. Press ZERO SHORT button and wait approximately 20 seconds until "short" offset adjustment is completed.
6. Disconnect  $0\Omega$  terminator and connect  $1\Omega$  test resistor direct to UNKNOWN terminals.
7. Set test frequency and test signal level MULTIPLIER in accord with Table 4-7. Reactance display readouts should be within tolerances given in the table.
8. Connect  $10\Omega$  test resistor in place of  $1\Omega$  resistor and verify that Table 4-7 is satisfied.

## Note

Table 4-7 applies to tests at three MULTIPLIER settings (x5, x1 and x0.1).

Table 4-7. Frequency-Phase Accuracy Tests.

Test frequencies	Reactance test limits	
	$1000m\Omega$	$10\Omega$
100Hz to 100kHz	$0\pm 1.50m\Omega$	$0\pm 0.0130\Omega$

**PERFORMANCE TESTS**

4-23. INT DC BIAS SUPPLY TEST (OPTION 001)

4-24. This test verifies that the Option 001 Internal DC BIAS Supply applies the specified bias voltages to the device under test.

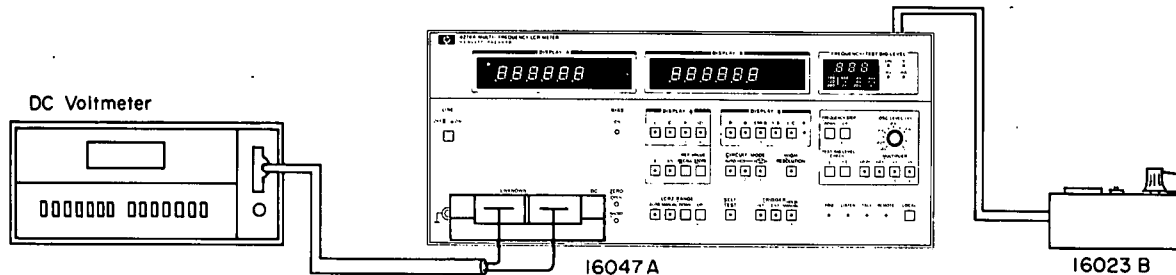

Figure 4-7. Option 001 Int DC Bias Supply Test Setup.

EQUIPMENT:

DC Voltmeter .....	HP 3465A/B
Test Fixture .....	HP 16047A
Bias Controller .....	HP 16023B

PROCEDURE:

1. Set 4274A front panel DC BIAS switch to  $\pm 35V$  MAX position. Attach 16047A Test Fixture to UNKNOWN terminals.
2. Connect 16023B DC Bias Controller to rear panel INT DC BIAS CONTROL connector.

CAUTION

BEFORE OPERATING DC BIAS SWITCH, VERIFY THAT DC BIAS VOLTAGE HAS BEEN SET TO ZERO VOLTS.

3. Set rear panel DC BIAS switch to INT  $\pm 35V/100V$  ( $\leq 1\mu F$ ) position.
4. Connect an appropriate pair of wire leads between dc voltmeter input and 16047A Test Fixture (see Figure 4-7).
5. Set dc bias voltage into 16023B DC Bias Controller in accord with Table 4-8. DC voltmeter readouts should be identical with the bias setting voltages within tolerances given in the table.

Note

To change bias voltage:

1. Set a new bias voltage value into the three digit thumbwheel switch of the 16023B.
2. Press 16023B ENTER button (this actuates the 4274A to read the new value).

**PERFORMANCE TESTS**

Table 4-8. DC Bias Voltage Test Limits.

DC Bias Setting	Tolerance	DC Bias Setting	Tolerance
.000V	-.0020 — .0020V	.100V	.0975 — .1025V
.001	-.0010 — .0030	.200	.1970 — .2030
.002	.0000 — .0040	.300	.2965 — .2035
.003	.0010 — .0050	.400	.3960 — .4040
.004	.0020 — .0060	.500	.4955 — .5045
.005	.0030 — .0070	.600	.5950 — .6050
.006	.0040 — .0080	.700	.6945 — .7055
.007	.0050 — .0090	.800	.7940 — .8060
.008	.0060 — .0100	.900	.8935 — .9065
.009	.0070 — .0110	1.00	.9910 — 1.009
.010	.0080 — .0120	2.00	1.986 — 2.014
.020	.0179 — .0221	3.00	2.982 — 3.018
.030	.0279 — .0321	4.00	3.977 — 4.023
.040	.0378 — .0422	5.00	4.972 — 5.028
.050	.0478 — .0522	6.00	5.967 — 6.033
.060	.0577 — .0623	7.00	6.962 — 7.038
.070	.0677 — .0723	8.00	7.958 — 8.042
.080	.0776 — .0824	9.00	8.953 — 9.047
.090	.0876 — .0924	10.0	9.930 — 10.07
		20.0	19.88 — 20.12
		30.0	29.82 — 30.16

Note

When dc bias voltage is measured at rear panel INT DC BIAS MONITOR connector, voltmeter readout will be somewhat lower than the actual (applied) voltage because of monitor output impedance (30kΩ). Measured voltage value Em is:

$$E_m = E_{\text{bias}} \times \frac{Z_i}{30 + Z_i} \text{ (V)}$$

Where, Zi is voltmeter input impedance (in kΩ).

4-25. INT DC BIAS SUPPLY TEST (OPTION 002)

4-26. This test verifies that the Option 002 Internal DC Bias Supply applies the specified bias voltages to the device under test.

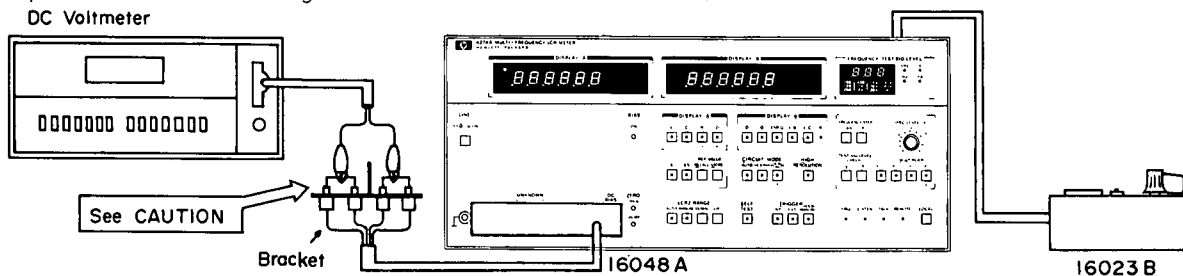

Figure 4-8. Option 002 Int DC Bias Supply Test Setup.

EQUIPMENT:

- DC Voltmeter ..... HP 3465A/B
- Test Leads ..... HP 16048A
- Bias Controller ..... HP 16023B

**PERFORMANCE TESTS**

PROCEDURE:

1. Set 4274A front panel DC BIAS switch to  $\pm 200V$  MAX position. Connect 16048A Test Leads to UNKNOWN terminals.
2. Connect 16023B DC BIAS Controller to rear panel INT DC BIAS CONTROL connector.

CAUTION

BEFORE OPERATING DC BIAS SWITCH, VERIFY THAT DC BIAS VOLTAGE HAS BEEN SET TO ZERO VOLTS.

3. Set rear panel DC BIAS switch to INT  $\pm 35V/100V$  ( $\leq 1\mu F$ ) position.
4. Connect 16048A Test Leads to dc voltmeter input (see Figure 4-8).

**⚠ CAUTION**

DO NOT TOUCH BNC CONNECTOR CENTER PIN WHERE A LIVE VOLTAGE MAY EXIST.

5. Set dc bias voltage into 16023B DC Bias Controller switch in accord with Table 4-9. DC Voltmeter readouts should be identical with the bias setting voltages within tolerances given in the table.

Note

To change bias voltage:

1. Set a new bias voltage value into the three digit thumbwheel switch of the 16023B.
2. Press 16023B ENTER button (this actuates the 4274A to read the new value).

Table 4-9. DC Bias Voltage Test Limits.

DC Bias Setting	Tolerance	DC Bias Setting	Tolerance
00.0V	-0.040 - 0.040V	05.0V	4.86 - 5.14V
00.1	0.058 - 0.142	06.0	5.84 - 6.16
00.2	0.156 - 0.244	07.0	6.82 - 7.18
00.3	0.254 - 0.346	08.0	7.80 - 8.20
00.4	0.352 - 0.448	09.0	8.78 - 9.22
00.5	0.450 - 0.550	10.0	9.76 - 10.24
00.6	0.548 - 0.652	20.0	19.56 - 20.44
00.7	0.646 - 0.754	30.0	29.37 - 30.63
00.8	0.744 - 0.856	40.0	39.17 - 40.83
00.9	0.842 - 0.958	50.0	48.97 - 51.03
01.0	0.940 - 1.060	60.0	58.77 - 61.23
02.0	1.920 - 2.08	70.0	68.58 - 71.42
03.0	2.90 - 3.10	80.0	78.38 - 81.62
04.0	3.88 - 4.12	90.0	88.18 - 91.82

Note

When dc bias voltage is measured at rear panel INT DC BIAS MONITOR connector, voltmeter readout will be somewhat lower than the actual bias voltage. Refer to note in Paragraph 4-24.



**PERFORMANCE TESTS**

4-27. HP-IB INTERFACE TEST (OPTION 101 ONLY)

4-28. This test verifies that the HP-IB circuitry has the capabilities (listed in Table 3-10) to correctly communicate between external HP-IB devices and the 4274A through the interface bus cable.

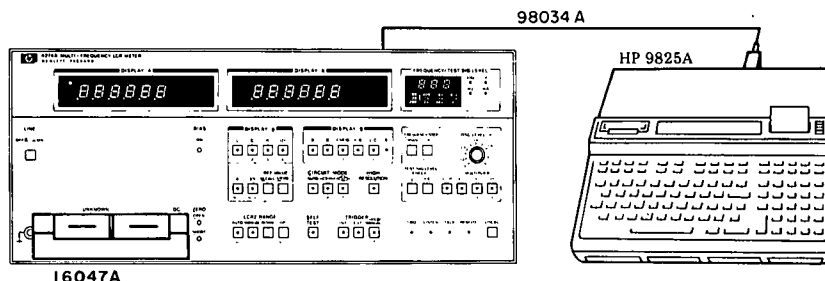

Figure 4-9. HP-IB Interface Test Setup.

EQUIPMENT:

- Calculator ..... HP 9825A
- ROM ..... HP 98210A, 98213A
- Interface Card with cable ..... HP 98034A

Sample capacitor (1000pF ~ 1000µF)

PROCEDURE:

1. Turn power switches of both the 4274A and 9825A to OFF.
2. Connect 98034A Interface Card with cable between 9825A I/O slot and 4274A rear panel HP-IB connector as shown in Figure 4-9.
3. Install required ROM blocks in 9825A ROM slots.
4. Set 98034A Select Code Switch dial to select code 7 (using a screwdriver).
5. Remove 4274A top cover.
6. Set 4274A A22S1 HP-IB Control Switch to following settings:
  - bit 1~5 : 10001 (17 in binary code)
  - bit 6 : 0
  - bit 7 : 0
7. Replace top cover.
8. Connect 16047A Test Fixture to 4274A UNKNOWN terminals.
9. Turn 4274A and 9825A ON.
10. Set 4274A controls as follows:
  - OSC LEVEL ..... 1
  - 16047A Test Fixture ..... Open
  - Other Controls ..... Initial control settings.
11. Load test program as shown on Pages 4-24 through 4-27 in calculator.
12. Execute the program.
13. Check that 4274A display, 9825A display, and printed data are in accord with Controller Instructions and Operator Responses for each test program.
14. Perform steps 10 thru 13 with respect to individual test programs and verify that 4274A and 9825A correctly communicates through the HP-IB interface.

---

**PERFORMANCE TESTS**

---

## TEST PROGRAM 1

## [PURPOSE]

This test verifies that 4274A Opt. 101 has the following capabilities:

- (1) Remote/Local Capability.
- (2) Local Lockout.
- (3) Talk Address Disabled by Listen Address.
- (4) Listen Address Disabled by Talk Address.

## [PROGRAMMING]

```

0: "REMOTE/LOCAL TEST":
1: dim AS[1]
2: 0+A
3: rds(717)+B
4: prt "REMOTE/LOCAL TEST";spc 3
5: rem 7
6: wrt 717,"T1";ent "LISTEN= 1 ,TALK= 0 ,REMOTE= 1",AS
7: if AS="n";1+A
8: cli 7;ent "LISTEN= 0 ,TALK= 0 ,REMOTE= 1",AS
9: if AS="n";1+A
10: lcl 7;ent "LISTEN= 0 ,TALK= 0 ,REMOTE= 0 ",AS
11: if AS="n";1+A
12: rem 717;ent "LISTEN= 1 ,TALK= 0 ,REMOTE= 1 ",AS
13: if AS="n";1+A
14: llc 7
15: lcl 717;ent "LISTEN= 1 ,TALK= 0 ,REMOTE= 0 ",AS
16: if AS="n";1+A
17: wrt 717,"T1";ent "LISTEN= 1 ,TALK= 0 ,REMOTE= 1 ",AS
18: if AS="n";1+A
19: if A=1;prt "REMOTE/LOCAL TEST          FAIL";spc 3;jmp 2
20: prt "REMOTE/LOCAL TEST          PASS";spc 3
21: 0+A
22: prt "LISTEN/TALK TEST";spc 3
23: red 717,A,B;ent "LISTEN= 0 ,TALK= 1 ,REMOTE= 1 ",AS
24: if AS="n";1+A
25: wrt 717,"T1";ent "LISTEN= 1 ,TALK= 0 ,REMOTE= 1 ",AS
26: if AS="n";1+A
27: if A=1;prt "LISTEN/TALK TEST          FAIL";spc 3;jmp 2
28: prt "LISTEN/TALK TEST          PASS";spc 3
29: prt "END";spc 3
30: cli 7
31: lcl 7
32: end
*32472

```

- (3) Clears 4274A SRO Status Byte.
- (5) Sets REN (Remote Enable) line of the bus line to "1". Switches selected devices (Interface Select Code 7) to remote operation allowing parameters and device characteristics to be controlled by data message.
- (6) Addresses 9825A to talk and 4274A to listen.
- (8) Sets IFC (Interface Clear) line of the bus line to "1". Unconditionally causes control to pass back to 9825A (independent of the device currently in control) and stops all communication.
- (10) Sets REN to "0". Removes all devices (Interface Select Code 7) from local lockout mode and causes all devices to revert to local.
- (12) Sets REN to "1". Switches 4274A to remote operation.
- (14) Prevents the device operator from switching the unit to manual control.
- (15) Causes 4274A to revert to manual control for future parameter modifications (REN remains at "1").
- (17) Returns to the status of Step 14.
- (23) Disables listen address by talk address.
- (25) Disables talk address by listen address.

**PERFORMANCE TESTS**

Table 4-10. Controller Instructions and Operator Responses for Test Program 1.

Controller Instructions		Operator Response
Displays	Printout	
	REMOTE/LOCAL TEST	
LISTEN = 1, TALK = 0, REMOTE = 1		If 4274A HP-IB Status Indicators and Controller Display are same, press "Y", [CONTINUE] " in each step. If not, press "N", [CONTINUE] ".
LISTEN = 0, TALK = 0, REMOTE = 1		
LISTEN = 0, TALK = 0, REMOTE = 0		
LISTEN = 1, TALK = 0, REMOTE = 1		
LISTEN = 1, TALK = 0, REMOTE = 0		
LISTEN = 1, TALK = 0, REMOTE = 1		
	REMOTE/LOCAL TEST PASS	If all steps are correct, this message is outputted.
	REMOTE/LOCAL TEST FAIL	If any step fails, this message is outputted.
	LISTEN/TALK TEST	
LISTEN = 0, TALK = 1, REMOTE = 1		If 4274A HP-IB Status Indicators and Controller Display are same, press "Y", [CONTINUE] " in each step. If not, press "N", [CONTINUE] ".
LISTEN = 1, TALK = 0, REMOTE = 1		
	LISTEN/TALK TEST PASS	If both steps are correct, this message is outputted.
	LISTEN/TALK TEST FAIL	If any step fails, this message is outputted.
	END	

**PERFORMANCE TESTS**

**TEST PROGRAM 2**

**[PURPOSE]**

This test verifies that 4274A Opt. 101 has following capabilities:

- (1) Listener.
- (2) Device Clear.

**[PROGRAMMING]**

```

0: "LISTENER TEST":
1: dim AS(50),DS(1)
2: prt "LISTENER TEST";spc 3
3: rem 7
4: cli 7
5: enp "Display A ? (1 thru 4)",A;spc 3
6: enp "Display B ? (1 thru 3)",B;spc 3
7: enp "Circuit Mode ? (1 thru 3)",C;spc 3
8: enp "Deviation Meas ? (0 thru 2)",D;spc 3
9: enp "Frequency Step ? (1 thru 23)",F;spc 3
10: enp "High Resolution ? (0 or 1)",H;spc 3
11: enp "Data Ready ? (0 or 1)",I;spc 3
12: enp "Multiplier ? (1 thru 4)",M;spc 3
13: enp "LCRZ Range ? (11 thru 23,31,32)",R;spc 3
14: enp "Self Test ? (0 or 1)",S;spc 3
15: enp "Trigger ? (1 thru 3)",T;spc 3
16: fmt 1,"A",f1.0,"B",f1.0,"C",f1.0,"D",f1.0,"F",f2.0,"H",f1.0,"I",f1.0
17: fmt 2,"M",f1.0,"R",f2.0,"S",f1.0,"T",f1.0
18: wrt 717,"ST"
19: wrt 717.1,A,B,C,D,F,H,I
20: wrt 717.2,M,R,S,T
21: gsb "K"
22: ent "Is key status true ? (y or n)",BS
23: if BS="n";prt "LISTENER TEST          FAIL";spc 3;jmp 2
24: prt "LISTENER TEST          PASS";spc 3
25: prt "DEVICE CLEAR TEST";spc 3
26: clr 717
27: gsb "K"
28: ent "Is key status true ? (y or n)",BS
29: if BS="n";prt "DEVICE CLEAR TEST          FAIL";spc 3;jmp 2
30: prt "DEVICE CLEAR TEST          PASS";spc 3
31: prt "END";spc 3
32: end
33: "X":
34: wrt 717,"X"
35: red 717,AS
36: prt AS;spc 3
37: ret
*131d3
    
```

- (18) ~ (20) Transfers remote program codes from 9825A to 4274A.
- (26) Initializes device-dependent functions to predefined state.
- (35) Transfers outputted data from 4274A to 9825A.

Table 4-11. Controller Instructions and Operator Responses for Test Program 2.

Controller Instructions		Operator Response
Displays	Printout	
	LISTENER TEST	
Display A ? (1 thru 4)	Display A ? (1 thru 4) 1	Input HP-IB program code suffix in each step (see Table 3-11).  Example: A1 B3 C3 D2 F22 H1 I0 M3 R20 S0 T3
Display B ? (1 thru 3)	Display B ? (1 thru 3) 3	
Circuit Mode ? (1 thru 3)	Circuit Mode ? (1 thru 3) 3	
Deviation Meas ? (0 thru 2)	Deviation Meas ? (0 thru 2)	

**PERFORMANCE TESTS**

Table 4-11. Controller Instructions and Operator Responses for Test Program 2 (Cont'd).

Controller Instructions		Operator Response
Displays	Printout	
	2	
Frequency Step ? (11 thru 23)	Frequency Step ? (11 thru 23)	A1 ..... L B3 ..... ESR/G C3 .....  D2 ..... Δ% F18 ..... 10kHz H1 ..... ON I0 ..... OFF M3 ..... x1 R15 ..... 1000μH S0 ..... OFF T3 ..... HOLD/MANUAL
	18	
High Resolution ? (0 or 1)	High Resolution ? (0 or 1)	
	1	
Data Ready ? (0 or 1)	Data Ready ? (0 or 1)	
	0	
Multiplier ? (1 thru 4)	Multiplier ? (1 thru 4)	
	3	
LCRZ Range ? (11 thru 23,31,32)	LCRZ Range ? (11 thru 23,31,32)	
	15	
Self Test ? (0 or 1)	Self Test ? (0 o r 1)	
	0	
Trigger ? (1 thru 3)	Trigger ? (1 thr u 3)	
	3	
	A1B3C3D2F18H1I0 M3R15S0T3	This is the key status data of 4274A when it accepts input remote program codes from con- troller.
Is key status true? (y or n)	LISTENER TEST PASS LISTENER TEST FAIL	If input remote program codes and outputted key status data are same, press " <input type="checkbox"/> ", <input type="checkbox"/> "CONTINUE" ". If not, press " <input type="checkbox"/> ", <input type="checkbox"/> "CONTINUE" ".
	DEVICE CLEAR TES T	
	A2B1C1D0F15H0I0 M3R31S0T1	This is the key status data of 4274A when it accepts SDC (Se- lected Device Clear) command from controller.
Is key status true? (y or n)	DEVICE CLEAR TES T PASS DEVICE CLEAR TES T FAIL	If outputted key status data and initial control settings (A2 B1 C1 D0 F17 H0 I0 M3 R31 S0 T1) are same, press " <input type="checkbox"/> ", <input type="checkbox"/> "CONTINUE" ". If not, press " <input type="checkbox"/> ", <input type="checkbox"/> "CONTINUE" ".
	END	

**PERFORMANCE TESTS**

**TEST PROGRAM 3**

[PURPOSE]

This test verifies that 4274A Opt. 101 has following capabilities:

- (1) Talker.
- (2) Device Trigger.

[PROGRAMMING]

```

0: "TALKER TEST":
1: prt "TALKER TEST";spc 3
2: dsp "Connect a capacitor to 16047A.";stp
3: prt "DATA OUTPUT TEST"
4: dim AS[50],BS[50],CS[50],DS[50],ES[50],FS[1]
5: rds(717)+C
6: lcl 7
7: flt 5
8: rem 7
9: cli 7
10: clr 717
11: wrt 717,"T3E"
12: red 717,A,B
13: prt A,B;spc 2
14: ent "Is output data true ? (y or n)",FS[1]
15: if FS="n";prt "DATA OUTPUT TEST . FAIL";spc 3;jmp 2
16: prt "DATA OUTPUT TEST PASS";spc 3
17: prt "COMPLETE DATA OUTPUT TEST"
18: wrt 717,"E"
19: red 717,AS
20: prt AS;spc 2
21: ent "Is output data true ? (y or n)",FS[1]
22: if FS="n";prt "COMPLETE DATA OUTPUT TEST FAIL";spc 3;jmp 2
23: prt "COMPLETE DATA OUTPUT TEST PASS";spc 3
24: prt "DEVICE TRIGGER TEST"
25: trg 717
26: red 717,BS
27: prt BS;spc 2
28: ent "Is output data true ? (y or n)",FS[1]
29: if FS="n";prt "DEVICE TRIGGER TEST FAIL";spc 3;jmp 2
30: prt "DEVICE TRIGGER TEST PASS";spc 3
31: prt "REFERENCE VALUE TEST"
32: wrt 717,"S"
33: wrt 717,"RE"
34: red 717,CS
35: prt CS;spc 2
36: ent "Is output data true ? (y or n)",FS[1]
37: if FS="n";prt "REFERENCE VALUE TEST FAIL";spc 3;jmp 2
38: prt "REFERENCE VALUE TEST PASS";spc 3
39: prt "TEST SIG LEVEL CHECK TEST"
40: wrt 717,"LV"
41: red 717,DS
42: prt DS;spc 1
43: wrt 717,"LA"
44: red 717,ES
45: prt ES;spc 2
46: ent "Is output data true ? (y or n)",FS[1]
47: if FS="n";prt "TEST SIG LEVEL CHECK TEST FAIL";spc 3;jmp 2
48: prt "TEST SIG LEVEL CHECK TEST PASS";spc 3
49: prt "END";spc 3
50: end
*9000
    
```

(25) Causes 4274A to simultaneously initiate a device-dependent action.

Table 4-12. Controller Instructions and Operator Responses for Test Program 3.

Controller Instructions		Operator Response
Displays	Printout	
	TALKER TEST	
Connect a capacitor to 16047A		Connect a capacitor (1000pF~1000nF) to 16047A Test Fixture. Press " <u>CONTINUE</u> ".
	DATA OUTPUT TEST	
	2.74300e-09 5.00000e-04	

**PERFORMANCE TESTS**

Table 4-12. Controller Instructions and Operator Responses for Test Program 3 (Cont'd).

Controller Instructions		Operator Response
Displays	Printout	
Is output data true? (y or n)	DATA OUTPUT TEST PASS	If outputted data and values of DISPLAY A and B are same, press "y", <b>CONTINUE</b> ". If not, press "n", <b>CONTINUE</b> ".
	DATA OUTPUT TEST FAIL	
	COMPLETE DATA OUTPUT TEST	
	PLNC+0.27440E-08,ND+0.00040E+00	
Is output data true? (y or n)	COMPLETE DATA OUTPUT TEST PASS	If outputted data is true, press "y", <b>CONTINUE</b> " (see paragraph 3-82). If not, press "n", <b>CONTINUE</b> ".
	COMPLETE DATA OUTPUT TEST FAIL	
	DEVICE TRIGGER TEST	
	PLNC+0.27430E-08,ND+0.00030E+00	
Is output data true? (y or n)	DEVICE TRIGGER TEST PASS	If outputted data is true, press "y", <b>CONTINUE</b> " (see paragraph 3-82). If not, press "n", <b>CONTINUE</b> ".
	DEVICE TRIGGER TEST FAIL	
	REFERENCE VALUE TEST	
	C+0.27430E-08	Press RECALL key on 4274A front panel and read stored reference value.
Is output data true? (y or n)	REFERENCE VALUE TEST PASS	If outputted data is true, press "y", <b>CONTINUE</b> " (see paragraph 3-84). If not, press "n", <b>CONTINUE</b> ".
	REFERENCE VALUE TEST FAIL	
	TEST SIG LEVEL CHECK TEST	
	NV+1.03E+00 NR+0.17E-04	Press TEST SIG LEVEL CHECK keys on 4274A front panel and read test signal level.
Is output data true? (y or n)	TEST SIG LEVEL CHECK TEST PASS	If outputted data is true, press "y", <b>CONTINUE</b> " (see paragraph 3-86). If not, press "n", <b>CONTINUE</b> ".
	TEST SIG LEVEL CHECK TEST FAIL	
	END	

---

**PERFORMANCE TESTS**

---

## TEST PROGRAM 4

## [PURPOSE]

This test program verifies that 4274A Opt. 101 has following capabilities:

- (1) Service Request.
- (2) Serial Poll.

## [PROGRAMMING]

```

0: "SRQ TEST":
1: prt "SRQ TEST";spc 3
2: fxd 0
3: oni 7,"SRQ"
4: rem 7
5: cli 7
6: clr 717
7: rds(717)+A
8: 0+A;prt "DATA READY";wrt 717,"ILT3E";gsb "LOOP"
9: 0+A;prt "SELF TEST -PASS";wrt 717,"IOS1";gsb "LOOP"
10: 0+A;prt "SELF TEST -FAIL";wrt 717,"A1";gsb "LOOP"
11: 0+A;prt "ZERO OFFSET -PASS";wrt 717,"S020";gsb "LOOP"
12: 0+A;prt "ZERO OFFSET -FAIL(Err1)";wrt 717,"ZS";gsb "LOOP"
13: 0+A;prt "Err5";wrt 717,"T1";wait 9000
14: wrt 717,"ST";gsb "LOOP"
15: 0+A;prt "SYNTAX ERROR";wrt 717,"A5";gsb "LOOP"
16: prt "END";spc 3
17: end
18: "LOOP":eir 7,128
19: if bit(0,A)=1;prt A;spc 3;ret
20: if bit(1,A)=1;prt A;spc 3;ret
21: if bit(2,A)=1;prt A;spc 3;ret
22: if bit(3,A)=1;prt A;spc 3;ret
23: gto "LOOP"
24: "SRQ":rds(717)+A
25: if bit(6,A)=1;jmp 2
26: prt "OTHER DEVICE SRQ";spc 3
27: "IRET":eir 7,128
28: iret
*13153

```

- (3) Designates label (SRQ) for service routing to be performed when an interrupt is set by a device on select code 7 bus line.
- (18) Labels loop. Enables Service Request to be sent from device on select code 7 Bus Line. Checks status of SRQ line on the bus line.
- (27) Again enables acceptance of SRQ from device because SRQ is disabled when Status Byte signal transfer is completed.
- (28) After service subroutine is completed, return to the step that follows step 7, 8 or 9 (as appropriate) to main programming sequence.



**PERFORMANCE TESTS**

Table 4-13. Controller Instructions and Operator Responses for Test Program 4.

Controller Instructions (Printout)	Operator Response
SRQ TEST	
DATA READY	Outputted SRQ Status Byte data should be 65 (= 01000001).
65	
SELF TEST -PASS	Outputted SRQ Status Byte data should be 68 (= 01000100).
68	
SELF TEST -FAIL	Outputted SRQ Status Byte data should be 76 (= 01001100).
76	
ZERO OFFSET -PAS S	Outputted SRQ Status Byte data should be 68 (= 01000100).
68	
ZERO OFFSET -FAI L(Err1)	Outputted SRQ Status Byte data should be 76 (= 01001100).
76	
Err5	Outputted SRQ Status Byte data should be 72 (= 01001000).
72	
SYNTAX ERROR	Outputted SRQ Status Byte data should be 66 (= 01000010).
66	
END	

Performance Test Record

Hewlett-Packard  
 Model 4274A  
 Multi Frequency LCR METER  
 Serial No. \_\_\_\_\_

Tested by \_\_\_\_\_  
 Date \_\_\_\_\_

Paragraph Number	TEST	Results		
		Minimum	Actual	Maximum
4-9	TEST FREQUENCY ACCURACY TEST			
	100Hz	99.99Hz	_____	100.01Hz
	120Hz	119.99Hz	_____	120.01Hz
	200Hz	199.98Hz	_____	200.02Hz
	400Hz	399.96Hz	_____	400.04Hz
	1000Hz	999.9Hz	_____	1000.1Hz
	2.00kHz	1.9998kHz	_____	2.0002kHz
	4.00kHz	3.9996kHz	_____	4.0004kHz
	10.0kHz	9.999kHz	_____	10.001kHz
	20.0kHz	19.998kHz	_____	20.002kHz
	40.0kHz	39.996kHz	_____	40.004kHz
	100kHz	99.99kHz	_____	100.01kHz
	Opt. freq.		_____	
	Opt. freq.		_____	
	4-11	TEST SIGNAL LEVEL TEST		
OSC LEVEL: Fully cw		V rms		
MULTIPLIER: x5				
100Hz		5.00	_____	
120Hz		5.00	_____	
200Hz		5.00	_____	
400Hz		5.00	_____	
1.00kHz		5.00	_____	
2.00kHz		5.00	_____	
4.00kHz		5.00	_____	
10.0kHz		5.00	_____	
20.0kHz		5.00	_____	
40.0kHz		5.00	_____	
100kHz		5.00	_____	
Opt. freq.			_____	
Opt. freq.			_____	
OSC LEVEL: Fully cw		V rms		
MULTIPLIER: x1				
100Hz		1.00	_____	
120Hz		1.00	_____	
200Hz		1.00	_____	
400Hz		1.00	_____	
1.00kHz		1.00	_____	
2.00kHz		1.00	_____	
4.00kHz		1.00	_____	
10.0kHz		1.00	_____	
20.0kHz		1.00	_____	
40.0kHz		1.00	_____	
100kHz		1.00	_____	
Opt. freq.			_____	
Opt. freq.		_____		
OSC LEVEL: Fully cw	mV rms			
MULTIPLIER: x0.1				
100Hz	100	_____		
120Hz	100	_____		

Paragraph Number	TEST	Results		
		Minimum	Actual	Maximum
4-11	TEST SIGNAL LEVEL TEST (Continued)			
	OSC LEVEL: Fully cw MULTIPLIER: x0.1	mV rms		
	200Hz 100 400Hz 100 1.00kHz 100 2.00kHz 100 4.00kHz 100 10.0kHz 100 20.0kHz 100 40.0kHz 100 100kHz 100 Opt. freq. Opt. freq.			
4-11	OSC LEVEL: Fully cw MULTIPLIER: x0.01	mV rms		
	100Hz 10.0 120Hz 10.0 200Hz 10.0 400Hz 10.0 1.00kHz 10.0 2.00kHz 10.0 4.00kHz 10.0 10.0kHz 10.0 20.0kHz 10.0 40.0kHz 10.0 100kHz 10.0 Opt. freq. Opt. freq.			
	OSC LEVEL: Fully ccw MULTIPLIER: x0.01			mV rms
4-11				1.00 1.00 1.00 1.00 1.00 1.00 1.00 1.00 1.00 1.00 1.00 1.00 1.00 1.00 1.00 1.00 1.00 1.00 1.00
	4-13	SELF-OPERATING TEST		
	Step 1. DISPLAY A. 1kHz DISPLAY B. 1kHz	-1.60 -1.60		1.60 1.60
Step 2. DISPLAY A. 1kHz DISPLAY B. 100kHz	998.40 -1.60		1001.60 1.60	
Step 3. DISPLAY A. 1kHz DISPLAY B. 100kHz	998.40 -1.60		1001.60 1.60	
Step 4. DISPLAY A. 1kHz DISPLAY B. 100kHz	998.40 -1.60		1001.60 1.60	

Paragraph Number	TEST	Results		
		Mimumum	Actual	Maximum
4-13	SELF OPERATING TEST (Continued)			
	STEP 5. DISPLAY A. 1kHz	998.40	_____	1001.60
	DISPLAY B. 100kHz	-1.60	_____	1.60
	Step 7. DISPLAY A. 10kHz	-1.60	_____	1.60
	DISPLAY B. 100kHz	-5.00	_____	5.00
	DISPLAY B. 40kHz	-5.00	_____	5.00
4-15	CAPACITANCE ACCURACY TEST			
	1000fF Range. MULTIPLIER: x5			
	Capacitance. PRL 40kHz	C V -4.6fF	_____	C V +4.6fF
	100kHz	C V -4.3fF	_____	C V +4.3fF
	SER 40kHz	C V -4.3fF	_____	C V +4.3fF
	Opt. freq. ( )		_____	
	( )		_____	
	Dissipation. PRL 40kHz	0 -.00230	_____	0 +.00230
	100kHz	0 -.00170	_____	0 +.00170
	SER 40kHz	0 -.00230	_____	0 +.00230
	Opt. freq. ( )		_____	
	( )		_____	
	1000fF Range. MULTIPLIER: x1			
	Capacitance. PRL 40kHz	C V -10.0fF	_____	C V +10.0fF
	100kHz	C V -7.0fF	_____	C V +7.0fF
	Opt. freq. ( )		_____	
	( )		_____	
	Dissipation. PRL 40kHz	0 -.00320	_____	0 +.00320
	100kHz	0 -.00260	_____	0 +.00260
	Opt. freq. ( )		_____	
	( )		_____	
	1000fF Range. MULTIPLIER: x0.1			
	Capacitance. PRL 40kHz	C V -64.0fF	_____	C V +64.0fF
	100kHz	C V -34.0fF	_____	C V +34.0fF
Opt. freq. ( )		_____		
( )		_____		
Dissipation. PRL 40kHz	0 -.01220	_____	0 +.01220	
100kHz	0 -.01160	_____	0 +.01160	
Opt. freq. ( )		_____		
( )		_____		
10pF Range. MULTIPLIER: x5				
Capacitance. PRL 4kHz	C V -.016pF	_____	C V +.016pF	
10kHz	C V -.013pF	_____	C V +.013pF	
20kHz	C V -.012pF	_____	C V +.012pF	
40kHz	C V -.037pF	_____	C V +.037pF	
100kHz	C V -.034pF	_____	C V +.034pF	

\*C V = Calibrated Value

Paragraph Number	TEST	Results		
		Minimum	Actual	Maximum
4-15	CAPACITANCE ACCURACY TEST (Continued)			
	SER 4kHz	C V -.016pF	_____	C V +.016pF
	Opt. freq. ( )		_____	
			_____	
	Dissipation. PRL 4kHz	0 -.00120	_____	0 +.00120
	10kHz	0 -.00090	_____	0 +.00090
	20kHz	0 -.00075	_____	0 +.00075
	40kHz	0 -.00230	_____	0 +.00230
	100kHz	0 -.00170	_____	0 +.00170
	SER 4kHz	0 -.00120	_____	0 +.00120
	Opt. freq. ( )		_____	
			_____	
	10pF Range. MULTIPLIER: x1			
	Capacitance. PRL 4kHz	C V -.070pF	_____	C V +.070pF
	10kHz	C V -.040pF	_____	C V +.040pF
	20kHz	C V -.030pF	_____	C V +.030pF
	40kHz	C V -.037pF	_____	C V +.037pF
	100kHz	C V -.034pF	_____	C V +.034pF
	Opt. freq. ( )		_____	
			_____	
	Dissipation. PRL 4kHz	0 -.00210	_____	0 +.00210
	10kHz	0 -.00180	_____	0 +.00180
	20kHz	0 -.00165	_____	0 +.00165
	40kHz	0 -.00230	_____	0 +.00230
	100kHz	0 -.00170	_____	0 +.00170
	Opt. freq. ( )		_____	
			_____	
	10pF Range. MULTIPLIER: x0.1			
	Capacitance. PRL 4kHz	C V -.610pF	_____	C V +.610pF
	10kHz	C V -.310pF	_____	C V +.310pF
	20kHz	C V -.310pF	_____	C V +.310pF
	40kHz	C V -.091pF	_____	C V +.091pF
	100kHz	C V -.061pF	_____	C V +.061pF
	Opt. freq. ( )		_____	
			_____	
	Dissipation. PRL 4kHz	0 -.01110	_____	0 +.01110
	10kHz	0 -.01080	_____	0 +.01080
	20kHz	0 -.01065	_____	0 +.01065
	40kHz	0 -.00320	_____	0 +.00320
	100kHz	0 -.00260	_____	0 +.00260
	Opt. freq. ( )		_____	
			_____	
	100pF Range. MULTIPLIER: x5			
	Capacitance. PRL 400Hz	C V -.16pF	_____	C V +.16pF
	1kHz	C V -.13pF	_____	C V +.13pF
2kHz	C V -.12pF	_____	C V +.12pF	
4kHz	C V -.16pF	_____	C V +.16pF	
10kHz	C V -.13pF	_____	C V +.13pF	

\*C V = Calibrated Value

Paragraph Number	TEST	Results			
		Minimum	Actual	Maximum	
4-15	CAPACITANCE ACCURACY TEST (Continued)				
		20kHz	C V -.12pF	_____	C V +.12pF
		40kHz	C V -.16pF	_____	C V +.16pF
		100kHz	C V -.13pF	_____	C V +.13pF
		SER 1kHz	C V -.16pF	_____	C V +.16pF
		Opt. freq. ( )		_____	
				_____	
		Dissipation. PRL 400Hz	0 -.00120	_____	0 +.00120
		1kHz	0 -.00090	_____	0 +.00090
		2kHz	0 -.00075	_____	0 +.00075
		4kHz	0 -.00120	_____	0 +.00120
		10kHz	0 -.00090	_____	0 +.00090
		20kHz	0 -.00075	_____	0 +.00075
		40kHz	0 -.00120	_____	0 +.00120
		100kHz	0 -.00090	_____	0 +.00090
		SER 1kHz	0 -.00090	_____	0 +.00090
		Opt. freq. ( )		_____	
				_____	
		100pF Range. MULTIPLIER: x1			
		Capacitance. PRL 400Hz	C V -.70pF	_____	C V +.70pF
		1kHz	C V -.40pF	_____	C V +.40pF
		2kHz	C V -.30pF	_____	C V +.30pF
		4kHz	C V -.16pF	_____	C V +.16pF
		10kHz	C V -.13pF	_____	C V +.13pF
		20kHz	C V -.12pF	_____	C V +.12pF
		40kHz	C V -.16pF	_____	C V +.16pF
		100kHz	C V -.13pF	_____	C V +.13pF
		Opt. freq. ( )		_____	
				_____	
		Dissipation. PRL 400Hz	0 -.00210	_____	0 +.00210
		1kHz	0 -.00180	_____	0 +.00180
		2kHz	0 -.00165	_____	0 +.00165
		4kHz	0 -.00120	_____	0 +.00120
		10kHz	0 -.00090	_____	0 +.00090
		20kHz	0 -.00075	_____	0 +.00075
		40kHz	0 -.00120	_____	0 +.00120
		100kHz	0 -.00090	_____	0 +.00090
		Opt. freq. ( )		_____	
				_____	
		100pF Range MULTIPLIER: x0.1			
		Capacitance. PRL 400Hz	C V -6.10pF	_____	C V +6.10pF
		1kHz	C V -3.10pF	_____	C V +3.10pF
		2kHz	C V -2.10pF	_____	C V +2.10pF
		4kHz	C V -.70pF	_____	C V +.70pF
		10kHz	C V -.40pF	_____	C V +.40pF
	20kHz	C V -.30pF	_____	C V +.30pF	
	40kHz	C V -.16pF	_____	C V +.16pF	
	100kHz	C V -.13pF	_____	C V +.13pF	
	Opt. freq. ( )		_____		
			_____		

\*C V = Calibrated Value

Paragraph Number	TEST	Results		
		Minimum	Actual	Maximum
4-15	CAPACITANCE ACCURACY TEST (Continued)			
	Dissipation. PRL	400Hz	0 -.01110	0 +.01110
		1kHz	0 -.01080	0 +.01080
		2kHz	0 -.01065	0 +.01065
		4kHz	0 -.00210	0 +.00210
		10kHz	0 -.00180	0 +.00180
		20kHz	0 -.00165	0 +.00165
		40kHz	0 -.00120	0 +.00120
		100kHz	0 -.00090	0 +.00090
		Opt. freq. ( )		
		1000pF Range. MULTIPLIER: x5		
	Capacitance. PRL	100Hz	C V -1.3pF	C V +1.3pF
		120Hz	C V -1.3pF	C V +1.3pF
		200Hz	C V -1.2pF	C V +1.2pF
		400Hz	C V -1.6pF	C V +1.6pF
		1kHz	C V -1.3pF	C V +1.3pF
		2kHz	C V -1.2pF	C V +1.2pF
		4kHz	C V -1.6pF	C V +1.6pF
		10kHz	C V -1.3pF	C V +1.3pF
		20kHz	C V -1.2pF	C V +1.2pF
		40kHz	C V -1.6pF	C V +1.6pF
		100kHz	C V -1.3pF	C V +1.3pF
		SER 1kHz	C V -1.3pF	C V +1.3pF
		Opt. freq. ( )		
	Dissipation. PRL	100Hz	0 -.00090	0 +.00090
		120Hz	0 -.00085	0 +.00085
		200Hz	0 -.00075	0 +.00075
		400Hz	0 -.00120	0 +.00120
		1kHz	0 -.00090	0 +.00090
		2kHz	0 -.00075	0 +.00075
		4kHz	0 -.00120	0 +.00120
		10kHz	0 -.00090	0 +.00090
		20kHz	0 -.00075	0 +.00075
		40kHz	0 -.00120	0 +.00120
		100kHz	0 -.00090	0 +.00090
		SER 1kHz	0 -.00090	0 +.00090
		Opt. freq. ( )		
		1000pF Range. MULTIPLIER: x1		
	Capacitance. PRL	100Hz	C V -4.0pF	C V +4.0pF
		120Hz	C V -4.0pF	C V +4.0pF
		200Hz	C V -3.0pF	C V +3.0pF
		400Hz	C V -1.6pF	C V +1.6pF
		1kHz	C V -1.3pF	C V +1.3pF
		2kHz	C V -1.2pF	C V +1.2pF
		4kHz	C V -1.6pF	C V +1.6pF
		10kHz	C V -1.3pF	C V +1.3pF
		20kHz	C V -1.2pF	C V +1.2pF
	40kHz	C V -1.6pF	C V +1.6pF	

i \*C V = Calibrated Value

Paragraph Number	TEST	Results		
		Minimum	Actual	Maximum
4-15	CAPACITANCE/ ACCURACY TEST (Continued)			
	Opt. freq.	100kHz ( ) ( )	C V -1.3pF	C V +1.3pF
	Dissipation. PRL	100Hz	0 -.00180	0 +.00180
		120Hz	0 -.00175	0 +.00175
		200Hz	0 -.00165	0 +.00165
		400Hz	0 -.00120	0 +.00120
		1kHz	0 -.00090	0 +.00090
		2kHz	0 -.00075	0 +.00075
		4kHz	0 -.00120	0 +.00120
		10kHz	0 -.00090	0 +.00090
		20kHz	0 -.00075	0 +.00075
		40kHz	0 -.00120	0 +.00120
		100kHz	0 -.00090	0 +.00090
	Opt. freq.	( ) ( )		
	1000pF Range. MULTIPLIER: x0.1			
	Capacitance. PRL	100Hz	C V -31pF	C V +31pF
		120Hz	C V -31pF	C V +31pF
		200Hz	C V -21pF	C V +21pF
		400Hz	C V -7.0pF	C V +7.0pF
		1kHz	C V -4.0pF	C V +4.0pF
		2kHz	C V -3.0pF	C V +3.0pF
		4kHz	C V -1.6pF	C V +1.6pF
		10kHz	C V -1.3pF	C V +1.3pF
		20kHz	C V -1.2pF	C V +1.2pF
		40kHz	C V -1.6pF	C V +1.6pF
		100kHz	C V -1.3pF	C V +1.3pF
	Opt. freq.	( ) ( )		
	Dissipation. PRL	100Hz	0 -.01080	0 +.01080
		120Hz	0 -.01075	0 +.01075
		200Hz	0 -.01065	0 +.01065
		400Hz	0 -.00210	0 +.00210
		1kHz	0 -.00180	0 +.00180
		2kHz	0 -.00165	0 +.00165
		4kHz	0 -.00120	0 +.00120
		10kHz	0 -.00090	0 +.00090
		20kHz	0 -.00075	0 +.00075
		40kHz	0 -.00120	0 +.00120
		100kHz	0 -.00090	0 +.00090
	Opt. freq.	( ) ( )		

\*C V = Calibrated Value



Paragraph Number	TEST	Results		
		Minimum	Actual	Maximum
4-17	RESISTANCE ACCURACY TEST			
	100Ω Range. MULTIPLIER: x5			
	100Hz	C V -.13Ω	_____	C V +.13Ω
	120Hz	C V -.13Ω	_____	C V +.13Ω
	200Hz	C V -.13Ω	_____	C V +.13Ω
	400Hz	C V -.13Ω	_____	C V +.13Ω
	1kHz	C V -.13Ω	_____	C V +.13Ω
	2kHz	C V -.13Ω	_____	C V +.13Ω
	4kHz	C V -.13Ω	_____	C V +.13Ω
	10kHz	C V -.13Ω	_____	C V +.13Ω
	20kHz	C V -.13Ω	_____	C V +.13Ω
	40kHz	C V -.13Ω	_____	C V +.13Ω
	100kHz	C V -.13Ω	_____	C V +.13Ω
	Opt. freq. ( )		_____	
			_____	
	100Ω Range. MULTIPLIER: x1			
	Within test limit at any freq ?	C V -.13Ω	_____	C V +.13Ω
	100Ω Range. MULTIPLIER: x0.1			
	Within test limit at any freq ?	C V -.13Ω	_____	C V +.13Ω
	1000Ω Range. MULTIPLIER: x5			
	100Hz	C V -4.0Ω	_____	C V +4.0Ω
	120Hz	C V -4.0Ω	_____	C V +4.0Ω
	200Hz	C V -4.0Ω	_____	C V +4.0Ω
	400Hz	C V -4.0Ω	_____	C V +4.0Ω
	1kHz	C V -4.0Ω	_____	C V +4.0Ω
	2kHz	C V -4.0Ω	_____	C V +4.0Ω
	4kHz	C V -4.0Ω	_____	C V +4.0Ω
	10kHz	C V -4.0Ω	_____	C V +4.0Ω
	20kHz	C V -4.0Ω	_____	C V +4.0Ω
	40kHz	C V -4.0Ω	_____	C V +4.0Ω
	100kHz	C V -4.0Ω	_____	C V +4.0Ω
	Opt. freq. ( )		_____	
			_____	
	1000Ω Range. MULTIPLIER: x1			
	Within test limit at any freq ?	C V -4.0Ω	_____	C V +4.0Ω
	1000Ω Range. MULTIPLIER: x0.1			
	Within test limit at any freq ?	C V -4.0Ω	_____	C V +4.0Ω

Paragraph Number	TEST	Results		
		Minimum	Actual	Maximum
4-17	RESISTANCE ACCURACY TEST (Continued)			
	10kΩ Range. MULTIPLIER: x5			
	100Hz	C V -40Ω	_____	C V +40Ω
	120Hz	C V -40Ω	_____	C V +40Ω
	200Hz	C V -40Ω	_____	C V +40Ω
	400Hz	C V -40Ω	_____	C V +40Ω
	1kHz	C V -40Ω	_____	C V +40Ω
	2kHz	C V -40Ω	_____	C V +40Ω
	4kHz	C V -40Ω	_____	C V +40Ω
	10kHz	C V -40Ω	_____	C V +40Ω
	20kHz	C V -40Ω	_____	C V +40Ω
	40kHz	C V -40Ω	_____	C V +40Ω
	100kHz	C V -40Ω	_____	C V +40Ω
	Opt. freq. ( )		_____	
			_____	
	10kΩ Range. MULTIPLIER: x1			
	Within test limit at any freq ?	C V -40Ω	_____	C V +40Ω
	10kΩ Range. MULTIPLIER: x0.1			
	Within test limit at any freq ?	C V -40Ω	_____	C V +40Ω
	100kΩ Range. MULTIPLIER: x5			
	100Hz	C V -400Ω	_____	C V +400Ω
	120Hz	C V -400Ω	_____	C V +400Ω
	200Hz	C V -400Ω	_____	C V +400Ω
	400Hz	C V -400Ω	_____	C V +400Ω
	1kHz	C V -400Ω	_____	C V +400Ω
	2kHz	C V -400Ω	_____	C V +400Ω
	4kHz	C V -400Ω	_____	C V +400Ω
	10kHz	C V -400Ω	_____	C V +400Ω
	20kHz	C V -400Ω	_____	C V +400Ω
	40kHz	C V -400Ω	_____	C V +400Ω
	100kHz	C V -400Ω	_____	C V +400Ω
	Opt. freq. ( )		_____	
			_____	
100kΩ Range. MULTIPLIER: x5				
Within test limit at any freq ?	C V -400Ω	_____	C V +400Ω	
100kΩ Range. MULTIPLIER: x0.1				
Within test limit at any freq ?	C V -400Ω	_____	C V +400Ω	

\*C V = Calibrated Value.

Paragraph Number	TEST	Results		
		Minimum	Actual	Maximum
4-19	INDUCTANCE ACCURACY TEST 100μH Range. MULTIPLIER: x5 (C.V = Lm = ) 100kHz	C V -0.23μH	_____	C V +0.23μH
	100mH Range. MULTIPLIER: x5 (C.V = Lm = ) 1kHz	C V -0.40mH	_____	C V +0.40mH
4-21	FREQUENCY-PHASE ACCURACY TEST 1000mΩ Range. 100Hz 120Hz 200Hz 400Hz 1kHz 2kHz 4kHz 10kHz 20kHz 40kHz 100kHz Opt. freq. ( )	0 -1.50mΩ 0 -1.50mΩ 0 -1.50mΩ 0 -1.50mΩ 0 -1.50mΩ 0 -1.50mΩ 0 -1.50mΩ 0 -1.50mΩ 0 -1.50mΩ 0 -1.50mΩ 0 -1.50mΩ 0 -1.50mΩ	_____ _____ _____ _____ _____ _____ _____ _____ _____ _____ _____ _____	0 +1.50mΩ 0 +1.50mΩ 0 +1.50mΩ 0 +1.50mΩ 0 +1.50mΩ 0 +1.50mΩ 0 +1.50mΩ 0 +1.50mΩ 0 +1.50mΩ 0 +1.50mΩ 0 +1.50mΩ 0 +1.50mΩ
	10Ω Range. 100Hz 120Hz 200Hz 400Hz 1kHz 2kHz 4kHz 10kHz 20kHz 40kHz 100kHz Opt. freq. ( )	0 -.0130Ω 0 -.0130Ω 0 -.0130Ω 0 -.0130Ω 0 -.0130Ω 0 -.0130Ω 0 -.0130Ω 0 -.0130Ω 0 -.0130Ω 0 -.0130Ω 0 -.0130Ω 0 -.0130Ω	_____ _____ _____ _____ _____ _____ _____ _____ _____ _____ _____ _____	0 +.0130Ω 0 +.0130Ω 0 +.0130Ω 0 +.0130Ω 0 +.0130Ω 0 +.0130Ω 0 +.0130Ω 0 +.0130Ω 0 +.0130Ω 0 +.0130Ω 0 +.0130Ω 0 +.0130Ω
4-23	INT DC BIAS SUPPLY TEST (OPTION 001 ONLY)	.000V .002V .005V .010V .020V .050V .100V .200V .500V 1.00V 2.00V 5.00V 10.0V	- .0020V .0000V .0030V .0080V .0179V .0478V .0975V .1970V .4955V .9910V 1.986V 4.972V 9.930V	_____ _____ _____ _____ _____ _____ _____ _____ _____ _____ _____ _____ _____

\*C V = Calibrated Value

Paragraph Number	TEST	Results		
		Minimum	Actual	Maximum
4-23	INT DC BIAS SUPPLY TEST (OPTION 001 ONLY) (Continued)			
	20.0V	19.88V	_____	20.12V
	30.0V	29.82V	_____	30.16V
4-25	INT DC BIAS SUPPLY TEST (OPTION 002 ONLY)			
	00.0V	-0.040V	_____	0.040V
	00.2V	0.156V	_____	0.244V
	00.5V	0.450V	_____	0.550V
	01.0V	0.940V	_____	1.060V
	02.0V	1.920V	_____	2.08V
	05.0V	4.86V	_____	5.14V
	10.0V	9.76V	_____	10.24V
	20.0V	19.56V	_____	20.44V
	50.0V	48.97V	_____	51.03V
90.0V	88.18V	_____	91.82V	



Paragraph Number	TEST	Results		
		Minimum	Actual	Maximum
4-11	TEST SIGNAL LEVEL TEST (Continued)			
	OSC LEVEL: Fully cw MULTIPLIER: x0.1	mV rms		
	300Hz 100 500Hz 100 1.00kHz 100 3.00kHz 100 5.00kHz 100 10.0kHz 100 30.0kHz 100 50.0kHz 100 100kHz 100 Opt. freq. Opt. freq.			
4-11	OSC LEVEL: Fully cw MULTIPLIER: x0.01	mV rms		
	100Hz 10.0 120Hz 10.0 300Hz 10.0 500Hz 10.0 1.00kHz 10.0 3.00kHz 10.0 5.00kHz 10.0 10.0kHz 10.0 30.0kHz 10.0 50.0kHz 10.0 100kHz 10.0 Opt. freq. Opt. freq.			
	OSC LEVEL: Fully ccw MULTIPLIER: x0.01			mV rms
4-11				1.00 1.00 1.00 1.00 1.00 1.00 1.00 1.00 1.00 1.00 1.00 1.00 1.00 1.00 1.00
	100Hz 120Hz 300Hz 500Hz 1.00kHz 3.00kHz 5.00kHz 10.0kHz 30.0kHz 50.0kHz 100kHz Opt. freq.			
4-13	SELF-OPERATING TEST			
	Step 1. DISPLAY A. 1kHz DISPLAY B. 1kHz	-1.60 -1.60		1.60 1.60
	Step 2. DISPLAY A. 1kHz DISPLAY B. 100kHz	998.40 -1.60		1001.60 1.60
	Step 3. DISPLAY A. 1kHz DISPLAY B. 100kHz	998.40 -1.60		1001.60 1.60
	Step 4. DISPLAY A. 1kHz DISPLAY B. 100kHz	998.40 -1.60		1001.60 1.60

Paragraph Number	TEST	Results		
		Minimum	Actual	Maximum
4-13	SELF OPERATING TEST (Continued)			
	STEP 5. DISPLAY A. 1kHz	998.40	_____	1001.60
	DISPLAY B. 100kHz	-1.60	_____	1.60
	Step 7. DISPLAY A. 10kHz	-1.60	_____	1.60
	DISPLAY B.	-1.60	_____	1.60
	DISPLAY A. 100kHz	-5.00	_____	5.00
	DISPLAY B.	-5.00	_____	5.00
4-15	CAPACITANCE ACCURACY TEST			
	1000fF Range. MULTIPLIER: x5			
	Capacitance. PRL 30kHz	C V -4.8fF	_____	C V +4.8fF
	50kHz	C V -4.5fF	_____	C V +4.5fF
	100kHz	C V -4.3fF	_____	C V +4.3fF
	SER 30kHz	C V -4.8fF	_____	C V +4.8fF
	Opt. freq. ( )		_____	
	Dissipation. PRL 30kHz	0 -.00130	_____	0 +.00130
	50kHz	0 -.00230	_____	0 +.00230
	100kHz	0 -.00170	_____	0 +.00170
	SER 30kHz	0 -.00130	_____	0 +.00130
	Opt. freq. ( )		_____	
	1000fF Range. MULTIPLIER: x1			
	Capacitance. PRL 30kHz	C V -12.0fF	_____	C V +12.0fF
	50kHz	C V -10.0fF	_____	C V +10.9fF
	100kHz	C V -7.0fF	_____	C V +7.0fF
	Opt. freq. ( )		_____	
	Dissipation. PRL 30kHz	0 -.00220	_____	0 +.00220
	50kHz	0 -.00320	_____	0 +.00320
	100kHz	0 -.00260	_____	0 +.00260
	Opt. freq. ( )		_____	
	1000fF Range. MULTIPLIER: x0.1			
	Capacitance. PRL 30kHz	C V -84.0fF	_____	C V +84.0fF
	50kHz	C V -54.0fF	_____	C V +54.0fF
	100kHz	C V -34.0fF	_____	C V +34.0fF
	Opt. freq. ( )		_____	
	Dissipation. PRL 30kHz	0 -.01120	_____	0 +.01120
	50kHz	0 -.01220	_____	0 +.01220
	100kHz	0 -.01160	_____	0 +.01660
	Opt. freq. ( )		_____	
10pF Range. MULTIPLIER: x5				
Capacitance. PRL 3kHz	C V -.018pF	_____	C V +.018pF	
5kHz	C V -.015pF	_____	C V +.015pF	
10kHz	C V -.013pF	_____	C V +.013pF	
30kHz	C V -.038pF	_____	C V +.038pF	
50kHz	C V -.035pF	_____	C V +.035pF	

\*C V = Calibrated Value

Paragraph Number	TEST	Results		
		Minimum	Actual	Maximum
4-15	CAPACITANCE ACCURACY TEST (Continued)			
	100kHz	C V -.034pF	_____	C V +.034pF
	SER 3kHz	C V -.018pF	_____	C V +.018pF
	Opt. freq. ( )		_____	
	Dissipation. PRL 3kHz	0 -.00160	_____	0 +.00160
	5kHz	0 -.00120	_____	0 +.00120
	10kHz	0 -.00090	_____	0 +.00090
	30kHz	0 -.00130	_____	0 +.00130
	50kHz	0 -.00230	_____	0 +.00230
	100kHz	0 -.00170	_____	0 +.00170
	SER 3kHz	0 -.00160	_____	0 +.00160
	Opt. freq. ( )		_____	
	10pF Range. MULTIPLIER: x1			
	Capacitance. PRL 3kHz	C V -.080pF	_____	C V +.080pF
	5kHz	C V -.060pF	_____	C V +.060pF
	10kHz	C V -.040pF	_____	C V +.040pF
	30kHz	C V -.110pF	_____	C V +.110pF
	50kHz	C V -.080pF	_____	C V +.080pF
	100kHz	C V -.034pF	_____	C V +.034pF
	Opt. freq. ( )		_____	
	Dissipation. PRL 3kHz	0 -.00160	_____	0 +.00160
	5kHz	0 -.00210	_____	0 +.00210
	10kHz	0 -.00180	_____	0 +.00180
	30kHz	0 -.00130	_____	0 +.00130
	50kHz	0 -.00230	_____	0 +.00230
	100kHz	0 -.00170	_____	0 +.00170
	Opt. freq. ( )		_____	
	10pF Range. MULTIPLIER: x0.1			
	Capacitance. PRL 3kHz	C V -.810pF	_____	C V +.810pF
	5kHz	C V -.510pF	_____	C V +.510pF
	10kHz	C V -.310pF	_____	C V +.310pF
	30kHz	C V -.830pF	_____	C V +.830pF
	50kHz	C V -.530pF	_____	C V +.530pF
	100kHz	C V -.061pF	_____	C V +.061pF
	Opt. freq. ( )		_____	
	Dissipation. PRL 3kHz	0 -.01150	_____	0 +.01150
	5kHz	0 -.01110	_____	0 +.01110
	10kHz	0 -.01080	_____	0 +.01080
	30kHz	0 -.00220	_____	0 +.00220
	50kHz	0 -.00320	_____	0 +.00320
	100kHz	0 -.00260	_____	0 +.00260
	Opt. freq. ( )		_____	
	100pF Range. MULTIPLIER: x5			
	Capacitance. PRL 300Hz	C V -.18pF	_____	C V +.18pF
	500Hz	C V -.15pF	_____	C V +.15pF
1kHz	C V -.13pF	_____	C V +.13pF	
3kHz	C V -.18pF	_____	C V +.18pF	
5kHz	C V -.15pF	_____	C V +.15pF	

\*C V = Calibrated Value



Paragraph Number	TEST	Results		
		Minimum	Actual	Maximum
4-15	CAPACITANCE ACCURACY TEST (Continued)			
	10kHz	C V -.13pF	_____	C V +.13pF
	30kHz	C V -.18pF	_____	C V +.18pF
	50kHz	C V -.15pF	_____	C V +.15pF
	100kHz	C V -.13pF	_____	C V +.13pF
	SER 1kHz	C V -.16pF	_____	C V +.16pF
	Opt. freq. ( )		_____	
	Dissipation. PRL 300Hz	0 -.00160	_____	0 +.00160
	500Hz	0 -.00120	_____	0 +.00120
	1kHz	0 -.00090	_____	0 +.00090
	3kHz	0 -.00160	_____	0 +.00160
	5kHz	0 -.00120	_____	0 +.00120
	10kHz	0 -.00090	_____	0 +.00090
	30kHz	0 -.00160	_____	0 +.00160
	50kHz	0 -.00120	_____	0 +.00120
	100kHz	0 -.00090	_____	0 +.00090
	SER 1kHz	0 -.00090	_____	0 +.00090
	Opt. freq. ( )		_____	
	100pF Range. MULTIPLIER: x1			
	Capacitance. PRL 300Hz	C V -.90pF	_____	C V +.90pF
	500Hz	C V -.60pF	_____	C V +.60pF
	1kHz	C V -.40pF	_____	C V +.40pF
	3kHz	C V -.18pF	_____	C V +.18pF
	5kHz	C V -.15pF	_____	C V +.15pF
	10kHz	C V -.13pF	_____	C V +.13pF
	30kHz	C V -.18pF	_____	C V +.18pF
	50kHz	C V -.15pF	_____	C V +.15pF
	100kHz	C V -.13pF	_____	C V +.13pF
	Opt. freq. ( )		_____	
	Dissipation. PRL 300Hz	0 -.00250	_____	0 +.00250
	500Hz	0 -.00210	_____	0 +.00210
	1kHz	0 -.00180	_____	0 +.00180
	3kHz	0 -.00160	_____	0 +.00160
	5kHz	0 -.00120	_____	0 +.00120
	10kHz	0 -.00090	_____	0 +.00090
	30kHz	0 -.00160	_____	0 +.00160
	50kHz	0 -.00120	_____	0 +.00120
	100kHz	0 -.00090	_____	0 +.00090
	Opt. freq. ( )		_____	
	100pF Range MULTIPLIER: x0.1			
	Capacitance. PRL 300Hz	C V -8.10pF	_____	C V +8.10pF
	500Hz	C V -5.10pF	_____	C V +5.10pF
	1kHz	C V -3.10pF	_____	C V +3.10pF
	3kHz	C V -.90pF	_____	C V +.90pF
	5kHz	C V -.60pF	_____	C V +.60pF
	10kHz	C V -.40pF	_____	C V +.40pF
	30kHz	C V -.18pF	_____	C V +.18pF
	50kHz	C V -.15pF	_____	C V +.15pF
	100kHz	C V -.13pF	_____	C V +.13pF
	Opt. freq. ( )		_____	

\*C V = Calibrated Value

Paragraph Number	TEST	Results			
		Minimum	Actual	Maximum	
4-15	CAPACITANCE ACCURACY TEST (Continued)				
	Dissipation. PRL	300Hz	0 -.01150	_____	0 +.01150
		500Hz	0 -.01110	_____	0 +.01110
		1kHz	0 -.01080	_____	0 +.01080
		3kHz	0 -.00250	_____	0 +.00250
		5kHz	0 -.00210	_____	0 +.00210
		10kHz	0 -.00180	_____	0 +.00180
		30kHz	0 -.00160	_____	0 +.00160
		50kHz	0 -.00120	_____	0 +.00120
		100kHz	0 -.00090	_____	0 +.00090
		Opt. freq. ( )		_____	
		1000pF Range. MULTIPLIER: x5			
	Capacitance. PRL	100Hz	C V -1.3pF	_____	C V +1.3pF
		120Hz	C V -1.3pF	_____	C V +1.3pF
		300Hz	C V -1.8pF	_____	C V +1.8pF
		500Hz	C V -1.5pF	_____	C V +1.5pF
		1kHz	C V -1.3pF	_____	C V +1.3pF
		3kHz	C V -1.8pF	_____	C V +1.8pF
		5kHz	C V -1.5pF	_____	C V +1.5pF
		10kHz	C V -1.3pF	_____	C V +1.3pF
		30kHz	C V -1.8pF	_____	C V +1.8pF
		50kHz	C V -1.5pF	_____	C V +1.5pF
		100kHz	C V -1.3pF	_____	C V +1.3pF
		SER 1kHz	C V -1.3pF	_____	C V +1.3pF
		Opt. freq. ( )		_____	
		Opt. freq. ( )		_____	
	Dissipation. PRL	100Hz	0 -.00090	_____	0 +.00090
		120Hz	0 -.00085	_____	0 +.00085
		300Hz	0 -.00160	_____	0 +.00160
		500Hz	0 -.00120	_____	0 +.00120
		1kHz	0 -.00090	_____	0 +.00090
		3kHz	0 -.00160	_____	0 +.00160
		5kHz	0 -.00120	_____	0 +.00120
		10kHz	0 -.00090	_____	0 +.00090
		30kHz	0 -.00160	_____	0 +.00160
		50kHz	0 -.00120	_____	0 +.00120
		100kHz	0 -.00090	_____	0 +.00090
		SER 1kHz	0 -.00090	_____	0 +.00090
		Opt. freq. ( )		_____	
		Opt. freq. ( )		_____	
		1000pF Range. MULTIPLIER: x1			
	Capacitance. PRL	100Hz	C V -4.0pF	_____	C V +4.0pF
		120Hz	C V -4.0pF	_____	C V +4.0pF
		300Hz	C V -1.8pF	_____	C V +1.8pF
		500Hz	C V -1.5pF	_____	C V +1.5pF
	1kHz	C V -1.3pF	_____	C V +1.3pF	
	3kHz	C V -1.8pF	_____	C V +1.8pF	
	5kHz	C V -1.5pF	_____	C V +1.5pF	
	10kHz	C V -1.3pF	_____	C V +1.3pF	
	30kHz	C V -1.8pF	_____	C V +1.8pF	
	50kHz	C V -1.5pF	_____	C V +1.5pF	

i. \*C V = Calibrated Value\*

Paragraph Number	TEST	Results			
		Minimum	Actual	Maximum	
4-15	CAPACITANCE/ ACCURACY TEST (Continued)				
	Opt. freq.	100kHz ( ) ( )	C V -1.3pF _____ _____ _____	C V +1.3pF	
	Dissipation. PRL	100Hz 120Hz 300Hz 500Hz 1kHz 3kHz 5kHz 10kHz 30kHz 50kHz 100kHz	0 -.00180 0 -.00175 0 -.00160 0 -.00210 0 -.00090 0 -.00160 0 -.00120 0 -.00090 0 -.00160 0 -.00120 0 -.00090	0 +.00180 0 +.00175 0 +.00160 0 +.00210 0 +.00090 0 +.00160 0 +.00120 0 +.00090 0 +.00160 0 +.00120 0 +.00090	
	Opt. freq.	( ) ( )	_____ _____		
	1000pF Range. MULTIPLIER: x0.1				
	Capacitance. PRL	100Hz 120Hz 300Hz 500Hz 1kHz 3kHz 5kHz 10kHz 30kHz 50kHz 100kHz	C V -31pF C V -31pF C V -9.0pF C V -6.0pF C V -4.0pF C V -1.8pF C V -1.5pF C V -1.3pF C V -1.8pF C V -1.5pF C V -1.3pF	_____ _____ _____ _____ _____ _____ _____ _____ _____ _____ _____	C V +31pF C V +31pF C V +9.0pF C V +6.0pF C V +4.0pF C V +1.8pF C V +1.5pF C V +1.3pF C V +1.8pF C V +1.5pF C V +1.3pF
	Opt. freq.	( ) ( )	_____ _____		
	Dissipation. PRL	100Hz 120Hz 300Hz 500Hz 1kHz 3kHz 5kHz 10kHz 30kHz 50kHz 100kHz	0 -.01080 0 -.01075 0 -.00250 0 -.00210 0 -.00180 0 -.00160 0 -.00120 0 -.00090 0 -.00160 0 -.00120 0 -.00090	_____ _____ _____ _____ _____ _____ _____ _____ _____ _____ _____	0 +.01080 0 +.01075 0 +.00250 0 +.00210 0 +.00180 0 +.00160 0 +.00120 0 +.00090 0 +.00160 0 +.00120 0 +.00090
	Opt. freq.	( ) ( )	_____ _____		

\*C V = Calibrated Value

Paragraph Number	TEST	Results		
		Minimum	Actual	Maximum
4-17	RESISTANCE ACCURACY TEST			
	100Ω Range. MULTIPLIER: x5			
	100Hz	C V $-.13\Omega$	_____	C V $+.13\Omega$
	120Hz	C V $-.13\Omega$	_____	C V $+.13\Omega$
	300Hz	C V $-.13\Omega$	_____	C V $+.13\Omega$
	500Hz	C V $-.13\Omega$	_____	C V $+.13\Omega$
	1kHz	C V $-.13\Omega$	_____	C V $+.13\Omega$
	3kHz	C V $-.13\Omega$	_____	C V $+.13\Omega$
	5kHz	C V $-.13\Omega$	_____	C V $+.13\Omega$
	10kHz	C V $-.13\Omega$	_____	C V $+.13\Omega$
	30kHz	C V $-.13\Omega$	_____	C V $+.13\Omega$
	50kHz	C V $-.13\Omega$	_____	C V $+.13\Omega$
	100kHz	C V $-.13\Omega$	_____	C V $+.13\Omega$
	Opt. freq. ( )		_____	
	100Ω Range. MULTIPLIER: x1			
	Within test limit at any freq ?	C V $-.13\Omega$	_____	C V $+.13\Omega$
	100Ω Range. MULTIPLIER: x0.1			
	Within test limit at any freq ?	C V $-.13\Omega$	_____	C V $+.13\Omega$
	1000Ω Range. MULTIPLIER: x5			
	100Hz	C V $-4.0\Omega$	_____	C V $+4.0\Omega$
	120Hz	C V $-4.0\Omega$	_____	C V $+4.0\Omega$
	300Hz	C V $-4.0\Omega$	_____	C V $+4.0\Omega$
	500Hz	C V $-4.0\Omega$	_____	C V $+4.0\Omega$
	1kHz	C V $-4.0\Omega$	_____	C V $+4.0\Omega$
	3kHz	C V $-4.0\Omega$	_____	C V $+4.0\Omega$
	5kHz	C V $-4.0\Omega$	_____	C V $+4.0\Omega$
	10kHz	C V $-4.0\Omega$	_____	C V $+4.0\Omega$
	30kHz	C V $-4.0\Omega$	_____	C V $+4.0\Omega$
	50kHz	C V $-4.0\Omega$	_____	C V $+4.0\Omega$
	100kHz	C V $-4.0\Omega$	_____	C V $+4.0\Omega$
	Opt. freq. ( )		_____	
	1000Ω Range. MULTIPLIER: x1			
	Within test limit at any freq.?	C V $-4.0\Omega$	_____	C V $+4.0\Omega$
	1000Ω Range. MULTIPLIER: x0.1			
	Within test limit at any freq.?	C V $-4.0\Omega$	_____	C V $+4.0\Omega$

iii. \*C V = Calibrated Value.

Paragraph Number	TEST	Results		
		Minimum	Actual	Maximum
4-17	RESISTANCE ACCURACY TEST (Continued)			
	10kΩ Range. MULTIPLIER: x5			
	100Hz	C V -40Ω	_____	C V +40Ω
	120Hz	C V -40Ω	_____	C V +40Ω
	300Hz	C V -40Ω	_____	C V +40Ω
	500Hz	C V -40Ω	_____	C V +40Ω
	1kHz	C V -40Ω	_____	C V +40Ω
	3kHz	C V -40Ω	_____	C V +40Ω
	5kHz	C V -40Ω	_____	C V +40Ω
	10kHz	C V -40Ω	_____	C V +40Ω
	30kHz	C V -40Ω	_____	C V +40Ω
	50kHz	C V -40Ω	_____	C V +40Ω
	100kHz	C V -40Ω	_____	C V +40Ω
	Opt. freq. ( )		_____	
			_____	
	10kΩ Range. MULTIPLIER: x1			
	Within test limit at any freq.?	C V -40Ω	_____	C V +40Ω
	10kΩ Range. MULTIPLIER: x0.1			
	Within test limit at any freq.?	C V -40Ω	_____	C V +40Ω
	100kΩ Range. MULTIPLIER: x5			
	100Hz	C V -400Ω	_____	C V +400Ω
	120Hz	C V -400Ω	_____	C V +400Ω
	300Hz	C V -400Ω	_____	C V +400Ω
	500Hz	C V -400Ω	_____	C V +400Ω
	1kHz	C V -400Ω	_____	C V +400Ω
	3kHz	C V -400Ω	_____	C V +400Ω
	5kHz	C V -400Ω	_____	C V +400Ω
	10kHz	C V -400Ω	_____	C V +400Ω
	30kHz	C V -400Ω	_____	C V +400Ω
	50kHz	C V -400Ω	_____	C V +400Ω
	100kHz	C V -400Ω	_____	C V +400Ω
	Opt. freq. ( )		_____	
			_____	
100kΩ Range. MULTIPLIER: x5				
Within test limit at any freq.?	C V -400Ω	_____	C V +400Ω	
100kΩ Range. MULTIPLIER: x0.1				
Within test limit at any freq.?	C V -400Ω	_____	C V +400Ω	

\*C V = Calibrated Value.

Paragraph Number	TEST	Results		
		Minimum	Actual	Maximum
4-19	INDUCTANCE ACCURACY TEST 100μH Range. MULTIPLIER: x5 (C.V = Lm = ) 100kHz	C V -0.23μH	_____	C V +0.23μH
	100mH Range. MULTIPLIER: x5 (C.V = Lm = ) 1kHz	C V -0.40mH	_____	C V +0.40mH
4-21	FREQUENCY-PHASE ACCURACY TEST			
	1000mΩ Range.      100Hz	0 -1.50mΩ	_____	0 +1.50mΩ
	120Hz	0 -1.50mΩ	_____	0 +1.50mΩ
	300Hz	0 -1.50mΩ	_____	0 +1.50mΩ
	500Hz	0 -1.50mΩ	_____	0 +1.50mΩ
	1kHz	0 -1.50mΩ	_____	0 +1.50mΩ
	3kHz	0 -1.50mΩ	_____	0 +1.50mΩ
	5kHz	0 -1.50mΩ	_____	0 +1.50mΩ
	10kHz	0 -1.50mΩ	_____	0 +1.50mΩ
	30kHz	0 -1.50mΩ	_____	0 +1.50mΩ
	50kHz	0 -1.50mΩ	_____	0 +1.50mΩ
	100kHz	0 -1.50mΩ	_____	0 +1.50mΩ
	Opt. freq. (      )			
	10Ω Range.            100Hz	0 -.0130Ω	_____	0 +.0130Ω
	120Hz	0 -.0130Ω	_____	0 +.0130Ω
	300Hz	0 -.0130Ω	_____	0 +.0130Ω
	500Hz	0 -.0130Ω	_____	0 +.0130Ω
	1kHz	0 -.0130Ω	_____	0 +.0130Ω
	3kHz	0 -.0130Ω	_____	0 +.0130Ω
	5kHz	0 -.0130Ω	_____	0 +.0130Ω
	10kHz	0 -.0130Ω	_____	0 +.0130Ω
	30kHz	0 -.0130Ω	_____	0 +.0130Ω
	50kHz	0 -.0130Ω	_____	0 +.0130Ω
	100kHz	0 -.0130Ω	_____	0 +.0130Ω
Opt. freq. (      )				
4-23	INT DC BIAS SUPPLY TEST (OPTION 001 ONLY)			
	.000V	-.0020V	_____	.0020V
	.002V	.0000V	_____	.0040V
	.005V	.0030V	_____	.0070V
	.010V	.0080V	_____	.0120V
	.020V	.0179V	_____	.0221V
	.050V	.0478V	_____	.0522V
	.100V	.0975V	_____	.1025V
	.200V	.1970V	_____	.2030V
	.500V	.4955V	_____	.5045V
	1.00V	.9910V	_____	1.009V
	2.00V	1.986V	_____	2.014V
5.00V	4.972V	_____	5.028V	
10.0V	9.930V	_____	10.07V	

\*C V = Calibrated Value

Paragraph Number	TEST	Results		
		Minimum	Actual	Maximum
4-23	INT DC BIAS SUPPLY TEST (OPTION 001 ONLY) (Continued) 20.0V 30.0V	19.88V 29.82V	_____ _____	20.12V 30.16V
4-25	INT DC BIAS SUPPLY TEST (OPTION 002 ONLY) 00.0V 00.2V 00.5V 01.0V 02.0V 05.0V 10.0V 20.0V 50.0V 90.0V	-0.040V 0.156V 0.450V 0.940V 1.920V 4.86V 9.76V 19.56V 48.97V 88.18V	_____ _____ _____ _____ _____ _____ _____ _____ _____ _____	0.040V 0.244V 0.550V 1.060V 2.08V 5.14V 10.24V 20.44V 51.03V 91.82V

## SECTION V ADJUSTMENT

### 5-1. INTRODUCTION.

5-2. This section provides the information needed to adjust the 4274A to its specifications (listed in Table 1-1). The prime purpose of adjustment is to return the instrument to its peak operating capabilities after repairs have been made. Adjustment procedures can also be periodically performed to maintain top notch performance. Recommended adjustment cycle for the 4274A is once every six months. All adjustable components referred to in individual adjustments are summarized in Table 5-1 and these locations can be identified in Section VIII. If proper performance cannot be achieved after adjustment procedure has been performed, refer to Section VIII Troubleshooting Procedures.

#### Note

Before proceeding to any adjustment, allow a warm up time of more than 30 minutes to stabilize operating conditions.

### 5-3. SAFETY REQUIREMENTS.

5-4. Although the instrument has been designed in accordance with international safety standards, this manual contains information, cautions and warnings which must be followed to ensure safe operation and to keep the instrument in safe condition. Adjustments described in this section should be performed only by qualified service personnel.

#### WARNING

ANY INTERRUPTION OF THE PROTECTIVE (GROUNDED) CONDUCTOR (INSIDE OR OUTSIDE OF THE INSTRUMENT) OR DISCONNECTION OF THE PROTECTIVE EARTH TERMINAL IS LIKELY TO MAKE THE INSTRUMENT DANGEROUS. INTENTIONAL INTERRUPTION IS PROHIBITED.

5-5. The opening of covers for removal of parts, except those to which access can be gained by hand, is likely to expose live parts.

5-6. Capacitors inside instrument may still be charged even if instrument has been disconnected from its source of supply.

#### WARNING

ADJUSTMENTS DESCRIBED HEREIN ARE PERFORMED WITH POWER SUPPLIED TO THE INSTRUMENT AFTER PROTECTIVE COVERS HAVE BEEN REMOVED. ENERGY EXISTING AT MANY POINTS MAY, IF CONTACTED, RESULT IN PERSONAL INJURY.

### 5-7. EQUIPMENT REQUIRED.

5-8. The equipment needed to adjust the Model 4274A is listed in Table 4-1 (page 4-0). This equipment should always be calibrated to satisfy its own specifications and those of the required characteristics. If the recommended model is not available, any instrument that has specifications equal to or better than required specifications may be substituted.

### 5-9. FACTORY SELECTED COMPONENTS.

5-10. Factory selected components can be recognized by an asterisk adjacent to the reference designator on the schematic diagrams in Section VIII (nominal value is shown). Table 5-2 lists all factory selected components with their nominal value ranges and their influence on instrument performance.

5-11. Adjustable components, with reference designators are listed in Table 5-1. The table gives the name of the control to be adjusted and the purpose of its adjustment.

### 5-12. ADJUSTMENT RELATIONSHIPS.

5-13. The adjustment procedures, beginning with paragraph 5-18, should be performed in step sequence as they are interactive. Neglecting or changing procedures may make it impossible to obtain best 4274A performance. Table 5-3 shows necessary adjustment procedures to be used after repair to the instrument.

### 5-14. ADJUSTMENT LOCATIONS.

5-15. For reference, an illustration of overall adjustment locations is given in Figure 8-13. The locations of individual board assemblies are shown in board assembly component location illustrations included with each fold-out service sheet.



Table 5-1. Adjustable Components.

Paragraph	Reference Designator	Name of Control	Purpose
5-18	A11R3	STANDARD REFERENCE VOLTAGE	To set output of reference voltage to $\pm 5.00$ volts.
5-19	A5R3	DC REF	To minimize residual input to integrator and to optimize zero detection.
5-20	A4R1(ADJ4) A4R55(ADJ2) A4R8(ADJ3)	DC OFFSET	To minimize residual DC offset voltage in process amplifier to maximize measurement accuracy.
5-21	A6R3	OSCILLATOR	To obtain appropriate oscillation without any visible distortion or clipping.
5-22	A3R1	POWER AMPLIFIER	To set appropriate amplitude and to ensure that a clean sinusoidal signal is present at UNKNOWN terminals.
5-23	A2R43	90° PHASE SHIFT	To set an accurate 90° phase shift for 90° phase detector to achieve optimum bridge balance.
5-24	A2R1 A2R8	ZERO OFFSET	To eliminate residual offset in phase tracking amplifier (preadjustment).
5-25	A1R1 A1C2	OFFSET	To minimize residual offset in buffer amplifier at all frequencies.
5-26	A2R1 A2R8	ZERO OFFSET	To eliminate residual offset from both phase detector 0° and 90° integrators.
5-27	A4R10(ADJ7) A4C6(ADJ10) A4C7(ADJ9) A4R11(ADJ8)	ATTENUATOR AND GAIN	To set accurate amplifier gains and attenuations for x1, x1/2 and x1/4 amplifiers to maximize measurement accuracy.
5-28	A4R6(ADJ11) A4C4(ADJ14) A4C5(ADJ13) A4R7(ADJ12)	ATTENUATOR AND GAIN	To set accurate amplifier gains and attenuations for x1, x1/10 and x1/100 amplifier to maximize measurement accuracy.
5-29	A3R16	OSC LEVEL MONITOR	To establish a precise indication for test signal level monitoring.
5-30	A1R21(100k $\Omega$ ) A1R18(10k $\Omega$ ) A1R15(1k $\Omega$ ) A1R12(100 $\Omega$ ) A1R8(10 $\Omega$ ) A4R1(ADJ4) A4C3(ADJ5)	RANGE RESISTOR & BUFFER AMP GAIN	To establish precise range resistor resistance to maximize measurement accuracies on each range at 1.00 kHz and to set appropriate gain in range resistor buffer amplifier at 100kHz.
5-31	A1C11(100k $\Omega$ $\phi$ ) A1C10(10k $\Omega$ $\phi$ ) A1C9(1k $\Omega$ $\phi$ ) A1C7(10 $\Omega$ $\phi$ )	RANGE RESISTOR PHASE	To minimize residual phase offset that especially occurs at higher frequencies in the range resistor of bridge circuit to maximize measurement accuracies for all frequencies.

Table 5-2. Factory Selected Components (sheet 1 of 2).

Reference Designator	Nominal Value Range	Effect on Performance
A1C8 (Para. 5-31)	HP P/N: 0140-0198 C: FXD 200pF HP P/N: 0160-0134 C: FXD 220pF HP P/N: 0140-0199 C: FXD 240pF HP P/N: 0140-0210 C: FXD 270pF HP P/N: 0160-2207 C: FXD 300pF HP P/N: 0160-2208 C: FXD 330pF HP P/N: 0160-2209 C: FXD 360pF HP P/N: 0160-0200 C: FXD 390pF HP P/N: 0160-0939 C: FXD 430pF	To minimize dissipation measurement error. Changing the capacitance value of A1C8 by 30pF causes an approximate 10 count change on Display B.
A4C4 (Para. 5-28)	HP P/N: 0121-0059 C: Trim 2/8pF HP P/N: 0121-0036 C: Trim 5.5/18pF	Minimizes dissipation measurement error. If unadjustable, change its value to 5.5 to 18pF trimmer capacitor (refer to paragraph 5-28).
A4C6 (Para. 5-27)	HP P/N: 0121-0036 C: Trim 5.5/18pF HP P/N: 0121-0105 C: Trim 9/35pF	Minimizes dissipation measurement error. If unadjustable with only A4ADJ10 (A4C6), change its value to 9 to 35pF (refer to paragraph 5-27).
A4C8 (Para. 5-30)	HP P/N: 0140-0192 C: FXD 68pF HP P/N: 0160-2201 C: FXD 51pF HP P/N: 0160-2150 C: FXD 33pF HP P/N: 0160-2263 C: FXD 18pF	Minimizes dissipation measurement error. If the residual display counts on display B is less than -140 counts, increase capacitance value of A4C25.
A4C25 (Para. 5-30)	HP P/N: 0160-2263 C: FXD 18pF HP P/N: 0160-2150 C: FXD 33pF HP P/N: 0160-2201 C: FXD 51pF HP P/N: 0140-0192 C: FXD 68pF	Conversely, residual display counts is greater than -20 counts, increase capacitance value of A4C8.
A4R12 A4R13 A4R54 A4R63 (Para. 5-20)	HP P/N: 0698-3155 R: FXD 4.64k $\Omega$ HP P/N: 0698-3155 R: FXD 4.64k $\Omega$ HP P/N: 0698-3155 R: FXD 4.64k $\Omega$ HP P/N: 0698-3155 R: FXD 4.64k $\Omega$ Jumper wire (0 $\Omega$ )	To minimize residual DC offset voltage in process amplifier (refer to paragraph 5-20).
A4R18 (Para. 5-28)	HP P/N: 0698-3430 R: FXD 21.5 $\Omega$ HP P/N: 0683-1015 R: FXD 100 $\Omega$	Maximizes attenuator accuracy of x1/10 amplifier. If unadjustable with A4ADJ11 (A4R6), add 100 $\Omega$ resistor (refer to paragraph 5-28).
A4R20 (Para. 5-28)	HP P/N: 0698-2283 R: FXD 1.0 $\Omega$ HP P/N: 0683-0565 R: FXD 5.6 $\Omega$	Maximizes attenuator accuracy of x1/100 amplifier. If unadjustable with A4ADJ12 (A4R7), add 5.6 $\Omega$ resistor (refer to paragraph 5-28).

Table 5-2. Factory Selected Components (sheet 2 of 2).

A4R28 (Para. 5-27)	HP P/N: 0683-0565 R: FXD 5.6Ω HP P/N: 0683-1005 R: FXD 10Ω	Maximizes attenuator accuracy of x1/2 amplifier. If unadjustable with only A4ADJ7 (A4R10), add 10Ω resistor (refer to paragraph 5-27).
A4R30 (Para. 5-27)	HP P/N: 0683-0275 R: FXD 2.7Ω HP P/N: 0683-0565 R: FXD 5.6Ω	Maximizes attenuator accuracy of x1/4 amplifier. If unadjustable with only A4ADJ8 (A4R11), add 5.6Ω resistor (refer to paragraph 5-27).
A5C10 (Para. 5-19)	HP P/N: 0160-2203 C: FXD 91pF HP P/N: 0160-2205 C: FXD 120pF HP P/N: 0140-0196 C: FXD 150pF HP P/N: 0140-0197 C: FXD 180pF HP P/N: 0160-0134 C: FXD 220pF HP P/N: 0140-0199 C: FXD 240pF HP P/N: 0140-0210 C: FXD 270pF HP P/N: 0160-2207 C: FXD 300pF HP P/N: 0160-2208 C: FXD 330pF	Minimizes residual input to integrator. If offset value is positive, use capacitor. Changing capacitance value of A5C10 by 30pF causes approximately a 1 count change on Display A.

5-16. INITIAL OPERATING PROCEDURE.

5-17. Preparatory to adjusting the 4274A, do the following to locate and to gain access to the adjustment controls (this procedure facilitates a thoroughgoing adjustment):

FUNDAMENTAL OPERATING CHECKS

Confirm that instrument power line selector switches are set for local power line voltage. Program Memory Test described on page 3-1 and the SELF TEST procedure in Figure 3-0 on page 3-0 should be completely performed and successfully passed before progressing to adjustment procedure.

TOP COVER REMOVAL

WARNING

WHEN TOP COVER IS REMOVED, LIVE PARTS ARE EXPOSED.

Remove top cover as follows:

- Loosen the retaining screw at rear of top cover.
- Pull top cover towards the rear and lift off.

WARNING

TO INSURE PERSONAL SAFETY FROM POSSIBLE ELECTRICAL SHOCK HAZARDS AND RESULTANT INJURY, USE INSULATED ADJUSTMENT TOOL.

Table 5-3. Adjustments Requirement.

Assembly Repaired or Replaced	Required Adjustment
A1 04274-66501 (NULL DET & RANGE RESISTOR)	Para. 5-25 Para. 5-31
A2 04274-66502 (MODULATOR)	Para. 5-23 Para. 5-31
A3 04274-66503 (POWER AMP)	Para. 5-22
A4 04274-66504 (PROCESS AMP)	Para. 5-20 Para. 5-31
A5 04274-66505 (A/D CONVERTER)	Para. 5-19
A6 04274-66506 (OSCILLATOR)	Para. 5-21
A7 04274-66507 (PERIPHERAL CONTROL)	None
A8 04274-66508 (DISPLAY & KEY CONTROL)	None
A9 04274-66513 (MPU)	None
A10 04274-66520 (DISPLAY & KEY)	None
A11 04274-66511 (POWER SUPPLY)	Para. 5-18
A21 04274-66521 (OPT. 001 DC BIAS)	Para. 5-32
A22 04274-66522 (OPT. 101 HPIB)	None
A23 04274-66523 (OPT. 002 DC BIAS)	Para. 5-33

ADJUSTMENTS

5-18. A11 POWER SUPPLY VOLTAGE ADJUSTMENT.

PURPOSE:

This adjustment sets the power supply voltages for the 4274A internal circuits. Although there are 4 power voltages (+5V, -5V, +12V and -12V), only one control, the STANDARD REFERENCE VOLTAGE adjustment plus 5 volts is necessary. Other voltages (-5V, +12V and -12V), are automatically controlled to their appropriate values by the STANDARD VOLTAGE ADJUSTMENT.

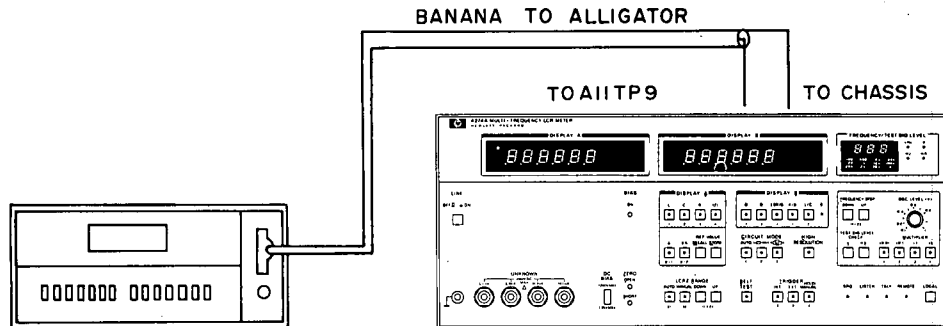

Figure 5-1. All Power Supply Voltage Adjustment.

EQUIPMENT:

DIGITAL VOLTMETER ..... HP 3465B

PROCEDURE:

- a. Set 3465B controls as follows:

FUNCTION ..... V  
RANGE ..... 20V

- b. Connect voltmeter plus input to A11TP9 and minus input to 4274A chassis with dual banana-to-alligator clip cable. See Figure 5-1.
- c. Adjust A11R3 STANDARD VOLTAGE REFERENCE to +5 volts  $\pm 0.01$  volts.
- d. After adjustment of STANDARD VOLTAGE REFERENCE control, check that other DC voltages at TP1, TP5, TP10 and TP17 are within values listed below:

TEST POINT	DVM TOLERANCES	
A11TP17 ( +5V)	4.90	5.10
A11TP10 ( -5V)	-4.90	-5.10
A11TP 1 (+12V)	11.76	12.24
A11TP 5 (-12V)	-11.76	-12.24

- e. Remove dual banana-to-alligator cable and 3465B from 4274A.

ADJUSTMENTS

5-19. A5 ADC DC REFERENCE ADJUSTMENT.

PURPOSE:

To minimize residual input to integrator and to obtain optimum zero detection.

EQUIPMENT:

None.

PROCEDURE:

- a. Connect nothing to 4274A UNKNOWN terminals.
- b. Press, in order, **SELF TEST** and **D** keys and check that the figure "1" is displayed on Display A unit indicator. See figure below.

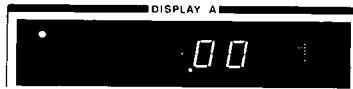

- c. Check that display counts are within  $\pm 5$  counts. No adjustable component.
- d. Adjust DC REF ADJ A5R3 until display count is  $-10 \pm 5$  counts on Display B.

5-20. A4 PROCESS AMPLIFIER DC OFFSET ADJUSTMENT.

PURPOSE:

To minimize residual DC offset voltage in process amplifier.

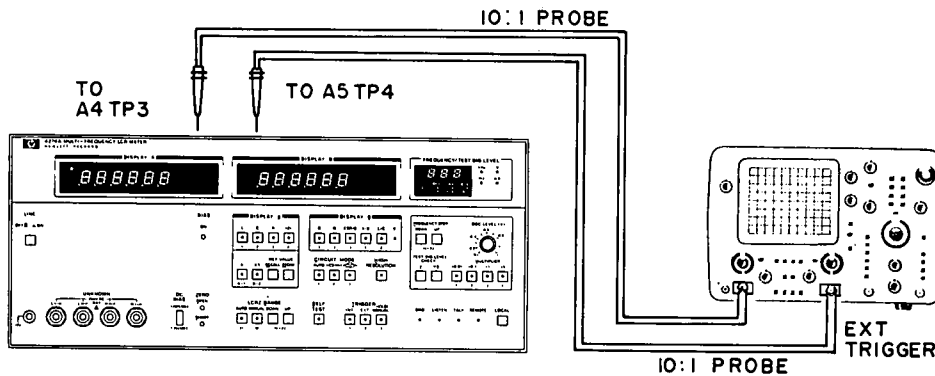

Figure 5-2. A4 Process Amplifier DC Offset Adjustment.

EQUIPMENT:

OSCILLOSCOPE ..... HP 1740A

PROCEDURE:

- a. Set 1740A controls as follows:

VOLTS/DIV ..... .01V/div (USE 10:1 probe)  
TIME/DIV ..... 5ms/div  
INPUT ..... DC  
TRIGGER ..... EXT  
SWEEP ..... NORMAL

ADJUSTMENTS

- b. Remove the three miniature connector cables from A4 board.
- c. Press 4274A **SELF TEST** key and **Δ** key so that the figure "6" appears on unit indicator of Display A.
- d. Connect a 10:1 divider probe between 4274A A4TP3 and chassis. See Figure 5-2.
- e. Connect a 10:1 divider probe between A5TP4 and chassis for EXT TRIGGER input of 1740A. See Figure 5-2.
- f. Adjust A4ADJ1 (A4R5) to flatten and balance square waves ① and ② as shown Figure 5-4 from the waveforms as shown in Figure 5-3.

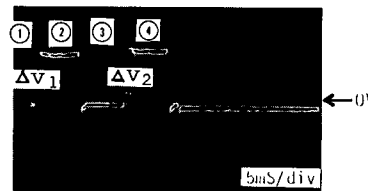

Figure 5-3. Waveforms before Adjustment.

- g. Change 1740A V/DIV setting as appropriate while adjusting for minimum balance ( $\Delta V_1$ ).
- h. In like manner, adjust A4ADJ2 (A4R55) for square waves ③ and ④. The balances ( $\Delta V_1, \Delta V_2$ ) should be within  $\pm 100\text{mV}$  as shown in Figure 5-4.

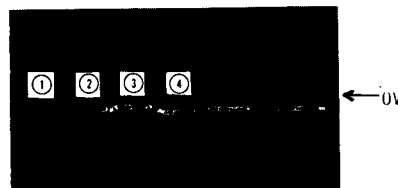

Figure 5-4. Waveforms after Adjustments with A4ADJ1 and A4ADJ2.

- i. Adjust A4ADJ3 (A4R8) until the top of the four (4) square waves is within 0 volts  $\pm 30\text{mV}$ .
- j. The waveforms after typical adjustments of A4ADJ1, A4ADJ2 and A4ADJ3 should be as shown as in Figure 5-5.

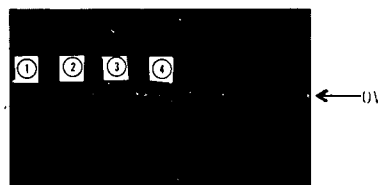

Figure 5-5. Waveforms Typically Adjusted.

- k. Replace the three miniature connector cables on A4 board.

ADJUSTMENTS

Note

If these adjustments can not be made to specified limit, change values of A4R12, A4R13, A4R54 and A4R63 in accordance with table below:

	$\Delta V1 < -100\text{mV}$	$\Delta V1 > +100\text{mV}$	$\Delta V2 < -100\text{mV}$	$\Delta V2 > +100\text{mV}$
Component	A4R12 (4.64k $\Omega$ )	A4R13 (4.64k $\Omega$ )	A4R54 (4.64k $\Omega$ )	A4R63 (4.64k $\Omega$ )
	Jumper Wire (0 $\Omega$ )	Jumper Wire (0 $\Omega$ )	Jumper Wire (0 $\Omega$ )	Jumper Wire (0 $\Omega$ )

Note

If these adjustments still can not be performed after installing jumper wires instead of 4.64k $\Omega$  resistor as listed in above table, proceed to Section VIII A4 troubleshooting.

5-21. A6 OSCILLATOR ADJUSTMENT.

PURPOSE:

To obtain an appropriate oscillation without any visible distortion.

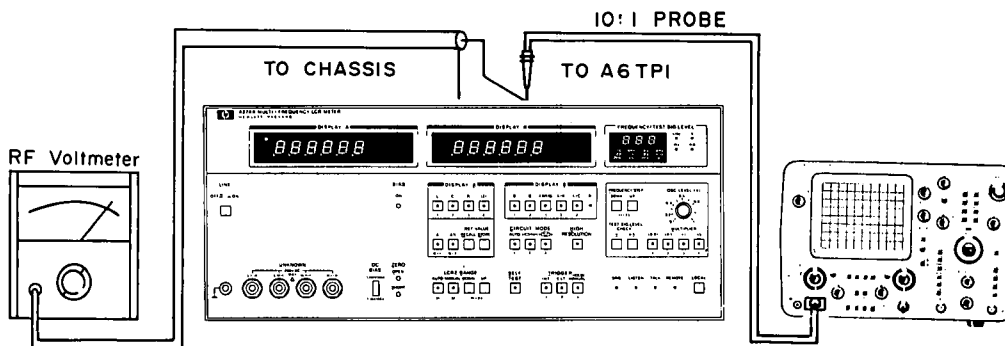

Figure 5-6. A6 Oscillator Adjustment.

EQUIPMENT:

OSCILLOSCOPE ..... HP 1740A  
DVM ..... HP 3400A

PROCEDURE:

a. Set 4274A controls as follows.

SELF TEST ..... OFF  
OTHER CONTROLS ..... Any Settings

CAUTION

VERIFY THAT DC BIAS INDICATOR DOES NOT LIGHT.  
IF ILLUMINATED, SET REAR PANEL DC BIAS SW TO OFF!

ADJUSTMENTS

b. Set oscilloscope controls as follows:

V/DIV ..... 0.02V/div (USE 10:1 probe)  
 INPUT ..... AC  
 SWEEP ..... NORMAL  
 TRIGGER ..... INT

c. Connect 10:1 probe to A6TP1 and ground lead to 4274A chassis as shown in Figure 5-6.

d. Observe displayed waveform at all test frequencies of 4274A and check that these waveforms do not have any visible distortion.

Note

If any distortion or clipping appears, proceed to Section VIII A6 Troubleshooting.

e. Set 4274A FREQUENCY to 1.00kHz.

f. Connect voltmeter plus input to A6TP1 and minus input to 4274A chassis with BNC-to-alligator clip cable.

g. Adjust A6R3 until 3400A reading is 500mVrms.

h. Observe that peak-to-peak values of displayed waveform are within 1.2V P-P to 1.6V P-P for all test frequencies.

5-22. A3 POWER AMPLIFIER ADJUSTMENT.

PURPOSE:

To set appropriate amplitude and to ensure that a clean sinusoidal signal is present at 4274A UNKNOWN terminals.

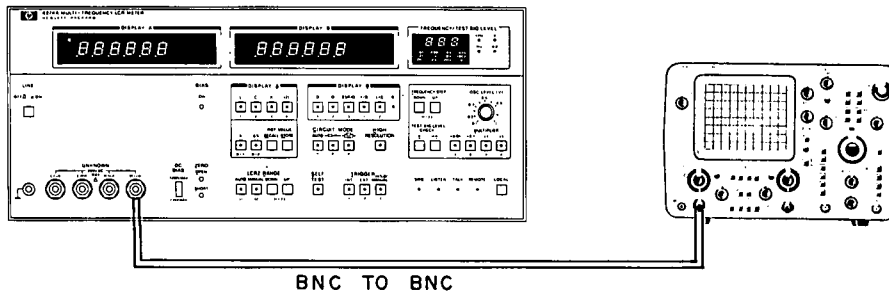

Figure 5-7. A3 Power Amplifier Adjustment.

EQUIPMENT:

OSCILLOSCOPE ..... HP 1740A

PROCEDURE:

a. Set 4274A controls as follows:

MULTIPLIER ..... X1  
 OSC LEVEL ..... CW  
 SELF TEST ..... OFF  
 OTHER CONTROLS ..... Any Settings



ADJUSTMENTS

- b. Connect 1740A input to 4274A H cur BNC connector of UNKNOWN terminals with BNC-to-BNC cable as in Figure 5-7.
- c. Observe that waveforms displayed on oscilloscope for all frequencies from 100Hz to 100kHz are of constant amplitude without any distortion or clipping.
- d. Adjust A3R1 to obtain clean sinusoidal waveform.

Note

Proceed to Section VIII A3 troubleshooting if unable to perform appropriate adjustment with A3R1.

- e. Remove BNC-to-BNC cable and oscilloscope from 4274A.

5-23. A2 90° PHASE ADJUSTMENT.

PURPOSE:

To set any accurate 90° phase shift for 90° phase detector to achieve optimum bridge balance.

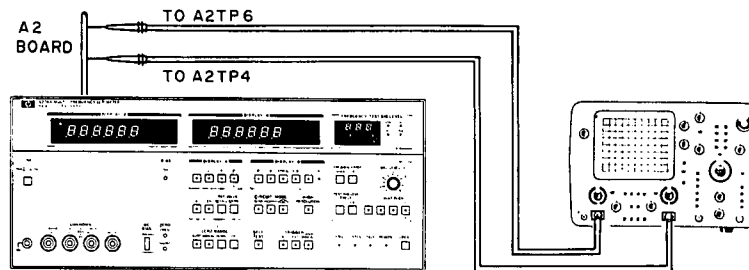

Figure 5-8. A2 90° Phase Adjustment.

EQUIPMENT:

OSCILLOSCOPE ..... HP 1740A

PROCEDURE:

- a. Remove A2 MODULATOR board from 4274A.
- b. Install extender board (HP P/N: 5060-4025) in A2 slot and install A2 board in extender.

Note

Two 5060-4953 22 Pin Extender Boards can be substituted if 5060-4025 are not available.

- c. Set 4274A test frequency to 1kHz.
- d. Set oscilloscope 1740A controls as follows:

VOLT/DIV ..... A CHAN. 0.02V/div (Use 10:1 probe)  
 B CHAN. 0.02V/div (Use 10:1 probe)  
 SWEEP ..... AUTO A VS B

ADJUSTMENTS

- e. Connect channel A input probe to A2TP6 and channel B input probe to A2TP4 as shown Figure 5-8. The Lissajous figure displayed should be as shown Figure 5-9.

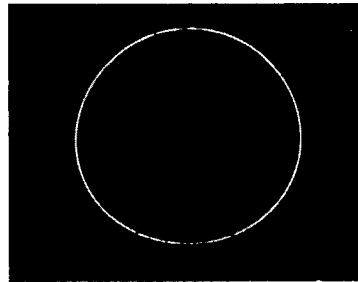

Figure 5-9. Lissajous Waveform.

- f. Adjust A2R43 until a visually recognizably round figure is displayed. Don't be too sensitive about getting a precise circle-shaped figure.
- g. Remove both cables, oscilloscope and extender board from 4274A and replace A2 board.

Note

Proceed to Section VIII A2 MODULATOR troubleshooting if a circle-shaped figure cannot be displayed.

5-24. A2 MODULATOR ZERO OFFSET PREADJUSTMENT.

PURPOSE:

To eliminate residual offset in phase tracking amplifier.

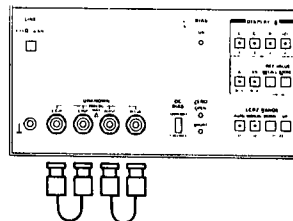

Figure 5-10. A2 Modulator Zero Offset Preadjustment.

EQUIPMENT:

Open termination (os) ..... BNC-to-BNC cable  
(10cm long, 2ea required)

Note

Use OPEN (os) termination of the HP 16074A Standard Resistor Set (if available).

ADJUSTMENTS

PROCEDURE:

- a. Press 4274A **SELF TEST** and **Δ%** keys (in that order) and check that a figure "7" appears on unit indicator of Display A. See figure below.



- b. Set 4274A test frequency to 10kHz and OSC LEVEL to full CW position.
- c. Connect BNC-to-BNC cable between H cur and H pot connectors and another BNC-to-BNC cable between L cur and L pot connectors of 4274A unknown terminals as shown Figure 5-10.
- d. Alternately adjust A2R1 and A2R8 until display counts are within  $\pm 10$  counts for both Display A and Display B. The adjustments of A2R1 and A2R8 are interactive for both displays. Therefore, do the adjustment bit-by-bit.
- e. Change 4274A test frequency to 100kHz and that check display counts are within  $0 \pm 120$  counts for Display A and Display B.
- f. Readjust A2R1 and A2R8 so that display counts are within  $.00 \pm 120$  counts.
- g. Change 4274A test frequency from 100KHz thru 100Hz and that check display counts are within  $.00 \pm 120$  counts for all frequencies.
- h. Remove both BNC-to-BNC cables from 4274A.

5-25. A1 BUFFER AMPLIFIER ADJUSTMENT.

PURPOSE:

To minimize residual offset in buffer amplifier.

EQUIPMENT:

BNC-to-BNC cable ..... 10cm long

ADJUSTMENTS

PROCEDURE:

- a. Confirm that 4274A Self Test function is activated and press **REFERENCE VALUE RECALL** key.
- b. Check that a figure "8" appears on unit indicator of Display A. Set 4274A test frequency to 1kHz. See figure below.



- c. Connect terminals Hcur and Lpot together for a few seconds and then remove the cable from Lpot and connect it to Hpot.
- d. Adjust A1R1 until display counts are within .00±500 counts on Display A.

Note

Proceed to Section VIII A1 troubleshooting if display counts are not within .00±500 counts.

- e. Change 4274A test frequency to 100kHz.
- f. Adjust A1C2 until display count is within .00±300 counts for Display A.
- g. Remove BNC-to-BNC cable from 4274A.

5-26. A2 MODULATOR ZERO OFFSET ADJUSTMENT.

PURPOSE:

To eliminate residual offset from both Phase Detector 0° and 90° integrators.

EQUIPMENT:

Open terminator (os) ..... BNC-to-BNC cable  
(10cm long, 2ea required)

Note

Use Open (os) terminator of 16074A standard Resistor Set if it's available.

PROCEDURE:

- a. Set 4274A controls as follows:
  - FREQUENCY ..... 100kHz
  - MULTIPLIER ..... X1
  - VERNIER ..... full CW
  - SELF TEST ..... ON
  - OTHER CONTROLS ..... Any Settings
- b. Connect BNC-to-BNC cables between H cur and H pot connectors and between L cur and L pot connectors.
- c. Press 4274A **Δ%** key and check that a figure "7" appears on unit indicator of Display A. See figure below.



- d. Alternately adjust A2R1 and A2R8 until both display counts are within .00±10 counts for both Display A and Display B.

ADJUSTMENTS

- e. Press 4274A **STORE** key and press RANGE **UP** or **DOWN** keys until figure a "30" appears on unit indicator of Display B. See figure below.



- f. Check that display counts are within  $.00 \pm 15$  counts for both Display A and Display B. Proceed to Section VIII A4 and A5 troubleshooting if step f cannot be performed.
- g. Change 4274A LEVEL MULTIPLIER to x5 and press RANGE **UP** or **DOWN** key until a figure "31" appears on unit indicator of Display B. See figure below.

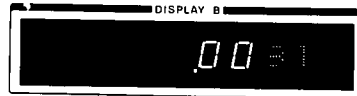

- h. Check that display counts are within  $.00 \pm 15$  counts for both Display A and Display B.

Note

Proceed to Section VIII A4 troubleshooting if step h cannot be performed.

- i. Change 4274A test frequency to 10kHz and press 4274A **Δ%** key.
- j. Check that a figure "7" appears on unit indicator of Display A. See figure below.

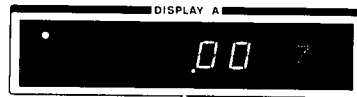

- k. Alternately adjust A2R1 and A2R8 until display counts are within  $.00 \pm 15$  counts for both Display A and Display B.

5-27. A4 x1, x1/2 AND x1/4 ATTENUATER ADJUSTMENT.

PURPOSE:

To set accurate Amplifier gains and attenuations for x1, x1/2 and x1/4 Amplifiers.

EQUIPMENT:

Open termination (os) ..... BNC-to-BNC cable  
(10cm long, 2ea required)

PROCEDURE:

- a. Set 4274A controls as follows:  
 FREQUENCY ..... 1kHz  
 SELF TEST ..... ON  
 OTHER CONTROLS ..... Any Settings
- b. Connect both BNC-to-BNC cables to 4274A UNKNOWN terminals as in 5-26 step b.
- c. Press 4274A **Q** key and check that a figure "2" appears on unit indicator of Display A. See figure below.



ADJUSTMENTS

- d. Adjust A4ADJ7 (A4R10) until display count is within  $-1000.00 \pm 20$  counts.
- e. Change 4274A test frequency to 100kHz.
- f. Adjust A4ADJ10 (A4C6) until display counts are within  $.00 \pm 20$  counts for Display B.
- g. Press 4274A **[ESR/G]** key and check that a figure "3" appears on unit indicator of Display A.
- h. Adjust A4ADJ9 (A4C7) until display counts are within  $.00 \pm 20$  counts for Display B.
- i. Change 4274A test frequency to 1kHz.
- j. Adjust A4ADJ8 (A4R11) until display counts are within  $-1000.00 \pm 20$  counts for Display A.
- k. Leave both BNC-to-BNC cables connected to 4274A UNKNOWN terminals.



Note

If step f is unadjustable with A4ADJ10 (A4C6), refer to Table 5-2 Factory Selected Components on page 5-4. If step h is unadjustable with A4ADJ9 (A4C7), go to A4 troubleshooting tree.

Note

To facilitate easier adjustment, Table 5-6 Adjustment Summary can be used.

5-28. A4 x1, x1/10 and x1/100 ATTENUATOR ADJUSTMENT.

PURPOSE:

To set accurate amplifier gains and attenuations for x1, x1/10 and x1/100 Amplifiers.

EQUIPMENT:

Open termination (os) ..... BNC-to-BNC cable  
(10cm long, 2ea required)

PROCEDURE:

- a. Set 4274A controls as follows:
  - FREQUENCY ..... 1kHz
  - SELF TEST ..... ON

Condition of UNKNOWN terminals is same as for 5-26 step b.
- b. Press 4274A **[x/B]** key and check that a figure "4" appears on unit indicator of Display A. See figure below.



ADJUSTMENTS

- c. Adjust A4ADJ11 (A4R6) until display counts are within  $-1000.00 \pm 20$  counts for Display A.
- d. Change 4274A test frequency to 100kHz.
- e. Adjust A4ADJ14 (A4C4) until display counts are within  $.00 \pm 20$  counts for Display B.
- f. Press 4274A L/C key and check that a figure "5" appears on unit indicator of Display A. See figure below.



- g. Adjust A4ADJ13 (A4C5) until display counts are within  $.00 \pm 20$  counts for Display B.
- h. Change 4274A test frequency to 1kHz.
- i. Adjust A4ADJ12 (A4R7) until display counts are within  $-1000.00 \pm 20$  counts for Display A.

Note

If any steps are unadjustable, refer to Table 5-2 Factory Selected Components on page 5-4.

- j. Remove both BNC-to-BNC cables from 4274A.

Note

To facilitate easier adjustment, Table 5-5 Adjustment Summary can be used.

Table 5-4. 1-1/2-1/4 ATTENUATOR ADJUSTMENTS.

ITEM NUMBER	PRESS →KEY	FREQUENCY	ADJUSTABLE COMPONENTS	DISPLAY A	DISPLAY B
2	<span style="border: 1px solid black; padding: 2px;">Q</span>	1.00kHz 100kHz	A4ADJ7 A4ADJ10	$-1000.00 \pm 20$	$.00 \pm 20$
3	<span style="border: 1px solid black; padding: 2px;">ESR/G</span>	1.00kHz 100kHz	A4ADJ8 A4ADJ9	$-1000.00 \pm 20$	$.00 \pm 20$

Table 5-5. 1-1/10-1/100 ATTENUATOR ADJUSTMENTS.

4	<span style="border: 1px solid black; padding: 2px;">X/B</span>	1.00kHz 100kHz	A4ADJ11 A4ADJ14	$-1000.00 \pm 20$	$.00 \pm 20$
5	<span style="border: 1px solid black; padding: 2px;">L/C</span>	1.00kHz 100kHz	A4ADJ12 A4ADJ13	$-1000.00 \pm 20$	$.00 \pm 20$

ADJUSTMENTS

5-29. A3 TEST SIGNAL LEVEL MONITOR ADJUSTMENT.

PURPOSE:

To establish a precise indication of test signal level when **V** and **mA** are pressed.

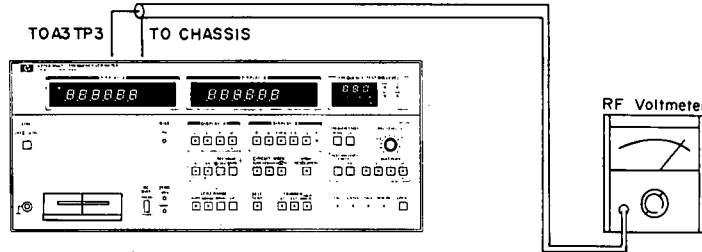

Figure 5-11. A3 Test Signal Level Monitor Adjustment.

EQUIPMENT:

- RF VOLTMETER ..... HP 3400A
- TEST FIXTURE ..... HP 16047A

Note

Use open terminator (os) of 16074A Resistor Standard Set if available.

PROCEDURE:

- a. Rotate OSC LEVEL Vernier fully CW and check that marker pointer of Vernier knob points to a position approximately 10 degrees above the 1 scale reading as shown in figure below.

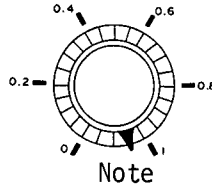

Note

If necessary, loosen the two knob lock screws and reset knob.

- b. Set 4274A controls as follows:

- FREQUENCY ..... 1.00kHz
- OSC LEVEL ..... 1 (exactly)
- MULTIPLIER ..... X5
- SELF TEST ..... OFF
- OTHER CONTROLS ..... Any Settings

- c. Connect 16047A to 4274A UNKNOWN terminals as shown Figure 5-11.
- d. Press 4274A TEST SIGNAL LEVEL CHECK **V** key and check that lamp changes from kHz to V.
- e. Read and note the displayed value of test signal level while **V** key is being pressed.
- f. Change OSC LEVEL CCW to 0.1 and adjust A3R16 until the display value is 1/10 of the display value noted in step e.
- g. Change OSC LEVEL CW to 1 and adjust A3R1 until 5.00Vrms is displayed.



ADJUSTMENTS

- h. Repeat steps e through g as necessary.
- i. Check respective display values for other combinations of MULTIPLIER settings and vernier positions as listed in Table 5-6.
- j. Connect voltmeter plus input to A3TP-3 and minus input to 4274A chassis with dual banana-to-alligator clip cable. See Figure 5-11.
- k. Check that voltmeter readings are within the lower and upper limits for their respective settings as listed in Table 5-7.

Table 5-6. Display Limits for OSC Level Monitor.

SETTING	MULTIPLIER	x.01	x.1	x1	x5		
	OSC LEVEL	1	1	1	1	0.6	0.2
DISPLAY	UPPER	.011	.110	1.10	5.10	3.80	1.60
LIMITS	LOWER	.009	.090	.90	4.90	2.20	0.40

Table 5-7. Signal level limits that appear at UNKNOWN Terminals.

4274A SETTING	MULTIPLIER	x.01	x.1	x1	x5		
	OSC LEVEL DISPLAY	.009	.090	.90	1.00	3.00	4.50
VOLTMETER READING LIMITS	UPPER	10mV	92mV	920mV	1.02V	3.06V	4.62V
	LOWER	8mV	88mV	880mV	980mV	2.94V	4.40V

Note

No adjustments or factory selected components are in the 4274A for frequency accuracy. Proceed to Section VIII A6 troubleshooting if Paragraph 4-9 TEST FREQUENCY ACCURACY TEST can not be made as listed in Table 4-2.

- l. Change 4274A controls as follows:

FREQUENCY ..... 1kHz  
 OSC LEVEL ..... 1  
 MULTIPLIER ..... X5  
 SELF TEST ..... OFF  
 OTHER CONTROLS ..... Any Settings

- m. Connect 16047A to 4274A UNKNOWN terminals and connect shorting bar between High and Low Contacts of 16047A.

Note

Use Short (0Ω) termination of 16074A Standard Resistor Set if available.

- n. Press 4274A TEST SIGNAL CHECK mA key and check that lamp mA is lit.
- o. Display should be within 100mA±5mA.

ADJUSTMENTS

5-30. A1 RANGE RESISTOR and A4 BUFFER AMP TRACKING ADJUSTMENT.

PURPOSE:

To establish precise Range Resistor Resistance (which directly affects the accuracies of all functions).

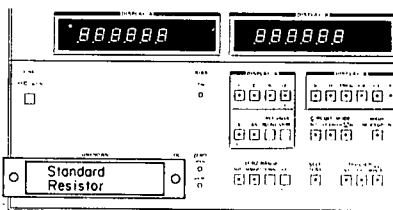

Figure 5-12. A1 Range Resistor and A4 Buffer AMP Tracking Adjustment.

EQUIPMENT:

STANDARD RESISTOR .....	100kΩ±0.03%	} 16074A Standard Resistor Set
Useable frequencies:	10kΩ±0.03%	
(up to 100kHz)	1kΩ±0.03%	
	100Ω±0.03%	

Note

Use 100Ω to 100kΩ resistors from 16074A Standard Resistor Set, if available.

PROCEDURE:

- a. Set 4274A controls as follows:

SELF TEST .....	ON
FREQUENCY .....	1kHz
OSC LEVEL .....	full CW
MULTIPLIER .....	X1

- b. Press 4274A **REFERENCE VALUE STORE** key and check that a figure "μs" appears on unit indicator of Display A. See figure below.
- c. Press RANGE **UP** or **DOWN** key until the figure "50" appears on unit indicator of Display B. See figure below.



Note

These adjustment limits are the nominal resistance values and nominal admittance values and are calculated from a reciprocal number of the resistance value. To establish the actual adjustment limits for proceeding with the following adjustment steps, the calibration data attached to the 16074A or to other resistor standards should be used. For example in step d:

Nominal limit: 100kΩ (nominal) --- 10.0000μs±20 counts

Actual limit: 100.1kΩ (calibration data) --- 9.9900μs±20 counts

- d. Connect 100kΩ resistor to 4274A UNKNOWN terminals as shown Figure 5-12 and adjust (100kΩ) A1R21 until display counts are within \*(10.0000μs±20) counts for Display A.

ADJUSTMENTS

- e. Press 4274A RANGE **UP** or **DOWN** key until the figure "40" appears on unit indicator of Display B. See figure below.

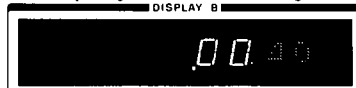

- f. Remove 100k and connect 10kΩ Standard Resistor to 4274A and adjust (10kΩ) A1R18 until display counts are within (100.000μs±20) counts for Display A.

- g. Press 4274A RANGE **UP** or **DOWN** key until the figure "30" appears on unit indicator of Display B. See figure below.

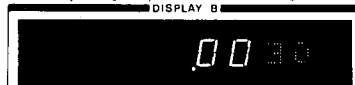

- h. Remove 10kΩ Standard Resistor and connect 1kΩ Standard Resistor to 4274A UNKNOWN terminals and adjust (1kΩ) A1R15 until display counts are within \*(1000.00μs±20) counts for Display A.

- i. Press 4274A RANGE **UP** or **DOWN** key until the figure "20" appears on unit indicator of Display B.



- j. Remove 1kΩ Standard Resistor and connect the 100Ω Resistor Standard to 4274A and adjust (100Ω) A1R12 until display counts are within \*(10.0000ms±20) counts. The 100Ω Resistor Standard should now be left on the 4274A UNKNOWN terminals.

- k. Change 4274A OSC LEVEL MULTIPLIER setting to **x5** key so that the figure "11" appears on the annunciator of Display B.



- l. Adjust (10Ω) A1R8 until display counts are within \*(10.0000Ω±20) counts for Display A.

- m. Change 4274A OSC LEVEL MULTIPLIER setting to x1 and FREQUENCY setting to 100kHz.

- n. Press 4274A RANGE **UP** or **DOWN** keys until the figures "Ω" and "20", respectively, appear on Display A and Display B.

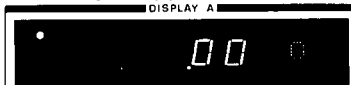

- o. Adjust A4ADJ4 A4R1 until display counts are within \*(100.000Ω±20) counts for Display A.

- p. Adjust A4ADJ5 (A4C3) until display counts are within .020±20 counts for Display B.

- q. Remove 100Ω Standard Resistor from 4274A UNKNOWN terminals.

Note

If step p is unadjustable with A4ADJ5 (A4C3), refer to Table 5-2 (Factory Adjust Components).

To facilitate easier adjustment, Table 5-8 Adjustment Summary can be used.

ADJUSTMENTS

Table 5-8(a). Adjustment Summary (of step a thru e).

Display-B Unit Indication	Press→Key	Resistor Standard	Adjustable Component(s)	Display-A (Nominal)	Display-A (Actual)
50	RANGE <input type="button" value="UP"/> <input type="button" value="DOWN"/>	100kΩ	100kΩ (A1R21)	10.0000μs±20	$\frac{1}{C.R.V.} s \pm 20$
40	RANGE <input type="button" value="UP"/> <input type="button" value="DOWN"/>	10kΩ	10kΩ (A1R18)	100.000μs±20	$\frac{1}{C.R.V.} s \pm 20$
30	RANGE <input type="button" value="UP"/> <input type="button" value="DOWN"/>	1kΩ	1kΩ (A1R15)	1000.00μs±20	$\frac{1}{C.R.V.} s \pm 20$
20	RANGE <input type="button" value="UP"/> <input type="button" value="DOWN"/>	100Ω	100Ω (A1R12)	10.0000μs±20	$\frac{1}{C.R.V.} s \pm 20$
11	MULTIPLIER <input type="button" value="x5"/>	100Ω	10Ω (A1R 8)	10.0000Ω±20	$\frac{C.R.V.}{10} \pm 20$

C.R.V. .... calibrated resistance value

Table 5-8 (b). Adjustment Summary (of steps m thru q).

A4ADJ4	..... Display A	..... 100.000Ω±20 (C.R.V.Ω±20)
A4ADJ5	..... Display B	..... 20±20

5-31. A1 RANGE RESISTOR PHASE ADJUSTMENT.

PURPOSE:

To minimize residual phase offset that especially occurs at high frequencies in Range Resistor of bridge circuit.

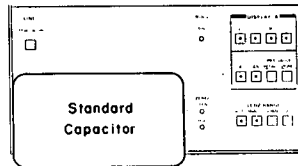

Figure 5-13. A1 Range Resistor Phase Adjustment.

EQUIPMENT:

STANDARD CAPACITORS .....  $\left( \begin{array}{l} 1pF: \text{ HP 16381A} \\ 10pF: \text{ HP 16382A} \\ 100pF: \text{ HP 16383A} \\ 1000pF: \text{ HP 16384A} \end{array} \right)$   
(Useable frequencies:  
up to 100kHz)

PROCEDURE:

a. Set 4274A controls as follows:

SELF TEST ..... ON  
FREQUENCY ..... 100kHz  
OSC LEVEL ..... full CW  
MULTIPLIER ..... x1  
OTHER CONTROLS ..... Any Settings

b. Press 4274A  key and RANGE  or  keys until the figure "50" appears on unit indicator of Display B. See figure below.

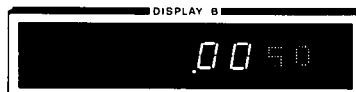

ADJUSTMENTS

- c. Connect 10pF Standard Capacitor (16382A) to 4274A as shown in Figure 5-13 and adjust A1C11 (100kΩφ) until display counts are within .0000μs±4% counts for Display A.
- d. Remove 10pF Standard Capacitor (16382A) from 4274A and connect 100pF Capacitor Standard (16383A) to 4274A UNKNOWN terminals.
- e. Press 4274A RANGE **UP** or **DOWN** key until the figure "40" appears on unit indicator of Display B. See figure below.



- f. Adjust A1C10 (10kΩφ) until display counts are within .000μs±3% counts for Display A.
- g. Remove 100pF Standard Capacitor (16383A) from 4274A and connect 1000pF Standard Capacitor (16384A) to 4274A UNKNOWN terminals.
- h. Press 4274A RANGE **UP** or **DOWN** key until the figure "30" appears on unit indicator of Display B. See figure below.

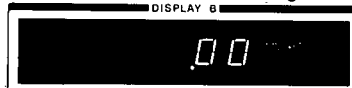

- i. Adjust A1C9 (1kΩφ) until display counts are within .00μs±3% counts for Display A.
- j. Remove 1000pF Capacitor Standard (16384A) from 4274A and connect 100Ω Standard Resistor to 4274A UNKNOWN terminals.
- k. Change Multiplier to x5 and press 4274A RANGE **UP** or **DOWN** key until the figure "Ω" and "11", respectively, appear on unit indicators for Display A and Display B.



- l. Adjust A1C7 (10Ωφ) until display counts are within .020±20 counts for Display B.

Note

If only A1C7 (10Ωφ) in step l is unadjustable, refer to Table 5-2 (Factory Adjust Components).

Note

To facilitate easier adjustment, Table 5-9 Adjustment Summary can be used.

Table 5-9. Adjustment Summary.

Item Number	Standard	Adjust	Display	Count Limits
50	10pF	100kΩφ (A1C11)		.0000μs±4%
40	100pF	10kΩφ (A1C10)	A	.000μs±3%
30	1000pF	1kΩφ (A1C9)		.00μs±3%
11	100Ω	10Ωφ (A1C7)	B	.020±20

ADJUSTMENTS

5-32. A21 INTERNAL DC BIAS SUPPLY ADJUSTMENT (0 to ±35V).

PURPOSE:

To set internal DC voltage and the gain of DAC and Amplifier so that accurate DC bias voltages can be applied to the sample when controlled with 16023B BIAS CONTROLLER. A21 (or A23)

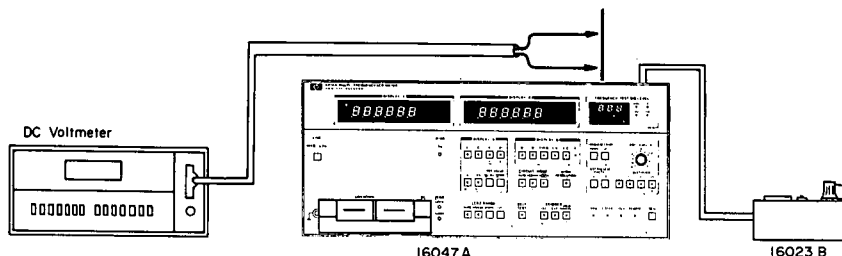

Figure 5-14. A21 (or A23) Internal DC Bias Supply Adjustment (0 to ±35V).

EQUIPMENT:

BIAS CONTROLLER ..... HP 16023B  
DIGITAL VOLTMETER ..... HP 3465B

PROCEDURE:

a. Set 4274A controls as follows.

DC BIAS SWITCH ..... ±35V MAX  
Display A ..... C  
TRIGGER ..... Manual  
MULTIPLIER ..... x.01  
OSC LEVEL ..... full CCW  
OTHER CONTROLS ..... Any Settings  
DC BIAS SELECTOR SW ..... INT 35V/100V (C<.1μF)  
(REAR PANNEL)

b. Set 16023B DC Bias Controller thumbwheel switch to 0.00 and connect its 24 pin male connector to BIAS CONTROL connector on the rear panel of the 4274A. See Figure 5-14.

c. Remove A21 board and install board extender in A21 slot and install A21 board in extender.

CAUTION

Before removing A21 board, DC Bias connector board must be pulled out toward the rear panel by loosening its two screws.

d. Set 3465B controls as follows:

FUNCTION ..... V  
RANGE ..... 200V

e. Connect 3465B plus input to the negative lead of A21C19 (-42V) and minus input to the positive lead of A21C19 (GND▽) with dual banana to alligator clip cable.

f. Adjust A21R83 so the 3465B reads -42V±0.1V and check that the voltage across A21C18 is within +42V±1.0V.

Note

Change 3465B Range control to the appropriate setting for the adjustments that follow.

ADJUSTMENTS

- g. Change 16023B thumbwheel switch setting to  $-.00V \times 1$  and press ENTER button.
- h. Connect 3465B plus input to A21TP3 and minus input to x/A 16R connector pin (GND $\nabla$ ).
- i. Adjust A21R12 until the 3465B reads  $0V \pm 0.1mV$ .
- j. Change 16023B thumbwheel switch setting to  $+.00V \times 1$  and press ENTER button.
- k. Adjust A21R11 until the 3465B reads  $0V \pm 0.1mV$ .
- l. Remove 3465B plus input from A21TP3 and connect to TP2.
- m. Adjust A21R8 until the 3465B reads  $0V \pm 0.1mV$ .
- n. Change 16023B thumbwheel switch setting to  $-9.00V \times 1$  and press ENTER button.
- o. Adjust A21R13 until the 3465B reads  $-9V \pm .002V$ .
- p. Remove dual banana to alligator clip cable, 3465B and 16023B from 4274A.

Note

Although the variable resistor A21R48 is mounted on the A21 board, it is a "factory only" adjustable component and is not field adjustable.

5-33. A23 INTERNAL DC BIAS SUPPLY ADJUSTMENT (0 to  $\pm 100V$ ).

PURPOSE and EQUIPMENT:

Same as in Para. 5-32.

PROCEDURE:

- a. Set 4274A controls as follows:
  - DC BIAS SWITCH .....  $\pm 200V$  MAX
  - TRIGGER ..... Manual
  - DISPLAY A ..... C
  - OSC LEVEL ..... full CCW
  - OTHER CONTROLS ..... Any Settings
  - DC BIAS SELECTOR SW ... INT 35V/100V (C $<.1\mu F$ )  
(REAR PANEL)
- b. Set 16023B DC Bias Controller thumbwheel switch to .000 and connect its 24 pin male connector to Bias Controller connector on the rear panel of 4274A. Refer to Figure 5-14 except for the difference in test pins and board number.
- c. Remove A23 board and install board extender in A23 slot and install A23 board in extender.

Note

Before removing A23 board, DC Bias connector board must be pulled out toward rear panel by loosening its two screws.

## ADJUSTMENTS

- d. Set 3465B controls as follows:

FUNCTION ..... V  
RANGE ..... 200V

- e. Connect 3465B plus input to the negative lead of A23C26 and minus input to the positive lead of A23C26 with dual banana to alligator clip cable.
- f. Adjust A23R55 until the 3465B reads  $-42V \pm 0.1V$ .

## Note

Change 3465B Range Control to the appropriate setting for the adjustments that follow.

- g. Connect 3465B plus input to the A23TP2 and minus input to the x/A 16R connector pin (GND $\nabla$ ).
- h. Set 16023B thumbwheel switch control to  $-.00V \times 1$  and press ENTER button.
- i. Adjust A23R11 until the 3465B reads  $0V \pm 0.1mV$ .
- j. Change 16023B thumbwheel switch setting to  $+0.00 \times 1$  and press ENTER button.
- k. Adjust A23R10 until the 3465B reads  $0 \pm 0.1mV$ .
- l. Connect 3465B plus input to A23TP1 and minus input to the x/A 16R connector pin.
- m. Change 16023B thumbwheel switch setting  $-0.00V \times 1$  and press ENTER button.
- n. Adjust A23R8 until the 3465B reads  $0V \pm 2mV$ .
- o. Change 16023B thumbwheel switch setting to  $-9.00V \times 1$  and press ENTER button.
- p. Adjust A23R9 until the 3465B reads  $-90V \pm 40mV$ .
- q. Remove dual banana to alligator clip cable, 3465B and 16023B from 4274A.



## SECTION VI REPLACEABLE PARTS

### 6-1. INTRODUCTION.

6-2. This section contains information for ordering parts. Table 6-1 lists abbreviations used in the parts list and throughout the manual. Table 6-3 lists all replaceable parts in reference designator order. Table 6-2 contains the names and addresses that correspond to the manufacturer's code numbers.

### 6-3. ABBREVIATIONS.

6-4. Table 6-1 lists abbreviations used in parts list, schematics and throughout the manual. In some cases, two forms of abbreviations are used, one in all capital letters, and one in partial capitals or no capitals. This occurs because the abbreviations in parts list are always all capitals. However, in the schematics and in other parts of the manual, other abbreviation forms with both lower case and upper case letters are used.

### 6-5. REPLACEABLE PARTS LIST.

6-6. Table 6-3 is a list of replaceable parts and is organized as follows:

- a. Electrical assemblies and their components in alphanumerical order by reference designation.
- b. Chassis-mounted parts in alphanumerical order by reference designation.
- c. Miscellaneous parts.
- d. Illustrated parts breakdowns, if appropriate.

The information for each part includes:

- a. The Hewlett-Packard part number.
- b. The total quantity (Qty) in the instrument.

**Table 6-1. List of Reference Designators and Abbreviations**

REFERENCE DESIGNATORS																																																																																																																																																																																																																																																									
<table style="width: 100%; border: none;"> <tr><td>A</td><td>= assembly</td></tr> <tr><td>B</td><td>= motor</td></tr> <tr><td>BT</td><td>= battery</td></tr> <tr><td>C</td><td>= capacitor</td></tr> <tr><td>CP</td><td>= coupler</td></tr> <tr><td>CR</td><td>= diode</td></tr> <tr><td>DL</td><td>= delay line</td></tr> <tr><td>DS</td><td>= device signaling (lamp)</td></tr> </table>	A	= assembly	B	= motor	BT	= battery	C	= capacitor	CP	= coupler	CR	= diode	DL	= delay line	DS	= device signaling (lamp)	<table style="width: 100%; border: none;"> <tr><td>E</td><td>= misc electronic part</td></tr> <tr><td>F</td><td>= fuse</td></tr> <tr><td>FL</td><td>= filter</td></tr> <tr><td>J</td><td>= jack</td></tr> <tr><td>K</td><td>= relay</td></tr> <tr><td>L</td><td>= inductor</td></tr> <tr><td>M</td><td>= meter</td></tr> <tr><td>MP</td><td>= mechanical part</td></tr> </table>	E	= misc electronic part	F	= fuse	FL	= filter	J	= jack	K	= relay	L	= inductor	M	= meter	MP	= mechanical part	<table style="width: 100%; border: none;"> <tr><td>P</td><td>= plug</td></tr> <tr><td>Q</td><td>= transistor</td></tr> <tr><td>R</td><td>= resistor</td></tr> <tr><td>RT</td><td>= thermistor</td></tr> <tr><td>S</td><td>= switch</td></tr> <tr><td>T</td><td>= transformer</td></tr> <tr><td>TB</td><td>= terminal board</td></tr> <tr><td>TP</td><td>= test point</td></tr> </table>	P	= plug	Q	= transistor	R	= resistor	RT	= thermistor	S	= switch	T	= transformer	TB	= terminal board	TP	= test point	<table style="width: 100%; border: none;"> <tr><td>U</td><td>= integrated circuit</td></tr> <tr><td>V</td><td>= vacuum, tube, neon bulb, photocell, etc.</td></tr> <tr><td>VR</td><td>= voltage regulator</td></tr> <tr><td>W</td><td>= cable</td></tr> <tr><td>X</td><td>= socket</td></tr> <tr><td>Y</td><td>= crystal</td></tr> </table>	U	= integrated circuit	V	= vacuum, tube, neon bulb, photocell, etc.	VR	= voltage regulator	W	= cable	X	= socket	Y	= crystal																																																																																																																																																																																										
A	= assembly																																																																																																																																																																																																																																																								
B	= motor																																																																																																																																																																																																																																																								
BT	= battery																																																																																																																																																																																																																																																								
C	= capacitor																																																																																																																																																																																																																																																								
CP	= coupler																																																																																																																																																																																																																																																								
CR	= diode																																																																																																																																																																																																																																																								
DL	= delay line																																																																																																																																																																																																																																																								
DS	= device signaling (lamp)																																																																																																																																																																																																																																																								
E	= misc electronic part																																																																																																																																																																																																																																																								
F	= fuse																																																																																																																																																																																																																																																								
FL	= filter																																																																																																																																																																																																																																																								
J	= jack																																																																																																																																																																																																																																																								
K	= relay																																																																																																																																																																																																																																																								
L	= inductor																																																																																																																																																																																																																																																								
M	= meter																																																																																																																																																																																																																																																								
MP	= mechanical part																																																																																																																																																																																																																																																								
P	= plug																																																																																																																																																																																																																																																								
Q	= transistor																																																																																																																																																																																																																																																								
R	= resistor																																																																																																																																																																																																																																																								
RT	= thermistor																																																																																																																																																																																																																																																								
S	= switch																																																																																																																																																																																																																																																								
T	= transformer																																																																																																																																																																																																																																																								
TB	= terminal board																																																																																																																																																																																																																																																								
TP	= test point																																																																																																																																																																																																																																																								
U	= integrated circuit																																																																																																																																																																																																																																																								
V	= vacuum, tube, neon bulb, photocell, etc.																																																																																																																																																																																																																																																								
VR	= voltage regulator																																																																																																																																																																																																																																																								
W	= cable																																																																																																																																																																																																																																																								
X	= socket																																																																																																																																																																																																																																																								
Y	= crystal																																																																																																																																																																																																																																																								
ABBREVIATIONS																																																																																																																																																																																																																																																									
<table style="width: 100%; border: none;"> <tr><td>A</td><td>= amperes</td></tr> <tr><td>A. F. C.</td><td>= automatic frequency control</td></tr> <tr><td>AMPL</td><td>= amplifier</td></tr> <tr><td>B. F. O.</td><td>= beat frequency oscillator</td></tr> <tr><td>BE CU</td><td>= beryllium copper</td></tr> <tr><td>BH</td><td>= binder head</td></tr> <tr><td>BP</td><td>= bandpass</td></tr> <tr><td>BRS</td><td>= brass</td></tr> <tr><td>BWO</td><td>= backward wave oscillator</td></tr> <tr><td>CCW</td><td>= counter-clockwise</td></tr> <tr><td>CER</td><td>= ceramic</td></tr> <tr><td>CMO</td><td>= cabinet mount only</td></tr> <tr><td>COEF</td><td>= coefficient</td></tr> <tr><td>COM</td><td>= common</td></tr> <tr><td>COMP</td><td>= composition</td></tr> <tr><td>COMPL</td><td>= complete</td></tr> <tr><td>CONN</td><td>= connector</td></tr> <tr><td>CP</td><td>= cadmium plate</td></tr> <tr><td>CRT</td><td>= cathode-ray tube</td></tr> <tr><td>CW</td><td>= clockwise</td></tr> <tr><td>DEPC</td><td>= deposited carbon</td></tr> <tr><td>DR</td><td>= drive</td></tr> <tr><td>ELECT</td><td>= electrolytic</td></tr> <tr><td>ENCAP</td><td>= encapsulated</td></tr> <tr><td>EXT</td><td>= external</td></tr> <tr><td>F</td><td>= farads</td></tr> <tr><td>f</td><td>= femto = 10<sup>-15</sup></td></tr> <tr><td>FH</td><td>= flat head</td></tr> <tr><td>FIL H</td><td>= fillister head</td></tr> <tr><td>FXD</td><td>= fixed</td></tr> <tr><td>G</td><td>= giga = 10<sup>9</sup></td></tr> <tr><td>GE</td><td>= germanium</td></tr> <tr><td>GL</td><td>= glass</td></tr> <tr><td>GRD</td><td>= ground(ed)</td></tr> </table>	A	= amperes	A. F. C.	= automatic frequency control	AMPL	= amplifier	B. F. O.	= beat frequency oscillator	BE CU	= beryllium copper	BH	= binder head	BP	= bandpass	BRS	= brass	BWO	= backward wave oscillator	CCW	= counter-clockwise	CER	= ceramic	CMO	= cabinet mount only	COEF	= coefficient	COM	= common	COMP	= composition	COMPL	= complete	CONN	= connector	CP	= cadmium plate	CRT	= cathode-ray tube	CW	= clockwise	DEPC	= deposited carbon	DR	= drive	ELECT	= electrolytic	ENCAP	= encapsulated	EXT	= external	F	= farads	f	= femto = 10 <sup>-15</sup>	FH	= flat head	FIL H	= fillister head	FXD	= fixed	G	= giga = 10 <sup>9</sup>	GE	= germanium	GL	= glass	GRD	= ground(ed)	<table style="width: 100%; border: none;"> <tr><td>H</td><td>= henries</td></tr> <tr><td>HEX</td><td>= hexagonal</td></tr> <tr><td>HG</td><td>= mercury</td></tr> <tr><td>HR</td><td>= hour(s)</td></tr> <tr><td>Hz</td><td>= hertz</td></tr> <tr><td>IF</td><td>= intermediate freq.</td></tr> <tr><td>IMPG</td><td>= impregnated</td></tr> <tr><td>INCD</td><td>= incandescent</td></tr> <tr><td>INCL</td><td>= include(s)</td></tr> <tr><td>INS</td><td>= insulation(ed)</td></tr> <tr><td>INT</td><td>= internal</td></tr> <tr><td>k</td><td>= kilo = 1000</td></tr> <tr><td>LH</td><td>= left hand</td></tr> <tr><td>LIN</td><td>= linear taper</td></tr> <tr><td>LK WASH</td><td>= lock washer</td></tr> <tr><td>LOG</td><td>= logarithmic taper</td></tr> <tr><td>LPF</td><td>= low pass filter</td></tr> <tr><td>m</td><td>= milli = 10<sup>-3</sup></td></tr> <tr><td>M</td><td>= meg = 10<sup>6</sup></td></tr> <tr><td>MET FLM</td><td>= metal film</td></tr> <tr><td>MET OX</td><td>= metallic oxide</td></tr> <tr><td>MFR</td><td>= manufacturer</td></tr> <tr><td>MINAT</td><td>= miniature</td></tr> <tr><td>MOM</td><td>= momentary</td></tr> <tr><td>MTG</td><td>= mounting</td></tr> <tr><td>MY</td><td>= "mylar"</td></tr> <tr><td>n</td><td>= nano = 10<sup>-9</sup></td></tr> <tr><td>N/C</td><td>= normally closed</td></tr> <tr><td>NE</td><td>= neon</td></tr> <tr><td>NI PL</td><td>= nickel plate</td></tr> <tr><td>N/O</td><td>= normally open</td></tr> <tr><td>NPO</td><td>= negative positive zero (zero temperature coefficient)</td></tr> </table>	H	= henries	HEX	= hexagonal	HG	= mercury	HR	= hour(s)	Hz	= hertz	IF	= intermediate freq.	IMPG	= impregnated	INCD	= incandescent	INCL	= include(s)	INS	= insulation(ed)	INT	= internal	k	= kilo = 1000	LH	= left hand	LIN	= linear taper	LK WASH	= lock washer	LOG	= logarithmic taper	LPF	= low pass filter	m	= milli = 10 <sup>-3</sup>	M	= meg = 10 <sup>6</sup>	MET FLM	= metal film	MET OX	= metallic oxide	MFR	= manufacturer	MINAT	= miniature	MOM	= momentary	MTG	= mounting	MY	= "mylar"	n	= nano = 10 <sup>-9</sup>	N/C	= normally closed	NE	= neon	NI PL	= nickel plate	N/O	= normally open	NPO	= negative positive zero (zero temperature coefficient)	<table style="width: 100%; border: none;"> <tr><td>NPN</td><td>= negative-positive-negative</td></tr> <tr><td>NRFR</td><td>= not recommended for field replacement</td></tr> <tr><td>NSR</td><td>= not separately replaceable</td></tr> <tr><td>OBD</td><td>= order by description</td></tr> <tr><td>OH</td><td>= oval head</td></tr> <tr><td>OX</td><td>= oxide</td></tr> <tr><td>P</td><td>= peak</td></tr> <tr><td>PC</td><td>= printed circuit</td></tr> <tr><td>p</td><td>= pico = 10<sup>-12</sup></td></tr> <tr><td>PH BRZ</td><td>= phosphor bronze</td></tr> <tr><td>PHL</td><td>= Phillips</td></tr> <tr><td>PIV</td><td>= peak inverse voltage</td></tr> <tr><td>PNP</td><td>= positive-negative-positive</td></tr> <tr><td>P/O</td><td>= part of</td></tr> <tr><td>POLY</td><td>= polystyrene</td></tr> <tr><td>PORC</td><td>= porcelain</td></tr> <tr><td>POS</td><td>= position(s)</td></tr> <tr><td>POT</td><td>= potentiometer</td></tr> <tr><td>PP</td><td>= peak-to-peak</td></tr> <tr><td>PT</td><td>= point</td></tr> <tr><td>PWV</td><td>= peak working voltage</td></tr> <tr><td>RECT</td><td>= rectifier</td></tr> <tr><td>RF</td><td>= radio frequency</td></tr> <tr><td>RH</td><td>= round head or right hand</td></tr> <tr><td>RMO</td><td>= rack mount only</td></tr> <tr><td>RMS</td><td>= root-mean square</td></tr> </table>	NPN	= negative-positive-negative	NRFR	= not recommended for field replacement	NSR	= not separately replaceable	OBD	= order by description	OH	= oval head	OX	= oxide	P	= peak	PC	= printed circuit	p	= pico = 10 <sup>-12</sup>	PH BRZ	= phosphor bronze	PHL	= Phillips	PIV	= peak inverse voltage	PNP	= positive-negative-positive	P/O	= part of	POLY	= polystyrene	PORC	= porcelain	POS	= position(s)	POT	= potentiometer	PP	= peak-to-peak	PT	= point	PWV	= peak working voltage	RECT	= rectifier	RF	= radio frequency	RH	= round head or right hand	RMO	= rack mount only	RMS	= root-mean square	<table style="width: 100%; border: none;"> <tr><td>RWV</td><td>= reverse working voltage</td></tr> <tr><td>S-B</td><td>= slow-blow</td></tr> <tr><td>SCR</td><td>= screw</td></tr> <tr><td>SE</td><td>= selenium</td></tr> <tr><td>SECT</td><td>= section(s)</td></tr> <tr><td>SEMICON</td><td>= semiconductor</td></tr> <tr><td>SI</td><td>= silicon</td></tr> <tr><td>SIL</td><td>= silver</td></tr> <tr><td>SL</td><td>= slide</td></tr> <tr><td>SPG</td><td>= spring</td></tr> <tr><td>SPL</td><td>= special</td></tr> <tr><td>SST</td><td>= stainless steel</td></tr> <tr><td>SR</td><td>= split ring</td></tr> <tr><td>STL</td><td>= steel</td></tr> <tr><td>TA</td><td>= tantalum</td></tr> <tr><td>TD</td><td>= time delay</td></tr> <tr><td>TGL</td><td>= toggle</td></tr> <tr><td>THD</td><td>= thread</td></tr> <tr><td>TI</td><td>= titanium</td></tr> <tr><td>TOL</td><td>= tolerance</td></tr> <tr><td>TRIM</td><td>= trimmer</td></tr> <tr><td>TWT</td><td>= traveling wave tube</td></tr> <tr><td>μ</td><td>= micro = 10<sup>-6</sup></td></tr> <tr><td>VAR</td><td>= variable</td></tr> <tr><td>VDCW</td><td>= dc working volts</td></tr> <tr><td>W/</td><td>= with</td></tr> <tr><td>W</td><td>= watts</td></tr> <tr><td>WIV</td><td>= working inverse voltage</td></tr> <tr><td>WW</td><td>= wirewound</td></tr> <tr><td>W'O</td><td>= without</td></tr> </table>	RWV	= reverse working voltage	S-B	= slow-blow	SCR	= screw	SE	= selenium	SECT	= section(s)	SEMICON	= semiconductor	SI	= silicon	SIL	= silver	SL	= slide	SPG	= spring	SPL	= special	SST	= stainless steel	SR	= split ring	STL	= steel	TA	= tantalum	TD	= time delay	TGL	= toggle	THD	= thread	TI	= titanium	TOL	= tolerance	TRIM	= trimmer	TWT	= traveling wave tube	μ	= micro = 10 <sup>-6</sup>	VAR	= variable	VDCW	= dc working volts	W/	= with	W	= watts	WIV	= working inverse voltage	WW	= wirewound	W'O	= without		
A	= amperes																																																																																																																																																																																																																																																								
A. F. C.	= automatic frequency control																																																																																																																																																																																																																																																								
AMPL	= amplifier																																																																																																																																																																																																																																																								
B. F. O.	= beat frequency oscillator																																																																																																																																																																																																																																																								
BE CU	= beryllium copper																																																																																																																																																																																																																																																								
BH	= binder head																																																																																																																																																																																																																																																								
BP	= bandpass																																																																																																																																																																																																																																																								
BRS	= brass																																																																																																																																																																																																																																																								
BWO	= backward wave oscillator																																																																																																																																																																																																																																																								
CCW	= counter-clockwise																																																																																																																																																																																																																																																								
CER	= ceramic																																																																																																																																																																																																																																																								
CMO	= cabinet mount only																																																																																																																																																																																																																																																								
COEF	= coefficient																																																																																																																																																																																																																																																								
COM	= common																																																																																																																																																																																																																																																								
COMP	= composition																																																																																																																																																																																																																																																								
COMPL	= complete																																																																																																																																																																																																																																																								
CONN	= connector																																																																																																																																																																																																																																																								
CP	= cadmium plate																																																																																																																																																																																																																																																								
CRT	= cathode-ray tube																																																																																																																																																																																																																																																								
CW	= clockwise																																																																																																																																																																																																																																																								
DEPC	= deposited carbon																																																																																																																																																																																																																																																								
DR	= drive																																																																																																																																																																																																																																																								
ELECT	= electrolytic																																																																																																																																																																																																																																																								
ENCAP	= encapsulated																																																																																																																																																																																																																																																								
EXT	= external																																																																																																																																																																																																																																																								
F	= farads																																																																																																																																																																																																																																																								
f	= femto = 10 <sup>-15</sup>																																																																																																																																																																																																																																																								
FH	= flat head																																																																																																																																																																																																																																																								
FIL H	= fillister head																																																																																																																																																																																																																																																								
FXD	= fixed																																																																																																																																																																																																																																																								
G	= giga = 10 <sup>9</sup>																																																																																																																																																																																																																																																								
GE	= germanium																																																																																																																																																																																																																																																								
GL	= glass																																																																																																																																																																																																																																																								
GRD	= ground(ed)																																																																																																																																																																																																																																																								
H	= henries																																																																																																																																																																																																																																																								
HEX	= hexagonal																																																																																																																																																																																																																																																								
HG	= mercury																																																																																																																																																																																																																																																								
HR	= hour(s)																																																																																																																																																																																																																																																								
Hz	= hertz																																																																																																																																																																																																																																																								
IF	= intermediate freq.																																																																																																																																																																																																																																																								
IMPG	= impregnated																																																																																																																																																																																																																																																								
INCD	= incandescent																																																																																																																																																																																																																																																								
INCL	= include(s)																																																																																																																																																																																																																																																								
INS	= insulation(ed)																																																																																																																																																																																																																																																								
INT	= internal																																																																																																																																																																																																																																																								
k	= kilo = 1000																																																																																																																																																																																																																																																								
LH	= left hand																																																																																																																																																																																																																																																								
LIN	= linear taper																																																																																																																																																																																																																																																								
LK WASH	= lock washer																																																																																																																																																																																																																																																								
LOG	= logarithmic taper																																																																																																																																																																																																																																																								
LPF	= low pass filter																																																																																																																																																																																																																																																								
m	= milli = 10 <sup>-3</sup>																																																																																																																																																																																																																																																								
M	= meg = 10 <sup>6</sup>																																																																																																																																																																																																																																																								
MET FLM	= metal film																																																																																																																																																																																																																																																								
MET OX	= metallic oxide																																																																																																																																																																																																																																																								
MFR	= manufacturer																																																																																																																																																																																																																																																								
MINAT	= miniature																																																																																																																																																																																																																																																								
MOM	= momentary																																																																																																																																																																																																																																																								
MTG	= mounting																																																																																																																																																																																																																																																								
MY	= "mylar"																																																																																																																																																																																																																																																								
n	= nano = 10 <sup>-9</sup>																																																																																																																																																																																																																																																								
N/C	= normally closed																																																																																																																																																																																																																																																								
NE	= neon																																																																																																																																																																																																																																																								
NI PL	= nickel plate																																																																																																																																																																																																																																																								
N/O	= normally open																																																																																																																																																																																																																																																								
NPO	= negative positive zero (zero temperature coefficient)																																																																																																																																																																																																																																																								
NPN	= negative-positive-negative																																																																																																																																																																																																																																																								
NRFR	= not recommended for field replacement																																																																																																																																																																																																																																																								
NSR	= not separately replaceable																																																																																																																																																																																																																																																								
OBD	= order by description																																																																																																																																																																																																																																																								
OH	= oval head																																																																																																																																																																																																																																																								
OX	= oxide																																																																																																																																																																																																																																																								
P	= peak																																																																																																																																																																																																																																																								
PC	= printed circuit																																																																																																																																																																																																																																																								
p	= pico = 10 <sup>-12</sup>																																																																																																																																																																																																																																																								
PH BRZ	= phosphor bronze																																																																																																																																																																																																																																																								
PHL	= Phillips																																																																																																																																																																																																																																																								
PIV	= peak inverse voltage																																																																																																																																																																																																																																																								
PNP	= positive-negative-positive																																																																																																																																																																																																																																																								
P/O	= part of																																																																																																																																																																																																																																																								
POLY	= polystyrene																																																																																																																																																																																																																																																								
PORC	= porcelain																																																																																																																																																																																																																																																								
POS	= position(s)																																																																																																																																																																																																																																																								
POT	= potentiometer																																																																																																																																																																																																																																																								
PP	= peak-to-peak																																																																																																																																																																																																																																																								
PT	= point																																																																																																																																																																																																																																																								
PWV	= peak working voltage																																																																																																																																																																																																																																																								
RECT	= rectifier																																																																																																																																																																																																																																																								
RF	= radio frequency																																																																																																																																																																																																																																																								
RH	= round head or right hand																																																																																																																																																																																																																																																								
RMO	= rack mount only																																																																																																																																																																																																																																																								
RMS	= root-mean square																																																																																																																																																																																																																																																								
RWV	= reverse working voltage																																																																																																																																																																																																																																																								
S-B	= slow-blow																																																																																																																																																																																																																																																								
SCR	= screw																																																																																																																																																																																																																																																								
SE	= selenium																																																																																																																																																																																																																																																								
SECT	= section(s)																																																																																																																																																																																																																																																								
SEMICON	= semiconductor																																																																																																																																																																																																																																																								
SI	= silicon																																																																																																																																																																																																																																																								
SIL	= silver																																																																																																																																																																																																																																																								
SL	= slide																																																																																																																																																																																																																																																								
SPG	= spring																																																																																																																																																																																																																																																								
SPL	= special																																																																																																																																																																																																																																																								
SST	= stainless steel																																																																																																																																																																																																																																																								
SR	= split ring																																																																																																																																																																																																																																																								
STL	= steel																																																																																																																																																																																																																																																								
TA	= tantalum																																																																																																																																																																																																																																																								
TD	= time delay																																																																																																																																																																																																																																																								
TGL	= toggle																																																																																																																																																																																																																																																								
THD	= thread																																																																																																																																																																																																																																																								
TI	= titanium																																																																																																																																																																																																																																																								
TOL	= tolerance																																																																																																																																																																																																																																																								
TRIM	= trimmer																																																																																																																																																																																																																																																								
TWT	= traveling wave tube																																																																																																																																																																																																																																																								
μ	= micro = 10 <sup>-6</sup>																																																																																																																																																																																																																																																								
VAR	= variable																																																																																																																																																																																																																																																								
VDCW	= dc working volts																																																																																																																																																																																																																																																								
W/	= with																																																																																																																																																																																																																																																								
W	= watts																																																																																																																																																																																																																																																								
WIV	= working inverse voltage																																																																																																																																																																																																																																																								
WW	= wirewound																																																																																																																																																																																																																																																								
W'O	= without																																																																																																																																																																																																																																																								

- c. A description of the part.
- d. A typical manufacturer of the part in a five-digit code.
- e. The manufacturer's number for the part.

The total quantity for each part is given only once at the first appearance of the part number in the list.

6-7. ORDERING INFORMATION.

6-8. To order a part listed in the replaceable parts table, give the Hewlett-Packard part number, indicate the quantity required, and address the order to the nearest Hewlett-Packard office.

6-9. To order a part that is not listed in the replaceable parts table, state the full instrument model and serial number, a description and the function of the part, and the number of parts required. Address your order to the nearest Hewlett-Packard office.

6-10. SPARE PARTS KIT.

6-11. Stocking spare parts for an instrument is often done to insure quick return to service after a malfunction occurs. Hewlett-Packard has a Spare Parts Kit available for this purpose. The kit consists of selected replaceable assemblies and components for this instrument. The contents of the kit and

the Recommended Spares List are based on failure reports, repair data, and parts support for one year. A complimentary Recommended Spares List for this instrument may be obtained on request and the Spare Parts Kit may be ordered through your nearest Hewlett-Packard office.

6-12. DIRECT MAIL ORDER SYSTEM.

6-13. Within the USA, Hewlett-Packard can supply parts through a direct mail order system. Advantages of using the system are:

- a. Direct ordering and shipment from the HP Parts Center in Mountain View, California.
- b. No maximum or minimum on any mail order (there is a minimum order amount for parts ordered through a local HP Office when the orders require billing and invoicing).
- c. Prepaid transportation (there is a small handling charge for each order).
- d. No invoices --- to provide these advantages, a check or money order must accompany each order.

6-14. Mail order forms and specific ordering information are available through your local HP Office. Addresses and phone numbers are located at the back of this manual.

Table 6-2. Manufacturers Code List.

MFR NO.	MANUFACTURER	ADDRESS	ZIP CODE
C0633	AKTIEBOLAGET RIFA	BROMMA SE	
00000	ANY SATISFACTORY SUPPLIER		
01121	ALLEN-BRADLEY CO	MILWAUKEE WI	53204
01295	TEXAS INSTR INC, SEMICOND CMPNT DIV	DALLAS TX	75222
01928	RCA CORP SOLID STATE DIV	SOMERVILLE NJ	08876
02111	SPECTROL ELECTRONICS CORP	CITY OF IND CA	91745
02114	FERROXCUBE CORP	SAUGERTIES NY	12477
03888	KDI PYROFILM CORP	WHIPPANY NJ	07981
04713	MOTOROLA SEMICONDUCTOR PRODUCTS	PHOENIX AZ	85062
07263	FAIRCHILD SEMICONDUCTOR DIV	MOUNTAIN VIEW CA	94042
12954	SIEMENS CORP COMPONENTS GROUP	SCOTTSDALE AZ	85252
18324	SIGNETICS CORP	SUNNYVALE CA	94086
19701	NEPCO/ELECTRA CORP	MINERAL WELLS TX	76067
24046	TRANSITRON ELECTRONIC CORP	WAKEFIELD MA	01880
24355	ANALOG DEVICES INC	NORWOOD MA	02062
24546	CORNING GLASS WORKS (BRADFORD)	BRADFORD PA	16701
27014	NATIONAL SEMICONDUCTOR CORP	SANTA CLARA CA	95051
27167	CORNING GLASS WORKS (WILMINGTON)	WILMINGTON NC	28401
28480	HEWLETT-PACKARD CO CORPORATE HQ	PALO ALTO CA	94304
30983	NEPCO/ELECTRA CORP	SAN DIEGO CA	92121
32293	INTERSIL INC	CUPERTINO CA	95014
32997	BOURNS INC TRIMPOT PROD DIV	RIVERSIDE CA	92507
34649	INTEL CORP	MOUNTAIN VIEW CA	95051
52763	STETTNER-TRUSH INC	CAZENOVIA NY	13035
56289	SPRAGUE ELECTRIC CO	NORTH ADAMS MA	01247
72136	ELECTRO MOTIVE CORP SUB IEC	WILLIMANTIC CT	06226
73138	BECKMAN INSTRUMENTS INC HELIPOT DIV	FULLERTON CA	92634
75915	LITTELFUSE INC	DES PLAINES IL	60016

Table 6-3. Replaceable Parts

Reference Designation	HP Part Number	C D	Qty	Description	Mfr Code	Mfr Part Number
A1	04274-66501	A	1	NULL DETECTOR & RANGE REGISTER BD. ASSY.	28480	04274-66501
A1C1	0180-1077	5	14	CAPACITOR-FXD 220uF +50-10% 16VDC	28480	0180-1077
A1C2	0121-0105	4	4	CAPACITOR-V TRMR-CER 9-35PF 200V PC-MTG	52763	304324 9/35PF N650
A1C3	0180-1077	5		CAPACITOR-FXD 220uF +50-10% 16VDC	28480	0180-1077
A1C5	0180-1079	7	2	CAPACITOR-FXD 2200uF +30-10% 6.3VDC	28480	0180-1079
A1C6	0180-1079	7		CAPACITOR-FXD 2200uF +30-10% 6.3VDC	28480	0180-1079
A1C7	0121-0105	4		CAPACITOR-V TRMR-CER 9-35PF 200V PC-MTG	52763	304324 9/35PF N650
A1C8	0160-2207	3	1	CAPACITOR-FXD 300PF +-5% 300VDC MICA	28480	0160-2207
A1C9	0121-0105	7	5	CAPACITOR-V TRMR-CER 9-35PF 350V PC-MTG	52763	
A1C10	0121-0036	7		CAPACITOR-V TRMR-CER 2-8PF 350V PC-MTG	52763	
A1C11	0121-0059	7		CAPACITOR-V TRMR-CER 2-8PF 350V PC-MTG	52763	304324 2/8PF NPD
A1C12	0160-2055	9	100	CAPACITOR-FXD .01UF +80-20% 100VDC CER	28480	0160-2055
A1C13	0180-1077	5		CAPACITOR-FXD 220uF +50-10% 16VDC	28480	0180-1077
A1C14	0180-1077	5		CAPACITOR-FXD 220uF +50-10% 16VDC	28480	0180-1077
A1C15	0160-3443	1	26	CAPACITOR-FXD .1UF +80-20% 50VDC CER	28480	0160-3443
A1C16	0160-3443	1		CAPACITOR-FXD .1UF +80-20% 50VDC CER	28480	0160-3443
A1C17	0160-3443	1		CAPACITOR-FXD .1UF +80-20% 50VDC CER	28480	0160-3443
A1C18	0160-3443	1		CAPACITOR-FXD .1UF +80-20% 50VDC CER	28480	0160-3443
A1C19	0160-3443	1		CAPACITOR-FXD .1UF +80-20% 50VDC CER	28480	0160-3443
A1C20	0180-1049	1	11	CAPACITOR-FXD 470uF +50-10% 16VDC	28480	0180-1049
A1C20	0180-1077	5		CAPACITOR-FXD 220uF +50-10% 16VDC	28480	0180-1077
A1C21	0180-1049	1		CAPACITOR-FXD 470uF +50-10% 16VDC	28480	0180-1049
A1C21	0180-1077	5		CAPACITOR-FXD 220uF +50-10% 16VDC	28480	0180-1077
A1C24	0160-0161	4	3	CAPACITOR-FXD .01UF +-10% 200VDC POLYE	28480	0160-0161
A1C25	0160-2218	6	1	CAPACITOR-FXD 1000PF +-5% 300VDC MICA	28480	0160-2218
A1C26	0160-2208	4	4	CAPACITOR-FXD 330PF +-5% 300VDC MICA	28480	0160-2208
A1C27	0160-2257	3	2	CAPACITOR-FXD 10PF +-5% 500VDC CER 0+-60	28480	0160-2257
A1C28	0160-2236	8	1	CAPACITOR-FXD 1PF +-25PF 500VDC CER	28480	0160-2236
A1C29	0160-3443	1		CAPACITOR-FXD .1UF +80-20% 50VDC CER	28480	0160-3443
A1C30	0160-3443	1		CAPACITOR-FXD .1UF +80-20% 50VDC CER	28480	0160-3443
A1C31	0160-3443	1		CAPACITOR-FXD .1UF +80-20% 50VDC CER	28480	0160-3443
A1C32	0160-3443	1		CAPACITOR-FXD .1UF +80-20% 50VDC CER	28480	0160-3443
A1C33	0140-0199	0	1	CAPACITOR-FXD 240PF +-5% 300VDC MICA	72136	DM15F241J0300WV1CR
A1C35	0180-1085	5	39	CAPACITOR-FXD 4.7uF +-20% 16VDC	28480	0180-1085
A1C36	0180-1085	5		CAPACITOR-FXD 4.7uF +-20% 16VDC	28480	0180-1085
A1C37	0180-1077	5		CAPACITOR-FXD 220uF +50-10% 16VDC	28480	0180-1077
A1C38	0180-1077	5		CAPACITOR-FXD 220uF +50-10% 16VDC	28480	0180-1077
A1C39	0140-0196	3	1	CAPACITOR-FXD 150PF +-5% 300VDC MICA	72136	DM15F151J0300WV1CR
A1C40	0160-2222	2	1	CAPACITOR-FXD 1500PF +-5% 300VDC MICA	28480	0160-2222
A1C41	0160-0301	4	1	CAPACITOR-FXD .012UF +-10% 200VDC POLYE	28480	0160-0301
A1C42	0160-2055	9		CAPACITOR-FXD .01UF +80-20% 100VDC CER	28480	0160-2055
A1C43	0160-2055	9		CAPACITOR-FXD .01UF +80-20% 100VDC CER	28480	0160-2055
A1C44	0160-2055	9		CAPACITOR-FXD .01UF +80-20% 100VDC CER	28480	0160-2055
A1C45	0160-1085	5		CAPACITOR-FXD 4.7uF +-20% 16VDC	28480	0160-1085
A1C46	0180-1085	5		CAPACITOR-FXD 4.7uF +-20% 16VDC	28480	0180-1085
A1C47	0160-2055	9		CAPACITOR-FXD .01UF +80-20% 100VDC CER	28480	0160-2055
A1C48	0160-2055	9		CAPACITOR-FXD .01UF +80-20% 100VDC CER	28480	0160-2055
A1C49	0160-3443	1		CAPACITOR-FXD .1UF +80-20% 50VDC CER	28480	0160-3443
A1C50	0160-3443	1		CAPACITOR-FXD .1UF +80-20% 50VDC CER	28480	0160-3443
A1C51	0160-3443	1		CAPACITOR-FXD .1UF +80-20% 50VDC CER	28480	0160-3443
A1C52	0160-3443	1		CAPACITOR-FXD .1UF +80-20% 50VDC CER	28480	0160-3443
A1C53	0160-3443	1		CAPACITOR-FXD .1UF +80-20% 50VDC CER	28480	0160-3443
A1C54	0160-3443	1		CAPACITOR-FXD .1UF +80-20% 50VDC CER	28480	0160-3443
A1C55	0160-3443	1		CAPACITOR-FXD .1UF +80-20% 50VDC CER	28480	0160-3443
A1C56	0180-1085	5		CAPACITOR-FXD 4.7uF +-20% 16VDC	28480	0180-1085
A1C57	0180-1085	5		CAPACITOR-FXD 4.7uF +-20% 16VDC	28480	0180-1085
A1C58	0180-1083	6	14	CAPACITOR-FXD 33UF -10+75% 25WVDC TA	56289	
A1C59	0180-1083	6		CAPACITOR-FXD 33UF -10+75% 25WVDC TA	56289	
A1C60	0180-1049	1		CAPACITOR-FXD 470uF +50-10% 16VDC	28480	0180-1049
A1C61	0180-1049	1		CAPACITOR-FXD 470uF +50-10% 16VDC	28480	0180-1049
A1C62	0160-1085	5		CAPACITOR-FXD 4.7uF +-20% 16VDC	28480	0160-1085
A1C63	0160-3443	1		CAPACITOR-FXD .1UF +80-20% 50VDC CER	28480	0160-3443
A1C64	0160-3443	1		CAPACITOR-FXD .1UF +80-20% 50VDC CER	28480	0160-3443
A1C65	0180-1085	5		CAPACITOR-FXD 4.7uF +-20% 16VDC	28480	0180-1085
A1C66	0160-1085	5		CAPACITOR-FXD 4.7uF +-20% 16VDC	28480	0160-1085
A1C67	0180-1049	1		CAPACITOR-FXD 470uF +50-10% 16VDC	28480	0180-1049
A1C68	0180-1085	5		CAPACITOR-FXD 4.7uF +-20% 16VDC	28480	0180-1085
A1C69	0160-1085	5		CAPACITOR-FXD 4.7uF +-20% 16VDC	28480	0160-1085
A1C70	0180-1086	6	2	CAPACITOR 33uF +50-30% 16VDC	28480	0180-1086
A1C81	0180-2141	0	3	CAPACITOR-FXD 3.3UF +-10% 50VDC TA	56289	150D335X905082
A1C82	0180-1086	6		CAPACITOR 33uF +50-30% 16VDC	28480	0180-1086
A1CR1	1901-0029	6	10	DIODE-PWR RECT 600V 750MA DO-29	28480	1901-0029
A1CR2	1901-0029	6		DIODE-PWR RECT 600V 750MA DO-29	28480	1901-0029
A1CR3	1901-0029	6		DIODE-PWR RECT 600V 750MA DO-29	28480	1901-0029
A1CR4	1901-0029	6		DIODE-PWR RECT 600V 750MA DO-29	28480	1901-0029
A1CR5	1901-0029	6		DIODE-PWR RECT 600V 750MA DO-29	28480	1901-0029

See introduction to this section for ordering information  
\*Indicates factory selected value

Table 6-3. Replaceable Parts (Cont'd).

Reference Designation	HP Part Number	C D	Qty	Description	Mfr Code	Mfr Part Number
A1CR6	1901-0029	6	47	DIODE-PWR RECT 600V 750MA DO-29	28480	1901-0029
A1CR7	1901-0025	2		DIODE-GEN PRP 100V 200MA DO-7	28480	1901-0025
A1CR8	1901-0025	2		DIODE-GEN PRP 100V 200MA DO-7	28480	1901-0025
A1CR9	1901-0025	2		DIODE-GEN PRP 100V 200MA DO-7	28480	1901-0025
A1CR10	1901-0025	2		DIODE-GEN PRP 100V 200MA DO-7	28480	1901-0025
A1CR11	1901-0025	2		DIODE-GEN PRP 100V 200MA DO-7	28480	1901-0025
A1CR12	1901-0025	2		DIODE-GEN PRP 100V 200MA DO-7	28480	1901-0025
A1CR13	1901-0029	6		DIODE-PWR RECT 600V 750MA DO-29	28480	1901-0029
A1CR14	1901-0029	6		DIODE-PWR RECT 600V 750MA DO-29	28480	1901-0029
A1CR15	1901-0029	6		DIODE-PWR RECT 600V 750MA DO-29	28480	1901-0029
A1CR16	1901-0029	6	18	DIODE-PWR RECT 600V 750MA DO-29	28480	1901-0029
A1CR17	1901-0033	2		DIODE-GEN PRP 180V 200MA DO-7	28480	1901-0033
A1CR18	1901-0033	2		DIODE-GEN PRP 180V 200MA DO-7	28480	1901-0033
A1CR19	1902-3082	9		DIODE-ZNR 4.64V 5% DO-7 PD=.4W TC=-.023%	28480	1902-3082
A1CR20	1902-3160	4		DIODE-ZNR 10V 2% DO-7 PD=.4W TC=+.06%	28480	1902-3160
A1CR21	1901-0040	1	56	DIODE-SWITCHING 30V 50MA 2NS DO-35	28480	1901-0040
A1CR22	1901-0040	1		DIODE-SWITCHING 30V 50MA 2NS DO-35	28480	1901-0040
A1CR23	1901-0040	1		DIODE-SWITCHING 30V 50MA 2NS DO-35	28480	1901-0040
A1CR24	1901-0040	1		DIODE-SWITCHING 30V 50MA 2NS DO-35	28480	1901-0040
A1CR25	1902-3149	9		DIODE-ZNR 9.09V 5% DO-7 PD=.4W TC=+.057%	28480	1902-3149
A1CR26	1902-3160	4		DIODE-ZNR 10V 2% DO-7 PD=.4W TC=+.06%	28480	1902-3160
A1CR27	1901-0025	2		DIODE-GEN PRP 100V 200MA DO-7	28480	1901-0025
A1CR28	1902-3082	9		DIODE-ZNR 4.64V 5% DO-7 PD=.4W TC=-.023%	28480	1902-3082
A1CR29	1901-0040	1		DIODE-SWITCHING 30V 50MA 2NS DO-35	28480	1901-0040
A1CR30	1901-0040	1		DIODE-SWITCHING 30V 50MA 2NS DO-35	28480	1901-0040
A1CR31	1902-3036	3	6	DIODE-ZNR 3.16V 5% DO-7 PD=.4W TC=-.064%	28480	1902-3036
A1CR32	1902-3036	3		DIODE-ZNR 3.16V 5% DO-7 PD=.4W TC=-.064%	28480	1902-3036
A1CR33	1901-0025	2		DIODE-GEN PRP 100V 200MA DO-7	28480	1901-0025
A1CR34	1901-0025	2		DIODE-GEN PRP 100V 200MA DO-7	28480	1901-0025
A1CR35	1901-0033	2		DIODE-GEN PRP 180V 200MA DO-7	28480	1901-0033
A1CR36	1901-0033	2		DIODE-GEN PRP 180V 200MA DO-7	28480	1901-0033
A1J1	1250-0257	1	5	CONNECTOR-RF SMB M PC 50-OHM	28480	1250-0257
A1J2	1250-0257	1		CONNECTOR-RF SMB M PC 50-OHM	28480	1250-0257
A1J3	1250-0257	1		CONNECTOR-RF SMB M PC 50-OHM	28480	1250-0257
A1J4	1250-0257	1		CONNECTOR-RF SMB M PC 50-OHM	28480	1250-0257
A1J5	1250-0257	1		CONNECTOR-RF SMB M PC 50-OHM	28480	1250-0257
A1K1	0490-0237	4	2	RELAY-REED 2A	28480	0490-0237
A1K2	0490-0237	4		RELAY-REED 2A	28480	0490-0237
A1K3	0490-0239	6		RELAY-REED 2A	28480	0490-0239
A1K4	0490-1269	1		RELAY, REED	28480	
A1K5	0490-1269	1		RELAY, REED	28480	
A1K6	0490-1269	1		RELAY, REED	28480	
A1K7	0490-1269	1		RELAY, REED	28480	
A1K8	0490-1269	1		RELAY, REED	28480	
A1K9	0490-1269	1		RELAY, REED	28480	
A1K10	0490-1269	1		RELAY, REED	28480	
A1K11	0490-0240	9	5	RELAY-REED 1A	28480	0490-0240
A1K12	0490-0240	9		RELAY-REED 1A	28480	0490-0240
A1K13	0490-0240	9		RELAY-REED 1A	28480	0490-0240
A1K14	0490-0240	9		RELAY-REED 1A	28480	0490-0240
A1L1	9140-0210	1	2	COIL-MLD 100UH 5% Q=50 .155Dx.375LG-NOM	28480	9140-0210
A1L2	9140-0210	1		COIL-MLD 100UH 5% Q=50 .155Dx.375LG-NOM	28480	9140-0210
A1Q1	1854-0071	7	23	TRANSISTOR NPN SI PD=300MW FT=200MHZ	28480	1854-0071
A1Q2	1854-0071	7		TRANSISTOR NPN SI PD=300MW FT=200MHZ	28480	1854-0071
A1Q3	1854-0071	7		TRANSISTOR NPN SI PD=300MW FT=200MHZ	28480	1854-0071
A1Q4	1854-0071	7		TRANSISTOR NPN SI PD=300MW FT=200MHZ	28480	1854-0071
A1Q5	1854-0071	7		TRANSISTOR NPN SI PD=300MW FT=200MHZ	28480	1854-0071
A1Q6	1854-0071	7		TRANSISTOR NPN SI PD=300MW FT=200MHZ	28480	1854-0071
A1Q7	1854-0071	7		TRANSISTOR NPN SI PD=300MW FT=200MHZ	28480	1854-0071
A1Q8	1854-0071	7		TRANSISTOR NPN SI PD=300MW FT=200MHZ	28480	1854-0071
A1Q9	1854-0071	7		TRANSISTOR NPN SI PD=300MW FT=200MHZ	28480	1854-0071
A1Q10	1854-0071	7		TRANSISTOR NPN SI PD=300MW FT=200MHZ	28480	1854-0071
A1Q11	1854-0071	7		TRANSISTOR NPN SI PD=300MW FT=200MHZ	28480	1854-0071
A1Q12	1854-0071	7		TRANSISTOR NPN SI PD=300MW FT=200MHZ	28480	1854-0071
A1Q13	1854-0071	7		TRANSISTOR NPN SI PD=300MW FT=200MHZ	28480	1854-0071
A1Q14	1855-0049	1		TRANSISTOR-JFET DUAL N-CHAN O-MODE SI	28480	1855-0049
A1Q15	1854-0039	7		TRANSISTOR NPN 2N3053B SI TO-39 PD=1W	01928	2N3053B
A1Q16	1853-0012	4	3	TRANSISTOR PNP 2N2904A SI TO-39 PD=600MW	01295	2N2904A
A1Q17	1854-0129	6		TRANSISTOR NPN SI	28480	1854-0129
A1Q18	1854-0129	6		TRANSISTOR NPN SI	28480	1854-0129
A1Q19	1854-0129	6	5	TRANSISTOR NPN SI	28480	1854-0129
A1Q20	1853-0020	4		TRANSISTOR PNP SI PD=300MW FT=150MHZ	28480	1853-0020
A1Q21	1854-0129	6		TRANSISTOR NPN SI	28480	1854-0129
A1Q22	1854-0129	6		TRANSISTOR NPN SI	28480	1854-0129
A1Q23	1853-0020	7		TRANSISTOR PNP SI PD=300MW FT=150MHZ	28480	1853-0020
A1Q24	1854-0071	4		TRANSISTOR NPN SI PD=300MW FT=200MHZ	28480	1854-0071
A1Q25	1855-0261	9		TRANSISTOR MOS-FET	28480	1855-0261

See introduction to this section for ordering information  
\*Indicates factory selected value

Table 6-3. Replaceable Parts (Cont'd).

Reference Designation	HP Part Number	C D	Qty	Description	Mfr Code	Mfr Part Number
A1R1	2100-2574	3	1	RESISTOR-TRMR 500 10% C SIDE-ADJ 1-TRN	30983	ET50X501
A1R2	0757-0394	0	2	RESISTOR 51.1 1% .125W F TC=0+-100	24546	C4=1/8-T0-51R1-F
A1R3	0698-4433	0	1	RESISTOR 2.26K 1% .125W F TC=0+-100	24546	C4=1/8-T0-2261-F
A1R4	0757-0280	3	12	RESISTOR 1K 1% .125W F TC=0+-100	24546	C4=1/8-T0-1001-F
A1R5	0683-7515	4	2	RESISTOR 750 5% .25W FC TC=400/+600	01121	CB7515
A1R6	0683-7515	4		RESISTOR 750 5% .25W FC TC=400/+600	01121	CB7515
A1R7	0757-0442	9	28	RESISTOR 10K 1% .125W F TC=0+-100	24546	C4=1/8-T0-1002-F
A1R8	2100-3273	1	2	RESISTOR-TRMR 2K 10% C SIDE-ADJ 1-TRN	28480	2100-3273
A1R9	0757-0418	9	1	RESISTOR 619 1% .125W F TC=0+-100	24546	C4=1/8-T0-619R-F
A1R10	0698-2337	9	2	RESISTOR 20.2 +- .5% .5W	28480	0698-2337
A1R11	0698-2337	9		RESISTOR 20.2 +- .5% .5W	28480	0698-2337
A1R12	2100-3274	2	7	RESISTOR-TRMR 10K 10% C SIDE-ADJ 1-TRN	28480	2100-3274
A1R13	0757-0440	7	10	RESISTOR 7.5K 1% .125W F TC=0+-100	24546	C4=1/8-T0-7501-F
A1R14	0698-2316	4	1	RESISTOR, FXD MET FLM 101.3 OHM 0.1% 1/8		
A1R15	2100-3426	6	6	RESISTOR-TRMR 20 10% C SIDE-ADJ 1-TRN	28480	2100-3426
A1R16	0757-0394	0		RESISTOR 51.1 1% .125W F TC=0+-100	24546	C4=1/8-T0-51R1-F
A1R17	0698-2338	0	1	RESISTOR-FXD 950 +- .1% .125W	28480	0698-2338
A1R18	2100-3350	5	1	RESISTOR-TRMR 200 10% C SIDE-ADJ 1-TRN	28480	2100-3350
A1R19	0757-0416	7	4	RESISTOR 511 1% .125W F TC=0+-100	24546	C4=1/8-T0-511R-F
A1R20	0698-2339	1	1	RESISTOR-FXD 10.5k +- .1% .125W	28480	0698-2339
A1R21	2100-3273	1		RESISTOR-TRMR 2K 10% C SIDE-ADJ 1-TRN	28480	2100-3273
A1R22	0698-3154	0	6	RESISTOR 4.22K 1% .125W F TC=0+-100	24546	C4=1/8-T0-4221-F
A1R23	0698-2340	4	1	RESISTOR-FXD 95k +- .1% .125W	28480	0698-2340
A1R24	0757-0346	2	2	RESISTOR 10 1% .125W F TC=0+-100	24546	C4=1/8-T0-10R0-F
A1R25	0683-4725	2	49	RESISTOR 4.7K 5% .25W FC TC=400/+700	01121	CB4725
A1R26	0683-4725	2		RESISTOR 4.7K 5% .25W FC TC=400/+700	01121	CB4725
A1R27	0683-4725	2		RESISTOR 4.7K 5% .25W FC TC=400/+700	01121	CB4725
A1R28	0683-4725	2		RESISTOR 4.7K 5% .25W FC TC=400/+700	01121	CB4725
A1R29	0683-4725	2		RESISTOR 4.7K 5% .25W FC TC=400/+700	01121	CB4725
A1R30	0683-4725	2		RESISTOR 4.7K 5% .25W FC TC=400/+700	01121	CB4725
A1R31	0757-0346	2		RESISTOR 10 1% .125W F TC=0+-100	24546	C4=1/8-T0-10R0-F
A1R32	0757-0401	0	3	RESISTOR 100 1% .125W F TC=0+-100	24546	C4=1/8-T0-101-F
A1R33	0757-0280	3		RESISTOR 1K 1% .125W F TC=0+-100	24546	C4=1/8-T0-1001-F
A1R34	0757-0442	9		RESISTOR 10K 1% .125W F TC=0+-100	24546	C4=1/8-T0-1002-F
A1R35	0757-0465	6	9	RESISTOR 100K 1% .125W F TC=0+-100	24546	C4=1/8-T0-1003-F
A1R36	0683-1035	1	40	RESISTOR 10K 5% .25W FC TC=400/+700	01121	CB1035
A1R37	0683-1035	1		RESISTOR 10K 5% .25W FC TC=400/+700	01121	CB1035
A1R38	0683-1035	1		RESISTOR 10K 5% .25W FC TC=400/+700	01121	CB1035
A1R39	0683-1035	1		RESISTOR 10K 5% .25W FC TC=400/+700	01121	CB1035
A1R40	0757-0280	3		RESISTOR 1K 1% .125W F TC=0+-100	24546	C4=1/8-T0-1001-F
A1R41	0683-4715	0	7	RESISTOR 470 5% .25W FC TC=400/+600	01121	CB4715
A1R42	2100-1788	9	1	RESISTOR-TRMR 500 10% C TOP-ADJ 1-TRN	73138	82PR500
A1R43	0698-0084	9	8	RESISTOR 2.15K 1% .125W F TC=0+-100	24546	C4=1/8-T0-2151-F
A1R44	0698-0084	9		RESISTOR 2.15K 1% .125W F TC=0+-100	24546	C4=1/8-T0-2151-F
A1R45	0698-0083	8	3	RESISTOR 1.96k 1% .125W F TC=0+-100	24546	C4=1/8-T0-1961-F
A1R46	0757-0460	1	1	RESISTOR 61.9K 1% .125W F TC=0+-100	24546	C4=1/8-T0-6192-F
A1R47	0698-0083	8		RESISTOR 1.96k 1% .125W F TC=0+-100	24546	C4=1/8-T0-1961-F
A1R48	0683-4725	2		RESISTOR 4.7K 5% .25W FC TC=400/+700	01121	CB4725
A1R49	0683-1515	2	8	RESISTOR 150 5% .25W FC TC=400/+600	01121	CB1515
A1R50	0683-4705	8	17	RESISTOR 47 5% .25W FC TC=400/+500	01121	CB4705
A1R51	0683-4725	2		RESISTOR 4.7K 5% .25W FC TC=400/+700	01121	CB4725
A1R52	0683-1005	5	17	RESISTOR 10 5% .25W FC TC=400/+500	01121	CB1005
A1R53	0683-1005	5		RESISTOR 10 5% .25W FC TC=400/+500	01121	CB1005
A1R54	0683-4705	8		RESISTOR 47 5% .25W FC TC=400/+500	01121	CB4705
A1R55	0683-2205	9	4	RESISTOR 22 5% .25W FC TC=400/+500	01121	CB2205
A1R56	0683-2205	9		RESISTOR 22 5% .25W FC TC=400/+500	01121	CB2205
A1R57	0757-0280	3		RESISTOR 1K 1% .125W F TC=0+-100	24546	C4=1/8-T0-1001-F
A1R58	0683-1035	1		RESISTOR 10K 5% .25W FC TC=400/+700	01121	CB1035
A1R59	0683-1035	1		RESISTOR 10K 5% .25W FC TC=400/+700	01121	CB1035
A1R60	0683-2235	5	24	RESISTOR 22K 5% .25W FC TC=400/+800	01121	CB2235
A1R61	0683-2235	5		RESISTOR 22K 5% .25W FC TC=400/+800	01121	CB2235
A1R62	0683-2235	5		RESISTOR 22K 5% .25W FC TC=400/+800	01121	CB2235
A1R63	0683-2235	5		RESISTOR 22K 5% .25W FC TC=400/+800	01121	CB2235
A1R64	0683-1035	1		RESISTOR 10K 5% .25W FC TC=400/+700	01121	CB1035
A1R65	0698-3400	7	3	RESISTOR 196 1% .125W F TC=0+-100	24546	C4=1/8-T0-196R-F
A1R66	2100-2216	0	1	RESISTOR-TRMR 5K 10% C TOP-ADJ 1-TRN	73138	82PR5K
A1R67	0757-0279	0	8	RESISTOR 3.16K 1% .125W F TC=0+-100	24546	C4=1/8-T0-3161-F
A1R68	0698-4455	6	1	RESISTOR 536 1% .125W F TC=0+-100	24546	C4=1/8-T0-536R-F
A1R69	0757-0290	5	1	RESISTOR 6.19K 1% .125W F TC=0+-100	19701	MF4C1/8-T0-6191-F
A1R70	0683-4715	0		RESISTOR 470 5% .25W FC TC=400/+600	01121	CB4715
A1R71	0683-1035	1		RESISTOR 10K 5% .25W FC TC=400/+700	01121	CB1035
A1R72	0683-1035	1		RESISTOR 10K 5% .25W FC TC=400/+700	01121	CB1035
A1R73	0683-1035	1		RESISTOR 10K 5% .25W FC TC=400/+700	01121	CB1035
A1R74	0683-1035	1		RESISTOR 10K 5% .25W FC TC=400/+700	01121	CB1035
A1R75	0698-3154	0		RESISTOR 4.22K 1% .125W F TC=0+-100	24546	C4=1/8-T0-4221-F

See introduction to this section for ordering information  
\*Indicates factory selected value

Table 6-3. Replaceable Parts (Cont'd).

Reference Designation	HP Part Number	C D	Qty	Description	Mfr Code	Mfr Part Number
A1R76	0757-0280	3		RESISTOR 1K 1% .125W F TC=0+/-100	24546	C4-1/8-T0-1001-F
A1R77	0757-0416	7		RESISTOR 511 1% .125W F TC=0+/-100	24546	C4-1/8-T0-511R-F
A1R78	0757-0416	7		RESISTOR 511 1% .125W F TC=0+/-100	24546	C4-1/8-T0-511R-F
A1R79	0698-3450	9	5	RESISTOR 42.2K 1% .125W F TC=0+/-100	24546	C4-1/8-T0-4222-F
A1R80	0683-2225	3	18	RESISTOR 2.2K 5% .25W FC TC=-400/+700	01121	CB2225
A1R81	0683-3335	8	18	RESISTOR 33K 5% .25W FC TC=-400/+800	01121	CB3335
A1R82	0757-0442	9		RESISTOR 10K 1% .125W F TC=0+/-100	24546	C4-1/8-T0-1002-F
A1R83	0757-0442	9		RESISTOR 10K 1% .125W F TC=0+/-100	24546	C4-1/8-T0-1002-F
A1R84	0757-0279	0		RESISTOR 3.16K 1% .125W F TC=0+/-100	24546	C4-1/8-T0-3161-F
A1R85	0683-1005	5		RESISTOR 10 5% .25W FC TC=-400/+500	01121	CB1005
A1R86	0683-1005	5		RESISTOR 10 5% .25W FC TC=-400/+500	01121	CB1005
A1R87	0757-0442	9		RESISTOR 10K 1% .125W F TC=0+/-100	24546	C4-1/8-T0-1002-F
A1R88	0757-0416	7		RESISTOR 511 1% .125W F TC=0+/-100	24546	C4-1/8-T0-511R-F
A1R89	0698-3540	8	1	RESISTOR 15.4K 1% .125W F TC=0+/-100	24546	C4-1/8-T0-1542-F
A1R90	0683-4725	2		RESISTOR 4.7K 5% .25W FC TC=-400/+700	01121	CB4725
A1R91	0683-1005	5		RESISTOR 10 5% .25W FC TC=-400/+500	01121	CB1005
A1R92	0683-1005	5		RESISTOR 10 5% .25W FC TC=-400/+500	01121	CB1005
A1R93	0683-4725	2		RESISTOR 4.7K 5% .25W FC TC=-400/+700	01121	CB4725
A1R94	0683-4705	8		RESISTOR 47 5% .25W FC TC=-400/+500	01121	CB4705
A1R95	0683-1015	7	17	RESISTOR 100 5% .25W FC TC=-400/+500	01121	CB1015
A1R96	0683-1015	7		RESISTOR 100 5% .25W FC TC=-400/+500	01121	CB1015
A1R97	0683-4705	8		RESISTOR 47 5% .25W FC TC=-400/+500	01121	CB4705
A1R98	0698-3245	0	2	RESISTOR 20.5K 1% .125W F TC=0+/-100	24546	C4-1/8-T0-2052-F
A1R99	0757-0274	5	5	RESISTOR 1.21K 1% .125W F TC=0+/-100	24546	C4-1/8-T0-1213-F
A1R100	0757-0274	5	5	RESISTOR 1.21K 1% .125W F TC=0+/-100	24546	C4-1/8-T0-1213-F
A1R101	0757-0274	5		RESISTOR 1.21K 1% .125W F TC=0+/-100	24546	C4-1/8-T0-1213-F
A1R102	0757-0274	5		RESISTOR 1.21K 1% .125W F TC=0+/-100	24546	C4-1/8-T0-1213-F
A1R103	0698-3245	0		RESISTOR 20.5K 1% .125W F TC=0+/-100	24546	C4-1/8-T0-2052-F
A1R104	1R10-0205	7	12	NETWORK-RES 8-PIN-SIP .1-PIN-SPCG	01121	2084472
A1R150	0698-3155	1	21	RESISTOR 4.64K 1% .125W F TC=0+/-100	24546	C4-1/8-T0-4641-F
A1R151	0683-1025	9	10	RESISTOR 1K 5% .25W FC TC=-400/+600	01121	CB1025
A1T1	9100-0874	9	1	TRANSFORMER-SIGNAL	28480	9100-0874
A1T2	9100-0878	3	3	TRANSFORMER-SIGNAL	28480	9100-0878
A1U1	1R26-0357	3	4	OP AMP WB T0-99	27014	LF357H
A1U2	1R26-0319	7	18	OP AMP BIFET T0-99	27014	LF356H
A1U3	1R26-0319	7		OP AMP BIFET T0-99	27014	LF356H
A1U4	1R26-0319	7		OP AMP BIFET T0-99	27014	LF356H
A1U5	1R26-0138	8	11	COMPARATOR GP QUAD 14-DIP-P	04713	MLM339P
A1U6	1R26-0319	7		OP AMP BIFET T0-99	27014	LF356H
A1U7	1R26-0081	0	14	OP AMP WB T0-99	27014	LM318H
A1U8	1R20-0203	6	3	OP AMP GP T0-99	01928	CA741CT
				A1 MISCELLANEOUS PARTS		
	04074-26501	2	1	PC BOARD, BLANK	28480	04074-26501
A2	04274-66502	9	1	MODULATOR BOARD ASSEMBLY	28480	04274-66502
A2C1	0180-0197	8	11	CAPACITOR-FXD 2.2UF +/-10% 20VDC TA	56289	150D225X9020A2
A2C2	0150-0121	5	49	CAPACITOR-FXD .1UF +80-20% 50VDC CER	28480	0150-0121
A2C3	0150-0121	5		CAPACITOR-FXD .1UF +80-20% 50VDC CER	28480	0150-0121
A2C4	0160-1603	1	3	CIFXD MY 1 UF 10% 100VDC#	28480	0160-1603
A2C5	0180-1061	7	7	CAPACITOR-FXD 220uF +50-10% 16VDC	28480	0180-1061
A2C6	0180-0374	3	8	CAPACITOR-FXD 10UF +/-10% 20VDC TA	56289	150D106X9020B2
A2C7	0150-0121	5		CAPACITOR-FXD .1UF +80-20% 50VDC CER	28480	0150-0121
A2C8	0150-0121	5		CAPACITOR-FXD .1UF +80-20% 50VDC CER	28480	0150-0121
A2C9	0160-2940	1	6	CAPACITOR-FXD 470PF +/-5% 300VDC MICA	28480	0160-2940
A2C10	0160-2940	1		CAPACITOR-FXD 470PF +/-5% 300VDC MICA	28480	0160-2940
A2C11	0180-1061	7		CAPACITOR-FXD 220uF +50-10% 16VDC	28480	0180-1061
A2C12	0180-0374	3		CAPACITOR-FXD 10UF +/-10% 20VDC TA	56289	150D106X9020B2
A2C13	0150-0121	5		CAPACITOR-FXD .1UF +80-20% 50VDC CER	28480	0150-0121
A2C14	0150-0121	5		CAPACITOR-FXD .1UF +80-20% 50VDC CER	28480	0150-0121
A2C15	0160-2940	1		CAPACITOR-FXD 470PF +/-5% 300VDC MICA	28480	0160-2940
A2C16	0160-2940	1		CAPACITOR-FXD 470PF +/-5% 300VDC MICA	28480	0160-2940
A2C17	0150-0121	5		CAPACITOR-FXD .1UF +80-20% 50VDC CER	28480	0150-0121
A2C18	0150-0121	5		CAPACITOR-FXD .1UF +80-20% 50VDC CER	28480	0150-0121
A2C19	0160-0134	1	6	CAPACITOR-FXD 220PF +/-5% 300VDC MICA	28480	0160-0134
A2C20	0160-0134	1		CAPACITOR-FXD 220PF +/-5% 300VDC MICA	28480	0160-0134
A2C20	0160-1603	1		CIFXD MY 1 UF 10% 100VDC#	28480	0160-1603
A2C22	0160-1603	1		CIFXD MY 1 UF 10% 100VDC#	28480	0160-1603
A2C23	0150-0121	5		CAPACITOR-FXD .1UF +80-20% 50VDC CER	28480	0150-0121
A2C25	0150-0121	5		CAPACITOR-FXD .1UF +80-20% 50VDC CER	28480	0150-0121
A2C27	0150-0121	5		CAPACITOR-FXD .1UF +80-20% 50VDC CER	28480	0150-0121
A2C28	0160-1685	9	2	CAPACITOR 2.2UF +/-10% 100VDC	28480	0160-1685

See introduction to this section for ordering information  
\*Indicates factory selected value

Table 6-3. Replaceable Parts (Cont'd).

Reference Designation	HP Part Number	C D	Qty	Description	Mfr Code	Mfr Part Number
A2C30	0150-0121	5		CAPACITOR-FXD .1UF +80-20% 50VDC CER	28480	0150-0121
A2C31	0160-1685	9		CAPACITOR 2.2UF +-10% 100VDC	28480	0160-1685
A2C32	0160-0970	3	1	CAPACITOR-FXD .47UF +-10% 80VDC POLYE	28480	0160-0970
A2C33	0160-0166	6		CAPACITOR-FXD .068UF +-10% 200VDC POLYE	28480	
A2C34	0160-0159	3	1	CAPACITOR-FXD 6800PF +-10% 200VDC POLYE	28480	
A2C35	0160-0153	8	1	CAPACITOR-FXD 1000PF +-10% 200VDC POLYE	28480	
A2C36	0160-0374	3		CAPACITOR-FXD 10UF+-10% 20VDC TA	56289	150D106X9020B2
A2C37	0160-0374	3		CAPACITOR-FXD 10UF+-10% 20VDC TA	56289	150D106X9020B2
A2C38	0160-1061	7		CAPACITOR-FXD 220UF +50-10% 16VDC	28480	0180-1061
A2C39	0160-1061	7		CAPACITOR-FXD 220UF +50-10% 16VDC	28480	0180-1061
A2C40	0150-0121	5		CAPACITOR-FXD .1UF +80-20% 50VDC CER	28480	0150-0121
A2C41	0150-0121	5		CAPACITOR-FXD .1UF +80-20% 50VDC CER	28480	0150-0121
A2C42	0160-2306	3	1	CAPACITOR-FXD 27PF +-5% 300VDC MICA	28480	0160-2306
A2C43	0160-0197	6		CAPACITOR-FXD 2.2UF+-10% 20VDC TA	56289	150D225X9020A2
A2C44	0160-0127	2	12	CAPACITOR-FXD 1UF +-20% 25VDC CER	28480	0160-0127
A2C45	0160-0127	2		CAPACITOR-FXD 1UF +-20% 25VDC CER	28480	0160-0127
A2C46	0160-0197	8		CAPACITOR-FXD 2.2UF+-10% 20VDC TA	56289	150D225X9020A2
A2C47	0160-0127	2		CAPACITOR-FXD 1UF +-20% 25VDC CER	28480	0160-0127
A2C48	0160-0127	2		CAPACITOR-FXD 1UF +-20% 25VDC CER	28480	0160-0127
A2C49	0150-0121	5		CAPACITOR-FXD .1UF +80-20% 50VDC CER	28480	0150-0121
A2C50	0150-0121	5		CAPACITOR-FXD .1UF +80-20% 50VDC CER	28480	0150-0121
A2C51	0160-0374	3		CAPACITOR-FXD 10UF+-10% 20VDC TA	56289	150D106X9020B2
A2C52	0160-0229	7	2	CAPACITOR-FXD 33UF+-10% 10VDC TA	56289	150D336X9010B2
A2CR1	1901-0040	1		DIODE-SWITCHING 30V 50MA 2NS DO-35	28480	1901-0040
A2CR2	1902-3036	3		DIODE-ZNR 3.16V 5% DO-7 PD=.4W TC=-.064X	28480	1902-3036
A2CR3	1902-3036	3		DIODE-ZNR 3.16V 5% DO-7 PD=.4W TC=-.064X	28480	1902-3036
A2CR4	1902-3036	3		DIODE-ZNR 3.16V 5% DO-7 PD=.4W TC=-.064X	28480	1902-3036
A2CR5	1902-3036	3		DIODE-ZNR 3.16V 5% DO-7 PD=.4W TC=-.064X	28480	1902-3036
A2CR25 ~ 28	1901-0040			DIODE-SWITCHING		
A2Q1	1854-0071	7		TRANSISTOR NPN SI PD=300MW FT=200MHZ	28480	1854-0071
A2Q2	1855-0091	3	10	TRANSISTOR JFET N-CHAN D-MODE SI	28480	1855-0091
A2Q3	1855-0091	3		TRANSISTOR JFET N-CHAN D-MODE SI	28480	1855-0091
A2Q4	1854-0071	7		TRANSISTOR NPN SI PD=300MW FT=200MHZ	28480	1854-0071
A2Q5	1854-0071	7		TRANSISTOR NPN SI PD=300MW FT=200MHZ	28480	1854-0071
A2Q6	1854-0071	7		TRANSISTOR NPN SI PD=300MW FT=200MHZ	28480	1854-0071
A2Q7	1854-0071	7		TRANSISTOR NPN SI PD=300MW FT=200MHZ	28480	1854-0071
A2Q8	1854-0071	7		TRANSISTOR NPN SI PD=300MW FT=200MHZ	28480	1854-0071
A2Q9	1854-0071	7		TRANSISTOR NPN SI PD=300MW FT=200MHZ	28480	1854-0071
A2Q10	1854-0448	2	3	TRANSISTOR NPN SI TO-39 PD=1W FT=100MHZ	28480	1854-0448
A2Q11	1853-0020	4		TRANSISTOR PNP SI PD=300MW FT=150MHZ	28480	1853-0020
A2Q12	1853-0027	1	3	TRANSISTOR PNP SI TO-39 PD=1W FT=100MHZ	28480	1853-0027
A2R1	2100-3161	6	2	RESISTOR-TMR 20K 10% C SIDE-ADJ 17-TRN	02111	43P203
A2R2	0683-4725	2		RESISTOR 4.7K 5% .25W FC TC=-400/+700	01121	C84725
A2R3	0683-3325	6	21	RESISTOR 3.3K 5% .25W FC TC=-400/+700	01121	C83325
A2R4	0757-0288	1	6	RESISTOR 9.09K 1% .125W F TC=0+-100	19701	MF4C1/8-T0-9091-F
A2R5	0683-4705	8		RESISTOR 47 5% .25W FC TC=-400/+500	01121	C84705
A2R6	0683-2225	3		RESISTOR 2.2K 5% .25W FC TC=-400/+700	01121	C82225
A2R7	0683-4705	8		RESISTOR 47 5% .25W FC TC=-400/+500	01121	C84705
A2R8	2100-3161	6		RESISTOR-TMR 20K 10% C SIDE-ADJ 17-TRN	02111	43P203
A2R9	0683-4725	2		RESISTOR 4.7K 5% .25W FC TC=-400/+700	01121	C84725
A2R10	0683-3325	6		RESISTOR 3.3K 5% .25W FC TC=-400/+700	01121	C83325
A2R11	0757-0288	1		RESISTOR 9.09K 1% .125W F TC=0+-100	19701	MF4C1/8-T0-9091-F
A2R12	0683-4705	6		RESISTOR 47 5% .25W FC TC=-400/+500	01121	C84705
A2R13	0683-2225	3		RESISTOR 2.2K 5% .25W FC TC=-400/+700	01121	C82225
A2R14	0683-4705	8		RESISTOR 47 5% .25W FC TC=-400/+500	01121	C84705
A2R15	0683-1035	1		RESISTOR 10K 5% .25W FC TC=-400/+700	01121	C81035
A2R16	0683-1025	9		RESISTOR 1K 5% .25W FC TC=-400/+600	01121	C81025
A2R17	0683-4735	4	9	RESISTOR 47K 5% .25W FC TC=-400/+800	01121	C84735
A2R18	0683-4735	4		RESISTOR 47K 5% .25W FC TC=-400/+800	01121	C84735
A2R19	0757-0288	1		RESISTOR 9.09K 1% .125W F TC=0+-100	19701	MF4C1/8-T0-9091-F
A2R20	0683-4725	2		RESISTOR 4.7K 5% .25W FC TC=-400/+700	01121	C84725
A2R21	0683-4725	2		RESISTOR 4.7K 5% .25W FC TC=-400/+700	01121	C84725
A2R22	0683-1825	7	6	RESISTOR 1.8K 5% .25W FC TC=-400/+700	01121	C81825
A2R23	0683-4725	2		RESISTOR 4.7K 5% .25W FC TC=-400/+700	01121	C84725
A2R24	0683-4725	2		RESISTOR 4.7K 5% .25W FC TC=-400/+700	01121	C84725
A2R25	0683-3325	6		RESISTOR 3.3K 5% .25W FC TC=-400/+700	01121	C83325
A2R26	0698-8473	0		RESISTOR 3.358K 0.1% .1W F TC=0+-100	24546	
A2R27	0683-3315	4	2	RESISTOR 330 5% .25W FC TC=-400/+600	01121	C83315
A2R28	0698-8473	0		RESISTOR 3.358K 0.1% .1W F TC=0+-100	24546	
A2R29	0698-6943	3	9	RESISTOR 20K 0.1% .125W F TC=0+-100	24546	
A2R30	0698-6943	3		RESISTOR 20K 0.1% .125W F TC=0+-100	24546	
A2R31	0698-7842	8	8	RESISTOR 26.1K 0.1% .125W F TC=0+-100	24546	
A2R32	0698-7842	8		RESISTOR 26.1K 0.1% .125W F TC=0+-100	24546	
A2R33	0683-3325	6		RESISTOR 3.3K 5% .25W FC TC=-400/+700	01121	C83325
A2R34	0698-8473	0		RESISTOR 3.358K 0.1% .1W F TC=0+-100	24546	
A2R35	0683-3315	4		RESISTOR 330 5% .25W FC TC=-400/+600	01121	C83315

See introduction to this section for ordering information  
\*Indicates factory selected value

Table 6-3. Replaceable Parts (Cont'd).

Reference Designation	HP Part Number	C D	Qty	Description	Mfr Code	Mfr Part Number
A2R36	0698-8473	0		RESISTOR 3.358K 0.1% .125W F TC=0+-100	24546	
A2R37	0698-6943	3		RESISTOR 20K 0.1% .125W F TC=0+-100	24546	
A2R38	0698-6943	3		RESISTOR 20K 0.1% .125W F TC=0+-100	24546	
A2R39	0698-7842	R		RESISTOR 26.1K 0.1% .125W F TC=0+-100	24546	
A2R40	0698-7842	R		RESISTOR 26.1K 0.1% .125W F TC=0+-100	24546	
A2R41	0683-1015	7		RESISTOR 100 5% .25W FC TC=-400/+500	01121	CB1015
A2R42	0683-1015	7		RESISTOR 100 5% .25W FC TC=-400/+500	01121	CB1015
A2R43	2100-3351	6	2	RESISTOR-TRMR 500 10% C SIDE-ADJ 1-TRN	28480	2100-3351
A2R44	0757-0439	4	5	RESISTOR 6.8K 1% .125W F TC=0+-100	24546	C4-1/8-T0=6811-F
A2R45	0757-0279	0		RESISTOR 3.16K 1% .125W F TC=0+-100	24546	C4-1/8-T0=3161-F
A2R46	0683-3325	6		RESISTOR 3.3K 5% .25W FC TC=-400/+700	01121	CB3325
A2R47	0683-4705	R		RESISTOR 47 5% .25W FC TC=-400/+500	01121	CB4705
A2R48	0683-2225	3		RESISTOR 2.2K 5% .25W FC TC=-400/+700	01121	CB2225
A2R49	0683-1035	1		RESISTOR 10K 5% .25W FC TC=-400/+700	01121	CB1035
A2R50	0683-1035	1		RESISTOR 10K 5% .25W FC TC=-400/+700	01121	CB1035
A2R51	0683-1035	1		RESISTOR 10K 5% .25W FC TC=-400/+700	01121	CB1035
A2R52	0683-1035	1		RESISTOR 10K 5% .25W FC TC=-400/+700	01121	CB1035
A2R53	0683-1035	1		RESISTOR 10K 5% .25W FC TC=-400/+700	01121	CB1035
A2R54	0683-1055	5	3	RESISTOR 1M 5% .25W FC TC=-800/+900	01121	CB1055
A2R55	0683-1035	1		RESISTOR 10K 5% .25W FC TC=-400/+700	01121	CB1035
A2R56	0683-1035	1		RESISTOR 10K 5% .25W FC TC=-400/+700	01121	CB1035
A2R57	0683-1035	1		RESISTOR 10K 5% .25W FC TC=-400/+700	01121	CB1035
A2R58	0683-1035	1		RESISTOR 10K 5% .25W FC TC=-400/+700	01121	CB1035
A2R59	0683-1055	5		RESISTOR 1M 5% .25W FC TC=-800/+900	01121	CB1055
A2R60	1990-0404	8	1	LED-VISIBLE LUM-INT=300UCD IF=50MA-MAX	28480	5082-4480
A2R61	0683-3335	6		RESISTOR 33K 5% .25W FC TC=-400/+800	01121	CB3335
A2R62	0683-4725	2		RESISTOR 4.7K 5% .25W FC TC=-400/+700	01121	CB4725
A2R63	0683-4725	2		RESISTOR 4.7K 5% .25W FC TC=-400/+700	01121	CB4725
A2R64	0696-3453	2	2	RESISTOR 196K 1% .125W F TC=0+-100	24546	C4-1/8-T0=1963-F
A2R65	0757-0280	3		RESISTOR 1K 1% .125W F TC=0+-100	24546	C4-1/8-T0=1001-F
A2R66	0696-3453	2		RESISTOR 196K 1% .125W F TC=0+-100	24546	C4-1/8-T0=1963-F
A2R67	0683-2235	5		RESISTOR 22K 5% .25W FC TC=-400/+800	01121	CB2235
A2R67	0757-0280	3		RESISTOR 1K 1% .125W F TC=0+-100	24546	C4-1/8-T0=1001-F
A2R68	0683-2235	5		RESISTOR 22K 5% .25W FC TC=-400/+800	01121	CB2235
A2R69	0683-2235	5		RESISTOR 22K 5% .25W FC TC=-400/+800	01121	CB2235
A2R70	0683-2235	5		RESISTOR 22K 5% .25W FC TC=-400/+800	01121	CB2235
A2R71	0683-3335	6		RESISTOR 33K 5% .25W FC TC=-400/+800	01121	CB3335
A2R72	0683-2235	5		RESISTOR 22K 5% .25W FC TC=-400/+800	01121	CB2235
A2R73	0683-2225	5		RESISTOR 2.2K 5% .25W FC TC=-400/+700	01121	CB2225
A2R74	0757-0288	1		RESISTOR 9.09K 1% .125W F TC=0+-100	19701	MF4C1/8-T0=9091-F
A2R75	0683-4725	2		RESISTOR 4.7K 5% .25W FC TC=-400/+700	01121	CB4725
A2R76	0683-4725	2		RESISTOR 4.7K 5% .25W FC TC=-400/+700	01121	CB4725
A2R77	0683-2225	3		RESISTOR 2.2K 5% .25W FC TC=-400/+700	01121	CB2225
A2R78	0683-4725	2		RESISTOR 4.7K 5% .25W FC TC=-400/+700	01121	CB4725
A2R79	0683-4725	2		RESISTOR 4.7K 5% .25W FC TC=-400/+700	01121	CB4725
A2R80	0683-2225	3		RESISTOR 2.2K 5% .25W FC TC=-400/+700	01121	CB2225
A2R81	0757-0288	1		RESISTOR 9.09K 1% .125W F TC=0+-100	19701	MF4C1/8-T0=9091-F
A2R82	0683-4725	2		RESISTOR 4.7K 5% .25W FC TC=-400/+700	01121	CB4725
A2R83	0683-4725	2		RESISTOR 4.7K 5% .25W FC TC=-400/+700	01121	CB4725
A2R84	0683-2225	3		RESISTOR 2.2K 5% .25W FC TC=-400/+700	01121	CB2225
A2R85	0683-4725	2		RESISTOR 4.7K 5% .25W FC TC=-400/+700	01121	CB4725
A2R86	0683-4725	2		RESISTOR 4.7K 5% .25W FC TC=-400/+700	01121	CB4725
A2R87	0757-0442	9		RESISTOR 10K 1% .125W F TC=0+-100	24546	C4-1/8-T0=1002-F
A2R88	0757-0444	1	1	RESISTOR 12.1K 1% .125W F TC=0+-100	24546	C4-1/8-T0=1212-F
A2R89	0683-1835	9	15	RESISTOR 18K 5% .25W FC TC=-400/+800	01121	CB1835
A2R90	0683-1835	9		RESISTOR 18K 5% .25W FC TC=-400/+800	01121	CB1835
A2R91	0683-1835	9		RESISTOR 18K 5% .25W FC TC=-400/+800	01121	CB1835
A2R92	0683-4725	2		RESISTOR 4.7K 5% .25W FC TC=-400/+700	01121	CB4725
A2R93	0683-1035	1		RESISTOR 10K 5% .25W FC TC=-400/+700	01121	CB1035
A2R94	0683-4725	2		RESISTOR 4.7K 5% .25W FC TC=-400/+700	01121	CB4725
A2R95	0683-4725	2		RESISTOR 4.7K 5% .25W FC TC=-400/+700	01121	CB4725
A2R96	0683-1025	9		RESISTOR 1K 5% .25W FC TC=-400/+600	01121	CB1025
A2R97	0683-3325	6		RESISTOR 3.3K 5% .25W FC TC=-400/+700	01121	CB3325
A2R98	0683-4705	8		RESISTOR 47 5% .25W FC TC=-400/+500	01121	CB4705
A2R99	0683-4705	8		RESISTOR 47 5% .25W FC TC=-400/+500	01121	CB4705
A2R100	0683-3325	6		RESISTOR 3.3K 5% .25W FC TC=-400/+700	01121	CB3325
A2R101	0698-0084	9		RESISTOR 2.15K 1% .125W F TC=0+-100	24546	C4-1/8-T0=2151-F
A2R102	0683-1025	9		RESISTOR 1K 5% .25W FC TC=-400/+600	01121	CB1025
A2R103	0683-3325	6		RESISTOR 3.3K 5% .25W FC TC=-400/+700	01121	CB3325
A2R104	0683-4705	8		RESISTOR 47 5% .25W FC TC=-400/+500	01121	CB4705
A2R105	0683-4705	8		RESISTOR 47 5% .25W FC TC=-400/+500	01121	CB4705
A2R106	0683-3325	6		RESISTOR 3.3K 5% .25W FC TC=-400/+700	01121	CB3325
A2R107	0698-0084	9		RESISTOR 2.15K 1% .125W F TC=0+-100	24546	C4-1/8-T0=2151-F
A2R108	0683-4725	2		RESISTOR 4.7K 5% .25W FC TC=-400/+700	01121	CB4725
A2R109	0683-4725	2		RESISTOR 4.7K 5% .25W FC TC=-400/+700	01121	CB4725

See introduction to this section for ordering information  
\*Indicates factory selected value



Table 6-3. Replaceable Parts (Cont'd).

Reference Designation	HP Part Number	C D	Qty	Description	Mfr Code	Mfr Part Number
A2R110	0757-0442	9		RESISTOR 10K 1% .125W F TC=0+-100	24546	C4-1/8-T0-1002-F
A2R111	0757-0288	1		RESISTOR 9.09K 1% .125W F TC=0+-100	19701	MF4C1/8-T0-9091-F
A2R112	0683-1025	9		RESISTOR 1K 5% .25W FC TC=400/+600	01121	C81025
A2R113	0683-1025	9		RESISTOR 1K 5% .25W FC TC=400/+600	01121	C81025
A2R114	0683-1025	9		RESISTOR 1K 5% .25W FC TC=400/+600	01121	C81025
A2R115	0683-0335	2	2	RESISTOR 3.3 5% .25W FC TC=400/+500	01121	C83305
A2R116	0683-0335	2		RESISTOR 3.3 5% .25W FC TC=400/+500	01121	C83305
A2R117	0698-3160	8		RESISTOR 31.6K 1% .125W F TC=0+-100	24546	C4-1/8-T0-3162-F
A2R118	0698-3160	8		RESISTOR 31.6K 1% .125W F TC=0+-100	24546	C4-1/8-T0-3162-F
A2T1	9100-0875	0	1	TRANSFORMER-SIGNAL	28480	9100-0875
A2U1	1826-0139	9	2	OP AMP GP DUAL 8-DIP-P	01928	CA1458G
A2U2	1820-0427	6	3	MODULATOR T0-100	04713	MC1496G
A2U3	5080-3056	7	2	IC, LINER	28480	5080-3056
A2U4	5080-3056	7		IC, LINER	28480	5080-3056
A2U5	1826-00A1	0	0	OP AMP WB T0-99	27014	LM318H
A2U6	1826-0222	1	4	OP AMP GP QUAD 14-DIP-P	07263	UA4136PC
A2U7	1826-0222	1		OP AMP GP QUAD 14-DIP-P	07263	UA4136PC
A2U8	1826-0138	8		COMPARATOR GP QUAD 14-DIP-P	04713	MLM339P
A2U9	1826-0319	7		OP AMP BIFET T0-99	27014	LF356H
A2U10	1820-0427	6		MODULATOR T0-100	04713	MC1496G
A2U11	1820-0427	6		MODULATOR T0-100	04713	MC1496G
A2U12	1826-0139	9		OP AMP GP DUAL 8-DIP-P	01928	CA1458G
				A2 MISCELLANEOUS PARTS		
	04274-26502	5		PC BOARD, BLANK	28480	04274-26502
A3	04274-66503	0	1	POWER AMPLIFIER BOARD ASSEMBLY	28480	04274-66503
A3C1	0180-1078	6	5	CAPACITOR, FXD 330 UF 0.3VDCW AL	28480	0180-1078
A3C2	0180-1085	5		CAPACITOR, FXD 4.7 UF 16VDCW TA	28480	0180-1085
A3C3	0180-1085	5		CAPACITOR, FXD 4.7 UF 16VDCW TA	28480	0180-1085
A3C4	0180-1085	5		CAPACITOR, FXD 4.7 UF 16VDCW TA	28480	0180-1085
A3C5	0180-1085	5		CAPACITOR, FXD 4.7 UF 16VDCW TA	28480	0180-1085
A3C6	0160-0127	2		CAPACITOR-FXD 1UF +-20% 25VDC CER	28480	0160-0127
A3C7	0160-2141	6		CAPACITOR-FXD 3.3UF+-10% 50VDC TA	56289	150D335X9050B2
A3C8	0180-1077	5		CAPACITOR, FXD 220 UF 16 VDCW AL	28480	0180-1077
A3C9	0160-3443	1		CAPACITOR-FXD .1UF +80-20% 50VDC CER	28480	0160-3443
A3C10	0160-3443	1		CAPACITOR-FXD .1UF +80-20% 50VDC CER	28480	0160-3443
A3C11	0160-3443	1		CAPACITOR-FXD .1UF +80-20% 50VDC CER	28480	0160-3443
A3C12	0180-1085	5		CAPACITOR, FXD 4.7 UF 16VDCW TA	28480	0180-1085
A3C13	0180-1085	5		CAPACITOR, FXD 4.7 UF 16VDCW TA	28480	0180-1085
A3C14	0180-0228	6		CAPACITOR-FXD 22UF+-10% 15VDC TA	56289	150D226X9015B2
A3C15	0180-0228	6		CAPACITOR-FXD 22UF+-10% 15VDC TA	56289	150D226X9015B2
A3C16	0180-1078	6		CAPACITOR, FXD 330 UF 0.3VDCW AL	28480	0180-1078
A3C17	0180-1077	5		CAPACITOR, FXD 220 UF 16 VDCW AL	28480	0180-1077
A3C18	0180-1077	5		CAPACITOR, FXD 220 UF 16 VDCW AL	28480	0180-1077
A3C19	0150-0052	1	2	CAPACITOR-FXD .05UF +-20% 400VDC CER	28480	0150-0052
A3C20	0150-0052	1		CAPACITOR-FXD .05UF +-20% 400VDC CER	28480	0150-0052
A3C21	0180-1085	5		CAPACITOR, FXD 4.7 UF 16VDCW TA	28480	0180-1085
A3C22	0180-1078	6		CAPACITOR, FXD 330 UF 0.3VDCW AL	28480	0180-1078
A3C23	0180-1085	5		CAPACITOR, FXD 4.7 UF 16VDCW TA	28480	0180-1085
A3C24	0160-0127	2		CAPACITOR-FXD 1UF +-20% 25VDC CER	28480	0160-0127
A3C25	0180-1085	5		CAPACITOR, FXD 4.7 UF 16VDCW TA	28480	0180-1085
A3C26	0180-1085	5		CAPACITOR, FXD 4.7 UF 16VDCW TA	28480	0180-1085
A3C27	0180-2141	6		CAPACITOR-FXD 3.3UF+-10% 50VDC TA	56289	150D335X9050B2
A3C28	0160-3443	1		CAPACITOR-FXD .1UF +80-20% 50VDC CER	28480	0160-3443
A3C29	0160-3443	1		CAPACITOR-FXD .1UF +80-20% 50VDC CER	28480	0160-3443
A3C30	0160-3443	1		CAPACITOR-FXD .1UF +80-20% 50VDC CER	28480	0160-3443
A3C31	0160-3443	1		CAPACITOR-FXD .1UF +80-20% 50VDC CER	28480	0160-3443
A3C32	0160-3443	1		CAPACITOR-FXD .1UF +80-20% 50VDC CER	28480	0160-3443
A3C33	0180-1085	5		CAPACITOR, FXD 4.7 UF 16VDCW TA	28480	0180-1085
A3C34	0180-1085	5		CAPACITOR, FXD 4.7 UF 16VDCW TA	28480	0180-1085
A3C35	0180-0228	6		CAPACITOR-FXD 22UF+-10% 15VDC TA	56289	150D226X9015B2
A3C36	0180-0228	6		CAPACITOR-FXD 22UF+-10% 15VDC TA	56289	150D226X9015B2
A3C37	0180-1077	5		CAPACITOR, FXD 220 UF 16 VDCW AL	28480	0180-1077
A3C38	0180-1049	1		CAPACITOR, FXD 470 UF 16VDCW	28480	0180-1049
A3C39	0180-1049	1		CAPACITOR, FXD 470 UF 16VDCW	28480	0180-1049
A3C40	0180-1077	5		CAPACITOR, FXD 220 UF 16 VDCW AL	28480	0180-1077
A3C41	0180-1077	5		CAPACITOR, FXD 220 UF 16 VDCW AL	28480	0180-1077
A3C42	0180-1085	5		CAPACITOR, FXD 4.7 UF 16VDCW TA	28480	0180-1085
A3C43	0180-1085	5		CAPACITOR, FXD 4.7 UF 16VDCW TA	28480	0180-1085
A3C44	0180-1085	5		CAPACITOR, FXD 4.7 UF 16VDCW TA	28480	0180-1085
A3C45	0160-1085	5		CAPACITOR, FXD 4.7 UF 16VDCW TA	28480	0180-1085

See introduction to this section for ordering information  
\*Indicates factory selected value

Table 6-3. Replaceable Parts (Cont'd).

Reference Designation	HP Part Number	C D	Qty	Description	Mfr Code	Mfr Part Number
A3C46	0180-1049	1		CAPACITOR, FXD 470 UF 16VDCW	28480	0180-1049
A3C47	0180-1049	1		CAPACITOR, FXD 470 UF 16VDCW	28480	0180-1049
A3C48	0180-1049	1		CAPACITOR, FXD 470 UF 16VDCW	28480	0180-1049
A3C49	0180-1049	1		CAPACITOR, FXD 470 UF 16VDCW	28480	0180-1049
A3C50	0180-1085	5		CAPACITOR, FXD 4.7 UF 16VDCW TA	28480	0180-1085
A3C51	0180-1085	5		CAPACITOR, FXD 4.7 UF 16VDCW TA	28480	0180-1085
A3C52	0180-1078	6		CAPACITOR, FXD 330 UF 6.3VDCW AL	28480	0180-1078
A3C53	0180-1085	5		CAPACITOR, FXD 4.7 UF 16VDCW TA	28480	0180-1085
A3C60	0180-1078	6		CAPACITOR, FXD 330 UF 6.3VDCW AL	28480	0180-1078
A3CR1	1902-3160	4		DIODE-ZNR 10V 2x DO-7 PDA.4W TC=+.06%	28480	1902-3160
A3CR2	1901-0040	1		DIODE-SWITCHING 30V 50MA 2NS DO-35	28480	1901-0040
A3CR3	1901-0040	1		DIODE-SWITCHING 30V 50MA 2NS DO-35	28480	1901-0040
A3CR4	1901-0040	1		DIODE-SWITCHING 30V 50MA 2NS DO-35	28480	1901-0040
A3CR5	1901-0040	1		DIODE-SWITCHING 30V 50MA 2NS DO-35	28480	1901-0040
A3CR6	1901-0040	1		DIODE-SWITCHING 30V 50MA 2NS DO-35	28480	1901-0040
A3CR7	1901-0040	1		DIODE-SWITCHING 30V 50MA 2NS DO-35	28480	1901-0040
A3CR8	1901-0033	2		DIODE-GEN PRP 180V 200MA DO-7	28480	1901-0033
A3CR9	1901-0033	2		DIODE-GEN PRP 180V 200MA DO-7	28480	1901-0033
A3CR10	1901-0040	1		DIODE-SWITCHING 30V 50MA 2NS DO-35	28480	1901-0040
A3CR11	1901-0040	1		DIODE-SWITCHING 30V 50MA 2NS DO-35	28480	1901-0040
A3CR12	1901-0040	1		DIODE-SWITCHING 30V 50MA 2NS DO-35	28480	1901-0040
A3CR13	1901-0040	1		DIODE-SWITCHING 30V 50MA 2NS DO-35	28480	1901-0040
A3CR14	1901-0040	1		DIODE-SWITCHING 30V 50MA 2NS DO-35	28480	1901-0040
A3CR15	1901-0040	1		DIODE-SWITCHING 30V 50MA 2NS DO-35	28480	1901-0040
A3CR16	1901-0025	2		DIODE-GEN PRP 100V 200MA DO-7	28480	1901-0025
A3CR17	1902-0048	1	1	DIODE-ZNR 6.81V 5% DO-7 PDA.4W TC=+.043%	28480	1902-0048
A3CR18	1902-3160	4		DIODE-ZNR 10V 2x DO-7 PDA.4W TC=+.06%	28480	1902-3160
A3L1	9140-0129	1	10	COIL-MLD 220UH 5% Q65 .155DX.375LG-NOM	28480	9140-0129
A3L2	9140-0129	1		COIL-MLD 220UH 5% Q65 .155DX.375LG-NOM	28480	9140-0129
A3L3	9140-0129	1		COIL-MLD 220UH 5% Q65 .155DX.375LG-NOM	28480	9140-0129
A3Q1	1855-0261	9		TRANSISTOR MOS-FET	28480	1855-0261
A3Q2	1854-0129	0		TRANSISTOR NPN SI	28480	1854-0129
A3Q3	1854-0129	0		TRANSISTOR NPN SI	28480	1854-0129
A3Q4	1854-0129	0		TRANSISTOR NPN SI	28480	1854-0129
A3Q5	1854-0071	7		TRANSISTOR NPN SI PD=300MW FT=200MHZ	28480	1854-0071
A3Q6	1854-0039	7		TRANSISTOR NPN 2N3053B SI TO-39 PD=1W	01928	2N3053B
A3Q7	1853-0020	4		TRANSISTOR PNP SI PD=300MW FT=150MHZ	28480	1853-0020
A3Q8	1853-0012	4		TRANSISTOR PNP 2N2904A SI TO-39 PD=600MW	01295	2N2904A
A3Q9	1855-0261	0		TRANSISTOR MOS-FET	28480	1855-0261
A3Q10	1854-0129	6		TRANSISTOR NPN SI	28480	1854-0129
A3Q11	1854-0129	6		TRANSISTOR NPN SI	28480	1854-0129
A3Q12	1854-0129	6		TRANSISTOR NPN SI	28480	1854-0129
A3Q13	1854-0129	6		TRANSISTOR NPN SI	28480	1854-0129
A3Q14	1854-0129	6		TRANSISTOR NPN SI	28480	1854-0129
A3Q15	1854-0071	7		TRANSISTOR NPN SI PD=300MW FT=200MHZ	28480	1854-0071
A3Q16	1853-0020	4		TRANSISTOR PNP SI PD=300MW FT=150MHZ	28480	1853-0020
A3Q17	1854-0039	7		TRANSISTOR NPN 2N3053B SI TO-39 PD=1W	01928	2N3053B
A3Q18	1853-0012	4		TRANSISTOR PNP 2N2904A SI TO-39 PD=600MW	01295	2N2904A
A3R1	2100-0552	3	2	RESISTOR-TRMR 50 10% C SIDE-ADJ 1-TRN	28480	2100-0552
A3R2	0698-3445	2	2	RESISTOR 348 1% .125W F TC=0+100	24546	C4-1/8-T0-348R-F
A3R3	0698-3438	4	1	RESISTOR 1470 +-1% .125W FILM	24546	
A3R4	0757-0442	9		RESISTOR 10K 1% .125W F TC=0+100	24546	C4-1/8-T0-1002-F
A3R5	0757-0458	7	4	RESISTOR 51.1K 1% .125W F TC=0+100	24546	C4-1/8-T0-5112-F
A3R6	0683-1045	3	16	RESISTOR 100K 5% .25W FC TC=400/+800	01121	CB1045
A3R7	0683-1045	3		RESISTOR 100K 5% .25W FC TC=400/+800	01121	CB1045
A3R8	0683-1005	5		RESISTOR 10 5% .25W FC TC=400/+500	01121	CB1005
A3R9	0698-2233	4	2	RESISTOR 1.6k +-5% .125W	28480	0698-2233
A3R10	0698-2233	4		RESISTOR 1.6k +-5% .125W	28480	0698-2233
A3R11	0683-3335	6		RESISTOR 33k 5% .25W FC TC=400/+800	01121	CB3335
A3R12	0683-2225	3		RESISTOR 2.2k 5% .25W FC TC=400/+700	01121	CB2225
A3R13	0683-1005	5		RESISTOR 10 5% .25W FC TC=400/+500	01121	CB1005
A3R14	0698-4207	0	1	RESISTOR 44.2k 1% .125W F TC=0+100	24546	C4-1/8-T0-4422-F
A3R15	0698-3440	7		RESISTOR 196 1% .125W F TC=0+100	24546	C4-1/8-T0-196R-F
A3R16	2100-3207	1	2	RESISTOR-TRMR 5K 10% C SIDE-ADJ 1-TRN	28480	2100-3207
A3R17	0698-0084	9		RESISTOR 2.15K 1% .125W F TC=0+100	24546	C4-1/8-T0-2151-F
A3R18	0757-0442	9		RESISTOR 10K 1% .125W F TC=0+100	24546	C4-1/8-T0-1002-F
A3R19	0698-4469	2	2	RESISTOR 1.15K 1% .125W F TC=0+100	24546	C4-1/8-T0-1151-F
A3R20	0698-4404	5	1	RESISTOR 105 1% .125W F TC=0+100	24546	C4-1/8-T0-105R-F
A3R21	0698-4458	9	1	RESISTOR 590 1% .125W F TC=0+100	24546	C4-1/8-T0-590R-F
A3R22	0698-3155	1		RESISTOR 4.64k 1% .125W F TC=0+100	24546	C4-1/8-T0-4641-F
A3R23	0698-3447	4	2	RESISTOR 422 1% .125W F TC=0+100	24546	C4-1/8-T0-422R-F
A3R24	0683-1035	1		RESISTOR 10K 5% .25W FC TC=400/+700	01121	CB1035
A3R25	0683-1035	1		RESISTOR 10K 5% .25W FC TC=400/+700	01121	CB1035

See introduction to this section for ordering information  
\*Indicates factory selected value

Table 6-3. Replaceable Parts (Cont'd).

Reference Designation	HP Part Number	C D	Qty	Description	Mfr Code	Mfr Part Number
A3R26	0683-1035	1		RESISTOR 10K 5% .25W FC TC=-400/+700	01121	CB1035
A3R27	0683-1005	5		RESISTOR 10 5% .25W FC TC=-400/+500	01121	CB1005
A3R28	0683-1005	5		RESISTOR 10 5% .25W FC TC=-400/+500	01121	CB1005
A3R29	0757-0276	7	4	RESISTOR 61.9 1% .125W F TC=0+-100	24546	C4-1/8-T0-6192-F
A3R30	0698-3155	1		RESISTOR 4.64K 1% .125W F TC=0+-100	24546	C4-1/8-T0-4641-F
A3R31	0757-0276	7		RESISTOR 61.9 1% .125W F TC=0+-100	24546	C4-1/8-T0-6192-F
A3R32	0698-3154	0		RESISTOR 4.22K 1% .125W F TC=0+-100	24546	C4-1/8-T0-4221-F
A3R33	0757-0316	6	2	RESISTOR 42.2 1% .125W F TC=0+-100	24546	C4-1/8-T0-4221-F
A3R34	0683-4705	8		RESISTOR 47 5% .25W FC TC=-400/+500	01121	CB4705
A3R35	0683-0475	1	6	RESISTOR 4.7 5% .25W FC TC=-400/+500	01121	CB4705
A3R36	0683-0475	0		RESISTOR 4.7 5% .25W FC TC=-400/+500	01121	CB4705
A3R37	0698-3154	0		RESISTOR 4.22K 1% .125W F TC=0+-100	24546	C4-1/8-T0-4221-F
A3R38	0683-4705	8		RESISTOR 47 5% .25W FC TC=-400/+500	01121	CB4705
A3R39	0698-3397	7	3	RESISTOR 42.2 1% .5W F TC=0+-100	28480	
A3R40	0698-3397	7		RESISTOR 42.2 1% .5W F TC=0+-100	28480	
A3R41	0698-3397	7		RESISTOR 42.2 1% .5W F TC=0+-100	28480	
A3R42	0683-1535	3		RESISTOR 15K 5% .25W FC TC=-400/+800	01121	CB1535
A3R43	0683-1535	3		RESISTOR 15K 5% .25W FC TC=-400/+800	01121	CB1535
A3R44	0757-0458	7		RESISTOR 51.1K 1% .125W F TC=0+-100	24546	C4-1/8-T0-5112-F
A3R45	0683-1045	3		RESISTOR 100K 5% .25W FC TC=-400/+800	01121	CB1045
A3R46	0683-1045	3		RESISTOR 100K 5% .25W FC TC=-400/+800	01121	CB1045
A3R47	0757-0442	9		RESISTOR 10K 1% .125W F TC=0+-100	24546	C4-1/8-T0-1002-F
A3R48	0757-0274	1	1	RESISTOR 1.21K 1% .125W F TC=0+-100	24546	
A3R49	0683-1005	5		RESISTOR 10 5% .25W FC TC=-400/+500	01121	CB1005
A3R50	0698-3495	8	1	RESISTOR 866 1% .125W F TC=0+-100	24546	
A3R51	0683-3335	8		RESISTOR 33K 5% .25W FC TC=-400/+800	01121	CB3335
A3R52	0683-2225	3		RESISTOR 2.2K 5% .25W FC TC=-400/+700	01121	CB2225
A3R53	0683-1005	5		RESISTOR 10 5% .25W FC TC=-400/+500	01121	CB1005
A3R54	0757-0274	5		RESISTOR 1.21K 1% .125W F TC=0+-100	24546	C4-1/8-T0-1213-F
A3R55	0757-0403	2	2	RESISTOR 121 1% .125W F TC=0+-100	24546	C4-1/8-T0-121R-F
A3R56	0757-0279	0		RESISTOR 3.16K 1% .125W F TC=0+-100	24546	C4-1/8-T0-3161-F
A3R57	0757-0442	9		RESISTOR 10K 1% .125W F TC=0+-100	24546	C4-1/8-T0-1002-F
A3R58	0683-1035	1		RESISTOR 10K 5% .25W FC TC=-400/+700	01121	CB1035
A3R59	0698-4308	8	1	RESISTOR 16.9K 1% .125W F TC=0+-100	24546	C4-1/8-T0-1692-F
A3R60	0698-4125	7	1	RESISTOR 933 1% .125W F TC=0+-100	24546	C4-1/8-T0-933R-F
A3R61	0757-0399	5	1	RESISTOR 82.5 1% .125W F TC=0+-100	24546	C4-1/8-T0-825F-F
A3R62	0757-0441	8	1	RESISTOR 8.25K 1% .125W F TC=0+-100	24546	C4-1/8-T0-8251-F
A3R63	0698-3136	0	3	RESISTOR 17.8K 1% .125W F TC=0+-100	24546	C4-1/8-T0-1782-F
A3R64	0698-3155	1		RESISTOR 4.64K 1% .125W F TC=0+-100	24546	C4-1/8-T0-4641-F
A3R65	0698-4469	2		RESISTOR 1.15K 1% .125W F TC=0+-100	24546	C4-1/8-T0-1151-F
A3R66	0683-1035	1		RESISTOR 10K 5% .25W FC TC=-400/+700	01121	CB1035
A3R67	0683-1035	1		RESISTOR 10K 5% .25W FC TC=-400/+700	01121	CB1035
A3R68	0683-1035	1		RESISTOR 10K 5% .25W FC TC=-400/+700	01121	CB1035
A3R69	0683-1035	1		RESISTOR 10K 5% .25W FC TC=-400/+700	01121	CB1035
A3R70	0683-1005	5		RESISTOR 10 5% .25W FC TC=-400/+500	01121	CB1005
A3R71	0683-1005	5		RESISTOR 10 5% .25W FC TC=-400/+500	01121	CB1005
A3R72	0757-0276	7		RESISTOR 61.9 1% .125W F TC=0+-100	24546	C4-1/8-T0-6192-F
A3R73	0698-3155	1		RESISTOR 4.64K 1% .125W F TC=0+-100	24546	C4-1/8-T0-4641-F
A3R74	0698-3154	0		RESISTOR 4.22K 1% .125W F TC=0+-100	24546	C4-1/8-T0-4221-F
A3R75	0757-0276	7		RESISTOR 61.9 1% .125W F TC=0+-100	24546	C4-1/8-T0-6192-F
A3R76	0698-3154	0		RESISTOR 4.22K 1% .125W F TC=0+-100	24546	C4-1/8-T0-4221-F
A3R77	0757-0316	6		RESISTOR 42.2 1% .125W F TC=0+-100	24546	C4-1/8-T0-4221-F
A3R78	0683-4705	8		RESISTOR 47 5% .25W FC TC=-400/+500	01121	CB4705
A3R79	0683-0475	1		RESISTOR 4.7 5% .25W FC TC=-400/+500	01121	CB4705
A3R80	0683-0475	1		RESISTOR 4.7 5% .25W FC TC=-400/+500	01121	CB4705
A3R81	0683-4705	8		RESISTOR 47 5% .25W FC TC=-400/+500	01121	CB4705
A3R82	0698-2344	8	1	RESISTOR 2.45K +- .25% .125W	28480	0698-2344
A3R83	0698-2343	7	2	RESISTOR 50K +- .1% .125W	28480	0698-2343
A3R84	0683-1515	2		RESISTOR 150 5% .25W FC TC=-400/+600	01121	CB1515
A3R85	0757-0401	0		RESISTOR 100 1% .125W F TC=0+-100	24546	C4-1/8-T0-101-F
A3R86	0757-0280	3		RESISTOR 1K 1% .125W F TC=0+-100	24546	C4-1/8-T0-1001-F
A3R87	0683-2235	5		RESISTOR 22K 5% .25W FC TC=-400/+800	01121	CB2235
A3R88	0683-2235	5		RESISTOR 22K 5% .25W FC TC=-400/+800	01121	CB2235
A3R89	1810-0205	7		NETWORK-RES 8-PIN-SIP .1-PIN-SPCG	01121	208A472
A3R90	1810-0205	7		NETWORK-RES 8-PIN-SIP .1-PIN-SPCG	01121	208A472
A3R91	1810-0212	6	1	NETWORK-RES 16-PIN-DIP .1-PIN-SPCG	01121	3168223
A3R92	0683-5625	3	10	RESISTOR 5.6K 5% .25W FC TC=-400/+700	01121	CB5625
A3R100	0683-7505	2	1	RESISTOR 75 5% .25W FC TC=-400/+500	01121	CB7505
A3T1	9100-0855	6	5	TRANSFORMER, PULSE	28480	9100-0855
A3T2	9100-0872	7	2	TRANSFORMER, SIGNAL	28480	9100-0872
A3T3	9100-0873	8	1	TRANSFORMER, SIGNAL	28480	9100-0873
A3T4	9100-0855	5		TRANSFORMER, PULSE	28480	9100-0855
A3T5	9100-0872	7		TRANSFORMER, SIGNAL	28480	9100-0872
A3U1	1826-0081	0		OP AMP WB T0-99	27014	LM318M
A3U2	1826-0081	0		OP AMP WB T0-99	27014	LM318M
A3U3	1826-0081	0		OP AMP WB T0-99	27014	LM318M
A3U4	1826-0081	0		OP AMP WB T0-99	27014	LM318M
A3U5	1826-0138	8		COMPARATOR GP QUAD 14-DIP-P	04713	MLM339P

See introduction to this section for ordering information  
\*Indicates factory selected value

Table 6-3. Replaceable Parts (Cont'd).

Reference Designation	HP Part Number	C D	Qty	Description	Mfr Code	Mfr Part Number
A3U6	1826-0138	8	13	COMPARATOR GP QUAD 14-DIP-P	04713	MLM339P
A3U7	1826-0138	8		COMPARATOR GP QUAD 14-DIP-P	04713	MLM339P
A3U8	1820-1730	6		IC FF TTL LS D-TYPE POS-EDGE-TRIG COM	01295	8N74LS273N
A3U9	1820-1730	6		IC FF TTL LS D-TYPE POS-EDGE-TRIG COM	01295	8N74LS273N
A3U10	1820-1730	6		IC FF TTL LS D-TYPE POS-EDGE-TRIG COM	01295	8N74LS273N
				A3 MISCELLANEOUS PARTS		
	04274-26503	6		PC BOARD, BLANK	28480	04274-26503
A4	04274-66504	1	1	PROCESS AMPLIFIER BOARD ASSEMBLY	28480	04274-66504
A4C1	0160-1241	3	2	CAPACITOR, FXD 0.047 UF 10%	28480	0160-1241
A4C2	0160-1563	2		CAPACITOR-FXD .47UF +-5% 200VDC	28480	0160-1563
A4C3	0121-0105	4		CAPACITOR-V TRMR-CER 9-35PF 200V PC-MTG	52763	304324 9/35PF N650
A4C4	0121-0059	7		CAPACITOR-V TRMR-CER 2-8PF 350V PC-MTG	52763	304324 2/8PF NPO
A4C5	0121-0105	4		CAPACITOR-V TRMR-CER 9-35PF 200V PC-MTG	52763	304324 9/35PF N650
A4C6	0121-0105	9	1	CAPACITOR-V TRMR-CER 9-35PF 350V	52763	
A4C7	0121-0059	7		CAPACITOR-V TRMR-CER 2-8PF 350V PC-MTG	52763	304324 2/8PF NPO
A4C9	0160-2055	9		CAPACITOR-FXD .01UF +80-20% 100VDC CER	28480	0160-2055
A4C10	0160-2055	9		CAPACITOR-FXD .01UF +80-20% 100VDC CER	28480	0160-2055
A4C11	0160-2265	3	3	CAPACITOR-FXD 22PF +-5% 500VDC CER 0+-30	28480	0160-2265
A4C12	0160-2940	1		CAPACITOR-FXD 070PF +-5% 300VDC MICA	28480	0160-2940
A4C13	0150-0121	5		CAPACITOR-FXD .1UF +80-20% 50VDC CER	28480	0150-0121
A4C14	0150-0121	5		CAPACITOR-FXD .1UF +80-20% 50VDC CER	28480	0150-0121
A4C15	0160-2265	3		CAPACITOR-FXD 22PF +-5% 500VDC CER 0+-30	28480	0160-2265
A4C16	0160-2250	6	1	CAPACITOR-FXD 5.1PF +-0.25PF 500VDC CER	28480	0160-2250
A4C17	0150-0121	5		CAPACITOR-FXD .1UF +80-20% 50VDC CER	28480	0150-0121
A4C18	0150-0121	5		CAPACITOR-FXD .1UF +80-20% 50VDC CER	28480	0150-0121
A4C19	0160-2208	4		CAPACITOR-FXD 330PF +-5% 300VDC MICA	28480	0160-2208
A4C20	0180-1085	5		CAPACITOR, FXD 4.7 UF 16VDCW TA	28480	0180-1085
A4C21	0180-1085	5		CAPACITOR, FXD 4.7 UF 16VDCW TA	28480	0180-1085
A4C22	0160-2265	3		CAPACITOR-FXD 22PF +-5% 500VDC CER 0+-30	28480	0160-2265
A4C23	0160-1241	3		CAPACITOR, FXD 0.047 UF 10%	28480	0160-1241
A4C24	0160-1563	2		CAPACITOR-FXD .47UF +-5% 200VDC	28480	0160-1563
A4C26	0150-0121	5		CAPACITOR-FXD .1UF +80-20% 50VDC CER	28480	0150-0121
A4C27	0150-0121	5		CAPACITOR-FXD .1UF +80-20% 50VDC CER	28480	0150-0121
A4C28	0160-1554	1	1	CIFXD MY 0.33 UF 5% 200VDCW	28480	0160-1554
A4C29	0180-1085	5		CAPACITOR, FXD 4.7 UF 16VDCW TA	28480	0180-1085
A4C30	0180-1085	5		CAPACITOR, FXD 4.7 UF 16VDCW TA	28480	0180-1085
A4C31	0160-2208	4		CAPACITOR-FXD 330PF +-5% 300VDC MICA	28480	0160-2208
A4C32	0180-1085	5		CAPACITOR, FXD 4.7 UF 16VDCW TA	28480	0180-1085
A4C33	0180-1085	5		CAPACITOR, FXD 4.7 UF 16VDCW TA	28480	0180-1085
A4C34	0180-1085	5		CAPACITOR, FXD 4.7 UF 16VDCW TA	28480	0180-1085
A4C35	0180-1061	7		CAPACITOR-FXD 220UF +50-10% 16VDC	28480	0180-1061
A4C36	0150-0121	5		CAPACITOR-FXD .1UF +80-20% 50VDC CER	28480	0150-0121
A4C37	0180-1061	7		CAPACITOR-FXD 220UF +50-10% 16VDC	28480	0180-1061
A4C38	0150-0121	5		CAPACITOR-FXD .1UF +80-20% 50VDC CER	28480	0150-0121
A4C39	0180-1061	7		CAPACITOR-FXD 220UF +50-10% 16VDC	28480	0180-1061
A4C40	0150-0121	5		CAPACITOR-FXD .1UF +80-20% 50VDC CER	28480	0150-0121
A4C41	0150-0071	4	1	CAPACITOR-FXD 400PF +-5% 1KVDC CER	28480	0150-0071
A4C42	0160-3456	1		CAPACITOR-FXD 1000PF +-10% CER 1000MVDC		
A4CR1	1901-0033	2		DIODE-GEN PRP 180V 200MA DO-7	28480	1901-0033
A4CR2	1901-0033	2		DIODE-GEN PRP 180V 200MA DO-7	28480	1901-0033
A4CR3	1901-0033	2		DIODE-GEN PRP 180V 200MA DO-7	28480	1901-0033
A4CR4	1901-0033	2		DIODE-GEN PRP 180V 200MA DO-7	28480	1901-0033
A4CR5	1901-0040	1		DIODE-SWITCHING 30V 50MA 2NS DO-35	28480	1901-0040
A4CR6	1901-0040	1		DIODE-SWITCHING 30V 50MA 2NS DO-35	28480	1901-0040
A4CR7	1901-0040	1		DIODE-SWITCHING 30V 50MA 2NS DO-35	28480	1901-0040
A4CR8	1901-0040	1		DIODE-SWITCHING 30V 50MA 2NS DO-35	28480	1901-0040
A4CR9	1901-0040	1		DIODE-SWITCHING 30V 50MA 2NS DO-35	28480	1901-0040
A4CR10	1901-0040	1		DIODE-SWITCHING 30V 50MA 2NS DO-35	28480	1901-0040
A4CR11	1901-0040	1		DIODE-SWITCHING 30V 50MA 2NS DO-35	28480	1901-0040
A4CR12	1901-0040	1		DIODE-SWITCHING 30V 50MA 2NS DO-35	28480	1901-0040
A4CR13	1901-0040	1		DIODE-SWITCHING 30V 50MA 2NS DO-35	28480	1901-0040
A4CR14	1901-0033	2		DIODE-GEN PRP 180V 200MA DO-7	28480	1901-0033
A4CR15	1901-0033	2		DIODE-GEN PRP 180V 200MA DO-7	28480	1901-0033
A4CR16	1901-0033	2		DIODE-GEN PRP 180V 200MA DO-7	28480	1901-0033
A4CR17	1901-0033	2		DIODE-GEN PRP 180V 200MA DO-7	28480	1901-0033
A4CR18	1901-0040	1		DIODE-SWITCHING 30V 50MA 2NS DO-35	28480	1901-0040
A4CR19	1901-0040	1		DIODE-SWITCHING 30V 50MA 2NS DO-35	28480	1901-0040
A4L1	9140-0098	3	1	COIL-MLD 2.2UH 10% Q=33 .155DX.375LG-NOM	28480	9140-0098
A4L2	9140-0129	1		COIL-MLD 220UH 5% Q=65 .155DX.375LG-NOM	28480	9140-0129
A4L3	9140-0129	1		COIL-MLD 220UH 5% Q=65 .155DX.375LG-NOM	28480	9140-0129
A4L4	9140-0129	1		COIL-MLD 220UH 5% Q=65 .155DX.375LG-NOM	28480	9140-0129
A4L5	9140-0129	1		COIL-MLD 220UH 5% Q=65 .155DX.375LG-NOM	28480	9140-0129

See introduction to this section for ordering information  
\*Indicates factory selected value

Table 6-3. Replaceable Parts (Cont'd).

Reference Designation	HP Part Number	C D	Qty	Description	Mfr Code	Mfr Part Number
A4L6	9140-0129	1		COIL-MLD 220UH 5% Q=65 .1550X.375LG-NOM	28480	9140-0129
A4Q1	1855-0119	b	15	TRANSISTOR J-FET N-CHAN Si	28480	1855-0119
A4Q2	1855-0119	b		TRANSISTOR J-FET N-CHAN Si	28480	1855-0119
A4Q3	1854-0129	b		TRANSISTOR NPN Si	28480	1854-0129
A4Q4	1855-0119	b		TRANSISTOR J-FET N-CHAN Si	28480	1855-0119
A4Q5	1855-0119	b		TRANSISTOR J-FET N-CHAN Si	28480	1855-0119
A4Q6	1855-0119	b		TRANSISTOR J-FET N-CHAN Si	28480	1855-0119
A4Q7	1855-0119	b		TRANSISTOR J-FET N-CHAN Si	28480	1855-0119
A4Q8	1855-0119	b		TRANSISTOR J-FET N-CHAN Si	28480	1855-0119
A4Q9	1855-0119	b		TRANSISTOR J-FET N-CHAN Si	28480	1855-0119
A4Q10	1855-0119	b		TRANSISTOR J-FET N-CHAN Si	28480	1855-0119
A4Q11	1855-0119	b		TRANSISTOR J-FET N-CHAN Si	28480	1855-0119
A4Q12	1854-0129	b		TRANSISTOR NPN Si	28480	1854-0129
A4Q13	1855-0119	b		TRANSISTOR J-FET N-CHAN Si	28480	1855-0119
A4Q14	1855-0119	b		TRANSISTOR J-FET N-CHAN Si	28480	1855-0119
A4Q15	1855-0119	b		TRANSISTOR J-FET N-CHAN Si	28480	1855-0119
A4Q16	1855-0119	b		TRANSISTOR J-FET N-CHAN Si	28480	1855-0119
A4Q17	1855-0119	b		TRANSISTOR J-FET N-CHAN Si	28480	1855-0119
A4Q18	1854-0129	b		TRANSISTOR NPN Si	28480	1854-0129
A4Q19	1854-0129	b		TRANSISTOR NPN Si	28480	1854-0129
A4Q20	1854-0129	b		TRANSISTOR NPN Si	28480	1854-0129
A4Q21	1854-0129	b		TRANSISTOR NPN Si	28480	1854-0129
A4Q22	1854-0129	b		TRANSISTOR NPN Si	28480	1854-0129
A4Q23	1854-0129	b		TRANSISTOR NPN Si	28480	1854-0129
A4R1	2100-3426	6		RESISTOR-TRMR 20 10% C SIDE-ADJ 1-TRN	28480	2100-3426
A4R2	2100-3356	1	2	RESISTOR-TRMR 200K 10% C SIDE-ADJ 1-TRN	28480	2100-3356
A4R3	0757-0488	3	3	RESISTOR 909K 1% .125W F TC=0+-100	28480	0757-0488
A4R4	0698-3159	5	2	RESISTOR 26.1K 1% .125W F TC=0+-100	24546	C4-1/8-T0=2612-F
A4R5	2100-3353	8	3	RESISTOR-TRMR 20K 10% C SIDE-ADJ 1-TRN	32997	3386X-Y46=203
A4R6	2100-3349	2	1	RESISTOR-TRMR 100 10% C SIDE-ADJ 1-TRN	28480	2100-3349
A4R7	2100-3426	6		RESISTOR-TRMR 20 10% C SIDE-ADJ 1-TRN	28480	2100-3426
A4R8	2100-3356	1		RESISTOR-TRMR 200K 10% C SIDE-ADJ 1-TRN	28480	2100-3356
A4R9	0683-2245	7	14	RESISTOR 220K 5% .25W FC TC=-800/+900	01121	C82245
A4R10	2100-3426	6		RESISTOR-TRMR 20 10% C SIDE-ADJ 1-TRN	28480	2100-3426
A4R11	2100-3426	6		RESISTOR-TRMR 20 10% C SIDE-ADJ 1-TRN	28480	2100-3426
A4R12	0698-3155	1		RESISTOR 4.64K 1% .125W F TC=0+-100	24546	C4-1/8-T0=4641-F
A4R13	0698-3155	1		RESISTOR 4.64K 1% .125W F TC=0+-100	24546	C4-1/8-T0=4641-F
A4R14	0698-3155	1		RESISTOR 4.64K 1% .125W F TC=0+-100	24546	C4-1/8-T0=4641-F
A4R15	0698-3155	1		RESISTOR 4.64K 1% .125W F TC=0+-100	24546	C4-1/8-T0=4641-F
A4R16	0683-5145	2	1	RESISTOR 510K 5% .25W FC TC=-800/+900	01121	C85145
A4R17	0698-2341	5		RESISTOR 4.5K +-1% .125W F TC=0+-100	28480	0698-2341
A4R18	0698-1430	5	1	RESISTOR 21.5 1% .125W F TC=0+-100	03888	PHE55-1/8-T0=21R5-F
A4R19	0698-2342	6	3	RESISTOR 450 +-1% .125W	28480	0698-2342
A4R20	0698-2283	4	1	RESISTOR, FXD 1.0 OHM 5% .25W	28480	0698-2283
A4R21	0698-2343	7		RESISTOR 50K +-1% .125W	28480	0698-2343
A4R22	0698-3440	7		RESISTOR 196 1% .125W F TC=0+-100	24546	C4-1/8-T0=196R-F
A4R23	0757-0278	9	2	RESISTOR 1.78K 1% .125W F TC=0+-100	24546	C4-1/8-T0=1781-F
A4R24	0698-3136	8		RESISTOR 17.8K 1% .125W F TC=0+-100	24546	C4-1/8-T0=1782-F
A4R25	0757-1094	9	2	RESISTOR 1.47K 1% .125W F TC=0+-100	24546	C4-1/8-T0=1471-F
A4R26	0698-4422	7	1	RESISTOR 1.27K 1% .125W F TC=0+-100	24546	C4-1/8-T0=1271-F
A4R27	0698-2207	2	1	RESISTOR,FXD 900 OHM 0.05% 1/8W MF	28480	0698-2207
A4R28	0683-0565	0	1	RESISTOR 5.6 5% .25W FC TC=-400/+500	01121	C85605
A4R29	0698-2342	6		RESISTOR 450 +-1% .125W	28480	0698-2342
A4R29	0698-4431	8	1	RESISTOR 2.05K 1% .125W F TC=0+-100	24546	C4-1/8-T0=2051-F
A4R30	0683-0275	9	1	RESISTOR 2.7 5% .25W FC TC=-400/+500	01121	C82755
A4R31	0698-2342	6		RESISTOR 450 +-1% .125W	28480	0698-2342
A4R32	0698-3132	4	2	RESISTOR 261 1% .125W F TC=0+-100	24546	C4-1/8-T0=2610-F
A4R33	0757-0280	3		RESISTOR 1K 1% .125W F TC=0+-100	24546	C4-1/8-T0=1001-F
A4R34	0683-1015	7		RESISTOR 100 5% .25W FC TC=-400/+500	01121	C81015
A4R35	0683-1015	7		RESISTOR 100 5% .25W FC TC=-400/+500	01121	C81015
A4R36	0683-1045	3		RESISTOR 100K 5% .25W FC TC=-400/+800	01121	C81045
A4R37	0683-1035	1		RESISTOR 10K 5% .25W FC TC=-400/+700	01121	C81035
A4R38	0698-3155	4		RESISTOR 4.64K 1% .125W F TC=0+-100	24546	C4-1/8-T0=4641-F
A4R39	0683-3335	4		RESISTOR 33K 5% .25W FC TC=-400/+800	01121	C83335
A4R40	0683-2245	7		RESISTOR 220K 5% .25W FC TC=-800/+900	01121	C82245
A4R41	0683-2245	7		RESISTOR 220K 5% .25W FC TC=-800/+900	01121	C82245
A4R42	0683-2245	7		RESISTOR 220K 5% .25W FC TC=-800/+900	01121	C82245
A4R43	0683-2245	7		RESISTOR 220K 5% .25W FC TC=-800/+900	01121	C82245
A4R44	0683-2245	7		RESISTOR 220K 5% .25W FC TC=-800/+900	01121	C82245
A4R45	0683-2245	7		RESISTOR 220K 5% .25W FC TC=-800/+900	01121	C82245
A4R46	0683-1035	1		RESISTOR 10K 5% .25W FC TC=-400/+700	01121	C81035
A4R47	0683-2245	7		RESISTOR 220K 5% .25W FC TC=-800/+900	01121	C82245
A4R48	0683-2245	7		RESISTOR 220K 5% .25W FC TC=-800/+900	01121	C82245
A4R49	0683-2245	7		RESISTOR 220K 5% .25W FC TC=-800/+900	01121	C82245

See introduction to this section for ordering information  
\*Indicates factory selected value

Table 6-3. Replaceable Parts (Cont'd).

Reference Designation	HP Part Number	C D	Qty	Description	Mfr Code	Mfr Part Number
A4R50	0757-0442	9		RESISTOR 10K 1% .125W F TC=0+100	24546	C4-1/8-T0-1002-F
A4R51	0757-0465	0		RESISTOR 100K 1% .125W F TC=0+100	24546	C4-1/8-T0-1003-F
A4R52	0757-0488	3		RESISTOR 909K 1% .125W F TC=0+100	28480	0757-0488
A4R53	0698-3159	5		RESISTOR 26.1K 1% .125W F TC=0+100	24546	C4-1/8-T0-2612-F
A4R54	0698-3155	1		RESISTOR 4.64K 1% .125W F TC=0+100	24546	C4-1/8-T0-4641-F
A4R55	2100-3353	8		RESISTOR-TMR 20K 10% C SIDE-ADJ 1-TRN	32997	3386X-Y46-203
A4R56	0683-3335	8		RESISTOR 33K 5% .25W FC TC=-400/+800	01121	C83335
A4R57	0683-1035	1		RESISTOR 10K 5% .25W FC TC=-400/+700	01121	C81035
A4R58	0698-4439	0	1	RESISTOR 3.24K 1% .125W F TC=0+100	24546	C4-1/8-T0-3241-F
A4R59	0757-4276	9		RESISTOR 1.78K 1% .125W F TC=0+100	24546	C4-1/8-T0-1781-F
A4R60	0698-4467	0	1	RESISTOR 1.05K 1% .125W F TC=0+100	24546	C4-1/8-T0-1051-F
A4R61	0757-0417	0	1	RESISTOR 562 1% .125W F TC=0+100	24546	C4-1/8-T0-562R-F
A4R62	0757-0433	A	1	RESISTOR 3.32K 1% .125W F TC=0+100	24546	C4-1/8-T0-3321-F
A4R63	0698-3155	1		RESISTOR 4.64K 1% .125W F TC=0+100	24546	C4-1/8-T0-4641-F
A4R64	0698-3155	1		RESISTOR 4.64K 1% .125W F TC=0+100	24546	C4-1/8-T0-4641-F
A4R65	1A10-0207	9	3	NETWORK-RES 8-PIN-SIP .1-PIN-SPCG	01121	208A223
A4R66	1A10-0207	9		NETWORK-RES 8-PIN-SIP .1-PIN-SPCG	01121	208A223
A4R67	1A10-0207	9		NETWORK-RES 8-PIN-SIP .1-PIN-SPCG	01121	208A223
A4R68	0683-1045	3		RESISTOR 100K 5% .25W FC TC=-400/+800	01121	C81045
A4R69	0683-1035	1		RESISTOR 10K 5% .25W FC TC=-400/+700	01121	C81035
A4R70	0698-3152	8	1	RESISTOR 3.48K 1% .125W F TC=0+100	24546	C4-1/8-T0-3481-F
A4R71	0683-2245	7		RESISTOR 220K 5% .25W FC TC=-800/+900	01121	C82245
A4R72	0683-2245	7		RESISTOR 220K 5% .25W FC TC=-800/+900	01121	C82245
A4R73	0683-2245	7		RESISTOR 220K 5% .25W FC TC=-800/+900	01121	C82245
A4R74	0683-2245	7		RESISTOR 220K 5% .25W FC TC=-800/+900	01121	C82245
A4R75	0757-0482	7	1	RESISTOR 511K 1% .125W F TC=0+100	28480	0757-0482
A4R76	0698-3132	4		RESISTOR 261 1% .125W F TC=0+100	24546	C4-1/8-T0-2610-F
A4R77	0757-0280	3		RESISTOR 1K 1% .125W F TC=0+100	24546	C4-1/8-T0-1001-F
A4R78	0683-1015	7		RESISTOR 100 5% .25W FC TC=-400/+500	01121	C81015
A4R79	0683-1015	7		RESISTOR 100 5% .25W FC TC=-400/+500	01121	C81015
A4R80	0757-1094	9		RESISTOR 1.47K 1% .125W F TC=0+100	24546	C4-1/8-T0-1471-F
A4R81	0683-4725	2		RESISTOR 4.7K 5% .25W FC TC=-400/+700	01121	C84725
A4R82	0683-4725	2		RESISTOR 4.7K 5% .25W FC TC=-400/+700	01121	C84725
A4R83	0683-4725	2		RESISTOR 4.7K 5% .25W FC TC=-400/+700	01121	C84725
A4R84	0683-4725	2		RESISTOR 4.7K 5% .25W FC TC=-400/+700	01121	C84725
A4R85	0757-0443	0	1	RESISTOR 11K 1% .125W F TC=0+100	24546	C4-1/8-T0-1102-F
A4R86	0757-0440	7		RESISTOR 7.5K 1% .125W F TC=0+100	24546	C4-1/8-T0-7501-F
A4R87	0698-0083	8		RESISTOR 1.96K 1% .125W F TC=0+100	24546	C4-1/8-T0-1961-F
A4R88	0698-0084	9		RESISTOR 2.15K 1% .125W F TC=0+100	24546	C4-1/8-T0-2151-F
A4R90	0683-1015	7		RESISTOR 100 5% .25W FC TC=-400/+500	01121	C81015
A4T1	9100-0878	5		TRANSFORMER, SIGNAL	28480	9100-0878
A4T2	9100-0855	6		TRANSFORMER, PULSE	28480	9100-0855
A4T3	9100-0878	5		TRANSFORMER, SIGNAL	28480	9100-0878
A4T4	9100-0855	6		TRANSFORMER, PULSE	28480	9100-0855
A4T5	9100-0855	6		TRANSFORMER, PULSE	28480	9100-0855
A4U1	5080-3066	3		IC-LIN SELECTED	27014	
A4U2	1826-0081	0		OP AMP WB T0-99	27014	LM318M
A4U3	1826-0081	0		OP AMP WB T0-99	27014	LM318M
A4U4	1826-0081	0		OP AMP WB T0-99	27014	LM318M
A4U5	1826-0081	0		OP AMP WB T0-99	27014	LM318M
A4U6	1826-0081	0		OP AMP WB T0-99	27014	LM318M
A4U7	1826-0319	7		OP AMP BIPEY T0-99	27014	LF356M
A4U8	5080-3066	3		IC-LIN SELECTED	27014	
A4U9	1826-0138	8		COMPARATOR GP QUAD 14-DIP-P	04713	MLM339P
A4U10	1826-0138	8		COMPARATOR GP QUAD 14-DIP-P	04713	MLM339P
A4U11	1826-0138	8		COMPARATOR GP QUAD 14-DIP-P	04713	MLM339P
A4U12	1826-0138	8		COMPARATOR GP QUAD 14-DIP-P	04713	MLM339P
A4U13	1826-0138	8		COMPARATOR GP QUAD 14-DIP-P	04713	MLM339P
A4U14	1826-0346	0	1	OP AMP GP DUAL 8-DIP-P	27014	LM358N
				A4 MISCELLANEOUS PARTS		
A4Z1	04274-26504	7		PC BOARD, BLANK	28480	04274-26504
A5	04274-66505	2	1	A/D CONVERTER BOARD ASSEMBLY	28480	04274-66505
ASC1	0150-0121	5		CAPACITOR-FXD .1UF +80-20% 50VDC CER	28480	0150-0121
ASC2	0150-0121	5		CAPACITOR-FXD .1UF +80-20% 50VDC CER	28480	0150-0121
ASC3	0150-0121	5		CAPACITOR-FXD .1UF +80-20% 50VDC CER	28480	0150-0121
ASC4	0160-2204	0	2	CAPACITOR-FXD 100PF +-5% 300VDC MICA	28480	0160-2204
ASC5	0160-0153	4	2	CAPACITOR-FXD 1000PF +-10% 200VDC POLYE	28480	0160-0153
ASC6	0160-0153	4		CAPACITOR-FXD 1000PF +-10% 200VDC POLYE	28480	0160-0153
ASC7	0150-0121	5		CAPACITOR-FXD .1UF +80-20% 50VDC CER	28480	0150-0121
ASC8	0150-0121	5		CAPACITOR-FXD .1UF +80-20% 50VDC CER	28480	0150-0121
ASC9	0160-1674	6	1	CAPACITOR .33uF +-5% 200VDC	28480	0160-1674
ASC10	0160-0134	1		CAPACITOR-FXD 220PF +-5% 300VDC MICA	28480	0160-0134

See introduction to this section for ordering information  
\*Indicates factory selected value

Table 6-3. Replaceable Parts (Cont'd).

Reference Designation	HP Part Number	C D	Qty	Description	Mfr Code	Mfr Part Number
A5C11	0150-0121	5	5	CAPACITOR-FXD .1UF +80-20% 50VDC CER	28480	0150-0121
A5C12	0150-0121	5		CAPACITOR-FXD .1UF +80-20% 50VDC CER	28480	0150-0121
A5C13	0180-1083	3		CAPACITOR-FXD 33UF +75-10% 25VDC	28480	0180-1083
A5C14	0150-0121	5		CAPACITOR-FXD .1UF +80-20% 50VDC CER	28480	0150-0121
A5C15	0150-0121	5		CAPACITOR-FXD .1UF +80-20% 50VDC CER	28480	0150-0121
A5C16	0150-0121	5	5	CAPACITOR-FXD .1UF +80-20% 50VDC CER	28480	0150-0121
A5C17	0150-0121	5		CAPACITOR-FXD .1UF +80-20% 50VDC CER	28480	0150-0121
A5C18	0150-0121	5		CAPACITOR-FXD .1UF +80-20% 50VDC CER	28480	0150-0121
A5C19	0150-0121	5		CAPACITOR-FXD .1UF +80-20% 50VDC CER	28480	0150-0121
A5C20	0150-0121	5		CAPACITOR-FXD .1UF +80-20% 50VDC CER	28480	0150-0121
A5C21	0160-3456	6	7	CAPACITOR-FXD 1000PF +-10% 1KVDC CER	28480	0160-3456
A5C22	0150-0121	5		CAPACITOR-FXD .1UF +80-20% 50VDC CER	28480	0150-0121
A5C23	0150-0121	5		CAPACITOR-FXD .1UF +80-20% 50VDC CER	28480	0150-0121
A5C24	0180-1083	3		CAPACITOR-FXD 33UF +75-10% 25VDC	28480	0180-1083
A5C25	0180-0228	6		CAPACITOR-FXD 22UF+-10% 15VDC TA	56289	150D226X901582
A5C26	0180-0228	6	6	CAPACITOR-FXD 22UF+-10% 15VDC TA	56289	150D226X901582
A5C27	0180-1083	3		CAPACITOR-FXD 33UF +75-10% 25VDC	28480	0180-1083
A5C28	0180-1083	3		CAPACITOR-FXD 33UF +75-10% 25VDC	28480	0180-1083
A5C29	0180-1083	3		CAPACITOR-FXD 33UF +75-10% 25VDC	28480	0180-1083
A5C30	0160-3456	6		CAPACITOR-FXD 1000PF +-10% 1KVDC CER	28480	0160-3456
A5C31	0160-3456	6	6	CAPACITOR-FXD 1000PF +-10% 1KVDC CER	28480	0160-3456
A5C32	0160-3456	6		CAPACITOR-FXD 1000PF +-10% 1KVDC CER	28480	0160-3456
A5CR1	1902-0049	2	3	DIODE-ZNR 6.19V 5% DO-7 PD=.4W TC=-.022X	28480	1902-0049
A5CR2	1901-0040	1		DIODE-SWITCHING 30V 50MA 2NS DO-35	28480	1901-0040
A5CR3	1901-0040	1		DIODE-SWITCHING 30V 50MA 2NS DO-35	28480	1901-0040
A5CR4	1901-1011	8		DIODE-ARRAY VF DIFF#5MV	28480	1901-1011
A5CR5	1901-0040	1		DIODE-SWITCHING 30V 50MA 2NS DO-35	28480	1901-0040
A5CR6	1901-0040	1	6	DIODE-SWITCHING 30V 50MA 2NS DO-35	28480	1901-0040
A5CR7	1901-0040	1		DIODE-SWITCHING 30V 50MA 2NS DO-35	28480	1901-0040
A5CR8	1901-0040	1		DIODE-SWITCHING 30V 50MA 2NS DO-35	28480	1901-0040
A5CR9	1902-3062	5		DIODE-ZNR 3.92V 5% DO-7 PD=.4W TC=-.049X	28480	1902-3062
A5CR10	1902-3062	5		DIODE-ZNR 3.92V 5% DO-7 PD=.4W TC=-.049X	28480	1902-3062
A5CR11	1902-3062	5		DIODE-ZNR 3.92V 5% DO-7 PD=.4W TC=-.049X	28480	1902-3062
A5CR12	1902-3062	5	DIODE-ZNR 3.92V 5% DO-7 PD=.4W TC=-.049X	28480	1902-3062	
A5CR13	1902-3062	5	DIODE-ZNR 3.92V 5% DO-7 PD=.4W TC=-.049X	28480	1902-3062	
A5CR14	1902-3062	5	DIODE-ZNR 3.92V 5% DO-7 PD=.4W TC=-.049X	28480	1902-3062	
A5CR15	1901-0040	1	DIODE-SWITCHING 30V 50MA 2NS DO-35	28480	1901-0040	
A5CR16	1901-0040	1	DIODE-SWITCHING 30V 50MA 2NS DO-35	28480	1901-0040	
A5L1	9140-0158	6	9	COIL-MLD 1UH 10% Q#32 .095DX,25LG-NOM	28480	9140-0158
A5L2	9140-0158	6		COIL-MLD 1UH 10% Q#32 .095DX,25LG-NOM	28480	9140-0158
A5L4	9140-0158	6		COIL-MLD 1UH 10% Q#32 .095DX,25LG-NOM	28480	9140-0158
A5L5	9140-0158	6		COIL-MLD 1UH 10% Q#32 .095DX,25LG-NOM	28480	9140-0158
A5L6	9140-0158	6		COIL-MLD 1UH 10% Q#32 .095DX,25LG-NOM	28480	9140-0158
A5L7	9140-0158	6		COIL-MLD 1UH 10% Q#32 .095DX,25LG-NOM	28480	9140-0158
A5L8	9140-0158	6	COIL-MLD 1UH 10% Q#32 .095DX,25LG-NOM	28480	9140-0158	
A5L9	9140-0158	6	COIL-MLD 1UH 10% Q#32 .095DX,25LG-NOM	28480	9140-0158	
A5L10	9140-0158	6	COIL-MLD 1UH 10% Q#32 .095DX,25LG-NOM	28480	9140-0158	
A5L11	9140-0179	1	2	COIL-MLD 22UH 10% Q#75 .155DX,375LG-NOM	28480	9140-0179
A5L12	9140-0179	1		COIL-MLD 22UH 10% Q#75 .155DX,375LG-NOM	28480	9140-0179
A5Q1	1855-0111	8	20	TRANSISTOR J-FET N-CHAN Si	28480	1855-0111
A5Q2	1855-0111	8		TRANSISTOR J-FET N-CHAN Si	28480	1855-0111
A5Q3	1855-0111	8		TRANSISTOR J-FET N-CHAN Si	28480	1855-0111
A5Q4	1855-0111	8		TRANSISTOR J-FET N-CHAN Si	28480	1855-0111
A5Q5	1855-0111	8		TRANSISTOR J-FET N-CHAN Si	28480	1855-0111
A5Q6	1855-0111	8	8	TRANSISTOR J-FET N-CHAN Si	28480	1855-0111
A5Q7	1855-0111	8		TRANSISTOR J-FET N-CHAN Si	28480	1855-0111
A5Q8	1855-0111	8		TRANSISTOR J-FET N-CHAN Si	28480	1855-0111
A5Q9	1855-0111	8		TRANSISTOR J-FET N-CHAN Si	28480	1855-0111
A5Q10	1855-0111	8		TRANSISTOR J-FET N-CHAN Si	28480	1855-0111
A5Q11	1855-0111	8	TRANSISTOR J-FET N-CHAN Si	28480	1855-0111	
A5Q12	1855-0111	8	TRANSISTOR J-FET N-CHAN Si	28480	1855-0111	
A5R1	0698-3151	7	4	RESISTOR 2.87K 1% .125W F TC#0+-100	24546	C4-1/8-T0-2871-F
A5R2	0698-6360	6		RESISTOR 10K 1% .125W F TC#0+-25	28480	0698-6360
A5R3	2100-0552	3		RESISTOR-TRM 50 10% C SIDE-ADJ 1-TRN	28480	2100-0552
A5R4	0698-6360	6		RESISTOR 10K 1% .125W F TC#0+-25	28480	0698-6360
A5R5	0698-3155	1		RESISTOR 4.64K 1% .125W F TC#0+-100	24546	C4-1/8-T0-4641-F
A5R6	0757-0199	3	2	RESISTOR 21.5K 1% .125W F TC#0+-100	24546	C4-1/8-T0-2152-F
A5R7	0698-3156	2		RESISTOR 14.7K 1% .125W F TC#0+-100	24546	C4-1/8-T0-1472-F
A5R8	0698-3161	9		RESISTOR 38.3K 1% .125W F TC#0+-100	24546	C4-1/8-T0-3832-F
A5R9	0698-4158	1		RESISTOR-FXD 100K +-0.1% .125W FILM	28480	
A5R10	0698-4158	1		RESISTOR-FXD 100K +-0.1% .125W FILM	28480	
A5R11	0698-3161	9	9	RESISTOR 38.3K 1% .125W F TC#0+-100	24546	C4-1/8-T0-3832-F
A5R12	0757-0442	9		RESISTOR 10K 1% .125W F TC#0+-100	24546	C4-1/8-T0-1002-F
A5R13	0757-0440	7		RESISTOR 7.5K 1% .125W F TC#0+-100	24546	C4-1/8-T0-7501-F
A5R14	0757-0440	7		RESISTOR 7.5K 1% .125W F TC#0+-100	24546	C4-1/8-T0-7501-F
A5R15	0698-0084	9		RESISTOR 2.15K 1% .125W F TC#0+-100	24546	C4-1/8-T0-2151-F

See introduction to this section for ordering information  
\*Indicates factory selected value

Table 6-3. Replaceable Parts (Cont'd).

Reference Designation	HP Part Number	C D	Qty	Description	Mfr Code	Mfr Part Number
45R16	0698-0084	9	2	RESISTOR 2.15K 1% .125W F TC=0+-100	24546	C4=1/8-T0-2151-F
45R17	0698-3268	7		RESISTOR 11.5K 1% .125W F TC=0+-100	24546	C4=1/8-T0-1152-F
45R18	0698-3268	7		RESISTOR 11.5K 1% .125W F TC=0+-100	24546	C4=1/8-T0-1152-F
45R19	0757-0442	9		RESISTOR 10K 1% .125W F TC=0+-100	24546	C4=1/8-T0-1002-F
45R20	0698-3136	8		RESISTOR 17.8K 1% .125W F TC=0+-100	24546	C4=1/8-T0-1782-F
45R21	0698-3155	1	1	RESISTOR 4.64K 1% .125W F TC=0+-100	24546	C4=1/8-T0-4641-F
45R22	0757-0280	3		RESISTOR 1K 1% .125W F TC=0+-100	24546	C4=1/8-T0-1001-F
45R23	0757-0465	6		RESISTOR 100K 1% .125W F TC=0+-100	24546	C4=1/8-T0-1003-F
45R24	0698-3155	1		RESISTOR 4.64K 1% .125W F TC=0+-100	24546	C4=1/8-T0-4641-F
45R25	0757-0279	7		RESISTOR 3.16KΩ +-1% .125W FILM	24546	
45R26	0757-0279	7	7	RESISTOR 3.16KΩ +-1% .125W FILM	24546	
45R27	0757-0279	7		RESISTOR 3.16KΩ +-1% .125W FILM	24546	
45R28	0757-0279	7		RESISTOR 3.16KΩ +-1% .125W FILM	24546	
45R29	0757-0279	7		RESISTOR 3.16KΩ +-1% .125W FILM	24546	
45R30	0757-0279	7		RESISTOR 3.16KΩ +-1% .125W FILM	24546	
45R31	0698-3155	1	6	RESISTOR 4.64K 1% .125W F TC=0+-100	24546	C4=1/8-T0-4641-F
45R32	0698-3155	1		RESISTOR 4.64K 1% .125W F TC=0+-100	24546	C4=1/8-T0-4641-F
45R33	0698-3153	9		RESISTOR 3.83K 1% .125W F TC=0+-100	24546	C4=1/8-T0-3831-F
45R34	0698-3153	9		RESISTOR 3.83K 1% .125W F TC=0+-100	24546	C4=1/8-T0-3831-F
45R35	0698-3153	9		RESISTOR 3.83K 1% .125W F TC=0+-100	24546	C4=1/8-T0-3831-F
45R36	0698-3153	9	9	RESISTOR 3.83K 1% .125W F TC=0+-100	24546	C4=1/8-T0-3831-F
45R37	0698-3153	9		RESISTOR 3.83K 1% .125W F TC=0+-100	24546	C4=1/8-T0-3831-F
45R38	0698-3153	9		RESISTOR 3.83K 1% .125W F TC=0+-100	24546	C4=1/8-T0-3831-F
45R39	0698-2346	0		RESISTOR 29.8K +-1% .1W	28480	0698-2346
45R40	0698-2345	9		RESISTOR 42.2K +-1% .1W	28480	0698-2345
45R41	0698-2345	9	9	RESISTOR 42.2K +-1% .1W	28480	0698-2345
45R42	0698-2346	0		RESISTOR 29.8K +-1% .1W	28480	0698-2346
45R43	0757-0276	2		RESISTOR 61.9Ω +-1% 0.125W FILM	28480	
45R44	0698-6360	6		RESISTOR 10K 1% .125W F TC=0+-25	28480	0698-6360
45R45	0698-6360	6		RESISTOR 10K 1% .125W F TC=0+-25	28480	0698-6360
45R46	0698-3160	8	8	RESISTOR 31.6K 1% .125W F TC=0+-100	24546	C4=1/8-T0-3162-F
45R47	0698-3160	8		RESISTOR 31.6K 1% .125W F TC=0+-100	24546	C4=1/8-T0-3162-F
45R48	0698-3156	2		RESISTOR 14.7K 1% .125W F TC=0+-100	24546	C4=1/8-T0-1472-F
45R49	0757-0123	3		RESISTOR 34.8K 1% .125W F TC=0+-100	28480	0757-0123
45R50	0757-0401	0		RESISTOR 100 1% .125W F TC=0+-100	24546	C4=1/8-T0-101-F
45R51	0698-3155	1	1	RESISTOR 4.64K 1% .125W F TC=0+-100	24546	C4=1/8-T0-4641-F
45R52	0698-3155	1		RESISTOR 4.64K 1% .125W F TC=0+-100	24546	C4=1/8-T0-4641-F
45R53	0757-0465	6		RESISTOR 100K 1% .125W F TC=0+-100	24546	C4=1/8-T0-1003-F
45R54	0757-0465	6		RESISTOR 100K 1% .125W F TC=0+-100	24546	C4=1/8-T0-1003-F
45R55	0757-0199	3		RESISTOR 21.5K 1% .125W F TC=0+-100	24546	C4=1/8-T0-2152-F
45R56	0698-3155	1	RESISTOR 4.64K 1% .125W F TC=0+-100	24546	C4=1/8-T0-4641-F	
45U1	1820-0203	6	1	OP AMP GP T0-99	01928	CA741CT
45U2	1826-0035	4		OP AMP LOW-DRIPT T0-99	27014	LM308AM
45U3	1820-0203	6		OP AMP GP T0-99	01928	CA741CT
45U4	1826-0319	7		OP AMP BIFET T0-99	27014	LF356H
45U5	1826-0081	0		OP AMP WB T0-99	27014	LM318H
45U6	1820-1112	8	11	IC FF TTL LS D-TYPE POS-EDGE-TRIG	01295	8N74LS74N
45U7	1820-1112	8		IC FF TTL LS D-TYPE POS-EDGE-TRIG	01295	8N74LS74N
45U8	1826-0081	0		OP AMP WB T0-99	27014	LM318H
45U9	1826-0319	0		IC-LINEAR OP-AMP JFET INPUT	27014	
45U10	1826-0138	8		COMPARATOR GP QUAD 14-DIP-P	04713	MLM339P
45U11	1820-1195	7	1	IC FF TTL LS D-TYPE POS-EDGE-TRIG COM	01295	8N74LS175N
45U12	1826-0210	7		COMPARATOR MS 14-DIP-P	27014	LM361N
45U13	1820-1210	7		IC GATE TTL LS AND-OR-INV DUAL 2-INP	01295	8N74LS51N
45U14	1820-1210	7		IC GATE TTL LS AND-OR-INV DUAL 2-INP	01295	8N74LS51N
45U15	1820-1199	1		IC INV TTL LS HEX 1-INP	01295	8N74LS04N
45U16	1820-1730	6	6	IC FF TTL LS D-TYPE POS-EDGE-TRIG COM	01295	8N74LS273N
45U17	1820-1730	6		IC FF TTL LS D-TYPE POS-EDGE-TRIG COM	01295	8N74LS273N
45U18	1820-1730	6		IC FF TTL LS D-TYPE POS-EDGE-TRIG COM	01295	8N74LS273N
45U19	1820-1112	8		IC FF TTL LS D-TYPE POS-EDGE-TRIG	01295	8N74LS74N
45U20	1820-1452	5		IC CNTR TTL LS BIN SYNCHRO POS-EDGE-TRIG	01295	8N74LS163AN
45A1	8159-0005	0	19	WIRE 22AWG W PVC 1X22 80C	28480	8159-0005
				A5 MISCELLANEOUS PARTS		
	04274-26505	8	1	PC BOARD, BLANK	28480	04274-26505
46	04274-66506	3		OSCILLATOR BOARD ASSEMBLY	28480	04274-66506
46C1	0180-1735	2	2	CAPACITOR-FXD .22UF+-10% 35VDC TA	56289	150D224X9035A2
46C2	0180-1735	2		CAPACITOR-FXD .22UF+-10% 35VDC TA	56289	150D224X9035A2
46C3	0160-0127	2		CAPACITOR-FXD 1UF +-20% 25VDC CER	28480	0160-0127
46C4	0160-2209	5		CAPACITOR-FXD 360PF +-5% 300VDC MICA	28480	0160-2209
46C5	0180-1085	5		CAPACITOR, FXD 4.7 UF 16VDCW TA	28480	0180-1085

See introduction to this section for ordering information  
\*Indicates factory selected value



Table 6-3. Replaceable Parts (Cont'd).

Reference Designation	HP Part Number	C D	Qty	Description	Mfr Code	Mfr Part Number
A6C6	0180-1704	5	1	CAPACITOR-FXD 47UF +-10% 6VDC TA	56289	150D476X900682
A6C7	0180-0127	2		CAPACITOR-FXD 1UF +-20% 25VDC CER	28480	0180-0127
A6C8	0180-0127	2		CAPACITOR-FXD 1UF +-20% 25VDC CER	28480	0180-0127
A6C9	0180-0127	2		CAPACITOR-FXD 1UF +-20% 25VDC CER	28480	0180-0127
A6C10	0180-0127	2		CAPACITOR-FXD 1UF +-20% 25VDC CER	28480	0180-0127
A6C11	0180-0163	6	2	CAPACITOR-FXD .033UF +-10% 200VDC POLYE	28480	0180-0163
A6C12	0180-0155	6	2	CAPACITOR-FXD 3300PF +-10% 200VDC POLYE	28480	0180-0155
A6C13	0180-2209	5		CAPACITOR-FXD 360PF +-5% 300VDC MICA	28480	0180-2209
A6C14	0180-2055	9		CAPACITOR-FXD .01UF +80-20% 100VDC CER	28480	0180-2055
A6C15	0180-2055	9		CAPACITOR-FXD .01UF +80-20% 100VDC CER	28480	0180-2055
A6C16	0180-2219	7	2	CAPACITOR-FXD 1100PF +-5% 300VDC MICA	28480	0180-2219
A6C17	0180-0161	4		CAPACITOR-FXD .01UF +-10% 200VDC POLYE	28480	0180-0161
A6C18	0180-0168	1	2	CAPACITOR-FXD .1UF +-10% 200VDC POLYE	28480	0180-0168
A6C19	0180-1085	5		CAPACITOR, FXD 4.7 UF 16VDC TA	28480	0180-1085
A6C20	0180-1050	4	14	CAPACITOR, FXD 100 UF 25VDC TA	28480	0180-1050
A6C21	0180-2940	1		CAPACITOR-FXD 470PF +-5% 300VDC MICA	28480	0180-2940
A6C22	0180-0134	1		CAPACITOR-FXD 220PF +-5% 300VDC MICA	28480	0180-0134
A6C23	0140-0192	9	1	CAPACITOR-FXD 68PF +-5% 300VDC MICA	72136	DM15E680J0300*V1CR
A6C27	0180-2055	9		CAPACITOR-FXD .01UF +80-20% 100VDC CER	28480	0180-2055
A6C28	0180-2055	9		CAPACITOR-FXD .01UF +80-20% 100VDC CER	28480	0180-2055
A6C29	0180-2055	9		CAPACITOR-FXD .01UF +80-20% 100VDC CER	28480	0180-2055
A6C30	0180-1901	6	1	CAPACITOR-FXD 2.2UF +-20% 25VDC CER	28480	0180-1901
A6C31	0180-2055	9		CAPACITOR-FXD .01UF +80-20% 100VDC CER	28480	0180-2055
A6C32	0180-2055	9		CAPACITOR-FXD .01UF +80-20% 100VDC CER	28480	0180-2055
A6C33	0180-0134	1		CAPACITOR-FXD 220PF +-5% 300VDC MICA	28480	0180-0134
A6C35	0180-0374	3		CAPACITOR-FXD 10UF +-10% 20VDC TA	56289	150D106X902082
A6C36	0180-2055	9		CAPACITOR-FXD .01UF +80-20% 100VDC CER	28480	0180-2055
A6C37	0180-2055	9		CAPACITOR-FXD .01UF +80-20% 100VDC CER	28480	0180-2055
A6C38	0180-2055	9		CAPACITOR-FXD .01UF +80-20% 100VDC CER	28480	0180-2055
A6C39	0160-0168	9	1	CAPACITOR-FXD 0.1UF +-10% 200VDC POLYE	28480	0180-2055
A6C40	0160-0161	5	1	CAPACITOR-FXD 0.01UF +-10% 200VDC POLYE	28480	0180-2055
A6C41	0160-0153	5	1	CAPACITOR-FXD 1000PF +-10% 200VDC POLYE	28480	0180-2055
A6C42	0180-2055	9		CAPACITOR-FXD .01UF +80-20% 100VDC CER	28480	0180-2055
A6C43	0180-2055	9		CAPACITOR-FXD .01UF +80-20% 100VDC CER	28480	0180-2055
A6C44	0180-2055	9		CAPACITOR-FXD .01UF +80-20% 100VDC CER	28480	0180-2055
A6C45	0180-2055	9		CAPACITOR-FXD .01UF +80-20% 100VDC CER	28480	0180-2055
A6C46	0180-0163	6		CAPACITOR-FXD .033UF +-10% 200VDC POLYE	28480	0180-0163
A6C47	0180-0155	6		CAPACITOR-FXD 3300PF +-10% 200VDC POLYE	28480	0180-0155
A6C48	0180-2209	5		CAPACITOR-FXD 360PF +-5% 300VDC MICA	28480	0180-2209
A6C49	0180-2055	9		CAPACITOR-FXD .01UF +80-20% 100VDC CER	28480	0180-2055
A6C50	0180-2055	9		CAPACITOR-FXD .01UF +80-20% 100VDC CER	28480	0180-2055
A6C51	0180-2219	7		CAPACITOR-FXD 1100PF +-5% 300VDC MICA	28480	0180-2219
A6C52	0180-0161	4		CAPACITOR-FXD .01UF +-10% 200VDC POLYE	28480	0180-0161
A6C53	0180-0168	1		CAPACITOR-FXD .1UF +-10% 200VDC POLYE	28480	0180-0168
A6C54	0180-0374	3		CAPACITOR-FXD 10UF +-10% 20VDC TA	56289	150D106X902082
A6C55	0180-2055	9		CAPACITOR-FXD .01UF +80-20% 100VDC CER	28480	0180-2055
A6C56	0180-2055	9		CAPACITOR-FXD .01UF +80-20% 100VDC CER	28480	0180-2055
A6C57	0180-0374	3		CAPACITOR-FXD 10UF +-10% 20VDC TA	56289	150D106X902082
A6C58	0180-2055	9		CAPACITOR-FXD .01UF +80-20% 100VDC CER	28480	0180-2055
A6C70	0160-2266	1		CAPACITOR-FXD 24PF +-5% CER 500VDC	28480	0180-2055
A6CP1	1990-0104	5	1	PHOTOCELL LAMP	28480	1990-0104
A6CR1	1901-0040	1		DIODE-SWITCHING 30V 50MA 2NS DO-35	28480	1901-0040
A6CR2	1901-0040	1		DIODE-SWITCHING 30V 50MA 2NS DO-35	28480	1901-0040
A6CR3	1902-0041	4	2	DIODE-ZNR 5.11V 5X DO-7 PD=.4W TC=-.009%	28480	1902-0041
A6CR4	1901-0518	8	5	DIODE-SCHOTTKY	28480	1901-0518
A6CR5	1901-0518	8		DIODE-SCHOTTKY	28480	1901-0518
A6CR6	1901-0518	8		DIODE-SCHOTTKY	28480	1901-0518
A6CR7	1901-0040	1		DIODE-SWITCHING 30V 50MA 2NS DO-35	28480	1901-0040
A6CR8	1901-0040	1		DIODE-SWITCHING 30V 50MA 2NS DO-35	28480	1901-0040
A6CR9	1901-0040	1		DIODE-SWITCHING 30V 50MA 2NS DO-35	28480	1901-0040
A6CR10	1901-0040	1		DIODE-SWITCHING 30V 50MA 2NS DO-35	28480	1901-0040
A6CR11	1901-0040	1		DIODE-SWITCHING 30V 50MA 2NS DO-35	28480	1901-0040
A6CR12	1901-0040	1		DIODE-SWITCHING 30V 50MA 2NS DO-35	28480	1901-0040
A6CR13	1901-0040	1		DIODE-SWITCHING 30V 50MA 2NS DO-35	28480	1901-0040
A6CR14	1902-0049	2		DIODE-ZNR 6.19V 5X DO-7 PD=.4W TC=-.022%	28480	1902-0049
A6CR15	1901-0040	1		DIODE-SWITCHING 30V 50MA 2NS DO-35	28480	1901-0040
A6CR16	1901-0040	1		DIODE-SWITCHING 30V 50MA 2NS DO-35	28480	1901-0040
A6CR17	1901-0040	1		DIODE-SWITCHING 30V 50MA 2NS DO-35	28480	1901-0040
A6CR18	1901-0040	1		DIODE-SWITCHING 30V 50MA 2NS DO-35	28480	1901-0040
A6CR19	1901-0040	1		DIODE-SWITCHING 30V 50MA 2NS DO-35	28480	1901-0040
A6CR20	1901-0040	1		DIODE-SWITCHING 30V 50MA 2NS DO-35	28480	1901-0040
A6CR21	1901-0040	1		DIODE-SWITCHING 30V 50MA 2NS DO-35	28480	1901-0040
A6CR22	1902-0049	2		DIODE-ZNR 6.19V 5X DO-7 PD=.4W TC=-.022%	28480	1902-0049
A6CR23	1901-0040	1		DIODE-SWITCHING 30V 50MA 2NS DO-35	28480	1901-0040

See introduction to this section for ordering information  
\*Indicates factory selected value

Table 6-3. Replaceable Parts (Cont'd).

Reference Designation	HP Part Number	C D	Qty	Description	Mfr Code	Mfr Part Number	
A6L1	9140-0114	4	3	COIL-MLD 10UH 10% Q#55 .155DX,375LG-NOM	28480	9140-0114	
A6L2	9140-0129	1		COIL-MLD 220UH 5% Q#65 .155DX,375LG-NOM	28480	9140-0129	
A6L3	9140-0129	1		COIL-MLD 220UH 5% Q#65 .155DX,375LG-NOM	28480	9140-0129	
A6L4	9140-0114	4		COIL-MLD 10UH 10% Q#55 .155DX,375LG-NOM	28480	9140-0114	
A6L5	9140-0114	4		COIL-MLD 10UH 10% Q#55 .155DX,375LG-NOM	28480	9140-0114	
A6L6	9100-3139	5	8	COIL 75UH 15% .5DX,875LG-NOM	28480	9100-3139	
A6Q1	1854-0215	1	7	TRANSISTOR NPN SI PD#350MW FT#300MHZ	04713	2N3904	
A6Q2	1855-0091	3		TRANSISTOR J-FET N-CHAN D-MODE SI	28480	1855-0091	
A6Q3	1855-0091	3		TRANSISTOR J-FET N-CHAN D-MODE SI	28480	1855-0091	
A6Q4	1855-0091	3		TRANSISTOR J-FET N-CHAN D-MODE SI	28480	1855-0091	
A6Q5	1855-0091	3		TRANSISTOR J-FET N-CHAN D-MODE SI	28480	1855-0091	
A6Q6	1854-0215	1	1	TRANSISTOR NPN SI PD#350MW FT#300MHZ	04713	2N3904	
A6Q7	1854-0215	1		TRANSISTOR NPN SI PD#350MW FT#300MHZ	04713	2N3904	
A6Q8	1854-0215	1		TRANSISTOR NPN SI PD#350MW FT#300MHZ	04713	2N3904	
A6Q9	1854-0215	1		TRANSISTOR NPN SI PD#350MW FT#300MHZ	04713	2N3904	
A6Q10	1854-0129	6		TRANSISTOR NPN SI	28480	1854-0129	
A6Q11	1854-0129	6	1	TRANSISTOR NPN SI	28480	1854-0129	
A6Q12	1854-0129	6		TRANSISTOR NPN SI	28480	1854-0129	
A6Q13	1854-0129	6		TRANSISTOR NPN SI	28480	1854-0129	
A6Q14	1855-0091	3		TRANSISTOR J-FET N-CHAN D-MODE SI	28480	1855-0091	
A6Q15	1855-0091	3		TRANSISTOR J-FET N-CHAN D-MODE SI	28480	1855-0091	
A6Q16	1855-0091	3	3	TRANSISTOR J-FET N-CHAN D-MODE SI	28480	1855-0091	
A6Q17	1855-0091	3		TRANSISTOR J-FET N-CHAN D-MODE SI	28480	1855-0091	
A6Q18	1854-0215	1		TRANSISTOR NPN SI PD#350MW FT#300MHZ	04713	2N3904	
A6Q19	1854-0215	1		TRANSISTOR NPN SI PD#350MW FT#300MHZ	04713	2N3904	
A6Q20	1854-0389	0		1	TRANSISTOR NPN 2N4922 SI PD#30W FT#3MMHZ	04713	2N4922
A6Q21	1854-0129	6	6	TRANSISTOR NPN SI	28480	1854-0129	
A6Q22	1854-0129	6		TRANSISTOR NPN SI	28480	1854-0129	
A6Q23	1854-0129	6		TRANSISTOR NPN SI	28480	1854-0129	
A6Q24	1854-0129	6		TRANSISTOR NPN SI	28480	1854-0129	
A6Q25	1854-0129	6		TRANSISTOR NPN SI	28480	1854-0129	
A6Q26	1854-0129	6	9	TRANSISTOR NPN SI	28480	1854-0129	
A6R1	0757-0442	0		1	RESISTOR 10K 1% .125W F TC#0+/-100	24546	C4-1/8-T0=1002-F
A6R2	0757-0419	9			RESISTOR 681 1% .125W F TC#0+/-100	24546	C4-1/8-T0=681R-F
A6R3	2100-3351	6			RESISTOR-TMR 500 10% C SIDE-ADJ 1-TRN	28480	2100-3351
A6R4	0683-3325	6			RESISTOR 3.3K 5% .25W FC TC#-400/+700	01121	CB3325
A6R5	0683-4745	6	5		RESISTOR 470K 5% .25W FC TC#-800/+900	01121	CB4745
A6R6	0683-4745	6	6	RESISTOR 470K 5% .25W FC TC#-800/+900	01121	CB4745	
A6R7	0757-0465	6		RESISTOR 100K 1% .125W F TC#0+/-100	24546	C4-1/8-T0=1003-F	
A6R8	0757-0465	6		RESISTOR 100K 1% .125W F TC#0+/-100	24546	C4-1/8-T0=1003-F	
A6R9	0683-6815	5		2	RESISTOR 680 5% .25W FC TC#-400/+600	01121	CB6815
A6R10	0683-6815	5		RESISTOR 680 5% .25W FC TC#-400/+600	01121	CB6815	
A6R11	0683-2235	5	6	RESISTOR 22K 5% .25W FC TC#-400/+800	01121	CB2235	
A6R12	0683-3325	6		RESISTOR 3.3K 5% .25W FC TC#-400/+700	01121	CB3325	
A6R13	0683-1045	3		RESISTOR 100K 5% .25W FC TC#-400/+800	01121	CB1045	
A6R14	0683-1045	3		RESISTOR 100K 5% .25W FC TC#-400/+800	01121	CB1045	
A6R15	0757-0442	9		RESISTOR 10K 1% .125W F TC#0+/-100	24546	C4-1/8-T0=1002-F	
A6R16	0757-0442	9	4	RESISTOR 10K 1% .125W F TC#0+/-100	24546	C4-1/8-T0=1002-F	
A6R17	0757-0281	4		RESISTOR 2.74K 1% .125W F TC#0+/-100	24546	C4-1/8-T0=2741-F	
A6R18	0757-0442	9		RESISTOR 10K 1% .125W F TC#0+/-100	24546	C4-1/8-T0=1002-F	
A6R19	0757-0442	9		RESISTOR 10K 1% .125W F TC#0+/-100	24546	C4-1/8-T0=1002-F	
A6R20	0757-0281	4		RESISTOR 2.74K 1% .125W F TC#0+/-100	24546	C4-1/8-T0=2741-F	
A6R21	0683-1045	3	6	RESISTOR 100K 5% .25W FC TC#-400/+800	01121	CB1045	
A6R22	0683-1045	3		RESISTOR 100K 5% .25W FC TC#-400/+800	01121	CB1045	
A6R23	0683-3325	6		RESISTOR 3.3K 5% .25W FC TC#-400/+700	01121	CB3325	
A6R24	0683-0715	0		RESISTOR 470 5% .25W FC TC#-400/+600	01121	CB4715	
A6R25	0683-1825	7		RESISTOR 1.8K 5% .25W FC TC#-400/+700	01121	CB1825	
A6R26	0683-4715	0	7	RESISTOR 470 5% .25W FC TC#-400/+600	01121	CB4715	
A6R27	0683-1825	7		RESISTOR 1.8K 5% .25W FC TC#-400/+700	01121	CB1825	
A6R28	0683-4715	0		RESISTOR 470 5% .25W FC TC#-400/+600	01121	CB4715	
A6R29	0683-1825	7		RESISTOR 1.8K 5% .25W FC TC#-400/+700	01121	CB1825	
A6R30	0683-4715	0		RESISTOR 470 5% .25W FC TC#-400/+600	01121	CB4715	
A6R31	0683-3325	6	6	RESISTOR 3.3K 5% .25W FC TC#-400/+700	01121	CB3325	
A6R32	0683-3325	6		RESISTOR 3.3K 5% .25W FC TC#-400/+700	01121	CB3325	
A6R33	0757-0199	3		RESISTOR 21.5K 1% .125W F TC#0+/-100	24546	C4-1/8-T0=2152-F	
A6R34	0683-3325	6		RESISTOR 3.3K 5% .25W FC TC#-400/+700	01121	CB3325	
A6R35	0698-5001	0		1	RESISTOR 15.2K 1% .125W F TC#0+/-100	24546	C4-1/8-T0=1522-F
A6R36	0683-3325	6	6	RESISTOR 3.3K 5% .25W FC TC#-400/+700	01121	CB3325	
A6R37	0757-0199	3		RESISTOR 21.5K 1% .125W F TC#0+/-100	24546	C4-1/8-T0=2152-F	
A6R38	0683-2235	5		RESISTOR 22K 5% .25W FC TC#-400/+800	01121	CB2235	
A6R39	0698-3455	4		1	RESISTOR 261K 1% .125W F TC#0+/-100	24546	C4-1/8-T0=2613-F
A6R40	0683-4745	6		RESISTOR 470K 5% .25W FC TC#-800/+900	01121	CB4745	
A6R41	0683-4735	4	4	RESISTOR 47K 5% .25W FC TC#-400/+800	01121	CB4735	
A6R42	0683-2235	5		RESISTOR 22K 5% .25W FC TC#-400/+800	01121	CB2235	
A6R43	0757-0465	6		RESISTOR 100K 1% .125W F TC#0+/-100	24546	C4-1/8-T0=1003-F	
A6R44	0757-0465	6		RESISTOR 100K 1% .125W F TC#0+/-100	24546	C4-1/8-T0=1003-F	
A6R45	0683-4735	4		RESISTOR 47K 5% .25W FC TC#-400/+800	01121	CB4735	

See introduction to this section for ordering information  
\*Indicates factory selected value

Table 6-3. Replaceable Parts (Cont'd).

Reference Designation	HP Part Number	C D	Qty	Description	Mfr Code	Mfr Part Number
A6R46	06R3-2235	5	4	RESISTOR 22K 5% .25W FC TC=-400/+800	01121	CB2235
A6R47	06R3-1205	7		RESISTOR 12 5% .25W FC TC=-400/+500	01121	CB1205
A6R48	06R3-1205	7		RESISTOR 12 5% .25W FC TC=-400/+500	01121	CB1205
A6R49	06R3-4725	2		RESISTOR 4.7K 5% .25W FC TC=-400/+700	01121	CB4725
A6R50	06R3-2225	3		RESISTOR 2.2K 5% .25W FC TC=-400/+700	01121	CB2225
A6R53	06R3-2715	6	3	RESISTOR 270 5% .25W FC TC=-400/+600	01121	CB2715
A6R54	06R3-1025	9		RESISTOR 1K 5% .25W FC TC=-400/+600	01121	CB1025
A6R55	06R3-1045	3		RESISTOR 100K 5% .25W FC TC=-400/+800	01121	CB1045
A6R56	06R3-1045	3		RESISTOR 100K 5% .25W FC TC=-400/+800	01121	CB1045
A6R57	1R10-0206	8		NETWORK-RES 8-PIN-SIP .1-PIN-SPCG	01121	208A103
A6R58	1R10-0206	8	NETWORK-RES 8-PIN-SIP .1-PIN-SPCG	01121	208A103	
A6R59	06R3-2235	5	RESISTOR 22K 5% .25W FC TC=-400/+800	01121	CB2235	
A6R60	06R3-2235	5	RESISTOR 22K 5% .25W FC TC=-400/+800	01121	CB2235	
A6R61	0757-0442	9	RESISTOR 10K 1% .125W F TC=0+100	24546	C4-1/8-T0=1002-F	
A6R62	0757-0442	9	RESISTOR 10K 1% .125W F TC=0+100	24546	C4-1/8-T0=1002-F	
A6R63	0757-02R1	4	RESISTOR 2.74K 1% .125W F TC=0+100	24546	C4-1/8-T0=2741-F	
A6R64	0757-0442	9	RESISTOR 10K 1% .125W F TC=0+100	24546	C4-1/8-T0=1002-F	
A6R65	0757-0442	9	RESISTOR 10K 1% .125W F TC=0+100	24546	C4-1/8-T0=1002-F	
A6R66	0757-02R1	4	RESISTOR 2.74K 1% .125W F TC=0+100	24546	C4-1/8-T0=2741-F	
A6R67	06R3-2235	5	RESISTOR 22K 5% .25W FC TC=-400/+800	01121	CB2235	
A6R68	06R3-2235	5	RESISTOR 22K 5% .25W FC TC=-400/+800	01121	CB2235	
A6R69	0757-0199	5	RESISTOR 21.5K 1% .125W F TC=0+100	24546	C4-1/8-T0=2152-F	
A6R70	0757-0442	9	RESISTOR 10K 1% .125W F TC=0+100	24546	C4-1/8-T0=1002-F	
A6R71	06R3-1825	7	RESISTOR 1.8K 5% .25W FC TC=-400/+700	01121	CB1825	
A6R72	06R3-1535	6	RESISTOR 15K 5% .25W FC TC=-400/+800	01121	CB1535	
A6R73	1R10-0205	7	NETWORK-RES 8-PIN-SIP .1-PIN-SPCG	01121	208A472	
A6R74	1R10-0205	7	NETWORK-RES 8-PIN-SIP .1-PIN-SPCG	01121	208A472	
A6S1	3101-1273	0	1	SWITCH, SLIDE DPDT-N3	28480	3101-1273
A6T1	9100-0823	6	1	TRANSFORMER, PULSE	28480	9100-0823
A6U1	1R26-0319	7	7	OP AMP BIFET T0-99	27014	LF356H
A6U2	1R26-0319	7		OP AMP BIFET T0-99	27014	LF356H
A6U3	1R26-0319	7		OP AMP BIFET T0-99	27014	LF356H
A6U4	1R26-0081	7		IC-LINEAR BIPOLAR OP-AMP WIDEBAND	27014	
A6U5	1R26-0319	7		OP AMP BIFET T0-99	27014	LF356H
A6U6	1R26-0174	2	3	COMPARATOR GP QUAD 14-DIP-P	28480	1R26-0174
A6U7	1R20-1197	9		IC GATE TTL LS NAND QUAD 2-INP	01295	SN74LS00N
A6U8	1R20-1199	1		IC INV TTL LS HEX 1-INP	01295	SN74LS04N
A6U9	1R20-1112	8		IC FF TTL LS D-TYPE POS-EDGE-TRIG	01295	SN74LS74N
A6U10	1R20-1430	3		IC CNTR TTL LS BIN SYNCHRO POS-EDGE-TRIG	01295	SN74LS161AN
A6U11	1R20-1144	6	5	IC GATE TTL LS NOR QUAD 2-INP	01295	SN74LS02N
A6U12	1R20-1730	6		IC FF TTL LS D-TYPE POS-EDGE-TRIG COM	01295	SN74LS273N
A6U13	1R20-1430	3		IC CNTR TTL LS BIN SYNCHRO POS-EDGE-TRIG	01295	SN74LS161AN
A6U14	1R20-1430	3		IC CNTR TTL LS BIN SYNCHRO POS-EDGE-TRIG	01295	SN74LS161AN
A6U15	1R20-1144	6		IC GATE TTL LS NOR QUAD 2-INP	01295	SN74LS02N
A6U16	1R20-1730	6	IC FF TTL LS D-TYPE POS-EDGE-TRIG COM	01295	SN74LS273N	
A6U17	1R20-1430	3	IC CNTR TTL LS BIN SYNCHRO POS-EDGE-TRIG	01295	SN74LS161AN	
A6U18	1R20-1430	3	IC CNTR TTL LS BIN SYNCHRO POS-EDGE-TRIG	01295	SN74LS161AN	
A6U19	1R20-1112	8	IC FF TTL LS D-TYPE POS-EDGE-TRIG	01295	SN74LS74N	
A6U20	1R26-0122	0	3	IC 7805 V RGLTR T0-220	07263	7805UC
A6W1	8159-0005	0	WIRE 22AWG W PVC 1X22 50C	28480	8159-0005	
A6Y1	0410-0212	7	1	CRYSTAL, QUARTZ 9.60MHZ	28480	0410-0212
A6 MISCELLANEOUS PARTS						
A6Z2	0360-1244	0	1	TERMINAL, SPECIAL FEED-THRU	28480	0360-1244
	04274-26506	9	1	PC BOARD, BLANK	28480	04274-26506
A7	04274-66507	4	1	PERIPHERAL CONTROL BOARD ASSEMBLY	28480	04274-66507
A7	04274-66537	0	1	PERIPHERAL CONTROL BOARD ASSEMBLY (FOR OPTION 004 ONLY)	28480	04274-66537
A7C1	0160-2055	9	9	CAPACITOR-FXD .01UF +80-20% 100VDC CER	28480	0160-2055
A7C2	0150-0121	5		CAPACITOR-FXD .1UF +80-20% 50VDC CER	28480	0150-0121
A7C3	0160-2055	9		CAPACITOR-FXD .01UF +80-20% 100VDC CER	28480	0160-2055
A7C4	0160-2055	9		CAPACITOR-FXD .01UF +80-20% 100VDC CER	28480	0160-2055
A7C5	0160-2055	9		CAPACITOR-FXD .01UF +80-20% 100VDC CER	28480	0160-2055
A7C6	0160-2055	9	9	CAPACITOR-FXD .01UF +80-20% 100VDC CER	28480	0160-2055
A7C7	0160-2055	9		CAPACITOR-FXD .01UF +80-20% 100VDC CER	28480	0160-2055
A7C8	0160-2055	9		CAPACITOR-FXD .01UF +80-20% 100VDC CER	28480	0160-2055
A7C9	0160-2055	9		CAPACITOR-FXD .01UF +80-20% 100VDC CER	28480	0160-2055
A7C10	0160-2055	9		CAPACITOR-FXD .01UF +80-20% 100VDC CER	28480	0160-2055
A7C11	0160-2055	9	9	CAPACITOR-FXD .01UF +80-20% 100VDC CER	28480	0160-2055
A7C12	0150-0121	5		CAPACITOR-FXD .1UF +80-20% 50VDC CER	28480	0150-0121
A7C13	0160-2055	9		CAPACITOR-FXD .01UF +80-20% 100VDC CER	28480	0160-2055
A7C14	01R0-0197	8		CAPACITOR-FXD 2.2UF+/-10% 20VDC TA	56289	150D225X9020A2
A7C15	01R0-0197	8		CAPACITOR-FXD 2.2UF+/-10% 20VDC TA	56289	150D225X9020A2

See introduction to this section for ordering information  
\*Indicates factory selected value

Table 6-3. Replaceable Parts (Cont'd).

Reference Designation	HP Part Number	C D	Qty	Description	Mfr Code	Mfr Part Number
A7C16	0160-2055	9		CAPACITOR-FXD .01UF +80-20% 100VDC CER	28480	0160-2055
A7C17	0180-0197	8		CAPACITOR-FXD 2.2UF+-10% 20VDC TA	56289	1500225X9020A2
A7C18	0180-0228	6		CAPACITOR-FXD 22UF+-10% 15VDC TA	56289	1500226X9019B2
A7C19	0150-0121	5		CAPACITOR-FXD .1UF +80-20% 50VDC CER	28480	0150-0121
A7C20	0160-2247					
A7CR1	1902-0041	4		DIODE-ZNR 5.11V 5% DO-7 PD=.4W TC=-.009%	28480	1902-0041
A7J2	1200-0654	1	5	SOCKET-IC 40-CONT	28480	
A7J3	1200-0613	8	1	SOCKET-IC 28-CONT DIP-SLDR	28480	1200-0613
A7L1	9100-1788	6	6	CHOKE-WIDE BAND ZMAX=680 OHM@ 180 MHZ	02114	VK200 20/48
A7L2	9100-1788	6	6	CHOKE-WIDE BAND ZMAX=680 OHM@ 180 MHZ	02114	VK200 20/48
A7L3	9100-1788	6	6	CHOKE-WIDE BAND ZMAX=680 OHM@ 180 MHZ	02114	VK200 20/48
A7L4	9100-3139	5		COIL 75UH 15% .5DX,875LG=NOM	28480	9100-3139
A7R1	1810-0269	3	15	NETWORK-RES 9-PIN-SIP .1-PIN-SPCG	28480	1810-0269
A7R2	0683-1235	3	13	RESISTOR 12K 5% .25W FC TC=-400/+800	01121	CB1235
A7R3	0683-6825	7	1	RESISTOR 6.8K 5% .25W FC TC=-400/+700	01121	CB6825
A7R4	1810-0269	3		NETWORK-RES 9-PIN-SIP .1-PIN-SPCG	28480	1810-0269
A7R5	1810-0269	3		NETWORK-RES 9-PIN-SIP .1-PIN-SPCG	28480	1810-0269
A7R6	1810-0269	3		NETWORK-RES 9-PIN-SIP .1-PIN-SPCG	28480	1810-0269
A7R7	1810-0269	3		NETWORK-RES 9-PIN-SIP .1-PIN-SPCG	28480	1810-0269
A7R8	1810-0269	3		NETWORK-RES 9-PIN-SIP .1-PIN-SPCG	28480	1810-0269
A7R9	0683-5615	1	6	RESISTOR 560 5% .25W FC TC=-400/+600	01121	CB5615
A7R10	0683-2215	1	2	RESISTOR 220 5% .25W FC TC=-400/+600	01121	CB2215
A7R11	0683-1825	7		RESISTOR 1.8K 5% .25W FC TC=-400/+700	01121	CB1825
A7R12	0683-2215	1		RESISTOR 220 5% .25W FC TC=-400/+600	01121	CB2215
A7T1	9100-0822	7	2	TRANSFORMER, PULSE	28480	9100-0822
A7T2	9100-0822	7		TRANSFORMER, PULSE	28480	9100-0822
A7U1	1820-0909	9	1	IC MULT TTL	01295	SN74167N
A7U2	1820-1112	8		IC FF TTL LS D-TYPE POS-EDGE-TRIG	01295	SN74LS74N
A7U3	1820-1199	1		IC INV TTL LS HEX 1-INP	01295	SN74LS04N
A7U4	1820-1112	8		IC FF TTL LS D-TYPE POS-EDGE-TRIG	01295	SN74LS74N
A7U5	1820-1199	9		IC GATE TTL LS NAND QUAD 2-INP	01295	SN74LS00N
A7U6	1820-1112	8		IC FF TTL LS D-TYPE POS-EDGE-TRIG	01295	SN74LS74N
A7U7	1820-1201	6	1	IC GATE TTL LS AND QUAD 2-INP	01295	SN74LS08N
A7U8	1820-1112	8		IC FF TTL LS D-TYPE POS-EDGE-TRIG	01295	SN74LS74N
A7U9	1820-1211	8	1	IC GATE TTL LS EXCL-OR QUAD 2-INP	01295	SN74LS86N
A7U10	1820-1199	1		IC INV TTL LS HEX 1-INP	01295	SN74LS04N
A7U11	1820-1730	6		IC FF TTL LS D-TYPE POS-EDGE-TRIG COM	01295	SN74LS273N
A7U12	1820-1430	3		IC CNTR TTL LS BIN SYNCHRO POS-EDGE-TRIG	01295	SN74LS161AN
A7U13	1820-1197	9		IC GATE TTL LS NAND QUAD 2-INP	01295	SN74LS00N
A7U15	1820-0054	9		IC-DIGITAL TTL QUAD 2-INP NAND GATE	01295	
A7U16	1820-1828	3	4	IC DRVR TTL BUS DRVR QUAD	18324	N8T28N
A7U17	1820-1481	4	3	IC PIA NMOS	04713	MC6821L
A7U18	1820-1828	3		IC DRVR TTL BUS DRVR QUAD	18324	N8T28N
A7U19	1820-1470	1	2	IC MUXR/DATA-SEL TTL LS 2-TO-1-LINE QUAD	01295	SN74LS157N
A7U20	1820-1112	8		IC FF TTL LS D-TYPE POS-EDGE-TRIG	01295	SN74LS74N
A7U21	1820-1206	1	1	IC GATE TTL LS NOR TPL 3-INP	01295	SN74LS27N
A7U22	1820-1430	3		IC CNTR TTL LS BIN SYNCHRO POS-EDGE-TRIG	01295	SN74LS161AN
A7U23	1820-1430	3		IC CNTR TTL LS BIN SYNCHRO POS-EDGE-TRIG	01295	SN74LS161AN
A7U24	1820-1144	6		IC GATE TTL LS NOR QUAD 2-INP	01295	SN74LS02N
A7U25	1820-2255	6	1	IC CNTR C-MOS	28480	U20-131
A7U26	1820-1210	7		IC GATE TTL LS AND-OR-INV DUAL 2-INP	01295	SN74LS51N
A7U27	1820-1828	3		IC DRVR TTL BUS DRVR QUAD	18324	N8T28N
A7U28	1820-1828	3		IC DRVR TTL BUS DRVR QUAD	18324	N8T28N
A7U29	1820-1470	1		IC MUXR/DATA-SEL TTL LS 2-TO-1-LINE QUAD	01295	SN74LS157N
A7U30	1820-1216	3	4	IC OCDR TTL LS 3-TO-8-LINE 3-INP	01295	SN74LS138N
A7U31	1820-0495	8	3	IC OCDR TTL 4-TO-16-LINE 4-INP	01295	SN74LS4N
A7U32	1820-1430	3		IC CNTR TTL LS BIN SYNCHRO POS-EDGE-TRIG	01295	SN74LS161AN
A7U33	1820-1430	3		IC CNTR TTL LS BIN SYNCHRO POS-EDGE-TRIG	01295	SN74LS161AN
A7W4	8159-0005	0		WIRE 22AWG W PVC 1X22 80C	28480	8159-0005
A7W5	8159-0005	0		WIRE 22AWG W PVC 1X22 80C	28480	8159-0005
A7W6	8159-0005	0		WIRE 22AWG W PVC 1X22 80C	28480	8159-0005
A7W7	8159-0005	0		WIRE 22AWG W PVC 1X22 80C	28480	8159-0005
A7W9	8159-0005	0		WIRE 22AWG W PVC 1X22 80C	28480	8159-0005
A7Y1	0410-0211	6	1	CRYSTAL, QUARTZ 9.95 MHZ	28480	0410-0211
				A7 MISCELLANEOUS PARTS		
	04274-26507	0		PC BOARD, BLANK	28480	04274-26507
A9	04274-66508	5	1	DISPLAY AND KEY CONTROL BOARD ASSEMBLY	28480	04274-66508
A8C1	0160-2055	9		CAPACITOR-FXD .01UF +80-20% 100VDC CER	28480	0160-2055
A8C2	0160-2055	9		CAPACITOR-FXD .01UF +80-20% 100VDC CER	28480	0160-2055
A8C3	0160-2055	9		CAPACITOR-FXD .01UF +80-20% 100VDC CER	28480	0160-2055
A8C4	0160-2055	9		CAPACITOR-FXD .01UF +80-20% 100VDC CER	28480	0160-2055
A8C5	0160-2055	9		CAPACITOR-FXD .01UF +80-20% 100VDC CER	28480	0160-2055

See introduction to this section for ordering information  
\*Indicates factory selected value

Table 6-3. Replaceable Parts (Cont'd).

Reference Designation	HP Part Number	C D	Qty	Description	Mfr Code	Mfr Part Number
A8C6	0160-2055	9		CAPACITOR-FXD .01UF +80-20% 100VDC CER	28480	0160-2055
A8C7	0160-2055	9		CAPACITOR-FXD .01UF +80-20% 100VDC CER	28480	0160-2055
A8C8	0160-2055	9		CAPACITOR-FXD .01UF +80-20% 100VDC CER	28480	0160-2055
A8C9	0160-2055	9		CAPACITOR-FXD .01UF +80-20% 100VDC CER	28480	0160-2055
A8C10	0160-0155	8		CAPACITOR-FXD 3.3NF +-10% 200VDC POLYE	56289	
A8C11	0160-0155	8		CAPACITOR-FXD 3.3NF +-10% 200VDC POLYE	56289	
A8C12	0160-0155	8		CAPACITPR-FXD 3.3NF +-10% 200VDC POLYE	56289	
A8C13	0180-1050	4		CAPACITOR, FXD 100 UF 25VDCW	28480	0180-1050
A8C14	0180-0228	9		CAPACITOR-FXD 22UF+-10% 15VDC TA	56289	1500226X9015B2
A8C15	0160-2055	9		CAPACITOR-FXD .01UF +80-20% 100VDC CER	28480	0160-2055
A8C16	0160-2055	9		CAPACITOR-FXD .01UF +80-20% 100VDC CER	28480	0160-2055
A8C17	0160-2055	9		CAPACITOR-FXD .01UF +80-20% 100VDC CER	28480	0160-2055
A8C18	0160-2055	9		CAPACITOR-FXD .01UF +80-20% 100VDC CER	28480	0160-2055
A8C19	0160-2055	9		CAPACITOR-FXD .01UF +80-20% 100VDC CER	28480	0160-2055
A8C20	0160-2055	9		CAPACITOR-FXD .01UF +80-20% 100VDC CER	28480	0160-2055
A8C21	0160-2055	9		CAPACITOR-FXD .01UF +80-20% 100VDC CER	28480	0160-2055
A8C22	0160-2055	9		CAPACITOR-FXD .01UF +80-20% 100VDC CER	28480	0160-2055
A8C23	0150-0121	5		CAPACITOR-FXD .1UF +80-20% 50VDC CER	28480	0150-0121
A8C24	0180-0228	6		CAPACITOR-FXD 22UF+-10% 15VDC TA	56289	1500226X9015B2
A8L1	9100-3139	5		COIL 75UH 15% .50X.875LG-NOM	28480	9100-3139
A8L2	9100-3139	5		COIL 75UH 15% .50X.875LG-NOM	28480	9100-3139
A8L3	9100-1788	6		CHOKER-WIDE BAND 2MAX=680 OHM@ 180 MHZ	02114	VK200 20748
A8Q1	1854-0019	3	1	TRANSISTOR NPN SI TO-18 PD=360MW	28480	1854-0019
A8R1	1810-0205	7		NETWORK-RES 8-PIN-SIP .1-PIN-SPCG	01121	208A472
A8R2	1810-0205	7		NETWORK-RES 8-PIN-SIP .1-PIN-SPCG	01121	208A472
A8R3	1810-0205	7		NETWORK-RES 8-PIN-SIP .1-PIN-SPCG	01121	208A472
A8R6	1810-0301	4	3	NETWORK-RES 16-PIN-DIP .1-PIN-SPCG	01121	3168510
A8R7	1810-0301	4		NETWORK-RES 16-PIN-DIP .1-PIN-SPCG	01121	3168510
A8R8	1810-0301	4		NETWORK-RES 16-PIN-DIP .1-PIN-SPCG	01121	3168510
A8R9	1810-0205	7		NETWORK-RES 8-PIN-SIP .1-PIN-SPCG	01121	208A472
A8R10	0683-1205	2		RESISTOR 12 5% .25W FC TC=400/+600	01121	
A8R11	0683-1205	2		RESISTOR 12 5% .25W FC TC=400/+600	01121	
A8R12	0683-1205	2		RESISTOR 12 5% .25W FC TC=400/+600	01121	
A8S1	3101-2061	6	1	SWITCH, TOGGLE DIP-ROCKER	28480	3101-2061
A8U1	1858-0023	7	3	TRANSISTOR ARRAY	01928	CA3081E
A8U2	1858-0023	7		TRANSISTOR ARRAY	01928	CA3081E
A8U3	1858-0023	7		TRANSISTOR ARRAY	01928	CA3081E
A8U4	1820-0628	9	6	IC TTL 64-BIT RAM 60-NS 0-C	01295	8N7489N
A8U5	1820-0628	9		IC TTL 64-BIT RAM 60-NS 0-C	01295	8N7489N
A8U6	1820-0628	9		IC TTL 64-BIT RAM 60-NS 0-C	01295	8N7489N
A8U7	1820-1194	6	1	IC CNTR TTL LS BIN UP/DOWN SYNCHRO	01295	8N74L8193N
A8U8	1820-1278	7	2	IC CNTR TTL LS BIN UP/DOWN SYNCHRO	01295	8N74L8191N
A8U9	1820-1112	8		IC FF TTL LS D-TYPE POS-EDGE-TRIG	01295	8N74L874N
A8U10	1820-0628	9		IC TTL 64-BIT RAM 60-NS 0-C	01295	8N7489N
A8U11	1820-0628	9		IC TTL 64-BIT RAM 60-NS 0-C	01295	8N7489N
A8U12	1820-0628	9		IC TTL 64-BIT RAM 60-NS 0-C	01295	8N7489N
A8U13	1820-1199	1		IC INV TTL LS HEX 1-INP	01295	8N74L804N
A8U14	1820-1415	4	1	IC SCHMITT-TRIG TTL LS NAND DUAL 4-INP	01295	8N74L813N
A8U15	1820-1278	7		IC CNTR TTL LS BIN UP/DOWN SYNCHRO	01295	8N74L8191N
A8U16	1820-1202	7	1	IC GATE TTL LS NAND TPL 3-INP	01295	8N74L810N
A8 MISCELLANEOUS PARTS						
A8Z1	04274-26508	1		PC BOARD, BLANK	28480	04274-26508
A9	04274-66509			PC BOARD ASSEMBLY (STANDARD)		
A9	04274-66514	3		MPU BOARD ASSEMBLY (FOR OPTION 003 ONLY)		04274-66514
A9	04274-66517	6		MPU BOARD ASSEMBLY (FOR OPT. 101 ONLY) (BTI)	28480	04274-66517
A9	04274-66518	7	1	MPU BOARD ASSEMBLY (FOR OPT. 003 PLUS 101 ONLY)	28480	04274-66518
A9BT1	1420-0125			BATTERY LITHIUM 2.8V		
A9C1	0160-2055	9		CAPACITOR-FXD .01UF +80-20% 100VDC CER	28480	0160-2055
A9C2	0160-2055	9		CAPACITOR-FXD .01UF +80-20% 100VDC CER	28480	0160-2055
A9C3	0160-2055	9		CAPACITOR-FXD .01UF +80-20% 100VDC CER	28480	0160-2055
A9C4	0160-2055	9		CAPACITOR-FXD .01UF +80-20% 100VDC CER	28480	0160-2055
A9C5	0160-2055	9		CAPACITOR-FXD .01UF +80-20% 100VDC CER	28480	0160-2055
A9C6	0160-2055	9		CAPACITOR-FXD .01UF +80-20% 100VDC CER	28480	0160-2055
A9C7	0160-0134	1		CAPACITOR-FXD 220PF +-5% 300VDC MICA	28480	0160-0134
A9C8	0160-2055	9		CAPACITOR-FXD .01UF +80-20% 100VDC CER	28480	0160-2055
A9C9	0150-0121	5		CAPACITOR-FXD .1UF +80-20% 50VDC CER	28480	0150-0121
A9C10	0160-2307	4	2	CAPACITOR-FXD 47PF +-5% 300VDC MICA	28480	0160-2307

See introduction to this section for ordering information  
\*Indicates factory selected value

Table 6-3. Replaceable Parts (Cont'd).

Reference Designation	HP Part Number	C D	Qty	Description	Mfr Code	Mfr Part Number	
A9C11	0160-2307	4	1	CAPACITOR-FXD 47PF +-5% 300VDC MICA	28480	0160-2307	
A9C12	0180-0229	7		CAPACITOR-FXD 33UF+-10% 10VDC TA	56289	150D336X9010H2	
A9C13	0180-0291	3		CAPACITOR-FXD 1UF+-10% 35VDC TA	56289	150D105X9035A2	
A9C14	0160-2055	9		CAPACITOR-FXD .01UF +80-20% 100VDC CER	28480	0160-2055	
A9C15	0160-2055	9		CAPACITOR-FXD .01UF +80-20% 100VDC CER	28480	0160-2055	
A9C16	0160-2055	9		CAPACITOR-FXD .01UF +80-20% 100VDC CER	28480	0160-2055	
A9C17	0160-2055	9		CAPACITOR-FXD .01UF +80-20% 100VDC CER	28480	0160-2055	
A9C18	0160-2055	9		CAPACITOR-FXD .01UF +80-20% 100VDC CER	28480	0160-2055	
A9C19	0160-2055	9		CAPACITOR-FXD .01UF +80-20% 100VDC CER	28480	0160-2055	
A9C20	0160-2055	9		CAPACITOR-FXD .01UF +80-20% 100VDC CER	28480	0160-2055	
A9C21	0150-0121	5		CAPACITOR-FXD .1UF +80-20% 50VDC CER	28480	0150-0121	
A9C22	0180-0197	8		CAPACITOR-FXD 2.2UF+-10% 20VDC TA	56289	150D225X9020A2	
A9C23	0180-0228	6		CAPACITOR-FXD 22UF+-10% 15VDC TA	56289	150D226X9015B2	
A9C24	0160-2055	9		CAPACITOR-FXD .01UF +80-20% 100VDC CER	28480	0160-2055	
A9C25	0180-0197	8		CAPACITOR-FXD 2.2UF+-10% 20VDC TA	56289	150D225X9020A2	
A9C26	0150-0121	5		CAPACITOR-FXD .1UF +80-20% 50VDC CER	28480	0150-0121	
A9C27	0150-0121	5		CAPACITOR-FXD .1UF +80-20% 50VDC CER	28480	0150-0121	
A9C28	0160-2208	4		CAPACITOR-FXD 330PF +-5% 300VDC MICA	28480	0160-2208	
A9CR1	1901-0518	8		DIODE-8SCHOTTKY	28480	1901-0518	
A9CR2	1901-0518	8		DIODE-8SCHOTTKY	28480	1901-0518	
A9CR3	1901-0025	2		DIODE-GEN PRP 100V 200MA DO-7	28480	1901-0025	
A9CR4	1901-0025	2		DIODE-GEN PRP 100V 200MA DO-7	28480	1901-0025	
A9CR5	1901-0040	1		DIODE-SWITCHING 30V 50MA 2NS DO-35	28480	1901-0040	
A9J12	1200-0654	1		SOCKET-IC 40-CONT	28480		
A9L1	9100-1788	6		CHOKE-WIDE BAND ZMAX=680 OHM@ 180 MHZ	02114	VK200 20/48	
A9L2	9100-3139	5		COIL 75UH 15% .5DX,875LG-NOM	28480	9100-3139	
A9Q1	1853-0015	7	2	TRANSISTOR PNP SI PD=200MH FT=500MHZ	28480	1853-0015	
A9Q2	1853-0015	7		TRANSISTOR PNP SI PD=200MH FT=500MHZ	28480	1853-0015	
A9R1	1810-0305	8	3	NETWORK-RES 9-PIN-SIP .1-PIN-SPCG	28480	1810-0305	
A9R2	1810-0305	8		NETWORK-RES 9-PIN-SIP .1-PIN-SPCG	28480	1810-0305	
A9R3	1810-0305	8		NETWORK-RES 9-PIN-SIP .1-PIN-SPCG	28480	1810-0305	
A9R4	0683-1035	1		RESISTOR 10K 5% .25W FC TC=-400/+700	01121	C81035	
A9R5	0683-2205	9		RESISTOR 22 5% .25W FC TC=-400/+500	01121	C82205	
A9R6	0683-1205	7		RESISTOR 12 5% .25W FC TC=-400/+500	01121	C81205	
A9R7	0683-2205	9		RESISTOR 22 5% .25W FC TC=-400/+500	01121	C82205	
A9R8	0683-1205	7		RESISTOR 12 5% .25W FC TC=-400/+500	01121	C81205	
A9R9	0683-1515	2		RESISTOR 150 5% .25W FC TC=-400/+600	01121	C81515	
A9R10	0683-1515	2		RESISTOR 150 5% .25W FC TC=-400/+600	01121	C81515	
A9R11	1810-0269	3		NETWORK-RES 9-PIN-SIP .1-PIN-SPCG	28480	1810-0269	
A9R12	0683-2715	6		RESISTOR 270 5% .25W FC TC=-400/+600	01121	C82715	
A9R13	0683-2715	6		RESISTOR 270 5% .25W FC TC=-400/+600	01121	C82715	
A9R14	0683-4715	0		RESISTOR 470 5% .25W FC TC=-400/+600	01121	C84715	
A9R15	0698-4501	3		RESISTOR 59K 1% .125W F TC=0/+100	24546	C4-1/8-T0-5902-F	
A9R17	0683-1035	1		RESISTOR 10K 5% .25W FC TC=-400/+700	01121	C81035	
A9R18	0683-1035	1		RESISTOR 10K 5% .25W FC TC=-400/+700	01121	C81035	
A9R19	0683-4745	6		RESISTOR 470K 5% .25W FC TC=-800/+900	01121	C84745	
A9R20	0683-1025	9		RESISTOR 1K 5% .25W FC TC=-400/+600	01121	C81025	
A9R21	1810-0269	3		NETWORK-RES 9-PIN-SIP .1-PIN-SPCG	28480	1810-0269	
A9R22	0683-4745	6		RESISTOR 470K 5% .25W FC TC=-800/+900	01121	C84745	
A9R23	0683-1015	7		RESISTOR 100 5% .25W FC TC=-400/+500	01121	C81015	
A9R24	0683-1035	1		RESISTOR 10K 5% .25W FC TC=-400/+700	01121	C81035	
A9R25	0683-1035	1		RESISTOR 10K 5% .25W FC TC=-400/+700	01121	C81035	
A991	3101-1973	7	2	SWITCH, SLIDE 7-1A-NS	28480	3101-1973	
A9U1	1818-1134	7	1	IC, MASK-ROM	28480		
A9U3	1818-1135	7	1	IC, MASK-ROM	28480		
A9U5	1818-1136	9	1	IC, MASK-ROM	28480		
A9U7	1818-1137	1	1	IC, MASK-ROM	28480		
A9U10	1818-1139	3	1	IC, MASK-ROM	28480		
A9U12	1818-0438	4		IC NMOS 4K RAM 8TAT 450-NS 3-S	34649	P2114	
A9U13	1818-0438	4	2	IC NMOS 4K RAM 8TAT 450-NS 3-S	34649	P2114	
A9U14	1818-0796	7		IC CMOS 1K RAM 8TAT 350-NS 3-S	28480	1818-0796	
A9U15	1818-0796	7		IC CMOS 1K RAM 8TAT 350-NS 3-S	28480	1818-0796	
A9U16	1820-1216	3		IC DCOR TTL L8 3-TO-8-LINE 3-INP	01295	8N74LS138N	
A9U17	1820-2024	3		IC DRVR TTL L8 LINE DRVR OCTL	01295	8N74LS244N	
A9U18	1820-1480	3		1	IC MICPROC NMOS 8-BIT	04713	MC6800L
A9U19	1820-1144	6			IC GATE TTL L8 NOR QUAD 2-INP	01295	8N74LS02N
A9U20	1820-06A3	6	IC INV TTL 8 HEX 1-INP		01295	8N74804N	
A9U21	1820-1197	9	IC GATE TTL L8 NAND QUAD 2-INP		01295	8N74LS00N	
A9U22	1820-1216	3	IC DCOR TTL L8 3-TO-8-LINE 3-INP		01295	8N74LS138N	

See introduction to this section for ordering information  
\*Indicates factory selected value

Table 6-3. Replaceable Parts (Cont'd).

Reference Designation	HP Part Number	C D	Qty	Description	Mfr Code	Mfr Part Number
A9U23	1820-1491	6	2	IC BFR TTL LS NON-INV HEX 1-INP	01295	8N74LS367AN
A9U25	1826-0408	5	1	8-DIP-P	32293	1CL8212CPA
A9U26	1829-0661	0	1	IC GATE TTL OR QUAD 2-INP	01295	8N7432N
A9U27	1820-1197	9		IC GATE TTL LS NAND QUAD 2-INP	01295	8N74LS00N
A9U28	1820-1216	3		IC ODDR TTL LS 3-TO-8-LINE 3-INP	01295	8N74LS138N
A9U29	1820-2024	3		IC DRVR TTL LS LINE DRVR OCTL	01295	8N74LS244N
A9U30	1906-0075	2	1	DIODE-ARRAY 40V 400MA	28480	1906-0075
A9U31	1820-1994	4	2	IC DRVR TTL LS LINE DRVR OCTL	01295	8N74LS243N
A9U32	1820-1994	4		IC DRVR TTL LS LINE DRVR OCTL	01295	8N74LS243N
A9U33	1820-1491	6		IC BFR TTL LS NON-INV HEX 1-INP	01295	8N74LS367AN
A9U34	1820-1199	1		IC INV TTL LS HEX 1-INP	01295	8N74LS04N
A9U35	1826-0180	0	1	IC TIMER TTL MONO/ASTBL	04713	MC1455P1
A9W1	8159-0005	0		WIRE 22AWG W PVC 1X22 80C	28480	8159-0005
A9W2	8159-0005	0		WIRE 22AWG W PVC 1X22 80C	28480	8159-0005
A9W3	8159-0005	0		WIRE 22AWG W PVC 1X22 80C	28480	8159-0005
A9W4	8159-0005	0		WIRE 22AWG W PVC 1X22 80C	28480	8159-0005
A9W5	8159-0005	0		WIRE 22AWG W PVC 1X22 80C	28480	8159-0005
A9W6	8159-0005	0		WIRE 22AWG W PVC 1X22 80C	28480	8159-0005
A9 MISCELLANEOUS PARTS						
	04274-26509	2		PC BOARD, BLANK	28480	04274-26509
A10	04274-66520	9	1	DISPLAY AND KEYBOARD ASSEMBLY	28480	04274-66520
A10C1	0160-2028	6		CAPACITOR-FXD 22UF+-10% 15VDC TA	56289	150D226X901582
A10C2	0160-2055	9		CAPACITOR-FXD .01UF +80-20% 100VDC CER	28480	0160-2055
A10C3	0160-2055	9		CAPACITOR-FXD .01UF +80-20% 100VDC CER	28480	0160-2055
A10C4	0160-2055	9		CAPACITOR-FXD .01UF +80-20% 100VDC CER	28480	0160-2055
A10C5	0160-2055	9		CAPACITOR-FXD .01UF +80-20% 100VDC CER	28480	0160-2055
A10C6	0160-2055	9		CAPACITOR-FXD .01UF +80-20% 100VDC CER	28480	0160-2055
A10C7	0160-2055	9		CAPACITOR-FXD .01UF +80-20% 100VDC CER	28480	0160-2055
A10C8	0160-2055	9		CAPACITOR-FXD .01UF +80-20% 100VDC CER	28480	0160-2055
A10C9	0160-2055	9		CAPACITOR-FXD .01UF +80-20% 100VDC CER	28480	0160-2055
A10C10	0160-2055	9		CAPACITOR-FXD .01UF +80-20% 100VDC CER	28480	0160-2055
A10C11	0160-2055	9		CAPACITOR-FXD .01UF +80-20% 100VDC CER	28480	0160-2055
A10C12	0160-2055	9		CAPACITOR-FXD .01UF +80-20% 100VDC CER	28480	0160-2055
A10C13	0160-2055	9		CAPACITOR-FXD .01UF +80-20% 100VDC CER	28480	0160-2055
A10DS1	1990-0486	6	35	LED-VISIBLE LUM-INT=1MCD IF=20MA-MAX	28480	5082-4684
A10DS2	1990-0540	3	12	DISPLAY-NUM-SEG 1-CHAR .43-H	28480	5082-7650
A10DS3	1990-0540	3		DISPLAY-NUM-SEG 1-CHAR .43-H	28480	5082-7650
A10DS4	1990-0540	3		DISPLAY-NUM-SEG 1-CHAR .43-H	28480	5082-7650
A10DS5	1990-0540	3		DISPLAY-NUM-SEG 1-CHAR .43-H	28480	5082-7650
A10DS6	1990-0540	3		DISPLAY-NUM-SEG 1-CHAR .43-H	28480	5082-7650
A10DS7	1990-0540	3		DISPLAY-NUM-SEG 1-CHAR .43-H	28480	5082-7650
A10DS8	1990-0617	5	4	DISPLAY=AN=DOT MAT 1-CHAR .3-H	28480	1990-0617
A10DS9	1990-0617	5		DISPLAY=AN=DOT MAT 1-CHAR .3-H	28480	1990-0617
A10DS10	1990-0540	3		DISPLAY-NUM-SEG 1-CHAR .43-H	28480	5082-7650
A10DS11	1990-0540	3		DISPLAY-NUM-SEG 1-CHAR .43-H	28480	5082-7650
A10DS12	1990-0540	3		DISPLAY-NUM-SEG 1-CHAR .43-H	28480	5082-7650
A10DS13	1990-0540	3		DISPLAY-NUM-SEG 1-CHAR .43-H	28480	5082-7650
A10DS14	1990-0540	3		DISPLAY-NUM-SEG 1-CHAR .43-H	28480	5082-7650
A10DS15	1990-0540	3		DISPLAY-NUM-SEG 1-CHAR .43-H	28480	5082-7650
A10DS16	1990-0617	5		DISPLAY=AN=DOT MAT 1-CHAR .3-H	28480	1990-0617
A10DS17	1990-0617	5		DISPLAY=AN=DOT MAT 1-CHAR .3-H	28480	1990-0617
A10DS18	1990-0434	4	3	DISPLAY-NUM-SEG 1-CHAR .3-H	28480	5082-7730, CAT B=E
A10DS19	1990-0434	4		DISPLAY-NUM-SEG 1-CHAR .3-H	28480	5082-7730, CAT B=E
A10DS20	1990-0434	4		DISPLAY-NUM-SEG 1-CHAR .3-H	28480	5082-7730, CAT B=E
A10DS21	1990-0486	6		LED-VISIBLE LUM-INT=1MCD IF=20MA-MAX	28480	5082-4684
A10DS22	1990-0486	6		LED-VISIBLE LUM-INT=1MCD IF=20MA-MAX	28480	5082-4684
A10DS23	1990-0486	6		LED-VISIBLE LUM-INT=1MCD IF=20MA-MAX	28480	5082-4684
A10DS24	1990-0486	6		LED-VISIBLE LUM-INT=1MCD IF=20MA-MAX	28480	5082-4684
A10DS25	1990-0517	4	1	LED-VISIBLE LUM-INT=3MCD IF=20MA-MAX	28480	5082-4655
A10DS26	1990-0665	6		LED-VISIBLE LUM-INT=1MCD IF=20MA-MAX	28480	
A10DS27	1990-0665	6		LED-VISIBLE LUM-INT=1MCD IF=20MA-MAX	28480	
A10DS28	1990-0665	6		LED-VISIBLE LUM-INT=1MCD IF=20MA-MAX	28480	
A10DS29	1990-0665	6		LED-VISIBLE LUM-INT=1MCD IF=20MA-MAX	28480	
A10DS30	1990-0665	6		LED-VISIBLE LUM-INT=1MCD IF=20MA-MAX	28480	
A10DS31	1990-0665	6		LED-VISIBLE LUM-INT=1MCD IF=20MA-MAX	28480	
A10DS32	1990-0665	6		LED-VISIBLE LUM-INT=1MCD IF=20MA-MAX	28480	
A10DS33	1990-0665	6		LED-VISIBLE LUM-INT=1MCD IF=20MA-MAX	28480	
A10DS34	1990-0665	6		LED-VISIBLE LUM-INT=1MCD IF=20MA-MAX	28480	
A10DS35	1990-0486	6		LED-VISIBLE LUM-INT=1MCD IF=20MA-MAX	28480	5082-4684

See introduction to this section for ordering information  
\*Indicates factory selected value

Table 6-3. Replaceable Parts (Cont'd).

Reference Designation	HP Part Number	C D	Qty	Description	Mfr Code	Mfr Part Number
A10S36	1990-0665	6		LED-VISIBLE LUM-INT=1MCD IF=20MA-MAX	28480	
A10S37	1990-0665	6		LED-VISIBLE LUM-INT=1MCD IF=20MA-MAX	28480	
A10S38	1990-0665	6		LED-VISIBLE LUM-INT=1MCD IF=20MA-MAX	28480	
A10S39	1990-0665	6		LED-VISIBLE LUM-INT=1MCD IF=20MA-MAX	28480	
A10S40	1990-0665	6		LED-VISIBLE LUM-INT=1MCD IF=20MA-MAX	28480	
A10S41	1990-0665	6		LED-VISIBLE LUM-INT=1MCD IF=20MA-MAX	28480	
A10S42	1990-0665	6		LED-VISIBLE LUM-INT=1MCD IF=20MA-MAX	28480	
A10S43	1990-0665	6		LED-VISIBLE LUM-INT=1MCD IF=20MA-MAX	28480	
A10S44	1990-0665	6		LED-VISIBLE LUM-INT=1MCD IF=20MA-MAX	28480	
A10S45	1990-0665	6		LED-VISIBLE LUM-INT=1MCD IF=20MA-MAX	28480	
A10S46	1990-0665	6		LED-VISIBLE LUM-INT=1MCD IF=20MA-MAX	28480	
A10S47	1990-0665	6		LED-VISIBLE LUM-INT=1MCD IF=20MA-MAX	28480	
A10S48	1990-0665	6		LED-VISIBLE LUM-INT=1MCD IF=20MA-MAX	28480	
A10S49	1990-0665	6		LED-VISIBLE LUM-INT=1MCD IF=20MA-MAX	28480	
A10S50	1990-0665	6		LED-VISIBLE LUM-INT=1MCD IF=20MA-MAX	28480	
A10S51	1990-0665	6		LED-VISIBLE LUM-INT=1MCD IF=20MA-MAX	28480	
A10S52	1990-0486	6		LED-VISIBLE LUM-INT=1MCD IF=20MA-MAX	28480	5082-4684
A10S53	1990-0486	6		LED-VISIBLE LUM-INT=1MCD IF=20MA-MAX	28480	5082-4684
A10S54	1990-0486	6		LED-VISIBLE LUM-INT=1MCD IF=20MA-MAX	28480	5082-4684
A10S55	1990-0486	6		LED-VISIBLE LUM-INT=1MCD IF=20MA-MAX	28480	5082-4684
A10J2	1200-0638	9	12	SOCKET-IC 14-CONT DIP-SLDR SOCKET FOR DS2 THROUGH DS7	28480	
A10J3	1200-0638	9		SOCKET-IC 14-CONT DIP-SLDR	28480	
A10J4	1200-0638	9		SOCKET-IC 14-CONT DIP-SLDR	28480	
A10J5	1200-0638	9		SOCKET-IC 14-CONT DIP-SLDR	28480	
A10J6	1200-0638	9		SOCKET-IC 14-CONT DIP-SLDR	28480	
A10J7	1200-0638	9		SOCKET-IC 14-CONT DIP-SLDR	28480	
A10J8	1200-0424	9	4	SOCKET-ELEC (MISC ITEM) 14-PIN SOCKET FOR DS8, 9, 16, AND 17	28480	1200-0424
A10J9	1200-0424	9		SOCKET-ELEC (MISC ITEM)	28480	1200-0424
A10J10	1200-0638	9		SOCKET-IC 14-CONT DIP-SLDR	28480	
A10J11	1200-0638	9		SOCKET-IC 14-CONT DIP-SLDR	28480	
A10J12	1200-0638	9		SOCKET-IC 14-CONT DIP-SLDR	28480	
A10J13	1200-0638	9		SOCKET-IC 14-CONT DIP-SLDR	28480	
A10J14	1200-0638	9		SOCKET-IC 14-CONT DIP-SLDR	28480	
A10J15	1200-0638	9		SOCKET-IC 14-CONT DIP-SLDR	28480	
A10J16	1200-0424	9		SOCKET-ELEC (MISC ITEM)	28480	1200-0424
A10J17	1200-0424	9		SOCKET-ELEC (MISC ITEM)	28480	1200-0424
A10J18	1200-0508	0	3	SOCKET-IC 14-CONT DIP-SLDR SOCKET FOR DS18 THROUGH DS20	28480	1200-0508
A10J19	1200-0508	0		SOCKET-IC 14-CONT DIP-SLDR	28480	1200-0508
A10J20	1200-0508	0		SOCKET-IC 14-CONT DIP-SLDR	28480	1200-0508
A10KC1	5041-0252	7	6	KEY CAP	28480	5041-0252
A10KC2	5041-0252	7		KEY CAP	28480	5041-0252
A10KC3	5041-0351	7	3	KEY CAP	28480	5041-0351
A10KC4	5041-0252	7		KEY CAP	28480	5041-0252
A10KC5	5041-0252	7		KEY CAP	28480	5041-0252
A10KC6	5041-0252	7		KEY CAP	28480	5041-0252
A10KC7	5041-0252	7		KEY CAP	28480	5041-0252
A10KC8	5041-0351	7		KEY CAP	28480	5041-0351
A10KC9	5041-0351	7		KEY CAP	28480	5041-0351
A10KC10	5041-0309	5	8	KEY CAP	28480	5041-0309
A10KC11	5041-0309	5		KEY CAP	28480	5041-0309
A10KC12	5041-0318	6	15	*LK CAP- PTY GRAY	28480	5041-0318
A10KC13	5041-0318	6		*LK CAP- PTY GRAY	28480	5041-0318
A10KC14	5041-0309	5		KEY CAP	28480	5041-0309
A10KC15	5041-0309	5		KEY CAP	28480	5041-0309
A10KC16	5041-0318	6		*LK CAP- PTY GRAY	28480	5041-0318
A10KC17	5041-0318	6		*LK CAP- PTY GRAY	28480	5041-0318
A10KC18	5041-0318	6		*LK CAP- PTY GRAY	28480	5041-0318
A10KC19	5041-0318	6		*LK CAP- PTY GRAY	28480	5041-0318
A10KC20	5041-0309	5		KEY CAP	28480	5041-0309
A10KC21	5041-0309	5		KEY CAP	28480	5041-0309
A10KC22	5041-0318	6		*LK CAP- PTY GRAY	28480	5041-0318
A10KC23	5041-0318	6		*LK CAP- PTY GRAY	28480	5041-0318
A10KC24	5041-0318	6		*LK CAP- PTY GRAY	28480	5041-0318
A10KC25	5041-0318	6		*LK CAP- PTY GRAY	28480	5041-0318
A10KC30	5041-0318	6		*LK CAP- PTY GRAY	28480	5041-0318
A10KC31	5041-0318	6		*LK CAP- PTY GRAY	28480	5041-0318
A10KC32	5041-0309	5		KEY CAP	28480	5041-0309
A10KC33	5041-0309	5		KEY CAP	28480	5041-0309
A10KC34	5041-0375	5	1	KEY-Q-SMOKE GRAY	28480	5041-0375
A10KC35	5041-0318	6		*LK CAP- PTY GRAY	28480	5041-0318
A10KC36	5041-0318	6		*LK CAP- PTY GRAY	28480	5041-0318
A10KC37	5041-0318	6		*LK CAP- PTY GRAY	28480	5041-0318
A10KC38	5041-0384	6	1	KEY-Q-SMOKE GRAY	28480	5041-0384

See introduction to this section for ordering information  
\*Indicates factory selected value



Table 6-3. Replaceable Parts (Cont'd).

Reference Designation	HP Part Number	C D	Qty	Description	Mfr Code	Mfr Part Number
A10R1	0757-0400	9	14	RESISTOR 90.9 1% .125W F TC=0+-100	24546	C4-1/8-T0-90R9-F
A10R2	0757-0400	9		RESISTOR 90.9 1% .125W F TC=0+-100	24546	C4-1/8-T0-90R9-F
A10R3	0757-0400	9		RESISTOR 90.9 1% .125W F TC=0+-100	24546	C4-1/8-T0-90R9-F
A10R4	0757-0400	9		RESISTOR 90.9 1% .125W F TC=0+-100	24546	C4-1/8-T0-90R9-F
A10R5	1810-0203	7		NETWORK-RES 8-PIN-SIP .1-PIN-SPCG	01121	
A10P6	1810-0203	7	NETWORK-RES 8-PIN-SIP .1-PIN-SPCG	01121		
A10R7	1810-0203	7	NETWORK-RES 8-PIN-SIP .1-PIN-SPCG	01121		
A10R8	069F-3447	4	RESISTOR 422 1% .125W F TC=0+-100	24546	C4-1/8-T0-422R-F	
A10R9	0757-0400	9	RESISTOR 90.9 1% .125W F TC=0+-100	24546	C4-1/8-T0-90R9-F	
A10R10	0757-0400	9	RESISTOR 90.9 1% .125W F TC=0+-100	24546	C4-1/8-T0-90R9-F	
A10R11	0757-0400	9	RESISTOR 90.9 1% .125W F TC=0+-100	24546	C4-1/8-T0-90R9-F	
A10P12	06H3-1215	9	16	RESISTOR 120 5% .25W FC TC=-400/+600	01121	CB1215
A10R13	06H3-1215	9		RESISTOR 120 5% .25W FC TC=-400/+600	01121	CB1215
A10R14	06H3-1215	9		RESISTOR 120 5% .25W FC TC=-400/+600	01121	CB1215
A10R15	06H3-1215	9		RESISTOR 120 5% .25W FC TC=-400/+600	01121	CB1215
A10R16	06H3-1215	9		RESISTOR 120 5% .25W FC TC=-400/+600	01121	CB1215
A10R17	06H3-1215	9	RESISTOR 120 5% .25W FC TC=-400/+600	01121	CB1215	
A10R18	06H3-1215	9	RESISTOR 120 5% .25W FC TC=-400/+600	01121	CB1215	
A10R19	06H3-1215	9	RESISTOR 120 5% .25W FC TC=-400/+600	01121	CB1215	
A10R20	06H3-1215	9	RESISTOR 120 5% .25W FC TC=-400/+600	01121	CB1215	
A10R21	06H3-1215	9	RESISTOR 120 5% .25W FC TC=-400/+600	01121	CB1215	
A10R22	06H3-1215	9	RESISTOR 120 5% .25W FC TC=-400/+600	01121	CB1215	
A10R23	06H3-1215	9	RESISTOR 120 5% .25W FC TC=-400/+600	01121	CB1215	
A10R24	06H3-1215	9	RESISTOR 120 5% .25W FC TC=-400/+600	01121	CB1215	
A10R25	06H3-1215	9	RESISTOR 120 5% .25W FC TC=-400/+600	01121	CB1215	
A10R26	06H3-1215	9	RESISTOR 120 5% .25W FC TC=-400/+600	01121	CB1215	
A10R27	06H3-1215	9	RESISTOR 120 5% .25W FC TC=-400/+600	01121	CB1215	
A10R28	2100-1174	7	RESISTOR, VAR 2K 10%	28480	2100-1174	
A10R29	0757-0400	9	RESISTOR 90.9 1% .125W F TC=0+-100	24546	C4-1/8-T0-90R9-F	
A10R30	0757-0400	9	RESISTOR 90.9 1% .125W F TC=0+-100	24546	C4-1/8-T0-90R9-F	
A10R31	0757-0400	9	RESISTOR 90.9 1% .125W F TC=0+-100	24546	C4-1/8-T0-90R9-F	
A10P32	0757-0400	9	RESISTOR 90.9 1% .125W F TC=0+-100	24546	C4-1/8-T0-90R9-F	
A10R33	0757-0400	9	RESISTOR 90.9 1% .125W F TC=0+-100	24546	C4-1/8-T0-90R9-F	
A10R34	0757-0400	9	RESISTOR 90.9 1% .125W F TC=0+-100	24546	C4-1/8-T0-90R9-F	
A10R35	0757-0400	9	RESISTOR 90.9 1% .125W F TC=0+-100	24546	C4-1/8-T0-90R9-F	
A10S1-			33	PUSHBUTTON SWITCH P.C. MOUNT	28480	5060-9436
A10S25	5060-9436	7		SWITCH, SLIDE DPDT-NS	28480	3101-2046
A10S27	3101-2046	7		SWITCH, PUSHBUTTON SPST NO	28480	3101-1074
A10S28	3101-1074	9		SWITCH, PUSHBUTTON SPST NO	28480	3101-1074
A10S29	3101-1074	9		SWITCH, SLIDE DPDT-NS	28480	3101-2046
A10S26	3101-2046	7		PUSHBUTTON SWITCH P.C. MOUNT	28480	5060-9436
A10S30-			4	TRANSISTOR ARRAY	28480	1858-0038
A10S38	5060-9436	7		TRANSISTOR ARRAY	28480	1858-0038
A10U1	1858-0038	4		TRANSISTOR ARRAY	28480	1858-0038
A10U2	1858-0038	4		TRANSISTOR ARRAY	28480	1858-0038
A10U3	1858-0038	4		TRANSISTOR ARRAY	28480	1858-0038
A10U4	1820-0668	7	3	IC BFR TTL NON-INV HEX 1-INP	01295	8N7407N
A10U5	1820-0668	7		IC BFR TTL NON-INV HEX 1-INP	01295	8N7407N
A10U6	1820-0668	7		IC BFR TTL NON-INV HEX 1-INP	01295	8N7407N
A10U7	1820-0668	7	IC DCDR TTL 4-T0-16-LINE 4-INP	01295	8N74154N	
A10U8	1820-0495	8	IC DCDR TTL 4-T0-16-LINE 4-INP	01295	8N74154N	
A10U9	1820-0495	8	IC DCDR TTL 4-T0-16-LINE 4-INP	01295	8N74154N	
A10W1	04274-61621	3	1	WIRING ASSEMBLY	28480	04274-61621
	0360-1706	9	1	CABLE TRANSITION	28480	0360-1706
				A10 MISCELLANEOUS PARTS		
	04274-26510	5		PC BOARD, BLANK	28480	04274-26510
A11	04274-66551	0	1	POWER SUPPLY BOARD ASSEMBLY	28480	
A11C1	0180-1073	1	1	CAPACITOR-FXD 22000uF +30-10% 16VDC	28480	0180-1073
A11C2	0180-1071	9	1	CAPACITOR-FXD 15000uF +30-10% 16VDC	28480	0180-1071
A11C3	0180-1072	0	2	CAPACITOR-FXD 10000uF +30-10% 25VDC	28480	0180-1072
A11C4	0180-1072	0	2	CAPACITOR-FXD 10000uF +30-10% 25VDC	28480	0180-1072
A11C5	0180-1074	2	2	CAPACITOR-FXD 470uF +5075-10% 100VDC	28480	0180-1074
A11C6	0180-1074	2		CAPACITOR-FXD 470uF +50-10% 100VDC	28480	0180-1074
A11C7	0180-1076	4	6	CAPACITOR-FXD 470uF +50-10% 35VDC	28480	0180-1076
A11C8	0180-1076	4		CAPACITOR-FXD 470uF +50-10% 35VDC	28480	0180-1076
A11C9	0180-1076	4		CAPACITOR-FXD 470uF +50-10% 35VDC	28480	0180-1076
A11C10	0180-1076	4		CAPACITOR-FXD 470uF +50-10% 35VDC	28480	0180-1076
A11C11	0180-1076	4		CAPACITOR-FXD 470uF +50-10% 35VDC	28480	0180-1076
A11C12	0180-1051	5		1	CAPACITOR, FXD 100 UF 16V M	28480
A11C13	0180-1076	4		CAPACITOR-FXD 470uF +50-10% 35VDC	28480	0180-1076
A11C14	0180-1075	3	4	CAPACITOR-FXD 2200uF +30-10% 16VDC	28480	0180-1075
A11C15	0180-1075	3		CAPACITOR-FXD 2200uF +30-10% 16VDC	28480	0180-1075

See introduction to this section for ordering information  
\*Indicates factory selected value

Table 6-3. Replaceable Parts (Cont'd).

Reference Designation	HP Part Number	C D	Qty	Description	Mfr Code	Mfr Part Number
A11C16	0180-1075	3		CAPACITOR-FXD 2200uF +30-10% 16VDC	28480	0180-1075
A11C17	0180-1075	3		CAPACITOR-FXD 2200uF +30-10% 16VDC	28480	0180-1075
A11CR1	1901-0416	5	10	DIODE-PWR RECT 200V 1.5A	28480	1901-0416
A11CR2	1901-0416	5		DIODE-PWR RECT 200V 1.5A	28480	1901-0416
A11CR3	1901-0416	5		DIODE-PWR RECT 200V 1.5A	28480	1901-0416
A11CR4	1901-0416	5		DIODE-PWR RECT 200V 1.5A	28480	1901-0416
A11CR5	1901-0416	5		DIODE-PWR RECT 200V 1.5A	28480	1901-0416
A11CR6	1901-0416	5		DIODE-PWR RECT 200V 1.5A	28480	1901-0416
A11CR7	1901-0416	5		DIODE-PWR RECT 200V 1.5A	28480	1901-0416
A11CR8	1901-0416	5		DIODE-PWR RECT 200V 1.5A	28480	1901-0416
A11CR9	1901-0416	5		DIODE-PWR RECT 200V 1.5A	28480	1901-0416
A11CR10	1901-0416	5		DIODE-PWR RECT 200V 1.5A	28480	1901-0416
A11CR11	1902-0021	0	2	DIODE-ZNR 1N2992R8 39V 5% DO-4 PD=10W	04713	1N2992R8
A11CR12	1902-0021	0		DIODE-ZNR 1N2992R8 39V 5% DO-4 PD=10W	04713	1N2992R8
A11CR13	1901-0364	2	2	DIODE-FW BRDG 200V 1A	28480	1901-0364
A11CR14	1901-0364	2		DIODE-FW BRDG 200V 1A	28480	1901-0364
A11CR15	1901-0025	2		DIODE-GEN PRP 100V 200MA DO-7	28480	1901-0025
A11CR16	1901-0025	2		DIODE-GEN PRP 100V 200MA DO-7	28480	1901-0025
A11CR17	1901-0025	2		DIODE-GEN PRP 100V 200MA DO-7	28480	1901-0025
A11CR18	1901-0025	2		DIODE-GEN PRP 100V 200MA DO-7	28480	1901-0025
A11CR19	1901-0025	2		DIODE-GEN PRP 100V 200MA DO-7	28480	1901-0025
A11CR20	1902-3094	3	1	DIODE-ZNR 5.11V 2% DO-7 PD=.4W TC=-.009%	28480	1902-3094
A11CR21	1902-0033	4	1	DIODE-ZNR 1N823 6.2V 5% DO-7 PD=.4W	24046	1N823
A11CR22	1901-0025	2		DIODE-GEN PRP 100V 200MA DO-7	28480	1901-0025
A11CR23	1901-0025	2		DIODE-GEN PRP 100V 200MA DO-7	28480	1901-0025
A11CR24	1901-0025	2		DIODE-GEN PRP 100V 200MA DO-7	28480	1901-0025
A11CR25	1901-0028	5	2	DIODE-PWR RECT 400V 750MA DO-29	28480	1901-0028
A11CR26	1901-0028	5		DIODE-PWR RECT 400V 750MA DO-29	28480	1901-0028
A11CR27	1901-0025	2		DIODE-GEN PRP 100V 200MA DO-7	28480	1901-0025
A11CR28	1901-0025	2		DIODE-GEN PRP 100V 200MA DO-7	28480	1901-0025
A11CR29	1901-0025	2		DIODE-GEN PRP 100V 200MA DO-7	28480	1901-0025
A11CR30	1902-1200	9	2	DIODE-ZNR 1N2980B 16V 5% DO-4 PD=10W	12954	1N2980B
A11CR31	1902-1200	9		DIODE-ZNR 1N2980B 16V 5% DO-4 PD=10W	12954	1N2980B
A11CR32	1902-1232	7	2	DIODE-ZNR 1N3997A 5.6V 5% DO-4 PD=10W	04713	1N3997A
A11CR33	1902-1232	7		DIODE-ZNR 1N3997A 5.6V 5% DO-4 PD=10W	04713	1N3997A
A11DP1	1970-0076	8	1	TUBE-ELECTRON SURGE V PCTR	28480	1970-0076
A11F1	2110-0007	4	3	FUSE 1A 250V SLO-BLO 1.25X.25 UL	75915	313001
A11F2	2110-0007	4		FUSE 1A 250V SLO-BLO 1.25X.25 UL	75915	313001
A11F3	2110-0303	3	1	FUSE 2A 250V SLO-BLO 1.25X.25 UL	28480	2110-0303
A11F4	2110-0014	3	1	FUSE 4A 250V SLO-BLO 1.25X.25 UL	75915	313004
A11F5	2110-0201	0	1	FUSE .25A 250V SLO-BLO 1.25X.25 UL	75915	313.250
A11F6	2110-0012	1	1	FUSE .5A 250V FAST-BLO 1.25X.25 UL	28480	2110-0012
A11F7	2110-0007	4		FUSE 1A 250V SLO-BLO 1.25X.25 UL	75915	313001
A11K1	0490-0238	5	1	RELAY-REED	28480	0490-0238
A11Q1	1853-0027	1		TRANSISTOR PNP SI TO-39 PD=1W FT=100MHZ	28480	1853-0027
A11Q2	1853-0027	1		TRANSISTOR PNP SI TO-39 PD=1W FT=100MHZ	28480	1853-0027
A11Q3	1854-0023	7	1	TRANSISTOR NPN SI TO-18 PD=360MW	04713	
A11Q4	1854-0448	2		TRANSISTOR NPN SI TO-39 PD=1W FT=100MHZ	28480	1854-0448
A11Q5	1854-0448	2		TRANSISTOR NPN SI TO-39 PD=1W FT=100MHZ	28480	1854-0448
A11Q6	1853-0281	9	4	TRANSISTOR PNP 2N2907A SI TO-18 PD=400MW	04713	2N2907A
A11Q7	1853-0281	9		TRANSISTOR PNP 2N2907A SI TO-18 PD=400MW	04713	2N2907A
A11Q8	1853-0281	9		TRANSISTOR PNP 2N2907A SI TO-18 PD=400MW	04713	2N2907A
A11Q9	1853-0281	9		TRANSISTOR PNP 2N2907A SI TO-18 PD=400MW	04713	2N2907A
A11R1	0690-1541	9	1	RESISTOR 150K 10X 1W CC TC=0+882	01121	6B1541
A11R2	0708-0001	9	1	RESISTOR 1K 10X 3W MO TC=0+250	27167	FP3-3-250-1001-K
A11R3	2100-3212	8	1	RESISTOR-TRMR 200 10% C TOP=ADJ 1-TRN	28480	2100-3212
A11R4	0812-0072	9	2	RESISTOR .23 5% 3W PW TC=0+90	28480	0812-0072
A11R5	06A3-3325	6		RESISTOR 3.3K 5% .25W FC TC=-400/+700	01121	C83325
A11R6	0812-0072	9		RESISTOR .23 5% 3W PW TC=0+90	28480	0812-0072
A11R7	06B3-1015	7		RESISTOR 100 5% .25W FC TC=-400/+500	01121	C81015
A11R8	06B3-1525	4	3	RESISTOR 1.5K 5% .25W FC TC=-400/+700	01121	C81525
A11R9	06B3-1015	7		RESISTOR 100 5% .25W FC TC=-400/+500	01121	C81015
A11R10	06B3-1035	1		RESISTOR 10K 5% .25W FC TC=-400/+700	01121	C81035
A11R11	069A-3445	3		RESISTOR 348 1% .125W F TC=0+100	24546	C4-1/8-T0-348R-F
A11R12	069A-3438	2	1	RESISTOR 147 1% .125W F TC=0+100	24546	C4-1/8-T0-147R-F
A11R13	0811-2771	7	1	RESISTOR .18 3% 3W PW TC=0+90	28480	0811-2771
A11R14	06B3-3325	6		RESISTOR 3.3K 5% .25W FC TC=-400/+700	01121	C83325
A11R15	0811-3290	7	2	RESISTOR .1 5% 2W PW TC=0+800	28480	0811-3290
A11R16	0811-3290	7		RESISTOR .1 5% 2W PW TC=0+800	28480	0811-3290
A11R17	06B3-8215	3	3	RESISTOR 820 5% .25W FC TC=-400/+600	01121	C88215
A11R18	06B3-1025	9		RESISTOR 1K 5% .25W FC TC=-400/+600	01121	C81025
A11R19	06B3-2235	5		RESISTOR 22K 5% .25W FC TC=-400/+800	01121	C82235
A11R20	06B6-1235	9	1	RESISTOR 12K 5% .5W CC TC=0+765	01121	E81235

See introduction to this section for ordering information  
\*Indicates factory selected value

Table 6-3. Replaceable Parts (Cont'd).

Reference Designation	HP Part Number	C D	Qty	Description	Mfr Code	Mfr Part Number
A11R21	0683-2235	5		RESISTOR 22K 5% .25W FC TC=-400/+800	01121	C82235
A11R22	0683-4725	2		RESISTOR 4.7K 5% .25W FC TC=-400/+700	01121	C84725
A11R23	0683-0475	1		RESISTOR 4.7 5% .25W FC TC=-400/+500	01121	C847G5
A11R24	0683-0475	1		RESISTOR 4.7 5% .25W FC TC=-400/+500	01121	C847G5
A11R25	0683-3325	6		RESISTOR 3.3K 5% .25W FC TC=-400/+700	01121	C83325
A11R26	0683-1015	7		RESISTOR 100 5% .25W FC TC=-400/+500	01121	C81015
A11R27	0757-0442	9		RESISTOR 10K 1% .125W F TC=0+/-100	24546	C4=1/8-T0=1002-F
A11R28	0757-0442	9		RESISTOR 10K 1% .125W F TC=0+/-100	24546	C4=1/8-T0=1002-F
A11R29	0683-1015	7		RESISTOR 100 5% .25W FC TC=-400/+500	01121	C81015
A11R30	0757-0438	3	1	RESISTOR 5.11K 1% .125W F TC=0+/-100	24546	C4=1/8-T0=5111-F
A11R31	0698-4471	6	1	RESISTOR 7.15K 1% .125W F TC=0+/-100	24546	C4=1/8-T0=7151-F
A11R32	0683-2225	3		RESISTOR 2.2K 5% .25W FC TC=-400/+700	01121	C82225
A11R33	0757-0280	3		RESISTOR 1K 1% .125W F TC=0+/-100	24546	C4=1/8-T0=1001-F
A11R34	0683-1015	7		RESISTOR 100 5% .25W FC TC=-400/+500	01121	C81015
A11R35	0683-4725	2		RESISTOR 4.7K 5% .25W FC TC=-400/+700	01121	C84725
A11R36	0683-1045	3		RESISTOR 100K 5% .25W FC TC=-400/+800	01121	C81045
A11R37	0683-2225	3		RESISTOR 2.2K 5% .25W FC TC=-400/+700	01121	C82225
A11R38	0683-2225	3		RESISTOR 2.2K 5% .25W FC TC=-400/+700	01121	C82225
A11R39	0683-1045	3		RESISTOR 100K 5% .25W FC TC=-400/+800	01121	C81045
A11R40	0757-0442	9		RESISTOR 10K 1% .125W F TC=0+/-100	24546	C4=1/8-T0=1002-F
A11R41	0757-0442	9		RESISTOR 10K 1% .125W F TC=0+/-100	24546	C4=1/8-T0=1002-F
A11U1	1820-0493	6	5	OP AMP GP 8-DIP-P	27014	LM307N
A11U2	1820-0493	6		OP AMP GP 8-DIP-P	27014	LM307N
A11U3	1820-0493	6		OP AMP GP 8-DIP-P	27014	LM307N
A11U4	1820-0493	6		OP AMP GP 8-DIP-P	27014	LM307N
A11U5	1820-0493	6		OP AMP GP 8-DIP-P	27014	LM307N
A11W1	1251-3198	7	2	CONNECTOR 15-PIN M POST TYPE	28480	1251-3198
A11W2	1251-3198	7		CONNECTOR 15-PIN M POST TYPE	28480	1251-3198
A11W3	1251-3197	6	1	CONNECTOR 12-PIN M POST TYPE	28480	1251-3197
				A11 MISCELLANEOUS PARTS		
	04274-26511	6		PC BOARD, BLANK	28480	04274-26511
A12	04274-66552	1	1	MOTHER BOARD ASSEMBLY	28480	
A12J1	1251-3141	0	1	CONNECTOR 50-PIN M RECTANGULAR	28480	1251-3141
A12XA1L	1251-5564	7	22	CONNECTOR-PC EDGE 22-CUNT/ROW 2-ROWS	28480	
A12XA1R	1251-5564	7		CONNECTOR-PC EDGE 22-CUNT/ROW 2-ROWS	28480	
A12XA2L	1251-5564	7		CONNECTOR-PC EDGE 22-CUNT/ROW 2-ROWS	28480	
A12XA2R	1251-5564	7		CONNECTOR-PC EDGE 22-CUNT/ROW 2-ROWS	28480	
A12XA3L	1251-5564	7		CONNECTOR-PC EDGE 22-CUNT/ROW 2-ROWS	28480	
A12XA3R	1251-5564	7		CONNECTOR-PC EDGE 22-CUNT/ROW 2-ROWS	28480	
A12XA4L	1251-5564	7		CONNECTOR-PC EDGE 22-CUNT/ROW 2-ROWS	28480	
A12XA4R	1251-5564	7		CONNECTOR-PC EDGE 22-CUNT/ROW 2-ROWS	28480	
A12XA5L	1251-5564	7		CONNECTOR-PC EDGE 22-CUNT/ROW 2-ROWS	28480	
A12XA5R	1251-5564	7		CONNECTOR-PC EDGE 22-CUNT/ROW 2-ROWS	28480	
A12XA6L	1251-5564	7		CONNECTOR-PC EDGE 22-CUNT/ROW 2-ROWS	28480	
A12XA6R	1251-5564	7		CONNECTOR-PC EDGE 22-CUNT/ROW 2-ROWS	28480	
A12XA7L	1251-5564	7		CONNECTOR-PC EDGE 22-CUNT/ROW 2-ROWS	28480	
A12XA7R	1251-5564	7		CONNECTOR-PC EDGE 22-CUNT/ROW 2-ROWS	28480	
A12XA8L	1251-5564	7		CONNECTOR-PC EDGE 22-CUNT/ROW 2-ROWS	28480	
A12XA8R	1251-5564	7		CONNECTOR-PC EDGE 22-CUNT/ROW 2-ROWS	28480	
A12XA9L	1251-5564	7		CONNECTOR-PC EDGE 22-CUNT/ROW 2-ROWS	28480	
A12XA9R	1251-5564	7		CONNECTOR-PC EDGE 22-CUNT/ROW 2-ROWS	28480	
A12XA11L	1251-4978	8	2	CONNECTOR-PC EDGE 15-CUNT/ROW 2-ROWS	28480	
A12XA11R	1251-4978	8		CONNECTOR-PC EDGE 15-CUNT/ROW 2-ROWS	28480	
A12XA21L	1251-5564	7		CONNECTOR-PC EDGE 22-CUNT/ROW 2-ROWS	28480	
A12XA21R	1251-5564	7		CONNECTOR-PC EDGE 22-CUNT/ROW 2-ROWS	28480	
A12XA22L	1251-5564	7		CONNECTOR-PC EDGE 22-CUNT/ROW 2-ROWS	28480	
A12XA22R	1251-5564	7		CONNECTOR-PC EDGE 22-CUNT/ROW 2-ROWS	28480	
				A12 MISCELLANEOUS PARTS		
	04274-26552	7		PC BOARD, BLANK	28480	
A13				NOT ASSIGNED		
A14				NOT ASSIGNED		
A15	04274-66515	4	1	HP-IB CONNECTOR BOARD ASSEMBLY	28480	04274-66515
A15J1	1251-3283	1	1	CONNECTOR 24-PIN F MICROBIBBON	28480	1251-3283
A15J2	1251-2159	8	2	CONNECTOR-PC EDGE 12-CUNT/ROW 2-ROWS	28480	1251-2159

See introduction to this section for ordering information  
\*Indicates factory selected value

Table 6-3. Replaceable Parts (Cont'd).

Reference Designation	HP Part Number	C D	Qty	Description	Mfr Code	Mfr Part Number
	04274-26515	0		PC BOARD, BLANK	28480	04274-26515
A16	04274-66516	5	1	DC BIAS CONNECTOR BOARD ASSEMBLY	28480	04274-66516
A16J1	1251-0292	6	1	CONNECTOR 24-PIN F MICRO RIBBON	28480	1251-0292
A16J2	1251-2159	8		CONNECTOR-PC EDGE 12-CONT/ROW 2-ROWS	28480	1251-2159
	04274-26515	0		PC BOARD, BLANK	28480	04274-26515
A17				NOT ASSIGNED		
A18				NOT ASSIGNED		
A19				NOT ASSIGNED		
A20				NOT ASSIGNED		
A21	04274-66521	2	1	DC BIAS(+/-35V) BOARD ASSEMBLY (OPTION 001 ONLY)	28480	04274-66521
A21C1	0160-2204	0		CAPACITOR-FXD 100PF +/-5% 300VDC MICA	28480	0160-2204
A21C2	0160-2242	6	1	CAPACITOR-FXD 2.4PF +/-25PF 500VDC CER	28480	0160-2242
A21C3	0160-2257	3		CAPACITOR-FXD 10PF +/-5% 500VDC CER 0+/-60	28480	0160-2257
A21C5	0160-2261	9	1	CAPACITOR-FXD 15PF +/-5% 500VDC CER 0+/-30	28480	0160-2261
A21C9	0140-0191	8	1	CAPACITOR-FXD 56PF +/-5% 300VDC MICA	72136	DM15E560J0300MV1CR
A21C10	0160-2055	9		CAPACITOR-FXD .01UF +80-20% 100VDC CER	28480	0160-2055
A21C11	0180-1050	4		CAPACITOR, FXD 100 UF 25VDCW	28480	0180-1050
A21C12	0180-1050	4		CAPACITOR, FXD 100 UF 25VDCW	28480	0180-1050
A21C13	0160-2055	9		CAPACITOR-FXD .01UF +80-20% 100VDC CER	28480	0160-2055
A21C14	0160-0859	7	1	CAPACITOR-FXD 1UF +/-10% 50VDC POLYE	28480	0160-0859
A21C14	0160-2055	9		CAPACITOR-FXD .01UF +80-20% 100VDC CER	28480	0160-2055
A21C15	0180-1084	4	1	CAPACITOR, FXD 100 UF 50VDCW BI	28480	0180-1084
A21C16	0180-1081	1	9	CAPACITOR, FXD 47 UF 50 VDCW AL	28480	0180-1081
A21C18	0180-1081	1		CAPACITOR, FXD 47 UF 50 VDCW AL	28480	0180-1081
A21C19	0180-1081	1		CAPACITOR, FXD 47 UF 50 VDCW AL	28480	0180-1081
A21C20	0180-1082	2	6	CAPACITOR, FXD 10 UF 100VDCW AL	28480	0180-1082
A21C21	0160-2055	9		CAPACITOR-FXD .01UF +80-20% 100VDC CER	28480	0160-2055
A21C22	0180-1050	4		CAPACITOR, FXD 100 UF 25VDCW	28480	0180-1050
A21C23	0180-1081	1		CAPACITOR, FXD 47 UF 50 VDCW AL	28480	0180-1081
A21C24	0180-1050	4		CAPACITOR, FXD 100 UF 25VDCW	28480	0180-1050
A21C25	0160-1050	4		CAPACITOR, FXD 100 UF 25VDCW	28480	0180-1050
A21C26	0160-2055	9		CAPACITOR-FXD .01UF +80-20% 100VDC CER	28480	0160-2055
A21C27	0180-2951	6	6	CAPACITOR-FXD 33UF+/-20% 16VDC AL	28480	0180-2951
A21C28	0180-2951	6		CAPACITOR-FXD 33UF+/-20% 16VDC AL	28480	0180-2951
A21C29	0180-2951	6		CAPACITOR-FXD 33UF+/-20% 16VDC AL	28480	0180-2951
A21C30	0180-1082	2		CAPACITOR, FXD 10 UF 100VDCW AL	28480	0180-1082
A21CR1	1902-3234	3	4	DIODE-ZNR 19.6V 5% DO-7 PDM.4W TC=+.073%	28480	1902-3234
A21CR2	1902-3234	3		DIODE-ZNR 19.6V 5% DO-7 PDM.4W TC=+.073%	28480	1902-3234
A21CR3	1902-3234	3		DIODE-ZNR 19.6V 5% DO-7 PDM.4W TC=+.073%	28480	1902-3234
A21CR4	1902-3234	3		DIODE-ZNR 19.6V 5% DO-7 PDM.4W TC=+.073%	28480	1902-3234
A21CR5	1901-0025	2		DIODE-GEN PRP 100V 200MA DO-7	28480	1901-0025
A21CR6	1901-0025	2		DIODE-GEN PRP 100V 200MA DO-7	28480	1901-0025
A21CR7	1901-0025	2		DIODE-GEN PRP 100V 200MA DO-7	28480	1901-0025
A21CR8	1901-0025	2		DIODE-GEN PRP 100V 200MA DO-7	28480	1901-0025
A21CR9	1901-0025	2		DIODE-GEN PRP 100V 200MA DO-7	28480	1901-0025
A21CR10	1901-0025	2		DIODE-GEN PRP 100V 200MA DO-7	28480	1901-0025
A21CR11	1901-0025	2		DIODE-GEN PRP 100V 200MA DO-7	28480	1901-0025
A21CR12	1902-1259	8	4	DIODE-ZNR 1N5357B 20V 5% PDM5W IR=500NA	04713	1N5357B
A21CR13	1902-1259	8		DIODE-ZNR 1N5357B 20V 5% PDM5W IR=500NA	04713	1N5357B
A21CR14	1902-1259	8		DIODE-ZNR 1N5357B 20V 5% PDM5W IR=500NA	04713	1N5357B
A21CR15	1902-1259	8		DIODE-ZNR 1N5357B 20V 5% PDM5W IR=500NA	04713	1N5357B
A21CR16	1901-0025	2		DIODE-GEN PRP 100V 200MA DO-7	28480	1901-0025
A21CR17	1901-0025	2		DIODE-GEN PRP 100V 200MA DO-7	28480	1901-0025
A21CR18	1901-0025	2		DIODE-GEN PRP 100V 200MA DO-7	28480	1901-0025
A21CR19	1901-0025	2		DIODE-GEN PRP 100V 200MA DO-7	28480	1901-0025
A21CR20	1901-0025	2		DIODE-GEN PRP 100V 200MA DO-7	28480	1901-0025
A21CR21	1901-0025	2		DIODE-GEN PRP 100V 200MA DO-7	28480	1901-0025
A21CR22	1901-0025	2		DIODE-GEN PRP 100V 200MA DO-7	28480	1901-0025
A21CR23	1901-0460	9	2	DIODE-STABILISOR 30V 150MA DO-7	28480	1901-0460
A21CR24	1901-0460	9		DIODE-STABILISOR 30V 150MA DO-7	28480	1901-0460
A21CR25	1901-0025	2		DIODE-GEN PRP 100V 200MA DO-7	28480	1901-0025
A21CR26	1901-0025	2		DIODE-GEN PRP 100V 200MA DO-7	28480	1901-0025
A21CR27	1902-3122	8	2	DIODE-ZNR 6.65V 2% DO-7 PDM.4W TC=+.038%	28480	1902-3122
A21CR28	1901-0025	2		DIODE-GEN PRP 100V 200MA DO-7	28480	1901-0025
A21CR29	1901-0025	2		DIODE-GEN PRP 100V 200MA DO-7	28480	1901-0025

See introduction to this section for ordering information  
\*Indicates factory selected value

Table 6-3. Replaceable Parts (Cont'd).

Reference Designation	HP Part Number	C	D	Qty	Description	Mfr Code	Mfr Part Number
A21J1	1200-0473	8		4	SOCKET-IC 16-CONT DIP DIP-SLDR	28480	1200-0473
A21J2	1200-0473	8			SOCKET-IC 16-CONT DIP DIP-SLDR	28480	1200-0473
A21J3	1200-0654	1			SOCKET-IC 40-CONT	28480	
A21J4	1200-0658	1		2	SOCKET-IC 24-CONT DIP-SLDR	28480	1200-0658
A21K1	0490-0240	9			RELAY-REED 1A	28480	0490-0240
A21K2	0490-0242	1		1	RELAY-REED	28480	0490-0242
A21L1	9100-1618	1		4	COIL-MLD 5.6UH 10% Q=45 .155DX,375LG-NOM	28480	9100-1618
A21L2	9100-1618	1			COIL-MLD 5.6UH 10% Q=45 .155DX,375LG-NOM	28480	9100-1618
A21L3	9100-3139	5			COIL 75UH 15% .5DX,875LG-NOM	28480	9100-3139
A21O1	1853-0204	6		7	TRANSISTOR PNP 2N4920 SI PD=30W FT=3MHZ	04713	2N4920
A21O1	1854-0271	9		2	TRANSISTOR PNP SI TO=39 PD=1W FT=150MHZ	28480	1854-0271
A21O2	1853-0232	0		1	TRANSISTOR PNP SI TO=39 PD=1W FT=200MHZ	28480	1853-0232
A21O3	1853-0080	6		12	TRANSISTOR PNP SI PD=300MW FT=30MHZ	28480	1853-0080
A21O4	1854-0474	4		12	TRANSISTOR NPN SI PD=310MW FT=100MHZ	04713	2N5551
A21O5	1854-0474	4			TRANSISTOR NPN SI PD=310MW FT=100MHZ	04713	2N5551
A21O6	1853-0080	6			TRANSISTOR PNP SI PD=300MW FT=30MHZ	28480	1853-0080
A21O7	1855-0111	8			TRANSISTOR J-FET N-CHAN Si	28480	1855-0111
A21O8	1855-0111	8			TRANSISTOR J-FET N-CHAN Si	28480	1855-0111
A21O9	1855-0111	8			TRANSISTOR J-FET N-CHAN Si	28480	1855-0111
A21O10	1855-0111	8			TRANSISTOR J-FET N-CHAN Si	28480	1855-0111
A21O11	1855-0111	8			TRANSISTOR J-FET N-CHAN Si	28480	1855-0111
A21O12	1855-0111	8			TRANSISTOR J-FET N-CHAN Si	28480	1855-0111
A21O13	1853-0204	6			TRANSISTOR PNP 2N4920 SI PD=30W FT=3MHZ	04713	2N4920
A21O14	1853-0080	6			TRANSISTOR PNP SI PD=300MW FT=30MHZ	28480	1853-0080
A21O15	1854-0474	4			TRANSISTOR NPN SI PD=310MW FT=100MHZ	04713	2N5551
A21O16	1853-0080	6			TRANSISTOR PNP SI PD=300MW FT=30MHZ	28480	1853-0080
A21O17	1853-0204	6			TRANSISTOR PNP 2N4920 SI PD=30W FT=3MHZ	04713	2N4920
A21O18	1853-0080	6			TRANSISTOR PNP SI PD=300MW FT=30MHZ	28480	1853-0080
A21O19	1853-0204	6			TRANSISTOR PNP 2N4920 SI PD=30W FT=3MHZ	04713	2N4920
A21O20	1854-0347	0		4	TRANSISTOR NPN 2N4923 SI PD=30W FT=3MHZ	04713	2N4923
A21O21	1854-0474	4			TRANSISTOR NPN SI PD=310MW FT=100MHZ	04713	2N5551
A21O22	1853-0080	6			TRANSISTOR PNP SI PD=300MW FT=30MHZ	28480	1853-0080
A21O23	1854-0474	4			TRANSISTOR NPN SI PD=310MW FT=100MHZ	04713	2N5551
A21O24	1854-0347	0			TRANSISTOR NPN 2N4923 SI PD=30W FT=3MHZ	04713	2N4923
A21O25	1854-0474	4			TRANSISTOR NPN SI PD=310MW FT=100MHZ	04713	2N5551
A21O26	1854-0347	0			TRANSISTOR NPN 2N4923 SI PD=30W FT=3MHZ	04713	2N4923
A21O27	1853-0080	6			TRANSISTOR PNP SI PD=300MW FT=30MHZ	28480	1853-0080
A21O28	1854-0474	4			TRANSISTOR NPN SI PD=310MW FT=100MHZ	04713	2N5551
A21O29	1853-0204	6			TRANSISTOR PNP 2N4920 SI PD=30W FT=3MHZ	04713	2N4920
A21R1	0683-1835	9			RESISTOR 18K 5% .25W FC TC=-400/+800	01121	C81835
A21R3	0683-8215	3			RESISTOR 820 5% .25W FC TC=-400/+600	01121	C88215
A21R4	0683-2225	3			RESISTOR 2.2K 5% .25W FC TC=-400/+700	01121	C82225
A21R5	0683-1225	1		11	RESISTOR 1.2K 5% .25W FC TC=-400/+700	01121	C81225
A21R6	0683-1235	3			RESISTOR 12K 5% .25W FC TC=-400/+800	01121	C81235
A21R7	0683-5615	1			RESISTOR 560 5% .25W FC TC=-400/+600	01121	C85615
A21R8	2100-3274	2			RESISTOR-TRMR 10K 10% C SIDE-ADJ 1-TRN	28480	2100-3274
A21R9	0683-1835	9			RESISTOR 18K 5% .25W FC TC=-400/+800	01121	C81835
A21R10	0683-1835	9			RESISTOR 18K 5% .25W FC TC=-400/+800	01121	C81835
A21R11	2100-3274	2			RESISTOR-TRMR 10K 10% C SIDE-ADJ 1-TRN	28480	2100-3274
A21R12	2100-3274	2			RESISTOR-TRMR 10K 10% C SIDE-ADJ 1-TRN	28480	2100-3274
A21R13	2100-3426	6			RESISTOR-TRMR 20 10% C SIDE-ADJ 1-TRN	28480	2100-3426
A21R14	0683-1515	2			RESISTOR 150 5% .25W FC TC=-400/+600	01121	C81515
A21R16	0683-8215	3			RESISTOR 820 5% .25W FC TC=-400/+600	01121	C88215
A21R17	0683-2225	3			RESISTOR 2.2K 5% .25W FC TC=-400/+700	01121	C82225
A21R18	0683-1225	1			RESISTOR 1.2K 5% .25W FC TC=-400/+700	01121	C81225
A21R19	0683-1235	3			RESISTOR 12K 5% .25W FC TC=-400/+800	01121	C81235
A21R20	0683-5615	1			RESISTOR 560 5% .25W FC TC=-400/+600	01121	C85615
A21R21	0698-3260	9		2	RESISTOR 464K 1% .125W F TC=0+/-100	28480	0698-3260
A21R22	0757-0458	7			RESISTOR 51.1K 1% .125W F TC=0+/-100	24546	C4-1/8-T0-5112-F
A21R23	0757-0458	7			RESISTOR 51.1K 1% .125W F TC=0+/-100	24546	C4-1/8-T0-5112-F
A21R24	0698-3260	9			RESISTOR 464K 1% .125W F TC=0+/-100	28480	0698-3260
A21R25	0683-4725	2			RESISTOR 4.7K 5% .25W FC TC=-400/+700	01121	C84725
A21R26	0699-0391	3		4	RESISTOR 25K .1% .125W F TC=0+/-25	28480	0699-0391
A21R27	0699-0391	3			RESISTOR 25K .1% .125W F TC=0+/-25	28480	0699-0391
A21R28	0683-4725	2			RESISTOR 4.7K 5% .25W FC TC=-400/+700	01121	C84725
A21R29	0698-3442	9		4	RESISTOR 237 1% .125W F TC=0+/-100	24546	C4-1/8-T0-237R-F
A21R30	0757-0403	2			RESISTOR 121 1% .125W F TC=0+/-100	24546	C4-1/8-T0-121R-F
A21R33	0699-0390	2		2	RESISTOR 450K .1% .125W F TC=0+/-25	28480	0699-0390
A21R34	0698-2198	0		2	RIFXD MET FLM 50K OHM 0.1% 1/8W	28480	0698-2198
A21R35	0683-8205	1		1	RESISTOR 82 5% .25W FC TC=-400/+500	01121	C88205
A21R36	0683-1225	1			RESISTOR 1.2K 5% .25W FC TC=-400/+700	01121	C81225
A21R37	0683-5615	1			RESISTOR 560 5% .25W FC TC=-400/+600	01121	C85615
A21R38	0698-2198	0			RIFXD MET FLM 50K OHM 0.1% 1/8W	28480	0698-2198
A21R39	0699-0390	2			RESISTOR 450K .1% .125W F TC=0+/-25	28480	0699-0390

See introduction to this section for ordering information  
\*Indicates factory selected value

Table 6-3. Replaceable Parts (Cont'd).

Reference Designation	HP Part Number	C D	Qty	Description	Mfr Code	Mfr Part Number
A21R40	0683-5625	3		RESISTOR 5.6K 5% .25W FC TC=-400/+700	01121	C85625
A21R41	0683-5625	3		RESISTOR 5.6K 5% .25W FC TC=-400/+700	01121	C85625
A21R42	0683-5625	3		RESISTOR 5.6K 5% .25W FC TC=-400/+700	01121	C85625
A21R43	0683-5625	3		RESISTOR 5.6K 5% .25W FC TC=-400/+700	01121	C85625
A21R44	0683-1235	3		RESISTOR 12K 5% .25W FC TC=-400/+800	01121	C81235
A21R45	0683-1235	3		RESISTOR 12K 5% .25W FC TC=-400/+800	01121	C81235
A21R46	0683-3335	8		RESISTOR 33K 5% .25W FC TC=-400/+800	01121	C83335
A21R47	0683-1835	9		RESISTOR 18K 5% .25W FC TC=-400/+800	01121	C81835
A21R48	2100-3353	8		RESISTOR-TRMR 20K 10% C BIDE-ADJ 1-TRN	32997	3386K-Y46-203
A21R49	0683-5625	3		RESISTOR 5.6K 5% .25W FC TC=-400/+700	01121	C85625
A21R50	0698-3442	9		RESISTOR 237 1% .125W F TC=0+-100	24546	C4-1/8-T0-237R-F
A21R51	0698-3442	9		RESISTOR 237 1% .125W F TC=0+-100	24546	C4-1/8-T0-237R-F
A21R52	0698-3442	9		RESISTOR 237 1% .125W F TC=0+-100	24546	C4-1/8-T0-237R-F
A21R53	0683-1835	9		RESISTOR 18K 5% .25W FC TC=-400/+800	01121	C81835
A21R54	0683-1505	0	2	RESISTOR 15 5% .25W FC TC=-400/+500	01121	C81505
A21R55	0683-3335	8		RESISTOR 33K 5% .25W FC TC=-400/+800	01121	C83335
A21R56	0683-5605	9	3	RESISTOR 56 5% .25W FC TC=-400/+500	01121	C85605
A21R57	0698-3450	9		RESISTOR 42.2K 1% .125W F TC=0+-100	24546	C4-1/8-T0-4222-F
A21R58	0698-3450	9		RESISTOR 42.2K 1% .125W F TC=0+-100	24546	C4-1/8-T0-4222-F
A21R59	0683-4735	4		RESISTOR 47K 5% .25W FC TC=-400/+800	01121	C84735
A21R60	0683-1225	1		RESISTOR 1.2K 5% .25W FC TC=-400/+700	01121	C81225
A21R61	0683-1235	3		RESISTOR 12K 5% .25W FC TC=-400/+800	01121	C81235
A21R62	0683-1235	3		RESISTOR 12K 5% .25W FC TC=-400/+800	01121	C81235
A21R63	0683-1225	1		RESISTOR 1.2K 5% .25W FC TC=-400/+700	01121	C81225
A21R64	0683-3335	8		RESISTOR 33K 5% .25W FC TC=-400/+800	01121	C83335
A21R65	0683-5615	1		RESISTOR 560 5% .25W FC TC=-400/+800	01121	C85615
A21R66	0757-0439	4		RESISTOR 6.81K 1% .125W F TC=0+-100	24546	C4-1/8-T0-6811-F
A21R67	0757-0439	4		RESISTOR 6.81K 1% .125W F TC=0+-100	24546	C4-1/8-T0-6811-F
A21R68	1810-0269	3		NETWORK-RES 9-PIN-SIP .1-PIN-SPCG	28480	1810-0269
A21R69	0683-1055	5		RESISTOR 1M 5% .25W FC TC=-800/+900	01121	C81055
A21R70	0683-1835	9		RESISTOR 18K 5% .25W FC TC=-400/+800	01121	C81835
A21R71	0683-1505	0		RESISTOR 15 5% .25W FC TC=-400/+500	01121	C81505
A21R72	0683-3335	8		RESISTOR 33K 5% .25W FC TC=-400/+800	01121	C83335
A21R73	0683-5605	9		RESISTOR 56 5% .25W FC TC=-400/+500	01121	C85605
A21R74	0683-4725	2		RESISTOR 4.7K 5% .25W FC TC=-400/+700	01121	C84725
A21R75	0683-3335	8		RESISTOR 33K 5% .25W FC TC=-400/+800	01121	C83335
A21R76	0683-4735	4		RESISTOR 47K 5% .25W FC TC=-400/+800	01121	C84735
A21R77	0683-1225	1		RESISTOR 1.2K 5% .25W FC TC=-400/+700	01121	C81225
A21R78	0683-1235	3		RESISTOR 12K 5% .25W FC TC=-400/+800	01121	C81235
A21R79	0683-1835	9		RESISTOR 18K 5% .25W FC TC=-400/+800	01121	C81835
A21R80	0683-1225	1		RESISTOR 1.2K 5% .25W FC TC=-400/+700	01121	C81225
A21R81	0683-5605	9		RESISTOR 56 5% .25W FC TC=-400/+500	01121	C85605
A21R82	1810-0269	3		NETWORK-RES 9-PIN-SIP .1-PIN-SPCG	28480	1810-0269
A21R83	2100-3252	6	2	RESISTOR-TRMR 5K 10% C TOP-ADJ 1-TRN	28480	2100-3252
A21R84	1810-0269	3		NETWORK-RES 9-PIN-SIP .1-PIN-SPCG	28480	1810-0269
A21R85	0683-1235	3		RESISTOR 12K 5% .25W FC TC=-400/+800	01121	C81235
A21R86	0683-5625	3		RESISTOR 5.6K 5% .25W FC TC=-400/+700	01121	C85625
A21U1	1826-0319	7		OP AMP BIFET T0-99	27014	LF356M
A21U2	1826-0357	7		OP AMP WB T0-99	27014	LF357M
A21U3	1826-0319	3		OP AMP BIFET T0-99	27014	LF356M
A21U4	1820-1856	7	2	CONV 12-B=D/A 24-DIP=C	24355	AD563KD/BCD
A21U5	1820-1730	6		IC FF TTL LS D-TYPE POS-EDGE-TRIG COM	01295	8N74L8273N
A21U6	1820-0122	0		IC 7805 V RGLTR T0-220	07263	7805UC
A21U7	1820-0174	2		COMPARATOR GP QUAD 14-DIP-P	28480	1820-0174
A21U8	1820-1730	6		IC FF TTL LS D-TYPE POS-EDGE-TRIG COM	01295	8N74L8273N
A21U9	1826-0222	1		OP AMP GP QUAD 14-DIP-P	07263	U44136PC
A21U10	1820-1197	9		IC GATE TTL LS NAND QUAD 2-INP	01295	8N74LS00N
A21U11	1820-1481	4		IC PIA NMOS	04713	MC6821L
A21U12	1820-2024	3		IC DRVR TTL LS LINE DRVR OCTL	01295	8N74LS244N
A21U13	1820-2024	3		IC DRVR TTL LS LINE DRVR OCTL	01295	8N74LS244N
A21 MISCELLANEOUS PARTS						
	04274-26521	8		PC BOARD, BLANK	28480	04274-26521
A22	04274-66522	3	1	HP-IB INTERFACE BOARD ASSEMBLY (OPTION 101 ONLY)	28480	04274-66522
A22C1	0160-2055	9		CAPACITOR-FXD .01UF +80-20% 100VDC CER	28480	0160-2055
A22C2	0160-2055	9		CAPACITOR-FXD .01UF +80-20% 100VDC CER	28480	0160-2055
A22C3	0160-2055	9		CAPACITOR-FXD .01UF +80-20% 100VDC CER	28480	0160-2055
A22C4	0160-2055	9		CAPACITOR-FXD .01UF +80-20% 100VDC CER	28480	0160-2055
A22C5	0160-0228	6		CAPACITOR-FXD 22UF+10% 15VDC TA	56289	150D226X901582
A22J1	1200-0654	1		SOCKET-IC 40-CONT	28480	

See introduction to this section for ordering information  
\*Indicates factory selected value

Table 6-3. Replaceable Parts (Cont'd).

Reference Designation	HP Part Number	C D	Qty	Description	Mfr Code	Mfr Part Number
A22L1 A22L2	9100-3139 9100-1788	5 6		COIL 75UH 15% .5DX .875LG-NOM CHOKE-WIDE BAND 2MAX=680 OHMS 180 MHZ	28480 02114	9100-3139 VK200 20/48
A22P1 A22P2 A22P3 A22P4 A22P5	1A10-0269 0683-1835 0683-4725 0683-4725 0683-4725	3 9 2 2 2		NETWORK-RES 9-PIN-SIP .1-PIN-SPCG RESISTOR 18K 5% .25W FC TC=+400/+600 RESISTOR 4.7K 5% .25W FC TC=+400/+700 RESISTOR 4.7K 5% .25W FC TC=+400/+700 RESISTOR 4.7K 5% .25W FC TC=+400/+700	28480 01121 01121 01121 01121	1810-0269 CB1835 CB4725 CB4725 CB4725
A22P6 A22P7	0683-4725 0683-4725	2 2		RESISTOR 4.7K 5% .25W FC TC=+400/+700 RESISTOR 4.7K 5% .25W FC TC=+400/+700	01121 01121	CB4725 CB4725
A22S1	3101-1973	7		SWITCH-SL 7-1A DIP-SLIDE-ASSY .1A 50VDC	28480	3101-1973
A22U1 A22U2 A22U3 A22U4 A22U5	1A20-1873 1A20-1204 1A20-2113 1A20-1199 1A20-2058	8 9 1 1 3	1 1 1 4	IC BFR TTL LS INV OCTL 2-INP IC GATE TTL LS NAND DUAL 4-INP IC MICPROC-ACCESS NMOS IC INV TTL LS HEX 1-INP IC MISC TTL S QUAD	27014 01295 01295 01295 28480	DM61L996N 8N74LS20N MC68488L 8N74LS04N 1820-2058
A22U6 A22UR A22U9 A22U10	1820-2058 1A20-1144 1A20-2058 1A20-2058	3 6 3 3		IC MISC TTL S QUAD IC GATE TTL LS NOR QUAD 2-INP IC MISC TTL S QUAD IC MISC TTL S QUAD	28480 01295 28480 28480	1820-2058 8N74LS02N 1820-2058 1820-2058
A22W1 A22W2	8159-0005 8159-0005	0 0		WIRE 22AWG W PVC 1X22 80C WIRE 22AWG W PVC 1X22 80C	28480 28480	8159-0005 8159-0005
A22 MISCELLANEOUS PARTS						
	04274-26522	9		PC BOARD, BLANK	28480	04274-26522
A23	04274-66523	4	1	DC BIAS (+/-100V) BOARD ASSEMBLY (OPTION 002 ONLY)	28480	04274-66523
A23C1 A23C2 A23C3 A23C4 A23C5 A23C6	0160-0210 0160-2055 0160-2055 0180-1050 0160-2055	2 9 9 4 9	1	CAPACITOR-FXD 270PF +/-5% 300VDC MICA CAPACITOR-FXD .01UF +80-20% 100VDC CER CAPACITOR-FXD .01UF +80-20% 100VDC CER CAPACITOR-FXD 100UF +50-10% 25VDC CAPACITOR-FXD .01UF +80-20% 100VDC CER	72136 28480 28480 28480 28480	DM15F271J0300WV1CR 0160-2055 0160-2055 0180-1050 0160-2055
A23C7 A23C8 A23C9 A23C10 A23C11	0160-0127 0160-2055 0160-2055 0180-1080 0180-1080	2 9 9 0 0	2	CAPACITOR-FXD 1UF +/-20% 25VDC CER CAPACITOR-FXD .01UF +80-20% 100VDC CER CAPACITOR-FXD .01UF +80-20% 100VDC CER CAPACITOR-FXD 4.7UF +100-10% 160VDC CAPACITOR-FXD 4.7UF +100-10% 160VDC	28480 28480 28480 28480 28480	0160-0127 0160-2055 0160-2055 0180-1080 0180-1080
A23C12 A23C13 A23C14 A23C15 A23C16	0180-1082 0180-1082 0160-2055 0180-1050 0170-0066	2 2 9 4 9	2	CAPACITOR-FXD 10UF +50-10% 100VDC CAPACITOR-FXD 10UF +50-10% 100VDC CAPACITOR-FXD .01UF +80-20% 100VDC CER CAPACITOR-FXD 100UF +50-10% 25VDC CAPACITOR-FXD .027UF +/-10% 200VDC POLYE	28480 28480 28480 28480 28480	0180-1082 0180-1082 0160-2055 0180-1050 0170-0066
A23C17 A23C18 A23C19 A23C20 A23C21	0170-0066 0160-3456 0160-3456 0160-3456 0180-1050	9 6 6 6 4		CAPACITOR-FXD .027UF +/-10% 200VDC POLYE CAPACITOR-FXD 1000PF +/-10% 1KVDC CER CAPACITOR-FXD 1000PF +/-10% 1KVDC CER CAPACITOR-FXD 1000PF +/-10% 1KVDC CER CAPACITOR-FXD 100UF +50-10% 25VDC	28480 28480 28480 28480 28480	0170-0066 0160-3456 0160-3456 0160-3456 0180-1050
A23C22 A23C23 A23C24 A23C25 A23C26	0180-1050 0180-1081 0180-1081 0180-1081 0180-1081	4 1 1 1 1		CAPACITOR-FXD 100UF +50-10% 25VDC CAPACITOR-FXD 47UF +50-10% 50VDC CAPACITOR-FXD 47UF +50-10% 50VDC CAPACITOR-FXD 47UF +50-10% 50VDC CAPACITOR-FXD 47UF +50-10% 50VDC	28480 28480 28480 28480 28480	0180-1050 0180-1081 0180-1081 0180-1081 0180-1081
A23C27 A23C28 A23C29 A23C30 A23C31	0180-1082 0180-1082 0180-1050 0160-2055 0180-1081	2 2 4 9 1		CAPACITOR-FXD 10UF +50-10% 100VDC CAPACITOR-FXD 10UF +50-10% 100VDC CAPACITOR-FXD 100UF +50-10% 25VDC CAPACITOR-FXD .01UF +80-20% 100VDC CER CAPACITOR-FXD 47UF +50-10% 50VDC	28480 28480 28480 28480 28480	0180-1082 0180-1082 0180-1050 0160-2055 0180-1081
A23C32 A23C33 A23C34 A23C35 A23C36	0180-1050 0180-1050 0160-2055 0180-2951 0180-2951	4 4 9 6 6		CAPACITOR-FXD 100UF +50-10% 25DC CAPACITOR-FXD 100UF +50-10% 25DC CAPACITOR-FXD .01UF +80-20% 100VDC CER CAPACITOR-FXD 33UF +/-20% 16VDC AL CAPACITOR-FXD 33UF +/-20% 16VDC AL	28480 28480 28480 28480 28480	0180-1050 0180-1050 0160-2055 0180-2951 0180-2951
A23C37	0180-2951	6		CAPACITOR-FXD 33UF +/-20% 16VDC AL	28480	0180-2951
A23CR1 A23CR2 A23CR3 A23CR4 A23CR5	1902-3385 1902-3385 1902-3385 1902-3385 1901-0025	5 5 5 5 2	4	DIODE-ZNR 69.8V 2% DO-7 PDM.4W TC=+.079% DIODE-ZNR 69.8V 2% DO-7 PDM.4W TC=+.079% DIODE-ZNR 69.8V 2% DO-7 PDM.4W TC=+.079% DIODE-ZNR 69.8V 2% DO-7 PDM.4W TC=+.079% DIODE-GEN PRP 100V 200MA DO-7	28480 28480 28480 28480 28480	1902-3385 1902-3385 1902-3385 1902-3385 1901-0025
A23CR6 A23CR7 A23CR8 A23CR9 A23CR10	1901-0025 1901-0025 1901-0033 1901-0033 1901-0033	2 2 2 2 2		DIODE-GEN PRP 100V 200MA DO-7 DIODE-GEN PRP 100V 200MA DO-7 DIODE-GEN PRP 180V 200MA DO-7 DIODE-GEN PRP 180V 200MA DO-7 DIODE-GEN PRP 180V 200MA DO-7	28480 28480 28480 28480 28480	1901-0025 1901-0025 1901-0033 1901-0033 1901-0033

See introduction to this section for ordering information  
\*Indicates factory selected value

Table 6-3. Replaceable Parts (Cont'd).

Reference Designation	HP Part Number	C D	Qty	Description	Mfr Code	Mfr Part Number
A23CR11	1901-0033	2		DIODE-GEN PRP 180V 200MA DD-7	28480	1901-0033
A23CR12	1901-0025	2		DIODE-GEN PRP 100V 200MA DD-7	28480	1901-0025
A23CR13	1901-0025	2		DIODE-GEN PRP 100V 200MA DD-7	28480	1901-0025
A23CR14	1901-0025	2		DIODE-GEN PRP 100V 200MA DD-7	28480	1901-0025
A23CR15	1902-3122	8		DIODE-ZNR 6.65V 2X DD-7 PD=4W TC=+.038X	28480	1902-3122
A23J1	1200-0473	8		SOCKET-IC 16-CONT DIP DIP-8LDR	28480	1200-0473
A23J2	1200-0473	8		SOCKET-IC 16-CONT DIP DIP-8LDR	28480	1200-0473
A23J3	1200-0654	1		SOCKET-IC 40-CONT	28480	
A23J4	1200-0658	1		SOCKET-IC 24-CONT DIP-8LDR	28480	1200-0658
A23L1	9140-0137	1	6	COIL-MLD 1MH 5X Q=60 .19DX,44LG-NOM	28480	9140-0137
A23L2	9140-0137	1		COIL-MLD 1MH 5X Q=60 .19DX,44LG-NOM	28480	9140-0137
A23L3	9140-0137	1		COIL-MLD 1MH 5X Q=60 .19DX,44LG-NOM	28480	9140-0137
A23L4	9140-0137	1		COIL-MLD 1MH 5X Q=60 .19DX,44LG-NOM	28480	9140-0137
A23L5	9140-0137	1		COIL-MLD 1MH 5X Q=60 .19DX,44LG-NOM	28480	9140-0137
A23L6	9140-0137	1		COIL-MLD 1MH 5X Q=60 .19DX,44LG-NOM	28480	9140-0137
A23L7	9100-1618	1		COIL-MLD 5.6UH 10X Q=45 .155DX,375LG-NOM	28480	9100-1618
A23L8	9100-1618	1		COIL-MLD 5.6UH 10X Q=45 .155DX,375LG-NOM	28480	9100-1618
A23L9	9100-3139	5		COIL 75UH 15X .5DX,875LG-NOM	28480	9100-3139
A23O1	1853-0414	0	1	TRANSISTOR PNP 2N6423 SI TO-66 PD=35W	04713	2N6423
A23O2	1854-0324	3	1	TRANSISTOR NPN 2N3739 SI TO-66 PD=20W	04713	2N3739
A23O3	1854-0474	4		TRANSISTOR NPN SI PD=310MW FT=100MHZ	04713	2N5551
A23O4	1853-0080	6		TRANSISTOR PNP SI PD=300MW FT=30MHZ	28480	1853-0080
A23O5	1855-0111	8		TRANSISTOR J-FET N-CHAN SI	28480	1855-0111
A23O6	1855-0111	8		TRANSISTOR J-FET N-CHAN SI	28480	1855-0111
A23O7	1853-0204	6		TRANSISTOR PNP 2N4920 SI PD=30W FT=3MHZ	04713	2N4920
A23O8	1853-0037	3	1	TRANSISTOR PNP SI TO-39 PD=1W FT=100MHZ	28480	1853-0037
A23O9	1854-0271	9		TRANSISTOR NPN SI TO-39 PD=1W FT=150MHZ	28480	1854-0271
A23O10	1854-0474	4		TRANSISTOR NPN SI PD=310MW FT=100MHZ	04713	2N5551
A23O11	1853-0080	6		TRANSISTOR PNP SI PD=300MW FT=30MHZ	28480	1853-0080
A23O12	1854-0347	0		TRANSISTOR NPN 2N4923 SI PD=30W FT=3MHZ	04713	2N4923
A23O13	1854-0474	4		TRANSISTOR NPN SI PD=310MW FT=100MHZ	04713	2N5551
A23O14	1853-0080	6		TRANSISTOR PNP SI PD=300MW FT=30MHZ	28480	1853-0080
A23O15	1853-0204	6		TRANSISTOR PNP 2N4920 SI PD=30W FT=3MHZ	04713	2N4920
A23O16	1853-0080	6		TRANSISTOR PNP SI PD=300MW FT=30MHZ	28480	1853-0080
A23O17	1854-0474	4		TRANSISTOR NPN SI PD=310MW FT=100MHZ	04713	2N5551
A23O18	1853-0080	6		TRANSISTOR PNP SI PD=300MW FT=30MHZ	28480	1853-0080
A23O19	1854-0474	4		TRANSISTOR NPN SI PD=310MW FT=100MHZ	04713	2N5551
A23R1	0683-2725	8	2	RESISTOR 2.7K 5% .25W FC TC=400/+700	01121	C82725
A23R2	0683-5625	3		RESISTOR 5.6K 5% .25W FC TC=400/+700	01121	C85625
A23R4	0683-3335	8		RESISTOR 33K 5% .25W FC TC=400/+800	01121	C83335
A23R5	0683-3325	6		RESISTOR 3.3K 5% .25W FC TC=400/+700	01121	C83325
A23R6	0683-1535	6		RESISTOR 15K 5% .25W FC TC=400/+800	01121	C81535
A23R7	0683-2225	3		RESISTOR 2.2K 5% .25W FC TC=400/+700	01121	C82225
A23R8	2100-3274	2		RESISTOR-TRMR 10K 10% C SIDE-ADJ 1-TRN	28480	2100-3274
A23R9	2100-3207	1		RESISTOR-TRMR 5K 10% C SIDE-ADJ 1-TRN	28480	2100-3207
A23R10	0683-4755	8	2	RESISTOR 4.7M 5% .25W FC TC=900/+1100	01121	C84755
A23R10	2100-3274	2		RESISTOR-TRMR 10K 10% C SIDE-ADJ 1-TRN	28480	2100-3274
A23R11	0683-4755	8		RESISTOR 4.7M 5% .25W FC TC=900/+1100	01121	C84755
A23R11	2100-3274	2		RESISTOR-TRMR 10K 10% C SIDE-ADJ 1-TRN	28480	2100-3274
A23R12	0683-3335	8		RESISTOR 33K 5% .25W FC TC=400/+800	01121	C83335
A23R13	0683-1835	9		RESISTOR 18K 5% .25W FC TC=400/+800	01121	C81835
A23R14	0683-2725	8		RESISTOR 2.7K 5% .25W FC TC=400/+700	01121	C82725
A23R15	0683-5625	3		RESISTOR 5.6K 5% .25W FC TC=400/+700	01121	C85625
A23R17	0683-3335	8		RESISTOR 33K 5% .25W FC TC=400/+800	01121	C83335
A23R18	0683-3325	6		RESISTOR 3.3K 5% .25W FC TC=400/+700	01121	C83325
A23R19	0683-1535	6		RESISTOR 15K 5% .25W FC TC=400/+800	01121	C81535
A23R20	0683-2225	3		RESISTOR 2.2K 5% .25W FC TC=400/+700	01121	C82225
A23R22	0757-0464	5	2	RESISTOR 90.9K 1% .125W F TC=0/+100	24546	C4-1/8-T0-9092-F
A23R23	0699-0391	3		RESISTOR 25K 1% .125W F TC=0/+25	28480	0699-0391
A23R24	0699-0391	3		RESISTOR 25K 1% .125W F TC=0/+25	28480	0699-0391
A23R25	0683-4725	2		RESISTOR 4.7K 5% .25W FC TC=400/+700	01121	C84725
A23R26	0698-4486	3	2	RESISTOR 24.9K 1% .125W F TC=0/+100	24546	C4-1/8-T0-2492-F
A23R27	0698-4486	3		RESISTOR 24.9K 1% .125W F TC=0/+100	24546	C4-1/8-T0-2492-F
A23R29	0683-2235	5		RESISTOR 22K 5% .25W FC TC=400/+800	01121	C82235
A23R30	0757-0464	3		RESISTOR 90.9K 1% .125W F TC=0/+100	28480	0757-0464
A23R31	0757-0464	3		RESISTOR 90.9K 1% .125W F TC=0/+100	24546	C4-1/8-T0-9092-F
A23R32	0683-4725	2		RESISTOR 4.7K 5% .25W FC TC=400/+700	01121	C84725
A23R33	0683-1835	9		RESISTOR 18K 5% .25W FC TC=400/+800	01121	C81835
A23R34	0683-1835	9		RESISTOR 18K 5% .25W FC TC=400/+800	01121	C81835
A23R35	0683-3335	8		RESISTOR 33K 5% .25W FC TC=400/+800	01121	C83335
A23R36	0698-3450	9		RESISTOR 42.2K 1% .125W F TC=0/+100	24546	C4-1/8-T0-4222-F
A23R37	0698-3450	9		RESISTOR 42.2K 1% .125W F TC=0/+100	24546	C4-1/8-T0-4222-F
A23R38	0683-4735	4		RESISTOR 47K 5% .25W FC TC=400/+800	01121	C84735
A23R39	0683-1225	1		RESISTOR 1.2K 5% .25W FC TC=400/+700	01121	C81225
A23R40	0683-1235	3		RESISTOR 12K 5% .25W FC TC=400/+800	01121	C81235
A23R41	0683-1525	4		RESISTOR 1.5K 5% .25W FC TC=400/+700	01121	C81525
A23R42	0683-1005	5		RESISTOR 10 5% .25W FC TC=400/+500	01121	C81005

See introduction to this section for ordering information  
\*Indicates factory selected value



Table 6-3. Replaceable Parts (Cont'd).

Reference Designation	HP Part Number	C D	Qty	Description	Mfr Code	Mfr Part Number
A23R43	0683-1005	5		RESISTOR 10 5% .25W FC TC=-400/+500	01121	CB1005
A23R44	0683-1525	4		RESISTOR 1.5K 5% .25W FC TC=-400/+700	01121	CB1525
A23R45	0683-2235	5		RESISTOR 22K 5% .25W FC TC=-400/+800	01121	CB2235
A23R46	0683-2235	5		RESISTOR 22K 5% .25W FC TC=-400/+800	01121	CB2235
A23R47	0683-4735	4		RESISTOR 47K 5% .25W FC TC=-400/+800	01121	CB4735
A23R48	0683-1535	6		RESISTOR 15K 5% .25W FC TC=-400/+800	01121	CB1535
A23R49	0683-1535	6		RESISTOR 15K 5% .25W FC TC=-400/+800	01121	CB1535
A23R50	0683-3335	8		RESISTOR 33K 5% .25W FC TC=-400/+800	01121	CB3335
A23R51	0683-4725	2		RESISTOR 4.7K 5% .25W FC TC=-400/+700	01121	CB4725
A23R52	0683-4735	4		RESISTOR 47K 5% .25W FC TC=-400/+800	01121	CB4735
A23R53	0683-1225	1		RESISTOR 1.2K 5% .25W FC TC=-400/+700	01121	CB1225
A23R54	0683-1235	3		RESISTOR 12K 5% .25W FC TC=-400/+800	01121	CB1235
A23R55	2100-3252	6		RESISTOR-TRMR 5K 10% C TOP-ADJ 1-TRN	28480	2100-3252
A23R56	0683-1225	1		RESISTOR 1.2K 5% .25W FC TC=-400/+700	01121	CB1225
A23R57	0683-3335	8		RESISTOR 33K 5% .25W FC TC=-400/+800	01121	CB3335
A23R58	0683-5615	1		RESISTOR 560 5% .25W FC TC=-400/+600	01121	CB5615
A23R59	0757-0439	4		RESISTOR 6.81K 1% .125W F TC=0+/-100	24546	C4=1/8-T0-6811-F
A23R60	0757-0439	4		RESISTOR 6.81K 1% .125W F TC=0+/-100	24546	C4=1/8-T0-6811-F
A23R61	0683-1835	9		RESISTOR 18K 5% .25W FC TC=-400/+800	01121	CB1835
A23R62	0683-1225	1		RESISTOR 1.2K 5% .25W FC TC=-400/+700	01121	CB1225
A23R63	0683-1015	7		RESISTOR 100 5% .25W FC TC=-400/+500	01121	CB1015
A23R64	0683-1015	7		RESISTOR 100 5% .25W FC TC=-400/+500	01121	CB1015
A23R65	1810-0269	3		NETWORK-RES 9-PIN-SIP .1-PIN-SPCG	28480	1810-0269
A23R66	1810-0269	3		NETWORK-RES 9-PIN-SIP .1-PIN-SPCG	28480	1810-0269
A23R67	1810-0269	3		NETWORK-RES 9-PIN-SIP .1-PIN-SPCG	28480	1810-0269
A23R68	0683-1235	3		RESISTOR 12K 5% .25W FC TC=-400/+800	01121	CB1235
A23R69	0683-5625	3		RESISTOR 5.6K 5% .25W FC TC=-400/+700	01121	CB5625
A23R70	0683-1235	3		RESISTOR 12K 5% .25W FC TC=-400/+800	01121	CB1235
A23R71	0683-1005	5		RESISTOR 10 5% .25W FC TC=-400/+500	01121	CB1005
A23U1	1826-0319	7		OP AMP BIFET T0-99	27014	LF356H
A23U2	1826-0319	7		OP AMP BIFET T0-99	27014	LF356H
A23U3	1826-0319	7		OP AMP BIFET T0-99	27014	LF356H
A23U4	1820-1856	7		CONV 12-B-D/A 24-DIP-C	24355	AD563KD/BCD
A23U5	1826-0122	0		IC 7805 V RGLTR T0-220	07263	7805UC
A23U6	1826-0161	7	3	OP AMP GP QUAD 14-DIP-P	04713	MLM324P
A23U7	1826-0161	7		OP AMP GP QUAD 14-DIP-P	04713	MLM324P
A23U8	1826-0161	7		OP AMP GP QUAD 14-DIP-P	04713	MLM324P
A23U9	1826-0174	2		COMPARATOR GP QUAD 14-DIP-P	28480	1826-0174
A23U10	1820-1730	6		IC FF TTL LS D-TYPE POS-EDGE-TRIG COM	01295	8N74LS273N
A23U11	1820-1730	6		IC FF TTL LS D-TYPE POS-EDGE-TRIG COM	01295	8N74LS273N
A23U12	1826-0319	7		OP AMP BIFET T0-99	27014	LF356H
A23U13	1826-0222	1		OP AMP GP QUAD 14-DIP-P	07263	UA4136PC
A23U14	1820-1197	9		IC GATE TTL LS NAND QUAD 2-INP	01295	8N74LS00N
A23U15	1820-1481	4		IC PIA NMOS	04713	MC6821L
A23U16	1820-2024	3		IC DRVR TTL LS LINE DRVR OCTL	01295	8N74LS244N
A23U17	1820-2024	3		IC DRVR TTL LS LINE DRVR OCTL	01295	8N74LS244N
				A23 MISCELLANEOUS PARTS		
	04274-26523	0		PC BOARD, BLANK	28480	04274-26523
				CHASSIS MOUNTED COMPONENTS		
C1	0160-4259	9	1	CAPACITOR, FXD .22UF +/-10% 250VDCW	C0633	PME271M622
C2	0140-0200	0	4	CAPACITOR-FXD 390PF +/-5% 300VDC MICA	72136	DM15F391J0300WV1CR
C3	0140-0200	0		CAPACITOR-FXD 390PF +/-5% 300VDC MICA	72136	DM15F391J0300WV1CR
C4	0140-0200	0		CAPACITOR-FXD 390PF +/-5% 300VDC MICA	72136	DM15F391J0300WV1CR
C5	0140-0200	0		CAPACITOR-FXD 390PF +/-5% 300VDC MICA	72136	DM15F391J0300WV1CR
C6	0150-0070	3	3	CAPACITOR-FXD .02UF +/-20% 500VDC CER	28480	0150-0070
C7	0150-0070	3		CAPACITOR-FXD .02UF +/-20% 500VDC CER	28480	0150-0070
C8	0150-0070	3		CAPACITOR-FXD .02UF +/-20% 500VDC CER	28480	0150-0070
CR1	1901-0496	1		DIODE-PWR RECT 100V 12A DO-4	04713	MR1121
CR2	1901-0496	1		DIODE-PWR RECT 100V 12A DO-4	04713	MR1121
F1	2110-0305	5	1	FUSE 1.25A 250V SLO-BLO 1.25X.25 UL	75915	3131.25
	2110-0616	5	1	FUSE .6A 250V SLO-BLO 1.25X.25 UL	75915	313.600
FL1	9135-0035	7	1	FILTER-LINE WIRES-TERMS	28480	9135-0035
L1	04274-85008	0	1	COIL ASSEMBLY	28480	04274-85008
Q1	1854-0313	0	1	TRANSISTOR NPN 2N3771 8I T0-3 PD=150W	01928	2N3771
Q2	1854-0063	7	1	TRANSISTOR NPN 2N3055 8I T0-3 PD=115W	28480	1854-0063
Q3	1853-0252	4	2	TRANSISTOR PNP 8I T0-3 PD=150W FT=4MHZ	28480	1853-0252
Q4	1853-0252	4		TRANSISTOR PNP 8I T0-3 PD=150W FT=4MHZ	28480	1853-0252
S2	3101-2298	1	2	SWITCH, SLIDE DPDT-NS	28480	3101-2298
S3	3101-2298	1		SWITCH, SLIDE DPDT-NS	28480	3101-2298

See introduction to this section for ordering information  
\*Indicates factory selected value

Table 6-3. Replaceable Parts (Cont'd).

Reference Designation	HP Part Number	C D	Qty	Description	Mfr Code	Mfr Part Number
*1	04274-61601	0	1	CABLE ASSEMBLY, INPUT(LC) (31 CM)	28480	04274-61601
*2	04274-61602	0	1	CABLE ASSEMBLY, INPUT(LP) (31 CM)	28480	04274-61602
*3	04274-61603	1	1	CABLE ASSEMBLY, INPUT(MC) (43 CM)	28480	04274-61603
*4	04274-61604	2	1	CABLE ASSEMBLY, INPUT (MP) (31 CM)	28480	04274-61604
*5	04274-61605	3	1	CABLE ASSEMBLY, INPUT(A1 THRU A3)(3CM)	28480	04274-61605
*6	04274-61606	4	1	CABLE ASSEMBLY, INPUT(A1 THRU A4)(43CM)	28480	04274-61606
*7	04274-61607	5	1	CABLE ASSEMBLY, INPUT(A1 THRU A4)(43CM)	28480	04274-61607
XF1	2110-0565	9	2	FUSEHOLDER CAP 12A MAX FOR UL	28480	2110-0565
XF1	2110-0565	9	2	FUSEHOLDER CAP 12A MAX FOR UL	28480	2110-0565
MISCELLANEOUS PARTS						
1	5040-7219	8	2	FRONT CAP	28480	5040-7219
2	5060-9805	4	2	HANDLE	28480	5060-9805
3	5060-9943	1	2	SIDE COVER	28480	5060-9943
4	5040-7220	1	2	REAR CAP	28480	5040-7220
5	2680-0172	1	4	SCREW-MACH 10-32 .375-IN-LG 100 DEG	28480	2680-0172
6	3101-2216	3	1	SWITCH-PB DPDT ALING 4A 250VAC	28480	3101-2216
7	0570-0368	2	2	SCREW	28480	0570-0368
8	2190-0225	6	2	WASHER	28480	2190-0225
9	1200-0080	3	4	INSULATOR-DIO ALUMINUM HD-ANDZ	28480	1200-0080
10	3050-0226	2	4	WASHER-FL MTLC NO. 10 .203-IN-ID	28480	3050-0226
11	2740-0003	5	2	NUT-HEX-W/LKWR 10-32-TMD .125-IN-THK	00000	ORDER BY DESCRIPTION
12	1901-0406	1	4	DIODE-PWR RECT 100V 12A DO-4	04713	MR1121
13	9100-0870	5	1	TRANSFORMER	28480	9100-0870
14	1250-0018	2	4	CONTACT-RF CONNECTOR SER N: FEMALE-.093	28480	1250-0018
15	5040-0345	7	6	INSULATOR:CONNECTOR	28480	5040-0345
16	0624-0260	8	8	SCREW-TPG 6-20 .5-IN-LG PAN-HD-PHL STL	00000	ORDER BY DESCRIPTION
17	2190-0020	9	8	WASHER-LK HLCL NO. 5 .126-IN-ID	28480	2190-0020
18	0340-0833	9	4	INSULATOR-XSTR NYLON BLACK	28480	0340-0833
19	0624-0248	2	4	SCREW-TPG 8-32 .75-IN-LG HEX WSHR-HD STL	28480	0624-0248
20	0370-2994	0	1	KNOR	28480	0370-2994
21	2510-0045	8	4	SCREW-MACH 8-32 .375-IN-LG PAN-HD-POZI	00000	ORDER BY DESCRIPTION
22	0360-0270	0	1	TERMINAL-GLDR LUG LK-MTG FOR-#10-SCR	28480	0360-0270
23	3100-1205	6	1	SWITCH-ROTARY	28480	3100-1205
24	0360-1190	5	4	TERMINAL-GLDR LUG PL-MTG FOR-#3/8-SCR	28480	0360-1190
25	2950-0001	8	4	NUT-HEX-DBL-CHAM 3/8-32-TMD .094-IN-THK	00000	ORDER BY DESCRIPTION
26	5020-8806	9	1	REAR FRAME	28480	5020-8806
27	5060-9836	1	1	TOP COVER	28480	5060-9836
28	04274-00617	9	1	PLATE	28480	04274-00617
29	04274-00602	2	2	PLATE SHIELD	28480	04274-00602
30	5040-7202	9	1	TRIM, TOP	28480	5040-7202
31	5020-8805	8	1	FRONT FRAME	28480	5020-8805
32	04274-25002	8	1	WINDOW (FREQ)	28480	04274-25002
33	0370-1097	2	1	KNOB	28480	0370-1097
34	04274-00203	9	1	FRONT PANEL (YMP)	28480	04274-00203
34	04274-00204	0	1	FRONT PANEL (HP)	28480	04274-00204
35	04274-25001	7	2	WINDOW DISP. A,B)	28480	04274-25001
36	7120-1254	1	1	NAMEPLATE .312-IN-WD .54-IN-LG AL	28480	7120-1254
36	7120-0478	9	1	TRADE MARK (YMP)	28480	7120-0478
37	04271-50024	4	4	INSULATOR	28480	04271-50024
38	2950-0035	8	4	NUT-HEX-DBL-CHAM 15/32-32-TMD	00000	ORDER BY DESCRIPTION
39	1510-0038	8	1	BINDING POST ASSY SGL THD-STUD	28480	1510-0038
40	1250-0252	6	4	CONNECTOR-RF BNC FEM SGL-HOLE-RR 50-OHM	28480	1250-0252
41	04271-50025	5	4	INSULATOR	28480	04271-50025
42	5041-0564	4	1	KEY CAP	28480	5041-0564
43	0370-0451	0	2	BEZEL	28480	0370-0451
44	1460-1345	5	2	TILT STAND SST	28480	1460-1345
45	5040-7201	6	4	FOOT(STANDARD)	28480	5040-7201
46	5020-8838	7	4	STRUT	28480	5020-8838
47	04274-40001	9	1	ROD (POWER SWITCH)	28480	04274-40001
48	04274-01202	0	1	ANGLE (POWER SWITCH)	28480	04274-01202
49	04274-40002	0	3	GUIDE (ANGLE)	28480	04274-40002
50	04274-00618	0	3	PLATE, SHIELD	28480	04274-00618
51	04274-00601	1	5	PLATE, SHIELD	28480	04274-00601
52	5060-9848	5	1	BOTTOM COVER	28480	5060-9848
53	04274-00205	0	1	SUB PANEL		
54	04274-60203	0	1	REAR PANEL		

See introduction to this section for ordering information  
\*Indicates factory selected value

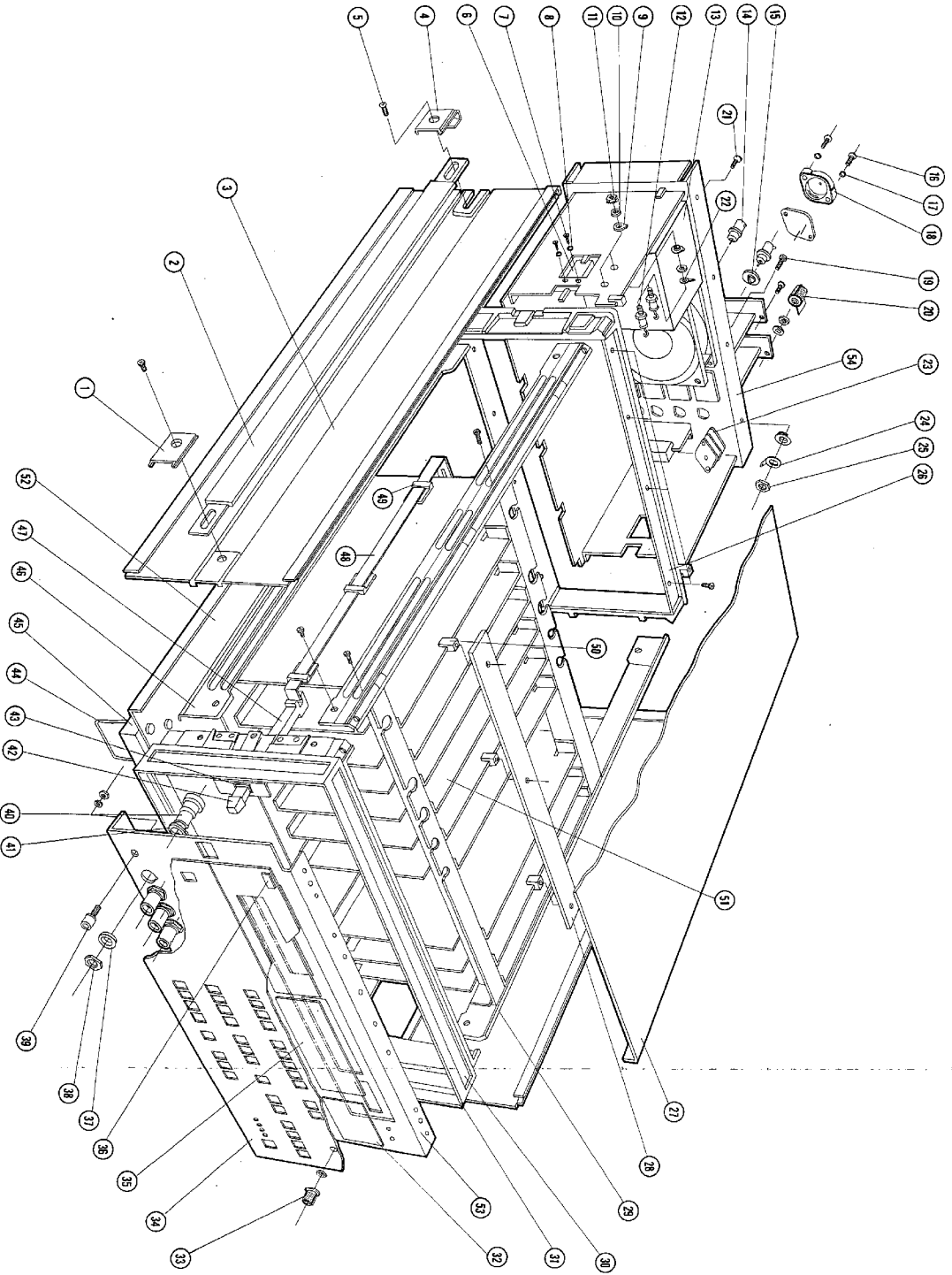

FIGURE 6-1. CABINET PARTS  
6-35

**SECTION VII  
 MANUAL CHANGES**

7-1. INTRODUCTION.

7-2. This section contains information for adapting this manual to instruments to which the contents do not directly apply. The following paragraphs explain how to adapt this manual to apply to other instruments with lower serial prefixes.

7-3. MANUAL CHANGES.

7-4. To adapt this manual to your particular instrument, refer to Table 7-1 and make all of the manual changes listed opposite your instrument serial number. Perform these changes in the sequence listed. Table 7-2 gives a manual changes summary by assembly.

7-5. If your instrument serial number is not listed on the title page of this manual or in Table 7-1 to the right, it may be documented in a yellow MANUAL CHANGES supplement. For additional information about serial number coverage, refer to INSTRUMENT COVERED BY MANUAL in Section I.

Table 7-1. Manual Changes by Serial Numbers.

Serial Prefix or Number	Make Manual Changes
1850J00160 and below	A, B, C, D, E
1850J00235 and below	B, C, D, E
1850J00385 and below	C, D, E
2019J00669 and below	D, E
2019J00760 and below	E

Table 7-2. Summary of Changes by Assembly (Sheet 1 of 2).

CHANGE	Assembly									
	A1	A2	A3	A4	A5	A6	A7	A8	A9	A10
A				C42						
B						C70 U4			U1 U5	
C		CR25 CR26 CR27 CR28								
D										
E									U1 to U10 W7 to W10	



## Section VII

## CHANGE A

Page 6-12, Table 6-3. Replaceable Parts:  
Delete the following part:

A4C42 0160-3456 CAPACITOR-FXD 1000pF +-10% 1000WVDC CERAMIC

## CHANGE B

Page 6-17, Table 6-3. Replaceable Parts:  
Delete the following part:

A6C70 0160-2266 CAPACITOR-FXD 24pF

Page 6-19, Table 6-3. Replaceable Parts:  
Change the part number and description for A6U4 to read:

A6U4 1826-0319 OP AMP BIFET T0-99

Page 6-22, Table 6-3. Replaceable Parts, A9U1 and U5:  
Change the part number for A9U1 and U5 to read:

A9U1 04274-85021  
A9U5 04274-85015

## NOTE

These instruments below were installed with 04274-85031  
and 04274-85025.

1850J-00208  
00211  
00213  
00215  
00216  
00217  
00218  
00219  
00221  
00222  
00231

04274-85021 (old U1) cannot be used with 04274-85025  
(new U5). Also, 04274-85015 (old U5) cannot be utilized  
with 04274-85031 (new U1).

## CHANGE C

Page 6-7, Table 6-3. Replaceable Parts:  
Delete the following parts:

A2CR25 to 28 1901-0040 DIODE-SWITCHING

Page 8-53, Figure 8-29. A3 Component Locations:  
Partially change the diagram as follows:

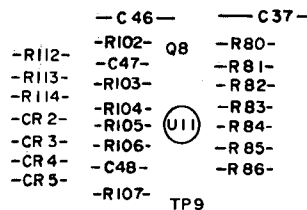

Figure 8-29. A2 Component Locations.

CHANGE D

Page 6-25, Table 6-3. Replaceable Parts, A11:  
Change the part number for A11 Power Supply Board Ass'y to read:

04274-66511

Page 6-27, Table 6-3. Replaceable Parts:  
Change the part number for A12 Mother Board Ass'y to read:

04274-66512

Change the part number for A12XA1L to 22R to read:

XA1L to 9R 1251-1887  
XA11L and 11R 1251-4189  
XA21L to 22R 1251-1887

NOTE

The A11 board with P/N 04274-66511 and that with P/N 04274-66551 use different 15 pin connectors. The same is also true for A12 boards: 04274-66512 and 04274-66552.

CHANGE E

Page 6-21, Table 6-3. Replaceable Parts:  
Change the part number for A9 MPR Board Ass'y (STANDARD) to read:

04274-66513

Page 6-22, Table 6-3. Replaceable Parts:  
Add the following parts:

A9U2 04274-85022 IC, PROM, PROGRAMMED  
A9U4 04274-85014 IC, PROM, PROGRAMMED  
A9U6 04274-85016 IC, PROM, PROGRAMMED  
A9U8 04274-85018 IC, PROM, PROGRAMMED

Change the part numbers and descriptions for A9U1/U3/U5/U7/U10 to read:

A9U1 04274-85031 IC, PROM, PROGRAMMED  
A9U3 04274-85013 IC, PROM, PROGRAMMED  
A9U5 04274-85025 IC, PROM, PROGRAMMED  
A9U7 04274-85017 IC, PROM, PROGRAMMED  
A9U10 04274-85019 IC, PROM, PROGRAMMED



Section VII

Page 6-23, Table 6-3. Replaceable Parts:  
Add the following parts:

A9W7 to W10 8159-0005 WIRE 22AWG W PVC 1 X 22 80C

Page 8-38 and 8-66, signatures table:  
Change the table as follows:

This table can be used to check signatures at A9U1 thru A9U10 ROM's. Signature test point is established at input of Data Buffer (pins 8 thru 6 of A9U31 and A9U32) instead of the respective ROM outputs (A9U1 thru A9U10). This signature list can be used for units with its serial number suffixes of -00266 and above.

For other instruments whose serial number suffixes are earlier than 00266, check that unstable signature display appears or that output states of these ROM's pull up and pull down. If you find above states active in earlier instruments, the program contents in these ROM may be alive.

TEST PIN NO		DSA NAME									
		DSA-12	DSA-14	DSA-15	DSA-16	DSA-17	DSA-18	DSA-19	DSA-20	DSA-21	DSA-13
SIGNAL NAME	ROM NO. TEST POINT	A9U1 A9U8	A9U1 A9U2	A9U3 A9U4	A9U5 A9U6	A9U7 A9U8	A9U1	A9U3	A9U5	A9U7	A9U10
		WINDOW(+5V)	U1 pin-24	755U	P254	P254	P254	P254	826P	826P	826P
DB0	U31 pin-3	9H5F	853H	7994	264C	H3AF	H084	1FFU	4840	00AC	UUPA
DB1	pin-4	U25A	A0AH	307F	08CA	86P3	UUOF	H20P	63UF	69F4	HAUH
DB2	pin-5	FU97	57U9	HPF4	9FBF	7HPC	A41A	7303	CP67	FA15	A63F
DB3	pin-6	1811	H926	379A	CPIU	5H2H	6927	23FF	9587	2110	3094
DB4	U32 pin-3	PFFC	C6U0	2U43	5H23	5A01	A0FP	3987	F598	4HCH	565C
DB5	pin-4	C77P	2562	5410	U899	H1F5	6824	HF08	UF80	F389	501H
DB6	pin-5	C16C	AF61	69HH	89PP	775H	FF7P	U888	521H	A092	39A1
DB7	pin-6	291U	56PC	0P76	FP5F	8PC7	UA7H	A33H	5H5C	AU4F	F454

Page 8-66, Signature Connections tables:  
Change the tables for DSA-12, DSA-14, DSA-15, DSA-16 and DSA-17 as follows:





Signature Connections Window (+5V) : 755U

DSA NO	START	STOP	CLOCK	A9 DSA-SW
DSA-12 NOP (U1-U8)				OFF  ON





Signature Connections Window (+5V) : 254P

DSA NO	START	STOP	CLOCK	A9 DSA-SW
DSA-14 NOP (U1,2)				OFF  ON





Signature Connections Window (+5V) : 254P

DSA NO	START	STOP	CLOCK	A9 DSA-SW
DSA-15 NOP (U3,4)				

Signature Connections Window (+5V) : 254P





DSA NO	START	STOP	CLOCK	A9 DSA-SW
DSA-16 NOP (U5,6)				

Signature Connections Window (+5V) : 254P





DSA NO	START	STOP	CLOCK	A9 DSA-SW
DSA-17 NOP (U7,8)				

Add the following tables for DSA-18, DSA-19, DSA-20 and DSA-21:



Signature Connections Window (+5V) : 826P

DSA NO	START	STOP	CLOCK	A9 DSA-SW
DSA-18 NOP (U1)				



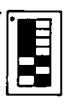

Signature Connections Window (+5V) : 826P

DSA NO	START	STOP	CLOCK	A9 DSA-SW
DSA-19 NOP (U3)				

Signature Connections Window (+5V) : 826P

DSA NO	START	STOP	CLOCK	A9 DSA-SW
DSA-20 NOP (U5)				

Signature Connections Window (+5V) : 826P

DSA NO	START	STOP	CLOCK	A9 DSA-SW
DSA-21 NOP (U7)				

Section VII

Page 8-67, Figure 8-47. A9 Component Locations:  
Partially change the diagram as follows:

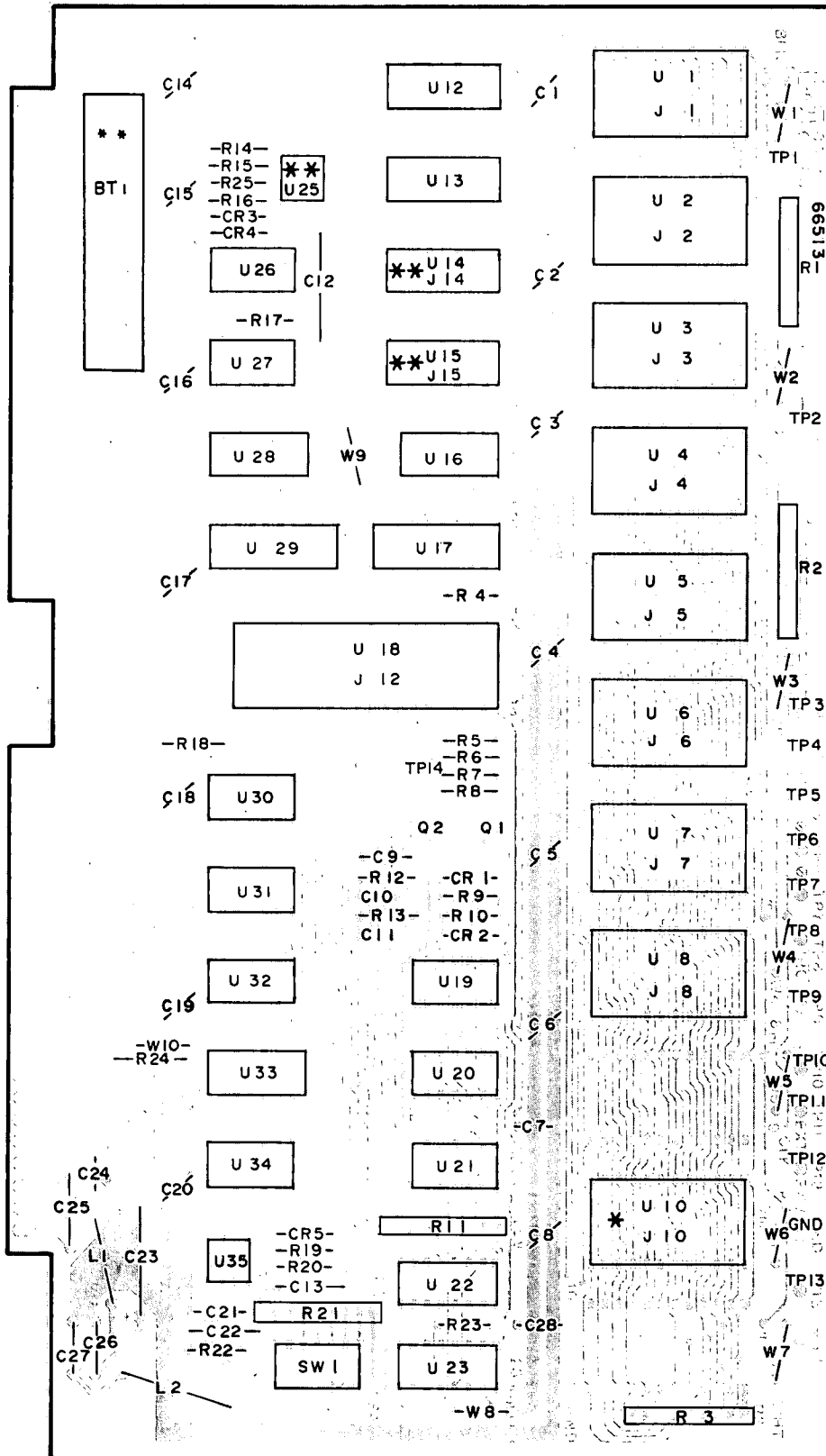

\*\* U10... ONLY FOR OPT 101  
 \*\* U14, 15, 25, BT1, ... ONLY FOR OPT 003

Figure 8-47. A9 Component Locations.

## SECTION VIII

### SERVICE

#### 8-1. INTRODUCTION

8-2. This manual section provides the information and instructions required for servicing the HP Model 4274A MULTI FREQUENCY LCR Meter. Included are Theory of Operation and Troubleshooting Guide with Circuit Schematics. The Theory of Operation describes fundamental principles and circuit operating theory of the 4274A with block diagrams. Circuit schematics, locator illustrations, troubleshooting guide, and other technical data necessary for repairs are integrated into the service sheet foldouts. An illustration of the instrument interior is shown in Figure 8-13.

#### Note

When the instrument circuitry includes expanded capabilities provided by optional equipment, refer to paragraphs entitled OPTIONS for specific option service information.

#### WARNING

TRUBLESHOOTING AND REPAIR ARE ALLOWED FOR QUALIFIED TECHNICAL PERSONNEL ONLY. IF YOUR INSTRUMENT FAILS, REFER INSTRUMENT TO SERVICE PERSONNEL. H-P SERVICE OFFICES OFFER YOU THE BEST ANSWER TO YOUR PROBLEM. A GUIDE TO YOUR LOCAL H-P SERVICE OFFICES MAY BE FOUND ON THE BACK COVER OF THIS MANUAL.

#### 8-3. THEORY OF OPERATION.

8-4. This theory of operation has been organized into three sections: basic theory, a block diagram discussion, and circuit analysis. The basic theory, beginning with paragraph 8-11, explains the concepts and fundamental theory of the 4274A instrument technique adapted for accurately measuring the DUT and for fully achieving automated measurement performance. The block diagram discussion describes the overall circuit operating theory of the 4274A with block-to-block signal flow. Included are block and timing diagrams. The circuit analysis provides a detailed description of how the circuit on

each board functions. For reference convenience, when servicing the instrument, a circuit description is included in the service sheets.

#### 8-5. TROUBLESHOOTING.

8-6. This troubleshooting guide provides instructions and information for locating a faulty circuit instrument component that requires service. All instructions consider the safety of service personnel who will perform the procedures. These diagnostic guides are in the form of step-by-step procedures with flow diagrams. The board level troubleshooting diagrams are the procedures for isolating the problem to an individual malfunctioning circuit board assembly. The guides for locating a defective component are given on the individual board service sheets and integrate service support data -- test point locations, waveform illustrations, voltage data, timing diagrams, and other technical information in addition to providing schematic diagrams for each board.

#### 8-7. RECOMMENDED TEST EQUIPMENT.

8-8. The test equipment required to perform operations outlined in this section is listed in Table 4-1. The table includes: type of instrument required, critical specifications, use, and recommended model. If the recommended model is not available, equipment which meets or exceeds critical specifications listed may be substituted.

#### 8-9. REPAIR.

8-10. Repair explanations tell how to replace defective circuit components. The recommended replacement procedures for components and parts which require special repair, replacement tools, or test equipment should be observed. Correct disassembly and the exchange procedures for such special parts are outlined in Paragraphs 8-44. To prevent damage from improper repair procedure, refer to the appropriate manual section before proceeding with repair.

8-11. BASIC THEORY.

8-12. The HP Model 4274A is comprised of three major circuit sections: the TRD (Transducer), VRD (Vector Ratio Detector) and the microprocessor - centered control blocks as shown in Figure 8-1.

The TRD, mainly consists of the bridge circuit and forms the four terminal pair measurement configuration. A multifrequency signal from the oscillator flows through the DUT (Device Under Test) connected to the unknown terminal and the internal range resistor. When the currents flowing in both the DUT and the RR (range resistor) are mutually equal (bridge section is balanced), the  $e_{DUT}$  and  $e_{ERR}$  factors are transferred to the VRD section.

The VRD alternately receives  $e_{DUT}$  and  $e_{ERR}$ , amplifies (or attenuates) and detects the real ( $0^\circ$  part) and the imaginary ( $90^\circ$  part) components for respective  $e_{DUT}$  and  $e_{ERR}$  by circuitry synchronously controlled from a control section.

These detected signals are applied to the integrator and converted to digital signals for displaying on a counter employing the popular dual slope technique used in Digital Voltmeters.

The control section has a microprocessor as its CPU (central processor unit) and the various software needed for controlling the digital and analog circuits are memorized in a ROM (Read Only Memory).

8-13. TRANSDUCER (TRD).

8-14. The TRD is composed of three board assemblies A1: Range Resistor and Null Detector assembly, A2: Modulator assembly and A3: Power amplifier assembly. Its function and purposes are to apply a consistent test signal to the DUT and to transfer its voltage drop ( $e_{DUT}$ ) to VRD section as well as to cause the same current (as DUT current) to flow through the internal range resistor and in like manner, to transfer the range resistor voltage drop ( $e_{ERR}$ ) to the VRD section.

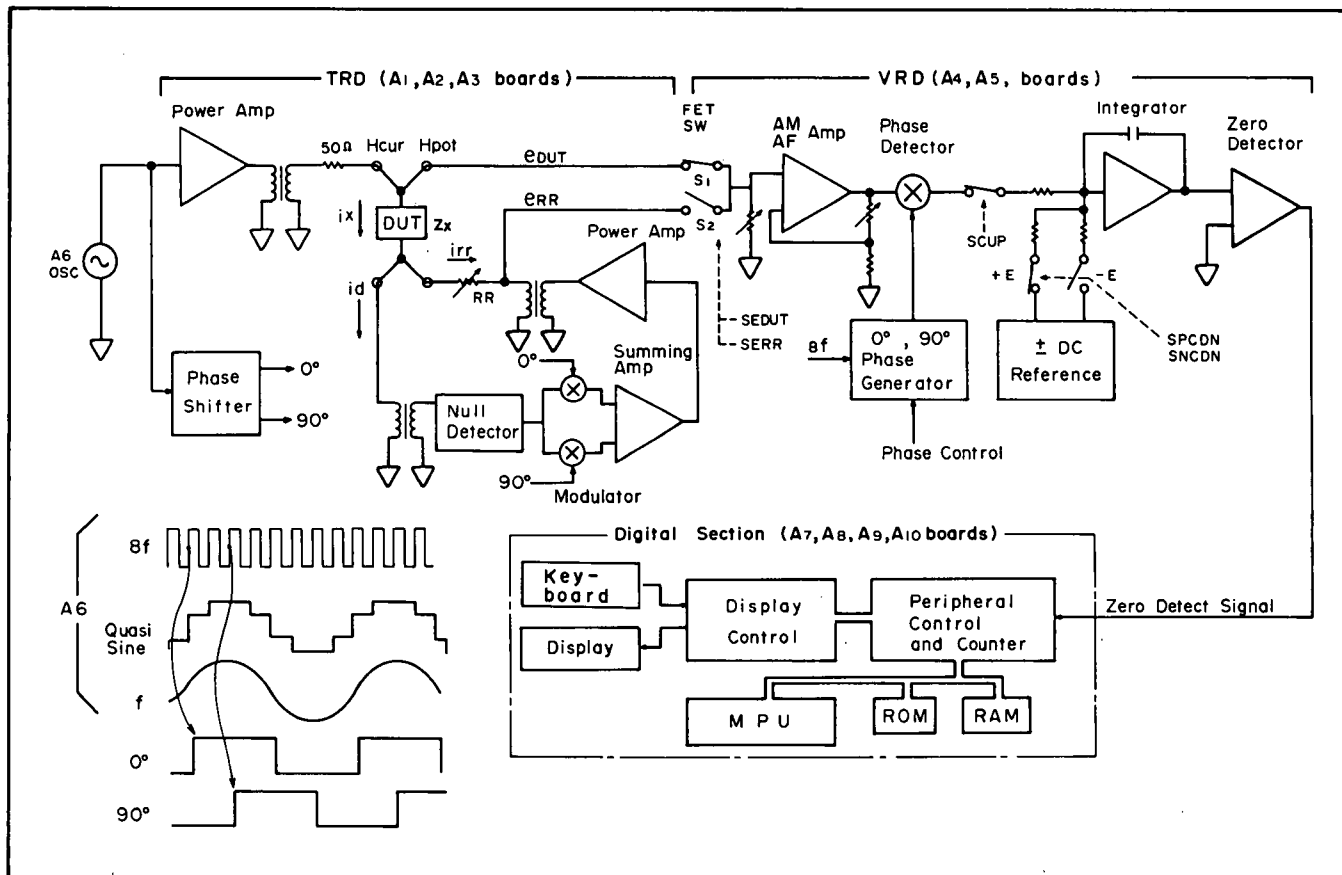

Figure 8-1. Basic Block Diagram.

Power amplifier (A3) receives a 100Hz to 100kHz test signal at a constant level (programmably formed and automatically level controlled in the A6 oscillator). For the various DUT measurements at the desired test levels, the power amplifier attenuates or amplifies the test signal and presents a signal at 1mVrms to 5Vrms to the DUT.

The output impedance of the power amplifier is approximately 50Ω so the test signal is always offered through a 50Ω output impedance. Since this 50Ω impedance is constant regardless of the DUT connected to the unknown terminals, a theoretically constant current flows through the DUT on DUT ranges whose impedance is less than 50Ω. On the other hand, a constant voltage is applied to DUT's on ranges whose DUT impedances are greater than 50Ω. See curves in figure 8-2.

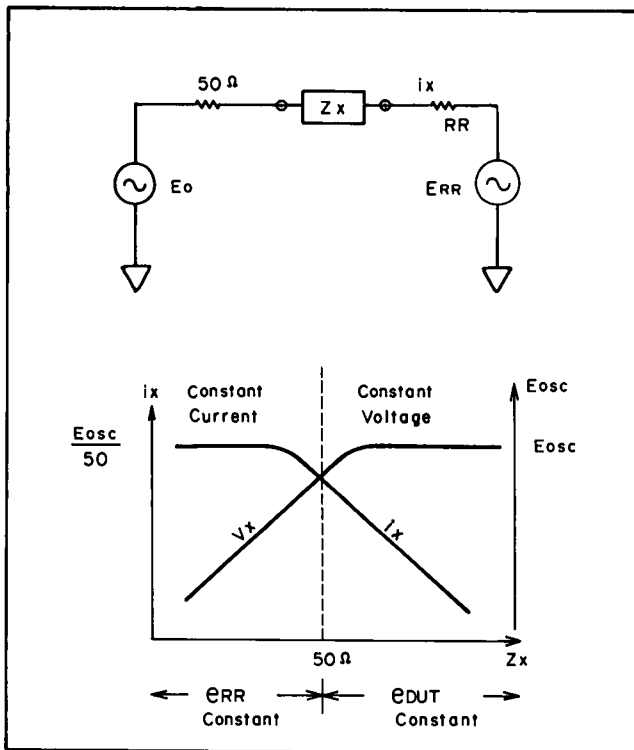

Figure 8-2. Relationship of DUT Impedance and Source Impedance.

For practical measurements, the boundary of the impedance and admittance measurement range is between the 100 and 1000 ranges. For ranges of 100Ω and less, an impedance measurement may be represented by the following formula:

$$e_{DUT} = i_x \cdot Z_x \quad Z_x = \frac{e_{DUT}}{i_x}$$

$$e_{ERR} = i_R \cdot R_R \quad i_R = \frac{e_{ERR}}{R_R}$$

When the bridge is balanced ( $i_x = i_R$  bridge section principles are described in paragraph 8-15).

$$Z_x = \frac{e_{DUT}}{e_{ERR}/R_R} = R_R \cdot \frac{e_{DUT}}{e_{ERR}}$$

For ranges of 1000Ω and higher, the admittance measurement can be represented by the following formulas:

$$e_{DUT} = i_x \cdot \frac{1}{Y_x} \quad Y_x = \frac{i_x}{e_{DUT}}$$

$$e_{ERR} = i_R \cdot \frac{1}{Y_R} \quad i_R = \frac{e_{ERR} \cdot Y_R}{1} = e_{ERR} \cdot \frac{1}{R_R}$$

When the bridge is balanced,  $i_x = i_R$

$$Y_x = \frac{i_x}{e_{DUT}} = \frac{e_{ERR}}{e_{DUT}} \cdot Y_R = \frac{e_{ERR}}{e_{DUT}} \cdot \frac{1}{R_R}$$

These two measurement concepts cover the wide measurement range functions for capacitance, inductance, resistance and impedance.

The test signal with its level appropriately controlled by the A3 power amplifier, is applied to the DUT. For impedance range measurement techniques, the constant current ( $i_x$ ) flows through the DUT and its voltage drop ( $e_{DUT}$ ) depends on the impedance of the DUT. For the admittance range measurement, the constant voltage ( $V_x$ ) is applied to the DUT. Thus  $e_{DUT}$  is constant and  $e_{ERR}$  depends on the impedance of the DUT.

8-15. Bridge section.

The term showing that the bridge section is balanced is quite simple:

Here the current ( $i_x$ ) flowing through the DUT is equal to the current ( $i_{RR}$ ) flowing through the range resistor.

When the bridge section is unbalanced, an unbalance current ( $i_d$ ) is generated and flows into the Lpot terminal.  $i_d$  is converted into an unbalance voltage which is passed to a 0° and 90° phase detector for detecting DC voltage proportional to the unbalance voltage.

These DC voltages charge an integrator and their outputs, respectively, modulate the AC signal of both phase components real (0°) and imaginary (90°). The (0° and 90°)

modulated signals are added in a summing amplifier and fed back to the range resistor so that current ( $i_{rr}$ ) becomes equal to current ( $i_x$ ) and does so until an unbalanced current ( $i_d$ ) doesn't exist at the input of the Null Detector.

This balancing continues until the unbalance current reaches zero. While the bridge is in unbalanced condition, an UNBAL signal is continuously sent to the control section to announce that the measurement is not ready to be displayed. The bridge section is balanced by switching range resistors, selecting the appropriate measurement range, and by controlling the attenuation and gain. When the bridge is balanced  $e_{DUT}$  and  $e_{ERR}$  are alternately sent to the measurement section (VRD) and the instrument is ready to measure and count.

8-16. Range Resistor and Gain Selections. There is a complex relationship in the 4274A between the range resistor used and the range of the respective function (L,C, and R). In addition, the frequency range must be known to determine the range resistor to be used. These relationships are summarized in Table 8-A of Figure 8-5.

8-17. Bridge Balance Response Time. The response time for balancing the bridge is typically less than 25msec at test frequencies lower than 400Hz and less than 10msec at 400Hz and higher test frequencies. Response time is affected by the loop gain ( $k$ ) and the phase shift ( $\theta$ ) in the bridge circuitry. Consequently, if the current flowing through the DUT is momentarily changed, a resultant unbalanced voltage ( $E_d$ ) is generated (and it no longer equals zero volts).

As described in paragraph 8-15, the balancing procedure operates to bring  $E_d$  towards 0 volts.  $E_d$  variations can be represented by the following formula:

$$E_d \propto e^{-k(\cos \theta) t}$$

- $k$ : loop gain
- $\theta$ : phase shift between modulator output (I-V converter) and phase detector

Loop gain is maintained constant by the gain amplifier and gain normalizer on the A1 board so as to maintain a consistent response time for dynamic test signal levels. A phase tracking circuit is used to compensate for any phase shift in the A2 phase detector.

8-18. VOLTAGE RATIO DETECTOR.

8-19. The VRD (Vector Ratio Detector) is composed of two board assemblies: A4 Process amplifier and A5 A-D converter assembly. Principal functions of this section are to:

1. Convert two AC voltages ( $e_{DUT}$  and  $e_{ERR}$ ) detected by the TRD to real ( $0^\circ$ ) and imaginary ( $90^\circ$ ) vector components, respectively.
2. To output four (4) components to the A-D converter in which the dual slope technique is employed and to transfer the equivalent time data information to the digital section.

The VRD section receives  $e_{DUT}$  and  $e_{ERR}$  information from the TRD section. These two voltages are periodically passed to the AM/AF amplifier through the buffer amplifier and FET switches (S1 and S2) which are operated by control signals (SEDUT and SERR) sent from A5 Latch.  $e_{DUT}$  and  $e_{ERR}$  are attenuated or amplified by the AM/AF amplifiers to an appropriate amplitude and fed to the phase detector. The Phase Detector is sequentially switched by square waves whose phase shifts are respectively  $0^\circ$  and  $90^\circ$  as referenced to the test signal.

$e_{DUT}$  and  $e_{ERR}$  are chopped and converted to rectangular components whose magnitudes are proportional to the real ( $0^\circ$ ) and the imaginary ( $90^\circ$ ) parts of both  $e_{DUT}$  and  $e_{ERR}$  by the phase detector. Thus, four components ( $0^\circ$  part of  $e_{DUT}$ ,  $0^\circ$  part of  $e_{ERR}$ ,  $90^\circ$  part of  $e_{DUT}$  and  $90^\circ$  part of  $e_{ERR}$ ) are detected by the phase detector circuit. The individual phase components are serially integrated for about 10mS and discharged by the dual slope A-D converter (an integrator with plus/minus DC reference voltage sources) to obtain time periods which are exactly proportional to the amplitudes of each of the four components as shown in Figure 8-3.

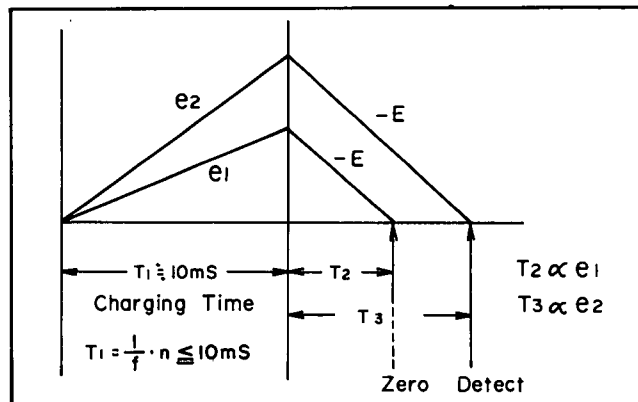

Figure 8-3. A-D Conversion.

This time data is transferred to the data counter in the digital section. Internal clock pulses are counted for these durations (which are proportional to the respective components) and a vector ratio is calculated by arithmetical manipulation in the digital section for each of the functions controlled from the front panel (display-A and display-B).

#### 8-20. CONTROL SECTION

8-21. The analog section of the 4274A is controlled by a microprocessor (MPU)-centered control section which governs the various sequences required to perform the desired measurement and the self diagnostic tests. Range control, selection of the measurement mode, timing and processing of the VRD section, and the complex management of the matrix for appropriate gain selections, and the numerical computation for displaying the measurement results are manipulated through the peripheral interface adapter (PIA) by the MPU which is used for control and computation purposes. These controls are done by interrupting the MPU and address to the memory which stores the necessary management instructions for both the analog and the digital sections. The 16 bit address bus allows the MPU to address up to 64K memory locations. The data bus is 8 bits wide and is bidirectional for reading and writing the desired data to and from the MPU.

All the functions set at the front panel keyboard are decoded in the display control board. All keyboard switches are assigned individual addresses to facilitate recognizing and setting the chosen function.

When a control key is depressed, a key input detector in the display control identifies the new key data and sends it to the peripheral control board (A7) via the data bus. The PIA sends an interrupt signal to the MPU asking it to provide up-dated instructions. The MPU recognizes the new address and fetches the necessary program from the addressed ROM, sends new data to display section and new instructions to both the analog latches and the digital boards. Display control (A8) converts the measurement data signals from MPU to display component signals which are coded such that the corresponding numeric figures are displayed on the 7 segment LED displays. The measurement data is momentarily stored in a memory in this section and sent to the matrix drive of each display on display board (A10).

8-22. The peripheral control includes a peripheral interface adapter (PIA) which provides a universal means for interfacing peripheral equipment to the MPU through two 8 bit bidirectional peripheral data buses. Its function is programmed by the MPU. The PIA has four (4) control lines and no external logic is required to communicate with other peripherals. This capability is useful for interfacing with the HP-IB compatible interface (option 101) or with the DC bias control boards (options 001 or 002). The data from the MPU is translated into the various control signals which set the FET switches in the analog section for measuring the desired signal under the appropriate conditions. This board also includes the counter which counts the internal 10MHz clock pulses for the period transferred from the A-D converter (A5).



Concept of Vector Voltage Ratio Measurement:

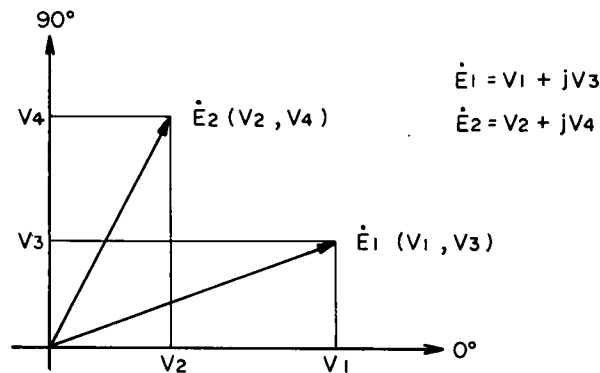

For the explanation of this technique, E1 and E2 are used instead of eDUT and eRR. E1 is divided into V1 (0° component) and V3 (90° component) by the 0° and 90° gates of the phase detector. In like manner, E2 is divided into V2 (0° component) and V4 (90° component). Thus E1 and E2 can be represented by the formulas:

$$E_1 = V_1 + jV_3 \quad E_2 = V_2 + jV_4 \dots\dots\dots (1)$$

The desired impedances or admittances are given by the following equations:

$$Z_x = \frac{E_1}{E_2} \cdot RR \quad \text{or} \quad Y_x = \frac{E_2}{E_1} \cdot \frac{1}{RR} \dots\dots\dots (2)$$

(Where RR is the Range Resistance).

Since the value of RR is known, the ratio of E1 and E2 ( $\frac{E_2}{E_1}$  or  $\frac{E_1}{E_2}$ ) can be used to calculate the unknown value of the DUT in admittance or impedance measurements. As RR is a constant value for one measurement cycle,  $\frac{E_2}{E_1}$  can be represented as:

$$\frac{E_2}{E_1} = x + jy \dots\dots\dots (3)$$

$$x + jy = \frac{V_2 + jV_4}{V_1 + jV_3} = \frac{V_1V_2 + V_3V_4 + j(V_1V_4 - V_2V_3)}{V_1^2 + V_3^2} \dots\dots (4)$$

$$x = \frac{V_1V_2 + V_3V_4}{V_1^2 + V_3^2} \dots\dots\dots (5)$$

$$y = \frac{V_1V_4 - V_2V_3}{V_1^2 + V_3^2} \dots\dots\dots (6)$$

Thus, the real and imaginary components of the DUT can be calculated by the above equations once the values V1, V2, V3 and V4 have been determined.

The real parts (V1, V2) of E1 and E2 are first measured and then the imaginary parts (V3, V4) are next measured in the VRD section. To enable constant production of the values V1 thru V4, the A-D converter continuously transfers the required four (4) pieces of time data information to the digital section.

The real part (V1) of E1 is detected in the phase detector in the following manner: the integrator is charged during time TC ( about 10 msec). Just after the 10 msec charge time, the integrator is discharged by either the plus or minus DC reference voltage towards zero volts until the zero volt level is crossed. As soon as the discharge crosses the DC zero volt level, a zero comparator sends a pulse indicating completion of the discharge cycle and simultaneously transfers the time data (T1: discharging time) to the digital section.

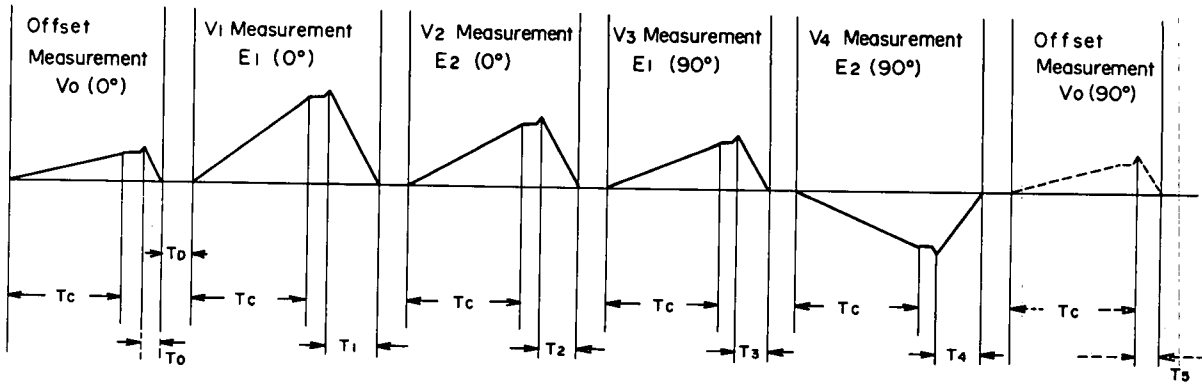

Tc : Charging Time  
Td : Data Transfer and Integrator Reset  
T1 thru T4 : Discharge Time ∝ Vo thru V4

The digital section accepts the time data and stores it in its memory. It now resets the control logic for the next conversion cycle (V2 conversion to T2). Again, and in like manner, four components (V1 thru V4) are translated into time data (T1 thru T4) and serially transferred to the digital section.

Since these four (4) pieces of time data (T1 thru T4) are exactly proportional to the amplitude of the four components (V1 thru V4), V1 thru V4 can be given by the following equations:

$$\left. \begin{aligned} V1 &= K \cdot TC \cdot E \cdot T1 \\ V2 &= K \cdot TC \cdot E \cdot T2 \\ V3 &= K \cdot TC \cdot E \cdot T3 \\ V4 &= K \cdot TC \cdot E \cdot T4 \end{aligned} \right\} \dots \dots \dots (7)$$

Note: K = (Amplifier gain) x (Efficiency of phase detector) x (Integration Constant).

K · TC · E is a constant value for one measurement cycle.

Consequently, equations (5) and (6) can be rearranged to produce:

$$X = \frac{T1 \cdot T2 + T3 \cdot T4}{T1^2 + T3^2} \dots \dots \dots (8)$$

$$Y = \frac{T1 \cdot T4 - T2 \cdot T3}{T1^2 + T3^2} \dots \dots \dots (9)$$

The digital section arithmetically calculates the result of the above equations by fetching and using the time data (T1 thru T4) from its memory as necessary.

Figure 8-4. Concept of Vector Ratio Measurement (Sheet 2 of 4).

In an actual measurement cycle, two additional measurements are made to compensate for any residual offset existing in the circuits behind the phase detector. To accomplish this compensation, 0° and 90° components of the offset magnitude (V0) are respectively measured to obtain the proportional times (T0 and T5) (on the condition with that the input of the phase detector is shorted). To is, respectively, subtracted from both T1, T2 and T5 is, respectively, subtracted from both T3 and T4.

However, since it is substantially known that T0 is equal to T5 at frequencies lower than 10KHz, X and Y can be given by the following equations:

$$X = \frac{(T1 - T0)(T2 - T0) + (T3 - T0)(T4 - T0)}{(T1 - T0)^2 + (T3 - T0)^2} \dots\dots (10)$$

$$Y = \frac{(T1 - T0)(T4 - T0) - (T2 - T0)(T3 - T0)}{(T1 - T0)^2 + (T3 - T0)^2} \dots\dots (11)$$

VRD Multiplier:

AM amplifier includes accurate attenuators (1/1, 1/10 and 1/100) in the VRD section as shown in Figure 8-A so the measurable ranges can be expanded (in addition to the five ranges determined by the five range resistors in the TRD section).

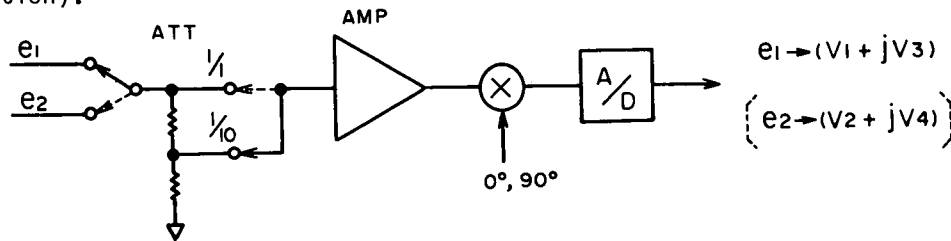

To measure the e1 signal, the attenuator is switched to its 1/10 position enabling the measurement of V1 and V3. On the next measurement cycle (to measure e2) the attenuator is switched to its 1/1 (through) position and V2 and V4 are measured. See above figure.

$$\frac{V1}{10} = K \cdot TC \cdot E \cdot T1 \quad \frac{V3}{10} = K \cdot TC \cdot E \cdot T3 \dots\dots\dots (12)$$

$$V2 = K \cdot TC \cdot E \cdot T1 \quad V4 = K \cdot TC \cdot E \cdot T4 \dots\dots\dots (13)$$

Therefore,

$$X = 10 \cdot \frac{T1 \cdot T2 + T3 \cdot T4}{T1^2 + T3^2} \quad Y = 10 \cdot \frac{T1 \cdot T4 - T2 \cdot T3}{T1^2 + T3^2} \dots\dots (14)$$

Consequently, a voltage ratio with a magnitude of ten (10) times can be obtained. Also, three (3) attenuations (1/1, 1/2 and 1/4) are established in the AF amplifier of the VRD section to compensate for the frequency characteristics ( $\omega C$  or  $\omega L$ ) of one decade frequency range (i.e: 250Hz thru 2.5KHz) when capacitors or inductors are measured. These actions improve the signal-to-noise (S/N) ratio.

Figure 8-4. Concept of Vector Ratio Measurement (Sheet 3 of 4).

Test Level Measurement:

The VRD section is designed so that the voltages applied to the DUT can be measured. For this measurement, a similar vector voltage ratio measurement technique is employed. See figure below.

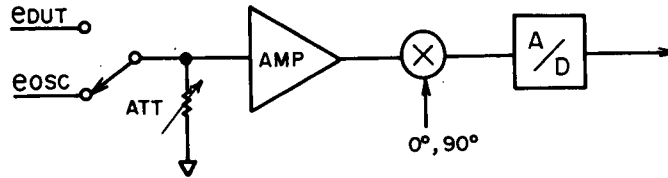

AC signals of known amplitude (10 mVrms), and of the same frequency as the test frequency, are measured instead of e<sub>ERR</sub> and their absolute values compared and calculated by the following equations:

$$\frac{\dot{e}_{DUT}}{\dot{e}_{OSC}} = X + jy \dots\dots\dots (15)$$

$$|\dot{e}_{DUT}| = \sqrt{X^2 + y^2} \cdot |\dot{e}_{OSC}| \dots\dots\dots (16)$$

To calculate the current through the DUT, the following equations are used:

$$e_{ERR} = iX \cdot RR \dots\dots\dots (17)$$

e<sub>ERR</sub> is the absolute value resulting from:

$$|e_{ERR}| = \sqrt{X^2 + y^2} |\dot{e}_{OSC}| \dots\dots\dots (18)$$

Hence,

$$iX = \frac{e_{ERR}}{RR} = \frac{|\dot{e}_{OSC}|}{RR} \cdot \sqrt{X^2 + y^2} \dots\dots\dots (19)$$

Figure 8-4. Concept of Vector Ratio Measurement (Sheet 4 of 4).

RANGE RESISTOR and GAIN SELECTIONS.

Table 8-A can be used to determine which range resistor is being used under a given set of conditions.

There are five (5) range resistors which differ decade step and are so accurate. As described in paragraph 3-14 on page 3-10, the 9 basic ranges (Z1 - Z4, Y1 - Y5) cover 13 virtual ranges depending on the values of the measured parameters and the test frequencies set. In Table 8-A, Z indicates the ranges on which impedance measurements are performed and Y indicates the ranges on which admittance measurements are performed.

It is theoretically possible to equip the instrument with 9 separate range resistors. However, it's substantially difficult to use them while maintaining both precise resistance accuracy and negligible phase shift over a wide frequency range. Therefore, the other four (virtually eight) ranges are arithmetically constructed by a combination of amplifier gains (AM: x1, AM: x10, AM: x100, AG: x1, AG: 2, AG: 10, AG: 20 and AG: 100).

To determine the range resistor employed, use the table. For example, if the 100nF range is selected with a test frequency of 1.0kHz, follow the frequency (250Hz - 2.5kHz) line to the 100nF range (Y-4) column and go the bottom of the table where the range resistors are listed to find 100Ω (OSC MULTIPLIER: x5) and 1kΩ (OSC MULTIPLIER: except for x5).

Therefore, Table 8-A can be used to roughly isolate an inappropriate range resistor selection or whose value has shifted from original design value.

AM and AG are unique abbreviations for describing the gain condition of AM Amplifier in the A4 Process Amplifier.

AM means amplifier multiplier, and in effect, represents the condition of the attenuator (1, 1/10 or 1/100) in the amplifier.

To indicate which attenuator is activated, AM x 1, AM x 10 or AM x 100 should be translated as follows: AM x 1 indicates that the 1/100 attenuator is activated and operates with the amplifier, AM x 100 indicates that 1/1 attenuator is activated, etc.

To achieve the appropriate gain required for various DUT's, the AM amplifier is controlled in five degrees of AG (amplifier gain: x1, x2, x10, x20 and x100). The unit here is not dB.

In an actual measurement, the five range resistors, three of the ten decade step attenuators and the five operational gains are combined as required to produce an appropriate measurements.

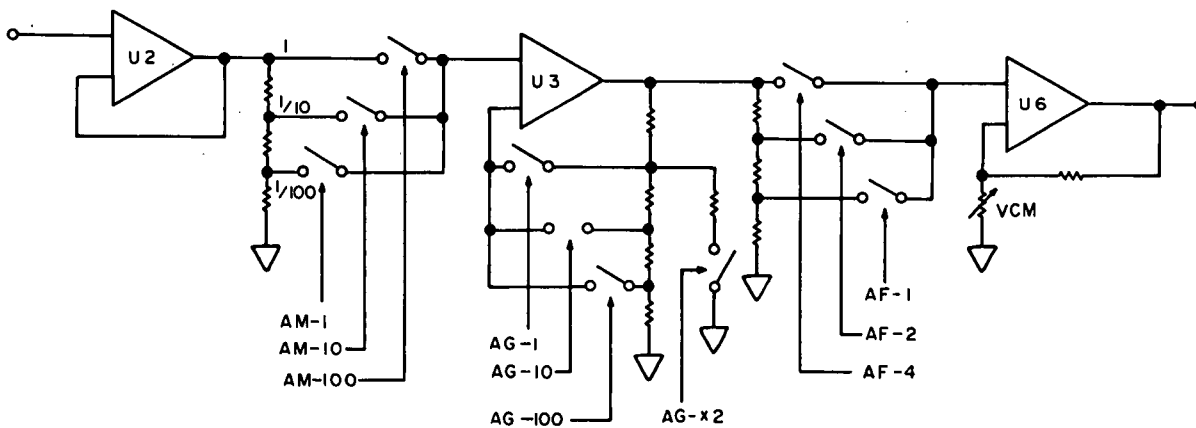

Figure 8-5. Relationship of Range Resistor and Gain Selection. (Sheet 1 of 2)

Table 8-A. Range Resistor and Gain Matrix.

FUNCTION	TEST FREQUENCY	L, C, R,  Z  RANGE									
		Z - 1	Z - 2	Z - 3	Z - 4	Y - 5	Y - 4	Y - 3	Y - 2	Y - 1	
C CAPACITANCE	100Hz ~ 250Hz	100mF	10mF	1000μF	100μF	10μF	1000nF	100nF	10nF	1000pF	
	250Hz ~ 2.5kHz	10mF	1000μF	100μF	10μF	1000nF	100nF	10nF	1000pF	100pF	
	2.5kHz ~ 25kHz	1000μF	100μF	10μF	1000nF	100nF	10nF	1000pF	100pF	10pF	
	25kHz ~ 100kHz	100μF	10μF	1000nF	100nF	10nF	1000pF	100pF	10pF	1000fF	
L INDUCTANCE	100Hz ~ 999Hz	100μH	1000μH	10mH	100mH	1000mH	10H	100H	1000H	10kH	
	1kHz ~ 9.99kHz	10μH	100μH	1000μH	10mH	100mH	1000mH	10H	100H	1000H	
	10kHz ~ 99.9kHz	1000mH	10μH	100μH	1000μH	10mH	100mH	1000mH	10H	100H	
	100kHz	100nH	1000nH	10μH	100μH	1000μH	10mH	100mH	1000mH	10H	
R,  Z  RESISTANCE IMPEDANCE	100Hz ~ 100kHz	100mΩ	1000mΩ	10Ω	100Ω	1kΩ	10kΩ	100kΩ	1000kΩ	10MΩ	
RANGE RESISTOR USED		x 5	10Ω	10Ω	10Ω	10Ω	10Ω	100Ω	1kΩ	10kΩ	100kΩ
		1 x 0.1 0.01	10Ω	10Ω	10Ω	100Ω	100Ω	1kΩ	10kΩ	100kΩ	100kΩ
Combination of RR, AM gain (attenuation) and AG (ampli- fier gain).	x 5	RR(Ω)	10	10	10	10	10	100	1k	10k	100k
		AM	x 100	x 10	x 1	x 1/10	x 10	x 10	x 10	x 10	x 10
		AG	20	2	2	2	2	2	2	2	2
	x 1	RR(Ω)	10	10	10	100	100	1k	10k	100k	100k
		AM	x 100	x 10	x 1	x 1	x 1	x 1	x 1	x 1	x 10
		AG	100	10	1	1	1	1	1	1	10
	x 0.1	RR(Ω)	10	10	10	100	100	1k	10k	100k	100k
		AM	x 10	x 10	x 1	x 1	x 1	x 1	x 1	x 1	x 10
		AG	100	100	10	10	10	10	10	10	100
	x 0.01	RR(Ω)	10	10	10	100	100	1k	10k	100k	100k
		AM	x 1	x 1	x 1	x 1	x 1	x 1	x 1	x 1	x 10
		AG	100	100	100	100	100	100	100	100	100

Figure 8-5. Relationship of Range Resistor and Gain Selection. (Sheet 2 of 2)

## 8-23 BLOCK DIAGRAM DISCUSSION

8-24 Analog Block Diagram. Figure 8-6 is a detailed block diagram of the 4274A analog section. The construction of this diagram is based on the actual printed circuit board assembly. It is useful for board level troubleshooting.

### 8-25. A6 Oscillator

The 9.6MHz crystal oscillator is designed to provide a wide range of test frequencies in either a 1-2-4 or 1-3-5 step frequency sequence. The basic frequency (9.6MHz) is the L.C.M (Least Common Multiple) that is 8 times any of the 11 test frequencies. The 8f (8 times test frequency) that is produced (9.6 MHz) is divided by a programmable divider (U13 thru U15 and U17 thru U19) to generate the desired test frequency and transferred to a quasi-sine wave generator which is composed of dividers (U7, U9 and U10) and a summing amplifier (Q6). The output waveform at Q6 Emitter is the composite (quasi-sine) of three squarewaves as illustrated in Figure 8-1. The quasi-sine wave is filtered by double low pass filters to form a clean sine wave and the output sine wave is automatically controlled by an ALC circuit (U1, U3 and U4) which converts its AC amplitude to a DC level. This DC level is fed back to a photo cell for providing the desired, consistent test signal levels.

### 8-26. A3 Power Amplifier

This board has two similarly designed amplifier paths: one to control the test signals to an appropriate amplitude across the unknown device (DUT) and another for receiving and feeding the unbalance voltages ( $e_{MOD}$ ) detected at A2 output back to the range resistors in the bridge section loop. In the DUT path, the test signal level is amplified in a vernier amplifier (Q1 and U1) whose gain is initially set by the OSC LEVEL control. This output signal is attenuated by the control signals (TLM and TLL) and amplified by 2 in a power amplifier (U2 and Q5 thru Q7) in accordance with the front panel MULTIPLIER settings (X0.01 thru X5). In the RR (range resistor) path, the unbalance voltage ( $e_{mod}$ ) is amplified by a vernier amplifier (Q9 and U3) whose gain is exactly the same as vernier amplifier (Q1 and U1) in the path. This amplified  $e_{mod}$  is attenuated in accordance with the OSC MULTIPLIER setting and again amplified with a power amplifier (U4 and Q15 thru Q18), then fed to the range resistor on the A1 board so that the current flowing through the range resistor ( $i_{RR}$ ) becomes exactly the same as the current flowing through the unknown device ( $i_X$ ).

### 8-27. A2 Modulator

The Modulator circuit receives the same test signal ( $e_{OSC}$ ) applied to the A3 board and produces a 90° phase shifted signal at the output of the 90° phase shifter (U1, U2 and U5). Thus there are two signals (sine waves) whose amplitudes are the same and their phase difference is 90°. The unbalance voltage ( $e_{nuo}$ ) transferred from A1 (Null Detector) is applied to both phase detectors (0° and 90°). The two signals are respectively applied to the 0° (U4) and 90° (U3) phase detectors through non-inverting tracking amplifier (U6 and U7) phase reference signals and also sent to the 0° and 90° modulators (U11 and U10). The unbalance voltage ( $e_{nuo}$ ) is delineated and detected as the 0° and 90° factors and respectively converted to proportional DC voltages in both the 0° and 90° integrators. These two DC voltages control the U10 and U11 modulators, respectively, and attenuate both AC signals from the input and output of the 90° phase shifter. The two signals modulated (attenuated) by such DC voltages are proportional to the 0° and 90° parts of the unbalance voltage ( $e_{nuo}$ ) and summed in a summing amplifier (U9). The output signal ( $e_{mod}$ ) is sent to the range resistor power amplifier.

### 8-28. A1 Range Resistor and Null Detector.

While the bridge section is being balanced, two currents ( $i_{RR}$ ,  $i_D$ ) flow into the A1 board from the LCUR and LPOT terminals of the UNKNOWN terminal. During the bridge unbalance time ( $i_X = i_{RR}$ ),  $i_D$  flows into the Null Detector (U3 and Q12 thru Q16) and this current is converted to a proportional voltage signal. There are two main signal paths on the A1 board. And its two main functions are to detect the unbalance voltage and to deliver this voltage to the Modulator so that unbalance current ( $i_D$ ) becomes zero amperes ( $i_X = i_{RR}$ ) and to feed an  $e_{ERR}$  signal to A4 process amplifier input. Circuit gain amplitude between the Null Detector and the Unbalance Detector is controlled so as to be consistent with the control signal from the digital section. The unbalance current ( $i_D$ ) applied to Null Detector (U3 and Q12 thru Q16) is converted to a proportional unbalance voltage whose amplitude is calculated by the product of  $i_X$  and the feedback resistor. The unbalance voltage is filtered and amplified in two amplifier stages (U6 and U7) and sent to both the unbalance detector and to the A2 Modulator.

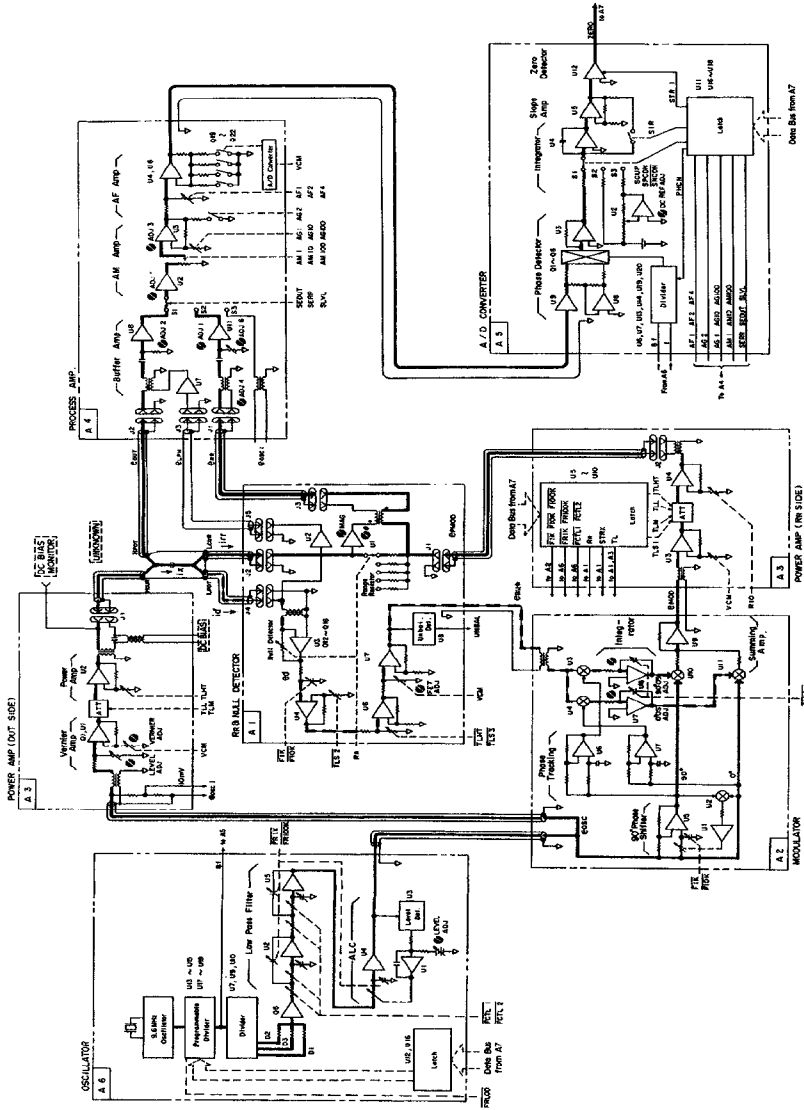

FIGURE 8-6. ANALOG SECTION BLOCK DIAGRAM

Model 4274A

As long as an unbalance voltage signal (E<sub>U</sub>) appears at the output of U7, the unbalance detector (U8) amplifies this UNBAL signal and sends it to the digital section to announce that the bridge is not yet balanced. The output (100 ohm) is comprised of a range resistor (R10), a 100k potentiometer, and a 100 ohm resistor. The voltage (E<sub>U</sub>) across the range resistor is applied by the relay main range resistor to the input of the process amplifier (A4). There is a complex relationship between the selected range resistor, the function, test frequency and test signal level as selected on Front panel. These relationships are shown in Figure 8-5. Buffer amplifier (U1) is provided to compensate for the voltage drops which resistively appear between the U1U and the range resistor.

8-29. M Process Amplifier  
The process amplifier board receives two main signals (E<sub>UT</sub> and E<sub>BR</sub>) and two subordinate signals (E<sub>LPH</sub> and E<sub>DCS</sub>) signals. E<sub>UT</sub> and E<sub>BR</sub> are periodically passed through FET switches (S1 and S2) which are activated by control signals (START and STOP). E<sub>UT</sub> is transferred to an amplifier (U2). S1 and S2 resistors are closed when S1 and S2 are selected. The output of U2 is transferred to a range resistor (R10) and a 100 ohm resistor. The voltage (E<sub>U</sub>) across the range resistor is applied by the relay main range resistor to the input of the process amplifier (A4). There is a complex relationship between the selected range resistor, the function, test frequency and test signal level as selected on Front panel. These relationships are shown in Figure 8-5. Buffer amplifier (U1) is provided to compensate for the voltage drops which resistively appear between the U1U and the range resistor.

8-30. A/D Converter  
The E<sub>UT</sub> signal is transferred from M1 process amplifier to an unbalance detector (U1) through U1U and U1V. The detected signal is selected and filtered. The detected signal is passed through switch S1 while the S<sub>1</sub>QIP (Start Change-up) is being transferred from the latch (which is controlled by the digital section) and the integrator (U4) is charged for a period of about 10ms. After this charging cycle, the slope amplifier (U5) drives the zero comparator (U2) to detect the polarity and switch S2 or S3 is closed by the S<sub>2</sub>QIP (Start Positive Charge Down) circuitry depending on the polarity discrimination of the integrator voltage. The integrator discharges until the discharge crosses the zero (0) volts level. When the discharge reaches zero volts, a zero detect signal is sent to the digital section. The time period between the start of discharge and the zero crossing point is proportional to the real part of E<sub>UT</sub>. In like manner, the real part of E<sub>BR</sub>, the imaginary part of E<sub>UT</sub> and the imaginary part of E<sub>BR</sub> are successively detected and converted into digital data.

Q19 thru Q22 successively conduct to improve the gain as the VCR (Voltage Control Middle) level is decreased at the Front panel. E<sub>LPH</sub> is transferred from A1 to A4 to compensate for the residual offset present at the input of the process amplifier (A4). E<sub>DCS</sub> is the selected subordinate signal. E<sub>DCS</sub> is the reference for the test signal level measurement for doing equivalent vector ratio calculations with the E<sub>UT</sub> signal. (Instead of E<sub>BR</sub>) in virtual device measurements. Switch S3 is closed by the S<sub>3</sub>QIP (Select Level) signal while the V key is being pressed on the Front panel.

8-29. M Process Amplifier  
The process amplifier board receives two main signals (E<sub>UT</sub> and E<sub>BR</sub>) and two subordinate signals (E<sub>LPH</sub> and E<sub>DCS</sub>) signals. E<sub>UT</sub> and E<sub>BR</sub> are periodically passed through FET switches (S1 and S2) which are activated by control signals (START and STOP). E<sub>UT</sub> is transferred to an amplifier (U2). S1 and S2 resistors are closed when S1 and S2 are selected. The output of U2 is transferred to a range resistor (R10) and a 100 ohm resistor. The voltage (E<sub>U</sub>) across the range resistor is applied by the relay main range resistor to the input of the process amplifier (A4). There is a complex relationship between the selected range resistor, the function, test frequency and test signal level as selected on Front panel. These relationships are shown in Figure 8-5. Buffer amplifier (U1) is provided to compensate for the voltage drops which resistively appear between the U1U and the range resistor.

Model 4274A



8-31. CONTROL SECTION

8-32. A9 MPU Board  
The microprocessor, 18k ROM, 2k x 8 bit static memory, (one 9) x 2k x 8 bit ROM -- one is used for HP-IB option) and the 1024 x 8 bit static memory (2 x 512 x 8 bit RAM). This assembly controls the initial display self-diagnostic test, initial control settings, measurement mode, zero offset cancellation, self diagnostic test and other functions. It also performs numerical computations for displaying measurement data on the front panel. To accomplish this control and to do the numerical computations, the ROM's are used to store the assigned addresses. The ROM's are used to store the various management instructions which include:

- a. WVD processing control for L, C, R and other measurements.
- b. WVD processing control for self diagnostic test.
- c. Key control.
- d. Display control.
- e. Utility program.
- f. Mathematics pack.
- g. Computation program.
- h. Main program.
- i. Table and DC bias control.
- j. HP-IB control.

The Microprocessor fetches the appropriate control program in accordance with front panel control settings and outputs the desired measurement results as well as doing a self-diagnostic test evaluation. Both measurement and diagnostic test results are displayed on the front panel displays.

8-33. A8 Display Control, A10 Display and Key Board.  
This board controls the key information set at the front panel and houses the data ma-

trix for the seven (7) segment numeric displays. When a given panel key is depressed, the information is sent to interrupt decoder (U14) through the KVP1 signal. A7 peripheral control board and simultaneously key scan counter (U15). New key information is sent to the MPU through the bus lines (PMD-6). The MPU addresses new address to execute any new function set at the front panel and transmits the necessary key information to A10 multiplexer for turning appropriate key LED's on. Measurement result data computed on the MPU board are transferred to three groups of display RAMs (U16-U18) through 8 address lines (PMD-7) to the appropriate RAM in synchronization with the MPU. These data are then stored in ME1 thru ME3 in accordance with the addresses of the numerical data and the unit data information for both Display-A and Display-B. These RAM outputs, respectively, control the cathode driver (U14) to activate the three groups of display LED's.

8-34. Peripheral Control Board  
The peripheral control board includes the peripheral interface adapter (PIA), the HP-IB controller, the timing control section and the data counter. The PIA (U17) provides a universal means for interfacing peripheral equipment to the MPU through two 8 bit bidirectional peripheral data buses. Its function is programmed by the MPU. The PIA has four (4) control lines and no external logic is required to communicate with other peripherals. The MPU addresses the PIA to enable the circuits associated with the PIA to act in accordance with the information signals through the HP-IB bus. The PIA includes two data banks which are selected by the MPU. Two data output buses are identified as peripheral A (PA) and peripheral B (PB). PA data are sent to two multiplexers (U30 and U31) and decoded to 24 bit control signals (19 lines are virtually used). These signals mainly manage the gain control for the T80 and V30 sections. Other PE data are sent to the logic control (U11) which produces the timing pulses for counter (U12 and U25) and the data information (U13) during the period that is proportional to the time data from the A-D converter.

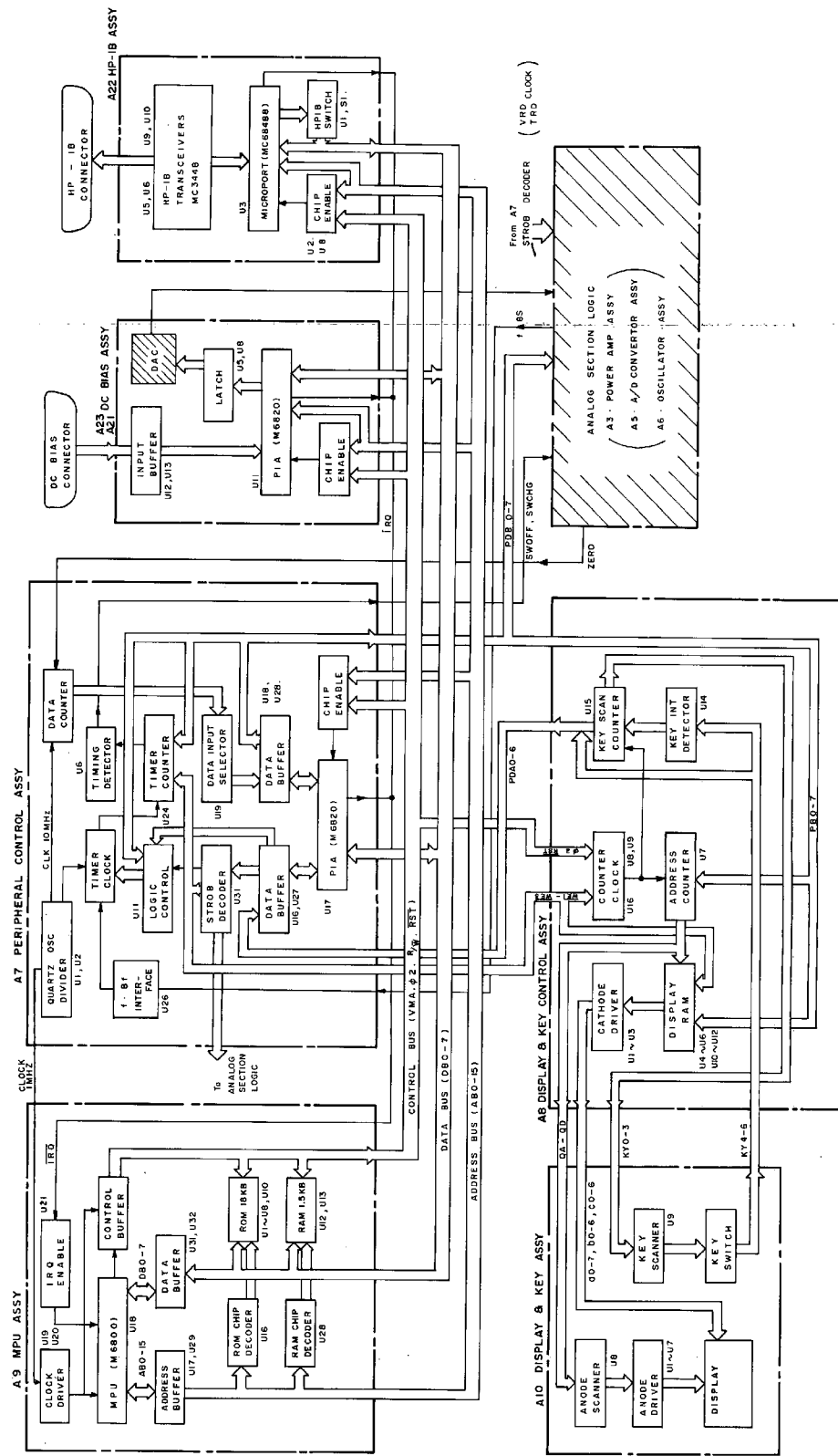

FIGURE 8-7. Control Section Block Diagram

8-35. TIMING DIAGRAM DISCUSSION

8-36. As described in Table 8-1, five measurement cycles are repeated to do the vector ratio calculation of an unknown device to produce a measurement result. This paragraph describes the timing sequence of the five fundamental component A-D conversions: VRD clocks (VRDCLK) 1 thru 4 are decoded by the STROB clock decoder in A7 which receives the data from the MPU. When the power is switched on, the MPU is initialized and fetches the programmed data for A9U1 that manages the VRD sections. VRDCLK1 mainly generates the control signals which determine the measured components ( $0^\circ \times \text{EDUT}$ ,  $0^\circ \times \text{ERR}$ ,  $90^\circ \times \text{EDUT}$  and  $90^\circ \times \text{ERR}$ ) and the states of the A-D converter by synchronizing the data from the MPU.  $\text{EDUT}$  is measured while  $\text{SEDUT}$  (Select  $\text{EDUT}$ ) is high and  $\text{ERR}$  is measured while  $\text{SERR}$  (Select  $\text{ERR}$ ) is high for the admittance measurement. This relationship changes when an impedance measurement is being done.  $\text{SLVL}$  (Select Oscillator Level) is set high instead of  $\text{SERR}$  for measuring the voltage across the unknown device while the V key on the front panel is being depressed.

The ADC integrator is reset on the first cycle, to be ready for A-D conversion, while  $\text{SIR}$  is high.  $\text{STCUP}$  goes high on the positive edge of  $\text{STCUP}$  so as to be ready and the input signal charges the integrator for 10 milliseconds. A polarity check ( $\text{PLTCHK}$  of  $\text{VRV4}$ ) is done during the next  $500\mu\text{S}$  (approximately) so that charging is in the proper direction. A small charge for the next  $400\mu\text{S}$  (approximately) is done while  $\text{SPCDN}$  is high (charge down phase 1). This small charge is necessary so that an accurate measurement can be made when the input signal value is small. As the charge voltage is positive, the processor signals that integrator should be discharged in a negative direction ( $\text{SNCDN}$ ). The integrator starts discharging on the positive edge of  $\text{SNCDN}$  until its DC level crosses zero volts (charge down phase 2).  $\text{ZRCMP}$  (Zero Compare) goes low when the discharge reaches zero volts and the timing-end detector is reset ( $\text{SNWOFF}$ ) to low and  $\text{SNCDN}$  is set high to stop the discharge phase and to, simultaneously,

set  $\text{SIR}$  high. The time data for this discharge phase (charge down phase 2) is transferred to the processor for storing in the static memory during the period of Data Transfer. In like manner, AD conversion for 0 components of  $\text{EDUT}$  and  $\text{ERR}$  is accomplished and  $\text{PHCH}$  ( $\text{VRDCLK}$  3) is set high to detect  $90^\circ$  components in the phase detector. The timing sequence of  $\text{VRDCLK1}$  and  $\text{VRDCLK4}$  are inseparably related to repeat same processing of charge and discharge cycle for next component measurement to serially send time data to digital section.

$\text{VRDCLK2}$  and  $\text{VRDCLK3}$  clocks are provided to generate the control signals which mainly determine the appropriate gain in the matrix that is determined by the test frequency measurement range, function and  $\text{OSC}$  MULTIPLIER. This timing diagram shows the timing states for an admittance measurement.  $\text{EDUT}$  ( $0^\circ$  and  $90^\circ$ ) are amplified by  $\text{AM1}$  during the time that  $\text{AM1}$  is set high and  $\text{ERR}$  ( $0^\circ$  and  $90^\circ$ ) are amplified by  $\text{AM10}$  during the time that  $\text{AM10}$  is set high so to obtain a ten times ( $\times 10$ ) voltage ratio. Also,  $\text{EDUT}$  ( $0^\circ$  and  $90^\circ$ ) are amplified by  $\text{AF1}$  when  $\text{AF1}$  is set high and  $\text{ERR}$  ( $0^\circ$  and  $90^\circ$ ) is amplified by  $\text{AF2}$  when  $\text{AF2}$  is set high.

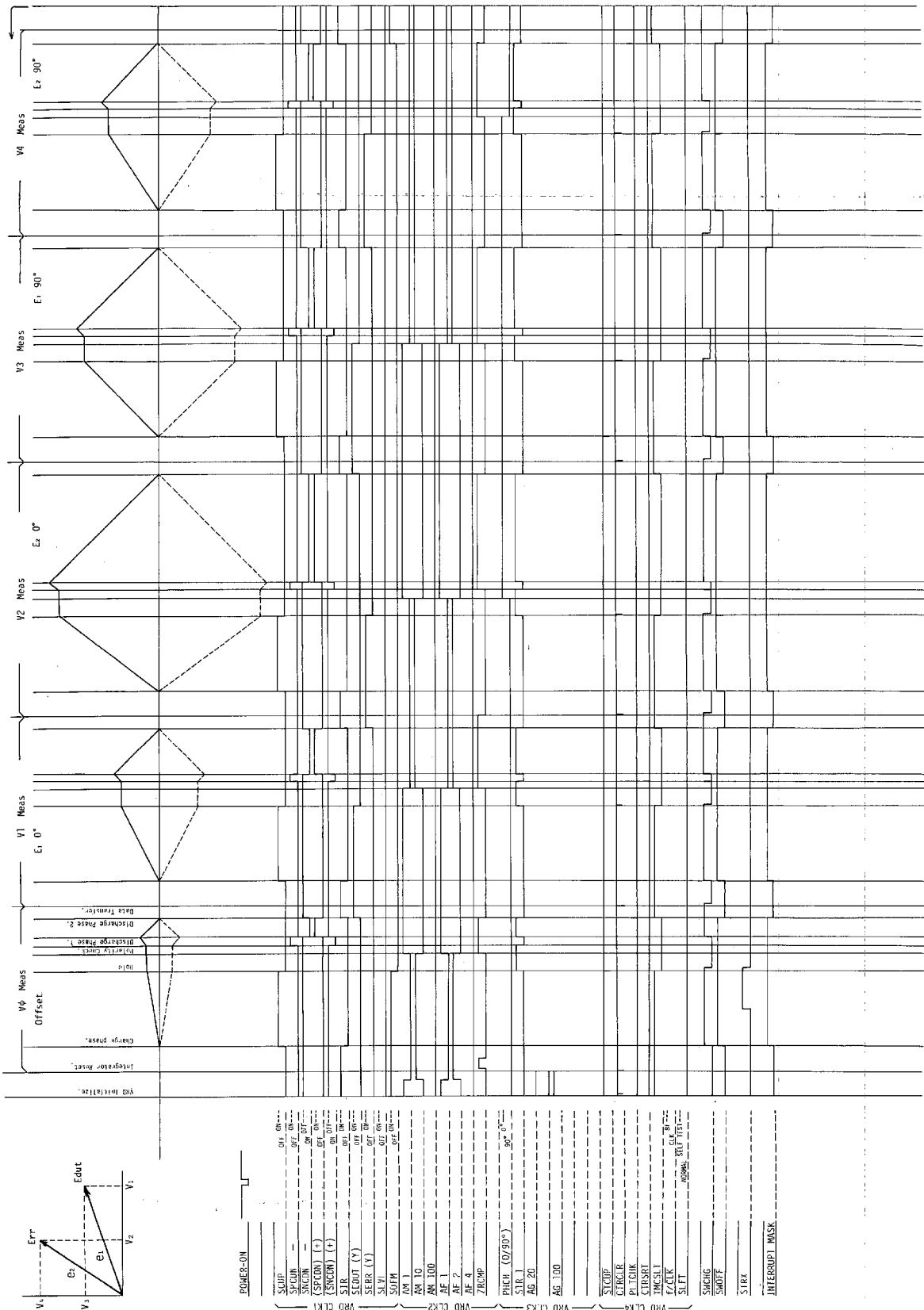

FIGURE 8-8. Timing Diagram  
8-17

Table 8-1. Mnemonic Information.

Mnemonic	Description	Mnemonic	Description
AB	Address Bus	PDA	Peripheral Data A
AF	Amplifier for Frequency	PDB	Peripheral Data B
AF1	Amplifier Frequency 1. (AF Attenuator: 1/4)	$\overline{\text{PRST}}$	Preset
AF4	Amplifier Frequency 4. (AF Attenuator: 1/1)	$\overline{\text{RST}}$	Reset
AG	Amplifier Gain	R/ $\overline{\text{W}}$	Read Write
AG1	Amplifier Gain x1	R10	Range Resistor 10 $\Omega$
AG100	Amplifier Gain x100	R100K	Range Resistor 100k $\Omega$
AM	Amplifier Multiplier	SCUP	Start Charge Up
AM1	Amplifier Multiplier x1 (Attenuator: 1/100)	SEDUT	Select Device Under Test Voltage
AM100	Amplifier Multiplier x100 (Attenuator: 1/1)	SERR	Select Range Resistor Voltage
BLCLK	Blanking Clock	SLVL	Select OSC Level
CBLNG	Cable Length SW on	SIR	Set Integrator Reset
CSA	Chip Select A	SNCDN	Start Negative Charge Down
CSB	Chip Select B	SPCDN	Start Positive Charge Down
DB	Data Bus	$\overline{\text{STADLD}}$	Start Address Load
DBE	Data Bus Enable	STRX	Strobe X
DCHON	DC Bias High ( $\pm 100\text{V}$ ) on	$\overline{\text{STPSCN}}$	Stop Scan
$\overline{\text{DSBL}}$	Disable	SWCHG	Switching
EXTCD	External Clock Drive	SWOFF	Switch Off
eLPH	Low Potential Compensate High Potential	TLHT	Test Level Highest
eMOD	Modulated Signal	TLL	Test Level Low
eMODG	Modulated Signal Ground	TLM	Test Level Middle
eNUO	Null Detector Out Signal	TLS	Test Level Small
eNUOG	Null Detector Out Ground	TRDCLK	Transducer Clock
eOSC	Reference Signal	$\overline{\text{TRON}}$	Turn On
FCTL	Filter Control	VCH	Voltage Control High
FRCLK	Frequency Clock	VCI	Voltage Control In Phase
FRL0D	Frequency Load	VCL	Voltage Control Low
FROPT	Frequency Option Select	VCM	Voltage Control Middle
IRQ	Interrupt Request	VCQ	Voltage Control Quadrature
$\overline{\text{KYIPT}}$	Key Input	VMA	Valid Memory Address
$\overline{\text{NMI}}$	Non Maskable Interrupt	VRDCLK	Vector Ratio Detector Clock
		$\overline{\text{WE}}$	Write Enable
		ZERO	Zero Detect Pulse
		$\phi$	Clock

8-37. TROUBLESHOOTING.

CAUTION

THE OPENING OF COVERS OR REMOVAL OF PARTS, EXCEPT THOSE TO WHICH ACCESS CAN BE GAINED BY HAND, IS LIKELY TO EXPOSE LIVE PARTS; IN ADDITION, ACCESSIBLE TERMINALS MAY ALSO BE LIVE.

THE APPARATUS SHALL BE DISCONNECTED FROM ALL VOLTAGE SOURCES BEFORE ANY ADJUSTMENT, PARTS REPLACEMENT OR MAINTENANCE AND REPAIR ARE PERFORMED FOR WHICH THE APPARATUS MUST BE OPENED.

IF, AFTERWARDS, ANY ADJUSTMENT, MAINTENANCE OR REPAIR OF THE OPENED APPARATUS UNDER VOLTAGE IS REQUIRED, IT SHALL BE CARRIED OUT ONLY BY A SKILLED PERSON WHO IS AWARE OF THE HAZARD INVOLVED.

8-38. Figure 8-9 "How to Use Troubleshooting Guides" is helpful when starting to troubleshoot the 4274A. As the analog boards include the latches which are controlled through bus lines by the MPU, the signature analysis technique is useful for analog board troubleshooting. The sequence of the digital section troubleshooting depends upon the program routine and it is difficult to provide individual flow diagrams. AL thru GL all contain digital section troubleshooting aids.

8-39. Follow the troubleshooting procedure in Figure 8-9 which provides specific instructions for isolating the Analog and Digital section from each other.

WARNING

WHENEVER IT IS LIKELY THAT THE PROTECTION PROVIDED BY THE FUSES HAS BEEN IMPAIRED, THE INSTRUMENT MUST BE MADE IN OPERATING AND MUST BE SECURED AGAINST ANY UNINTENDED OPERATION.

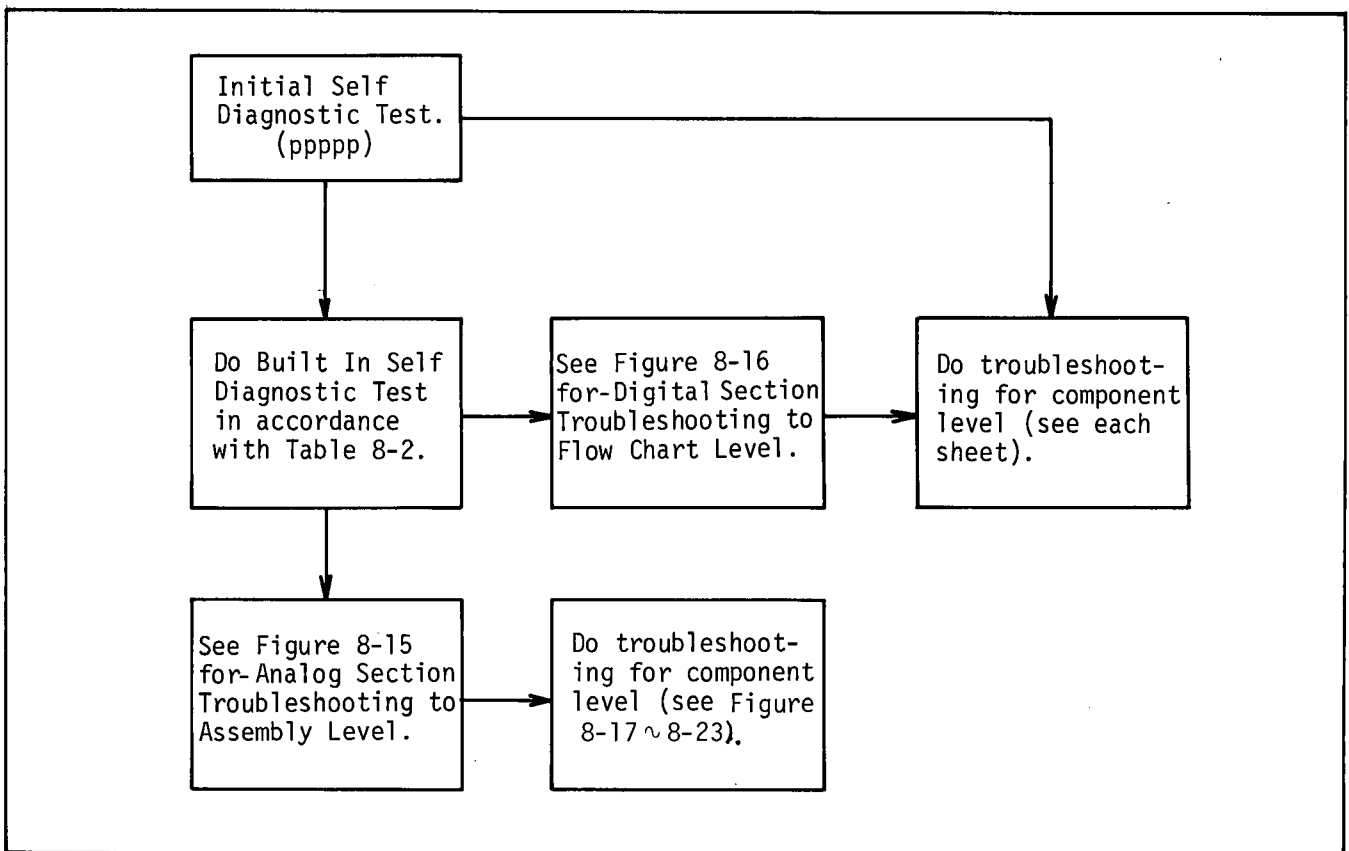

Figure 8-9. How to Use Troubleshooting Guides.

CAUTION

CAPACITORS INSIDE THE INSTRUMENT MAY STILL BE CHARGED EVEN IF THE INSTRUMENT HAS BEEN DISCONNECTED FROM ALL VOLTAGE SOURCES.

BE SURE THAT ONLY FUSES OF THE REQUIRED RATED CURRENT AND OF THE SPECIFIED TYPE ARE USED FOR REPLACEMENT. THE USE OF MENDED FUSES AND THE SHORT-CIRCUITING OF FUSE HOLDERS MUST BE AVOIDED.

8-40. Troubleshooting Analog Section to Assembly Level. Follow the troubleshooting procedure in Figure 8-15 Analog Section Troubleshooting Guide to isolate an analog fault to a board assembly. Troubleshooting to component level is covered in the service sheet for each assembly.

8-41. Digital Section Troubleshooting Figure 8-16 is helpful in speeding the troubleshooting. The signals circulate through the bus line and the flow diagrams are given in accordance with the main instructions of the 4274A for efficient problem isolation. The signature analysis technique is a most helpful method for following the component isolation flows AL thru GL (A Logic flow thru G Logic flow). Except for the HP 5004A Signature Analyzer, no additional boards or equipment are necessary.

8-42. Initial Self Diagnostic Tests just after SW-ON.

ROM and RAM test:

BLANK	CHECK SUM ERROR.....	A9U10
P .....	↗	... A9U7,8
PP .....	↗	... A9U5,6
PPP .....	↗	... A9U3,4
PPPP .....	↗	... A9U1,2
PPPPP ...	READ WRITE TEST ERROR ...	A9U12, 13

The above simple isolation tests for ROM and RAM faults can be performed except that faults in the bus line because it is interrupted or abnormally affected (or perhaps the ROM in which the self test instruction is programmed is defective).

If these tests are satisfactorily performed, advance to self test open and short test on the assumption that the digital section is operating normally (for at least its major functions).

8-43. Built-in Self Test.

The 4274A has the capability for automatically performing a brief self-diagnostic routine for the heart of the logic control circuits (microprocessor, ROM and RAM).

This diagnostic procedure is started automatically and is completed just after switching power to ON. Its completion can be recognized by the "p" figures that sequentially appear (up to five(5) in left to right direction) on display A. The meaning of the display condition, if the instrument doesn't arrive and stop at initial control settings as described in Paragraph 3-19 of page 3-17, indicate the problem location for roughly isolating the malfunction.

The display counts for op-01 thru op-05 can be read when the sequential test is stopped by depressing SELF-TEST and D thru L/C keys of display A function.

A manual self-diagnosis of the main functions of the analog section and major control capabilities of the control section can be progressively observed by pressing the self-test key on the front panel. As described in Section V, some steps can be utilized to do adjustments. Simplified explanations of what is tested and what is possibly defective is described in Table 8-2.

Table 8-2: Built-in Self Test Function (Sheet 1 of 3).

Error Message	Display	Test Content Implemented.	Tested Circuits	Meaning of Error Message
<p>OP 01</p>	A	<p>MPU functions to open A5Q12 and to close A5Q11 to establish the DC 0 volts at pin-3 of A5U9. This DC voltage is measured by two methods (using the +DC and -DC reference voltages) and are added to display.</p>	A5	<p>A5 A/D Converter.</p> <p>1) This error message means that both integrator and comparator have a time delay that cannot be neglected.</p> <p>2) Or the integrator isn't operating normally or ±DC reference voltages aren't correct.</p>
	B	<p>The CPU operates to open A5Q9, thus isolating the PHASE DETECTOR. In this condition, the +DC reference voltage (+6.3V) charges the integrator and discharges on the -DC reference voltage. During the next sequence, the -DC reference voltage charges the integrator and discharges it on the +DC reference voltage.</p> <p>These two measured values are mathematically added together in the digital section to display nearly zero on display - B.</p>		
<p>OP 02</p>	A	<p>This test compares the two measured values of the EDUT signal via two different attenuator paths and calculates the ratio:</p> <p>path 1. Combination of x1 AM and X1 AF attenuators.</p> <p>path 2. Combination of X1 AM and X1/2 AF attenuators.</p> <p>Since EDUT is constant, the path 1 measured value is twice the value of the path 2 measured value.</p> <p>For easier reading at high resolution, the results in path 2 are multiplied by two and their ratio calculated in the digital section for displaying nearly 1000.00 on display-A. (Decimal point location is not controlled).</p>	A3 A4	<p>AM/AF amplifier</p> <p>This error message means either of the AF attenuators (x1 and x1/2) of the AF amplifier aren't adjusted for correct attenuation accuracy.</p> <p>Error messages op-02~op-05 appear when the measurement result described at left is not within 1000.00±160 counts on display-A.</p>
	B	<p>The combined residual phase offsets of various attenuators including the AM (1, 1/10, 1/100) attenuator and the AF (1, 1/2, 1/4) attenuator are measured and displayed on display-B.</p>		



Table 8-2. Built-in Self Test Function(Sheet 2 of 3).

Error Message	Display	Test Content Implemented.	Tested Circuits	Meaning of Error Message
OP 03	A B	This test repeats equivalent measurement, calculation and display as outlined for op-02 for following combination of AF and AM attenuators: path 1: Combination through (1) AM and 1/2 AF attenuators. path 2: Combination through (1) AM and 1/4 AF attenuators.	A3 A4	AM/AF amplifier. This error message means that either the AF attenuators(x1/2) and x1/4 of AF amplifier aren't being properly controlled or aren't adjusted for proper attenuation accuracy.
OP 04	A B	This test repeats equivalent measurement, calculation and display as outlined for op-02 for following combination of AF and AM attenuators: path 1: Combination of 1/10 AM plus 1/1 AF attenuators. path 2: Combination of 1/1 AM and 1/4 AF attenuators.	A3 A4	AM/AF amplifier. This error message means that either the AM attenuator (1/10) and/or the AF attenuator (1/4) aren't being controlled properly or aren't adjusted for proper attenuation accuracy.
OP 05	A B	This test repeats equivalent measurement, calculation and display as outlined for op-02 for following combination of AM and AF attenuators: path 1: Combination of 1/10 AM and 1/4 AF attenuators. path 2: Combination of 1/100 AM plus 1/1 AF attenuators.	A3 A4	AM/AF amplifier This error message means that either the combination of the 1/10 AM and 1/4 AF attenuators and/or combination of 1/100 AM (through 1/1 AF attenuators) aren't being controlled properly or aren't adjusted for proper attenuation accuracy.
OP 07	A B	Offset is measured against minimum of i/v converter and amplifier on A1 board. Consequently, any offset here is significant when measured against the main signal and can be displayed with high resolution.	A1 A2	Total offset measurement of A1 and A2. This error message means that total offset in A1 thru A2 assemblies is excessive (for maintaining accurate bridge balance).
OP 10	C	Oscillator and power amplifier check. 5Vrms measurement	A3 A6	Error message op-10, op-11, op-12 or op-13 appear, if measured voltage values are not within ±20% of proper voltages. OSC LEVEL has to be set to its fully cw positions.
OP 11	C	1Vrms measurement		
OP 12	C	0.1Vrms measurement		
OP 13	C	0.01Vrms measurement		
OP 14	/	1MΩ Range	A1	This error message means that appropriate resistor range isn't selected, or the resistance value of respective range resistor has shifted to an abnormal value.
OP 15	/	100KΩ Range	A4	

Table 8-2. Built-in Self Test Function (Sheet 3 of 3).

Error Message	Test Contents implemented.		Tested Circuits	Meaning of Error Message
OP 16	10kΩ Range	Admittance measurement of open (OS) unknown condition at selected frequency with x1 MULTIPLIER setting for respective range of function R.	A1	This error message means that appropriate resistor range isn't selected, or the resistance value of respective range resistor has shifted to an abnormal value.
OP 17	1kΩ Range		A4	
OP 18	1MΩ Range	Admittance measurement of open (OS) unknown condition at selected frequency with x5 MULTIPLIER setting.	A1	Same operating test is repeated except the test signal level. If open tests 14 thru 17 are passed and one of 18 to 20 is failed, OSC LEVEL control isn't satisfactorily performed.
OP 19	10kΩ Range	Admittance measurement of open (OS) unknown condition at selected frequency with x.1 MULTIPLIER setting.	A4	
OP 20	1kΩ Range	Admittance measurement of open (OS) unknown condition at selected frequency with x.01 MULTIPLIER setting.	A4	
SH 21 2 SH 23 SH 25	Impedance measurement of unknown in a shorted condition on the 100Ω range with sequential change of MULTIPLIER setting (x5, x1, x.1 and x.01).		A1 2 A3	An error message in this column means that the bridge cannot be balanced.
SH 24	Current that flows through shorted DUT is 100mA since OSC level is +5Vrms and OSC output impedance is nearly 50. This current also flows through range resistor and voltage drop is measured and compared with the test limited calculated in logic section.		A1 A3 A4	This error message can mean any of the following: 1. OSC level is less than 80% of required value of 5Vrms. 2. Bridge cannot be balanced. 3. Appropriate gain controls of AM AMP and AG AMP isn't being performed. (AG AMP: x 20, AM AMP: x 100)
SH 26	Same measurements and calculations are implemented at OSC level settings of 1Vrms with range resistor on 100 range.		A1 A3 A4	This error message can mean any of the following: 1 OSC level is less than 80% of required value of 1Vrms. 2 100Ω range resistor has shifted to an abnormal value or appropriate control for range resistor isn't being performed. 3 Appropriate gain controls of AM AMP and AG AMP isn't being performed. (AG AMP: X1, AM AMP: x 1)
SH 27	Sequential current measurements are done for shorted (0Ω) unknown in a condition for 100Ω, 1kΩ and 10kΩ range resistors.		A1	This error message means that either the range resistor (100Ω, 1k and 10kΩ) value is inappropriate (if short tests 24 and 26 are satisfactory).

### Digital Section Troubleshooting Using Signature Analyzer.

The advantage of troubleshooting based on "Signature Analysis" is accuracy and ease in finding failures. It is generally difficult to search for an error by means of observing waveforms on an oscilloscope for the reason that bit trains in a digital circuit seem to be much the same whichever is observed. Specifically, to find the errors in a stream of large bit size (or word length) data takes much time and requires the use of an instrument such as a logic state analyzer. Hewlett-Packard has proposed a method called "Signature Analysis" which recognizes the bit pattern measured in a 4 digit hexa decimal code (signature) for running an easy diagnostic test program. With the Signature Analyzer (HP 5004A), the signatures are displayed in a readable 4 digit-figure set of alphanumeric figures (0 1 2 3 4 5 6 7 8 9 A C F H P U). Signature analysis is based on the usual signal tracing method followed in troubleshooting an analog circuit. According to signature analysis, devices in a digital circuit are checked with the signal analyzer by comparing signal input and output signatures to and from each device for the "correct" signature denoted in the service manual signature map. If a signature is not identical, the troubleshooter need only trace the bit train in the opposite direction of the signal flow and, when a device is noted which generates an erratic signature despite a correct input, the component may be regarded as faulty.

#### Signature Analysis for the 4274A.

For doing signature analysis, a DSA (Data Stream Analysis) switch is provided on the A9 (MPU) board of the 4274A. No additional test board is required. There are twenty-one (21) kinds of DSA for performing signature troubleshooting and they are identified by the abbreviated names of DSA-1 thru DSA-21. These names are denoted around the signature pattern in the respective schematic and troubleshooting trees for setting the signature analyzer and the 4274A for appropriate control settings, window setting, DSA switch position of A9 board and other necessary conditions of the 4274A.

#### SIGNATURE ANALYZER TECHNIQUE.

An active digital hand-held logic tracer coupled with an active pod (with four miniature clip connection leads) is sufficient for detecting the test signal and for development of the signature on the Signature Analyzer display. The active probe has access to the desired node in the circuit being tested and transfers this input data to the analyzer. The four input leads of the test cable active pod connect the gate signals --- START, STOP and CLOCK --- from the instrument being tested to the analyzer. The remaining lead is connected to instrument GND. The START signal is an open "window" (measurement gate) signal which causes the signature analyzer to prepare for receiving data via the active probe. The STOP signal causes the window to close. The CLOCK is taken from the time base of the instrument and permits receiving input data and gate signals in synchronization. Polarity of the gate signal active (enable) edges (positive or negative) can be selected by the front panel controls of the signature analyzer. Probing points and connection locations of START, STOP and CLOCK leads are designated on the troubleshooting flow diagrams.

Figure 8-10. Signature Analysis Guide(Sheet 1 of 2).

Signature Analysis Diagnostic Flow Diagram Notes.

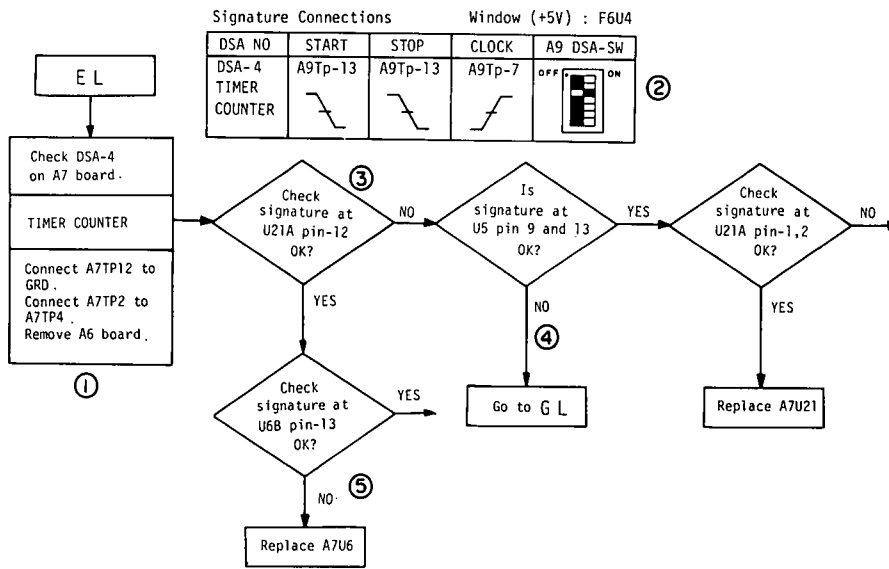

Figure A.

1. For doing Signature Analysis in EL flow chart, arrange the settings given in bottom box.
2. Set DSA switch of A9 MPU board as shown in right box. Both START and STOP signals are taken from A9TP13. CLOCK signal is taken from A9TP7. Front panel control settings for Signature Analyzer are:
  - START button: depressed ()
  - STOP button: depressed ()
  - CLOCK button: released ()

Check that signature of +5V supply is F6U4 (this step is omitted from step by step flow chart).
3. Compare actual signatures with signatures of DSA-4 signature map (see Figure-B). If not identical, go to step 4.
4. In like manner, compare actual signature and if not identical, go to GL flow chart.
5. In like manner, compare actual signature and if not identical, replace A7U6.

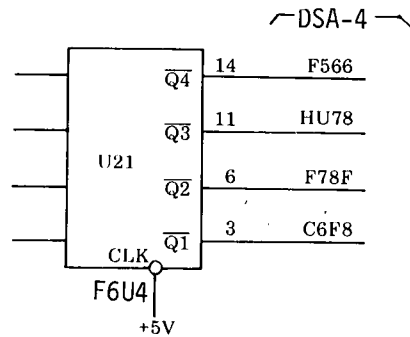

Figure B.

Figure 8-10. Signature Analysis Guide (Sheet 2 of 2).

8-44. Disassembly of A10 (Display and Key) Board

To replace the parts mounted on A10 board assembly, the front panel has to be removed from the front frame of the 4274A. The procedure is as follows:

1. Carefully remove trim strip from top of front frame (without bending trim strip).
2. Remove the three screws from top of front frame.
3. Remove the two foot assemblies and three screws from bottom of front frame.
4. Press front panel assembly forward (from inside) without adding strong stress to the cable assemblies which are connected between front panel and main body.
5. Remove the nine (9) screws from A10 board assembly and the now accessible associated parts around the front panel and the A10 board assembly.

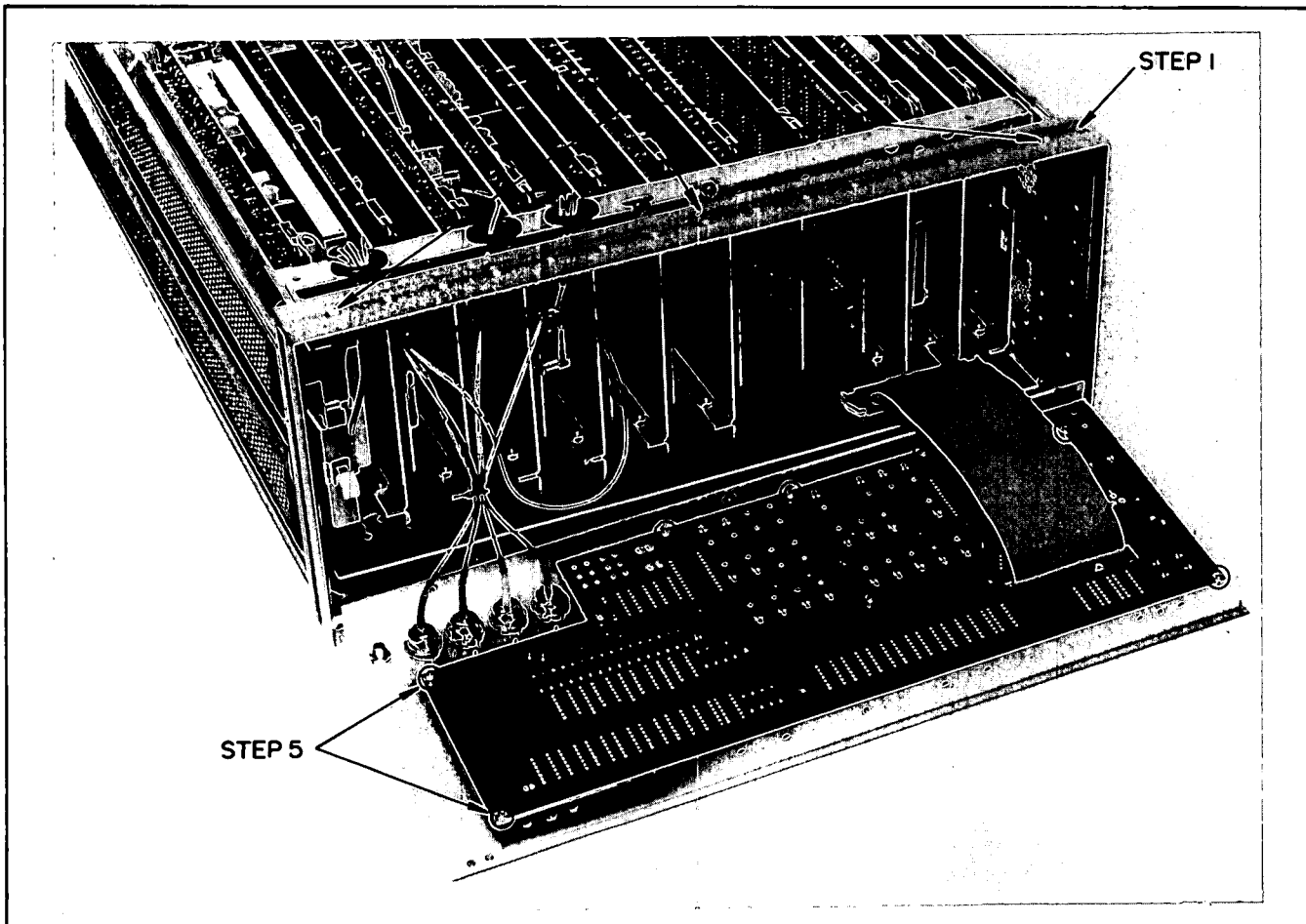

Figure 8-11. A10 Display and Key Board Disassembly.

## 8-45. PRODUCT SAFETY CHECKS.

## WARNING

WHENEVER IT APPEARS LIKELY THAT SAFETY PROTECTIVE PROVISIONS HAVE BEEN IMPAIRED, THE APPARATUS SHALL BE MADE INOPERATIVE AND BE SECURED AGAINST ANY UNINTENDED OPERATION. THE PROTECTION IS LIKELY TO BE COMPROMISED IF, FOR EXAMPLE:

- THE APPARATUS SHOWS VISIBLE DAMAGE.
- THE INSTRUMENT FAILS TO PERFORM THE INTENDED MEASUREMENT.
- THE UNIT HAS UNDERGONE PROLONGED STORAGE UNDER UNFAVORABLE CONDITIONS.
- THE INSTRUMENT HAS SUFFERED SEVERE TRANSPORT STRESS.

8-46. The following five checks are recommended to verify the product safety of the 4274A LCR Meter (these checks may also be done to check for product safety after troubleshooting and repair). When such checks are needed, perform the following.

1. Visually inspect interior of instrument for any signs of abnormal internally generated heat such as discolored printed circuit boards or components, damaged insulation, or evidence of arcing. Determine and remedy cause of any such condition.
2. Using a suitable ohmmeter, check resistance from instrument enclosure to ground pin on power cord plug. The reading must be less than 0.5 ohm. Flex the power cord while making this measurement to determine whether intermittent discontinuities exist.
3. Check GUARD terminal on front panel using procedure (2).

4. Disconnect instrument from power source. Turn power switch to 'on'. Check resistance from instrument enclosure to line and neutral (tied together). The minimum acceptable resistance is two megohms. Replace any component which fails or causes a failure.
5. Check line fuse to verify that a correctly rated fuse is installed.

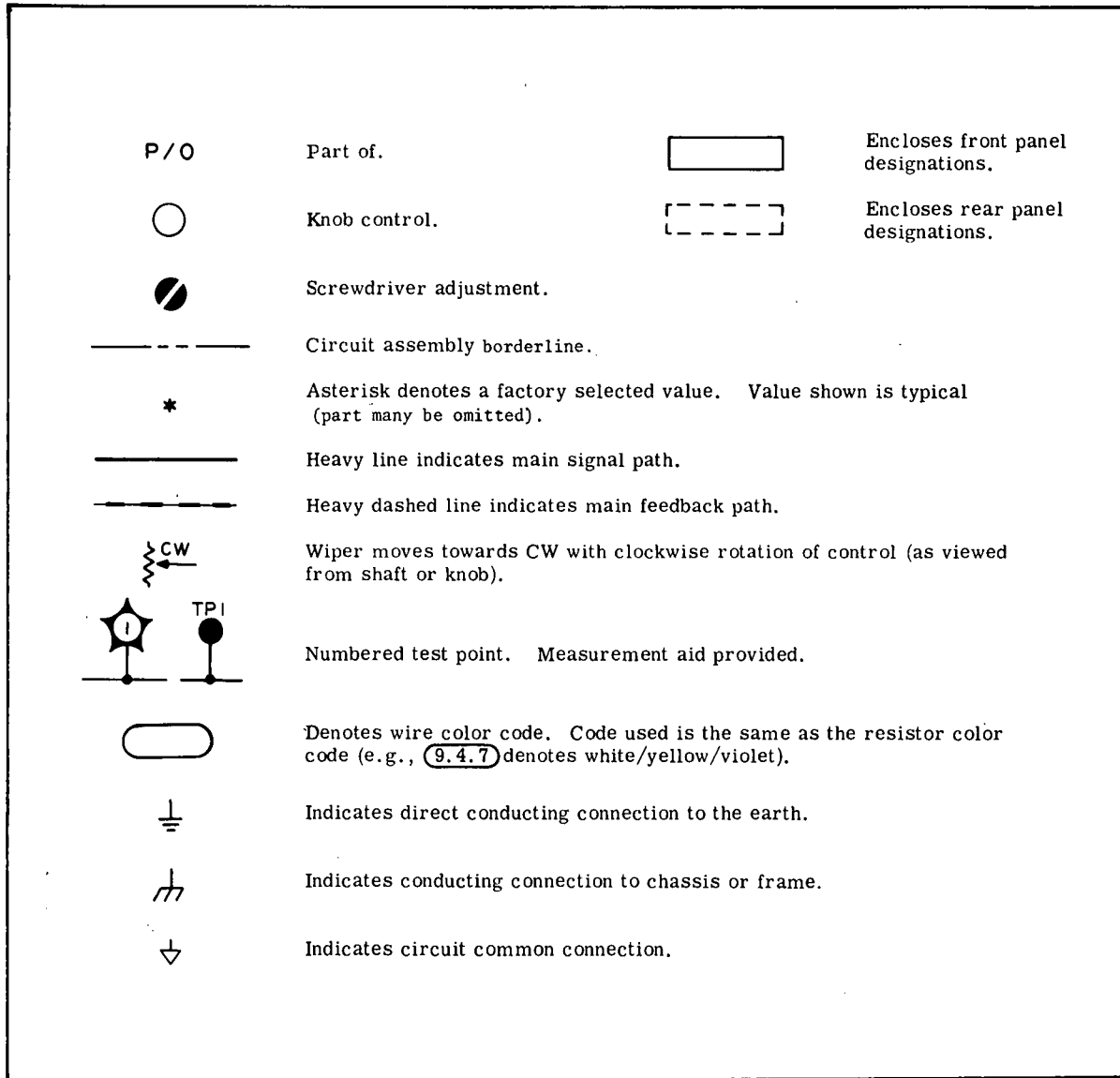

Figure 8-12. Schematic Diagram Notes.

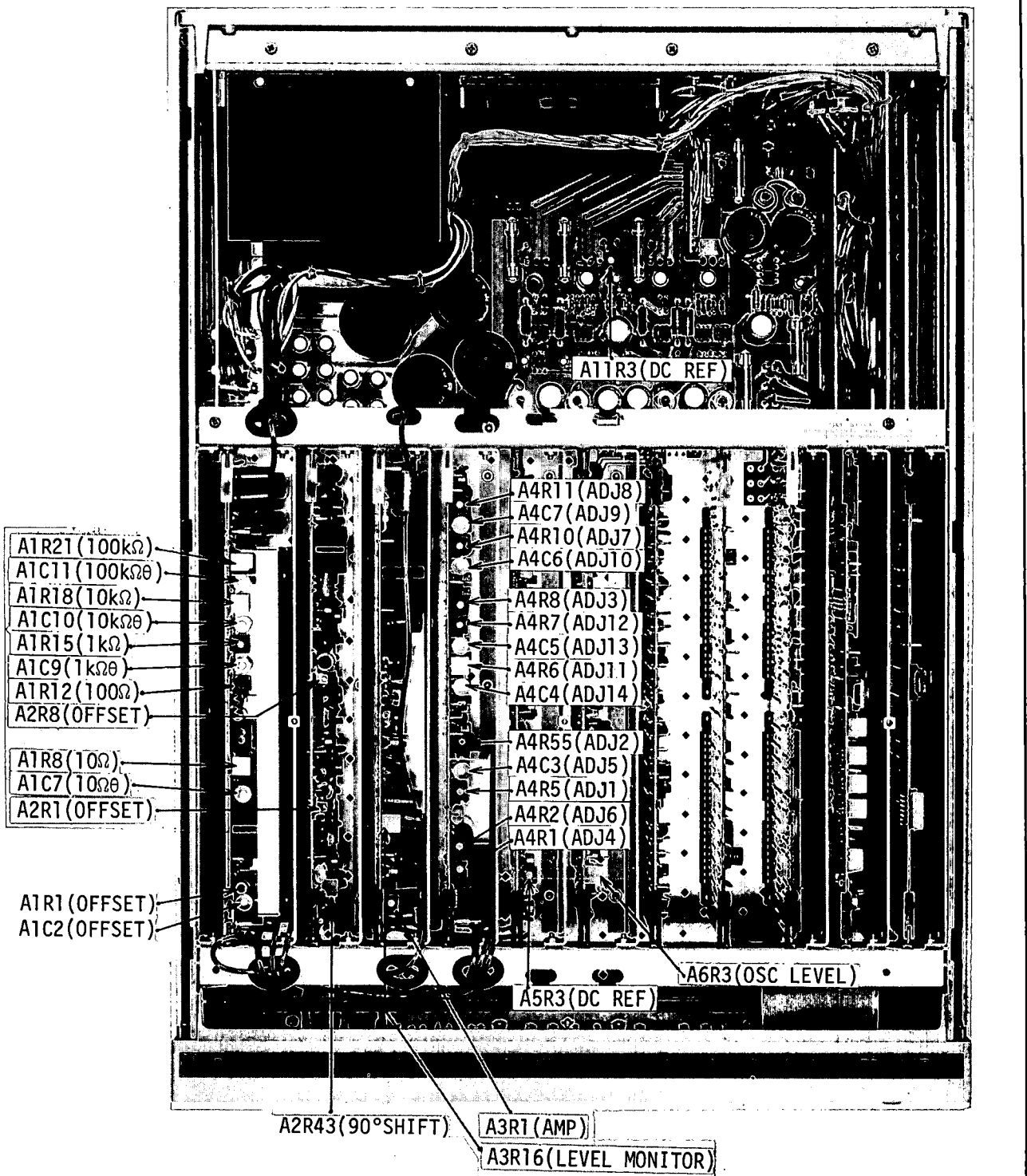

Figure 8-13. Adjustment Location.



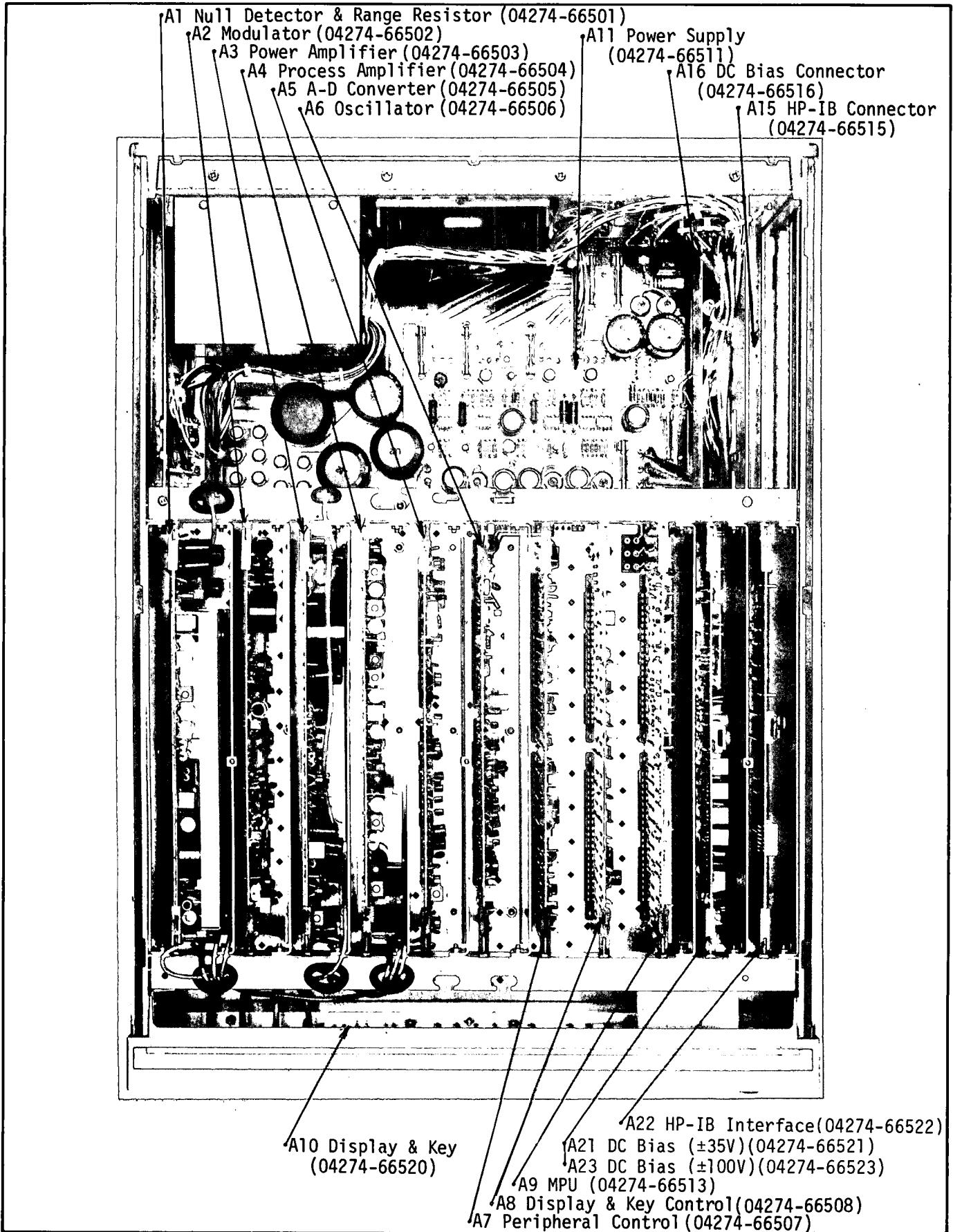

Figure 8-14. Assembly Location.

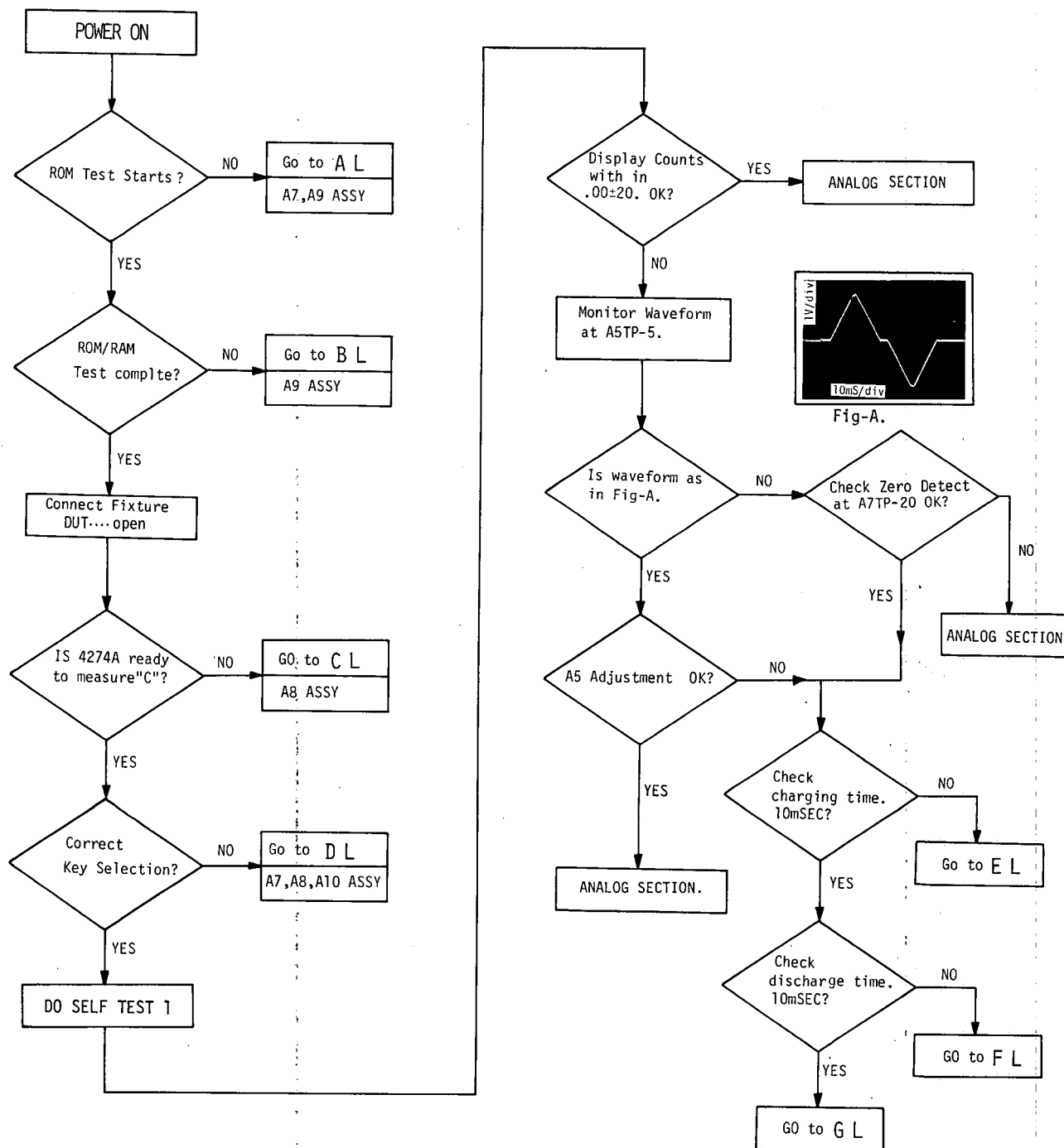

FIGURE 8-15. ANALOG AND DIGITAL SECTIONS ISOLATION FLOW.

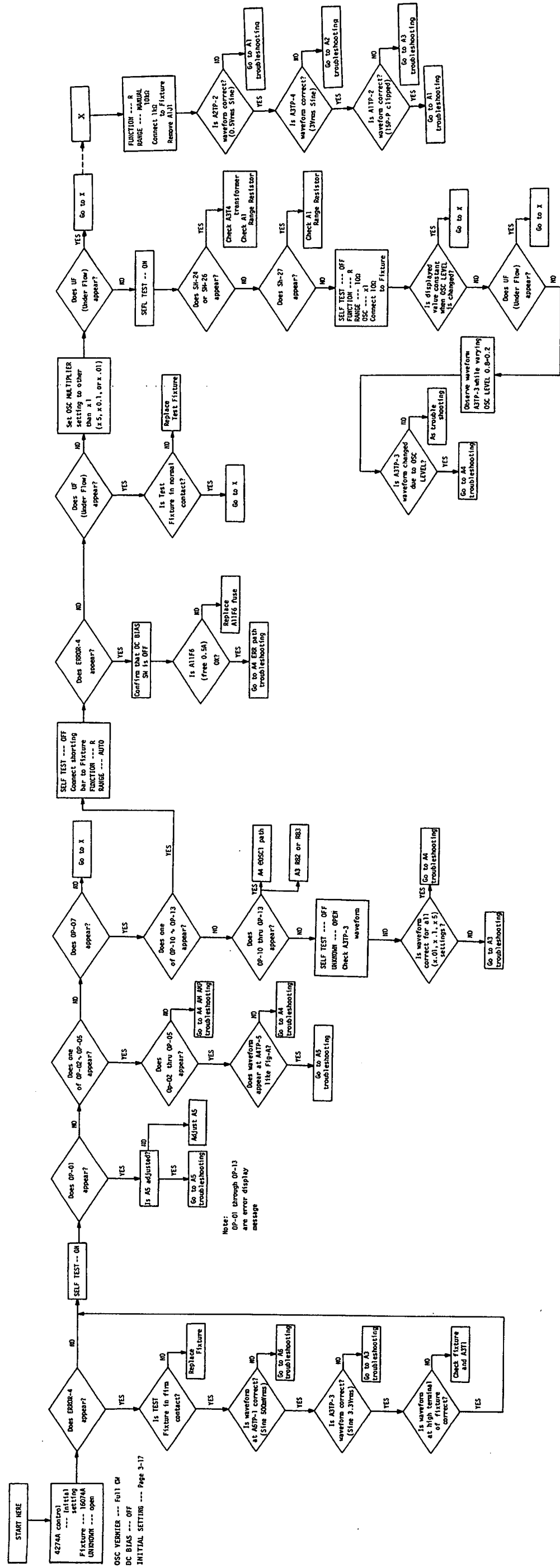

FIGURE 8-16. ANALOG SECTION TROUBLE SHOOTING TO ASSEMBLY LEVEL.

— ANALOG SECTION TROUBLESHOOTING  
TREE TO ASSEMBLY LEVEL

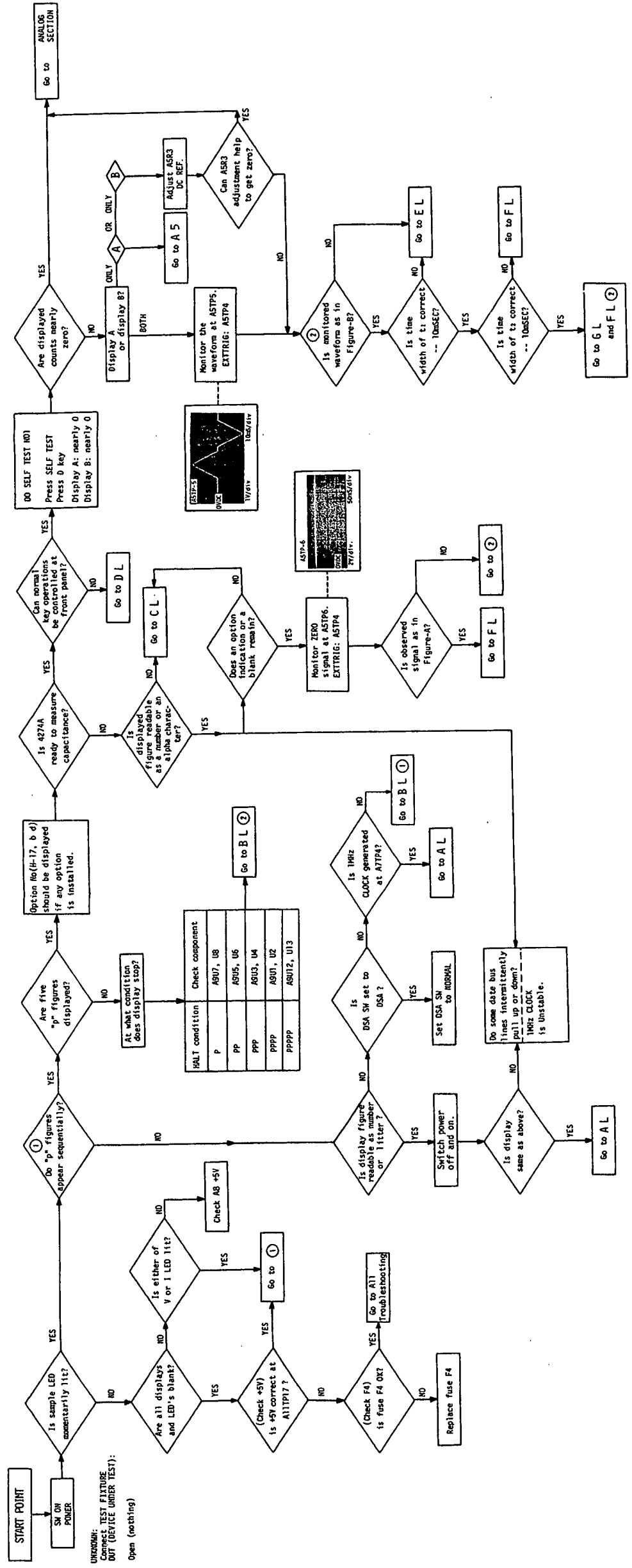

FIGURE 8-17. DIGITAL SECTION TROUBLE SHOOTING TO ASSEMBLY LEVEL. 8-35

← DIGITAL SECTION TROUBLESHOOTING  
TREE TO ASSEMBLY LEVEL

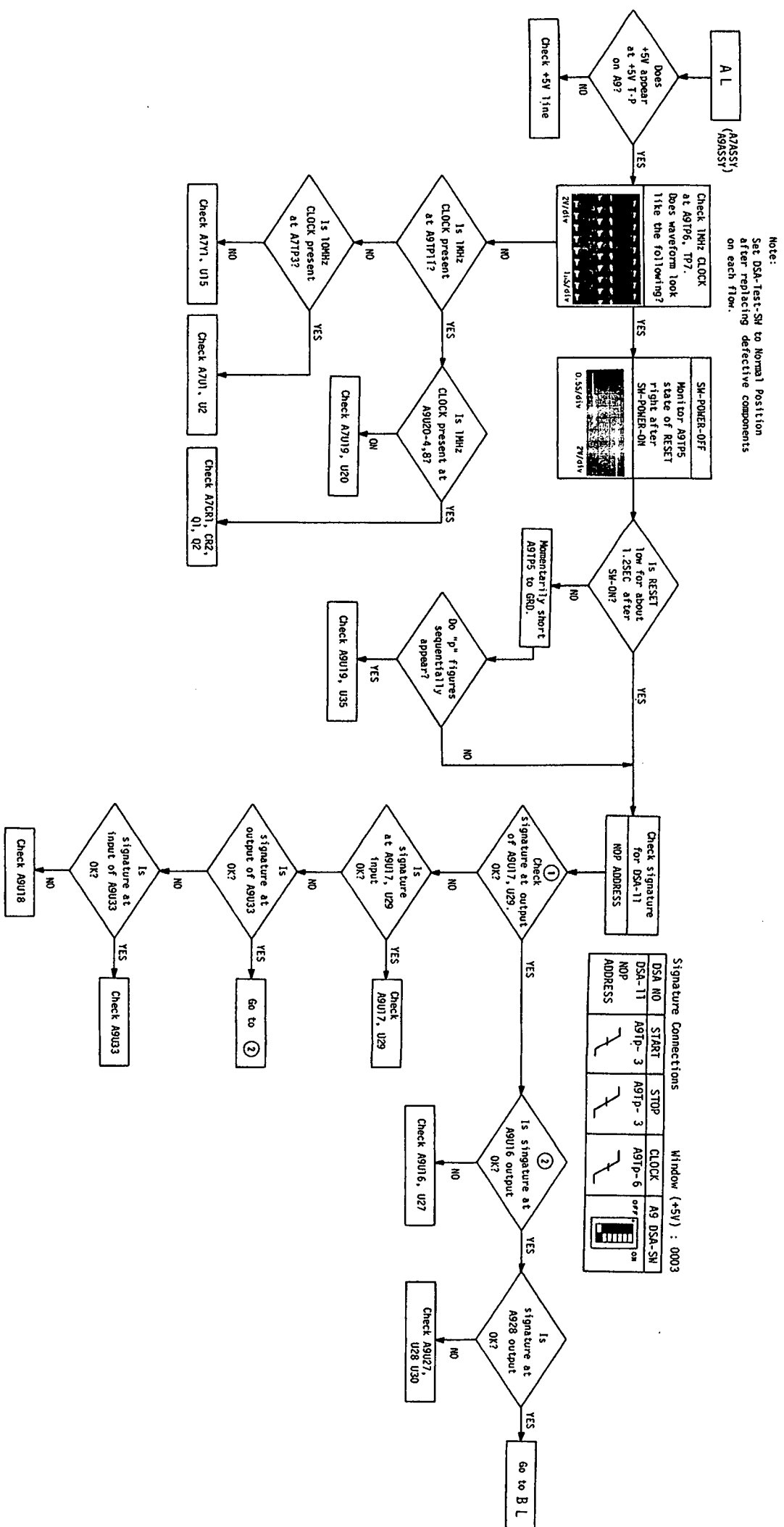

FIGURE 8-18. DIGITAL SECTION TROUBLE SHOOTING FLOW DIAGRAM AL.  
8-37

← AL TROUBLESHOOTING TREE  
UNDER FOLD

This table can be used to check signatures at A9U1 thru A9U10 ROM's. Signature test point is established at input of Data Buffer (pins 8 thru 6 of A9U31 and A9U32) instead of the respective ROM outputs (A9U1 thru A9U10). This signature list can be used for units with its serial number suffixes of -00266 and above.

For other instruments whose serial number suffixes are earlier than 00266, check that unstable signature display appears or that output states of these ROM's pull up and pull down. If you find above states active in earlier instruments, the program contents in these ROM may be alive.

TEST PIN NO	SIGNAL NAME	DSA NAME		DSA-12	DSA-14	DSA-15	DSA-16	DSA-17	DSA-13
		ROM TEST POINT	ROM TEST NO.						
WINDOM(+5V)		U1 pin-24	755U	A9U1 A9U7	A9U1	A9U3	A9U5	A9U7	A9U10
DB0		U31 pin-3	5A83	42P2	P254	P254	P254	P254	826P
DB1		pin-4	FCCP	9949	307F	08CA	86P3	HAUH	
DB2		pin-5	17C6	8UH8	HPF4	9FBF	7HPC	A63F	
DB3		pin-6	283P	P909	379A	CPIU	5H2H	3094	
DB4		U32 pin-3	H6F2	8FU9	2U43	5H23	5A01	565C	
DB5		pin-4	5A48	F854	5410	U899	H1F5	501H	
DB6		pin-5	73F2	6PF8	69HH	89PP	775H	39A1	
DB7		pin-6	7AHA	052P	0P76	FP5F	8PC7	F454	





← BL TROUBLESHOOTING TREE  
UNDER FOLD

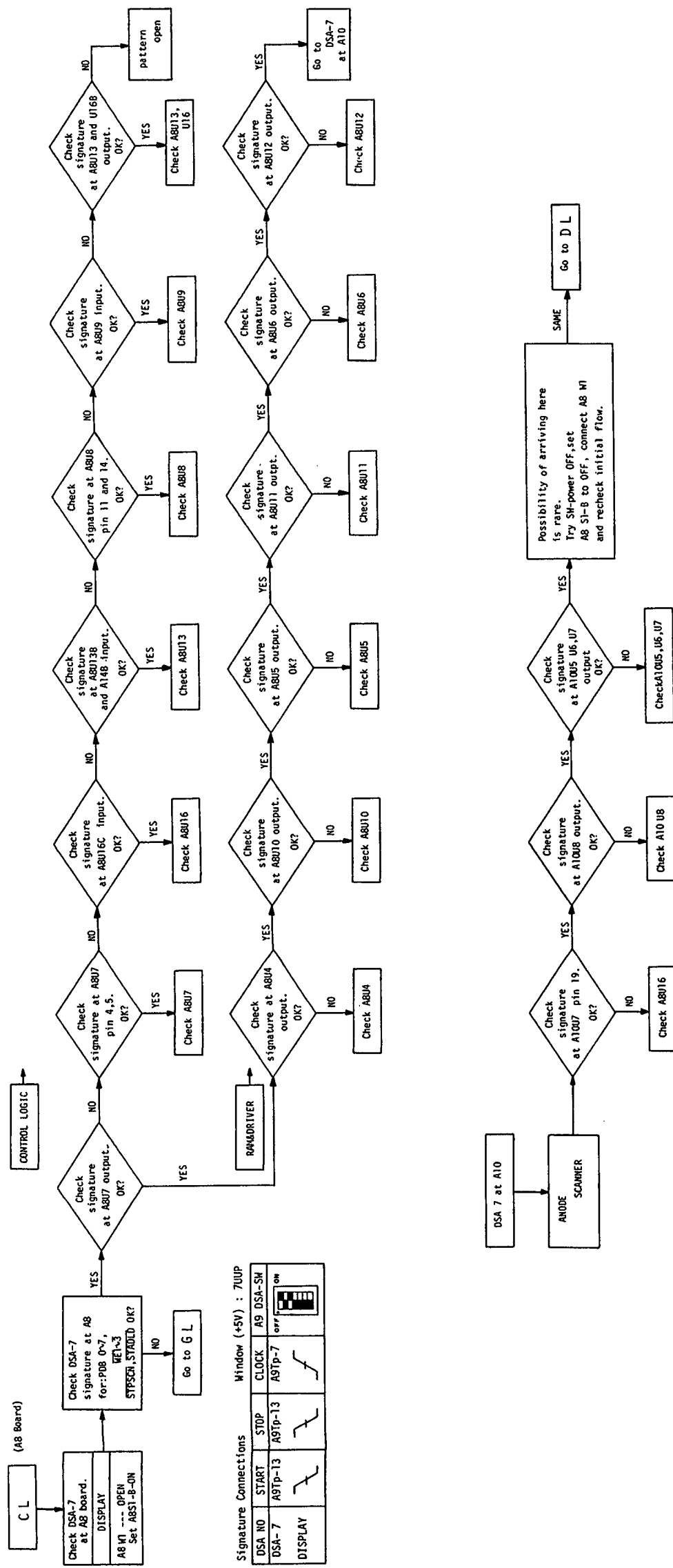

Signature Connections Window (+5V) : 7UUP

DSA NO	START	STOP	CLOCK	A9 DSA-SW
DSA-7	A9Tp-13	A9Tp-13	A9Tp-7	off
DISPLAY				on

FIGURE 8-20. DIGITAL SECTION TROUBLE SHOOTING FLOW DIAGRAM CL, 8-41

← CL TROUBLESHOOTING TREE  
UNDER FOLD

8-41

8-42

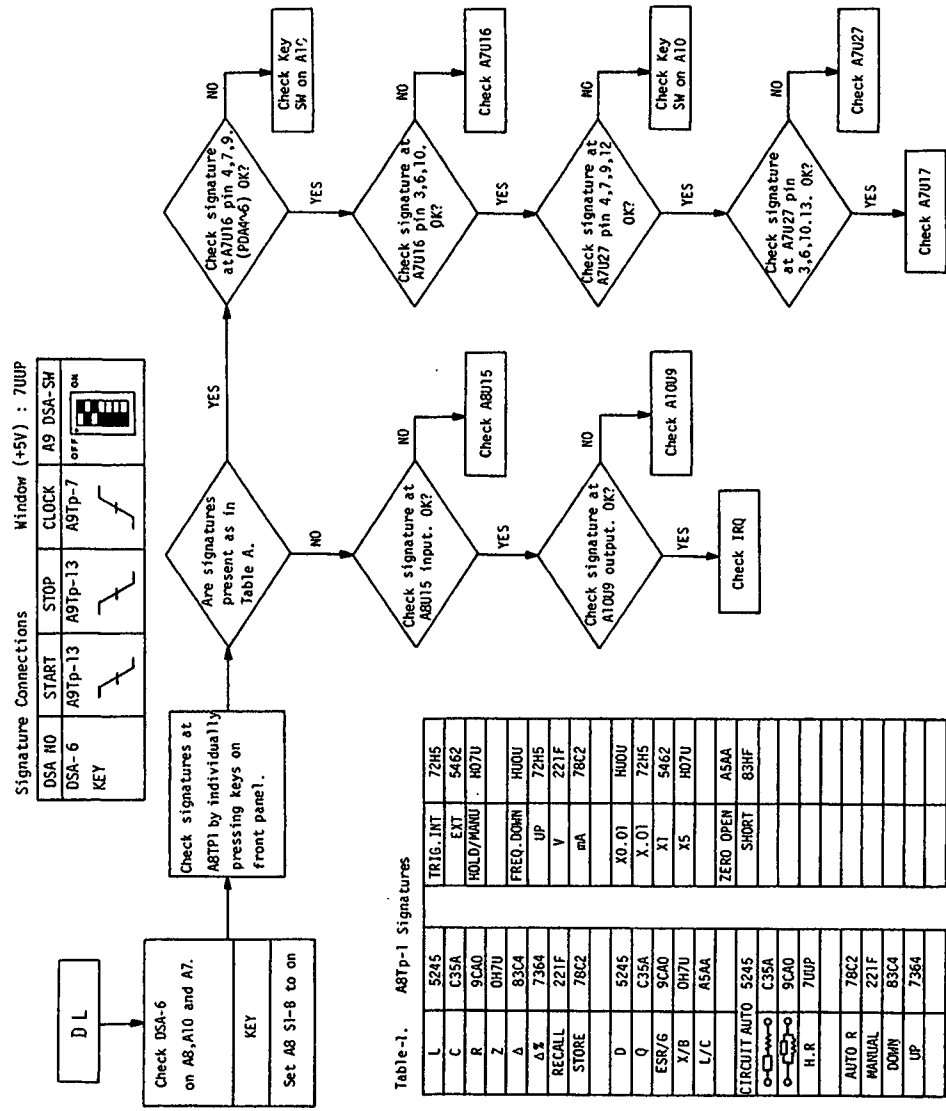

Signature Connections Window (+5V) : 7UUP

DSA NO	START	STOP	CLOCK	A9 DSA-SH
DSA-6 KEY	A9Tp-13	A9Tp-13	A9Tp-7	err on

Table 1. A8Tp-1 Signatures

L	5245	TRIG. INT	72H5
C	C35A	EXT	5462
R	9CA0	HOLD/MANU	HO7U
Z	OH7U		
Δ	83CA	FREQ. DOWN	H0DU
RECALL	221F	UP	72H5
STORE	78C2	V	221F
		mA	78C2
D	5245	X0.01	H0DU
Q	C35A	X.01	72H5
ESR/G	9CA0	X1	5462
X/Y	OH7U	X5	HO7U
L/C	A5AA	ZERO OPEN	A5AA
CIRCUIT AUTO	5245	SHORT	83HF
DOWN	C35A		
UP	9CA0		
H.R	7UUP		
AUTO R	78C2		
MANUAL	221F		
DOWN	83CA		
UP	7364		
SELF.T	7UUP		

Table 2. A10U9 Signatures

Pin	Key	signature	pin	Key	signature
1	SELF TEST	0000	9	STORE	074F
2	L	2HCC	10	Δ	UF4A
3	C	FFA4	11	Δ\$	0F9A
4	R	P45P	14	0.01	A0U1
5	Z	7281	15	0.1	OH2C
6	L/C	H454	16	1	2C9F
7	SHORT	UF22	17	5	AU81
8	RECALL	5HP2			

Table 3. A7U16, U27 Signatures

SIGNAL	TEST PIN	SIGNATURE	TEST PIN	SIGNATURE
PDA 0	U27-4	P48F	U27-3	7686
1	-7	7CAA	-6	H68U
2	-9	1087	-10	7FUF
3	-12	C704	-13	PP7U
4	U16-4	0000	U16-3	PP7U
5	-7	0000	-6	PP7U
6	-9	0000	-10	PP7U

FIGURE 8-21. DIGITAL SECTION TROUBLE SHOOTING FLOW DIAGRAM DL. 8-43

← DL TROUBLESHOOTING TREE  
UNDER FOLD

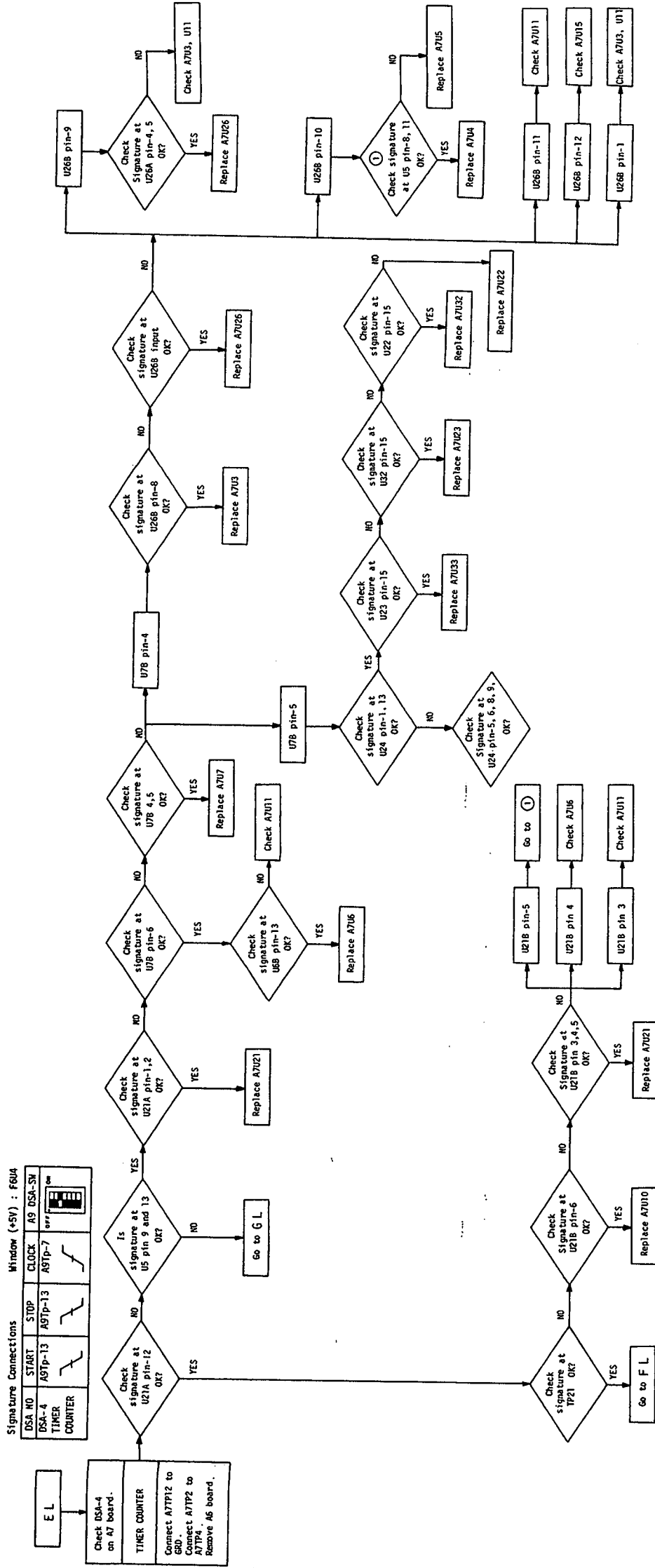

FIGURE 8-22. DIGITAL SECTION TROUBLE SHOOTING FLOW DIAGRAM EL.  
8-45

← EL TROUBLESHOOTING TREE  
UNDER FOLD

8-46

8-45





← FL TROUBLESHOOTING TREE  
UNDER FOLD

8-47

8-48

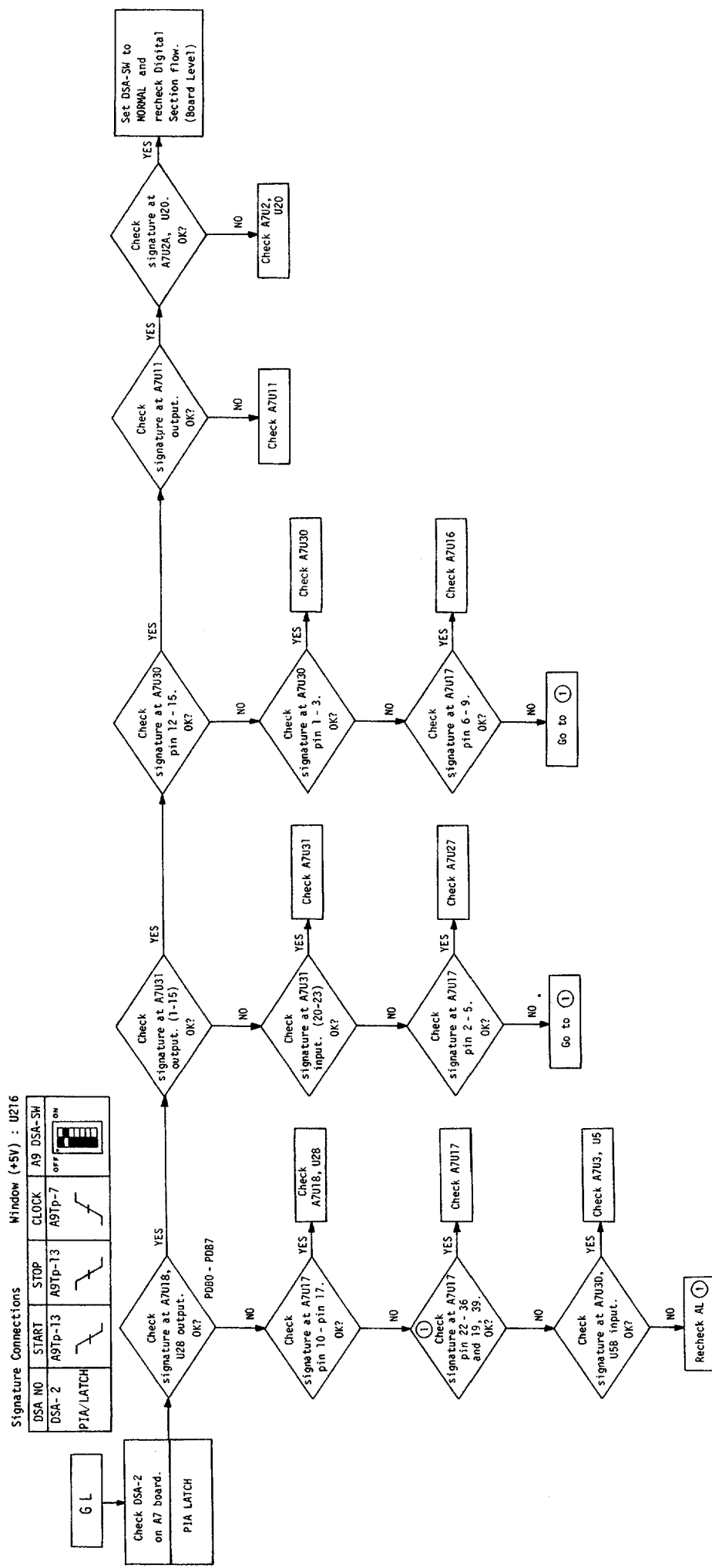

FIGURE 8-24, DIGITAL SECTION TROUBLE SHOOTING FLOW DIAGRAM GL, 8-49

← 6L TROUBLESHOOTING TREE  
UNDER FOLD

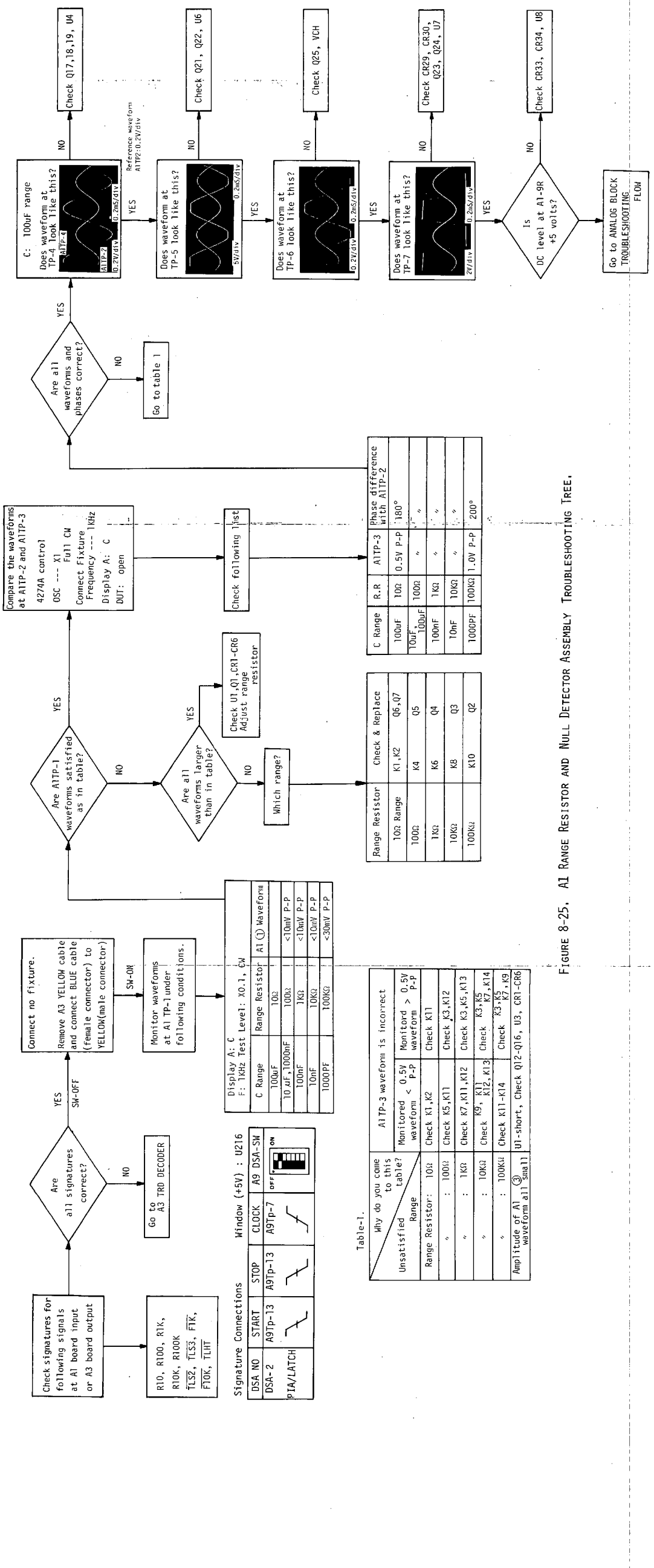

FIGURE 8-25. A1 RANGE RESISTOR AND NULL DETECTOR ASSEMBLY TROUBLESHOOTING TREE.

A1 TROUBLESHOOTING TREE  
UNDER FOLD →

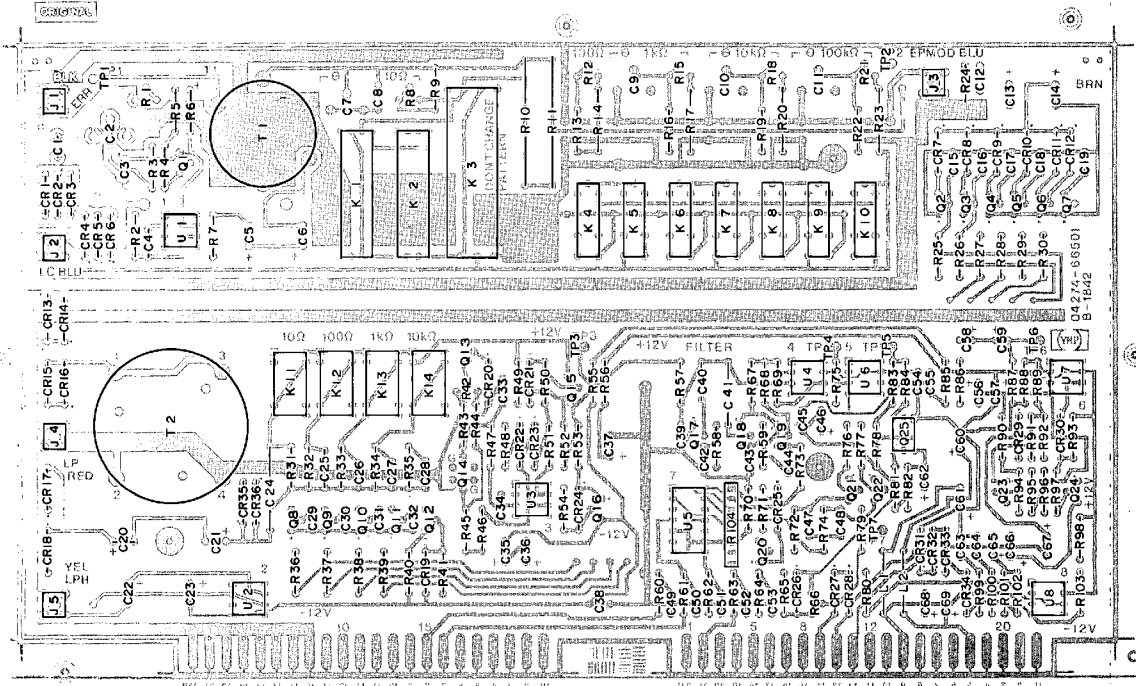

FIGURE 8-26. AI RANGE RESISTOR AND NULL DETECTOR ASSEMBLY COMPONENT LOCATION.

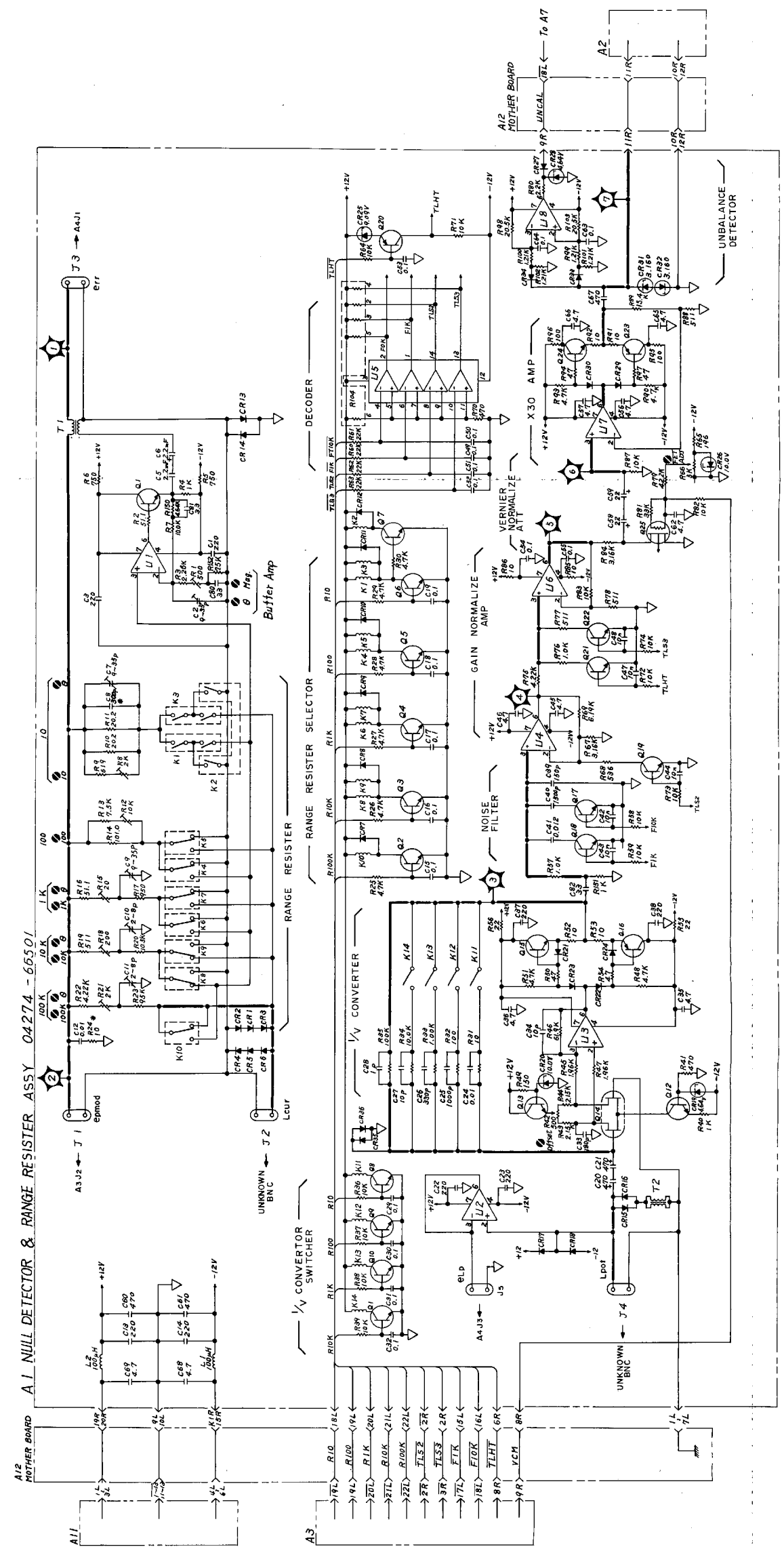

FIGURE 8-27. AI RANGE RESISTOR AND NULL DETECTOR ASSEMBLY SCHEMATIC DIAGRAM.

A2 TROUBLESHOOTING TREE  
UNDER FOLD

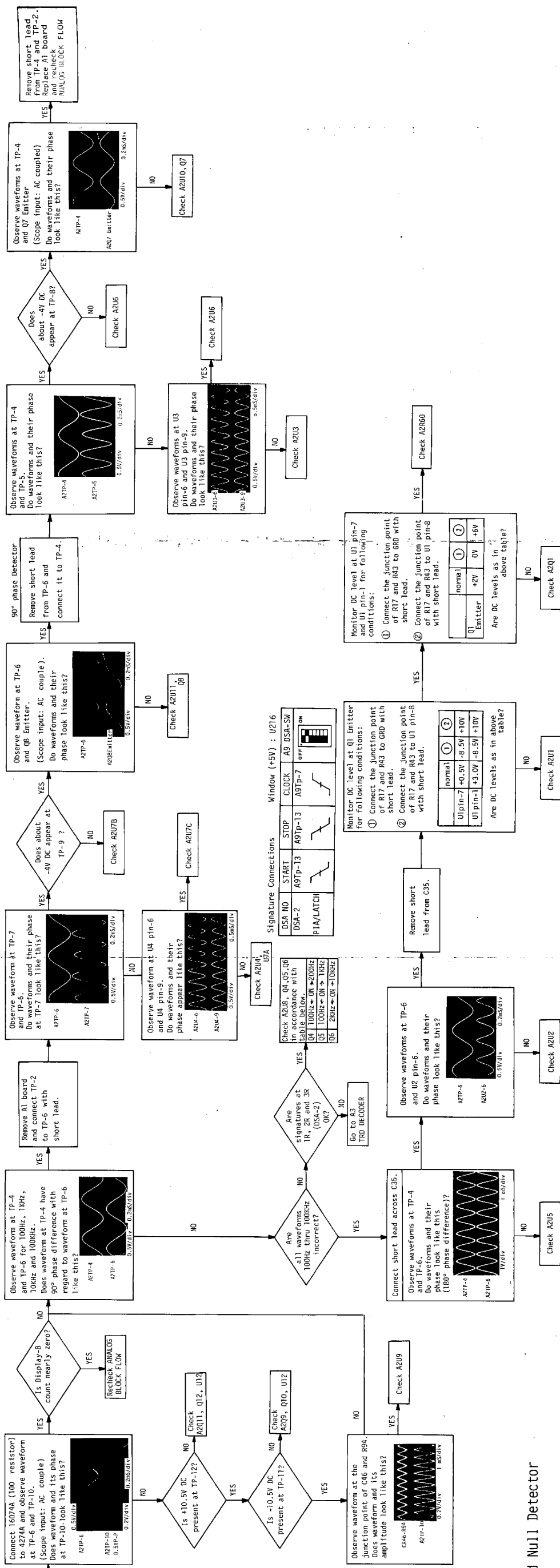

FIGURE 8-28. A2 MODULATOR ASSEMBLY TROUBLESHOOTING TREE.

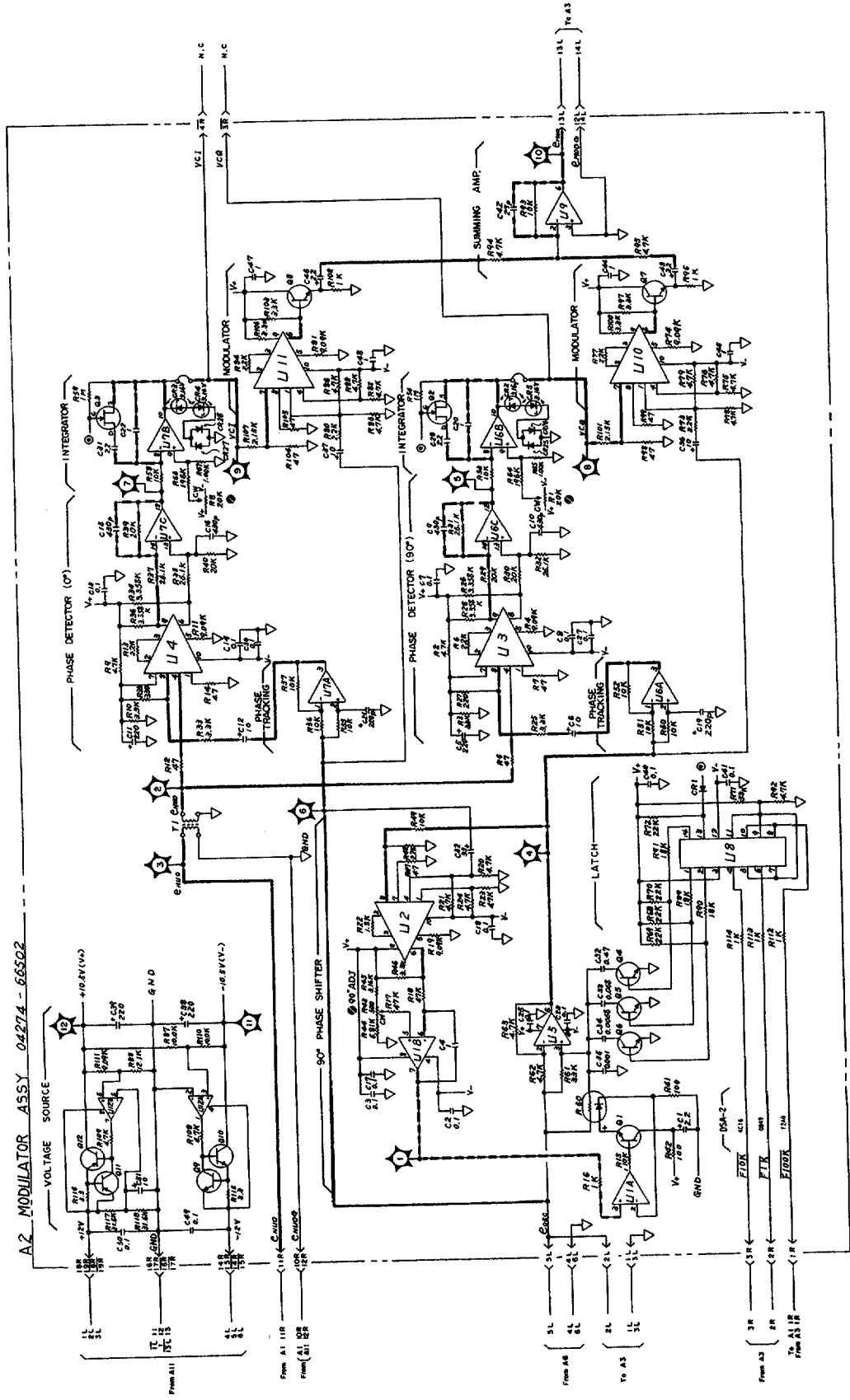

FIGURE 8-30. A2 MODULATOR ASSEMBLY SCHEMATIC DIAGRAM, 8-53

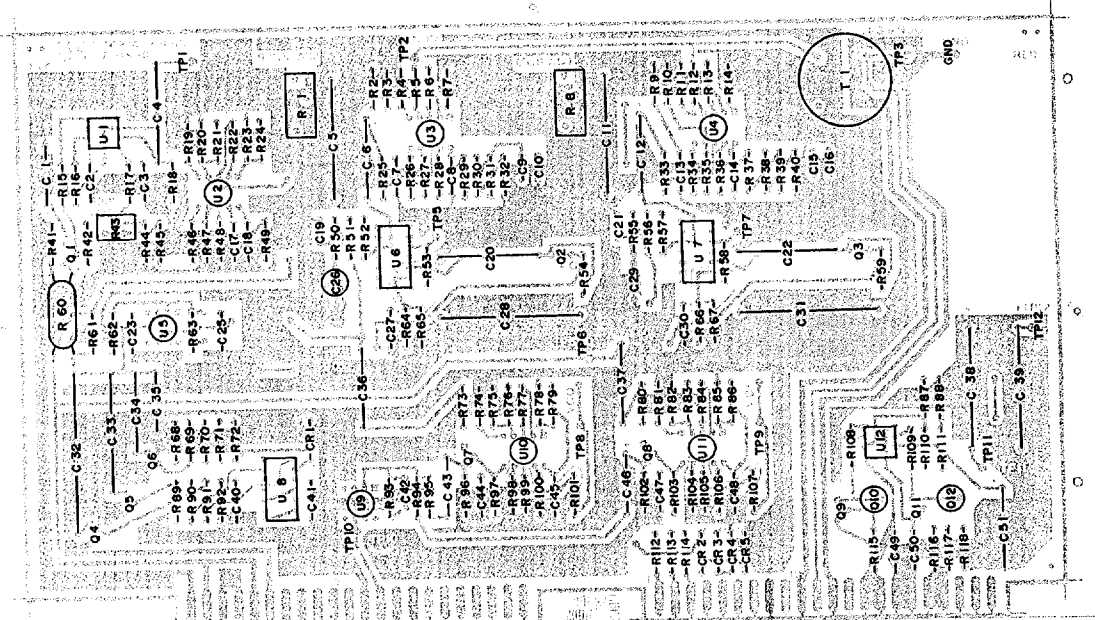

FIGURE 8-29. A2 MODULATOR ASSEMBLY COMPONENT LOCATIONS.

A3 TROUBLESHOOTING TREE  
UNDER FOLD

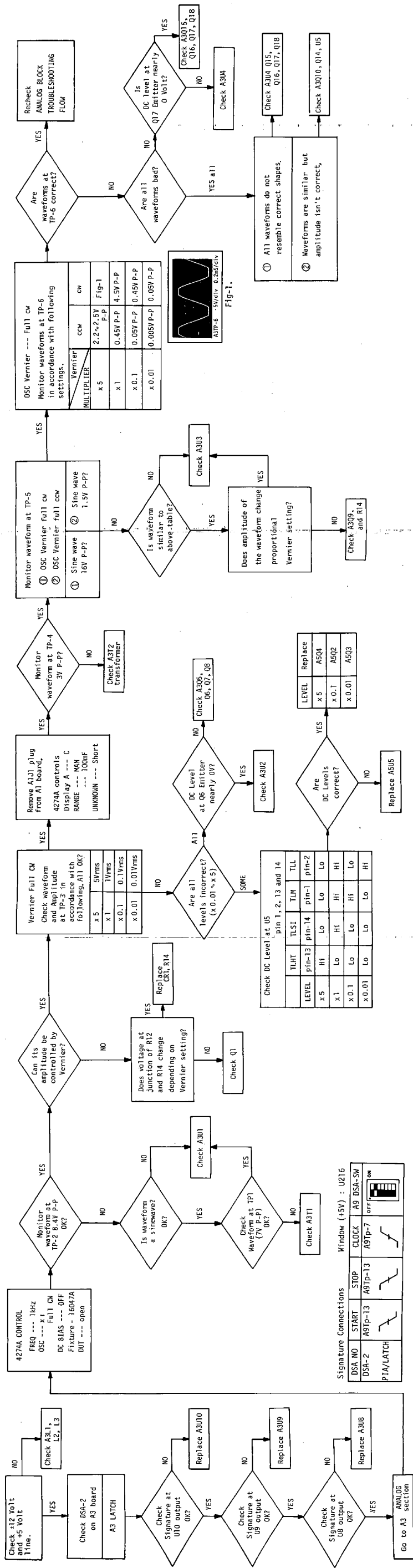

FIGURE 8-31. A3 POWER AMPLIFIER ASSEMBLY TROUBLESHOOTING TREE.



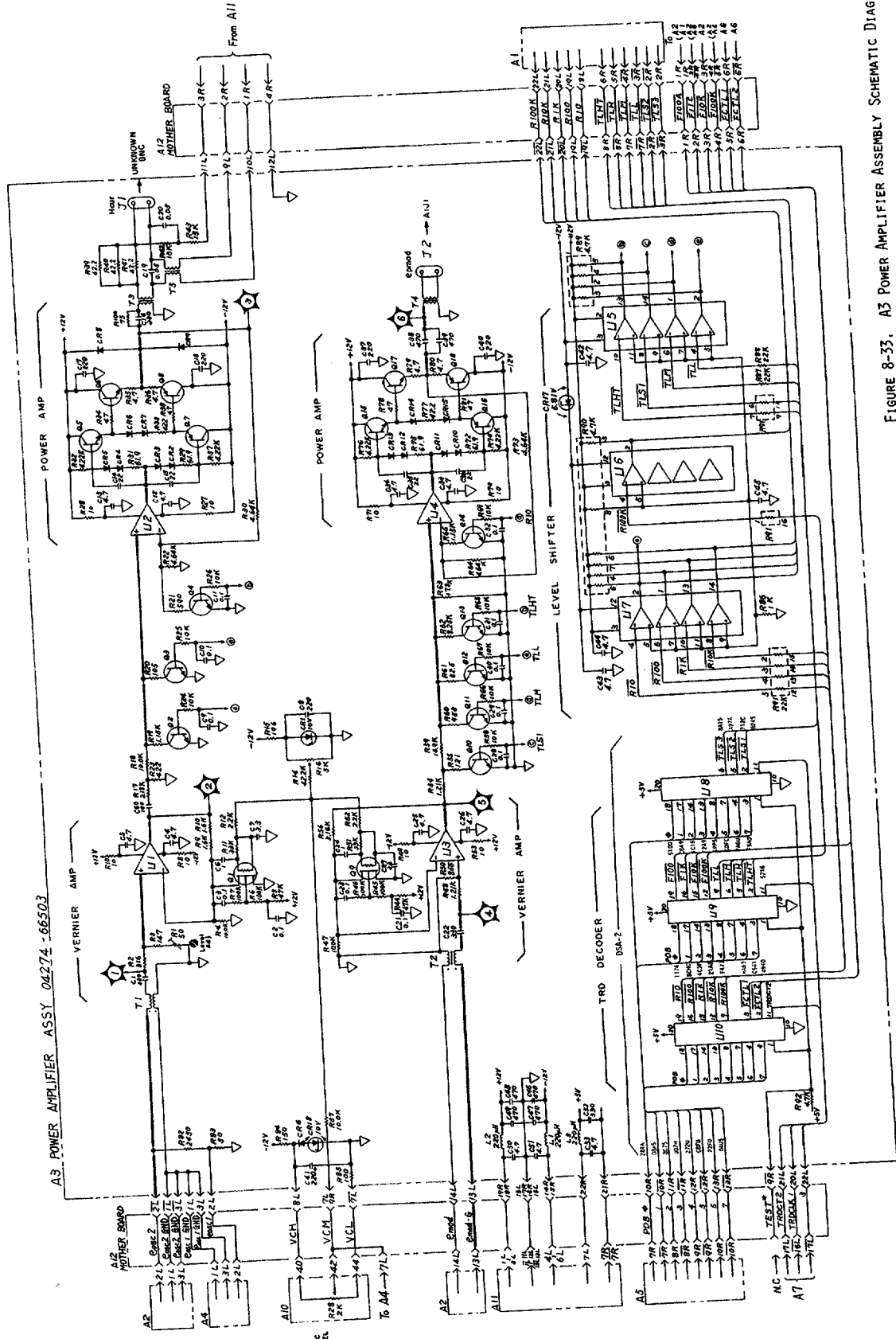

FIGURE 8-33. A3 POWER AMPLIFIER ASSEMBLY SCHEMATIC DIAGRAM. 8-55

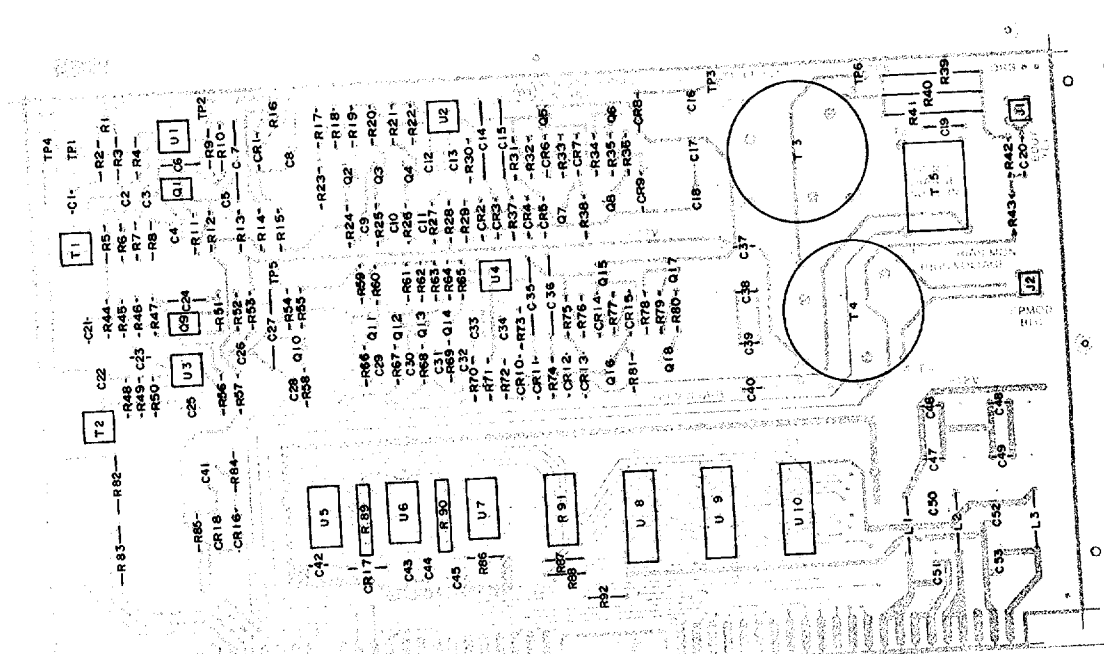

FIGURE 8-32. A3 POWER AMPLIFIER ASSEMBLY COMPONENT LOCATIONS.

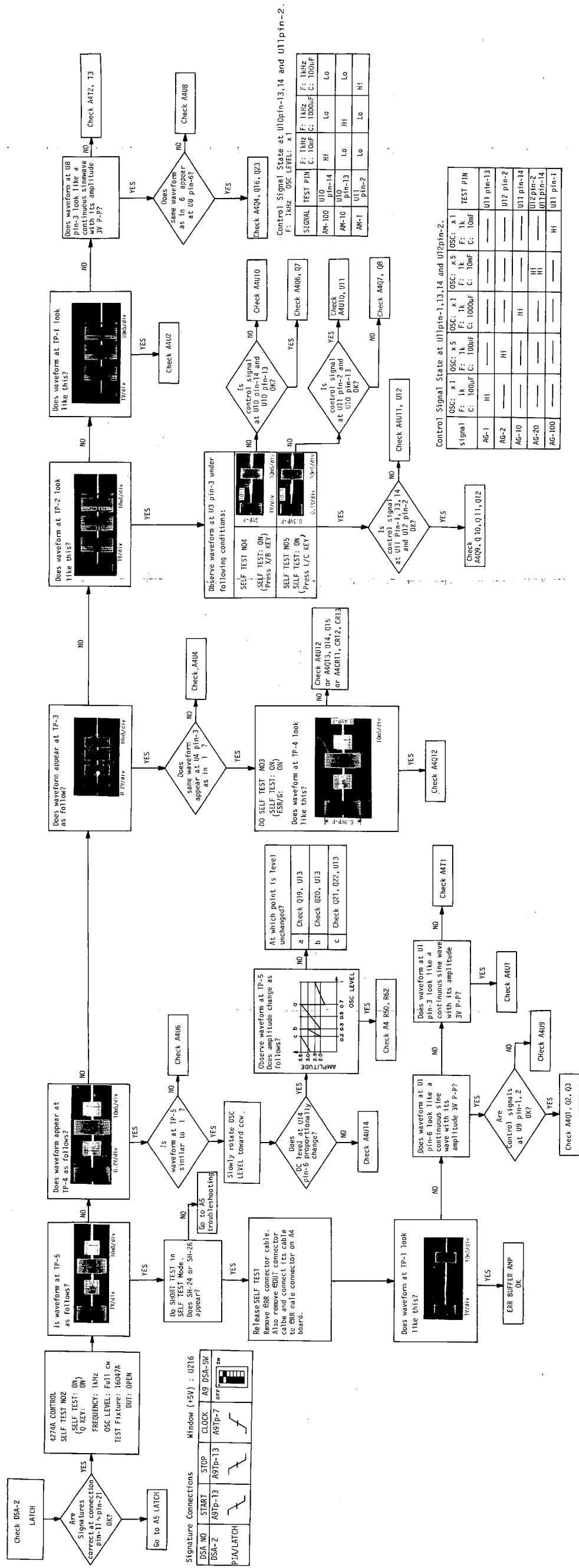

FIGURE 8-34. A4 PROCESS AMPLIFIER ASSEMBLY TROUBLESHOOTING TREE.





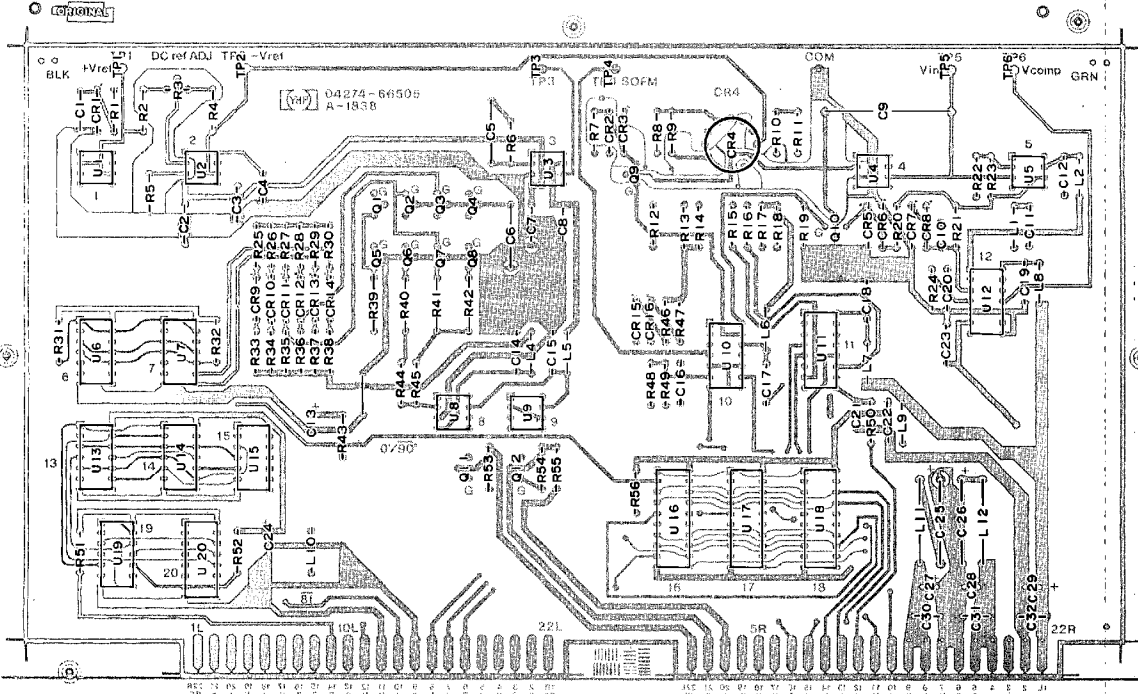

FIGURE 8-38. A5 A-D CONVERTER ASSEMBLY COMPONENT LOCATIONS

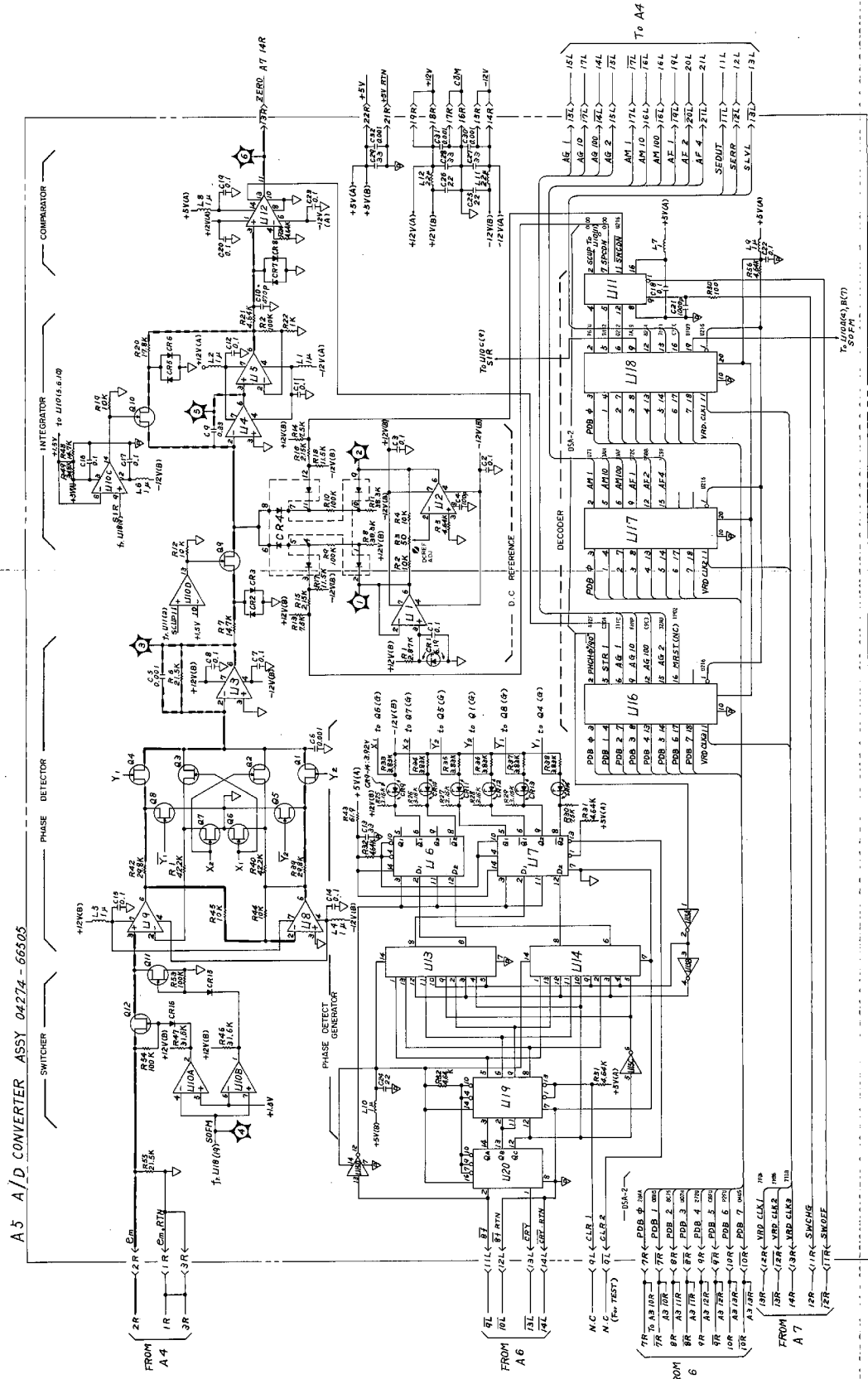

FIGURE 8-39. A5 A-D CONVERTER ASSEMBLY SCHEMATIC DIAGRAM.

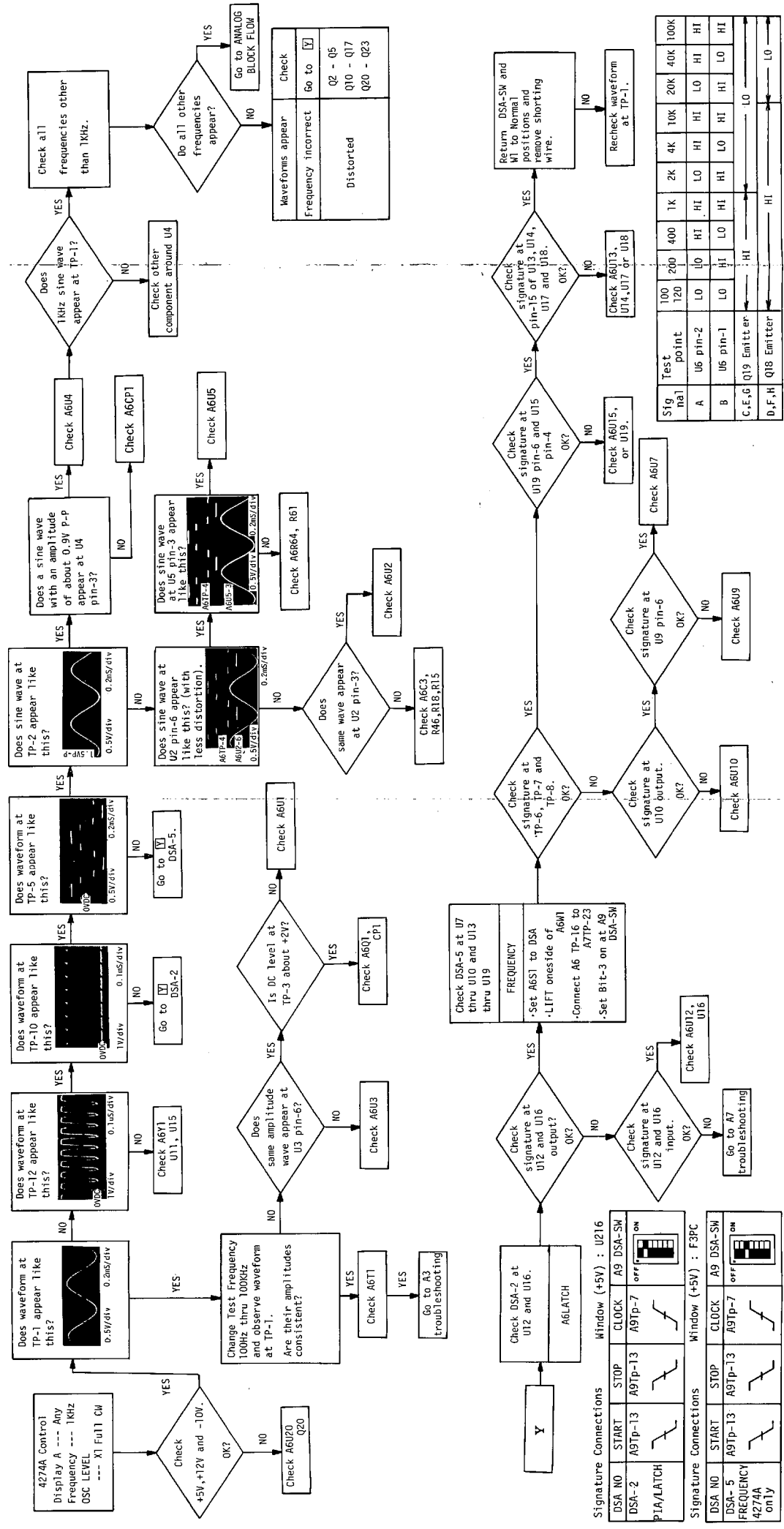

FIGURE 8-40. A6 OSCILLATOR ASSEMBLY TROUBLESHOOTING TREE.

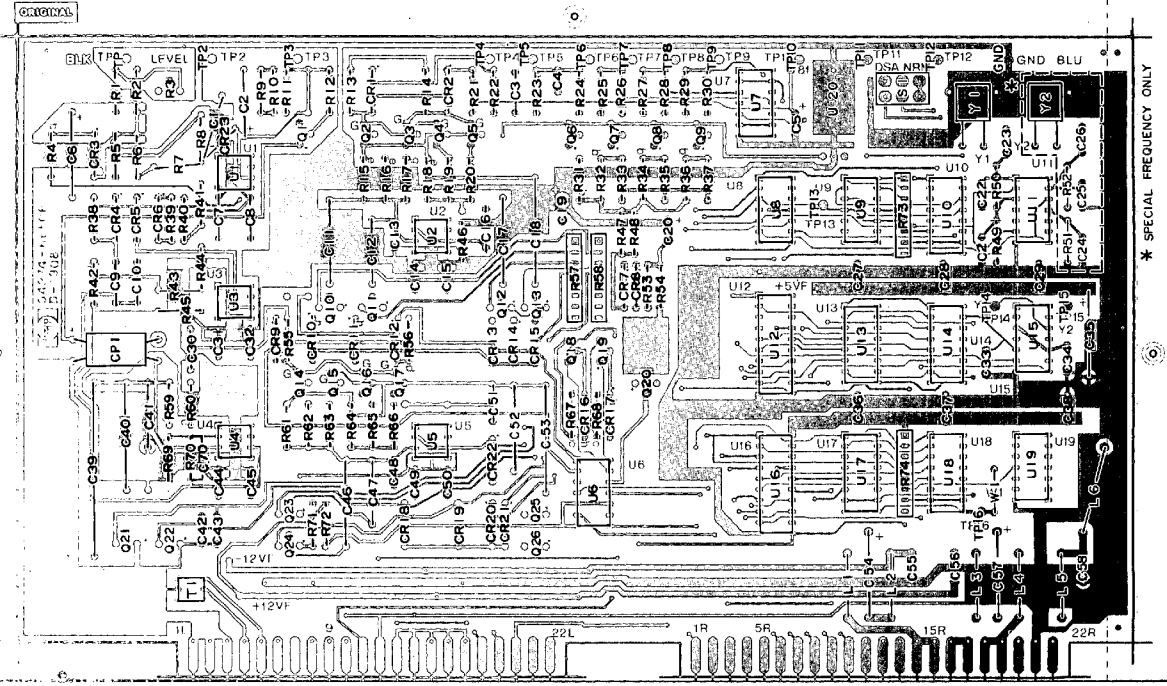

FIGURE 8-41. A6 OSCILLATOR ASSEMBLY COMPONENT LOCATIONS.

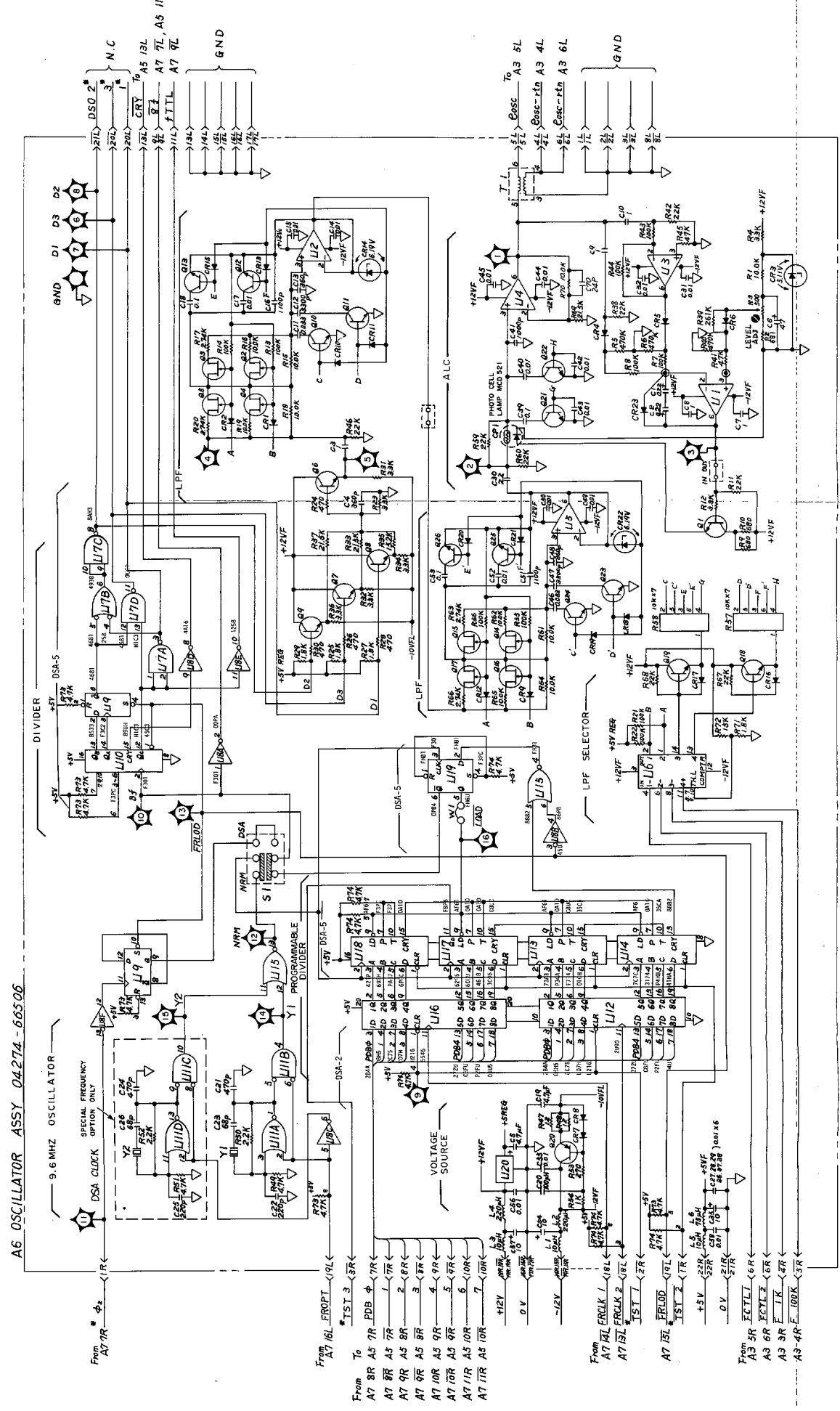

FIGURE 8-42. A6 OSCILLATOR ASSEMBLY SCHEMATIC DIAGRAM.

Signature Connections Window (+5V) : U216

DSA NO	START	STOP	CLOCK	A9 DSA-SW
DSA-2	A9Tp-13	A9Tp-13	A9Tp-7	off on
PIA/LATCH				

Signature Connections Window (+5V) : H1UR

DSA NO	START	STOP	CLOCK	A9 DSA-SW
DSA-3	A9Tp-13	A9Tp-13	A9Tp-7	off on

Other Setting:  
 Remove A6 ASSY.  
 Connect TP12 to GRD with shorting clip.  
 Connect TP20 to TP23 with shorting clip.  
 Remove A7W4 one side.

Signature Connections Window (+5V) : 8COA

DSA NO	START	STOP	CLOCK	A9 DSA-SW
DSA-4	A9Tp-13	A9Tp-13	A9Tp-7	off on
TIMER COUNTER				

Other Settings:  
 Remove A6 ASSY.  
 Connect TP12 to GRD with shorting clip.  
 Connect A7TP2 to A7TP4 with shorting clip.



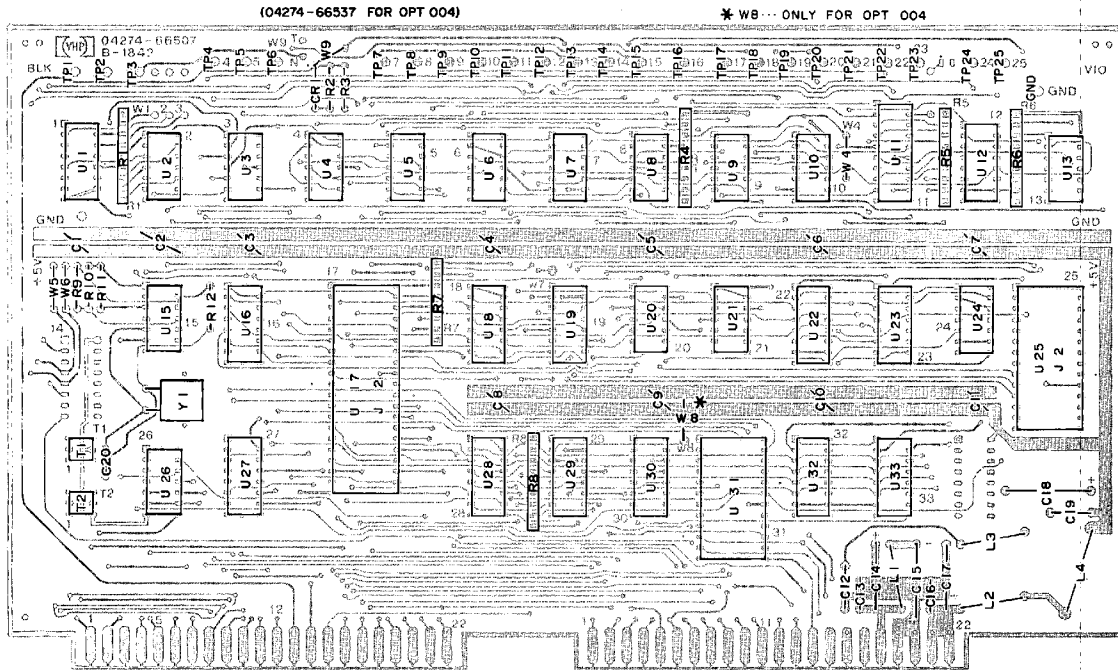

FIGURE 8-43. A7 PERIPHERAL CONTROL ASSEMBLY COMPONENT LOCATIONS.

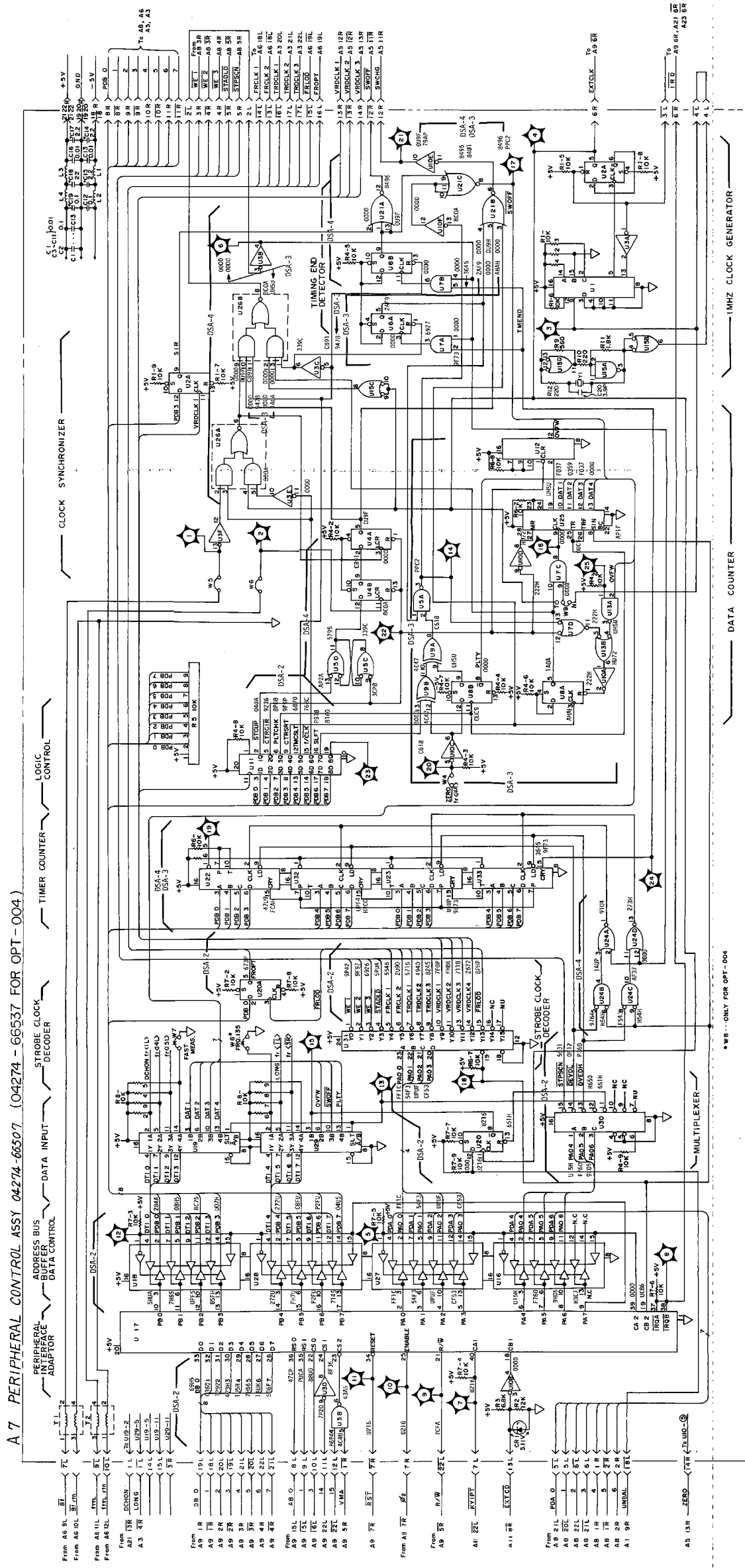



FIGURE 8-44. A7 PERIPHERAL CONTROL ASSEMBLY SCHEMATIC DIAGRAM.

Signature Connections Window (+5V) : 7UUP

DSA NO	START	STOP	CLOCK	A9 DSA-SM
DSA-6	A9Tp-13	A9Tp-13	A9Tp-7	err
KEY				

Other settings:  
Set ABS1-B switch to ON.  
Observe respective signatures at A8Tp1  
for every key on Front panel (push in turn).

Signature Connections Window (+5V) : 7UUP

DSA NO	START	STOP	CLOCK	A9 DSA-SM
DSA-7	A9Tp-13	A9Tp-13	A9Tp-7	err
DISPLAY				

Other Settings:  
Set ABS1-B switch to ON.  
Disconnect one side of ABS1.

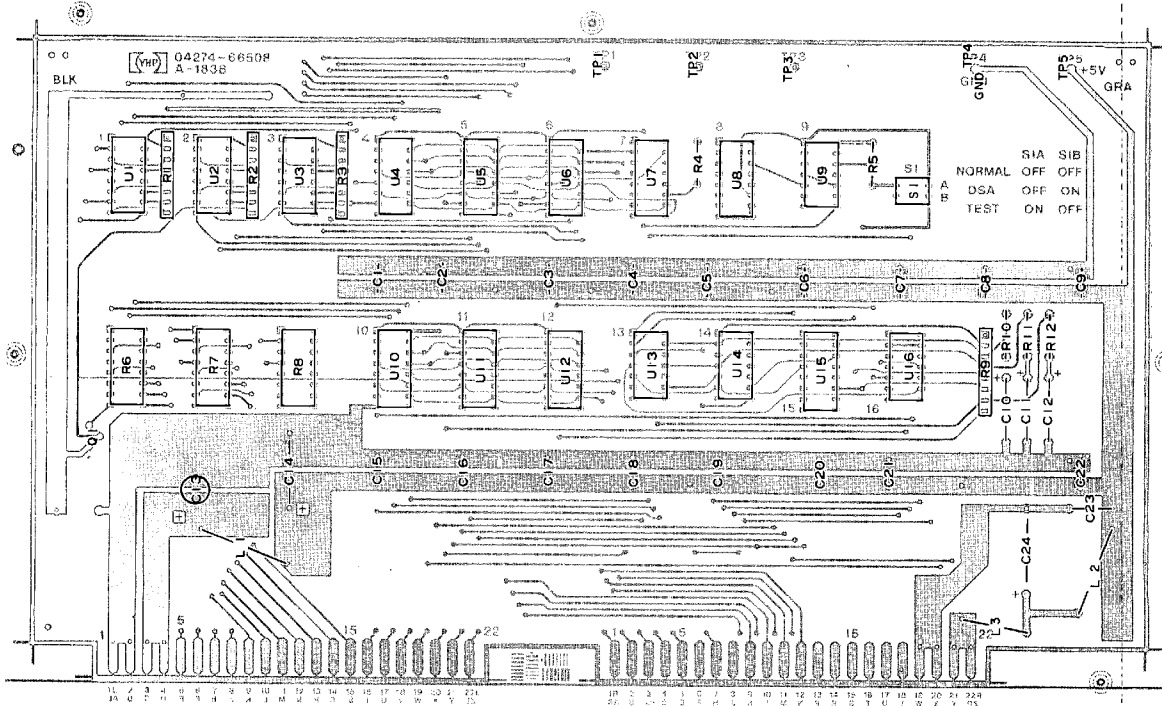

FIGURE 8-45. A8 DISPLAY CONTROL ASSEMBLY COMPONENT LOCATIONS.

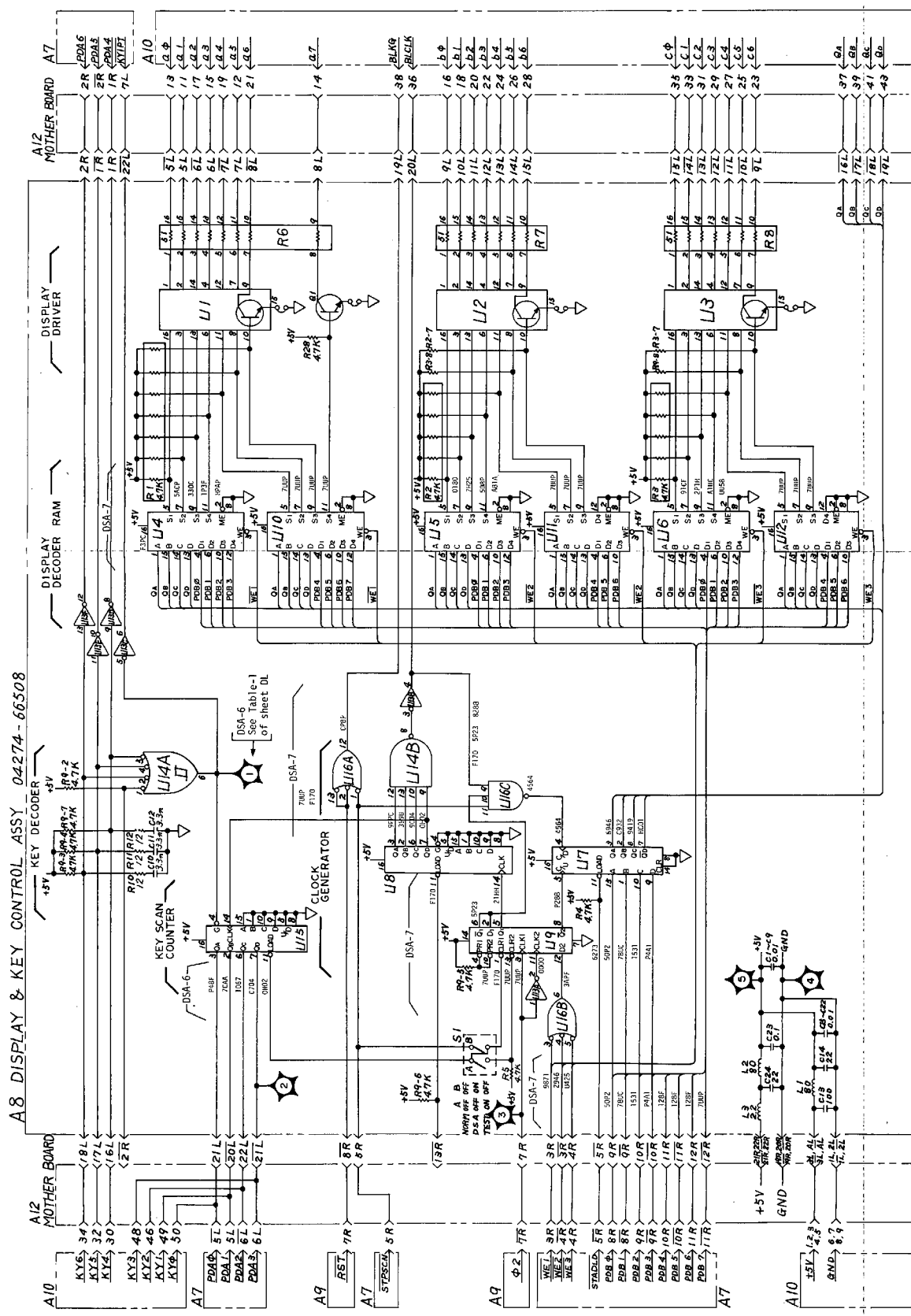

FIGURE 8-46. A8 DISPLAY CONTROL ASSEMBLY SCHEMATIC DIAGRAM.

This table can be used to check signatures at A9U1 thru A9U10 ROM's. Signature test point is established at input of Data Buffer (pins 8 thru 6 of A9U31 and A9U32) instead of the respective ROM outputs (A9U1 thru A9U10). This signature list can be used for units with its serial number suffixes of -00266 and above.

For other instruments whose serial number suffixes are earlier than 00266, check that unstable signature display appears or that output states of these ROM's pull up and pull down. If you find above states active in earlier instruments, the program contents in these ROM may be alive.

TEST PIN NO	SIGNAL NAME	DSA NAME		DSA-12	DSA-14	DSA-15	DSA-16	DSA-17	DSA-13
		ROM TEST POINT	TEST NO.						
DB0	WINDOW(+5V)	U1	pin-24	A9U1	A9U1	A9U3	A9U5	A9U7	A9U10
DB1		U31	pin-3	755U	P254	P254	P254	P254	826P
DB2			pin-4	FCCP	9949	307F	08CA	86P3	HAUH
DB3			pin-5	17C6	8UHB	HPF4	9FBF	7HPC	A63F
DB4			pin-6	283P	P909	379A	CPIU	5H2H	3094
DB5			U32 pin-3	H6F2	8FU9	2U43	5H23	5A01	565C
DB6			pin-4	5A48	F854	5410	U899	H1F5	501H
DB7			pin-5	73F2	6PF8	69HH	89PP	775H	39A1
			pin-6	7AHA	052P	0P76	FP5F	8PC7	F454

Signature Connections			Window (+5V): CCC3			Window (+5V): P254		
DSA NO	START	STOP	CLOCK	A9 DSA-SW	CLOCK	A9 DSA-SW	CLOCK	A9 DSA-SW
DSA-10	A9Tp-13	A9Tp-13	A9Tp-7	on	A9Tp-10	A9Tp-7	A9Tp-6	off
IRQ								
DSA NO	START	STOP	CLOCK	A9 DSA-SW	CLOCK	A9 DSA-SW	CLOCK	A9 DSA-SW
DSA-14	A9U16-10	A9U16-7	A9Tp-6	on	A9U16-10	A9U16-7	A9Tp-6	off
NOP (U1)								

Signature Connections			Window (+5V): 0003			Window (+5V): P254		
DSA NO	START	STOP	CLOCK	A9 DSA-SW	CLOCK	A9 DSA-SW	CLOCK	A9 DSA-SW
DSA-11	A9Tp-3	A9Tp-3	A9Tp-6	on	A9U16-10	A9U16-7	A9Tp-6	off
NOP ADDRESS								
DSA NO	START	STOP	CLOCK	A9 DSA-SW	CLOCK	A9 DSA-SW	CLOCK	A9 DSA-SW
DSA-15	A9U16-10	A9U16-7	A9Tp-6	on	A9U16-10	A9U16-7	A9Tp-6	off
NOP (U3)								

Signature Connections			Window (+5V): 755U			Window (+5V): P254		
DSA NO	START	STOP	CLOCK	A9 DSA-SW	CLOCK	A9 DSA-SW	CLOCK	A9 DSA-SW
DSA-12	A9U27-11	A9U16-5	A9Tp-6	on	A9U16-10	A9U16-7	A9Tp-6	off
NOP (U1, U3, U5, U7)								
DSA NO	START	STOP	CLOCK	A9 DSA-SW	CLOCK	A9 DSA-SW	CLOCK	A9 DSA-SW
DSA-16	A9U16-12	A9U16-10	A9Tp-6	on	A9U16-10	A9U16-7	A9Tp-6	off
NOP (U5)								

Signature Connections			Window (+5V): 826P			Window (+5V): P254		
DSA NO	START	STOP	CLOCK	A9 DSA-SW	CLOCK	A9 DSA-SW	CLOCK	A9 DSA-SW
DSA-13	A9U22-9	A9U10-20	A9Tp-6	on	A9U16-14	A9U16-12	A9Tp-6	off
NOP (U10)								
DSA NO	START	STOP	CLOCK	A9 DSA-SW	CLOCK	A9 DSA-SW	CLOCK	A9 DSA-SW
DSA-17	A9U16-14	A9U16-12	A9Tp-6	on	A9U16-10	A9U16-7	A9Tp-6	off
NOP (U7)								

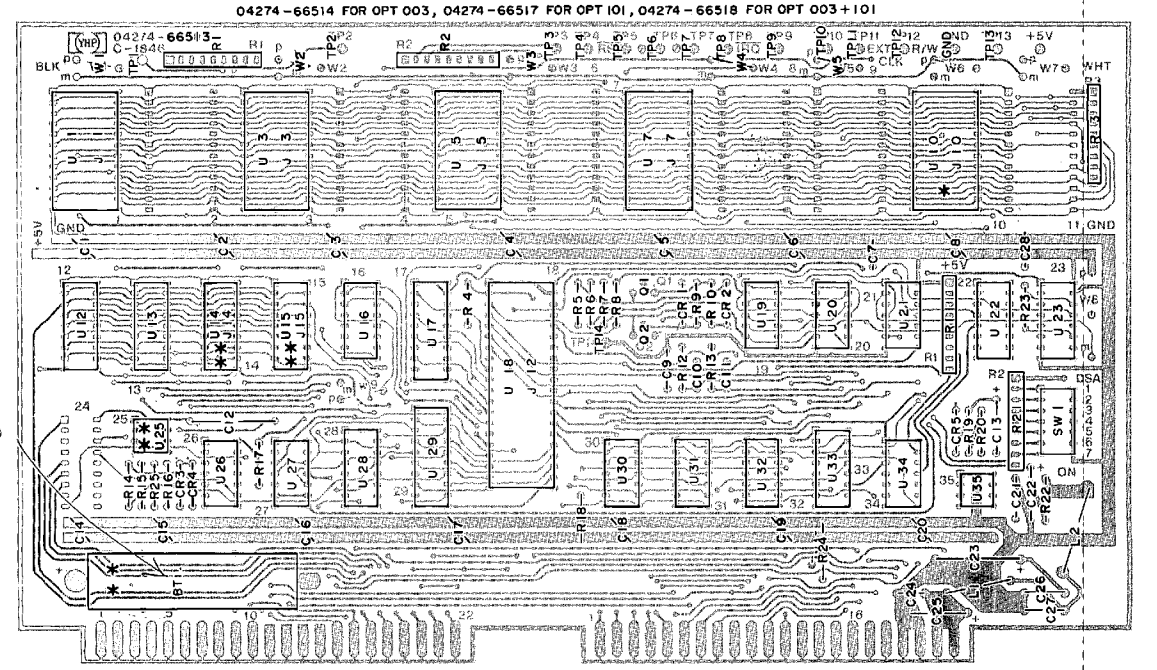
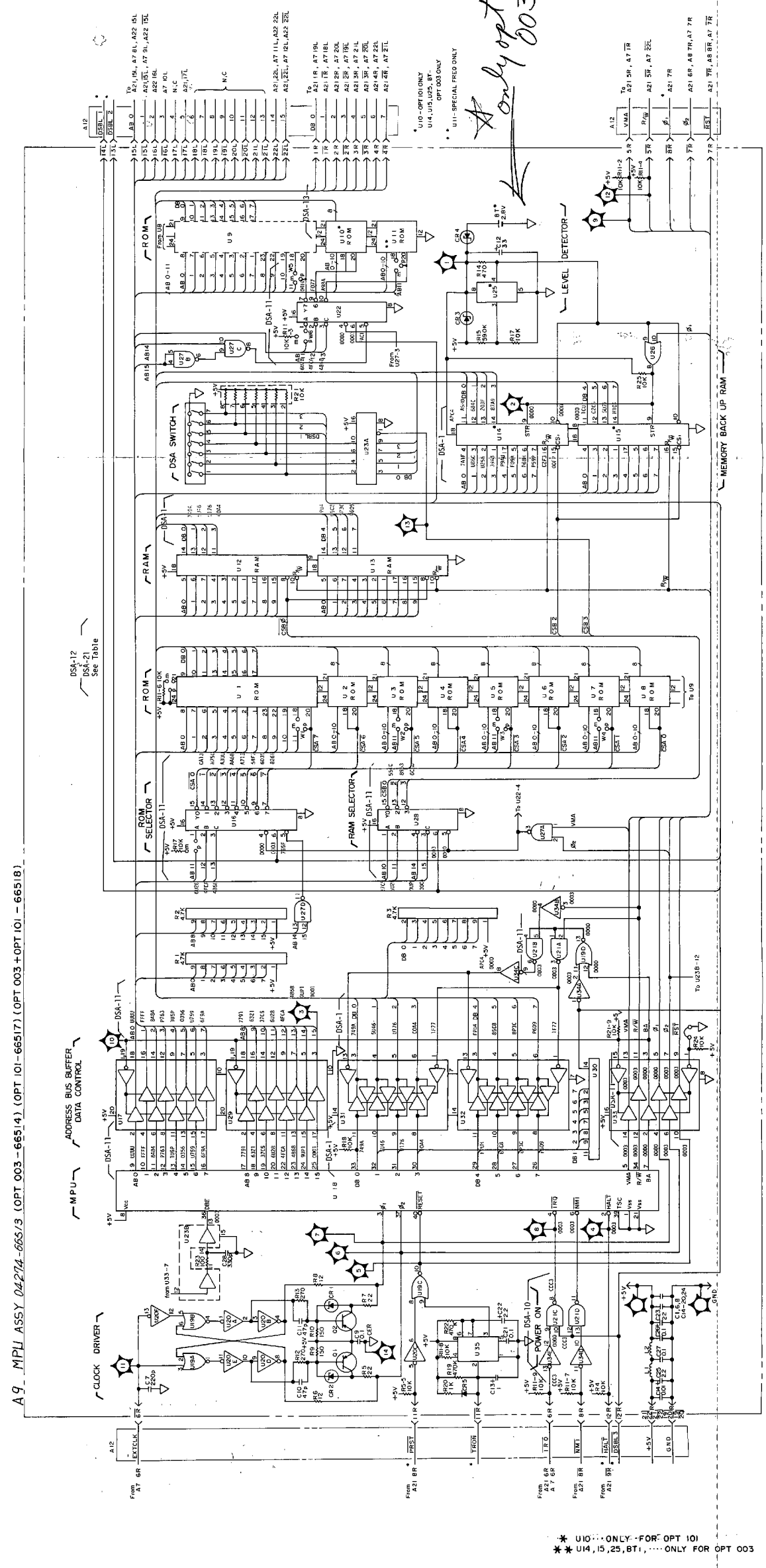





Figure 8-47. A9 MPU ASSEMBLY COMPONENT LOCATIONS.

Figure 8-48. A9 MPU ASSEMBLY SCHEMATIC DIAGRAM.

*Only opt 003*

\* U10... ONLY FOR OPT 101  
 \* U14, 15, 25, BT, ... ONLY FOR OPT 003

Signature Connections Window (+5V) : 7UUP

DSA NO	START	STOP	CLOCK	A9 DSA-SW
DSA-7	A9Tp-13	A9Tp-13	A9Tp-7	OFF
DISPLAY				

Other Settings:  
 Set ABS1-B switch to ON.  
 Disconnect one side of A8M1.

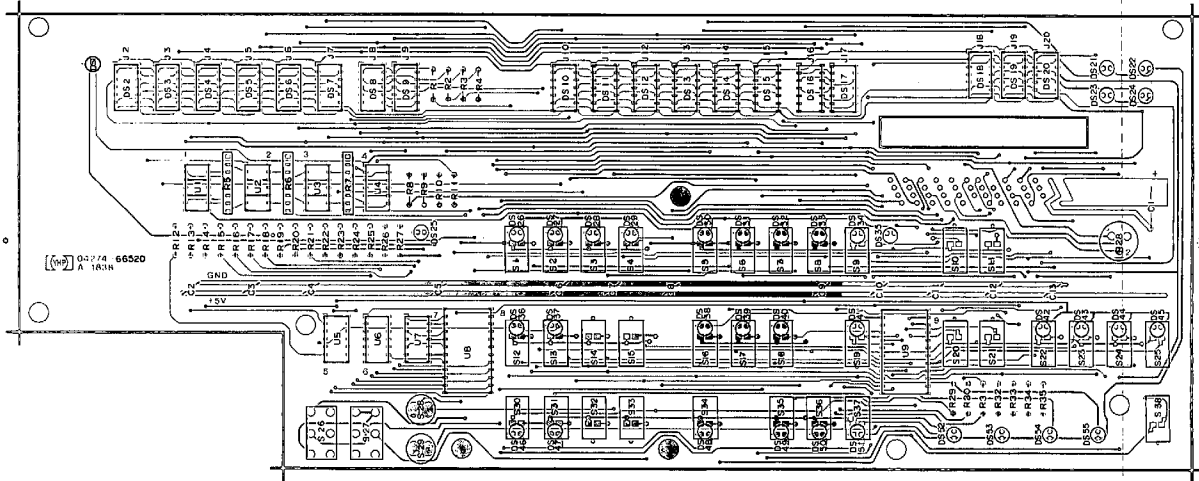

FIGURE 8-49. A10 DISPLAY AND KEY ASSEMBLY COMPONENT LOCATIONS.

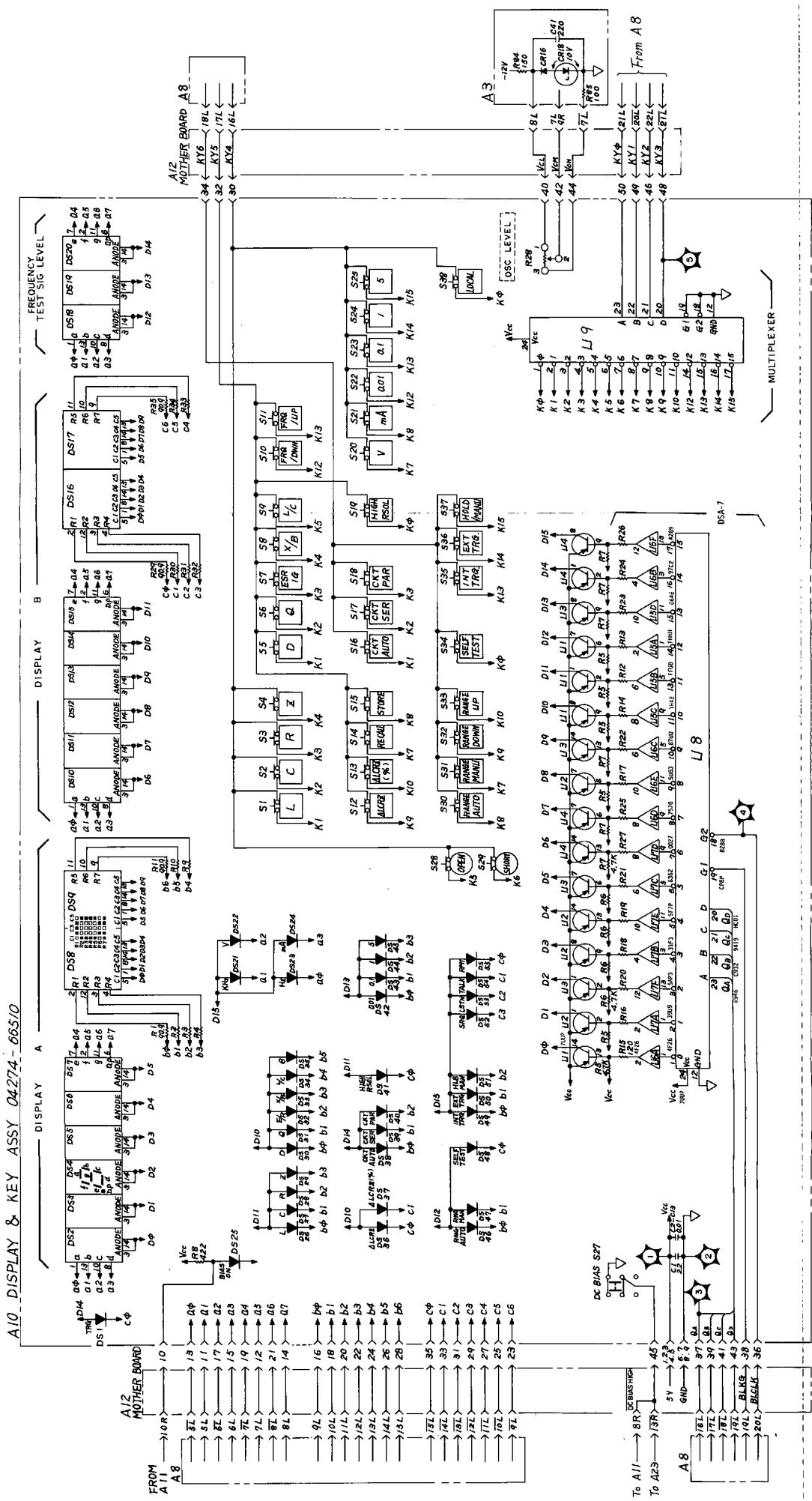

FIGURE 8-50. A10 DISPLAY AND KEY ASSEMBLY SCHEMATIC DIAGRAM.





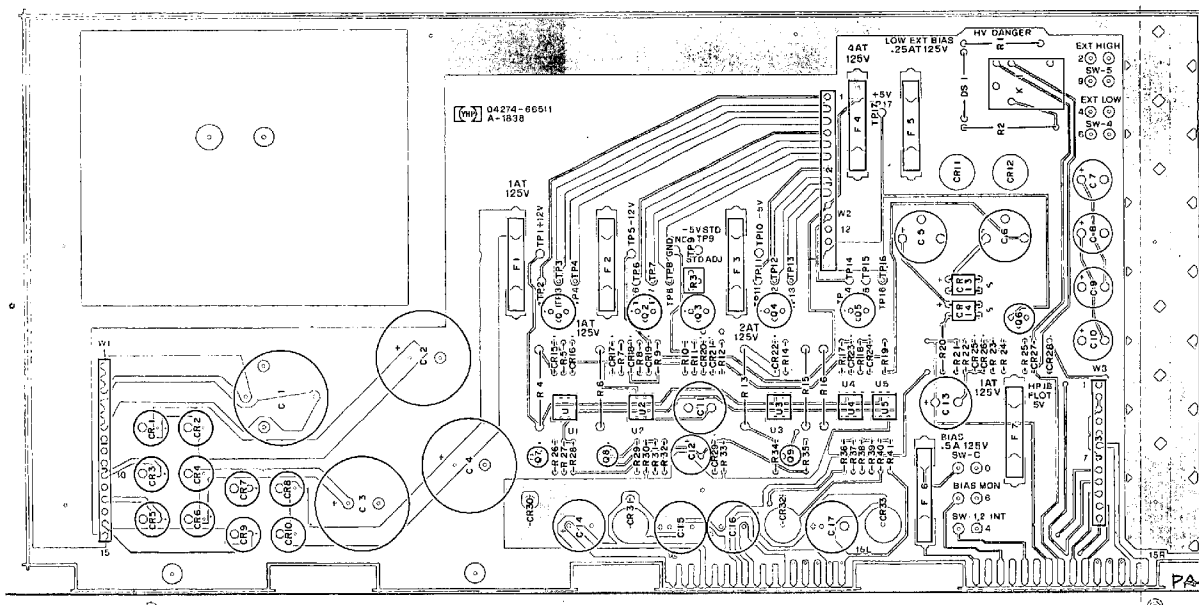

FIGURE 8-51. ALL POWER SUPPLY ASSEMBLY COMPONENT LOCATIONS.

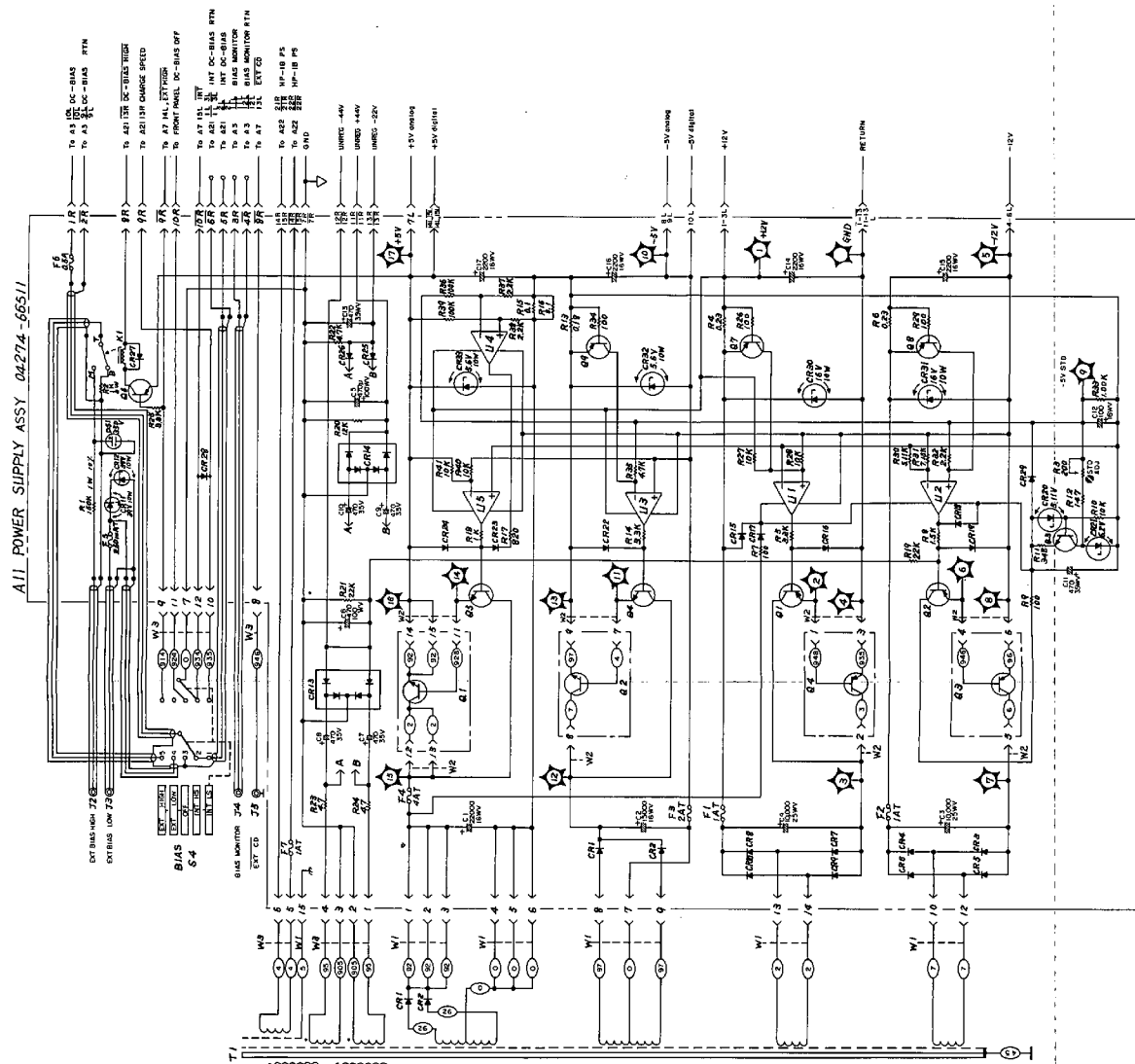

FIGURE 8-52. ALL POWER SUPPLY ASSEMBLY SCHEMATIC DIAGRAM.



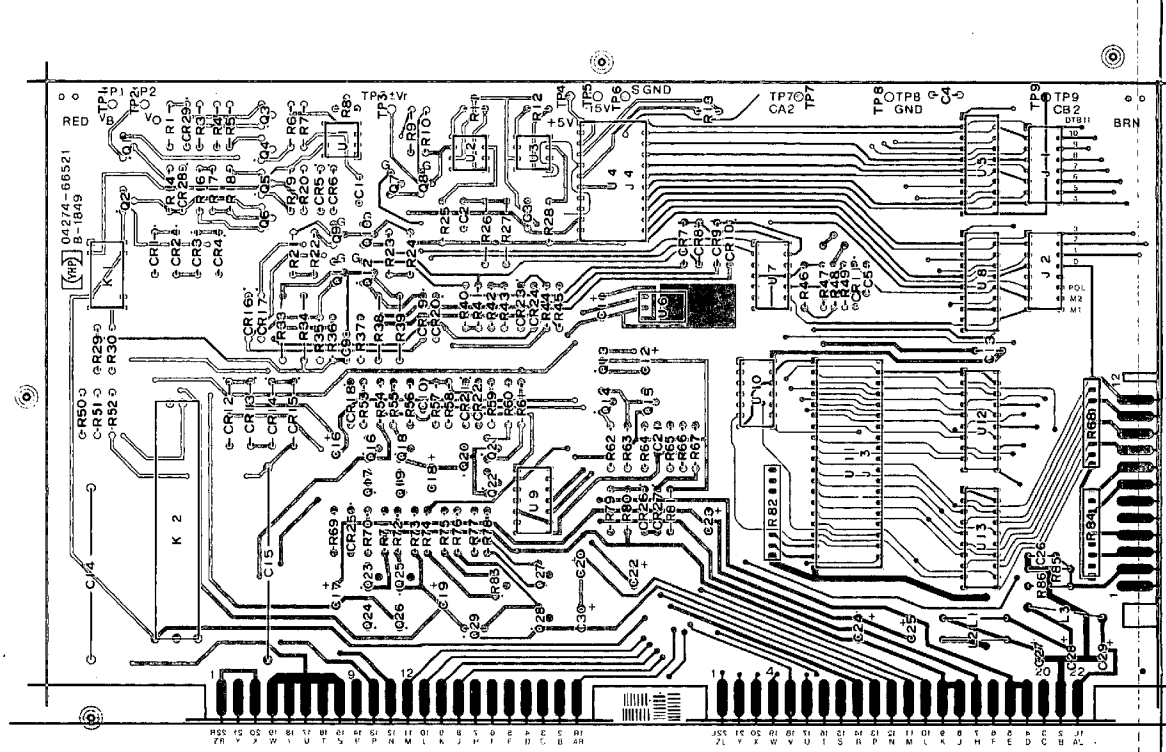

FIGURE 8-53. A21 DC BIAS ASSEMBLY COMPONENT LOCATIONS.

Signature Connections Window (+5V) : 308U

DSA NO	START	STOP	CLOCK
DSR- 8	A91p-13	A91p-13	A91p-7
DC-Bias	<input checked="" type="checkbox"/>	<input checked="" type="checkbox"/>	<input checked="" type="checkbox"/>

Other Settings:  
Connect a short jumper wire to A21SC1 (A23SC1) and A21SC2 (A23SC2).  
[In this condition, the left and right sockets are shorted.]

A21 DC BIAS ASSY 04274-66521

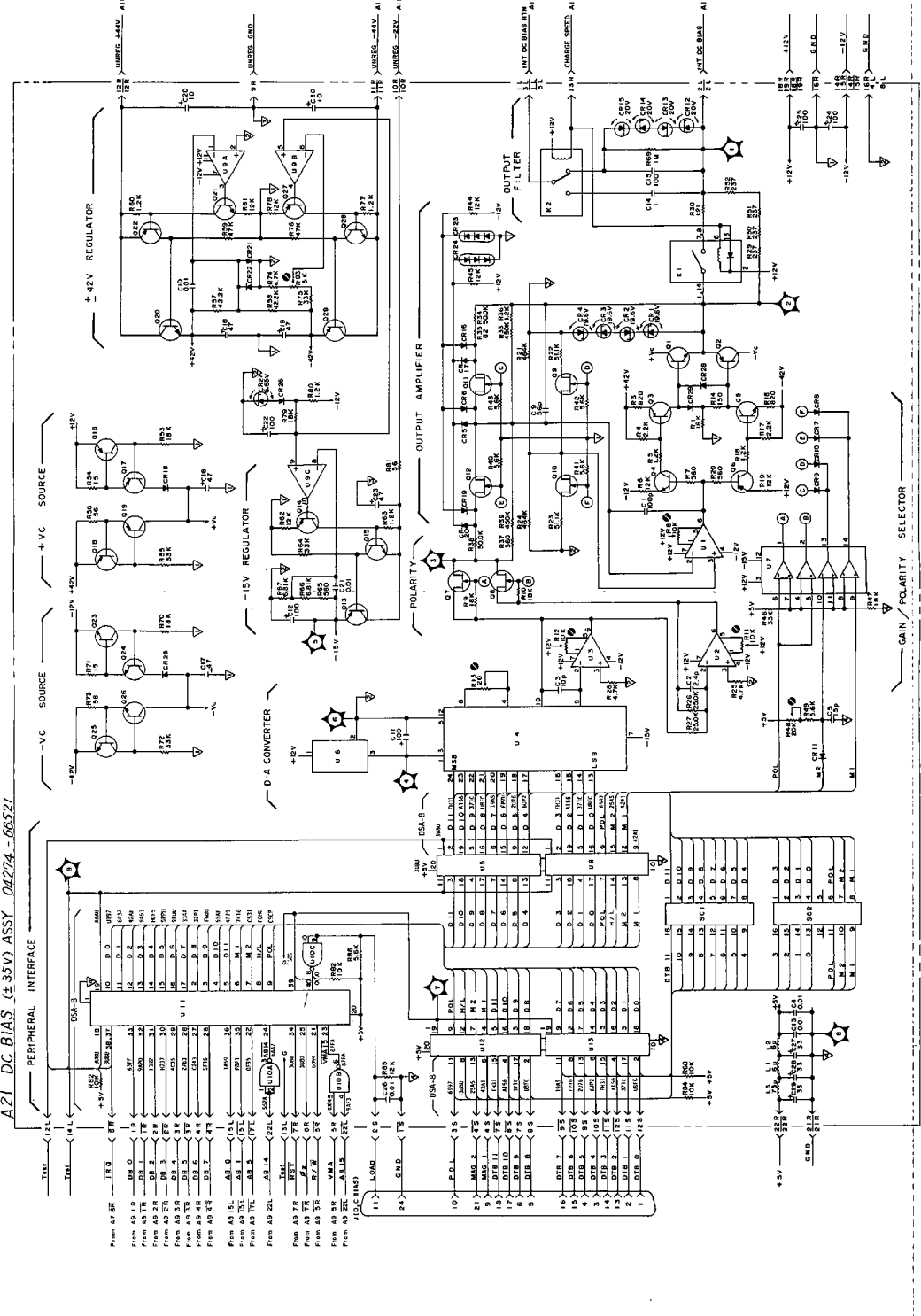

FIGURE 8-54. A21 DC BIAS ASSEMBLY SCHEMATIC DIAGRAM.



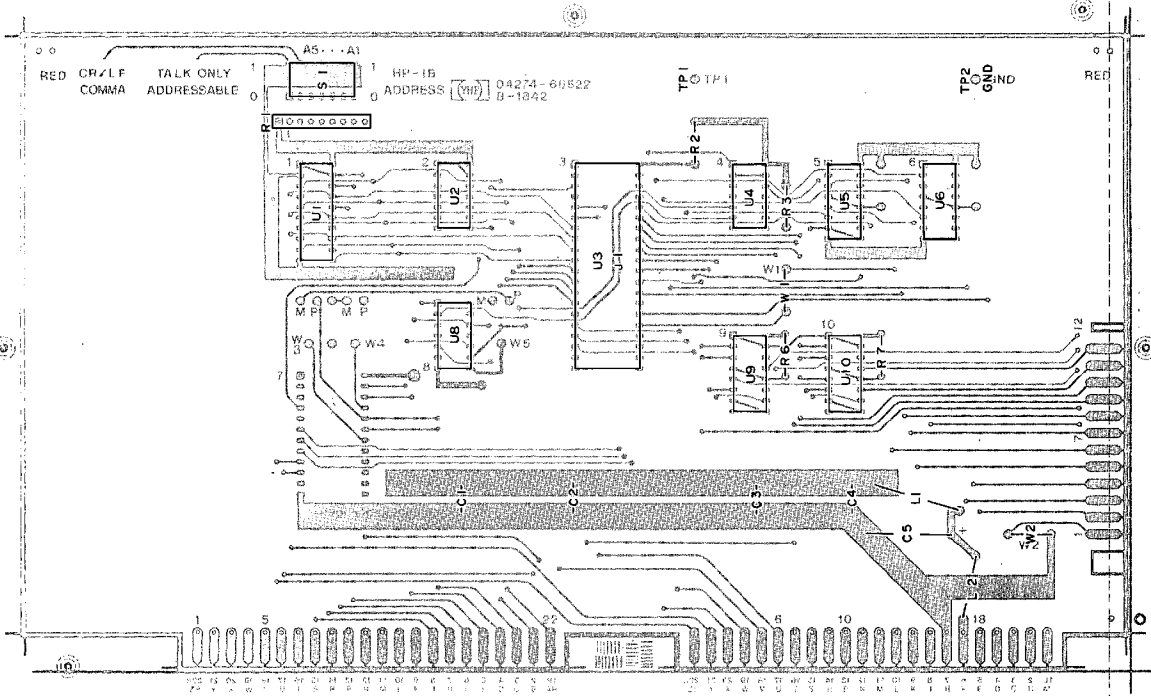

FIGURE 8-55. A22 HP-IB ASSEMBLY COMPONENT LOCATIONS.

Signature Connections Window (+5V) :3UBU

DSA NO	START	STOP	CLOCK	A9 DSA-SW
DSA-9	A9Tp-13	A9Tp-13	A9Tp-7	off
HP-IB				on

Other Settings:  
Set A22S switch (DSA-SW) as shown in schematic.

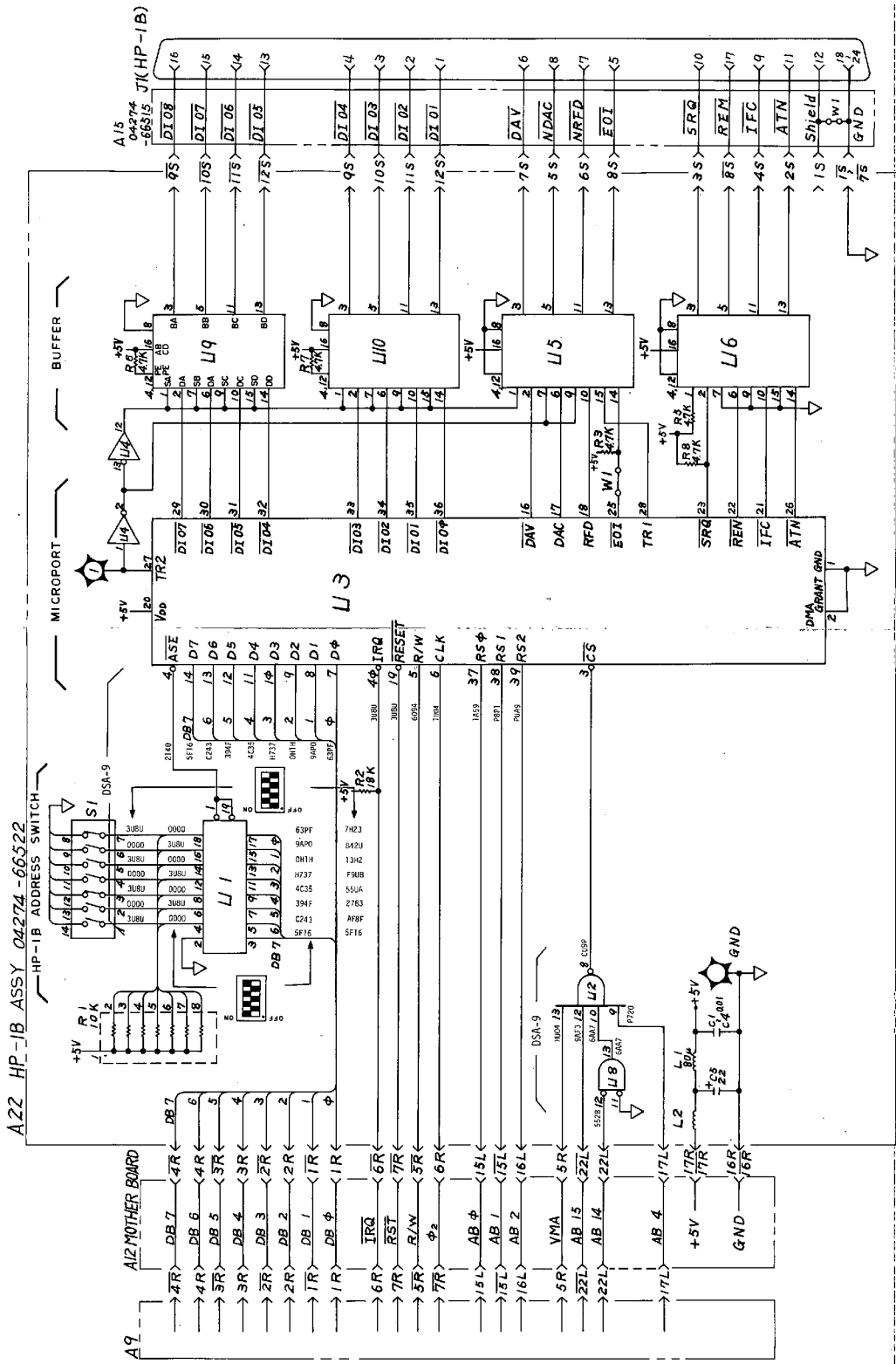

FIGURE 8-56. A22 HP-IB ASSEMBLY SCHEMATIC DIAGRAM.



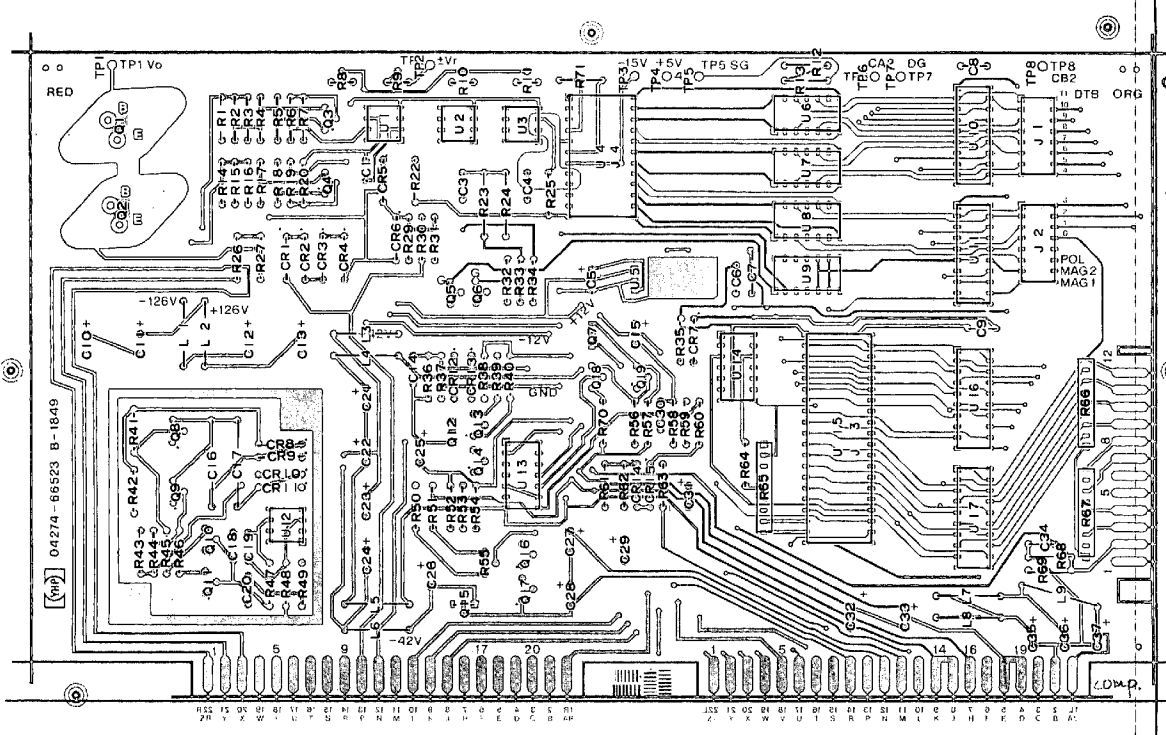

FIGURE 8-57. A23 DC Bias (±100V) Assembly Component Locations.

Signature Connections Window (+5V) : 3U8U

DSA NO	START	STOP	CLOCK	A9 DSA-SW
DSA-8	A9Tp-13	A9Tp-13	A9Tp-7	ON
DC-Bias				OFF

Other Settings:  
Refer to A21.

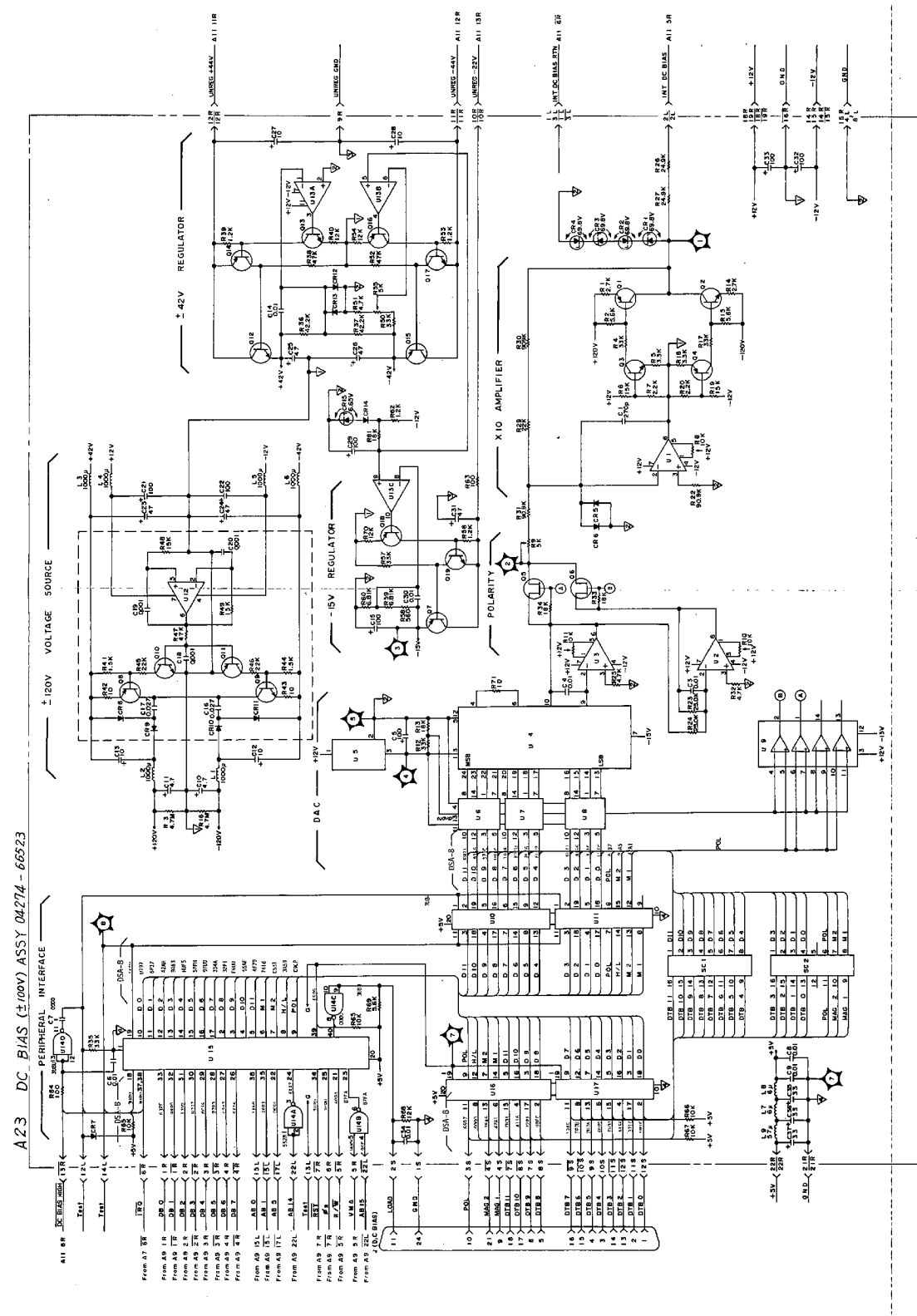

FIGURE 8-58. A23 DC Bias (±100V) Assembly Schematic Diagram.