

Errata

Title & Document Type: 8503B S-Parameter Test Set Operating and Service Manual

Manual Part Number: 08503-90004

Revision Date: March 1977

About this Manual

We've added this manual to the Agilent website in an effort to help you support your product. This manual provides the best information we could find. It may be incomplete or contain dated information, and the scan quality may not be ideal. If we find a better copy in the future, we will add it to the Agilent website.

HP References in this Manual

This manual may contain references to HP or Hewlett-Packard. Please note that Hewlett-Packard's former test and measurement, life sciences, and chemical analysis businesses are now part of Agilent Technologies. The HP XXXX referred to in this document is now the Agilent XXXX. For example, model number HP8648A is now model number Agilent 8648A. We have made no changes to this manual copy.

Support for Your Product

Agilent no longer sells or supports this product. You will find any other available product information on the Agilent Test & Measurement website:

www.agilent.com

Search for the model number of this product, and the resulting product page will guide you to any available information. Our service centers may be able to perform calibration if no repair parts are needed, but no other support from Agilent is available.



Agilent Technologies

OPERATING AND SERVICE MANUAL

8503B
75-OHM S-PARAMETER
TEST SET
500 kHz to 1.3 GHz

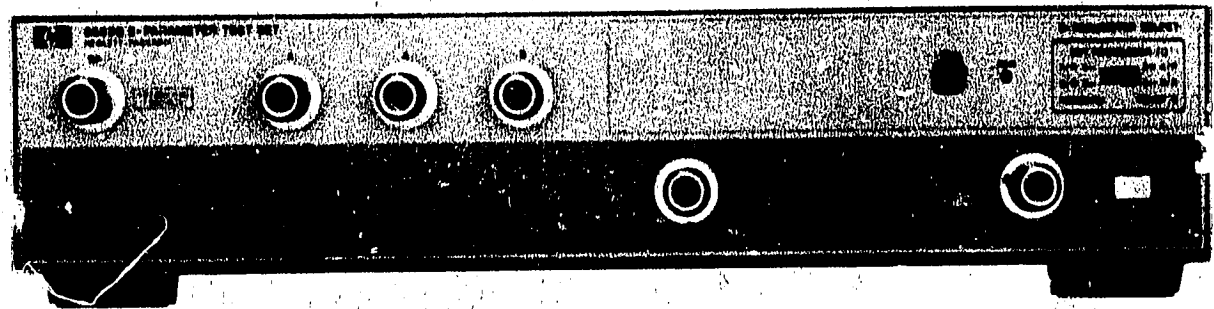

**HEWLETT
PACKARD**

CERTIFICATION

Hewlett-Packard Company certifies that this product met its published specifications at the time of shipment from the factory. Hewlett-Packard further certifies that its calibration measurements are traceable to the United States National Bureau of Standards, to the extent allowed by the Bureau's calibration facility, and to the calibration facilities of other International Standards Organization members.

WARRANTY

This Hewlett-Packard instrument product is warranted against defects in material and workmanship for a period of one year from date of shipment. During the warranty period, Hewlett-Packard Company will, at its option, either repair or replace products which prove to be defective.

For warranty service or repair, this product must be returned to a service facility designated by HP. Buyer shall prepay shipping charges to HP and HP shall pay shipping charges to return the product to Buyer. However, Buyer shall pay all shipping charges, duties, and taxes for products returned to HP from another country.

HP warrants that its software and firmware designated by HP for use with an instrument will execute its programming instructions when properly installed on that instrument. HP does not warrant that the operation of the instrument, or software, or firmware will be uninterrupted or error free.

LIMITATION OF WARRANTY

The foregoing warranty shall not apply to defects resulting from improper or inadequate maintenance by Buyer, Buyer-supplied software or interfacing, unauthorized modification or misuse, operation outside of the environmental specifications for the product, or improper site preparation or maintenance.

NO OTHER WARRANTY IS EXPRESSED OR IMPLIED. HP SPECIFICALLY DISCLAIMS THE IMPLIED WARRANTIES OF MERCHANTABILITY AND FITNESS FOR A PARTICULAR PURPOSE.

EXCLUSIVE REMEDIES

THE REMEDIES PROVIDED HEREIN ARE BUYER'S SOLE AND EXCLUSIVE REMEDIES. HP SHALL NOT BE LIABLE FOR ANY DIRECT, INDIRECT, SPECIAL, INCIDENTAL, OR CONSEQUENTIAL DAMAGES, WHETHER BASED ON CONTRACT, TORT, OR ANY OTHER LEGAL THEORY.

ASSISTANCE

Product maintenance agreements and other customer assistance agreements are available for Hewlett-Packard products.

For any assistance, contact your nearest Hewlett-Packard Sales and Service Office. Addresses are provided at the back of this manual.



**HEWLETT
PACKARD**

OPERATING AND SERVICE MANUAL

**8503B
75-OHM S-PARAMETER
TEST SET
Includes Option 001**

SERIAL NUMBERS

This manual applies directly to HP Model 8503B S-Parameter Test Set having serial prefix number 1702A.

For additional important information about serial numbers see INSTRUMENTS COVERED BY MANUAL in Section I.

©Copyright

HEWLETT-PACKARD COMPANY

1977

1400 FOUNTAIN GROVE PARKWAY, SANTA ROSA, CALIFORNIA, U.S.A.

MANUAL PART NO. 08503-90004

Operating Information Supplement Part No. 08503-90004

Printed: MARCH 1977

CONTENTS

Section	Page	Section	Page
I GENERAL INFORMATION	1-1	2-23. Bench Operation	2-6
1-1. Introduction	1-1	2-25. Rack Mounting (Option 908/909)	2-6
1-3. Operating Information Supplement	1-1	2-28. Front Handles (Option 907)	2-6
1-5. Specifications	1-1	2-30. Incoming Inspection Test	2-6
1-7. Safety Considerations	1-1	2-33. Storage and Shipment	2-6
1-8. General	1-1	2-34. Environment	2-6
1-10. Operation	1-1	2-36. Packaging	2-8
1-12. Safety Symbols	1-1	III OPERATION	3-1
1-13. Service	1-1	3-1. Introduction	3-1
1-15. Instruments Covered by Manual	1-2	3-3. Panel Features	3-1
1-20. Description	1-4	3-5. Operator's Checks	3-1
1-22. Options	1-2	3-7. Operating Instructions	3-1
1-23. Option 001 HP-IB	1-4	3-9. Fuses	3-1
1-25. Option 907 Front Handle Kit	1-4	IV PERFORMANCE TESTS	4-1
1-27. Option 908 Flange Kit	1-4	4-1. Introduction	4-1
1-29. Option 909 Rack Flange/Front Handle Kit	1-4	4-4. Equipment Required	4-1
1-31. Option 910 Additional Operating and Service Manuals	1-5	4-6. Test Record	4-1
1-33. Accessories Supplied	1-5	4-8. Directivity Test	4-1
1-35. Equipment Required But Not Supplied	1-5	4-9. Transmission Frequency Response Test	4-2
1-37. Equipment Available	1-5	4-10. Reflection Frequency Response Test	4-7
1-38. HP Model 11851A RF Cable Kit	1-5	4-11. Test Port Open/Short Ratio Test	4-12
1-40. HP Model 11855A 75-Ohm Type N Accessory Kit	1-5	4-12. Test Port Return Loss Test	4-21
1-42. HP Model 11856A 75-Ohm BNC Accessory Kit	1-5	4-13. Port Return Loss Tests	4-22
1-44. HP Model 11857B/C Test Port Extension Cable Sets	1-5	V ADJUSTMENTS	5-
1-46. HP Model 85030A Accuracy Improved Measurement (AIM) Program	1-6	5-1. Introduction	5-1
1-48. HP Model 85036A 75-Ohm Type N Calibration Kit	1-6	VI REPLACEABLE PARTS	6-1
1-50. Recommended Test Equipment	1-6	6-1. Introduction	6-1
II INSTALLATION	2-1	6-3. Abbreviations	6-1
2-1. Introduction	2-1	6-5. Replaceable Parts List	6-1
2-3. Initial Inspection	2-1	6-7. Ordering Information	6-1
2-5. Preparation for Use	2-1	VII MANUAL CHANGES	7-1
2-6. Power Requirements	2-1	7-1. Introduction	7-1
2-8. Line Voltage and Fuse Selection	2-1	VIII SERVICE	8-1
2-10. Cable Connections	2-3	8-1. Introduction	8-1
2-15. Mating Connectors	2-3	8-3. Assembly Service Sheets	8-1
2-17. Operating Environment	2-5	8-5. Theory of Operation	8-1
2-19. Installation Instructions	2-5	8-7. Troubleshooting	8-1
		8-11. Recommended Test Equipment	8-1
		8-13. Repair	8-1
		8-14. Directional Bridges	8-1
		8-16. After Service Product Safety Checks	8-1

ILLUSTRATIONS

Figure	Page	Figure	Page
1-1. Model 8503B 75-Ohm S-Parameter Test Set with Accessories Supplied	1-0	4-11. Port Return Loss Test Setup	4-22
1-2. Typical Serial Number Plate	1-2	4-12. Port Return Loss (1000 – 1300 MHz).	4-25
2-1. Line Voltage Selection with Power Module PC Board	2-2	4-13. Port Return Loss (100 – 1000 MHz).	4-26
2-2. AC Power Cables Available	2-4	4-14. Port Return Loss (2 – 100 MHz)	4-27
2-3. Changing 8505A Operating Instruction Sheet to Bottom of 8503B	2-7	4-15. Port Return Loss (0.5 – 2 MHz).	4-28
2-4. Lock Feet, Right Side of Rear Panel	2-7	6-1. Type N 50-Ohm Connector Assembly, Exploded View	6-7
2-5. Attaching Rack Mounting Hardware and Handles	2-9	6-2. Type N 75-Ohm Female Connector Assembly, Exploded View	6-8
2-6. Incoming Inspection Test	2-10	6-3. Cabinet Parts, Exploded View	6-9
3-1. Front and Rear Panel Controls, Connectors and Indicators.	3-2	6-4. Mechanical Parts Location.	6-11
3-2. Operator's Checks	3-5	8-1. Schematic Diagram Notes	8-2
3-3. RF Signal Path	3-10	8-2. Simplified Block Diagram of 8503B, Including Option 001 (HP-IB).	8-5
3-4. Amplifier Measurement Local Operation	3-11	8-3. RF Troubleshooting Block Diagram	8-7
3-5. HP-IB Option 001 Remote Operation	3-14	8-4. Switch Control and Front Panel Indicator Troubleshooting Block Diagram	8-7
4-1. Transmission Frequency Response Test Setup	4-2	8-5. A6 Decoder/Driver Assembly, Component Locations.	8-9
4-2. Transmission Frequency Response Magnitude	4-5	8-6. A1 Front Panel Switch Board Assembly and A6 Decoder/Driver Assembly, Schematic	8-9
4-3. Transmission Frequency Response Phase	4-6	8-7. A2 Splitter/Directional Bridge and A3 Directional Bridge, Connector Locations	8-11
4-4. Reflection Frequency Response Test Setup	4-7	8-8. A2 Splitter/Directional Bridge Assembly, A3 Directional Bridge Assembly, and A5 Coaxial Switch Assembly, Schematic	8-11
4-5. Reflection Frequency Response Magnitude	4-10	8-9. A8 HP-IB Assembly, Component Locations.	8-13
4-6. Reflection Frequency Response Phase	4-11	8-10. A8 HP-IB Assembly, Schematic	8-13
4-7. Test Port Open/Short Ratio Test	4-13	8-11. A4 Power Supply Assembly, Component Locations.	8-15/8-16
4-8. Test Port Open/Short Ratio Magnitude, >2 MHz.	4-16	8-12. A4 Power Supply Assembly, Schematic	8-15/8-16
4-9. Slope Peak-to-Peak Measurement	4-17	8-13. 8503B Major Assemblies, Cables, and Connector Locations.	8-17/8-18
4-10. Test Port Open/Short Ratio Phase, >2 MHz.	4-19		

TABLES

Table	Page	Table	Page
1-1. Model 8503B Specifications	1-3	4-1. Reflection Coefficient (ρ) of Coaxial Cable Used for 6-Ft. "Test" Cable.	4-18
1-2. Model 8503B Supplemental Characteristics	1-4	4-2. Model 8503B Performance Test Record	4-30
1-3. 11855A 75-Ohm Type N Accessory Kit.	1-5	6-2. Reference Designations and Abbreviations	6-2
1-4. 11856A 75-Ohm BNC Accessory Kit.	1-5	6-3. Code List of Manufacturers	6-12
1-5. 85036A 75-Ohm Type N Calibration Kit	1-6	8-1. Data Direction Control Operation.	8-12
1-6. Recommended Test Equipment	1-7	8-2. 8503B HP-IB Output Data	8-12
2-1. Model 8503B Mating Connectors	2-3	8-3. Summary of Codes Generated by Data Sequencer and Encoder	8-12
2-2. Rack-Mounting Kits for 8503B	2-6		

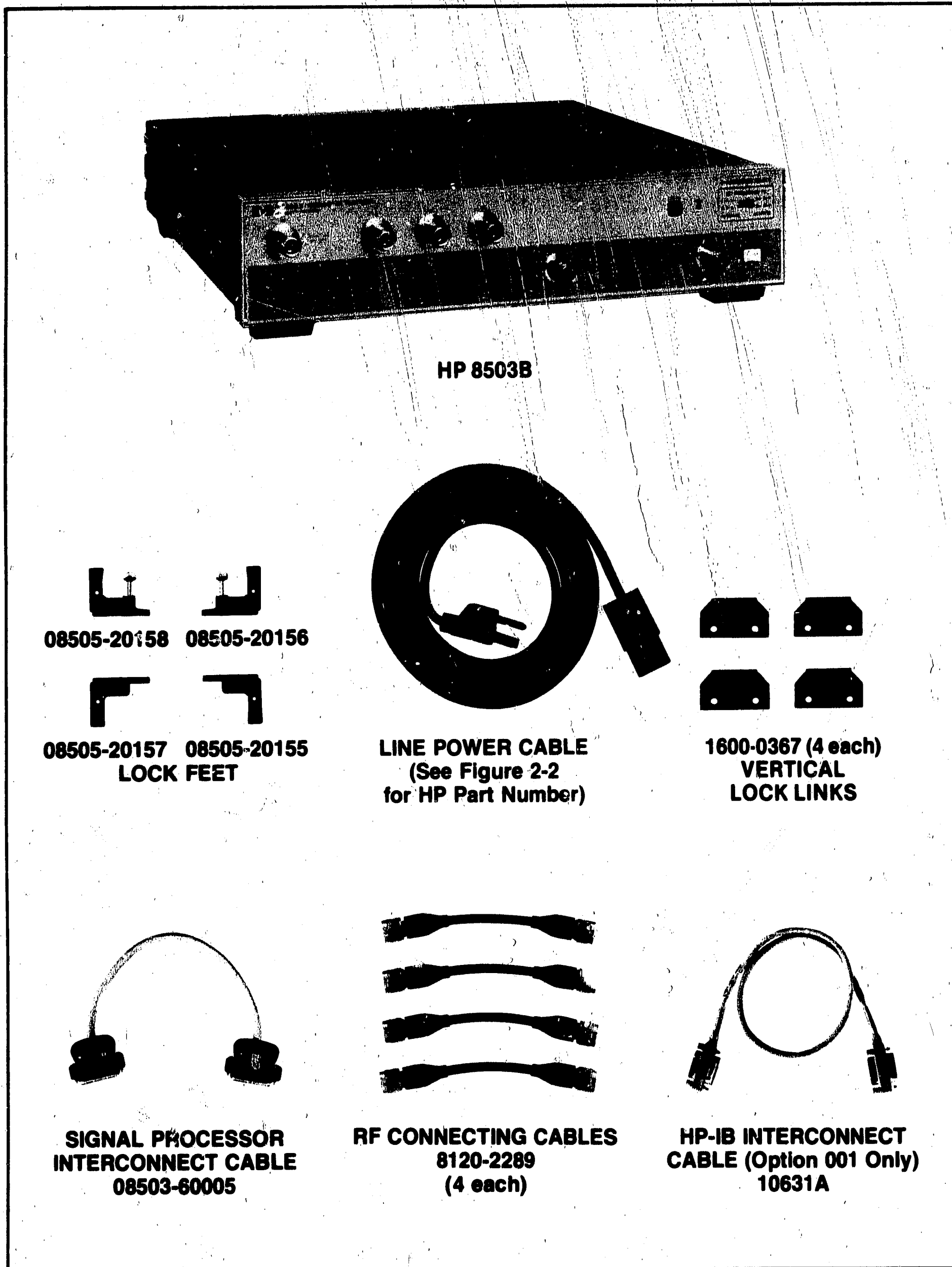

Figure 1-1. Model 8503B 75-Ohm S-Parameter Test Set with Accessories Supplied

SECTION I GENERAL INFORMATION

1-1. INTRODUCTION

1-2. This Operating and Service Manual contains information required to install, operate, test, adjust, and service the Hewlett-Packard Model 8503B. Figure 1-1 shows the instrument and accessories supplied. This section covers instrument identification, description, options, accessories, specifications, and other basic information.

1-3. OPERATING INFORMATION SUPPLEMENT

1-4. Supplied with this manual is an Operating Information Supplement. The Supplement is a copy of the first three sections of the manual, and should be kept with the instrument for use by the operator. Additional copies of the operation Information Supplement can be ordered separately through your nearest Hewlett-Packard office. The part number is listed on the title page.

1-5. SPECIFICATIONS

1-6. Instrument specifications are listed in Table 1-1. These specifications are the performance standards or limits against which the instrument is tested. Table 1-2 lists supplemental characteristics. Supplemental characteristics are not specifications but are included as additional information for the user.

1-7. SAFETY CONSIDERATIONS

1-8. General

1-9. This is a Safety Class I instrument and has been manufactured and tested according to international safety standards.

1-10. Operation

1-11. **BEFORE APPLYING POWER** make sure the instrument's ac input is set for the available ac

line voltage, that the correct fuse is installed, and that all normal safety precautions have been taken. (See Warnings below).

1-12. Safety Symbols



Instruction manual symbol: The apparatus will be marked with this symbol when it is necessary for the user to refer to the instruction manual in order to protect the apparatus against damage.



Indicates dangerous voltages



Earth Terminal

WARNING

The **WARNING** sign denotes a hazard. It calls attention to a procedure, practice, or the like, which, if not correctly performed or adhered to, could result in injury or loss of life. Do not proceed beyond a **WARNING** sign until the indicated conditions are fully understood and met.

CAUTION

The **CAUTION** sign denotes a hazard. It calls attention to an operating procedure, practice, or the like, which, if not correctly performed or adhered to, could result in damage to or destruction of part or all of the equipment. Do not proceed beyond a **CAUTION** sign until the indicated conditions are fully understood and met.

1-13. Service

1-14. Although this instrument has been manufactured in accordance with safety standards, this manual contains information, cautions, and warnings which must be followed to ensure safe operation. Service should be performed only by qualified service personnel, and the following warnings should be observed:

WARNINGS

Any maintenance or repair of the opened instrument under voltage should be avoided as much as possible, and when inevitable, should be carried out only by a skilled person who is aware of the hazard involved.

Capacitors inside the instrument may still be charged even if the instrument has been disconnected from its source of supply.

Make sure that only fuses with the required rated current and of the specified type (normal blow, time delay, etc.) are used for replacement. Do not use repaired fuses or short-circuit fuseholders.

When it is likely that the grounding protection has been impaired, the instrument must be made inoperative and be secured against any unintended operation.

If this instrument is to be energized via an auto-transformer (for voltage reduction) make sure the common terminal is connected to the earthed pole of the power source.

BEFORE SWITCHING ON THE INSTRUMENT, the protective earth terminals of the instrument must be connected to the protective conductor of the mains power cord. The mains plug shall only be inserted in a socket outlet provided with a protective earth contact. The protective action must not be negated by the use of an extension cord (power cord) without a protective conductor (grounding). Grounding one conductor of a two conductor outlet is not sufficient protection.

Any interruption of the protective (grounding) conductor (inside or outside the instrument) or disconnecting the protective earth terminal is likely to make this instrument dangerous.

CAUTIONS

BEFORE SWITCHING ON THIS INSTRUMENT, make sure instrument's ac input is set to the voltage of the ac power source (see Figure 2-1).

BEFORE SWITCHING ON THIS INSTRUMENT, make sure the ac line fuse is of the required current rating and type (normal-blow, time delay, etc.).

1-15. INSTRUMENTS COVERED BY MANUAL

1-16. Attached to the instrument is a serial number plate (Figure 1-2). The serial number is in two parts. The first four digits and the letter are the serial number prefix; the last five digits are the suffix. The prefix is the same for all identical instruments; it changes only when a change is made to the instrument. The suffix, however, is assigned sequentially and is different for each instrument. The contents of this manual apply to instruments with the serial number prefix(es) listed under SERIAL NUMBERS on the title page.

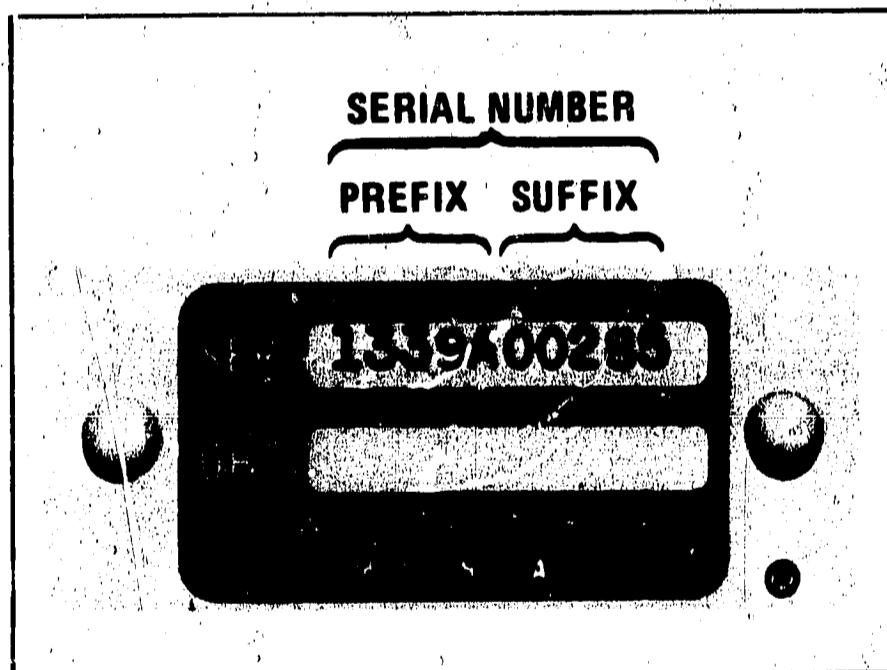

Figure 1-2. Typical Serial Number Plate

1-17. An instrument manufactured after the printing of this manual may have a serial number prefix that is not listed on the title page. This unlisted serial number prefix indicates the instrument is different from those described in this manual. The manual for this newer instrument is accompanied by a yellow Manual Changes supplement. This supplement contains "change information" that explains how to adapt the manual to the newer instrument.

Table 1-1. Model 8503B Specifications

SPECIFICATIONS

Frequency Range: 500 kHz to 1.3 GHz

Directivity: ≥ 40 dB

Frequency Response:

Transmission¹ (S_{21} , S_{12}): ± 1 dB, $\pm 12^\circ$ from 0.5 to 1300 MHz.

Reflection¹ (S_{11} , S_{22}): ± 2 dB, $\pm 20^\circ$ from 0.5 to 1300 MHz; $\pm 15^\circ$ from 2 to 1300 MHz.

Port Match²:

Test Port 1 and 2:

Frequency Range (MHz)	Return Loss
0.5 to 2	≥ 18.0 dB (≤ 1.29 SWR)
2 to 1300	≥ 24 dB (≤ 1.135 SWR)

Test Port 1 and 2 Open/Short Ratio:

Frequency Range (MHz)	Magnitude	Phase
0.5 to 2	$\leq \pm 1.25$ dB	$\leq \pm 10^\circ$
2 to 1300	$\leq \pm 0.9$ dB	$\leq \pm 7.5^\circ$

Reference and Return Ports (R, A, B):

Frequency Range (MHz)	Return Loss
0.5 to 2	≥ 20 dB (≤ 1.22 SWR)
2 to 1000	≥ 23 dB (≤ 1.15 SWR)
1000 to 1300	≥ 20 dB (≤ 1.22 SWR)

RF Input Port: ≥ 20 dB Return Loss from 0.5 to 1300 MHz (≤ 1.22 SWR).

Maximum Operating Level: +20 dBm (100 mW)

¹ \pm Degrees specified as deviation from Linear Phase.

² Effective Port match for ratio measurement.

Table 1-2. Model 8503B Supplemental Characteristics

SUPPLEMENTAL CHARACTERISTICS	
NOTE: Values in this table are not specifications; they are typical characteristics included for user information.	
Insertion Loss: Input to Port 1 & 2: 19 dB Nominal Input to Port A or B: 25 dB Nominal Input to Port R: 19 dB Nominal Tracking Between Reference and Test Port 1 and 2: Transmission (S_{21}, S_{12}): $\leq \pm 0.5$ dB Magnitude and $\leq \pm 4^\circ$ Phase (deviation from Linear Phase). Reflection (S_{11}, S_{22}): $\leq \pm 0.75$ dB Magnitude and $\leq \pm 6^\circ$ Phase (deviation from Linear Phase). RF Input to Test Port 1 or 2: $\leq \pm 1.5$ dB. Impedance: Test Ports 1 and 2 75 Ω ; all other RF Ports 50 Ω . Connectors: Test Ports 1 and 2: 75 Ω Type N Female.	All Other RF Ports: 50 Ω Type N Female DC Bias Inputs: 50 Ω BNC Female DC Bias Input Range: ± 30 Vdc, ± 200 mA; some degradation in RF Specifications from 500 kHz to 100 MHz; 500 mA maximum. Δ Damage Level: 1 watt (+30 dBm) CW Power: Selection of 100, 120, 220, or 240 V, +5% -10%, 50-60 Hz. Approximately 15VA. Dimensions: 432 mm wide, 90 mm high, 495 mm deep (17 in. x 3 1/2 in. x 19 1/2 in.) Weight: Net, 9, 1 kg (20 lb). Shipping, 11,3 kg (25 lb)

1-18. In addition to change information, the supplement may contain information for correcting errors in the manual. To keep this manual as current as possible, Hewlett-Packard recommends that you periodically request the latest Manual Changes supplement. The supplement for this manual is identified with this manual's print date and part number, both of which appear on the manual's title page. Complimentary copies of the supplement are available from Hewlett-Packard.

1-19. For information concerning a serial number prefix that is not listed on the title page or in the Manual Changes supplement, contact your nearest Hewlett-Packard office.

1-20. DESCRIPTION

1-21. The HP Model 8503B S-Parameter Test Set is designed to interface with the HP Model 8505A Network Analyzer. The 8503B together with the 8505A provides a convenient means of measuring reflection and transmission coefficients (scattering parameters) of a one-port or two-port device operating within the frequency range of 500 kHz to 1.3 GHz.

1-22. OPTIONS

1-23. Option 001 HP-IB

1-24. Option 001 provides the 8503B S-Parameter Test Set with Hewlett-Packard Interface Bus (HP-IB). The HP-IB option permits communication between instruments when used with HP Model 8507A/B calculator-based Automatic Network Analyzer.

1-25. Option 907 Front Handle Kit

1-26. Option 907, HP Part Number 5061-0088, contains front handles and necessary hardware for attaching the handles. See Figure 2-3 for installation procedure.

1-27. Option 908 Rack Flange Kit

1-28. Option 908, HP Part Number 5061-0076, contains flanges and hardware required to mount the 8503B in an equipment rack with 482.6 mm (19 inches) horizontal spacing. See Figure 2-3 for installation procedure.

1-29. Option 909 Rack Flange/Front Handle Kit

1-30. Option 909, HP Part Number 5061-0082, consists of one Option 907 Front Handle Kit and one Option 908 Rack Flange Kit (see descriptions above.) See Figure 2-3 for installation procedure.

1-31. Option 910 Additional Operating and Service Manuals

1-32. Option 910 provides additional Operating and Service manual(s). The number of additional manuals depends on quantity of Option 910's ordered. To obtain additional Operating and Service manuals after initial shipment, order by manual part number (see title page).

1-33. ACCESSORIES SUPPLIED

1-34. Figure 1-1 shows the HP Model 8503B S-Parameter Test Set, line power cable, Signal Processor interconnect cable, HP-IB interconnect cable, and four 19 cm (7-1/2 inch) RF connecting cables.

1-35. EQUIPMENT REQUIRED BUT NOT SUPPLIED

1-36. To have a complete measurement system, the Model 8503B must be used with a Network Analyzer such as the HP Model 8505A.

1-37. EQUIPMENT AVAILABLE**1-38. HP Model 11851A RF Cable Kit**

1-39. The 11851A cable kit includes four 61 cm (24 inch) cables which are phase matched to a standard within $\pm 2^\circ$ at 1300 MHz. These cables may be used to provide RF connections between the 8505A and 8503B when the S-Parameter Test Set is set on top of the Network Analyzer or off to one side.

1-40. HP Model 11855A 75-Ohm Type N Accessory Kit

1-41. The 11855A Accessory Kit furnishes the RF components generally required when measuring devices having 75-ohm type N connectors (see Table 1-3). The HP Model 85036A Calibration Kit is also required for use with the 11855A Accessory Kit.

1-42. HP Model 11856A 75-Ohm BNC Accessory Kit

1-43. The 11856A Accessory Kit furnishes the RF components generally required when measuring devices having 75-ohm BNC connectors (see Table 1-4). The HP Model 85036A Calibration Kit is also required for use with the 11856A Accessory Kit.

Table 1-3. 11855A 75-Ohm Type N Accessory Kit

Qty	Description	HP Part Number
1	75 Ω Type N Female short	1250-1531
1	75 Ω Type N Male short	1250-1530
2	75 Ω Type N Male to Male adapter	1250-1528
2	75 Ω Type N Female to Female adapter	1250-1529
1	Type N Male 75 Ω termination	1250-1532
1	Storage Case	

Table 1-4. 11856A 75-Ohm BNC Accessory Kit

Qty	Description	HP Part Number
2	75 Ω Type N Male BNC Female adapter	1250-1535
2	75 Ω Type N Male to BNC Male adapter	1250-1533
2	75 Ω Type N Female to Male adapter	1250-1534
2	75 Ω Type N Female to Female adapter	1250-1536
1	BNC Male short	1250-0929
1	BNC Male 75 Ω termination	11652-60010
1	Storage Case	

1-44. HP Model 11857B/C Test Port Extension Cable Sets

1-45. The 11857B and 11857C Test Port Extension Cable Sets each contain two precision 61cm (24-inch) cables. These cables are designed to adapt the 8503B test port spacing to almost any two-port coaxial device.

1-46. HP Model 85030A Accuracy Improved Measurement (AIM) Program

1-47. The AIM Program substantially improves measurement accuracy by removing mismatch, directivity, and frequency tracking errors for both one and two port components. The 85030A AIM Program includes cassette and operating manual for use with the 8507A Automatic Network Analyzer.

1-48. HP Model 85036A 75-Ohm Type N Calibration Kit

1-49. The 85036A Calibration Kit is recommended for measurement of devices having 75-ohm Type N RF connectors. (See Table 1-5).

1-50. RECOMMENDED TEST EQUIPMENT

1-51. Equipment required for incoming inspection, performance testing and troubleshooting of the Hewlett-Packard Model 8503B S-Parameter Test Set is listed in Table 1-6. Other equipment

may be substituted if it meets or exceeds the critical specifications listed in the table.

Table 1-5. 85036A 75-Ohm Type N Calibration Kit

Qty	Description	HP Part Number
1	75Ω Type N Male to Type N Male adapter	1250-1528
1	75Ω Type N Female to Type N Female adapter	1250-1529
1	75Ω Type N Male short	1250-1530
1	75Ω Type N Female short	1250-1531
1	Type N Male 75Ω termination	1250-1540
1	Type N Female 75Ω termination	1250-1541
1	Storage Case	

Table 1-6. Recommended Test Equipment (1 of 2)

Instrument	Critical Specifications	Recommended Model	Use*
Network Analyzer	Frequency Range: 0.5 – 1300 MHz	HP 8505A	P,T,I
Multimeter	Range: AC: 0 to 300 V; DC: 0 to 50V Ohms: X100	HP 3490A	T
Dual Directional Coupler	Frequency Range: 100 – 1300 MHz Directivity: ≥ 36 dB, 0.1 – 1GHz ≥ 32 dB, 1.0 – 1.3 GHz	HP 778D, Opt. 012	P
Directional Bridge	Frequency Range: 0.5 – 100 MHz Directivity: ≥ 40 dB, 1 – 100 MHz ≥ 30 dB, .5 – 1 MHz	HP 8721A ¹	P
3-Way Power Splitter	Tracking between any two ports: ≤ 0.1 dB Magnitude $\leq 1.5^\circ$ Phase ≥ 32 dB Output Source Match	HP 11850A	P
Termination, 75Ω	Impedance: 75Ω with Type N male connector, SWR ≤ 1.006	HP 1250-540 ²	P
Termination, 75Ω	Impedance: 75Ω with Type N female connector	HP 1250-1541 ²	P
Termination, 50Ω (4 required)	Impedance: 50Ω with Type N male connector	HP 909A, Opt. 012	P
50Ω to 75Ω Minimum Loss Pad	Return Loss: > 34 dB (75Ω port)	HP 11852A	P
Short, 75Ω	Type N female connector, 75Ω	HP 1250-1531 ³	P
Short, 50Ω	Type N female connector, 50Ω	HP 11511A	P,T
Short, 75Ω	Type N male connector, 75Ω	HP 1250-1530 ³	P,T
Adapter, 75Ω	Type N male to Type N male, 75Ω	HP 1250-1528 ²	P
Adapter, 50Ω (2 required)	Type BNC male to Type N male, 50Ω	HP 1250-1473 ⁴	P
Adapter, 50Ω	Type BNC male to Type N female, 50Ω	HP 1250-1477 ⁴	P
Adapter, 50Ω	Type N female to SMA female, 50Ω	Cablewave Systems No. 721	T
Adapter, 50Ω (2 required)	Type N female to SMA male, 50Ω	Cablewave Systems No. 718	T

Table 1-6. Recommended Test Equipment (1 of 2)

Instrument	Critical Specifications	Recommended Model	Use*
Adapter, 50Ω	Type N female to Type N female, 50Ω	HP 1250-0777	P
Cable (2 required)	6 ft. 50Ω coaxial cable, Type RG-214, with Type N male connectors on both ends	HP 11500A	P
Cable	2 ft. 75Ω coaxial cable, Type TRF-59 with Type N male connector on one end and Type N female connector on other end	HP 8120-2409 ⁵	P
Cable Set	Four 24 in. 50Ω coaxial cables phase matched to a standard with ±2° at 1300 MHz with Type N male connectors on both ends	HP 11851A	P
Cable Set	2 ft. 75Ω coaxial cables (2), each Type TRF-59 with Type N male connector on one end and GR-900 connector on other end	HP 11857C	P

*P = Performance; T = Troubleshooting; I = Incoming Inspection
¹ This part is included in HP 11652A Transmission/Reflection Kit
² Included in HP 85036A 75Ω Type N Calibration Kit
³ Included in HP 11855A 75Ω Type N Accessory Kit
⁴ Included in HP 11854A 50Ω BNC Accessory Kit
⁵ Included in HP 11857B Test Port Extension Cable Set

SECTION II INSTALLATION

2-1. INTRODUCTION

2-2. This section includes information on initial inspection, preparation for use, and storage/shipment of the HP Model 8503B.

2-3. INITIAL INSPECTION

2-4. Inspect the shipping container for damage. If the shipping container or cushioning material is damaged it should be kept until the contents of the shipment have been checked for completeness and the instrument has been checked mechanically and electrically. The contents of the shipment should be as shown in Figure 1-1. Procedures for checking electrical performance are given in Section IV. If the contents are incomplete, if there is mechanical damage or defect, or if the instrument does not pass the electrical performance test, notify the nearest Hewlett-Packard office. If the shipping container is damaged, or the cushioning material shows signs of stress, notify the carrier as well as the Hewlett-Packard office. Keep the shipping materials for carrier's inspection. The HP office will arrange for repair or replacement without waiting for claim settlement.

2-5. PREPARATION FOR USE

2-6. Power Requirements

2-7. The Model 8503B requires a power source of 100, 120, 220, or 240 Vac $\pm 5\%$ - 10% , 50 or 60 Hz single phase. Power consumption is less than 10 volt-amperes.

2-8. Line Voltage and Fuse Selection

WARNING

BEFORE THIS INSTRUMENT IS SWITCHED ON, its protective earth terminals must be connected to the

protective conductor of the mains power cable (cord). The mains power cable plug shall only be inserted in a socket outlet provided with a protective earth contact. DO NOT negate the earth-grounding protection by using an extension cable, power cable, or autotransformer without a protective ground conductor. Failure to ground the instrument properly can result in serious personal injury.

CAUTION

BEFORE SWITCHING ON THIS INSTRUMENT, make sure it is adapted to the voltage of the ac power source. You must set the voltage selector card correctly to adapt the 8503B to the power source. Failure to set the ac power input of the instrument for the correct voltage level could cause damage to the instrument when switched on.

2-9. Select the line voltage and fuse as follows:

- a. Measure the ac line voltage.
- b. Refer to Figure 2-1. At the instrument's rear panel power line module, select the line voltage (100V, 120V, 220V, 240V) closest to the voltage you measured in step a. Line voltage must be within $\pm 5\%$ or $\pm 10\%$ of the voltage setting. If it is not, you must use an autotransformer between the ac source and the 8503B.
- c. Make sure the correct fuse is installed in the fuse holder. The required fuse rating for each line voltage selection is indicated below the power line module.

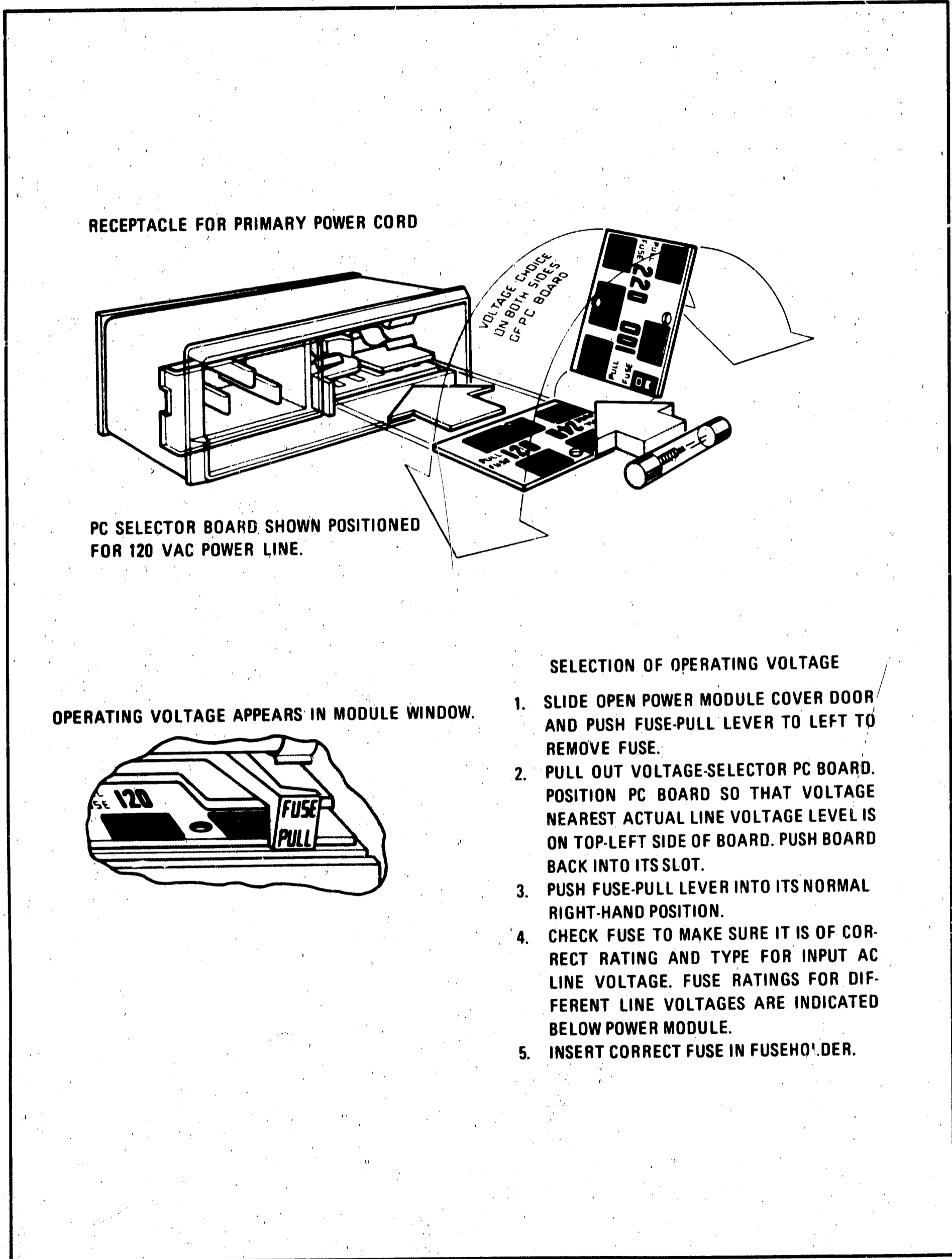

Figure 2-1. Line Voltage Selection with Power Module PC Board

2-10. Cable Connections

2-11. Power Cable. In accordance with international safety standards this instrument is equipped with a three-wire power cable. When connected to an appropriate power line outlet, this cable grounds the instrument cabinet. Figure 2-2 shows the styles of mains plugs available on power cables supplied with HP instruments. The HP part numbers shown with each plug are the part numbers for the complete power cable.

WARNING

If this instrument is to be energized through an autotransformer, make sure the common terminal of the autotransformer is connected to the protective earth contact of the power source outlet socket.

Any interruption of the protective ground, inside or outside of the 8503B can make the 8503B an electrical shock hazard.

2-12. Signal Processor Interconnect Cable. Connect Signal Processor interconnect cable (HP

Part Number 08503-60005) from 8503B rear-panel SIGNAL PROCESSOR INTERCONNECT (A10J2) to 8505A rear-panel TEST SET INTERCONN. (A3J3).

2-13. HP-IB Cable (Option 001 Only). Connect HP-IB cable (HP Part Number 10631A) from 8503B Option 001 rear-panel HP-IB connector (A10J3) to 8505A Option 001 rear-panel HP-IB connector.

2-14. RF Connecting Cables. Connect four short cables (HP Part Number 8120-2289) between 8503B and 8505A corresponding front-panel connectors; i.e., RF to RF, R to R, A to A, and B to B.

NOTE

If RFI is a critical consideration, use semi-rigid coax for RF connecting cables.

2-15. Mating Connectors

2-16. A list of connectors on the front and rear panels of the Model 8503B is given in Table 2-1.

Table 2-1. Model 8503B Mating Connectors

Connector on Instrument	Mating Connector		
	Industry Identification	HP Part No.	Alternate Sources
J1 RF J2 R J3 A J4 B	50Ω Type N male connector UG-21G/U	1250-0882	Amphenol Bendix Specialty Connector
A2J1 Port 1 A3J1 Port 2	75Ω Type N male connector	With mating pin diameter $\frac{.036}{.037}$. All length dimensions same as 50Ω Type N male connector (1250-0882)	
J5 Bridge Bias 1 J6 Bridge Bias 2	50Ω Type BNC male connector UG-88/U	1250-0256	Amphenol Bendix Specialty Connector
A10J2 Interconnect cable connector	Series D 25-contact male connector	1251-0063	Cinch Cannon
A10J3 HP-IB	HP-IB Cable	10631A/B/C*	None
*HP-IB cable 10631A is approximately 1 metre long; 10631B, 2 metres long; 10631C, 4 metres long.			





Plug Type	HP Part Number	Plug Description	Cable Length (inches)	Cable Color	For Use In Country
	8120-1351 8120-1703	Straight 90°	90 90	Mint Gray Mint Gray	Great Britain Cyprus, Nigeria Rhodesia Singapore So. Africa, India
	8120-1369 8120-0696	Straight 90°	79 87	Gray Gray	Australia New Zealand
	8120-1689 8120-1692	Straight 90°	79 79	Mint Gray Mint Gray	East and West Europe, Saudi Arabia, United Arab Republic (unpolarized in many nations)
	8120-1348 8120-1398 8120-1754	Straight 90° Straight	80 80 36	Black Black Black	United States Canada Japan (100 or 200V) Mexico Phillippines Taiwan
	8120-1378 8120-1521 8120-1676	Straight 90° Straight	80 80 36	Jade Gray Jade Gray Jade Gray	
	8120-2104	Straight	79	Gray	Switzerland

Figure 2-2. AC Power Cables Available

2-17. Operating Environment

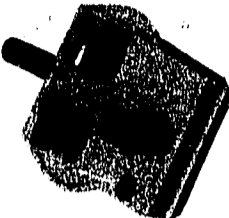
2-18. The operating environment should be within the following limitations:

Temperature 0°C to +55°C
 Humidity Up to 95% relative
 Altitude 4572 metres (15,000 feet)

2-19. Installation Instructions

2-20. General. When used with the 8505A Network Analyzer, the S-Parameter Test Set may be positioned under or on top of the network analyzer (under is preferred position). Where the test set is on the bottom, use four short (19 cm) RF connecting cables, HP Part Number 8120-2289, supplied with the 8503B. When the test set is on top, the 11851A cable kit is required to provide RF connections between 8505A and 8503B.

2-21. 8505A Operating Instruction Sheet. When the 8503B is under the network analyzer and the short RF connecting cables are used, the 8505A Operating Instruction Sheet must be removed from the bottom of the 8505A and installed on the bottom of the 8503B. To accomplish this, proceed as follows:

- a. Set the 8505A on its left side (facing the front panel) and remove the two plastic feet from the right side of the instrument as shown in Figure 2-3. To remove feet, lift tabs and slide in direction of arrows.
- b. Remove 8505A Operating Instruction Sheet (in its housing) and reinstall the two plastic feet which were removed in step a. Make certain that the tabs are all the way down against the bottom cover before returning the 8505A to its normal position.
- c. Set the 8503B on its left side and remove the two plastic feet from the right side of the instrument as shown in Figure 2-3.
- d. With the 8505A Operating Instruction Sheet (and its housing) oriented so the instruction sheet will pull out toward the front of the 8503B, insert the two bottom metal tabs on the instruction sheet housing under the two bottom feet of the 8503B (the tab near the front panel is inserted in the small slot between the front frame and the plastic foot). See Figure 2-3.
- e. Reinstall the two plastic feet which were removed in step c. Make certain that the tabs are all the way down against the bottom

cover and that the operating instruction sheet housing is secured by all four feet before returning the 8503B to its normal position.

2-22. Locking Units Together. If you want to lock the 8503B and the 8505A together, use the hardware provided and proceed as follows:

- a. Remove the 8503B front frame top trim strip (see Figure 6-2, item 5).
- b. Fasten the four lock links (HP Part Number 1600-0367) to the 8503B front frame using the eight 6-32 pozidrive screws provided (there are eight threaded holes in the front frame). The hook-shaped protrusions of the lock links must extend toward the rear of the 8503B.
- c. Remove the two bottom rear feet from the 8505A (lower unit) and replace with two lock feet which contain thumb screws. There is a left one (HP Part Number 08505-20155) and a right one (HP Part Number 08505-20157). See Figure 2-4 for proper placement.
- d. Set the 8505A on its side and remove the four bottom feet. To remove feet, lift tabs and slide in direction of arrows.
- e. Remove the two top rear feet from the 8503B and replace with lower left rear lock foot (HP Part Number 08505-20156) and lower right rear lock foot (HP Part Number 08505-20158). See Figure 2-4 for proper placement.
- f. Set the 8505A Network Analyzer on top of the 8503B S-Parameter Test Set with the front edge of the 8505A overhanging the front edge of the 8503B approximately 1/4 inch.
- g. Slide the 8505A back until its front edge is even with the front edge of the 8503B. This should lock the fronts of the two units together. Make sure they are locked by carefully lifting the front of the 8505A.
- h. Tighten the thumb screws on the upper rear lock feet of the 8505A into the lower rear lock feet of the 8503B.

2-23. Bench Operation

2-24. The instrument cabinet has plastic feet and foldaway tilt stands for convenience in bench operation. The tilt stands raise the front of the instrument for easier viewing of the control panel, and the plastic feet are shaped to make full width modular instruments self-aligning when stacked.

2-25. Rack Mounting (Option 908/909)

2-26. Instruments with Option 908 contain a Rack Flange Kit. This kit supplies the hardware and installation instructions needed to prepare the instrument for mounting on a rack of 482.6 mm (19 inch) spacing. Installation instructions are also given in Figure 2-5. See Table 2-2 for HP Part Numbers.

2-27. Instruments with Option 909 contain a Rack Flange Front Handle Kit. This kit supplies the hardware and installation instructions needed to prepare the instrument, with the addition of front handles, for mounting on a rack of 482.6 mm (19 inch) spacing. Installation instructions are also given in Figure 2-5.

2-28. Front Handles (Option 907)

2-29. Instruments with Option 907 contain a front Handle Kit. This kit supplies the hardware and installation instructions for mounting front

handles on the instrument. Installation instructions are also given in Figure 2-5.

2-30. INCOMING INSPECTION TEST

2-31. This test is designed to meet the needs of incoming inspection. The procedures shown in Figure 2-6 test the critical specifications of the HP Model 8503B S-Parameter Test Set. Equipment required to perform the incoming inspection is listed in Table 1-6. If substitution is necessary for any of the equipment, the alternate models must meet or exceed the critical specifications listed in Table 1-6.

2-32. The incoming inspection test verifies only the critical specifications of the instrument. If complete certification is required, use the more detailed procedures in Section IV which test all of the instrument's specifications.

2-33. STORAGE AND SHIPMENT

2-34. Environment

2-35. The instrument should be stored in a clean, dry environment. The following environmental limitations apply to both storage and shipment.

Temperature -40°C + 75°C
 Humidity Up to 95% relative
 Altitude 15240 metres (50,000 feet)

Table 2-2. Rack-Mounting Kits for 8503B

Description	HP Part Number	Quantity
OPTION 908 Rack Flange	5020-8861	2
Machine Screw, Pan Head, 8-32 x 0.375 inch	2510-0193	6
OPTION 909 Handle Assembly	5060-9898	2
Rack Flange	5020-8873	2
Machine Screw, Pan Head, 8-32 x 0.625 inch	2510-0194	6

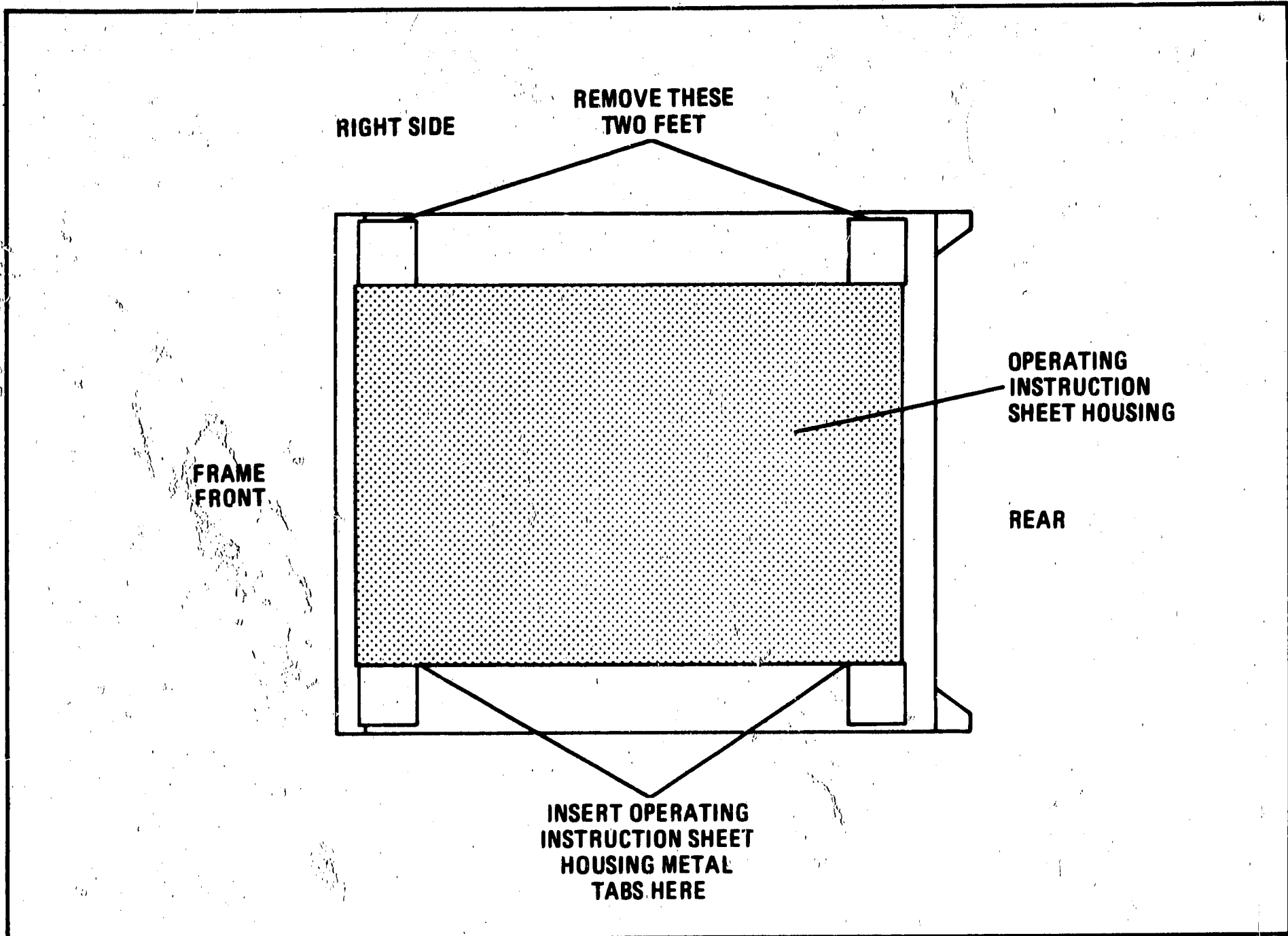

Figure 2-3. Changing 8505A Operating Instruction Sheet to Bottom of 8503B

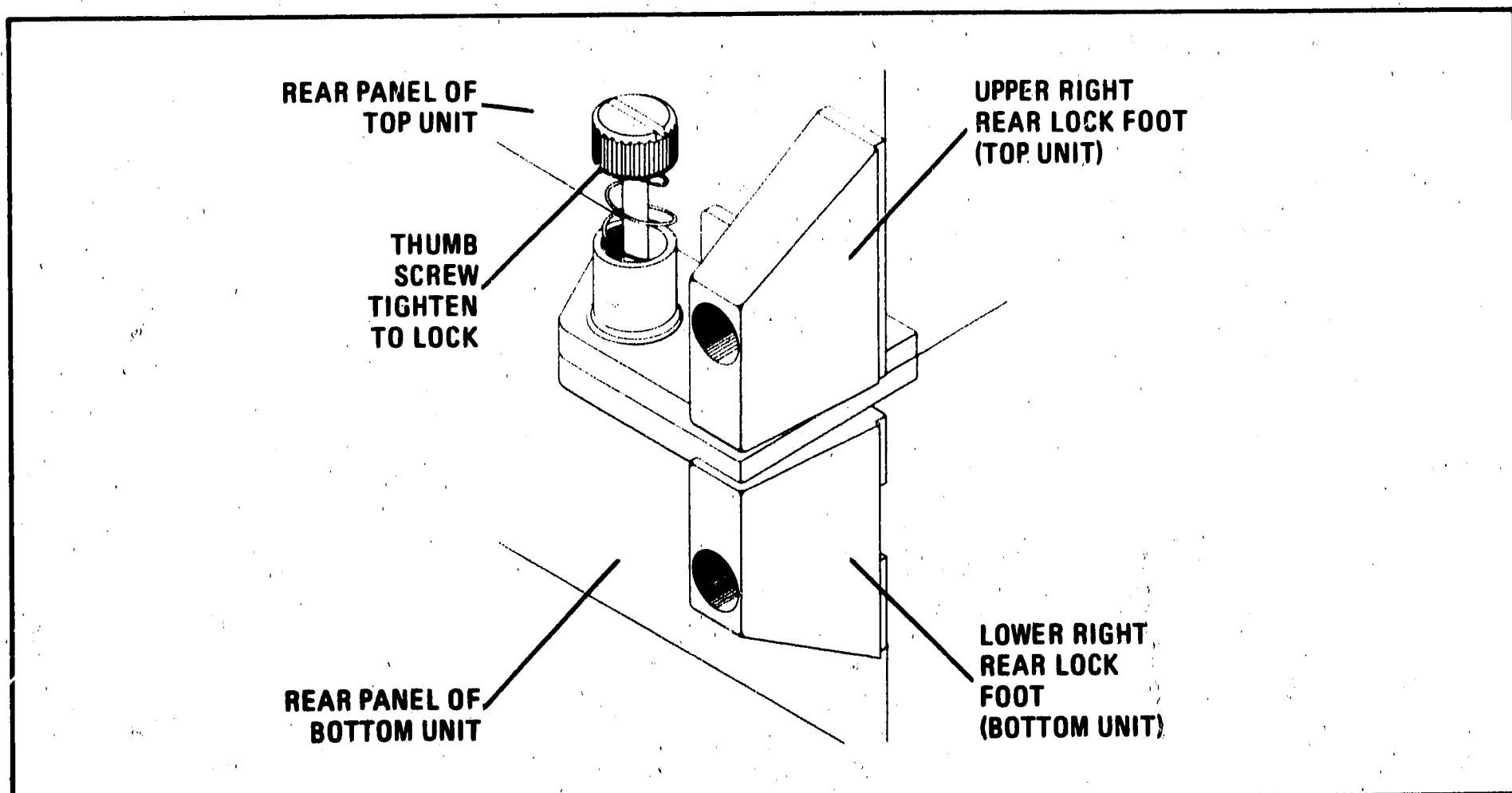

Figure 2-4. Lock Feet, Right Side of Rear Panel

2-36. Packaging

2-37. Original Packaging. Containers and materials identical with those used in factory packaging are available through Hewlett-Packard offices. If the instrument is being returned to Hewlett-Packard for servicing, attach a tag indicating the type of service required, return address, model number, and full serial number. Also, mark the container FRAGILE to ensure careful handling. In any correspondence, refer to the instrument by model number and full serial number.

2-38. Other Packaging. The following general instructions should be used for repackaging with commercially available materials.

- a. Wrap the instrument in heavy paper or plastic. (If shipping to a Hewlett-Packard office

or service center, attach a tag indicating the type of service required, return address, model number, and full serial number.)

- b. Use a strong shipping container. A double-wall carton made of 275 pound bursting strength corrugated single-wall box is sufficient.
- c. Use enough shock-absorbing material (3- to 4-inch layer) around all sides of the instrument to provide a firm cushion and prevent movement inside the container. Protect the control panel with cardboard.
- d. Seal the shipping container.
- e. Mark the shipping container FRAGILE to ensure careful handling.

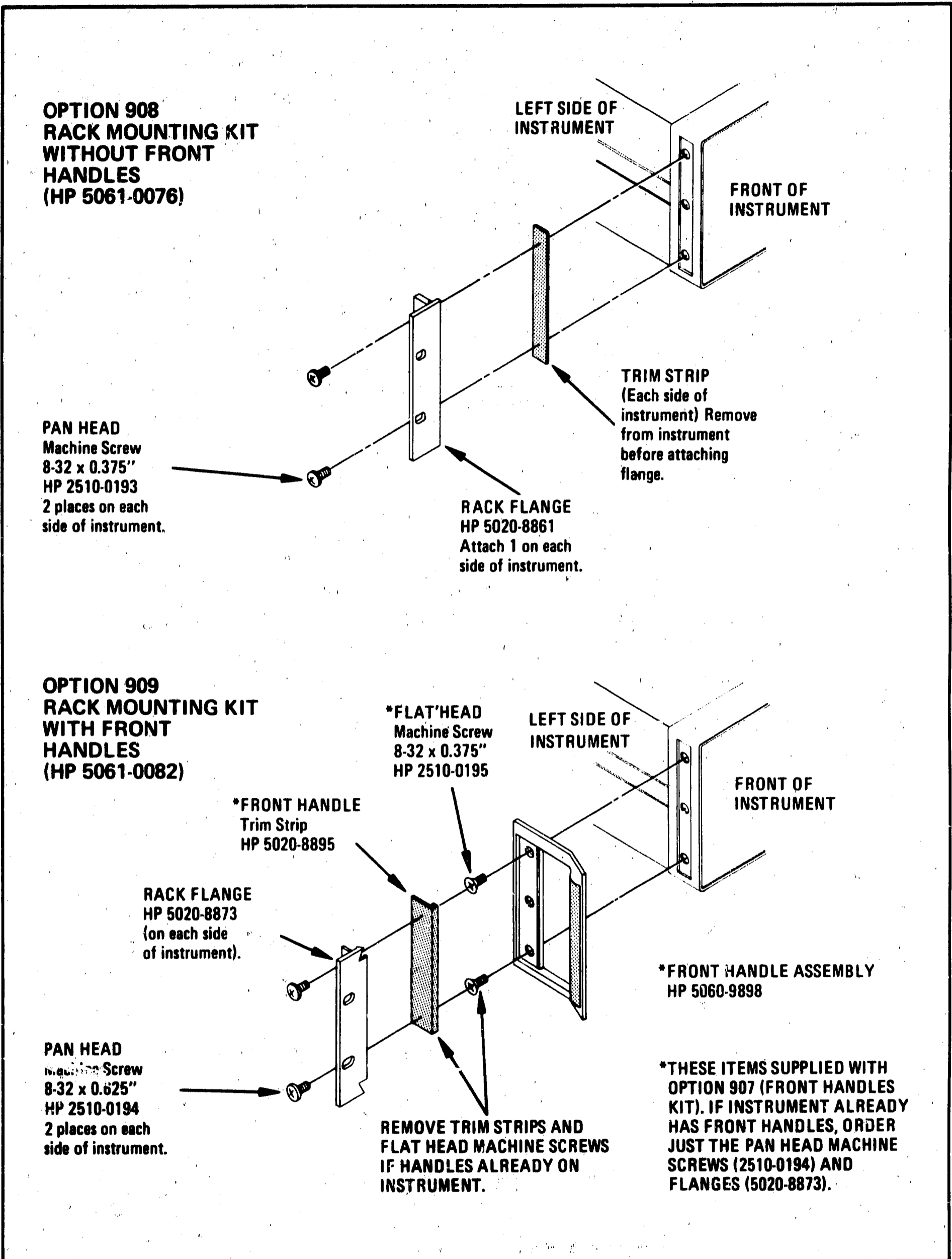
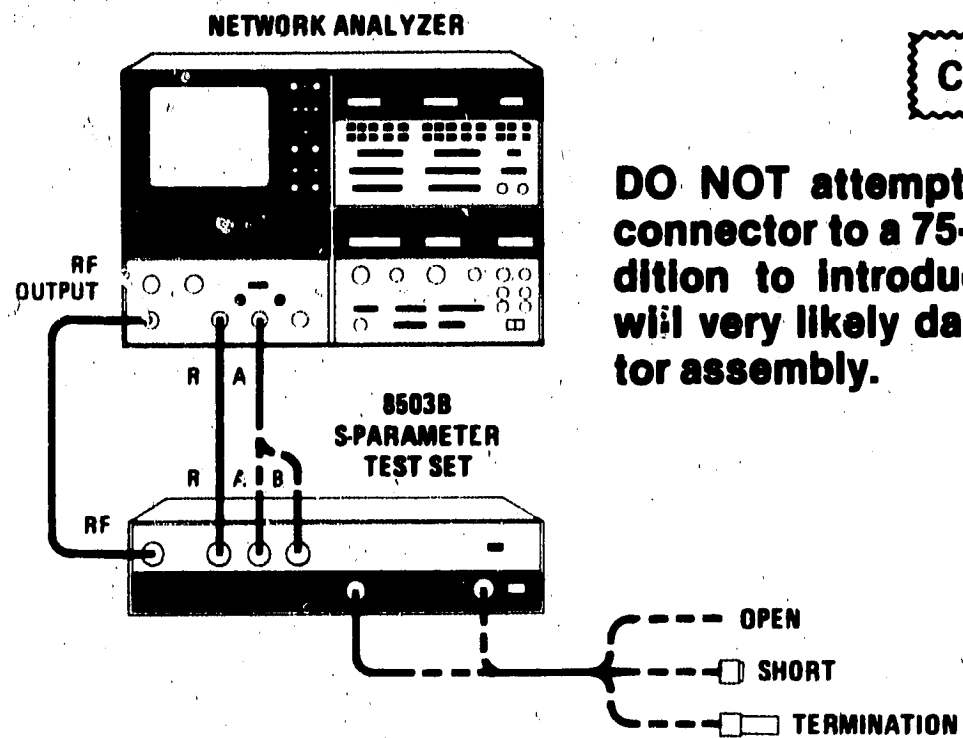

Figure 2-5. Attaching Rack Mounting Hardware and Handles

INCOMING INSPECTION TEST



CAUTION

DO NOT attempt to connect a 50-ohm connector to a 75-ohm output port. In addition to introducing a mismatch, you will very likely damage the port connector assembly.

EQUIPMENT:

- Network Analyzer HP 8505A
- 75A Type N Male Short HP 1250-1530*
- 75Ω Type N Male Termination with
< 1.006 SWR HP 1250-1540**
- * Part of HP 11855A 75A Type N Accessory Kit
- ** Part of HP 85036A 75A Type N Calibration Kit

PROCEDURE:

a. Set 8503B controls as follows:

S-PARAMETER SELECT FORWARD
 LINE ON

b. Set 8505A controls as follows:

Source/Converter:

OUTPUT LEVEL dBm - 10
 OUTPUT LEVEL Vernier 0
 INPUT LEVEL dBm MAX. - 10

Figure 2-6. Incoming Inspection Test (1 of 3)

INCOMING INSPECTION TEST

Frequency Control:

RANGE MHz..... .5 - 1300
 MODE LIN FULL
 WIDTH START/STOP 1
 SCAN TIME SEC 1 - .1
 TRIGGER AUTO
 MARKERS Switch 1
 MARKER 1 Mid-range
 START FREQUENCY 0 MHz
 STOP FREQUENCY 1300 MHz

Signal Processor:

Channel 1:

INPUT A/R
 SCALE/DIV 20 dB

Channel 2:

MODE OFF

Electrical Length:

MODE OFF

Display Section:

BW 10 kHz
 VIDEO FILTER OFF

- c. Connect equipment as shown in test setup with PORT 1 and PORT 2 open, and 8503B PORT A connected to 8505A PORT A.
- d. On 8505A CRT display, depress REF LINE POSN pushbutton. Adjust CH 1 control until trace is positioned to center of screen. Press REF LINE POSN pushbutton again to return system to normal operation.
- e. Place 8505A Frequency Control MARKER 1 on center graticule line.
- f. To calibrate the system for directivity measurements, connect coaxial short directly to PORT 1 of the 8503B. On 8505A Signal Processor Channel 1, press DISPLAY MKR then ZRO pushbuttons to place maker on reference line and to zero digital readout.

NOTE

In the following step, the termination must be properly seated in the connector with the tightening nut correctly aligned. If the termination is not properly seated, low directivity will be measured, and the measurement will not be repeatable.

Figure 2-6. Incoming Inspection Test (2 of 3)

INCOMING INSPECTION TEST

- g. To measure the directivity of the 8503B, remove coaxial short and replace it with a 75Ω termination (HP1250-1540). The SWR of the termination must be ≤ 1.006 (50.5 dB Return Loss).
- (1) Set 8505A Frequency Control MARKER 1 to worst-case directivity as indicated on CRT (the point closest to calibration line as shown in the waveform).
 - (2) Read worst-case directivity from 8505A Signal Processor Channel 1 digital display. The indication should be ≥ 40 dB below the 0 dB reference level.

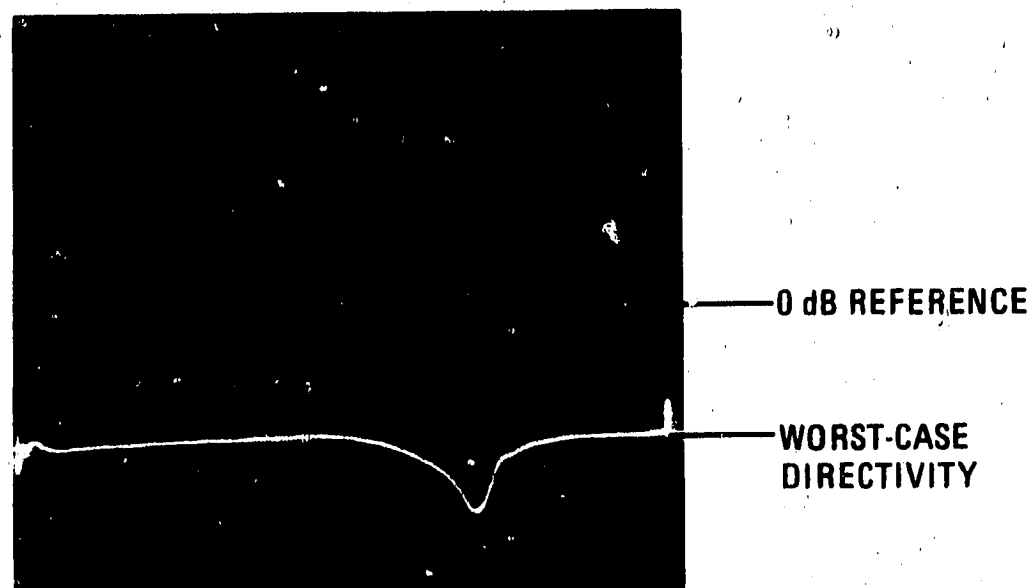
**NOTE**

If the worst-case directivity appears to be less than 40 dB, remove termination. Observe the 8505A digital marker readings with Test Port open, then shorted. The average value between the digital marker readings (open and shorted) is the true reference at that frequency. Replace the termination. The directivity is the difference between the true reference and the digital reading taken with the termination connected.

- h. Connect 8503B Port B to 8505A INPUT A.
- i. Set 8503B S-PARAMETER SELECT switch to REVERSE.
- j. Repeat steps e through g for PORT 2 (connect short to PORT 2 instead of PORT 1 in step f).

Figure 2-6. Incoming Inspection Test (3 of 3)

OPERATION

SECTION III OPERATION

3-1. INTRODUCTION

3-2. This section explains the functions of the Model 8503B S-Parameter Test Set's controls and indicators, and describes typical ways to use the 8503B in a measurement system.

3-3. PANEL FEATURES

3-4. Front and rear panel features of the test set are described in Figure 3-1. Numbers in the text match the numbers in the illustration.

3-5. OPERATOR'S CHECKS

3-6. The Operator's Checks given in Figure 3-2 enable the user to quickly evaluate the instrument's main functions prior to its employment in a test system.

3-7. OPERATING INSTRUCTIONS

3-8. Figure 3-3 shows the RF signal path through the test set for each of the four S-parameter measurements. General operating procedures, in

which the 8503B is used with the 8505A Network Analyzer, are given in Figures 3-4 through 3-6. If you are using the 8503B in an 8507A Automatic Network Analyzer System, the operating procedures are the same, except that the 8503B Option 001 transfer switch (FORWARD/REVERSE) can be controlled by the Hewlett-Packard INTERFACE Bus (HP-IB).

3-9. FUSES

3-10. The 8503B has three fuses, two of them inside the instrument and one, the ac line fuse, in the power module on the rear of the instrument. Only the ac line fuse may be replaced by the operator. The internal fuses are accessible only when the top cover of the instrument is removed. They should be replaced only by a qualified service technician.

3-11. To replace the ac fuse, disconnect the ac line cord from the power source and then from the instrument's power module. With the ac power removed, replace the fuse as shown in Figure 2-1 of the Installation Section.

FRONT AND REAR PANEL FEATURES

FRONT

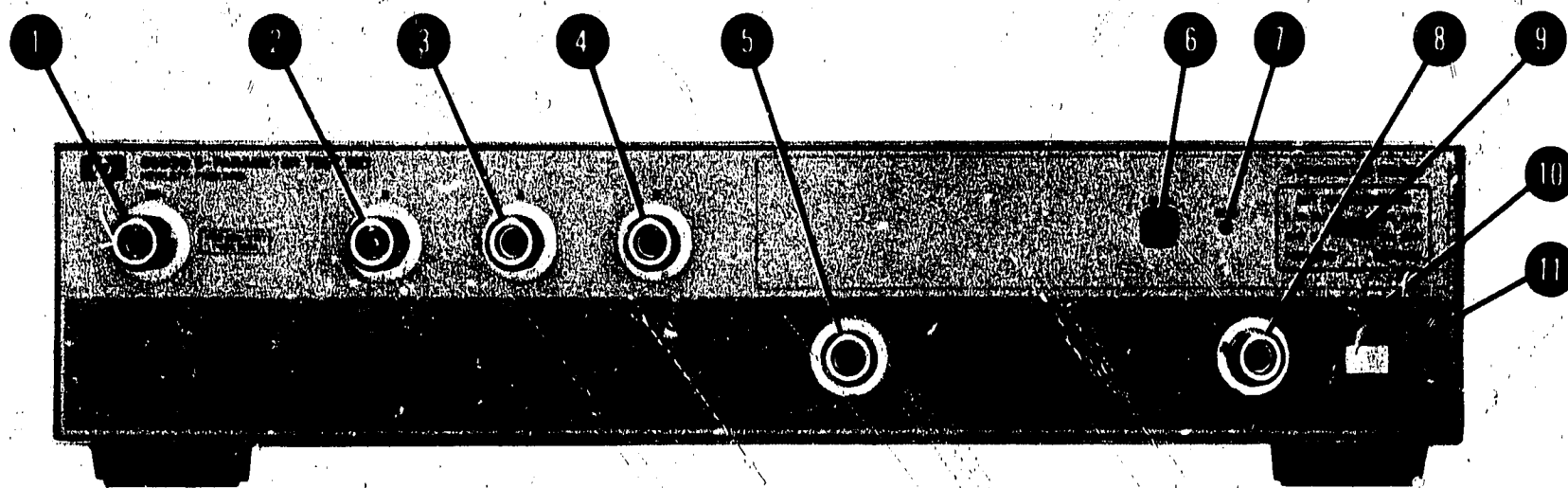

REAR

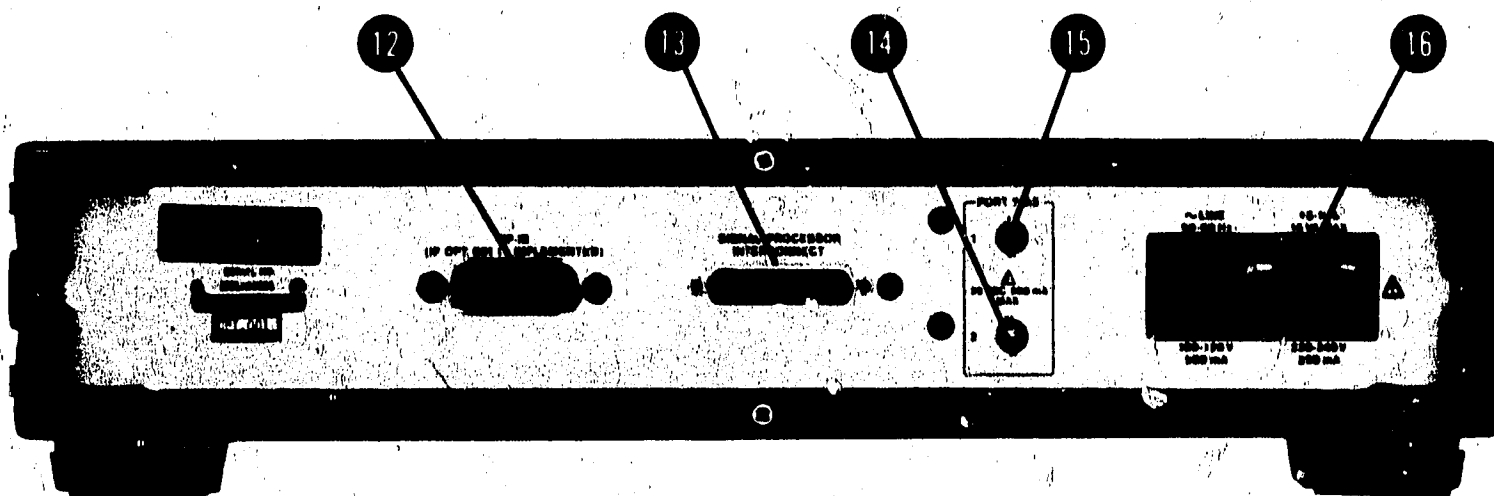

Figure 3-1. Front and Rear Panel Controls, Connectors, and Indicators (1 of 3)

FRONT AND REAR PANEL FEATURES

- ① **RF Input Connector.** Provides input connection for RF signal from Source/Converter of 8505A Network Analyzer or similar RF source.

CAUTION

Do not exceed +30 dBm (1 watt) or 7 Vdc maximum input to the RF input connector. If these levels are exceeded, severe damage to the instrument may result.

- ② **Port R.** Provides reference signal to port R of 8505A, or to the reference port of a similar network analyzer.

- ③ **Port A.** Provides an RF signal to port A of 8505A. The RF signal at 8503B port A is dependent on position of S-PARAMETER SELECT switch ⑨ or calculator program (8503B Option 001). The port A output may also be used as a measurement channel input for a network analyzer similar to the 8505A.

- ④ **Port B.** Provides signal to port B of 8505A. The RF signal at 8503B port B is dependent on position of S-PARAMETER SELECT switch ⑨ or calculator program (8503B Option 001). The port B output may also be used as a measurement channel input for a network analyzer similar to the 8505A.

- ⑤ **PORT 1.** The device under test is connected directly or indirectly (through special cables or fixtures) to PORT 1 (or PORT 2 ⑧), or both test ports ⑤ and ⑧).

CAUTION

Do not exceed +26 dBm or 30 Vdc maximum input to PORT 1 or PORT 2. If these levels are exceeded, severe damage to instrument may result.

- ⑥ **LOCAL Pushbutton Switch.** Functional only in instruments with Option 001. It overrides the REM (remote) signal line from the calculator and returns the 8503B Option 001 to LOCAL mode. Once the LOCAL pushbutton switch is pressed, the 8503B Option 001 will remain in LOCAL mode until programmed to REMote by the operator.

- ⑦ **REM Indicator.** Functional only in instruments with Option 001. The REM indicator is on when the 8503B Option 001 is in REMote mode. In the REM Mode, the transfer switch (FORWARD/REVERSE) is controlled by the calculator rather than the S-PARAMETER SELECT switch ⑨.

- ⑧ **PORT 2.** The device under test is connected directly or indirectly (through special cables or fixtures) to PORT 2 (or PORT 1 ⑤), or both test port ⑤ and ⑧). PORT 2 adjusts laterally to allow for slightly different port spacing of test fixtures.

Figure 3-1. Front and Rear Panel Controls, Connectors, and Indicators (2 of 3)

FRONT AND REAR PANEL FEATURES

CAUTION

Do not exceed +26 dBm or 30 Vdc maximum input to PORT 1 or PORT 2. If these levels are exceeded, severe damage to instrument may result.

- 9 **S-PARAMETER SELECT Switch.** Selects s-parameters to be measured (FORWARD direction or REVERSE direction).
- 10 **LINE-ON Indicator.** Lights when ac power is applied to the 8503B through the LINE OFF-ON switch 11 (ON Position) and the +5 Vdc power supply is providing +5 volts.
- 11 **LINE OFF-ON Switch.** In the ON position (right side of switch pressed), ac power is applied to the 8503B and the LINE ON indicator 10 lights. In the OFF position (left side of switch pressed), no ac power is applied to the 8503B through the LINE OFF-ON switch and the LINE ON indicator 10 is not lighted.
- 12 **HP-IB Connector A10J3.** The rear-panel HP-IB connector is functional only in instruments with Option 001. This connector provides for connection of cable (HP 10631A) from 8503B Option 001 to other HP-IB instruments.
- 13 **SIGNAL PROCESSOR INTERCONNECT Connector A10J2.** Provides an interface between the 8503B and the 8505A Signal Processor. With the Signal Processor Interconnect Cable (HP Part Number 88503-60005) con-

nected properly, the 8505A "remembers" the settings and calibrations of the 8503B to provide current and stored information on the 8505A CRT display.

- 14 **PORT BIAS 1 BNC Connector.** Provides for dc bias to PORT 1 13. The dc source applied at this connector is used to bias device under test connected to PORT 1.

CAUTION

Do not exceed 30 Vdc or 500 mA maximum input to PORT BIAS connector. If these levels are exceeded, damage to the instrument may result.

- 15 **Port BIAS 2 BNC Connector.** Provides for dc bias to PORT 2 14. The dc source applied at this connector is used to bias device under test connected to PORT 2.

CAUTION

Do not exceed 30 Vdc or 500 mA maximum input to PORT BIAS connector. If these levels are exceeded, damage to the instrument may result.

- 16 **Power Line Module FL1 and Fuse F1.** Line Voltage Selector PC board allows selection of 100, 120, 220, or 240 VAC OPERATION. Instructions for line voltage selection and changing fuses are given in Section II.

Figure 3-1. Front and Rear Panel Controls, Connectors, and Indicators (3 of 3)

OPERATOR'S CHECKS

2. Set 8505A and 8503B LINE switches 21 and 24 to ON. On 8505A, LED displays should light. On 8503B, LINE ON indicator 23 should light.

3. Set 8505A controls as follows:

Source/Converter:

OUTPUT LEVEL dBm 1 -10
 OUTPUT LEVEL Vernier 2 0
 INPUT LEVEL dBm MAX 3 -10

Frequency Control:

RANGE MHz 305 — 1300
 MODE 29 LIN FULL
 WIDTH 25 START/STOP 1
 SCAN TIME SEC 281 — .01
 TRIGGER 26 AUTO
 MARKERS Switch 19 1
 MARKER 1 Mid-Range
 START FREQUENCY 31 0 MHz
 STOP FREQUENCY 27 1300 MHz

Signal Processor:

Channel 1:

INPUT 10 A/R
 MODE 18 MAG
 SCALE/DIV 20 1 dB

Channel 2:

INPUT 11 A/R
 MODE 16 PHASE
 SCALE/DIV 17 90 DEG

Electrical Length:

INPUT 12 A
 MODE 13 X10

4. Set 8503B S-PARAMETER SELECT switch 22 to FORWARD.

Figure 3-2. Operator's Checks (2 of 5)

OPERATOR'S CHECKS

5. On 8505A CRT display, press REF LINE POSN pushbutton ⑦. Adjust CH 1 and CH 2 controls ⑤ and ⑨ until traces are positioned to center of screen. Press REF LINE POSN pushbutton again to remove reference lines.
6. On 8505A Signal Processor, press LENGTH pushbuttons and adjust VERNIER A control ⑪ to display a horizontal trace of phase on CRT ①.
7. On 8505A Signal Processor, press DISPLAY MKR then ZRO for Channel 1 and Channel 2. The CRT display should be similar to that shown below.

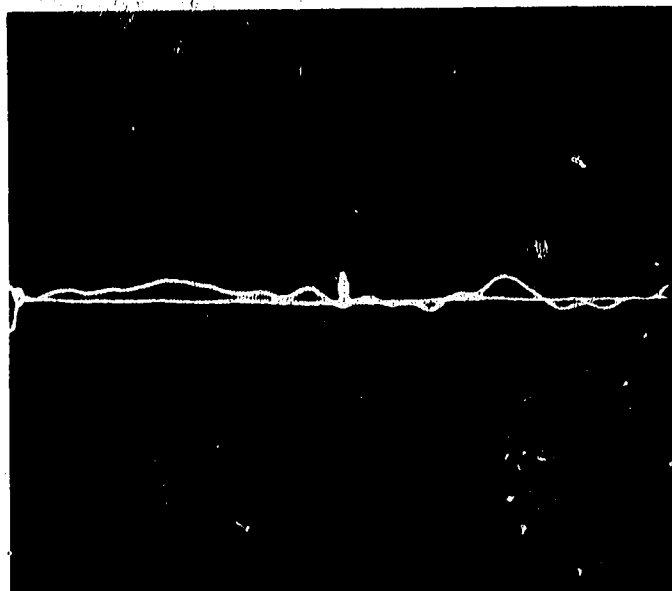

Waveform Showing Magnitude and Phase of S_{11}

8. On 8505A Signal Processor, set Channel 1 and Channel 2 INPUT switches ⑩ and ⑪ to B/R and set Electrical Length INPUT switch ⑫ to B.
9. On 8503B, set S-PARAMETER SELECT switch ⑬ to REVERSE.
10. On 8505A Signal Processor, press LENGTH Pushbuttons and adjust VERNIER B control ⑭ to display a horizontal trace of phase on CRT ①.
11. On 8505A Signal Processor, press DISPLAY MKR then ZRO for Channel 1 and Channel 2. The waveform on the CRT display should be similar to that shown below.

Figure 3-2. Operator's Checks (3 of 5)

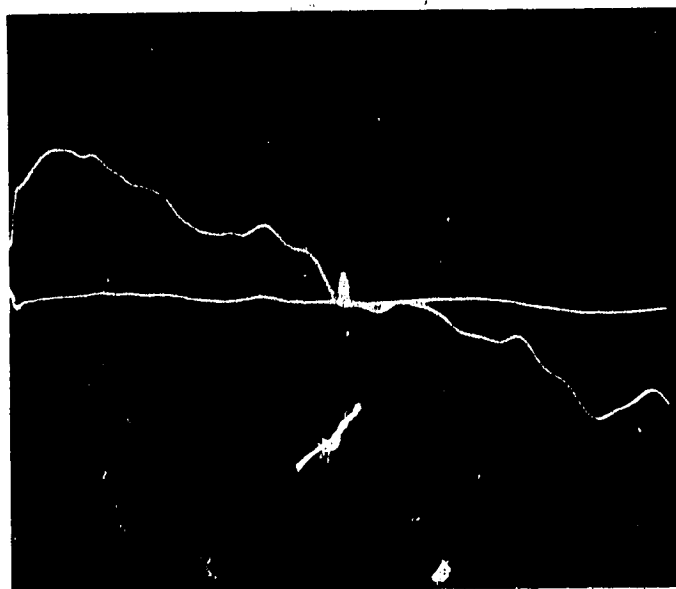
OPERATOR'S CHECKSWaveform Showing Magnitude and Phase of S_{22}

12. Connect thru line (HP 8120-2408*) from PORT 1 to PORT 2 of 8503B. Set S-PARAMETER SELECT switch **22** to FORWARD.
13. On 8505A Signal Processor, press LENGTH pushbuttons and adjust VERNIER B control **15** to display a horizontal trace of phase on CRT **4**.
14. On 8505A Signal Processor, press DISPLAY MKR then ZRO for Channel 1 and Channel 2. The CRT display should be similar to that shown below.

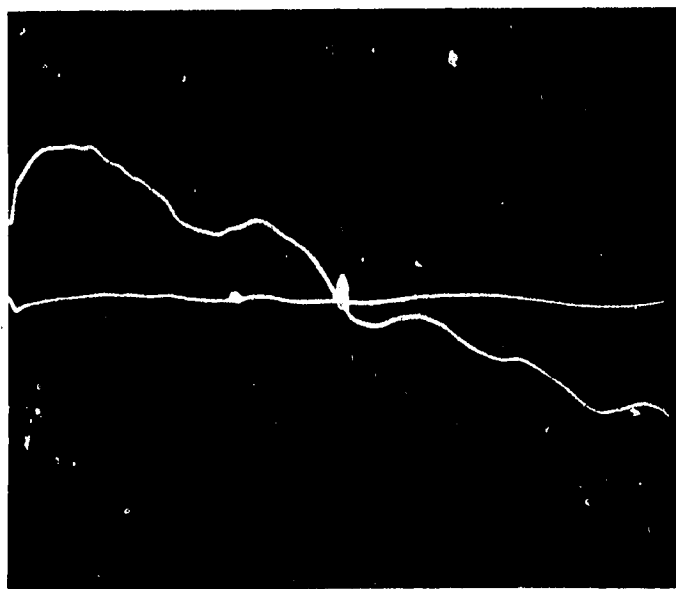
Waveform Showing Magnitude and Phase of S_{21}

* Cable is part of HP Model 11857B Test Port Extender Cable Set.

Figure 3-2. Operator's Checks (4 of 5)

OPERATOR'S CHECKS

15. On 8505A Signal Processor, set Channel 1 and Channel 2 INPUT switches ⑩ and ⑪ to A/R. Set Electrical Length INPUT switch ⑫ to A.
16. On 8503B, set S-PARAMETER SELECT switch ⑳ to REVERSE.
17. On 8505A Signal Processor, press LENGTH pushbuttons and adjust VERNIER A control ⑬ to display a horizontal trace of phase on CRT ④.
18. On 8505A Signal Processor, press DISPLAY MKR then ZRO Channel 1 and Channel 2. The CRT display should be similar to that shown below.

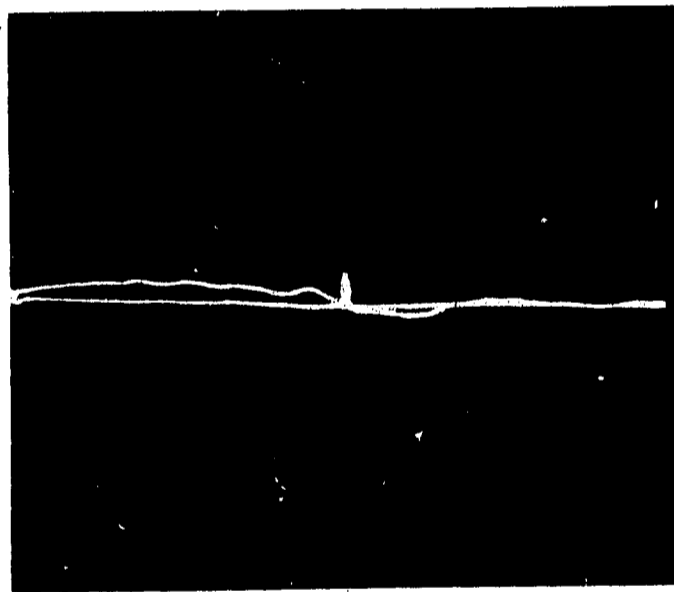

Waveform Showing Magnitude and Phase of S_{12}

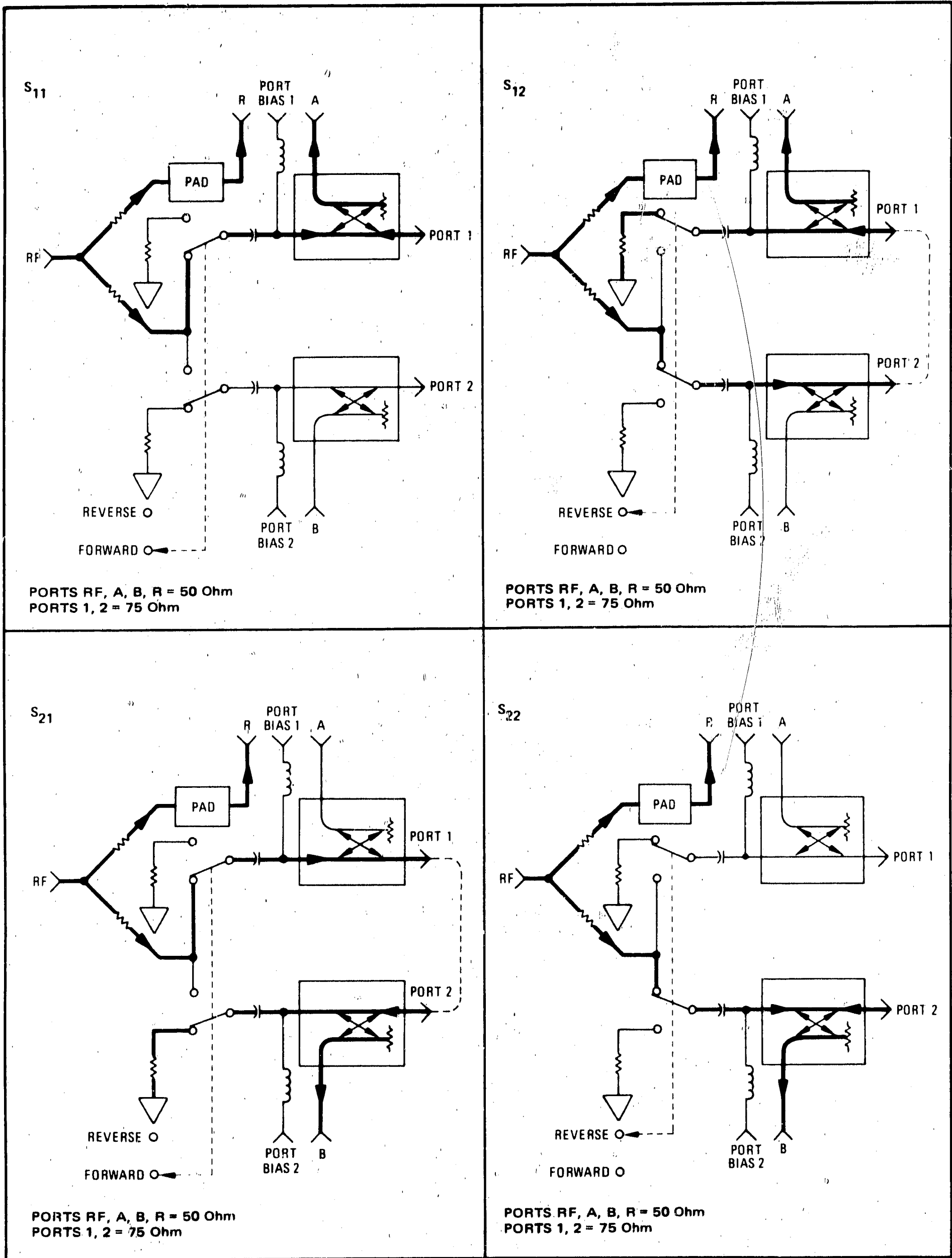
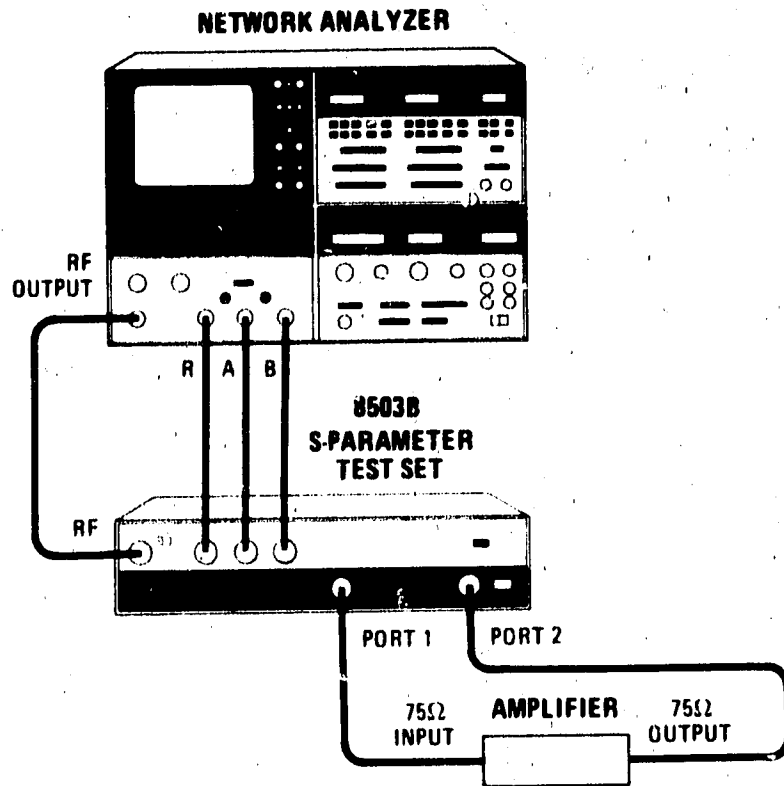

Figure 3-3. RF Signal Path

OPERATING INSTRUCTIONS
AMPLIFIER MEASUREMENT
LOCAL OPERATION



CAUTION

DO NOT attempt to connect a 50-ohm connector to a 75-ohm output port. In addition to introducing a mismatch, you will very likely damage the port connector assembly.

WARNING

BEFORE CONNECTING LINE POWER TO THIS INSTRUMENT make sure all line-powered devices connected to this instrument are connected to the protective (earth) ground.

BEFORE SWITCHING ON THIS INSTRUMENT Make sure line power (mains) plug is connected to a three-conductor line power outlet that has a protective (earth) ground. (Grounding one conductor of a two-conductor outlet is not sufficient.)

1. Connect cables as described in Section II.
2. Set 8505A and 8503B LINE switches to ON and allow at least 3 minutes warm-up time.
3. Set 8503B controls as follows:

Source/Converter:

OUTPUT LEVEL dBm.	- 20
OUTPUT LEVEL Vernier	0
INPUT LEVEL dBm MAX.	- 10

Figure 3-4. Amplifier Measurement Local Operation (1 of 3)

OPERATING INSTRUCTIONS

**AMPLIFIER MEASUREMENT
LOCAL OPERATION**

Frequency Control:

RANGE MHz Desired frequency range
 MODE LIN EXPAND
 WIDTH START/STOP 1
 SCAN TIME SEC 1 — .01
 VERNIER Fully Counterclockwise
 TRIGGER AUTO
 MARKERS Switch 1
 MARKER 1 Mid-Range
 START FREQUENCY Lowest frequency desired
 STOP FREQUENCY Highest frequency desired

Signal Processor:

Channel 1:

INPUT A/R
 MODE MAG
 SCALE/DIV 10 dB

Channel 2:

MODE OFF

Electrical Length:

INPUT A
 MODE X10

4. To measure parameter S_{11} of the amplifier (input reflection characteristic) proceed as follows:
 - a. With 8503A PORT 1 and PORT 2 open (amplifier not connected), set S-PARAMETER SELECT switch to FORWARD.
 - b. On 8505A CRT display, depress REF LINE POSN pushbutton. Adjust CH 1 and CH 2 controls until traces are positioned to center of screen. Press REF LINE POSN pushbutton again to return system to normal operation.
 - c. Press Channel 1 DISPLAY MKR then ZRO pushbuttons to place marker on reference line and to zero digital readout.
 - d. Connect amplifier as shown in test setup:
 - e. Set MARKER 1 to desired measurement frequency or frequencies and read the magnitude value(s) from Channel 1 MKR digital readout.
 - f. On 8505A Signal Processor, set Channel 1 MODE switch to PHASE. Disconnect amplifier from 8503B test ports.

Figure 3-4. Amplifier Measurement Local Operation (2 of 3)

OPERATING INSTRUCTIONS**AMPLIFIER MEASUREMENT
LOCAL OPERATION**

- g. On 8505A Signal Processor, press LENGTH pushbuttons and adjust VERNIER A control to display a horizontal trace on the CRT.
 - h. Set 8505A Channel 2 SCALE/DIV switch to 5 DEG and readjust LENGTH and VERNIER A control, if necessary, to position average slope of trace parallel to horizontal graticule lines.
 - i. Reconnect amplifier as shown in test setup.
 - j. Set MARKER 1 to desired frequency or frequencies and read the phase value(s) from Channel 1 MKR digital readout.
5. To measure parameter S_{12} of the amplifier (reverse transmission characteristic), set 8503B S-PARAMETER SELECT switch to REVERSE and disconnect amplifier from 8503B test ports. Connect through line (HP 8120-3408 cable) from PORT 1 to PORT 2 and perform steps 1 through 3 and steps 4b through 4j.
 6. To measure parameter S_{21} of the amplifier (forward transmission characteristics; gain), proceed as follows:

NOTE

If amplifier gain is greater than 30 dB, reduce RF input to avoid measurement error due to signal compression.

- a. Perform steps 1 through 3, except set Channel 1 INPUT switch to B/R and set Electrical Length INPUT switch to B. Set S-PARAMETER SELECT switch to FORWARD and connect through line (HP 8120-3408 cable) from PORT 1 to PORT 2.
 - b. Perform steps 4b through 4j.
7. To measure parameter S_{22} of the amplifier (output reflection characteristic), proceed as follows:
 - a. Perform steps 1 through 3 except set Channel 1 INPUT switch to B/R and set Electrical Length INPUT switch to B.
 - b. Set 8503B S-PARAMETER SELECT switch to REVERSE and disconnect amplifier from test ports.
 - c. Perform steps 4b through 4j.

Figure 3-4. Amplifier Measurement Local Operation (3 of 3)

**HP-IB OPTION 001
REMOTE OPERATION**

Capability:

The 8503B Option 001 with Hewlett-Packard Interface Bus allows remote programming of the S-PARAMETER SELECT switch.

Operation:

WARNING

In the following procedure, the instrument's top cover must be removed. Before removing top cover, disconnect all power from 8503B. DO NOT RECONNECT POWER UNTIL TOP COVER HAS BEEN REINSTALLED.

HP-IB Assembly A8 in the 8503B Option 001 contains a switch A8SW1 which must be set for the proper Listen/Talk address.

The preset ASCII address code for the test set is:

	ASCII	DECIMAL EQUIVALENT
TALK =	T	20
LISTEN =	4	20

The five-digit binary address code for the test set is then 10100. The decimal equivalent of this five-bit binary number is 20. Switch A8SW1 consists of seven miniature toggles. They are preset to the five-digit binary number as shown below.

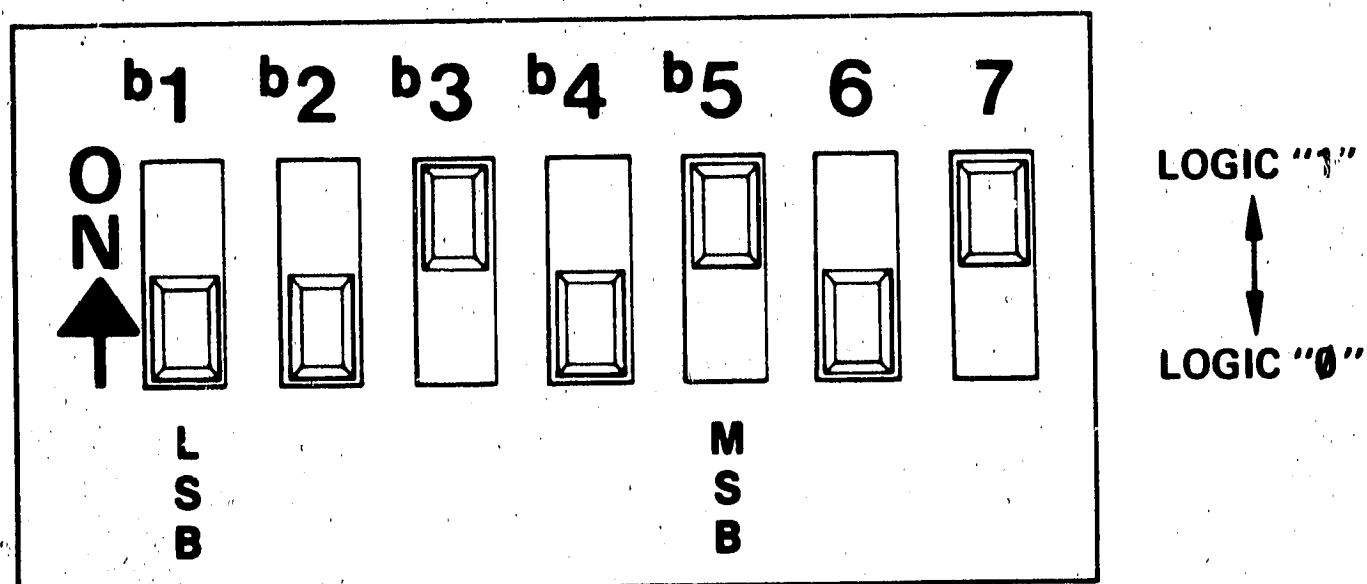

Switch positions 6 and 7 not used.

Figure 3-5. HP-IB Option 001 Remote Operation (1 of 5)

OPERATING INSTRUCTIONS

**HP-IB OPTION 001
REMOTE OPERATION**

If some other address code is desired, refer to Table 3-3 for cross-reference between ASCII code, five-bit binary equivalent, and decimal equivalent.

9830A/B CALCULATOR:

For the Model 9830A or B Calculator, the program format for addressing the test set is as follows:

Table 3-1. Factory Set Address Codes, (9830A/B)

INSTRUMENT	TALK	LISTEN
9830A/B Calculator	U	5
8503B Test Set	T	4

To program the S-Parameter Select Switch to either FORWARD "1" or REVERSE "2" use the following format:

10 CMD "?U4" "1"

Commands unlisten, then calculator talk and test set listen. Then it commands the test set switch to position "1" FORWARD. (REVERSE is "2")

To "LEARN" the state of the S-Parameter Selector switch, the following program may be used:

10 CMD "?U4"
20 FORMAT 3B
30 OUTPUT (13, 20) 256, 1, 512;

} Procedure to "GO to local"

40 CMD "?T5"
50 ENTER (13, *) T

} Commands the calculator to take the switch position data from the test set and store it in "T."

60 PRINT T

Print the position of the Test Set S-Parameter Select switch stored in "T." "1" is FORWARD and "2" is REVERSE.

70 END

Figure 3-5. HP-IB Option 001 Remote Operation (2 of 5)

OPERATING INSTRUCTIONS

**HP-IB OPTION 001
REMOTE OPERATION**

9825A CALCULATOR:

For Model 9825A Calculator, the program format for addressing the test set is as follows:

Table 3-2. Factory Set Address Codes, 9825A

Instrument	HP-IB Interface Select Code	Decimal Equiv. of 5-Bit Binary Number
9825A Calculator	7	21
8503B Test Set	7	20

To program the S-Parameter Select Switch to either FORWARD "1" or REVERSE "2" use the following format:

wrt 720, "1"

Commands the calculator to "write" to the test set a command to set the FORWARD/REVERSE switch to position "1" (FORWARD). Position "2" is REVERSE.

To "LEARN" the state of the S-Parameter Selector switch, use the following program:

0: lcl 720

Commands 8503B to go to local.

1: red 720, T

Commands the calculator to read the position of the FORWARD/REVERSE switch in the test set and store the switch number (1 or 2) in T.

2: prt T

Commands the calculator to print the switch position stored in "T."

3: END

Figure 3-5. HP-IB Option 001 Remote Operation (3 of 5)

OPERATING INSTRUCTIONS**HP-IB OPTION 001
REMOTE OPERATION****HP-IB OPERATION TEST:**

To check that the test set FORWARD/REVERSE switch is actually changing, the following procedure should be followed:

1. Connect the test set to the 8505A network analyzer in a normal setup with nothing connected to port 1 and 2 of the test set. Set 8505A Channel 1 INPUT switch to "A" and set the power output from source to -20 dBm.
2. Command the test set switch to go to "FORWARD" position.
 - a. For Model 9830A/B Calculator:
CMD "?U4 " "1"
 - b. For Model 9825A Calculator:
wrt 720, "1"
3. Verify that the "A" signal displayed on the 8505A CRT is -39 dBm \pm 5.50 dB. Set the 8505A Channel 1 INPUT switch to "B". The signal should be at -130 dBm \pm 25 dB (noise level).
4. Command the test set switch to go to "REVERSE" position.
 - a. For Model 9830A/B Calculator:
CMD "?U4 " "2"
 - b. For Model 9825A Calculator:
wrt 720, "2"
5. Verify that the "B" displayed on the 8505A CRT is -39 dBm \pm 5.5 dB. Set the 8505A Channel 1 INPUT switch to "A". The signal should be at -130 dBm \pm 25 dB (noise level).

OPERATING INSTRUCTIONS

**HP-IB OPTION 001
REMOTE OPERATION**

Table 3-3. Talk and Listen Addresses

Address Switches					Talk Address Character	Listen Address Character	Decimal Equivalent
b ₅	b ₄	b ₃	b ₂	b ₁			
0	0	0	0	0	@	SP	0
0	0	0	0	1	A	!	1
0	0	0	1	0	B	"	2
0	0	0	1	1	C	#	3
0	0	1	0	0	D	\$	4
0	0	1	0	1	E	%	5
0	0	1	1	0	F	&	6
0	0	1	1	1	G	'	7
0	1	0	0	0	H	(8
0	1	0	0	1	I)	9
0	1	0	1	0	J	*	10
0	1	0	1	1	K	+	11
0	1	1	0	0	L	,	12
0	1	1	0	1	M	-	13
0	1	1	1	0	N	.	14
0	1	1	1	1	O	/	15
1	0	0	0	0	P	∅	16
1	0	0	0	1	Q	1	17
1	0	0	1	0	R	2	18
1	0	0	1	1	S	3	19
1	0	1	0	0	T	4	20
1	0	1	0	1	U	5	21
1	0	1	1	0	V	6	22
1	0	1	1	1	W	7	23
1	1	0	0	0	X	8	24
1	1	0	0	1	Y	9	25
1	1	0	1	0	Z	:	26
1	1	0	1	1	[;	27
1	1	1	0	0	\	<	28
1	1	1	0	1]	=	29
1	1	1	1	0	(>	30

PRESET ADDRESS
→

Figure 3-5. HP-IB Option 001 Remote Operation (5 of 5)

PERFORMANCE

CHECK

SECTION IV PERFORMANCE TESTS

4-1. INTRODUCTION

4-2. The procedures in this section test the electrical performance of the instrument using the specifications of Table 1-1 as the performance standards. All tests can be performed without access to the interior of the instrument. A simpler test is included in Section II under Incoming Inspection Test.

4-3. The performance test procedures must be performed in the sequence given, since some procedures rely on satisfactory test results in foregoing steps. If a test measurement is slightly out of tolerance, or if a function fails to operate, perform the troubleshooting procedures in Section VIII.

4-4. EQUIPMENT REQUIRED

4-5. Equipment required for the performance tests is listed in the table of Recommended Test Equipment in Section I. Any equipment that satisfies the critical specifications given in the table may be substituted for the recommended model.

4-6. TEST RECORD

4-7. Results of the performance tests may be tabulated on the Test Record at the end of the procedures. The Test Record lists all the tested specifications and their acceptable limits. Test results recorded at incoming inspection can be used for comparison in periodic maintenance, troubleshooting, and after repairs.

PERFORMANCE TESTS

CAUTION

DO NOT attempt to connect a 50-ohm connector to a 75-ohm output port. In addition to introducing a mismatch, you will very likely damage the port connector assembly.

NOTE

Allow one hour warm-up time for 8505A Network Analyzer before beginning Performance Tests.

4-8. DIRECTIVITY TEST

SPECIFICATION:

Directivity: ≥ 40 dB

DESCRIPTION:

Directivity is tested using the internal coupler to measure the reflection coefficient of a standard termination. The termination return loss is much greater than the directivity, therefore, the resultant measurement is the approximate coupler directivity.

The Directivity Test has been used for the Incoming Inspection Test. The test setup, equipment and procedures needed to test the directivity specifications are in Section II, Figure 2-6, Incoming Inspection Test.

PERFORMANCE TESTS

4-9. TRANSMISSION FREQUENCY RESPONSE TEST**SPECIFICATION:**

Transmission Frequency Response (S_{21} , S_{12}): ± 1 dB, $\pm 12^\circ$ from 0.5 to 1300 MHz (\pm degrees specified as deviation from Linear Phase).

DESCRIPTION:

The frequency response of the 8505A Network Analyzer System is first recorded with a grease pencil on the CRT display. The 8503B is connected and the transmission frequency response is superimposed over the reference grease pencil trace. The difference in the two traces is the transmission frequency response of the 8503B.

CONFIGURATION A

Figure 4-1. Transmission Frequency Response Test Setup (1 of 2)

PERFORMANCE TESTS

4-9. TRANSMISSION FREQUENCY RESPONSE TEST (Cont'd)

CONFIGURATION B

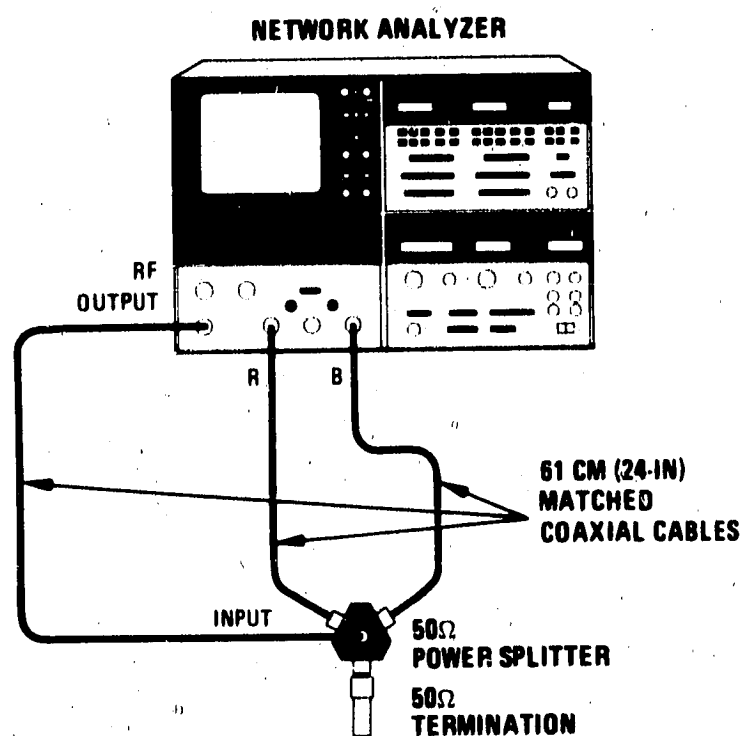
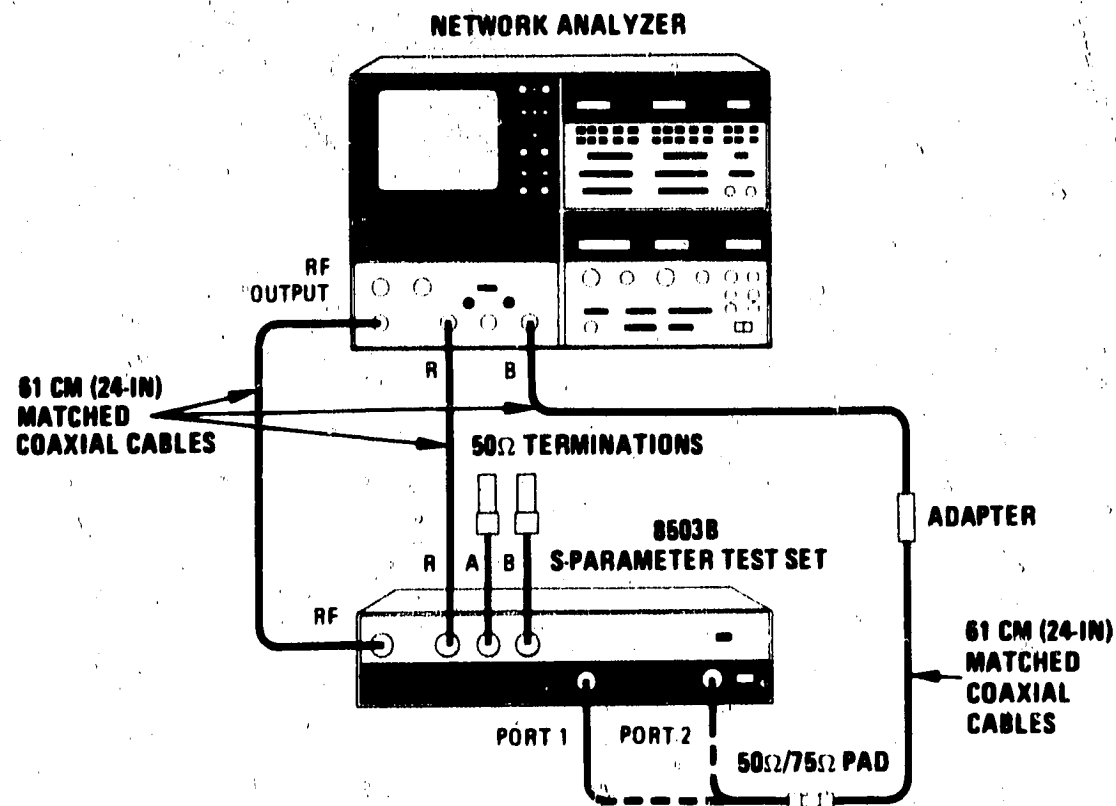

Figure 4-1. Transmission Frequency Response Test Setup (2 of 2)

EQUIPMENT:

Network Analyzer	HP 8505A
3-Way Power Splitter	HP 11850A
50Ω Type N Male Termination (2 required)	HP 909A Option 012
Matched Type N Male Coaxial Cable Kit	HP 11851A
50Ω/75Ω Minimum Loss Pad	HP 11852A
Adapter, Type N Female to Type N Female	HP 1250-0777

PROCEDURE:

- a. Set 8505A controls as follows:

Source/Converter:

OUTPUT LEVEL dBm	-10
OUTPUT LEVEL Vernier	0
INPUT LEVEL dBm MAX	-10

PERFORMANCE TESTS

4-9. TRANSMISSION FREQUENCY RESPONSE TEST (Cont'd)

Frequency Control:

RANGE MHz5 — 1300
 MODE LIN FULL
 WIDTH START/STOP 1
 SCAN TIME SEC 1 — .1
 VERNIER Fully clockwise
 TRIGGER AUTO
 MARKERS Switch 1
 MARKER 1 Mid-range
 START FREQUENCY 0 MHz
 STOP FREQUENCY 1300 MHz

Signal Processor:

Channel 1:
 INPUT B/R
 MODE MAG
 SCALE/DIV2 dB

Channel 2:
 INPUT B/R
 MODE PHASE
 SCALE/DIV 90 DEG

Electrical Length:

INPUT B
 MODE X10

Display Section:

BW 10 kHz
 VIDEO FILTER OFF

- b. Connect equipment as shown in Figure 4-1, Configuration A.
- c. On 8505A CRT display, depress REF LINE POSN pushbutton. Adjust CH 1 and CH 2 controls until traces are positioned to center of screen. Press REF LINE POSN pushbutton again to return system to normal operation.
- d. On 8505A Signal Processor, set Channel 2 MODE switch to OFF.
- e. To record the magnitude frequency response of the Network Analyzer, place 8505A Frequency control MARKER 1 on center graticule line:
 - (1) On the 8505A, press Channel 1 DISPLAY MKR then ZRO pushbuttons to place marker on reference line and to zero digital readout.
 - (2) Grease pencil the trace on the CRT.
- f. To measure the transmission magnitude frequency response of the 8503B, connect equipment as shown in Figure 4-1, Configuration B, with 8503B PORT 1 connected to 8505A INPUT B. Set 8503B S-PARAMETER SELECT switch to FORWARD.
- g. On 8505A, press Channel 1 REF OFFSET pushbuttons to center the display around the grease pencil magnitude trace.

PERFORMANCE TESTS**4-9. TRANSMISSION FREQUENCY RESPONSE TEST (Cont'd)**

- h. Measure the maximum difference between the grease pencil trace and the display trace (Figure 4-2.) This measured value should be $\leq \pm 1$ dB.
- i. Connect 8503B PORT 2 to 8505A INPUT B and set S-PARAMETER SELECT switch to REVERSE. Repeat steps g and h.
- j. To record the phase frequency response of the Network Analyzer, connect equipment as shown in Figure 4-1, Configuration A:
 - (1) Remove CRT grease pencil traces from previous test.
 - (2) Set 8505A Signal Processor Channel 1 MODE switch to OFF and Channel 2 MODE switch to PHASE.
 - (3) On the 8505A Signal Processor, press the LENGTH pushbuttons and adjust VERNIER B control to display a horizontal trace on the CRT.
 - (4) On the 8505A Signal Processor Channel 2 press DISPLAY MKR then ZRO pushbuttons to place marker on reference line and to zero digital readout.
 - (5) Set 8505A Signal Processor Channel 2 SCALE/DIV switch to 2 DEG. Readjust LENGTH and VERNIER B control, if necessary, to position average slope of trace parallel to horizontal graticule lines.
 - (6) Grease pencil the trace on the CRT.

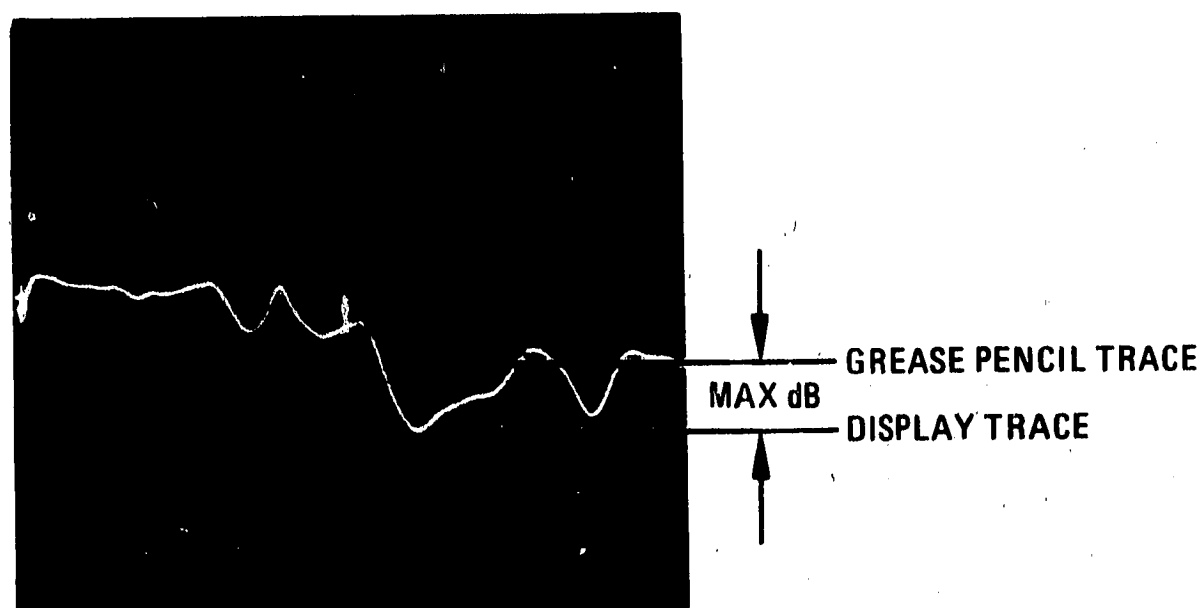

Figure 4-2. Transmission Frequency Response Magnitude

PERFORMANCE TESTS

4-9. TRANSMISSION FREQUENCY RESPONSE TEST (Cont'd)

- k. To measure the transmission phase frequency response of the 8503B, connect equipment as shown in Figure 4-1, Configuration B, with 8503B PORT 2 connected to 8505A INPUT B.
- l. Set 8505A Signal Processor Channel 2 SCALE/DIV switch to 90 DEG.
- m. On 8505A Signal Processor press the LENGTH pushbuttons and adjust VERNIER B control to display a horizontal trace on the CRT. If necessary, press Channel 2 REF OFFSET Pushbuttons to display horizontal trace.
- n. Set 8505A Signal Processor Channel 2 SCALE/DIV switch to 2 DEG. Readjust LENGTH and VERNIER B control, if necessary, to position average slope of trace parallel to horizontal graticule lines.
- o. On the 8505A Signal Processor Channel 2, press the REF OFFSET pushbuttons to center the display around the grease pencil phase trace.
- p. Measure the maximum difference between the grease pencil trace and the display trace (Figure 4-3). This measured value should be $\leq \pm 12^\circ$.
- q. Connect 8503B PORT 1 to 8505A INPUT B and set S-PARAMETER SELECT switch to FORWARD. Repeat steps n through p.
- r. Remove 50-ohm terminations from 8503B Ports A and B.

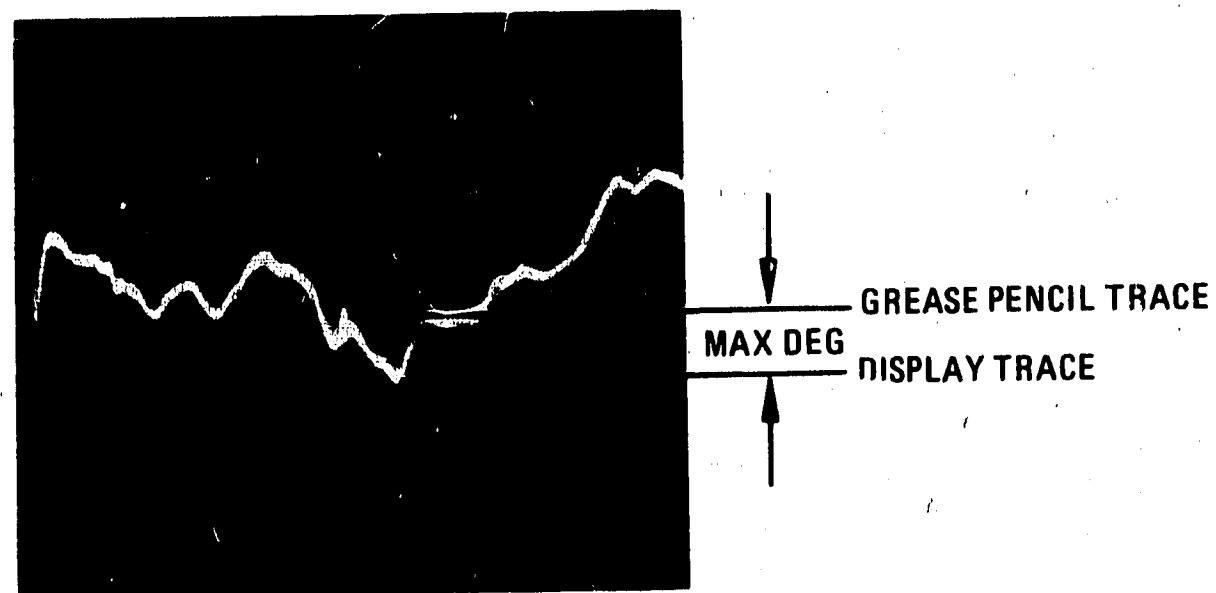

Figure 4-3. Transmission Frequency Response Phase

PERFORMANCE TESTS

4-10. REFLECTION FREQUENCY RESPONSE TEST

SPECIFICATION:

Reflection Frequency Response (S_{11} , S_{22}): ± 2 dB, $\pm 20^\circ$ from 0.5 to 1300 MHz
 $\pm 15^\circ$ from 2 to 1300 MHz

DESCRIPTION:

The reflection frequency response of the 8505A Network Analyzer system is first recorded with a grease pencil on the CRT display. The 8503B is connected and the reflection frequency response is superimposed over the reference grease pencil trace. The difference in the two traces is the reflection frequency response of the 8503B.

CONFIGURATION A

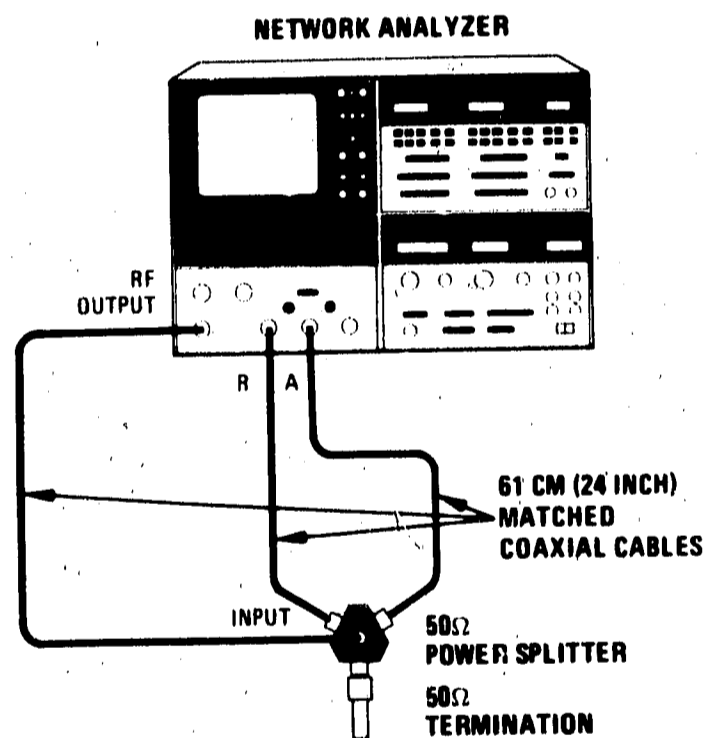

Figure 4-4. Reflection Frequency Response Test Setup (1 of 2)

PERFORMANCE TESTS

4-10. REFLECTION FREQUENCY RESPONSE TEST (Cont'd)

CONFIGURATION B

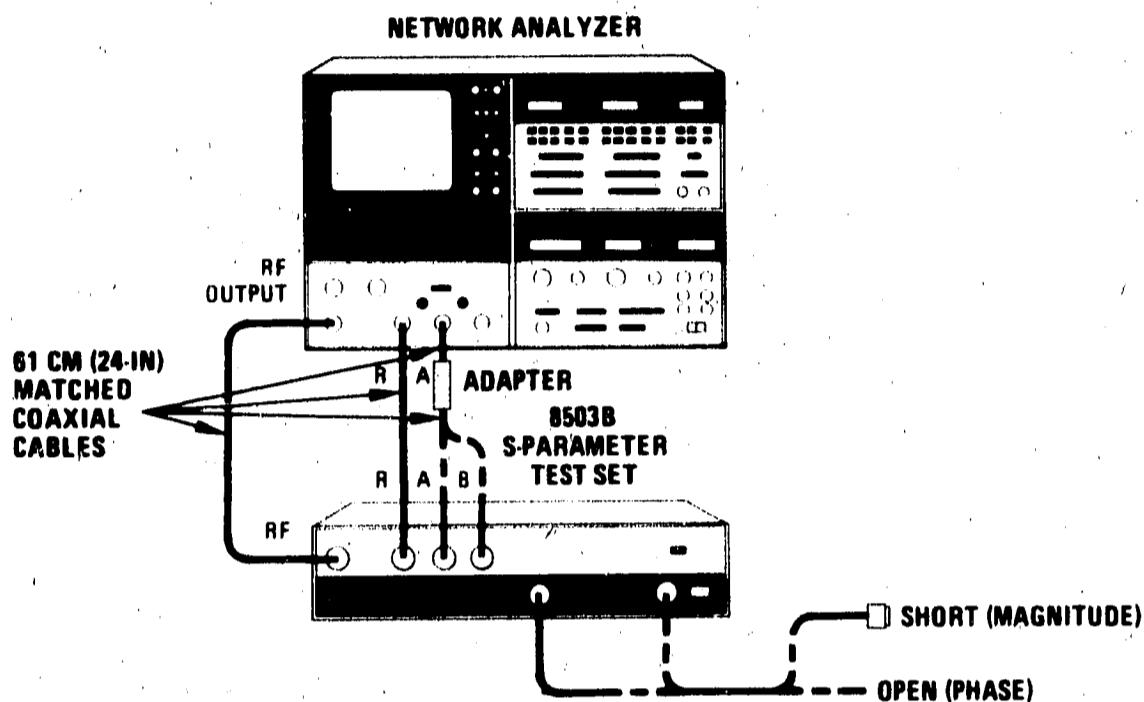

Figure 4-4. Reflection Frequency Response Test Setup (2 of 2)

EQUIPMENT:

Network Analyzer	HP 8505A
3-Way Power Splitter	HP 11850A
50Ω Type N Male Termination	HP 909A Option 012
Matched Type N Male Coaxial Cable Kit	HP 11851A
75Ω Type N Male Short	HP 1250-1530*
Adapter, Type N Female to Type N Female	HP 1250-0777

* Part of HP 85036A 75 Type N Calibration Kit

PROCEDURE:

a. Set 8505A controls as follows:

Source/Converter:

OUTPUT LEVEL dBm	- 10
OUTPUT LEVEL Vernier	0
INPUT LEVEL dBm MAX	- 10

PERFORMANCE TESTS

4-10. REFLECTION FREQUENCY RESPONSE TEST (Cont'd)

Frequency Control

RANGE MHz5 — 1300
MODE	LIN FULL
WIDTH	START/STOP 1
SCAN TIME SEC	1 — .1
VERNIER	Fully clockwise
TRIGGER	AUTO
MARKERS Switch	1
MARKER 1	Mid-range
START FREQUENCY	0 MHz
STOP FREQUENCY	1300 MHz

Signal Processor:

Channel 1:

INPUT	A/R
MODE	MAG
SCALE/DIV5 dB

Channel 2:

INPUT	A/R
MODE	PHASE
SCALE/DIV	90 DEG

Electrical Length:

INPUT	A
MODE	X10

- b. Connect equipment as shown in Figure 4-4, Configuration A.
- c. On 8505A CRT display, depress REF LINE POSN pushbutton. Adjust CH 1 and CH 2 controls until traces are positioned to center of screen. Press REF LINE POSN pushbutton again to return system to normal operation.
- d. On 8505A Signal Processor, set Channel 2 MODE switch to OFF.
- e. To record the magnitude frequency response of the network Analyzer move 8505A Frequency Control MARKER 1 to approximately 650 MHz.
 - (1) On the 8505A Signal Processor, press DISPLAY MKR then ZRO pushbuttons to place marker on reference line and to zero digital readout.
 - (2) Grease pencil the trace on the CRT.
- f. To measure the reflection magnitude frequency response of the 8503B, connect equipment as shown in Figure 4-4, Configuration B, with 8503B port A connected to 8505A INPUT A. Connect short to 8503B PORT 1. Set S-PARAMETER SELECT switch to FORWARD.

PERFORMANCE TESTS

4-10. REFLECTION FREQUENCY RESPONSE TEST (Cont'd)

- g. On 8505A Signal Processor, press Channel 1 REF OFFSET Pushbuttons to center the display around the grease pencil trace.
- h. Measure the maximum difference between the grease pencil trace and the display trace (Figure 4-5). This measured value should be $\leq \pm 2$ dB for the entire 0.5 to 1300 MHz frequency range.

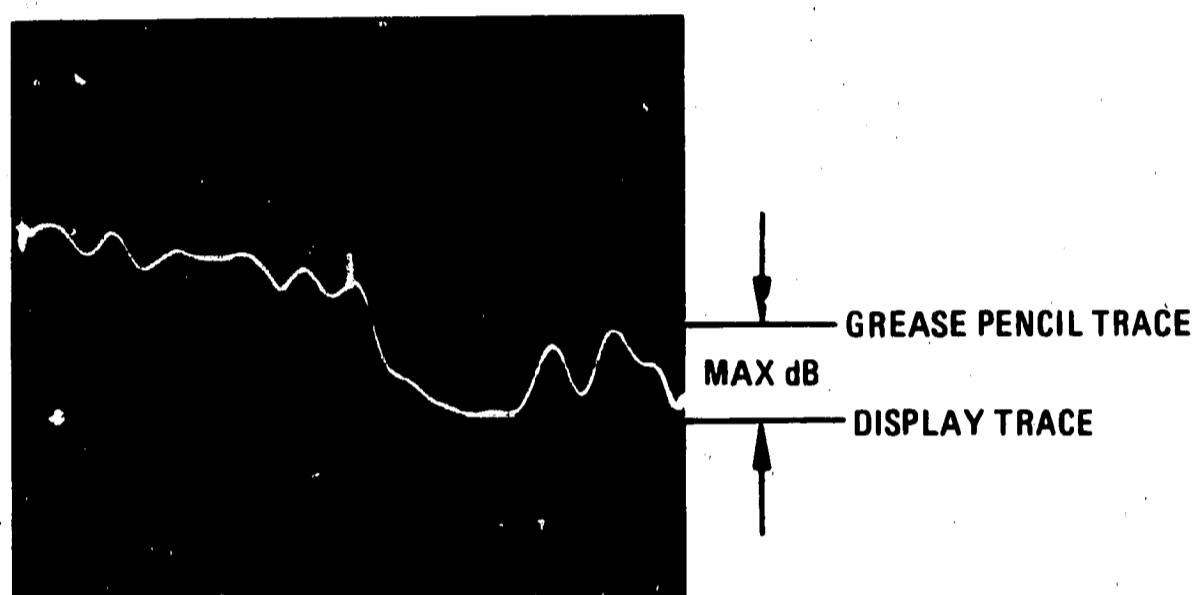

Figure 4-5. Reflection Frequency Response Magnitude

- i. Connect 8503B port B to 8505A INPUT A and connect short to 8503B PORT 2. Set S-PARAMETER SELECT switch to REVERSE.
- j. Repeat steps g and h.
- k. To record the phase frequency response of the Network Analyzer for the full 0.5 to 1300 MHz frequency range, connect equipment as shown in Figure 4-4, Configuration A:
 - (1) Remove CRT grease pencil trace from previous test and remove short from 8503B PORT 2.
 - (2) Set 8505A Signal Processor Channel 1 MODE switch to OFF and Channel 2 MODE switch to PHASE.
 - (3) On the 8505A Signal Processor, press the LENGTH pushbuttons and adjust VERNIER A control to display a horizontal trace on the CRT.
 - (4) Set 8505A Signal Processor Channel 2 SCALE/DIV switch to 5 DEG. Re-adjust length (with LENGTH pushbuttons) and VERNIER A control for a horizontal trace on the CRT.

PERFORMANCE TESTS

4-10. REFLECTION FREQUENCY RESPONSE TEST (Cont'd)

- (5) On the 8505A Signal Processor, press Channel 2 DISPLAY MKR then ZRO pushbuttons to place marker on reference line and to zero digital readout. Readjust LENGTH and VERNIER A control, if necessary, to position average slope of trace parallel to horizontal graticule lines.
 - (6) Grease pencil the trace on the CRT.
- I. To measure the reflection phase frequency response of the 8503B, connect equipment as shown in Figure 4-4, Configuration B, with 8503B port B connected to 8505A INPUT A and 8503B PORT 2 open.
- (1) On 8505A Signal Processor, press the LENGTH Pushbuttons and adjust VERNIER A control to position average slope of trace parallel to horizontal graticule lines.
 - (2) On 8505A Signal Processor, press Channel 2 MKR then ZRO pushbuttons.
 - (3) On 8505A Signal Processor, press Channel 2 REF OFFSET pushbuttons to center the display around the grease pencil trace.
 - (4) Measure the maximum difference between the grease pencil trace and the display trace (Figure 4-6). This measured value should be $\leq \pm 20^\circ$ for the 0.5 to 1300 MHz frequency range.

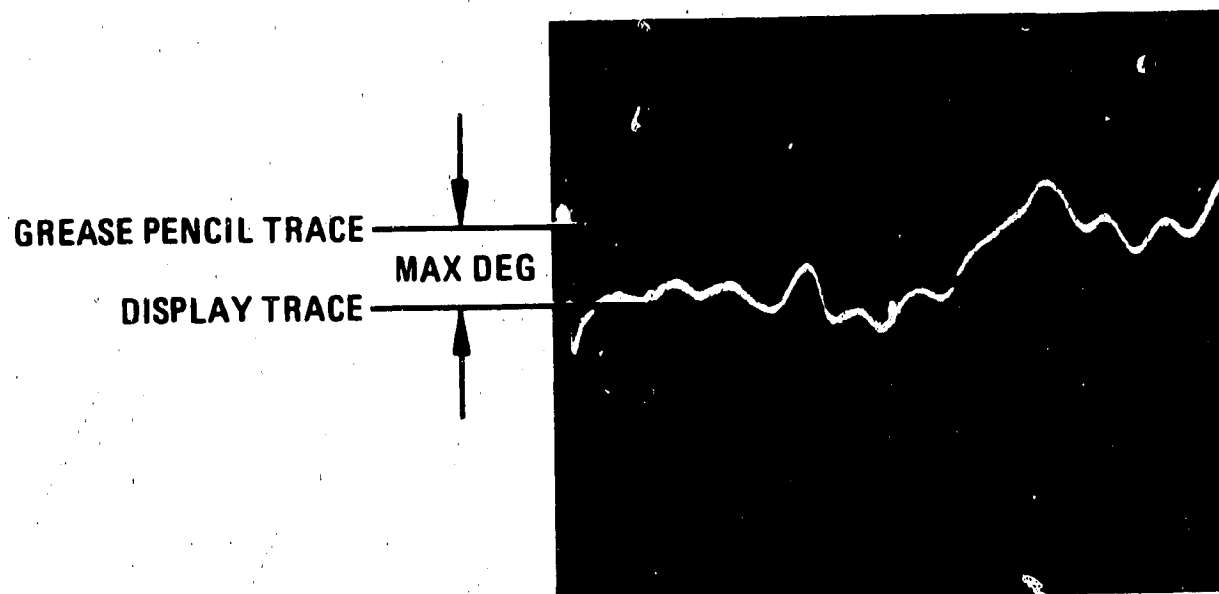

Figure 4-6. Reflection Frequency Response Phase

PERFORMANCE TESTS

4-10. REFLECTION FREQUENCY RESPONSE TEST (Cont'd)

- m. Connect 8503B port A to 8505A INPUT A. Set S-PARAMETER SELECT switch to FORWARD. With 8503B Port 1 open, repeat steps l (1) through l (4).
- n. To record the phase frequency response of the Network Analyzer for the 2 to 1300 MHz frequency range, connect equipment as shown in Figure 4-4, Configuration A:
- (1) Remove CRT grease pencil trace from previous test.
 - (2) On 8505A Frequency Control, set MODE switch to LIN EXPAND.
 - (3) Set 8505A Frequency Control START FREQUENCY to 2 MHz and STOP FREQUENCY to 1300 MHz.
 - (4) Set 8505A Signal Processor Channel 2 SCALE/DIV switch to 90 DEG.
 - (5) Repeat steps k (3) through (6).
- o. To measure the reflection phase frequency response of the 8503B connect equipment as shown in Figure 4-4, Configuration B with 8503B port A connected to 8505A INPUT A and 8503B PORT 1 open. Set S-PARAMETER SELECT switch to FORWARD.
- (1) Repeat steps l (1) through l (3).
 - (2) Measure the maximum difference between the grease pencil trace and the display trace (Figure 4-6). This measured value should be $\leq \pm 15^\circ$ for the 2 to 1300 MHz frequency range.
 - (3) Connect 8503B port B to 8505A INPUT A. Set S-PARAMETER SELECT switch to REVERSE and repeat steps l (1) through l (3).
 - (4) Measure the maximum difference between the grease pencil trace and the display trace. This measured value should be $\leq \pm 15^\circ$ (2 to 1300 MHz).
 - (5) Remove grease pencil trace from CRT.

4-11. TEST PORT OPEN/SHORT RATIO TEST**SPECIFICATION:**

Test Port 1 and 2 Open/Short Ratio:

$\leq \pm 0.9$ dB Mag and $\leq \pm 7.5^\circ$ Phase from 2 to 1300 MHz
 $\leq \pm 1.25$ dB Mag and $\leq \pm 10^\circ$ Phase from 0.5 to 2 MHz

PERFORMANCE TESTS

4-11. TEST PORT OPEN/SHORT RATIO TEST (Cont'd)

DESCRIPTION:

Magnitude open/short ratio and Phase open/short ratio for frequencies above 2 MHz are measured using the reflections generated by a short through a 6-ft. coaxial cable which is connected to the 8503B PORT 1 or PORT 2. Peak-to-peak readings are taken from the CRT trace. The effect of the return loss of the cable used is then accounted for to determine the actual open/short ratio. To compensate for the added line length on the 8503B Test port, a 12-ft. coaxial cable is connected from 8503B port R to 8505A INPUT R. For frequencies below 2 MHz, PORT 1 or PORT 2 is directly shorted, then opened, and this ratio is read directly from the CRT trace.

CONFIGURATION A
(Frequency Range: 2 – 1300 MHz)

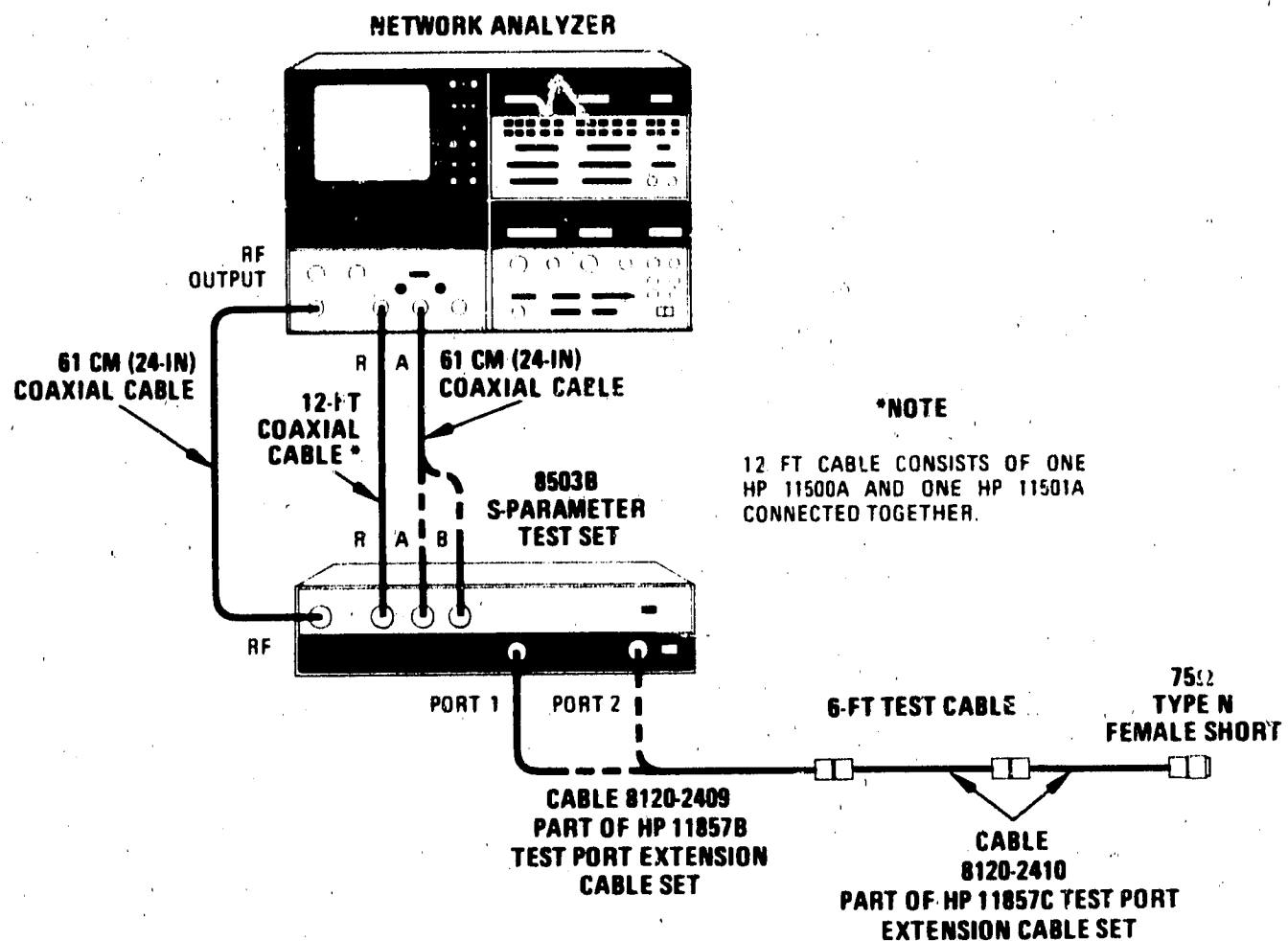

Figure 4-7. Test Port Open/Short Ratio Test (1 of 2)

PERFORMANCE TESTS

4-11. TEST PORT OPEN/SHORT RATIO TEST (Cont'd)

CONFIGURATION B
(Frequency Range: 0.5 – 2 MHz)

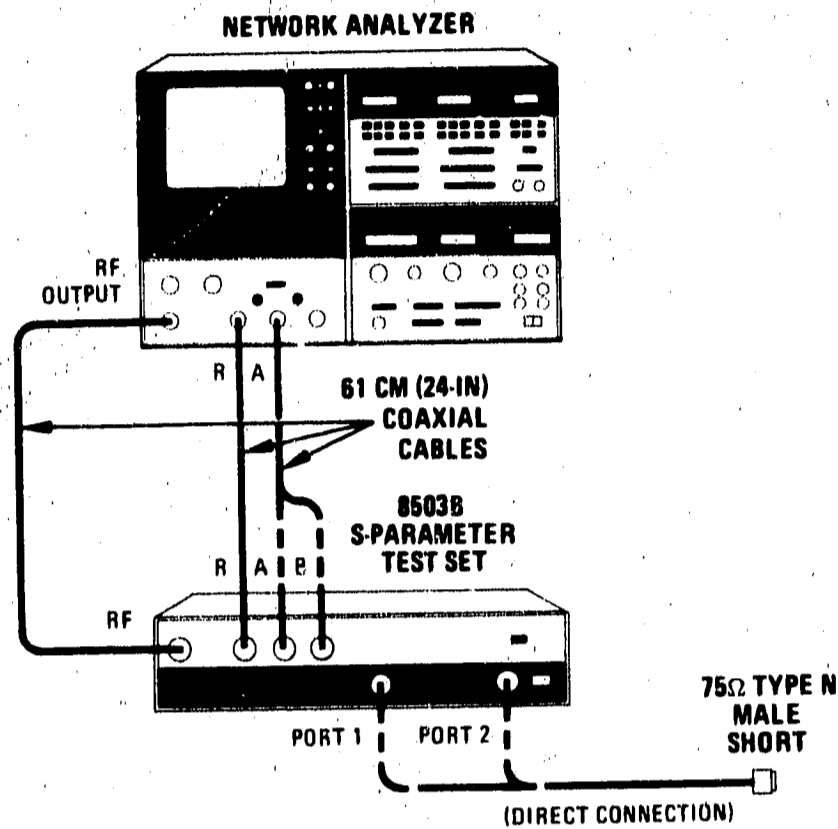

Figure 4-7. Test Port Open/Short Ratio Test (2 of 2)

EQUIPMENT:

- Network Analyzer HP 8505A
- 75Ω Type N Female Short HP 1250-1531*
- 75Ω Type N Male Short HP 1250-1530*
- 2-Ft. Coaxial Cable, Type RF-59 with
75-ohm Type N male connector on one
end and 75-ohm Type N female connector
on other end HP 8120-2409**
- 2-Ft. Coaxial Cable, Type TRF-59 with
75-ohm Type N male connector on one
end and 75-ohm GR-900 connector on
other end (2 required) HP 11857C
- 6-Ft. Coaxial Cable, Type RG-214 (50Ω) with
Type N male connector on each end
(2 required) HP 11500A
- 24-Inch 50-Ohm Coaxial Cable with Type N
male connector on each end (3 matched
cables required) HP 11851A

* Part of HP 11855A 75-ohm Type N Accessory Kit

** Part of 11857B 75-ohm Test Port Extender Cable Set

PERFORMANCE TESTS

4-11. TEST PORT OPEN/SHORT RATIO TEST (Cont'd)

PROCEDURE:

- a. Set 8505A controls as follows:

Source/Converter:

OUTPUT LEVEL dBm -10
 OUTPUT LEVEL Vernier 0
 INPUT LEVEL dBm MAX -10

Frequency Control:

RANGE MHz5 — 1300
 MODE LIN EXPAND
 WIDTH START/STOP 1
 SCAN TIME SEC 1 — .1
 VERNIER Fully clockwise
 TRIGGER AUTO
 START FREQUENCY 1000 MHz
 STOP FREQUENCY 1300 MHz
 MARKER 1 Mid-range

Signal Processor:

Channel 1:

INPUT A/R
 MODE MAG
 SCALE/DIV5 dB

Channel 2:

INPUT A/R
 MODE PHASE
 SCALE/DIV 90° DEG

Electrical Length:

INPUT A
 MODE X10

- b. Connect equipment as shown in Figure 4-7, Configuration A with 8503B port A connected to 8505A INPUT A, and 6-ft. coaxial cable (75-ohm) and short connected to PORT 1. Set S-PARAMETER SELECT switch to FORWARD.
- c. On 8505A CRT display, depress REF LINE POSN pushbutton. Adjust CH 1 and CH 2 controls until traces are positioned to center of screen. Press REF LINE POSN pushbutton again to return system to normal operation.
- d. On 8505A Signal Processor, set Channel 2 MODE switch to OFF.
- e. To measure the test port open/short magnitude ratio, move 8505A Frequency Control MARKER 1 to upper peak where maximum separation between upper and lower peaks occur.

PERFORMANCE TESTS

4-11. TEST PORT OPEN/SHORT RATIO TEST (Cont'd)

- (1) On the 8505A Signal Processor Channel 1, press DISPLAY MKR then ZRO pushbuttons to place marker on reference line and to zero digital readout.
- (2) Set MARKER 1 to corresponding lower peak (see Figure 4-8) and record peak-to-peak variation indicated on Channel 1 MKR digital readout.

PORT 1 Magnitude: 2 to 1300 MHz = _____ dB

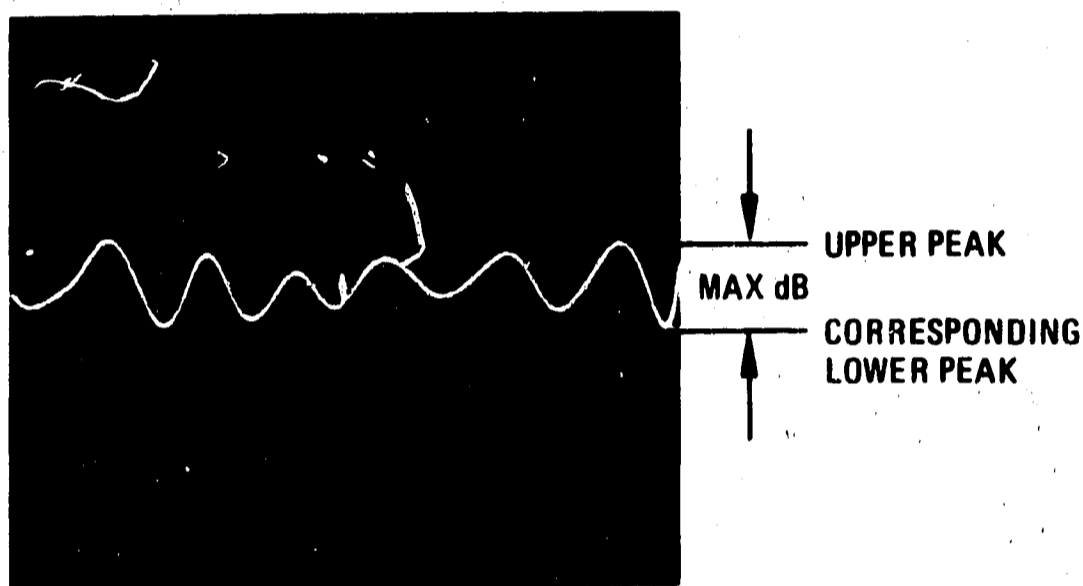

Figure 4-8. Test Port Open/Short Ratio Magnitude, >2 MHz

NOTE

If peak-to-peak measurement is made in an area where there is some slope, a corrected reading can be obtained by connecting two adjacent upper peaks with a dotted line. Extend a vertical line up from the lower peak until it intersects the dotted line. This constructed vertical line is the averaged or corrected peak-to-peak measurement to be used (Figure 4-9). Avoid making peak-to-peak measurements at extreme slope changes.

PERFORMANCE TESTS

4-11. TEST PORT OPEN/SHORT RATIO TEST (Cont'd)

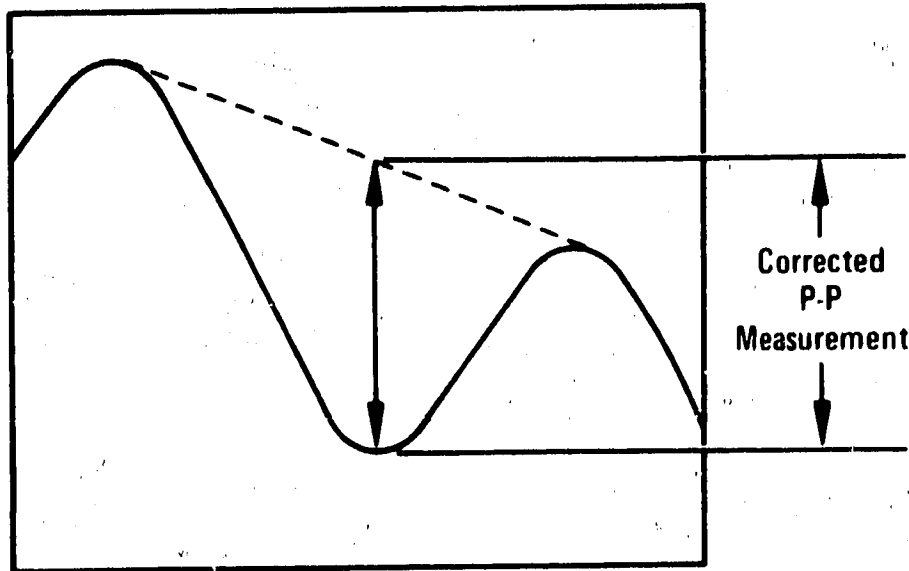

Figure 4-9. Slope Peak-to-Peak Measurement

f. Connect 8503B port B to 8505A INPUT A and connect 6-ft. coaxial cable (75-ohm) and short to PORT 2. Set S-PARAMETER SELECT switch to REVERSE.

g. Repeat step e and record the results:

PORT 2 Magnitude: 2 to 1300 MHz = _____ dB

h. Calculate the actual maximum open/short magnitude ratio by dividing the measured values (recorded in steps e and go or step m) by the reflection coefficient of the 6-foot test cable (Table 4-1, 1000 MHz Column) as shown below:

$$\frac{\text{MEASURED VALUE dB}}{\text{REFLECTION COEFFICIENT OF TEST CABLE}} = \text{ACTUAL OPEN/SHORT RATIO MAGNITUDE}$$

The actual open/short ratio magnitude for 1000 to 1300 MHz should be ≤ 1.8 dB ($\leq \pm 0.9$ dB) for both 8503B test ports (PORT 1 and PORT 2).

PERFORMANCE TESTS

4-11. TEST PORT OPEN/SHORT RATIO TEST (Cont'd)

Table 4-1. Reflection Coefficient (ρ) of Coaxial Cable Used for 6-Ft. "Test" Cable

Cable Type	500 MHz ρ for 12-Ft. (out & back)	1000 MHz ρ for 12-Ft. (out & back)
TRF-59	0.91	0.88

i. To measure the test port open/short phase ratio:

- (1) Set 8505A Signal Processor Channel 1 MODE switch to OFF and Channel 2 MODE switch to PHASE.
- (2) On 8505A Signal Processor channel 2 press DISPLAY MKR then ZRO pushbuttons.
- (3) On 8505A Signal Processor Electrical Length, press LENGTH pushbuttons and adjust VERNIER A control to display a horizontal trace on the CRT. Set Channel 2 SCALE/DIV switch to 5 DEG. Press DISPLAY MKR then ZRO pushbuttons and readjust LENGTH and VERNIER A control to position average slope of trace parallel to horizontal graticule lines.
- (4) On 8505A Frequency Control, set MARKER 1 to upper peak where maximum separation between upper and lower peaks occur.
- (5) On 8505A Signal Processor Channel 1, press DISPLAY MKR then ZRO pushbuttons to place marker on reference line and to zero digital readout.
- (6) Set MARKER 1 to corresponding lower peak (see Figure 4-10) and record peak-to-peak variation indicated on Channel 1 MKR digital readout. (See NOTE preceding Figure 4-9).

PORT 2 Phase: 2 to 1300 MHz = _____ DEG

j. Connect 8503B port A to 8505A INPUT A and connect 6-ft. coaxial cable (75-ohm) and short to PORT 1. Set S-PARAMETER SELECT switch to FORWARD. Adjust 8505A Electrical Length controls, if necessary, to position average slope of trace parallel to horizontal graticule lines.

k. Repeat steps i (4) through i (6) and record results:

PORT 1 Phase: 2 to 1300 MHz = _____ DEG

PERFORMANCE TESTS

4-11. TEST PORT OPEN/SHORT RATIO TEST (Cont'd)

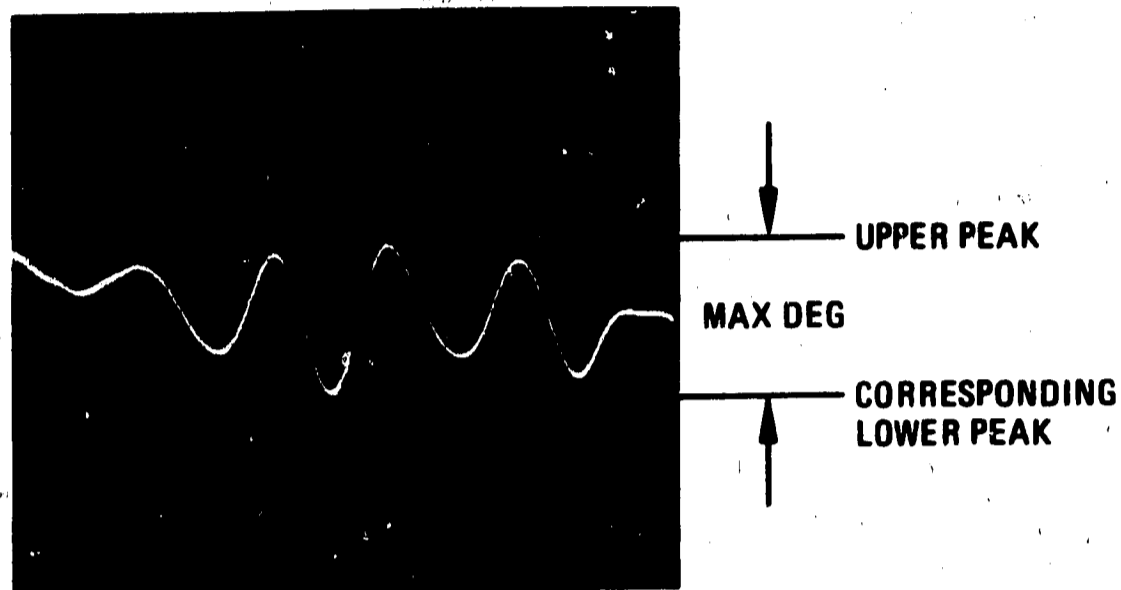

Figure 4-10. Test Port Open/Short Ratio Phase, >2 MHz

1. Calculate the actual maximum open/short ratio phase by dividing the measured values (recorded in steps i and k or step n) by the reflection coefficient of the 6-foot test cable (Table 4-1, 1000 MHz Column), or:

$$\frac{\text{MEASURED VALUE DEG}}{\text{REFLECTION COEFFICIENT OF TEST CABLE}} = \text{ACTUAL OPEN/SHORT PHASE RATIO}$$

The actual open/short phase ratio for 2 to 1300 MHz should be $\leq 15^\circ$ ($\leq \pm 7.5^\circ$) for both 8503A test ports (PORT 1 and PORT 2).

PERFORMANCE TESTS

4-11. TEST PORT OPEN/SHORT RATIO TEST (Cont'd)

- m. To measure magnitude and phase open/short ratios below 2 MHz, connect equipment as shown in Figure 4-7, Configuration B, with 8503B port A connected to 8505A INPUT A and both 8503B test ports open.
- (1) Set 8505A Frequency Control RANGE MHz switch to .5 — 13.
 - (2) Set 8505A Frequency Control START FREQUENCY to 00.50 and STOP FREQUENCY to 02.00.
 - (3) Set 8505A Signal Processor Channel 1 MODE switch to MAG and Channel 2 MODE switch to OFF. Set 8503B S-PARAMETER SELECT switch to FORWARD.
 - (4) On 8505A Signal Processor Channel 1, press MKR then ZRO pushbuttons to bring trace to on-screen position.
 - (5) On 8505A Frequency Control, set MARKER 1 to beginning of sweep on CRT.
 - (6) On 8505A Signal Processor Channel 1, press MKR then ZRO pushbuttons to place marker on reference line and to zero digital readout.
- n. To measure the test port open/short magnitude ratio between 0.5 to 2 MHz:
- (1) Connect 75-ohm short directly to PORT 1.
 - (2) 8503B Signal Processor Channel 1 MKR digital display should indicate ≤ 2.50 dB ($\leq \pm 1.25$ dB).
 - (3) Connect 8503B port B to 8505A INPUT A and set S-PARAMETER SELECT switch to REVERSE. Press Channel 1 DISPLAY MKR then ZRO.
 - (4) Connect 75-ohm short directly to PORT 2. 8505A Signal Processor Channel 1 MKR digital display should indicate 2.50 dB (± 1.25 dB).
- o. To measure the test port open/short phase ratio between 0.5 and 2 MHz:
- (1) Remove short from PORT 2.

PERFORMANCE TESTS

4-11. TEST PORT OPEN/SHORT RATIO TEST (Cont'd)

- (2) Set 8505A Signal Processor Channel 1 MODE switch to OFF and Channel 2 MODE switch to PHASE.
- (3) On 8505A Signal Processor, press LENGTH Pushbuttons and adjust VERNIER A control to display a horizontal trace on the CRT. If necessary, change 8505A Signal processor Channel 2 SCALE/DIV switch to a lower sensitivity to position trace to a horizontal position. Return SCALE/DIV switch to 5 DEG setting before going on with test.
- (4) On 8505A Signal Processor Channel 2, press DISPLAY MKR then ZRO then REF pushbuttons.
- (5) On 8505A Signal Processor Channel 2, press REF OFFSET Pushbuttons to indicate +180 DEG on digital display.
- (6) On 8505A Signal Processor Channel 2, press DISPLAY MKR pushbutton.
- (7) Connect 75-ohm short directly to PORT 2.
- (8) Digital display should indicate $\leq 20^\circ$ ($\leq \pm 10^\circ$).
- (9) Connect 8503B port A to 8505A INPUT A and remove short from PORT 2. Set S-PARAMETER SELECT switch to FORWARD.
- (10) On 8505A Signal Processor Channel 2, press DISPLAY MKR then ZRO to zero digital readout.
- (11) Repeat steps o (3) through o (6).
- (12) Connect 75-ohm short directly to PORT 1.
- (13) Digital display should indicate $\leq 20^\circ$ ($\leq \pm 10^\circ$).

4-12. TEST PORT RETURN LOSS TEST
SPECIFICATION:

Test Port 1 and 2 Return Loss: ≥ 24 dB (≤ 1.135 SWR) from 2 to 1300 MHz
 ≥ 18 dB (≤ 1.29 SWR) from 0.5 to 2 MHz

DESCRIPTION:

Perform the Directivity (Incoming Inspection Test, Figure 2-4) and the Test Port Open/Short Ratio Test (Paragraph 4-11). These two tests confirm that PORT 1 and PORT 2 return loss of the 8503B is within specification. If a more direct and accurate test is required for test port return loss, refer to the 85030A Accuracy Enhancement Program (AIM) procedure for the method of making an error-corrected return loss measurement. An 8542B Automatic Network Analyzer may also be used to make this measurement between 100 and 1300 MHz.

PERFORMANCE TESTS

4-13. PORT RETURN LOSS TESTS

SPECIFICATIONS:

Reference and Return Ports (R, A, B):

- ≥ 20 dB Return Loss (≤ 1.22 SWR) from 0.5 to 2 MHz
- ≥ 23 dB Return Loss (≤ 1.15 SWR) from 2 to 1000 MHz
- ≥ 20 dB Return Loss (≤ 1.22 SWR) from 100 to 1300 MHz

RF Input Port:

- ≥ 20 dB Return Loss (≤ 1.22 SWR) from 0.5 to 1300 MHz

DESCRIPTION:

The system is calibrated by shorting or opening the main line TEST Port of the Directional Coupler to establish a 0 dB reference line on the CRT display. Ports R, A, B and RF of the 8503B are in turn connected in place of the short to the Dual Directional Coupler or Directional Bridge with all other ports terminated in their characteristic impedances. The return loss is measured directly with the 8505A MARKER digital display and the CRT trace. When using this method to measure return loss, ambiguity due to "imperfect" directivity of the directional device is introduced. The ambiguity of the measurement may be as great as ± 2 dB. If a more direct and accurate test is required for port return loss, refer to the 85030A Accuracy Enhancement Program (AIM) procedure for the method of making an error-correct Return Loss measurement.

CONFIGURATION A
(Frequency Range: 100 — 1300 MHz)

NOTE

THE TEST SETUP SHOWN IS FOR PORT R RETURN LOSS MEASUREMENTS. FOR PORT A, PORT B, AND RF INPUT PORT MEASUREMENTS, THE SETUPS (CONFIGURATIONS A AND B) ARE IDENTICAL EXCEPT THAT THE PORT TO BE MEASURED IS DIRECTLY CONNECTED TO THE DUAL DIRECTIONAL COUPLER (CONFIGURATION A) OF THE DIRECTIONAL BRIDGE (CONFIGURATION B) WITH ALL OTHER PORTS TERMINATED IN THEIR CHARACTERISTIC IMPEDANCES.

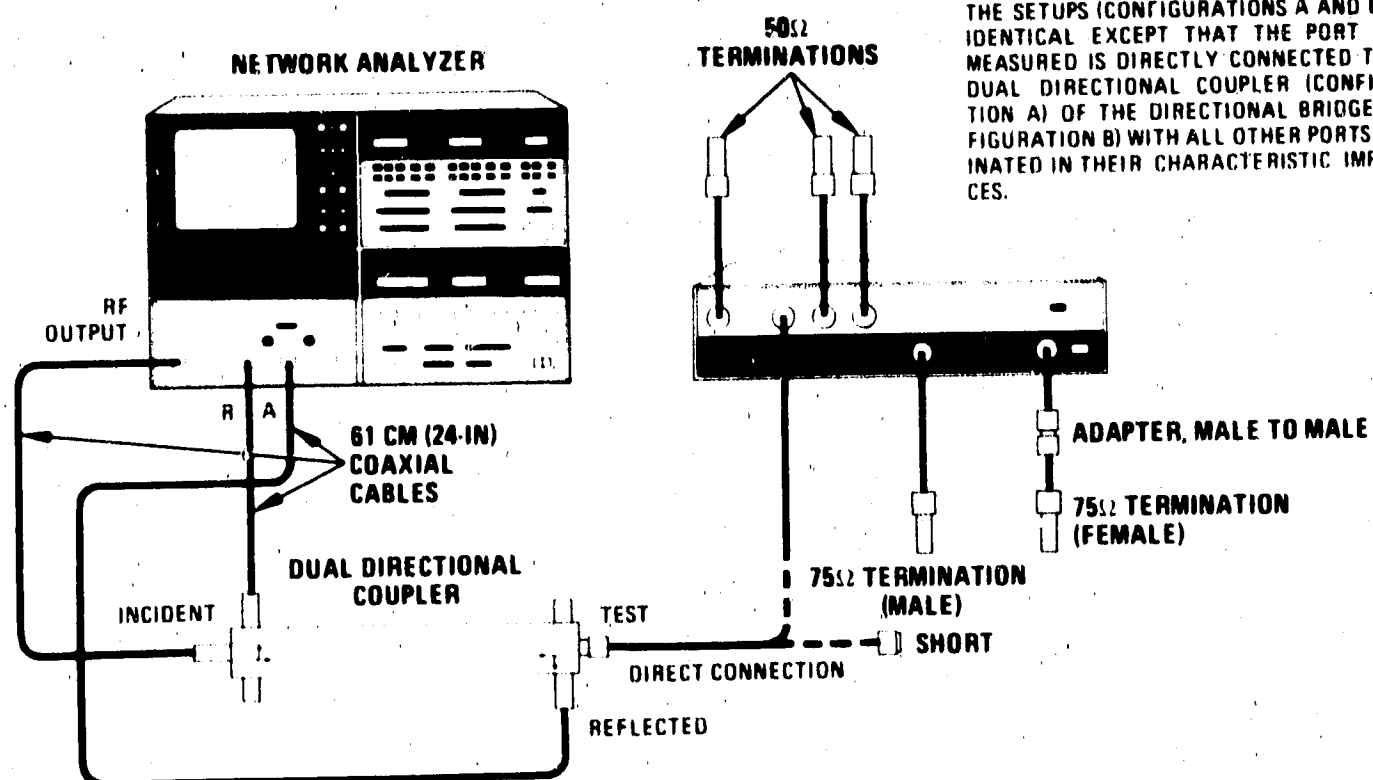

Figure 4-11. Port Return Loss Test Setup (1 of 2)

PERFORMANCE TESTS

4-13. PORT RETURN LOSS TESTS (Cont'd)

CONFIGURATION B
(Frequency Range: 0.5 – 100 MHz)

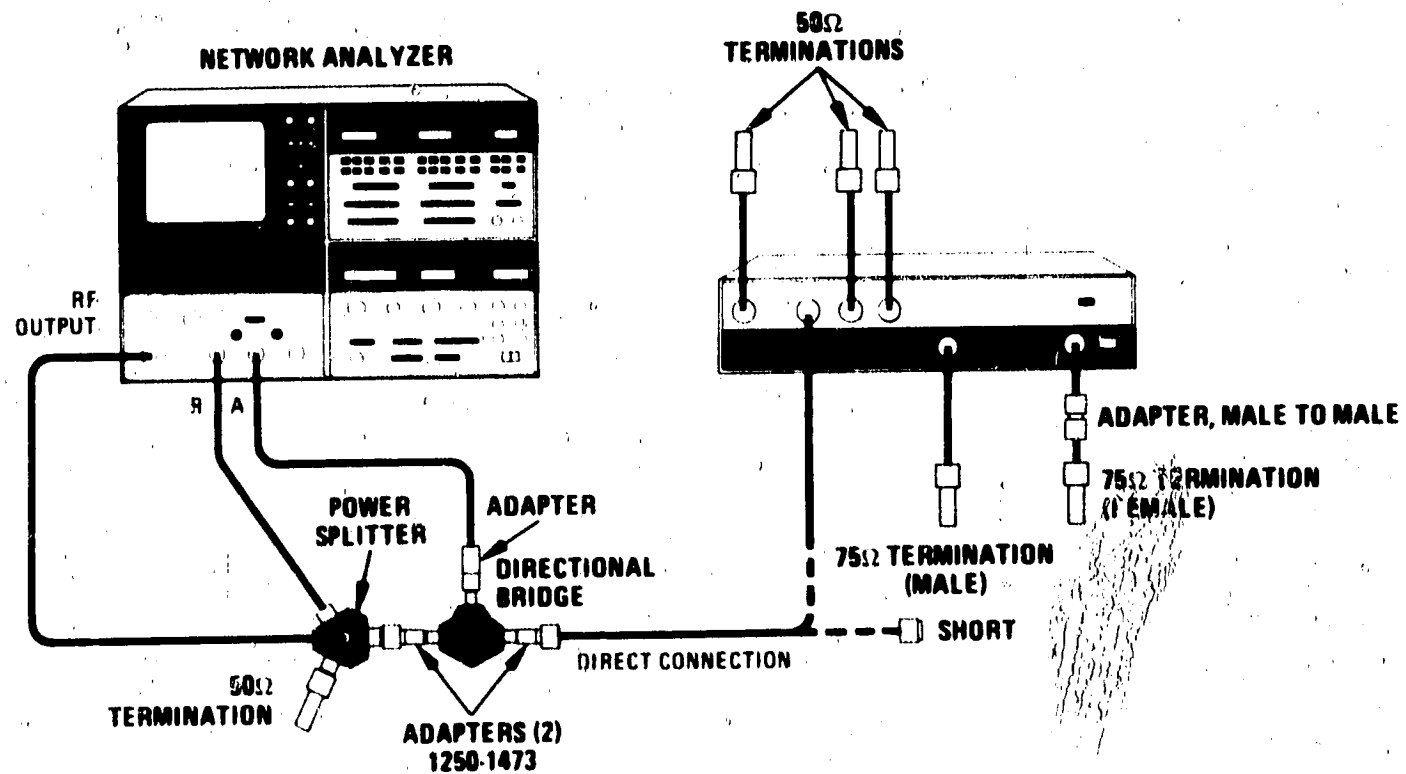

Figure 4-11. Port Return Loss Test Setup (2 of 2)

EQUIPMENT:

Network Analyzer	HP 8505A
Dual Directional Coupler	HP 778D
Directional Bridge	HP 8721A*
3-Way Power Splitter	HP 11850A
Short, 50Ω Type N Female	HP 11511A
Termination, 50Ω Type N Male (4 required)	HP 909A Option 012
Termination, 75Ω Type N Male	HP 1250-1540**
Termination, 75Ω Type N Female	HP 1250-1541**
Adapter, 75Ω Type N Male to Type N Male	HP 1250-1528**
Adapter, 50Ω Type N Male to BNC Male (2 required)	HP 1250-1473***
Adapter, 50Ω Type N Female to BNC Male	HP 1250-1477***

*Part of HP 11652A Transmission/Reflection Kit
 **Part of HP 85036A 75Ω Type N Calibration Kit
 ***Part of HP 11854A 50Ω BNC Accessory Kit

PERFORMANCE TESTS

4-13. PORT RETURN LOSS TESTS (Cont'd)

PROCEDURE:

- a. Set 8505A controls as follows:

Source/Converter:

OUTPUT LEVEL dBm	-10
OUTPUT LEVEL Vernier	0
INPUT LEVEL dBm MAX	-10

Frequency Control:

RANGE5 — 1300
MODE	LIN EXPAND
WIDTH	START/STOP 1
SCAN TIME SEC	1 — .1
VERNIER	Fully clockwise
TRIGGER	AUTO
MARKERS Switch	1
START FREQUENCY	100 MHz
STOP FREQUENCY	1300 MHz
MARKER 1	1000 MHz

Signal Processor:

Channel 1:	
INPUT	A/R
MODE	MAG
SCALE/DIV	20 dB

Channel 2:	
MODE	OFF

Electrical Length:	
MODE	OFF

- b. Connect equipment as shown in Figure 4-11, Configuration A, with no connection to mainline TEST Port of Directional Coupler.
- c. On 8505A display, depress REF LINE POSN Pushbutton. Adjust CH 1 control until trace is positioned to center of screen. Press REF LINE POSN pushbutton again to return system to normal operation.
- d. Set 8505A Frequency Control MARKERS switch to 2.
- e. Place 8505A Frequency Control MARKER 2 on center graticule line.
- f. To calibrate the system for return loss measurement, attach short directly to Dual Directional Coupler mainline TEST Port. On 8505A Signal Processor Channel 1, press DISPLAY MKR then ZRO pushbuttons to place MARKER 2 on reference line and to zero digital readout.

PERFORMANCE TESTS

4-13. PORT RETURN LOSS TESTS (Cont'd)

g. To measure return loss for the frequency range 1000 to 1300 MHz:

- (1) Remove short and connect dual Directional Coupler directly to 8503B port R with all other 8503B ports terminated in their characteristic impedences.
- (2) Move 8505A Frequency Control MARKER 2 to worst-case return loss between 100 and 1300 MHz as indicated on CRT (the point closest to calibration line to the right of MARKER 1 as shown in Figure 4-12).

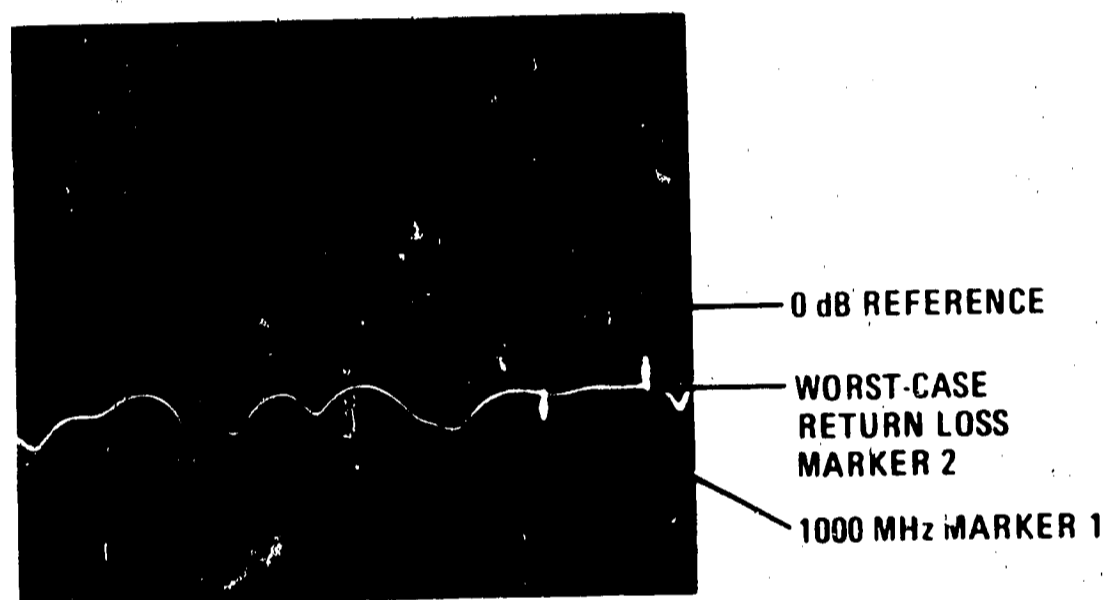

Figure 4-12. Port Return Loss (1000 - 1300 MHz)

- (3) Read worst-case return loss from 8505A Signal Processor Channel 1 digital display. The indication should be 20 dB below the zero dB reference level for the frequency range 1000 to 1300 MHz.
- h. To measure return loss for the frequency range 100 to 1000 MHz:
- (1) Move 8505A Frequency Control MARKER 2 control to worst-case return loss between 100 and 1000 MHz as indicated on CRT (the point closest to calibration line to left of MARKER 1 as shown in Figure 4-13).
 - (2) Read worst-case return loss from 8505A Signal Processor Channel 1 digital display. The indication should be ≥ 23 dB below the zero dB reference level for the frequency range 100 to 1000 MHz.

PERFORMANCE TESTS

4-13. PORT RETURN LOSS TESTS (Cont'd)

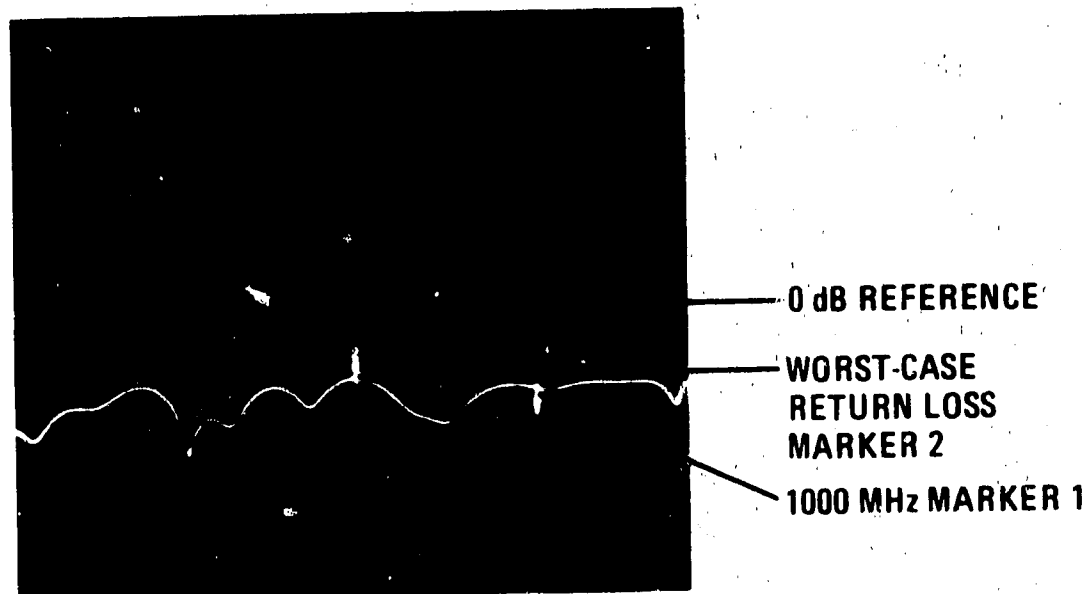

Figure 4-13. Port Return Loss (100 - 1000 MHz)

- i. For port A and B return loss measurements from 100 MHz to 1300 MHz, repeat steps a through h except directly connect the port being measured to the dual Directional Coupler with all other 8503B ports terminated in their characteristic impedances.
- j. To determine return loss for the frequency range 2 to 100 MHz, connect equipment as shown in Figure 4-11, Configuration B, with LOAD port on Directional Bridge shorted. Set 8505A Frequency Control RANGE MHz switch to .5 - 130. Set START FREQUENCY to 2 MHz and STOP FREQUENCY to 100 MHz.
- k. To calibrate system for return loss measurement:
 - (1) Set 8505A Frequency Control MARKERS switch to 1 and set MARKER 1 to center graticule line.
 - (2) On 8505A Signal Processor Channel, press DISPLAY MKR then ZRO pushbuttons to place MARKER 1 on reference line and to zero digital readout.
- l. To measure the return loss for 2 to 100 MHz:
 - (1) Remove short and connect 8503B port R to Directional Bridge LOAD port with all other 8503B ports terminated.
 - (2) Move 8505A Frequency Control MARKER 1 to worst-case return loss between 2 and 100 MHz as indicated on CRT (the point closest to calibration line as shown in Figure 4-14).

PERFORMANCE TESTS

4-13. PORT RETURN LOSS TESTS (Cont'd)

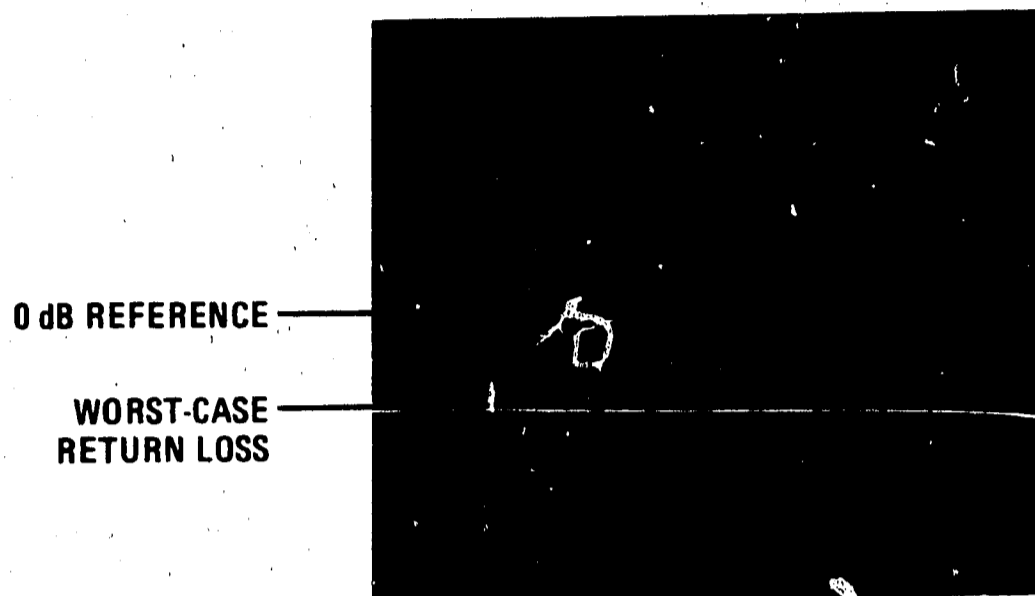

Figure 4-14. Port Return Loss (2 - 100 MHz)

- (3) Read worst-case return loss from 8505A Signal Processor Channel 1 digital display. The indication should be 23 dB below the zero dB reference level for the frequency range 2 to 100 MHz.
- m. For port A and Port B return loss measurements from 2 MHz to 100 MHz, repeat step 1 except connect the port being measured to Directional Bridge LOAD port with all other 8503B ports terminated in their characteristic impedances.
 - n. To determine return loss for the frequency range 0.5 to 2 MHz:
 - (1) Set 8505A Frequency Control RANGE MHz switch to .5 to 13. Set START FREQUENCY to 0.5 MHz and STOP FREQUENCY to 2 MHz. Connect short to Directional Bridge LOAD port.
 - (2) Repeat steps k and l except that the indication should be ≥ 20 dB below the zero dB reference level for the frequency range 0.5 to 2 MHz (Figure 4-15).
 - o. For port A and port B return loss measurements, repeat step 1, except connect the port being measured to the Directional Bridge with all other 8503B ports terminated in their characteristic impedances.
 - p. For RF port return loss measurement, repeat steps a through f.
 - q. To measure return loss for the frequency range 100 to 1300 MHz:
 - (1) Remove short and connect Dual Directional Coupler directly to 8503B RF port.

PERFORMANCE TESTS

4-13. PORT RETURN LOSS TESTS (Cont'd)

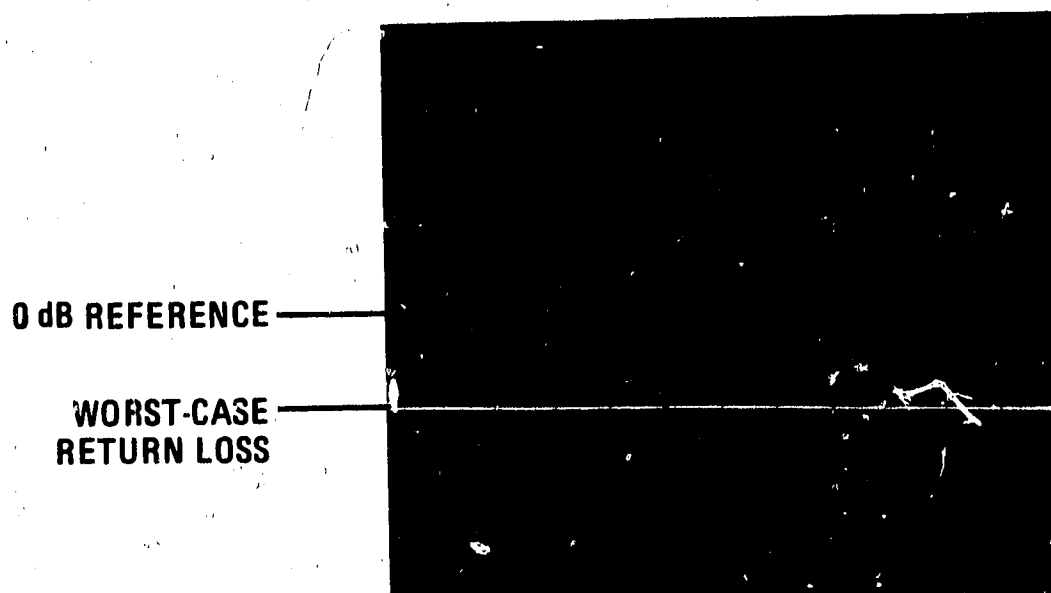

Figure 4-15. Port Return Loss (0.5 - 2 MHz)

- (2) Move 8505A Frequency Control MARKER 2 to worst case return loss indicated on CRT (point closest to calibration line).
 - (3) Read worst-case return loss from 8505A Signal Processor Channel 1 digital display. The indication should be ≥ 20 dB below the zero dB reference level for frequency range 100 to 1300 MHz.
- r. To calibrate the system for return loss measurement from 0.5 to 100 MHz:
- (1) Connect equipment as shown in Figure 4-11, Configuration B, with LOAD Port on Directional Bridge shorted.
 - (2) On 8505A Frequency Control, set RANGE MHz switch to .5 - 130. Set START FREQUENCY to 0.5 MHz and STOP FREQUENCY to 100 MHz.
 - (3) Set 8505A Frequency Control MARKERS switch to 1 and set MARKER 1 to center graticule line.
 - (4) On 8505A Signal Processor, press Channel 1 DISPLAY MKR then ZRO pushbuttons to place MARKER 1 on reference line and to zero digital readout.
- s. To measure return loss for 0.5 to 100 MHz:
- (1) Remove short and connect 8503B RF port to Directional Bridge LOAD Port with all other 8503B ports terminated.

PERFORMANCE TESTS

4-13. PORT RETURN LOSS TESTS (Cont'd)

- (2) Move 8505A Frequency Control MARKER 1 to worst-case return loss as indicated on CRT (point closest to calibration line).
- (3) Read worst-case return loss from 8505A Signal Processor Channel 1 digital display. The indication should be ≥ 20 dB below zero dB reference level for frequency range 0.5 to 100 MHz.

Table 4-2. Model 8503B Performance Test Record (1 of 3)

Hewlett-Packard Model 8503B S-Parameter Test Set		Test Performed By: _____		
Serial Number: _____		Date: _____		
Para. No.	Description	Lower Limit	Measured Value	Upper Limit
4-8.	DIRECTIVITY TEST			
	PORT 1 PORT 2	40 dB 40 dB	_____ _____	
4-9.	TRANSMISSION FREQUENCY RESPONSE TEST			
	<i>Magnitude:</i>			
	h. FORWARD (S_{21})		_____	±1 dB
	i. REVERSE (S_{12})		_____	±1 dB
	<i>Phase:</i>			
	p. REVERSE (S_{12})		_____	±12°
q. FORWARD (S_{21})		_____	±12°	
4-10.	REFLECTION FREQUENCY RESPONSE TEST			
	<i>Magnitude:</i>			
	h. FORWARD (S_{11})		_____	±2 dB
	j. REVERSE (S_{22})		_____	±2 dB
	<i>Phase; 0.5 to 1300 MHz:</i>			
	l(4). REVERSE (S_{22})		_____	±20°
	m. FORWARD (S_{11})		_____	±20°
	<i>Phase; 2 to 1300 MHz:</i>			
o(2). FORWARD (S_{11})		_____	±15°	
o(4). REVERSE (S_{22})		_____	±15°	
4-11.	TEST PORT OPEN/SHORT RATIO TEST			
	<i>Magnitude; 2 to 1300 MHz:</i>			
	h. PORT 1		_____	1.8 dB (±0.9 dB)
	h. PORT 2		_____	1.8 dB (±0.9 dB)
	<i>Phase; 2 to 1300 MHz:</i>			
	l. PORT 1		_____	15° (±7.5°)
l. PORT 2		_____	15° (±7.5°)	

Table 4-2. Model 8503B Performance Test Record (2 of 3)

Para. No.	Description	Lower Limit	Measured Value	Upper Limit
4-11.	<p>TEST PORT OPEN/SHORT RATIO TEST (Cont'd)</p> <p><i>Magnitude; 0.5 to 2 MHz:</i></p> <p>n (2). PORT 1</p> <p>n (4). PORT 2</p> <p><i>Phase; 0.5 to 2 MHz:</i></p> <p>o (8). PORT 2</p> <p>o (13). PORT 1</p>		<p>_____</p> <p>_____</p> <p>_____</p> <p>_____</p>	<p>2.5 dB (±1.25 dB)</p> <p>2.5 dB (±1.25 dB)</p> <p>20° (±10°)</p> <p>20° (±10°)</p>
4-12.	<p>TEST PORT RETURN LOSS TEST</p> <p><i>2 to 1300 MHz:</i></p> <p>PORT 1</p> <p>PORT 2</p> <p><i>0.5 to 2 MHz:</i></p> <p>PORT 1</p> <p>PORT 2</p>	<p>24 dB</p> <p>24 dB</p> <p>18.0 dB</p> <p>18.0 dB</p>	<p>_____</p> <p>_____</p> <p>_____</p> <p>_____</p>	
4-13.	<p>PORT RETURN LOSS TESTS</p> <p><i>1000 to 1300 MHz:</i></p> <p>g (3). Port R</p> <p>i. Port A</p> <p>i. Port B</p>	<p>20 dB</p> <p>20 dB</p> <p>20 dB</p>	<p>_____</p> <p>_____</p> <p>_____</p>	

Table 4-2. Model 8503B Performance Test Record (3 of 3)

Para. No.	Description	Lower Limit	Measured Value	Upper Limit
4-13:	<p>PORT RETURN LOSS TESTS (Cont'd)</p> <p><i>100 to 1000 MHz:</i></p> <p>h (2). Port R i. Port A i. Port B</p> <p><i>2 to 100 MHz:</i></p> <p>l (3). Port R m. Port A m. Port B</p> <p><i>0.5 to 2 MHz:</i></p> <p>n (2). Port R o. Port A o. Port B</p> <p><i>RF Input Port:</i></p> <p>q (3). 100 to 1300 MHz s (3). 0.5 to 100 MHz</p>	<p>23 dB 23 dB 23 dB</p> <p>23 dB 23 dB 23 dB</p> <p>20 dB 20 dB 20 dB</p> <p>20 dB 20 dB</p>	<p>_____</p> <p>_____</p> <p>_____</p> <p>_____</p> <p>_____</p> <p>_____</p> <p>_____</p> <p>_____</p> <p>_____</p> <p>_____</p>	

ADJUSTMENTS

SECTION V ADJUSTMENTS

5-1. INTRODUCTION

5-2. The 8503B S-Parameter Test Set has no adjustment controls.

PARTS LIST

SECTION VI REPLACEABLE PARTS

6-1. INTRODUCTION

6-2. This section contains information for ordering parts. Table 6-1 lists abbreviations used in the parts list, schematics, and throughout the manual. Table 6-2 lists all replaceable parts in reference designator order. Table 6-3 contains names and addresses that correspond to the manufacturer's code numbers.

6-3. ABBREVIATIONS

6-4. In Table 6-1, Abbreviations, two forms of the abbreviation are sometimes given. One uses all capital letters, and one partial or no capitals. This is because the abbreviations in the parts list are always all capitals. In the schematics and other parts of the manual, however, other abbreviation forms are used with both lower case and upper case letters.

6-5. REPLACEABLE PARTS LIST

6-6. Table 6-2, the list of replaceable parts, is organized as follows:

- a. Electrical assemblies and their components in alpha-numerical order by reference designation.
- b. Chassis-mounted parts in alpha-numeric order by reference designation.
- c. Miscellaneous parts.

- d. Illustrated parts breakdown, if appropriate.

The information given for each part consists of the following:

- a. The Hewlett-Packard part number
- b. The total quantity (Qty) in the instrument.
- c. The description of the part.
- d. The typical manufacturer of the part in a five-digit code.
- e. Manufacturer code number for the part.

The total quantity for each part is given only once — at the first appearance of the part number in the list.

6-7. ORDERING INFORMATION

6-8. To order a part listed in the replaceable parts table, quote the Hewlett-Packard part number, indicate quantity required, and address the order to the nearest Hewlett-Packard office.

6-9. To order a part that is not listed in the replaceable parts table, include the instrument model number, instrument serial number, the description and function of the part, and the number of parts required. Address the order to the nearest Hewlett-Packard office.

Table 6-2. Reference Designations and Abbreviations

REFERENCE DESIGNATIONS

A assembly	E miscellaneous electrical part	P electrical connector (movable portion); plug	U integrated circuit; microcircuit
AT attenuator; isolator; termination	F fuse	Q transistor: SCR; triode thyristor	V electron tube
B fan; motor	FL filter	R resistor	VR voltage regulator; breakdown diode
BT battery	H hardware	RT thermistor	W cable; transmission path; wire
C capacitor	HY circulator	S switch	X socket
CP coupler	J electrical connector (stationary portion); jack	T transformer	Y crystal unit (piezo-electric or quartz)
CR diode; diode thyristor; varactor	K relay	TB terminal board	Z tuned cavity; tuned circuit
DC directional coupler	L coil; inductor	TC thermocouple	
DL delay line	M meter	TP test point	
DS annunciator; signaling device (audible or visual); lamp; LED	MP miscellaneous mechanical part		

ABBREVIATIONS

A ampere	COEF coefficient	EDP electronic data processing	INT internal
ac alternating current	COM common	ELECT electrolytic	kg kilogram
ACCESS accessory	COMP composition	ENCAP encapsulated	kHz kilohertz
ADJ adjustment	COMPL complete	EXT external	k Ω kilohm
A/D analog-to-digital	CONN connector	F farad	kV kilovolt
AF audio frequency	CP cadmium plate	FET field-effect transistor	lb pound
AFC automatic frequency control	CRT cathode-ray tube	F/F flip-flop	LC inductance-capacitance
AGC automatic gain control	CTL complementary transistor logic	FH flat head	LED light-emitting diode
AL aluminum	CW continuous wave	FIL H fillister head	LF low frequency
ALC automatic level control	cm centimeter	FM frequency modulation	LG long
AM amplitude modulation	D/A digital-to-analog	FP front panel	LH left hand
AMPL amplifier	dB decibel	FREQ frequency	LIM limit
APC automatic phase control	dBm decibel referred to 1 mW	FXD fixed	LIN linear taper (used in parts list)
ASSY assembly	dc direct current	g gram	lin linear
AUX auxiliary	deg degree (temperature interval or difference)	GE germanium	LK WASH lock washer
avg average	° degree (plane angle)	GHz gigahertz	LO low; local oscillator
AWG American wire gauge	°C degree Celsius (centigrade)	GL glass	LOG logarithmic taper (used in parts list)
BAL balance	°F degree Fahrenheit	GRD ground(ed)	log logarithmic
BCD binary coded decimal	°K degree Kelvin	H henry	LPF low pass filter
BD board	DEPC deposited carbon	h hour	LV low voltage
BE CU beryllium copper	DET detector	HET heterodyne	m meter (distance)
BFO beat frequency oscillator	diam diameter	HEX hexagonal	mA milliampere
BH binder head	DIA diameter (used in parts list)	HD head	MAX maximum
BKDN breakdown	DIFF AMPL differential amplifier	HOW hardware	M Ω megohm
BP bandpass	div division	HF high frequency	MEG meg (10 ⁶) (used in parts list)
BPF bandpass filter	DPDT double-pole, double-throw	HG mercury	MET FLM metal film
BRS brass	DR drive	HI high	MET OX metallic oxide
BWO backward-wave oscillator	DSB double sideband	HP Hewlett-Packard	MF medium frequency; microfarad (used in parts list)
CAL calibrate	DTL diode transistor logic	HPF high pass filter	MFR manufacturer
ccw counter-clockwise	DVM digital voltmeter	HR hour (used in parts list)	mg milligram
CER ceramic	ECL emitter coupled logic	HV high voltage	MHz megahertz
CHAN channel	EMF electromotive force	Hz Hertz	mH millihenry
cm centimeter		IC integrated circuit	mho mho
CMO cabinet mount only		ID inside diameter	MIN minimum
COAX coaxial		IF intermediate frequency	min minute (time)
		IMPG impregnated minute (plane angle)
		in inch	MINAT miniature
		INCD incandescent	mm millimeter
		INCL include(s)	
		INP input	
		INS insulation	

NOTE

All abbreviations in the parts list will be in upper-case.

Table 6-2. Reference Designations and Abbreviations (cont'd)

MOD modulator	OD outside diameter	PWV peak working voltage	TD time delay
MOM momentary	OH oval head	RC resistance-capacitance	TERM terminal
MOS metal-oxide semiconductor	OP AMPL operational amplifier	RECT rectifier	TFT thin-film transistor
ms millisecond	OPT option	REF reference	TGL toggle
MTG mounting	OSC oscillator	REG regulated	THD thread
MTR meter (indicating device)	OX oxide	REPL replaceable	THRU through
mV millivolt	oz ounce	RF radio frequency	TI titanium
mVac millivolt, ac	Ω ohm	RFI radio frequency interference	TOL tolerance
mVdc millivolt, dc	P peak (used in parts list)	RH round head: right hand	TRIM trimmer
mVpk millivolt, peak	PAM pulse-amplitude modulation	RLC resistance-inductance-capacitance	TSTR transistor
mVp-p millivolt, peak-to-peak	PC printed circuit	RMO rack mount only	TTL transistor-transistor logic
mVrms millivolt, rms	PCM pulse-code modulation; pulse-count modulation	rms root-mean-square	TV television
mW milliwatt	PDM pulse-duration modulation	RND round	TVI television interference
MUX multiplex	pF picofarad	ROM read-only memory	TWT traveling wave tube
MY mylar	PH BRZ phosphor bronze	R&P rack and panel	U micro (10^{-6}) (used in parts list)
μ A microampere	PHL Phillips	RWV reverse working voltage	UF microfarad (used in parts list)
μ F microfarad	PIN positive-intrinsic-negative	S scattering parameter	UHF ultrahigh frequency
μ H microhenry	PIV peak inverse voltage	s second (time)	UNREG unregulated
μ mho micromho	pk peak	" second (plane angle)	V volt
μ s microsecond	PL phase lock	S-B slow-blow (fuse) (used in parts list)	VA voltampere
μ V microvolt	PLO phase lock oscillator	SCR silicon controlled rectifier; screw	Vac volts, ac
μ Vac microvolt, ac	PM phase modulation	SE selenium	VAR variable
μ Vdc microvolt, dc	PNP positive-negative-positive	SECT sections	VCO voltage-controlled oscillator
μ Vpk microvolt, peak	P/O part of	SEMICON semiconductor	Vdc volts, dc
μ Vp-p microvolt, peak-to-peak	POLY polystyrene	SHF superhigh frequency	VDCW volts, dc, working (used in parts list)
μ Vrms microvolt, rms	PORC porcelain	SI silicon	V(F) volts, filtered
μ W microwatt	POS positive; position(s) (used in parts list)	SIL silver	VFO variable-frequency oscillator
nA nanoampere	POSN position	SL slice	VHF very-high frequency
NC no connection	POT potentiometer	SNR signal-to-noise ratio	Vpk volts, peak
N/C normally closed	p-p peak-to-peak	SPDT single-pole, double-throw	Vp-p volts, peak-to-peak
NE neon	PP peak-to-peak (used in parts list)	SPG spring	Vrms volts, rms
NEG negative	PPM pulse-position modulation	SR split ring	VSWR voltage standing wave ratio
nF nanofarad	PREAMPL preamplifier	SPST single-pole, single-throw	VTO voltage-tuned oscillator
NI PL nickel plate	PRF pulse-repetition frequency	SSB single sideband	VTVM vacuum-tube voltmeter
N/O normally open	PRR pulse repetition rate	SST stainless steel	V(X) volts, switched
NOM nominal	ps picosecond	STL steel	W watt
NORM normal	PT point	SQ square	W/ with
NPN negative-positive-negative	PTM pulse-triangular modulation	SWR standing-wave ratio	WIV working inverse voltage
NPO negative-positive zero (zero temperature coefficient)	PWM pulse-width modulation	SYNC synchronize	WW wirewound
NRFR not recommended for field replacement		T timed (slow-blow fuse)	W/O without
NSR not separately replaceable		TA tantalum	YIG yttrium-iron-garnet
ns nanosecond		TC temperature compensating	Z ₀ characteristic impedance
nW nanowatt			
OBD order by description			

NOTE

All abbreviations in the parts list will be in upper-case.

MULTIPLIERS

Abbreviation	Prefix	Multiple
T	tera	10^{12}
G	giga	10^9
M	mega	10^6
k	kilo	10^3
da	deka	10
d	deci	10^{-1}
c	centi	10^{-2}
m	milli	10^{-3}
μ	micro	10^{-6}
n	nano	10^{-9}
p	pico	10^{-12}
f	femto	10^{-15}
a	atto	10^{-18}

Table 6-2. Replaceable Parts

Reference Designation	HP Part Number	Qty	Description	Mfr Code	Mfr Part Number
A1	08503-60042	1	BOARD ASSY, FRONT PANEL SWITCH	28480	08503-60042
A1DS1	1990-0487	1	LED-VISIBLE, YELLOW	28480	1990-0487
A1DS2	1990-0485	1	LED-VISIBLE, GREEN	28480	1990-0485
A1J1	1200-0507	1	SOCKET-IC 16 CONT	06776	ICN-163-S3W
A1SW1			NOT ASSIGNED		
A1SW2	5060-9436	1	SWITCH, PC BOARD (LOCAL)	28480	5060-9436
	5020-3440	1	SPRING, DETENT (LOCAL)	28480	5020-3440
	5040-0122	1	PUSHBUTTON (LOCAL)	28480	5040-0122
A1SW3	08503-20003	1	SWITCH, PC SLIDE (S-PARAMETER SELECT)	28480	08503-20003
A2	5086-7262	1	• SPLITTER/DIRECTIONAL BRIDGE	28480	5086-7262
A2J1			SEE FIGURE 6-2		
A3	5086-7263	1	• DIRECTIONAL BRIDGE ASSY	28480	5086-7263
A3J1			SEE FIGURE 6-2		
A4	08503-60013	1	BOARD ASSY, POWER SUPPLY; DOES NOT INCLUDE A4U1 AND U2	28480	08503-60013
A4C1	0180-2594	1	CAPACITOR-FXD; 7200 UF	28480	0180-2594
A4C2	0180-0116	1	CAPACITOR-FXD; 6.8 UF +-10% 35 VDC TA	56289	150D685X903582
A4C3	0180-0291	2	CAPACITOR-FXD; 1UF +-10% 35 VDC	56289	150D105X9035A2
A4C4	0160-2055	2	CAPACITOR-FXD; .01 UF +80 -20%	28480	0160-2055
A4C5	0160-4298	1	CAPACITOR-FXD; 4700 PF +-20% 250 WVDC CER	56289	C067F251H472MS22-CDH
A4C6	0180-2217	2	CAPACITOR-FXD; 350 UF +75 -10% 50 VDC AL	56289	39D357G050FL4
A4C7	0180-0291		CAPACITOR-FXD; 1 UF +-10% 35 VDC	56289	150D105X9035A2
A4C8	0160-4084	4	CAPACITOR-FXD; .1 UF +-20% 50 WVDC	28480	0160-4084
A4C9	0180-2217		CAPACITOR-FXD; 350 UF +75 -10% 50 VDC AL	56289	39D357G050FL4
A4F1	2110-0003	1	FUSE 3A 250V NORM-BLOW	71400	AGC-3
A4F2	2110-0001	1	FUSE 1A 250V NORM-BLOW	71400	AGC-1
A4J1	1251-3305	2	CONNECTOR, 4-PIN MALE	27264	09-65-1041 (2244-4A)
A4MP1	1400-0249	2	CABLE TIE	06383	PLT1M-M-8
A4MP2	1400-0249		CABLE TIE	06383	PLT1M-M-8
A4R1	0757-0438	1	RESISTOR 5.11K 1% .125W F	24546	C4-1/8-TO-5111-F
A4R2	0757-0279	1	RESISTOR 3.16K 1% .125W F	24546	C4-1/8-TO-3161-F
A4U1	1826-0181	1	IC LM323K REGULATOR	27014	LM323K
A4U2	1826-0203	1	IC REGULATOR	07263	7815KC
A4U3	1906-0021	1	DIODE, BRIDGE RECTIFIER	28480	1906-0021
A4U4	1901-0638	1	DIODE, BRIDGE RECTIFIER	28480	1901-0638
A4VR1	1902-3149	1	DIODE-ZNR 9.09V 5% PD=.4W	04713	SZ 10939-170
A5	08503-60035	1	ASSEMBLY, COAXIAL SWITCH	28480	08503-60035
A6	08503-60012	1	BOARD ASSY, DECODER/DRIVER	28480	08503-60012
A6C1	0180-0197	1	CAPACITOR-FXD; 2.2 UF +-10% 20 VDC TA	56289	150D225X9020A2
A6C2	0160-2055		CAPACITOR-FXD; .01 UF +80 -20% 100 WVDC CER	28480	0160-2055
A6C3	0180-1819	1	CAPACITOR-FXD; 100 UF +75 -10% 50 VDC AL	56289	30D107G050DH2
A6CR1	1901-0539	1	DIODE-SCHOTTKY	28480	1901-0539
A6CR2	1901-0050	14	DIODE-SWITCHING 80V 200MA 2NS	28480	1901-0050
A6CR3	1901-0050		DIODE-SWITCHING 80V 200MA 2NS	28480	1901-0050
A6CR4	1901-0050		DIODE-SWITCHING 80V 200MA 2NS	28480	1901-0050
A6CR5	1901-0050		DIODE-SWITCHING 80V 200MA 2NS	28480	1901-0050
A6CR6	1901-0050		DIODE-SWITCHING 80V 200MA 2NS	28480	1901-0050
A6CR7	1901-0050		DIODE-SWITCHING 80V 200MA 2NS	28480	1901-0050
A6CR8	1901-0050		DIODE-SWITCHING 80V 200MA 2NS	28480	1901-0050
A6CR9	1901-0050		DIODE-SWITCHING 80V 200MA 2NS	28480	1901-0050
A6CR10	1901-0050		DIODE-SWITCHING 80V 200MA 2NS	28480	1901-0050
A6CR11	1901-0050		DIODE-SWITCHING 80V 200MA 2NS	28480	1901-0050
A6CR12	1901-0050		DIODE-SWITCHING 80V 200MA 2NS	28480	1901-0050
*NOT FIELD REPAIRABLE					

Table 6-2. Replaceable Parts (Cont'd)

Reference Designation	HP Part Number	Qty	Description	Mfr Code	Mfr Part Number
A6CR13	1901-0050		DIODE-SWITCHING 80V 200MA 2NS	28480	1901-0050
A6CR14	1901-0050		DIODE-SWITCHING 80V 200MA 2NS	28480	1901-0050
A6CR15	1901-0050		DIODE-SWITCHING 80V 200MA 2NS	28480	1901-0050
A6MP1	4040-0754	2	EXTRACTOR, PC BOARD, BLUE	28480	4040-0754
A6MP2	4040-0754		EXTRACTOR, PC BOARD, BLUE	28480	4040-0754
A6MP3	1480-0059	4	ROLL PIN, EXTRACTOR	00000	OBD
A6MP4	1480-0059		ROLL PIN, EXTRACTOR	00000	OBD
A6R1	0698-3441	2	RESISTOR 215 1% .125 F	16299	C4-1/8-TO-215R-F
A6R2	0698-3441		RESISTOR 215 1% .125 F	16299	C4-1/8-TO-215R-F
A6R3	0757-0199	1	RESISTOR 21.5K 1% .125W F	24546	C4-1/8-TO-2152-F
A6U1	1820-1542	3	IC CD4049AY BUFFER	02735	CD4049AY
A6U2	1820-1542		IC CD4049AY BUFFER	02735	CD4049AY
A6U3	1820-1266	1	IC MM80C 97N BUFFER	27014	MM80C97N
A6U4	1820-0535	5	IC SN75 451BP DRIVER	01295	SN75451BP
A6U5	1820-0535		IC SN75 451BP DRIVER	01295	SN75451BP
A6U6	1820-0535		IC SN75 451BP DRIVER	01295	SN75451BP
A6U7	1820-0535		IC SN75 451BP DRIVER	01295	SN75451BP
A6U8	1820-0535		IC SN75 451BP DRIVER	01295	SN75451BP
A6U9	1810-0207	2	NETWORK-RES 8-PIN-SIP	11236	750-81-R22K
A6U10	1810-0037	1	NETWORK-RES 16-PIN-DIP	11236	760 SERIES/16 PIN
A6U11	1810-0207		NETWORK-RES 8-PIN-SIP	11236	750-81-R22K
A7			NOT ASSIGNED		
A8	08503-60016	1	BOARD ASSY, HP-IB (OPT 001 ONLY)	28480	08503-60016
A8C1	0180-0229	1	CAPACITOR-FXD; 33 UF +-10% 10 VDC TA-SOLID	56289	150D336X9010B2
A8C2	0160-3879	7	CAPACITOR-FXD; .01 UF +-20% 100 WVDC CER	28480	0160-3879
A8C3	0160-3879		CAPACITOR-FXD; .01 UF +-20% 100 WVDC CER	28480	0160-3879
A8C4	0160-3879		CAPACITOR-FXD; .01 UF +-20% 100 WVDC CER	28480	0160-3879
A8C5	0160-3879		CAPACITOR-FXD; .01 UF +-20% 100 WVDC CER	28480	0160-3879
A8C6	0160-3879		CAPACITOR-FXD; .01 UF +-20% 100 WVDC CER	28480	0160-3879
A8C7	0160-3879		CAPACITOR-FXD; .01 UF +-20% 100 WVDC CER	28480	0160-3879
A8C8	0160-4084		CAPACITOR-FXD; .1 UF +-20% 50 WVDC	28480	0160-4084
A8C9	0160-3879		CAPACITOR-FXD; .01 UF +-20% 100 WVDC CER	28480	0160-3879
A8C10	0160-3877	1	CAPACITOR-FXD; 100 PF +-20% 200 WVDC CER	28480	0160-3877
A8C11	0160-4084		CAPACITOR-FXD; .1 UF +-20% 50 WVDC	28480	0160-4084
A8C12	0160-4084		CAPACITOR-FXD; .1 UF +-20% 50 WVDC	28480	0160-4084
A8CR1	1901-0033	1	DIODE-GEN PRP 180V 200 MA	28480	1901-0033
A8L1	08503-80001	1	COIL, TOROID	28480	08503-80001
A8MP1	4040-0747	2	EXTRACTOR, PC BOARD, GRAY	28480	4040-0747
A8MP2	4040-0747		EXTRACTOR, PC BOARD, GRAY	28480	4040-0747
A8MP3	1480-0059		ROLL PIN, EXTRACTOR	00000	OBD
A8MP4	1480-0059		ROLL PIN, EXTRACTOR	00000	OBD
A8R1	0698-7260	1	RESISTOR 10K 2% .05W F	24546	C3-1/8-TO-1002-G
A8R2	0757-0465	2	RESISTOR 100K 1% .125W F	24546	C4-1/8-TO-1003-F
A8R3	0757-0465		RESISTOR 100K 1% .125W F	24546	C4-1/8-TO-1003-F
A8R4	0757-0280	1	RESISTOR 1K 1% .125W F	24546	C4-1/8-TO-1001-F
A8R5	0698-7230	2	RESISTOR 562 2% .05W F	24546	C3-1/8-TO-562R-G
A8R6	0698-7230		RESISTOR 562 2% .05W F	24546	C3-1/8-TO-562R-G
A8U1	1820-1144	2	IC SN74LS 02 N GATE	01295	SN74LS02N
A8U2	1820-1201	1	IC SN74LS 08 N GATE	01295	SN74LS08N
A8U3	1820-1194	1	IC SN74LS193N COUNTER	01295	SN74LS193N

Table 6-2. Replaceable Parts (Cont'd)

Reference Designation	HP Part Number	Qty	Description	Mfr Code	Mfr Part Number
A8U4	1820-1205	1	IC SN74LS 21 N GATE	01295	SN74LS21N
A8U5	1820-1544	1	IC CD4076BY FLIP-FLOP	02735	CD4076BY
A8U6			NOT ASSIGNED		
A8U7	1810-0204	1	NETWORK-RES 8-PIN-SIP	11236	750-81-R1K
A8U8	1820-1546	1	IC CD4052AY MUXR	02735	CD4052AY
A8U9	1820-1112	1	IC SN74LS 74 N FLIP-FLOP	01295	SN74LS74N
A8U10	1820-1144		IC SN74LS 02 N GATE	01295	SN74LS02N
A8U11	1820-1199	1	IC SN74LS 04 N INV	01295	SN74LS04N
A8U12	1820-1202	1	IC SN74LS 10 N GATE	01295	SN74LS10N
A8U13	1820-1206	1	IC SN74LS 27 N GATE	01295	SN74LS27N
A8U14	1820-0904	1	IC COMPARATOR	07263	93L24DC
A8U15	1820-1542		IC CD4049AY BUFFER	02735	CD4049AY
A8U16	1820-1212	1	IC SN74LS112 N FLIP-FLOP	01295	SN74LS112N
A8U17	1820-1197	1	IC SN74LS 00 N GATE	01295	SN74LS00N
A8U18	1820-1522	4	IC MC 3440P DIGITAL	04713	MC3440P
A8U19	1820-1522		IC MC 3440P DIGITAL	04713	MC3440P
A8U20	1820-1522		IC MC 3440P DIGITAL	04713	MC3440P
A8U21	1820-1522		IC MC 3440P DIGITAL	04713	MC3440P
A8U22	1820-1244	1	IC SN74LS153 N DATA SEL	01295	SN74LS153N
A9			NOT ASSIGNED		
A10	08503-60011	1	BOARD ASSY, INTERCONNECT	28480	08503-60011
A10J1	1251-3141	1	CONNECTOR, 50-PIN M RECTANGULAR	76381	3433-1002
A10J2	1251-0064	1	CONNECTOR, 25-PIN F D SERIES	71785	DBM-25S
A10J3	1251-3283	1	CONNECTOR, 24-CONT FEM MICRORIBBON	28480	1251-3283
A11			NOT ASSIGNED		
A12	08503-60041	1	BOARD ASSY, MOTHER	28480	08503-60041
A12J1			NOT REPLACEABLE		
A12J2			NOT REPLACEABLE		
A12J3	1251-3305		CONNECTOR, 4-PIN MALE	27264	09-65-1041 (2244-4A)
A12J4	1251-3751	1	CONNECTOR, 8-PIN MALE	27264	09-65-1081
A12XA4	1251-0478	1	CONNECTOR-PC 12 CONTACT	71785	252-06-30-340
A12XA5			NOT ASSIGNED		
A12XA6	1251-1887	3	CONNECTOR, PC 44 CONTACT	71785	252-22-30-340
A12XA7			NOT ASSIGNED		
A12XA8	1251-1887		CONNECTOR, PC 44 CONTACT	71785	252-22-30-340
A12XA9	1251-1887		CONNECTOR, PC 44 CONTACT	71785	252-22-30-340
CHASSIS PARTS					
F1	2110-0012	1	FUSE .5A 250V (100-120V)	71400	AGC 1/2
	2110-0004		FUSE .25A 250V (220-240V)	71400	AGC 1/4
FL1	0960-0443	1	LINE MODULE ASSY	28480	0960-0443
J1			} SEE FIGURE 6-1		
J2					
J3					
J4					
J5	1250-0083	2	CONNECTOR, BNC (DC BIAS)		
J6	1250-0083		CONNECTOR, BNC (DC BIAS)		
P1	1251-3167	2	CONNECTOR, 4-PIN FEMALE (TRANSFORMER)	27264	09-50-3041
	1251-0679	4	CONTACT, CONNECTOR FEMALE	27264	08-50-0106
P2	1251-3167		CONNECTOR, 4-PIN FEMALE (COAXIAL SWITCH)	27264	09-50-3041
	1251-2992	3	CONTACT, CONNECTOR FEMALE	27264	08-50-0106
S1	3101-2025	1	SWITCH, DPST (LINE)	28480	3101-2025
T1	9100-3847	1	TRANSFORMER	28480	9100-3847
W1	8120-1348	1	CABLE, AC POWER	28480	8120-1348
W2	08503-60001	1	CABLE, RIBBON (M.B. TO F.P.)	28480	08503-60001
W3	08503-60003	1	CABLE, RIBBON (M.B. TO R.P.)	28480	08503-60003
W4	08503-20033	1	CABLE, COAXIAL (A2 TO A5)	28480	08503-20033
W5	08503-20032	1	CABLE, COAXIAL (A2 TO A5)	28480	08503-20032

Table 6-2. Replaceable Parts (Cont'd)

Reference Designation	HP Part Number	Qty	Description	Mfr Code	Mfr Part Number
W6	08503-20034	1	CABLE, COAXIAL (A3 TO A5)	28480	08503-20034
W7	08503-20031	1	CABLE, COAXIAL (A2 TO RF PORT)	28480	08503-20031
W8	08503-20035	1	CABLE, COAXIAL (A2 TO PORT A)	28480	08503-20035
W9	08503-20037	1	CABLE, COAXIAL (A2 TO BLK HD)	28480	08503-20037
W10	08503-20038	1	CABLE, COAXIAL LOOP	28480	08503-20038
W11	08503-20039	1	CABLE, COAXIAL (BLK HD TO PORT R)	28480	08503-20039
W12	08503-20036	1	CABLE, COAXIAL (A3 TO PORT B)	28480	08503-20036
W13	08503-60004	1	CABLE, AC LINE SWITCH	28480	08503-60004
MISCELLANEOUS					
	8120-2289	4	CABLE, RF CONNECTING	28480	8120-2289
	08503-60005	1	CABLE, SIG PROC INTERCONN	28480	08503-60005
	10631A	1	CABLE, HP-IB INTERCONN	28480	10631A
	08503-60044	1	EXTENDER BOARD	28480	08503-60044
	5040-7221	4	FOOT, REAR	28480	5040-7221
	1600-0367	4	LOCK LINK, VERTICAL	28480	1600-0367
	08505-20155	1	LOCK FOOT, UPPER LEFT	28480	08505-20155
	08505-20156	1	LOCK FOOT, LOWER LEFT	28480	08505-20156
	08505-20157	1	LOCK FOOT, UPPER RIGHT	28480	08505-20157
	08505-20158	1	LOCK FOOT, LOWER RIGHT	28480	08505-20158

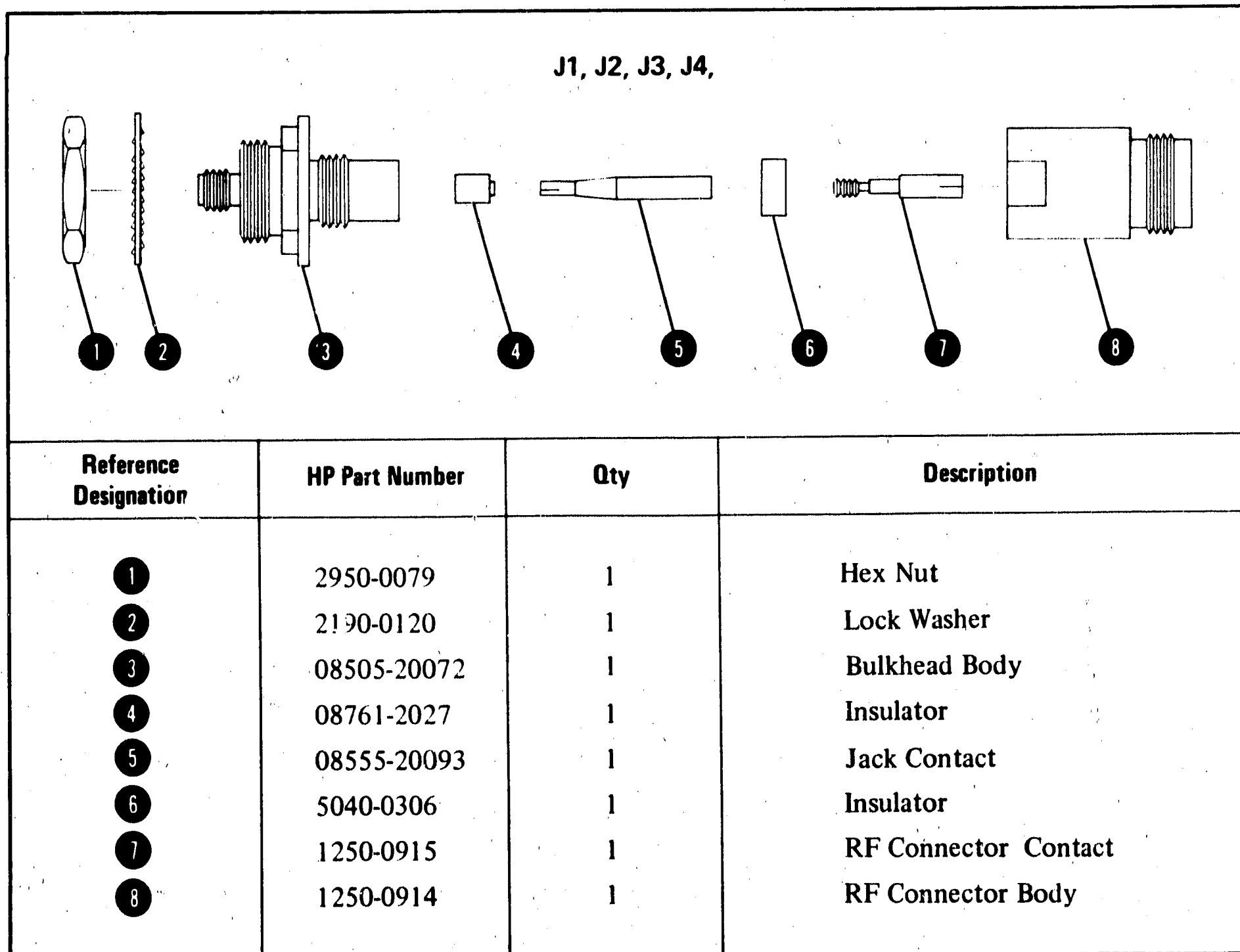
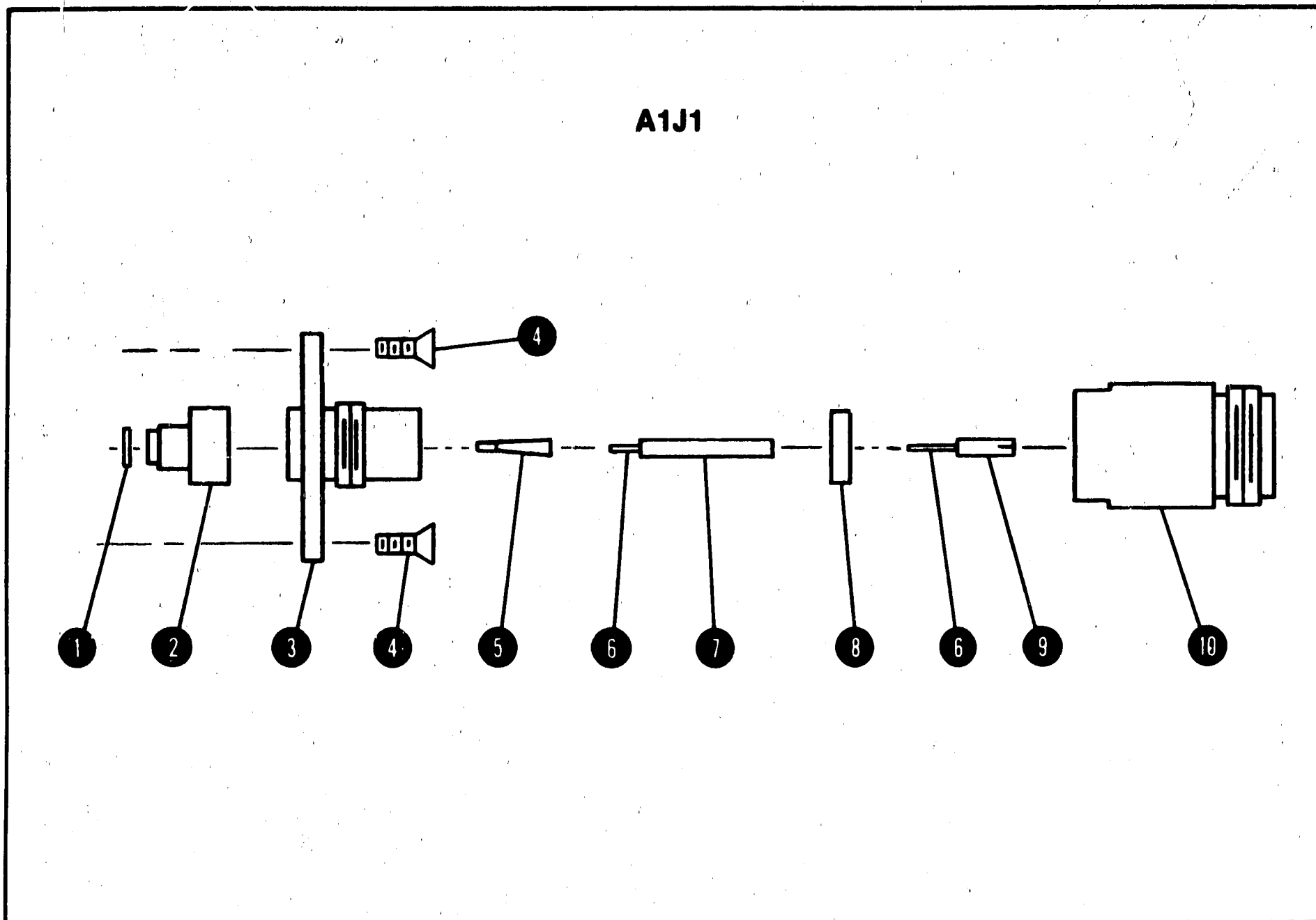

Figure 6-1. Type N 50-Ohm Connector Assembly, Exploded View



Reference Designation	HP Part Number	Qty	Description
1	5021-0941	1	Spacer Washer
2	5020-9107	1	Outer Conductor
3	1250-1450	1	Connector Bulkhead Body
4	2200-0166	2	Machine Screw 4-40, .312-in. FLPD
5	5021-0949	1	Inner Conductor
6	0470-0013	1	Screw Thread Locking Adhesive
7	5021-0940	1	Test Port Extender
8	5020-8593	1	Bead Insulator, 75 Ohms (Z)
9	5021-0912	1	75-Ohm RF Connector, Female
10	1250-0914	1	Type N Female Connector Body

Figure 6-2. Type N 75-Ohm Female Connector Assembly, Exploded View

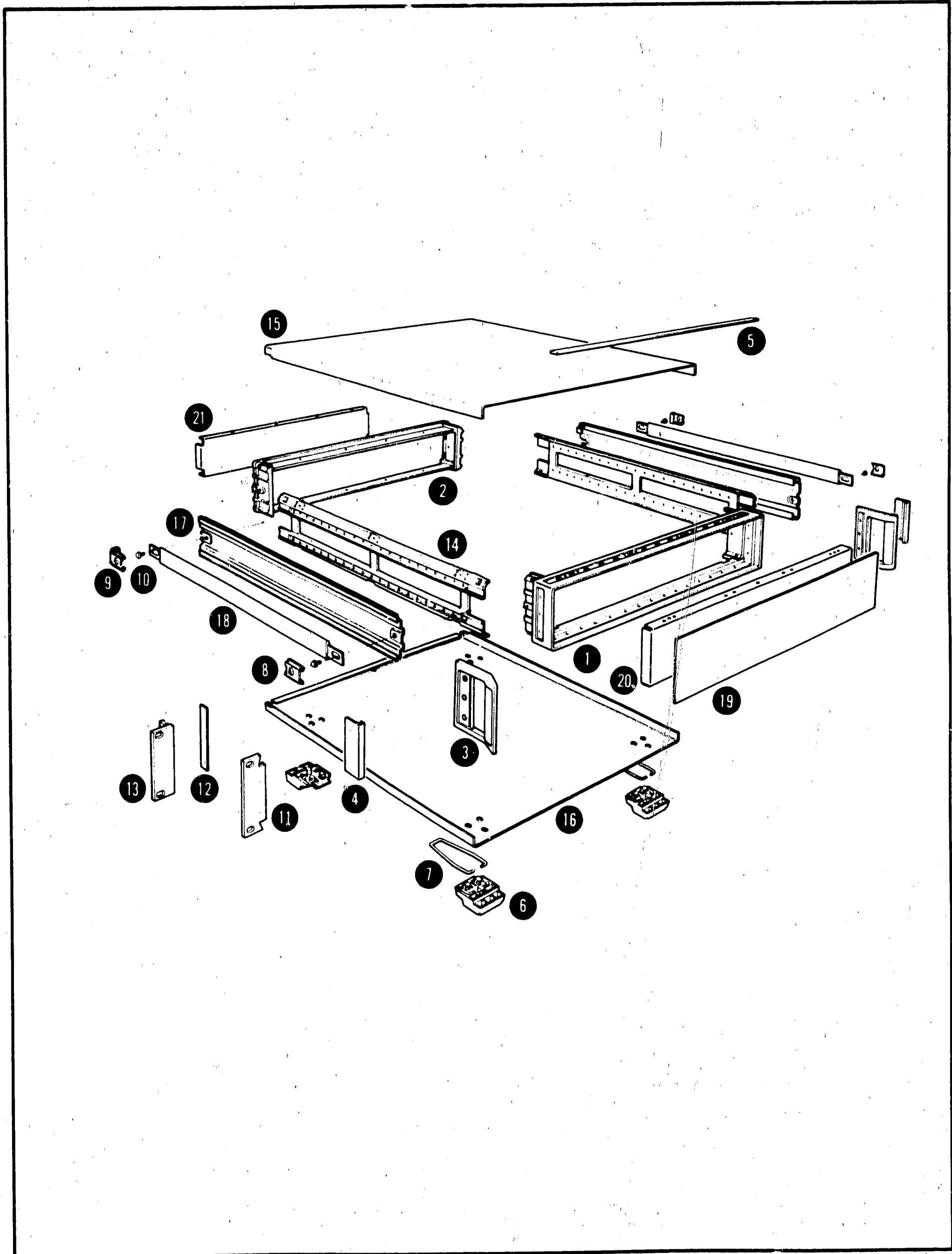

Figure 6-3. Cabinet Parts, Exploded View (1 of 2)

Reference Designation	HP Part Number	Qty	Description
1	5020-8801	1	Frame, Front
2	5020-8802	1	Frame, Rear
3	5060-9898	2	Front Handle Assembly
4	5020-8895	2	Trim, Front Handle
5	5040-7202	1	Top Trim, Front Frame
6	5040-7201	4	Foot
7	1460-1345	2	Tilt Stand
8	5040-7219	2	Front Cap, Strap Handle
9	5040-7220	2	Rear Cap, Strap Handle
10	0570-1170	4	Retainer Screw, Strap Handle
11	5020-8873	2	Rack Flange (with Front Handle)
12	5001-0438	2	Side Trim Front Frame (without Front Handle)
13	5020-8861	2	Rack Flange (without Front Handle)
14	5020-8832	2	Side Strut
15	5060-9835	1	Cover, Top
16	5060-9847	1	Cover, Bottom
17	5060-9876	2	Cover, Side
18	5060-9804	2	Strap Handle Assembly
19	08503-00020	1	Panel, Front Dress
20	08503-00014	1	Panel, Front Sub
21	08503-00003	1	Panel, Rear

Figure 6-3. Cabinet Parts, Exploded View (2 of 2)

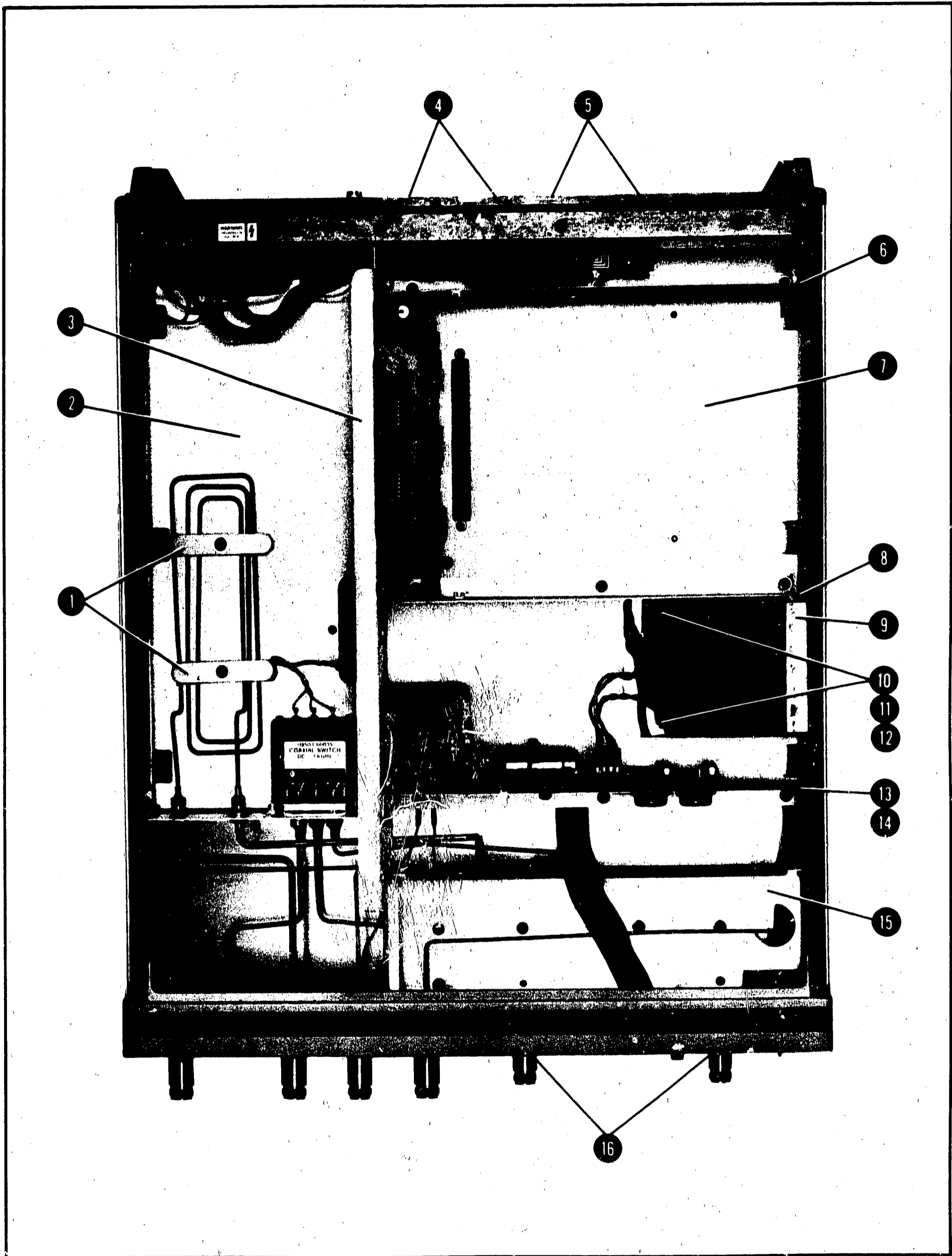

Figure 6-4. Mechanical Parts Location (1 of 2)

Reference Designation	HP Part Number	Qty	Description
1	08503-00011	2	Cable Clamp
2	08503-00005	1	Deck, Main
3	08503-00010	1	Gusset, Deck
4	1251-2942	2	Lock-Submin D Connector
5	0380-0644	2	Standoff-Hex (HP-IB Conn. Lock)
6	08503-00017	1	Gusset, Rear
7	08503-00015	1	Deck, Card Support
8	08503-00016	1	Gusset, Center
9	08503-20001	2	Spacer, Transformer
10	3050-0005	8	Washer, Fiber Shoulder
11	3050-0253	4	Washer, Flat .195-IN ID
12	2360-0101	4	Screw-Mach 6-32 3.25-IN-LG
13	08503-00007	1	Gusset, Power Supply
14	08503-20014	1	Board, Insulator
15	08503-00004	1	Deck, Bridge
16	08503-20008	2	Washer, Dress

Figure 6-4. Mechanical Parts Location (2 of 2)

Table 6-3. Code List of Manufacturers

MFR. NO.	MANUFACTURER NAME	ADDRESS	ZIP CODE
01295	TEXAS INSTR INC SEMICOND CMPNT DIV	DALLAS TX	75231
02735	RCA CORP SOLID STATE DIV	SOMMerville NJ	08876
04713	MOTOROLA SEMICONDUCTOR PRODUCTS	PHOENIX AZ	85008
06776	ROBINSON NUGENT INC	NEW ALBANY IN	47150
07263	FAIRCHILD SEMICONDUCTOR DIV	MOUNTAIN VIEW CA	94040
11236	CTS OF BERNE INC	BERNE IN	46711
16299	CORNING GL WK ELEC CMPNT DIV	RALEIGH NC	27604
24546	CORNING GLASS WORKS (BRADFORD)	BRADFORD PA	16701
27014	NATIONAL SEMICONDUCTOR CORP	SANTA CLARA CA	95051
27264	MOLEX PRODUCTS CO	DOWNERS GROVE IL	60515
28480	HEWLETT-PACKARD CO CORPORATE HQ	PALO ALTO CA	94304
56289	SPRAGUE ELECTRIC CO	NORTH ADAMS MA	01247
71400	BUSSMAN MFG DIV OF MCGRAW-EDISON CO	ST LOUIS MO	63017
71785	TRW ELEK COMPONENTS CINCH DIV	ELK GROVE VILLAGE IL	60007
75915	LITTLEFUSE INC	CHICAGO IL	60618
76381	3M COMPANY	ST PAUL MN	55101

**BACK DATING
MANUAL
CHANGES**

SECTION VII MANUAL CHANGES

7-1. INTRODUCTION

7-2. This section normally contains information for adapting this manual to instruments for which the content does not apply directly. Since this manual does apply directly to instruments having serial numbers listed on the title page, no change information is given here. Refer to **INSTRUMENTS COVERED BY MANUAL** in Section I for additional important information about serial number coverage.

SERVICE

INFORMATION

SECTION VIII SERVICE

8-1. INTRODUCTION

WARNING

Servicing of the instrument with covers removed must only be performed by trained service personnel.

8-2. This section provides instructions for troubleshooting and repairing the Model 8503B S-Parameter Test Set. Circuit descriptions and simplified block diagrams are included with the schematic diagrams of the assemblies. Component location illustrations are also contained in this section. Schematic presentations in this manual show electrical circuit operation and are not intended to serve as wiring diagrams.

8-3. ASSEMBLY SERVICE SHEETS

8-4. The schematics are arranged by service sheets, each one pertaining to a particular subassembly (pc board). The service sheet numbers appear in the lower right-hand corners of the subassembly schematics (large number above assembly number). Included in the service sheet with the schematic is the assembly circuit theory, component-parts locations diagram, simplified block diagram, and schematic-level troubleshooting.

8-5. THEORY OF OPERATION

8-6. Detail circuit description for each schematic diagram is placed on the facing left-hand foldout page. This places material needed for printed-circuit-level diagnosis in one location and allows easy correlation between function and specific circuitry.

8-7. TROUBLESHOOTING

8-8. Troubleshooting is generally divided into two maintenance levels in this manual. The first level isolates a trouble to a circuit or assembly. This is done by using troubleshooting block diagrams that provide signal levels and techniques to isolate the cause of a malfunction and identify the defective assembly.

8-9. The second maintenance level isolates the trouble to the component. Schematic diagrams and circuit descriptions for each assembly aid in troubleshooting to the component level.

8-10. When troubleshooting a transistor stage, check for a forward bias condition of the base-emitter junction. If this condition exists, the next step is to remove this forward bias by shorting the base to the emitter and checking to see if the collector voltage rises to the approximate level of the supply. The next check that can be made, if it is known that the transistor is not operating in a saturated condition, is to check for a voltage drop between emitter and collector. These serve only as quick checks, but will help in getting started locating the problem.

8-11. RECOMMENDED TEST EQUIPMENT

8-12. Test equipment and accessories required to maintain the Model 8503B are listed in Table 1-6. If the equipment listed is not available, equipment that meets the minimum specifications shown may be substituted.

8-13. REPAIR

8-14. Directional Bridges

8-15. Splitter/Directional Bridge A2 and Directional Bridge A3 are not field-repairable. If one of these units fails, return the defective unit to the nearest Hewlett-Packard office or service center. You can, however, repair the Type N connectors on A2 and A3. See Figure 6-2 for exploded view and part numbers.

8-16. After Service Product Safety Checks

8-17. Visually inspect interior of instrument for any signs of abnormal internally generated heat, such as discolored printed circuit boards or components, damaged insulation, or evidence of arcing. Determine and remedy cause of any such condition.

8-18. Using a suitable ohmmeter, check resistance from instrument enclosure to ground pin on power cord plug. The reading must be less than one ohm. Flex the power cord while making this measurement to determine whether intermittent discontinuities exist.

8-19. Check resistance from instrument enclosure

to line and neutral (tied together) with the line switch ON and the power source disconnected. The minimum acceptable resistance is two megohms. Replace any component which results in failure to meet this minimum.

8-20. Check line fuse to verify that a correctly rated fuse is installed.

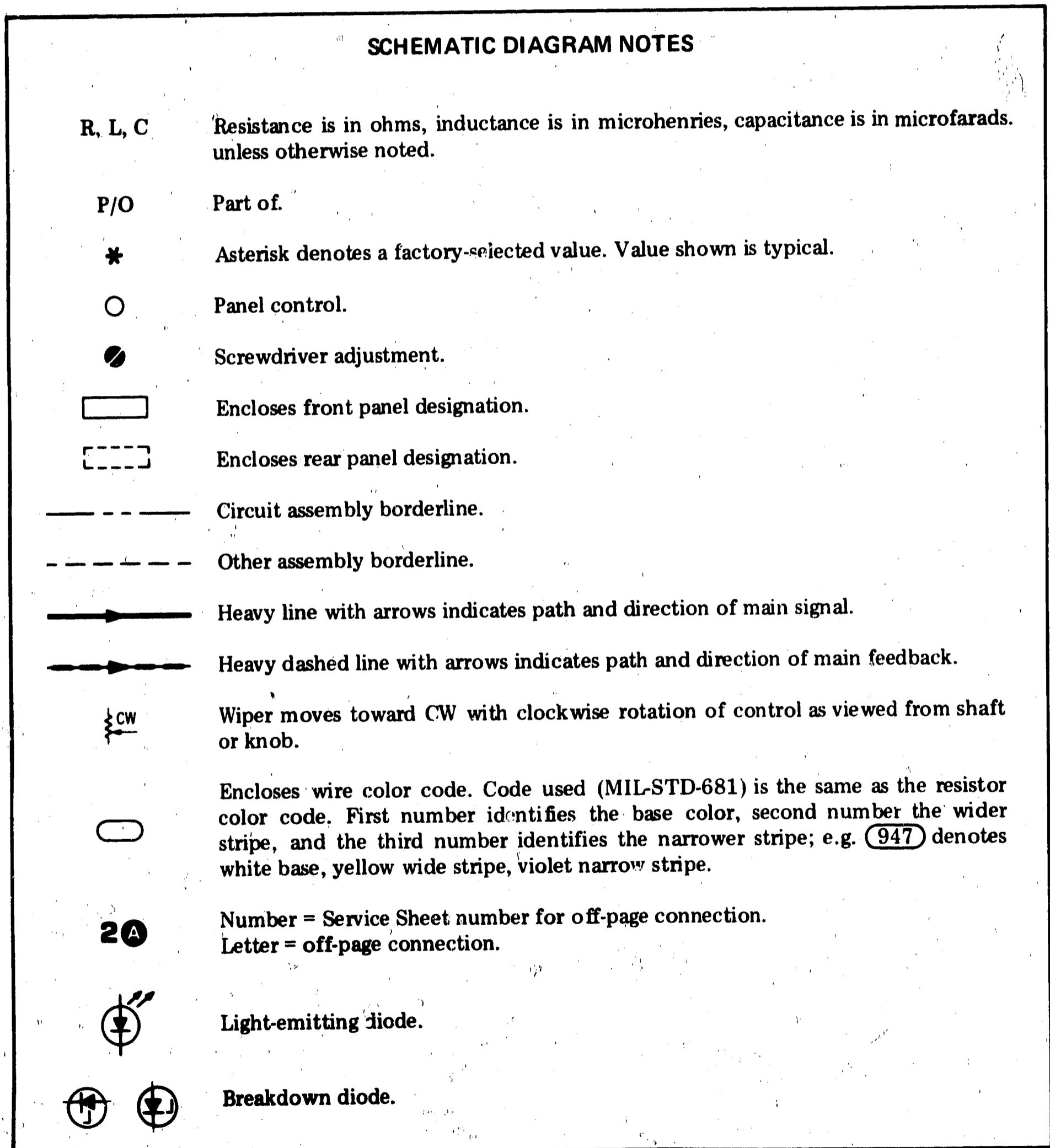

Figure 8-1. Schematic Diagram Notes (1 of 3)

SCHEMATIC DIAGRAM NOTES

Test point location. Number denotes test point number.



Assembly ground.



Chassis ground.



Earth ground.



Indicates "WARNING: HAZARDOUS VOLTAGE."



Refers serviceman or operator to CAUTIONS in Operating and Service Manual.

Voltages noted within circuits are $\pm 10\%$ tolerance unless otherwise stated.

Conditions for dc voltages on schematics are as follows:

- a. 8503B with no interconnections to Network Analyzer.
- b. 8503B S-PARAMETER SELECT switch in FORWARD position and LINE switch ON.

Figure 8-1. Schematic Diagram Notes (2 of 3)

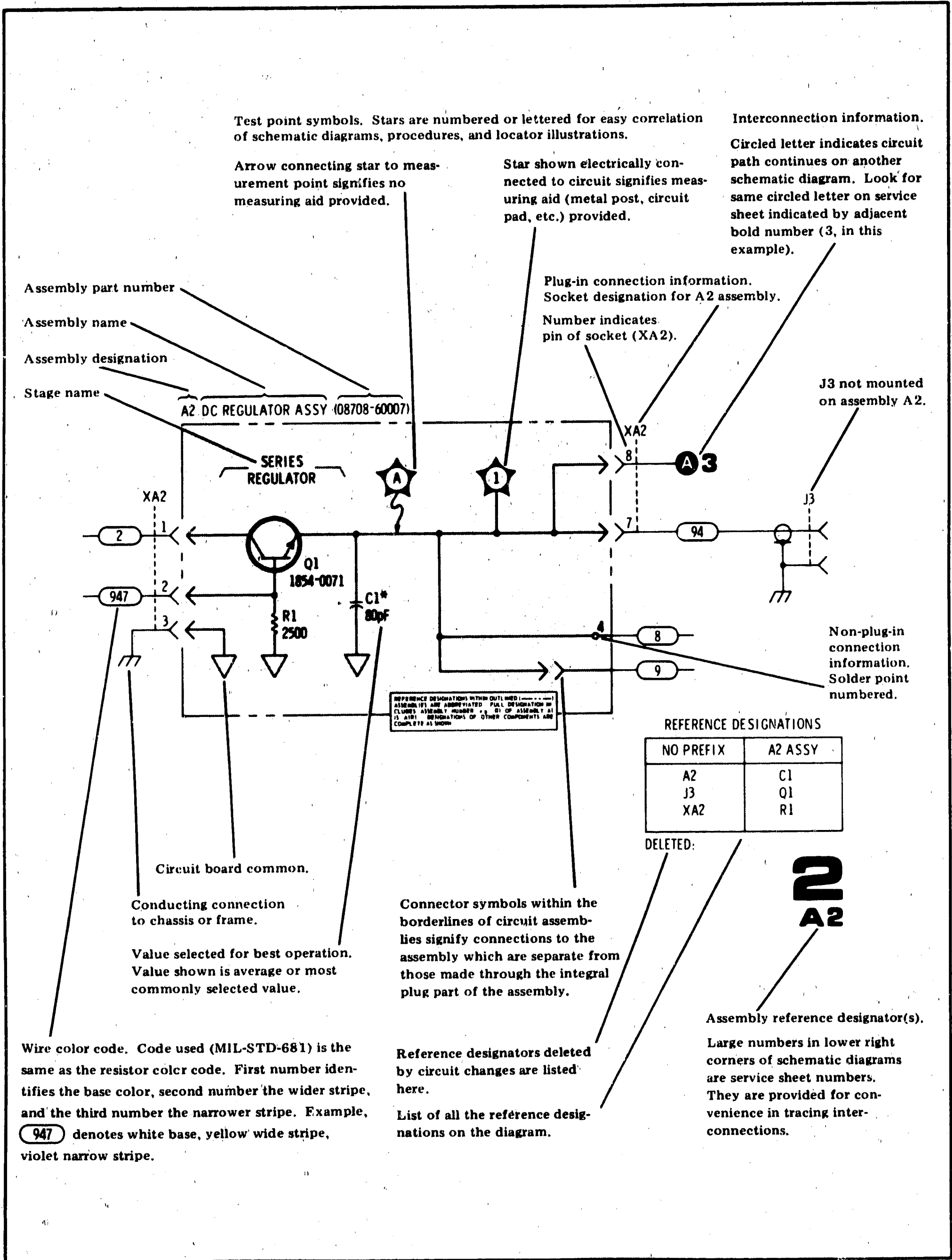

Figure 8-1. Schematic Diagram Notes (3 of 3)

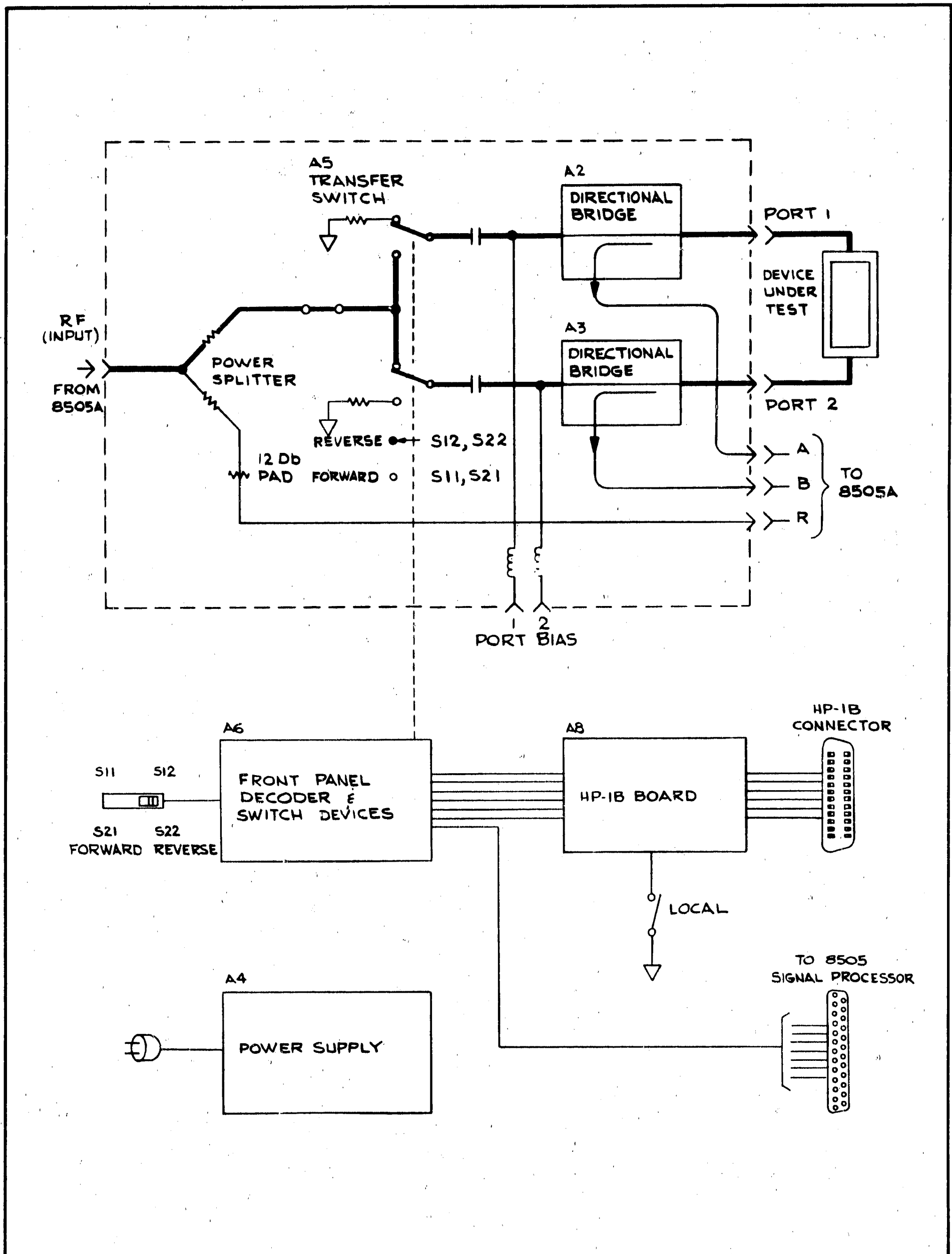

Figure 8-2. Simplified Block Diagram of 8503B, Including Option 001 (HP-IB)

OVERALL TROUBLESHOOTING PROCEDURE

- a. If failure is in RF path, refer to RF Troubleshooting Procedure.
- b. If front-panel switches or indicators have failed, refer to Switch and Indicator Control Troubleshooting Procedure.
- c. If failure is in HP-IB circuitry, refer to Service Sheet 3, HP-IB Circuit Description.

RF TROUBLESHOOTING PROCEDURE

- a. Check directivity of both directional bridges. (See Section II, Figure 2-6). If directivity is less than 40 dB, tighten connectors on directional bridges and check PORT 1 and PORT 2 connectors for possible damage to center conductor. Recheck directivity. If directivity is still less than 40 dB, replace directional bridge.
- b. Apply an RF signal of 0 dBm at approximately 1000 MHz to the 8503B RF input port. The 8505A Source/Converter is a convenient source.
- c. Disconnect RF cables one at a time and check for power levels indicated in Figure 8-3. When checking signal level at Coaxial Switch outputs, switch 8503B S-PARAMETER SELECT switch to insure that A5 is functioning properly.

SWITCH AND INDICATOR CONTROL TROUBLESHOOTING PROCEDURE

- a. Check Power Supply for +5 volts and +24 volts at test points on A4.
- b. With 8503B front-panel S-PARAMETER SELECT switch in the FORWARD position and 8503B in LOCAL mode, check for proper indications as shown in Figure 8-4.
- c. Set front-panel S-PARAMETER SELECT Switch to REVERSE and check for proper indications (all LOW's shown in Figure 8-4 should now be HI and all HI's should be LOW).

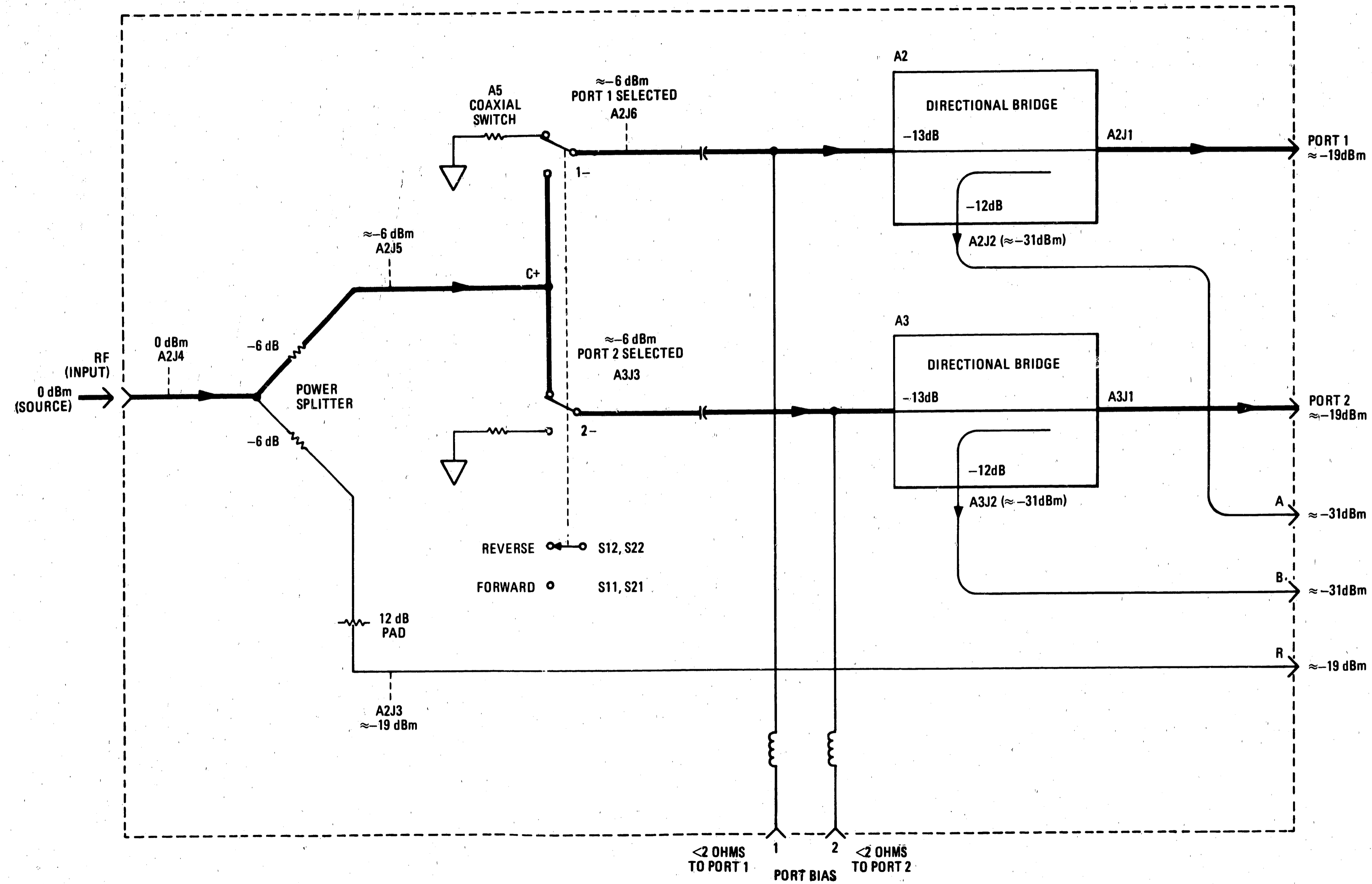

Figure 8-3. RF Troubleshooting Block Diagram

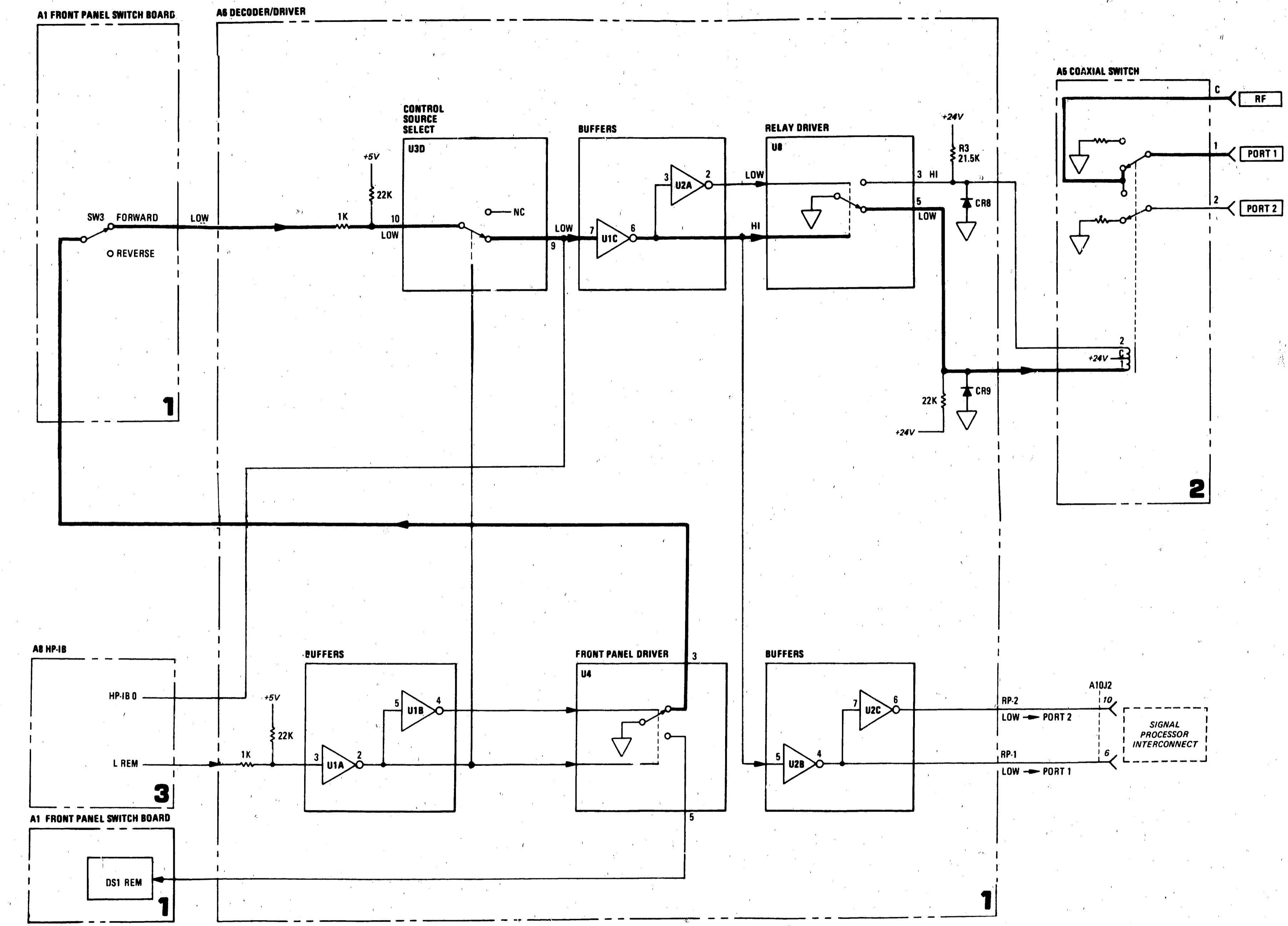

Figure 8-4. Switch Control and Front Panel Indicator Troubleshooting Block Diagram

SERVICE SHEET 1**A1 FRONT PANEL SWITCHBOARD ASSEMBLY
CIRCUIT DESCRIPTION**

The Front Panel Switch Board Assembly is the source for selecting PORT 1 or PORT 2 (FORWARD or REVERSE, respectively) in the LOCAL mode. When S-PARAMETER SELECT switch A1SW3 is in the FORWARD position, a low ($\approx +0V$) is placed at the input of A6U3D (pin 10) resulting in selection of PORT 1. When the S-PARAMETER SELECT switch is in the REVERSE position, the low is removed and input of A6U3D is pulled high ($\approx +5V$) resulting in selection of PORT 2.

The Front Panel switch Board also contains two LED indicators, A1DS1 and A1DS2, and a LOCAL reset pushbutton switch A1SW2. Indicator A1DS1 is lit when the 8503B is in the REMOTE mode. A1DS2 is lit when 8503B LINE switch is ON and +5 volts is available from Power Supply Assembly A4. LOCAL reset pushbutton switch A1SW2 transfers control of Coaxial Switch A5 from the HP-IB to front-panel S-PARAMETER SELECT switch A1SW3. It overrides the REM signal from HP-IB assembly A8 and returns the 8503B Option 001 to LOCAL Mode. Once the LOCAL Pushbutton is pressed, the 8503B will remain in LOCAL mode until again programmed to REMOTE by the operator's input to the calculator.

A6 DECODER/DRIVER ASSEMBLY, CIRCUIT DESCRIPTION**General**

The Decoder/Driver Assembly provides four major functions:

1. Selection of control source (REMOTE or LOCAL).
2. Buffering.
3. Driving (Coaxial Switch A5 and front panel REM indicator).
4. Protection of drivers.

Control Source Select

Integrated circuit U3 is a tri-state buffer. U3D is used to select the source to control Coaxial Switch A5. In LOCAL Mode, U1A pin 3 is pulled high through resistor package U9. The output of U1A pin 2 is, therefore, pulled low. This places a low on pin 1 of U3D and a low on U4 pin 2 allowing A1SW3 to control the port selection. The low at U4 pin 2 is NANDed with a high at U4 pin 1. The base of the top transistor of U4 is therefore high (transistor turned on) and U4 pin 3 is virtually grounded. When the 8503B is programmed to go to REMOTE Mode, the L REM line (XA6 pin 14) pulls U1A pin 3 low. The output of U1A (pin 2) is therefore pulled high. This places a high on pin 1 of U3D which gates U3D off. Thus, the input from S-PARAMETER SELECT switch A1SW3 is disabled, allowing the HP-IB to control the port selection. U3A, U3B, U3C, U3E, and U3F are presently not used in the 8503B.

Front Panel Drivers

In LOCAL Mode, U1A pin 3 is pulled high through resistor package U9. The output of U1A is, therefore, pulled low placing a high at U4 pin 6 (inverted output of U1B). The high on U4 pin 6 is NANDed with the high on U4 pin 7, placing a low at the base of the bottom transistor of U4. This places U4 pin 5 at a high impedance to ground (open) and A1DS1 will not be on.

In REMOTE mode, U1A pin 3 is pulled low (L REM line) so its output (pin 2) is high. This places a low at U4 pin 6, which places a high at the base of the bottom transistor of U4 (transistor turned on). In this state U4 pin 5 is virtually grounded, completing the path for REM indicator A1DS1 to light.

Buffers

Integrated circuits U1 and U2 are CMOS buffers which translate the CMOS control bus levels into TTL compatible levels. Two complementary outputs (from U2B pin 4 and U2C pin 6) go to the rear-panel SIGNAL PROCESSOR INTERCONNECT for interface to companion instruments such as the 8505A. These two lines, RP-1 and RP-2, tell the companion instrument which 8503B test port is selected. RP-1 goes low when PORT 1 is selected (FORWARD); RP-2 goes low when PORT 2 is selected (REVERSE). U1A/B/C and U2A/B/C are the only portions of U1 and U2 presently used in the 8503B.

Relay Drivers

Integrated circuit U8 is the only relay driver presently used in the 8503B. Complementary signals at the input (pins 2 and 6) of U8 control the transistor "switches" of U8. When PORT 1 is selected, the bottom transistor is turned on and pin 5 of U8 is near ground potential (low). Pin 3 is pulled high (+24V) through pull-up resistor R3. When PORT 2 is selected, the top transistor is turned on and pin 3 of U8 is near ground potential. Pin 5 is pulled high (+24V) through a pull-up resistor in resistor package U11 (pin 2). Thus, the DR-1 line to Coaxial Switch Assembly A5 is low when PORT 1 is selected and the DR-2 line to A5 is low when PORT 2 is selected.

Driver Protection

Relay driver U8 is protected by diodes CR8, CR9, and two diodes inside Coaxial Switch A5. These four diodes limit the inductive switching transients that occur when the Coaxial Switch current changes.

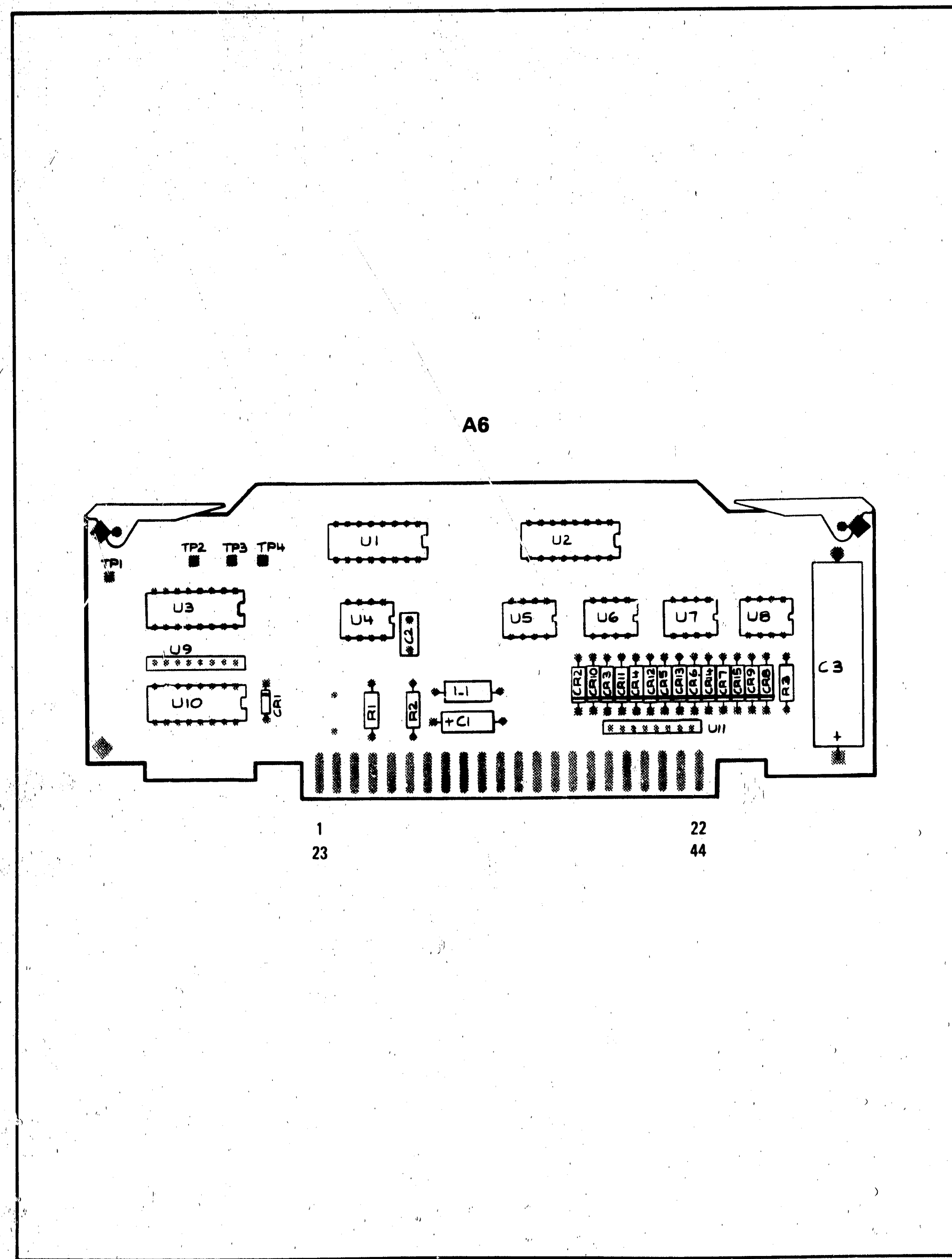
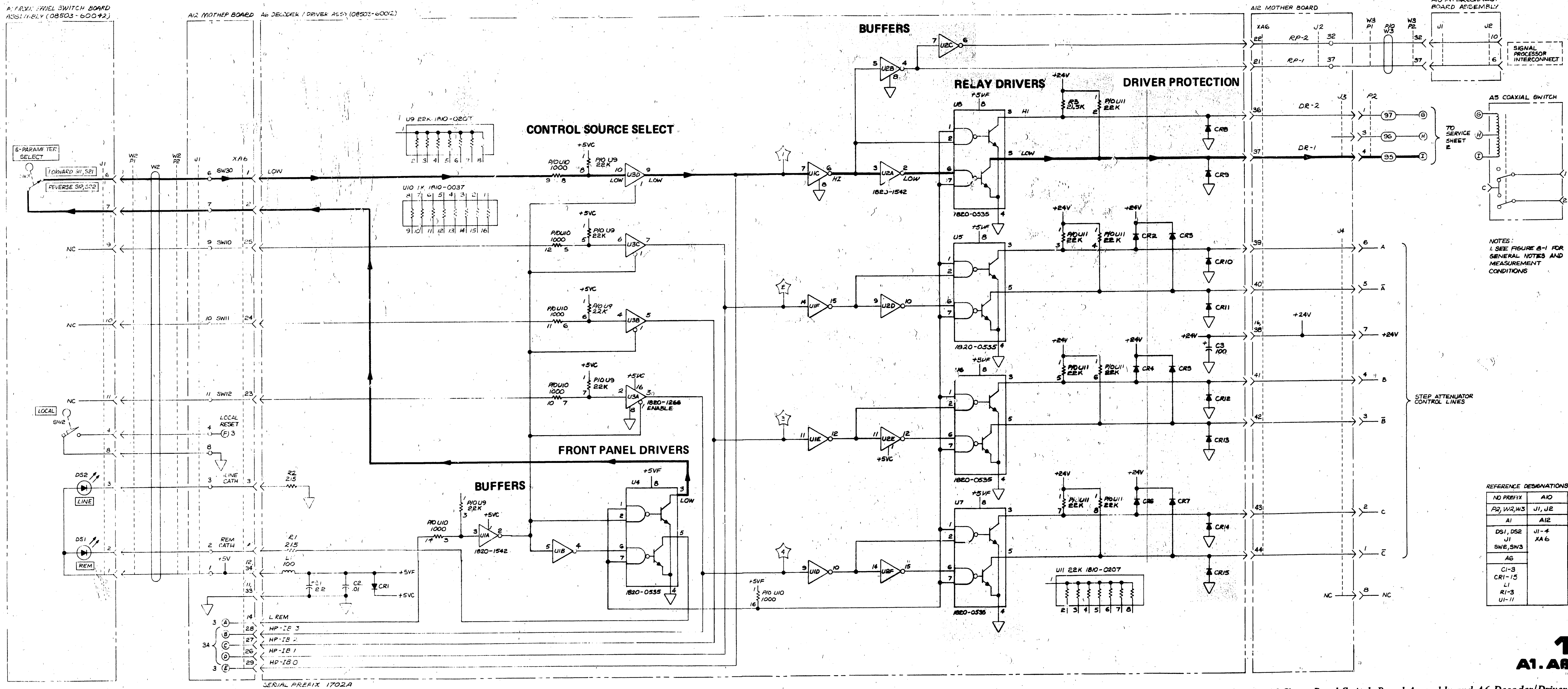

Figure 8-5. A6 Decoder/Driver Assembly, Component Locations



NOTES:
1. SEE FIGURE 8-1 FOR GENERAL NOTES AND MEASUREMENT CONDITIONS

REFERENCE DESIGNATIONS

NO PREFIX	A10
P2, W2, W3	J1, J2
A1	A12
DS1, DS2	U1-4
U1, U2, U3, U4, U5, U6, U7, U8, U9, U10, U11, U12, U13, U14, U15, U16, U17, U18	XA 6
A6	
CR1-15	
U1-11	

Figure 8-6. A1 Front Panel Switch Board Assembly and A6 Decoder/Driver Assembly, Schematic

SERVICE SHEET 2**A2/A3 DIRECTIONAL BRIDGE ASSEMBLIES
CIRCUIT DESCRIPTION****General**

Splitter/Directional Bridge Assembly A2 is essentially the same as Directional Bridge Assembly A3 except that Assembly A2 contains a power splitter.

Power Splitter

The power splitter in Assembly A2 splits the RF input power between the "measurement line" (to Coaxial Switch A5) and the "reference line" (to port R). The signal in the reference line is compensated (Compensating Electrical Length and 12 dB Compensating Pad) so the signal level at port R (from A2J3) will be approximately equal to the level at ports A or B (from A2J2 or A3J2). Coaxial loop W10 makes the reference port path (to port R) approximately one meter longer in electrical length than the paths to the test ports. This one-meter offset permits full utilization of the 8505A Electrical Length line-stretching capability in X10 MODE (+1 to -1 meter at 1300 MHz) outside the test ports of the 8503B.

Directional Bridge

The Directional Bridge of A2 and A3 is a high directivity device (greater than 40 dB, 500 kHz to 1.3 GHz). It is this high directivity that allows reflection measurements (S_{11} , S_{22}) with lowest possible ambiguity. Care should be taken to properly maintain PORT 1 and PORT 2 front-panel connectors. A damaged or dirty connector can degrade the directivity of the Directional Bridge, thus increasing the degree of error in the measurement.

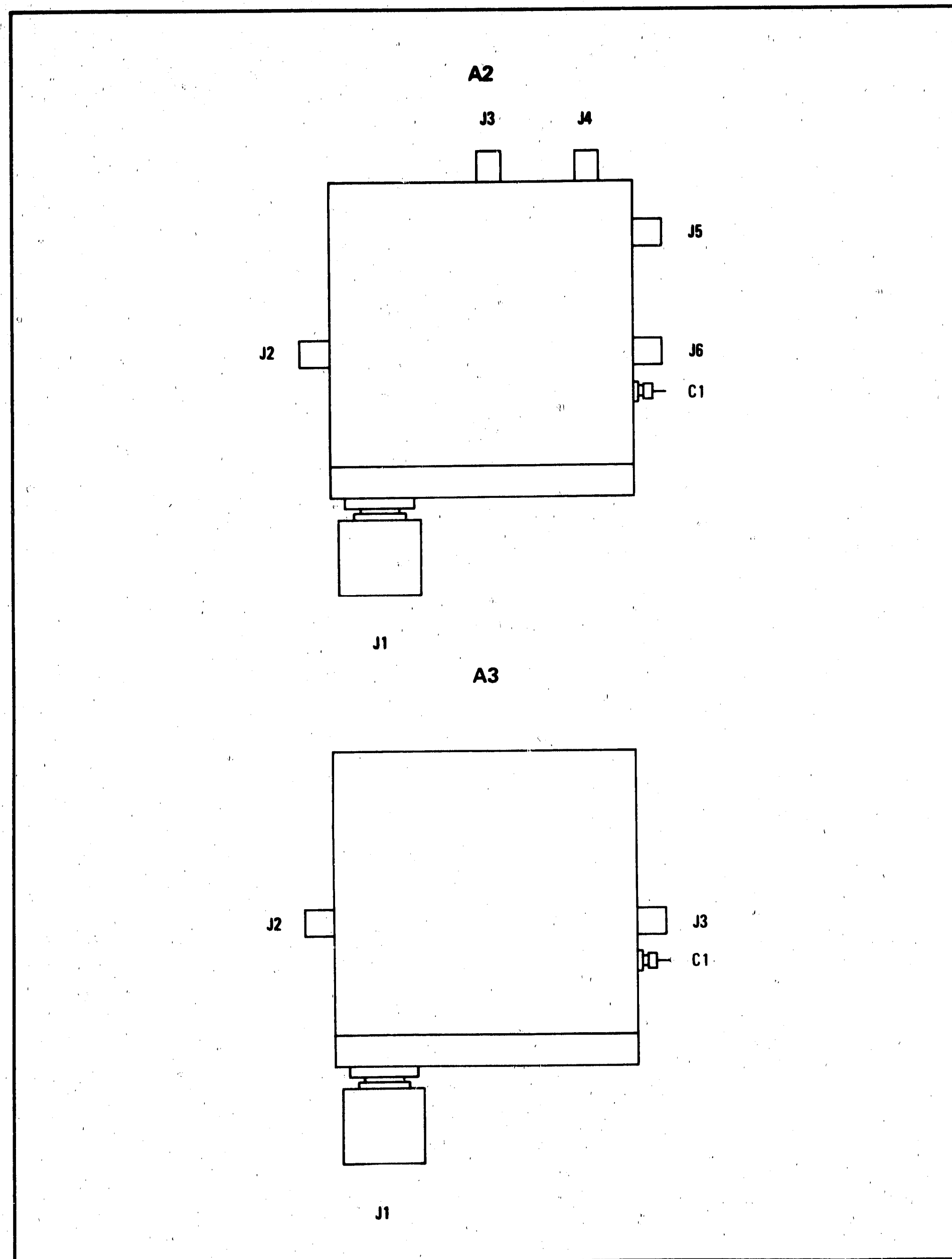

Figure 8-7. A2 Splitter/Directional Bridge and A3 Directional Bridge, Connector Locations

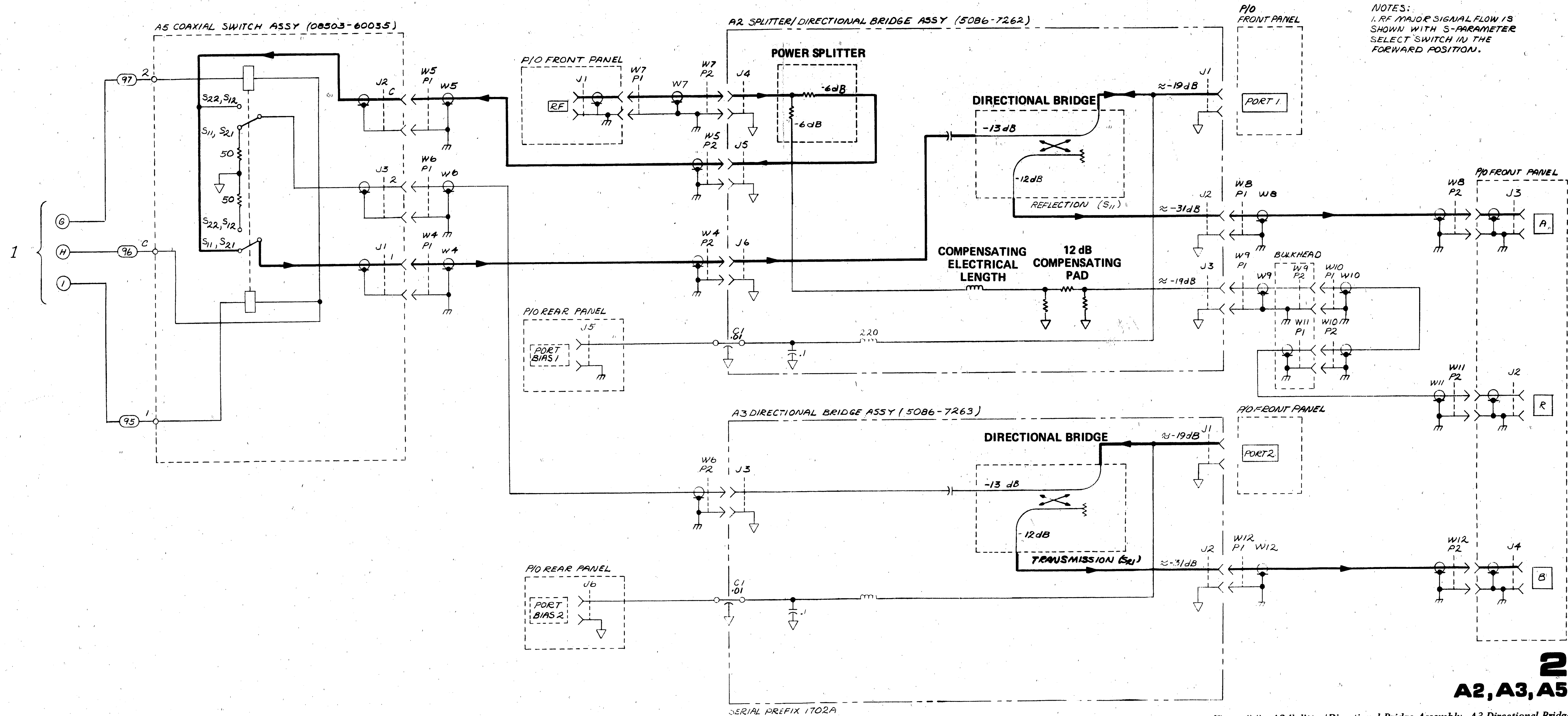

Figure 8-8. A2 Splitter/Directional Bridge Assembly, A3 Directional Bridge Assembly, and A5 Coaxial Switch Assembly, Schematic

2
A2, A3, A5

SERVICE SHEET 3

A8 HP-IB ASSEMBLY, CIRCUIT DESCRIPTION

General

The Hewlett-Packard Interface Bus (HP-IB) provides a means of communication between instruments. The bus provides two ways data flow over a single cable using standardized interface techniques. The interface design allows forming a system with only two instruments or up to fourteen instruments, and a controller (calculator or computer). The HP-IB uses sixteen signal lines to connect all units of a system in parallel. Eight of these lines carry data bits and three coordinate the flow of data. The remaining five are Bus management lines. Each device of an instrumentation system using the HP-IB follows a strict protocol that enables Bus operations to proceed in an orderly manner.

The 8503B Option 001 allows the 8503B S-Parameter Set to be remotely switched via the Hewlett-Packard Interface Bus. The HP-IB controller (calculator or computer) can also sense the position of the coaxial input switch while the 8503B is in local operation. The following is a description of how this is accomplished.

Bus Transceiver

The data and handshake signals of the HP-IB use logic "0" as TRUE and the logic "1" as FALSE. For use in the 8503B these signals are buffered and inverted by the bus transceivers.

The bus transceivers consist of U18 through U21. These quad-bus transceivers provide proper termination for the bus and invert the bus data received while the 8503B is in Listen Mode. Each transceiver drives and inverts data to HP-IB when in Talk Mode.

Handshake Logic

The Handshake Logic consists of U11A, U11D, U11E, U1B, U2D, U1C, U17B and U17C. Its operation is as follows:

Listen Mode. When the 8503B is on the HP-IB and addressed to listen, the handshake sequence is as follows:

The controller sets ATN low (U18-9). The resulting high at U1C-9 enables U18 to be a bus driver. A high at U11D-8 drives NDAC low (U18-2) and the low at U11E-10 drives NRFD high (U18-7). This condition tells the Controller the 8503B is ready and data is put on the data bus lines (D101 thru D107). When this data is stable, the controller sets DAV low (U19-9).

The falling edge of DAV (U19-9) is used to clock the data and other information into latches (discussed later). DAV going low will place a high at U11D-9 setting NDAC high (U18-2) and setting NRFD low (U18-7), which tells the controller that the data has been accepted and to remove it from the bus.

The controller responds to the NDAC line by setting DAV high (U19-9) and completing one handshake cycle.

Talk Mode. In the talk mode the 8503 will sense the NRFD and NDAC lines at U1B-6 and U2D-13. U19 is enabled as a bus driver by U17C-8 being low. When the controller/listener on the bus sets NDAC low and NRFD high, the output of U2D-11 will drive DAV low. The network of R4 and C9 will delay DAV long enough to allow the data on the data bus to settle. NRFD will then be pulled low and NDAC pulled high by the controller/listener. DAV (U19-9) will then go high allowing the process to be repeated until all data is transferred.

How the 8503B puts data on the bus will be discussed later.

Troubleshooting the Handshake Logic

If there is an 8503B handshake malfunction, the controller will wait indefinitely for either NRFD or NDAC valid. The 8503B handshake circuitry can be checked for proper operation without a controller in the following manner.

1. Disconnect the bus cable.
2. Ground the ATN line (Pin 11 of the HP-IB connector).
3. Apply approximately +5 volts to DAV line (Pin 6 of the HP-IB connector) either with a power supply or a 10526T logic pulser probe.)
4. Verify that NDAC (Pin 8 of HP-IB connector) is low (≈ 0 volts) when DAV is high ($\approx +5$ volts), and high when DAV is low.
5. Verify that NRFD (Pin 7 of HP-IB connector) is high ($\approx +5$ volts), and low when DAV is low.

Address Comparator

The Address Comparator consists of U1, a five-bit digital comparator, SW1, U2A, U2C and U12A. U14 will compare the data lines D101 through D105 with the setting of SW1 (see Section III, Figure 3-6 for instructions on setting SW1). When the two-five bit words agree, U14-14 will go high indicating "MY ADDRESS."

U2C and U12B are used to determine whether the address received is a talk or listen address and will compare D106 and D107. If D106 is high a listen address is present on the Data line. If D107 is high it is a talk address.

U2C receives D106 and pin 9 and the inverted D107 on pin 10. U2C-8 is then "ANDed" with "MY ADDRESS" at U2A to generate "MY LISTEN ADDRESS" (MLA) when D106 is high. U12B will "AND" D107, the inverted D106, and "MY ADDRESS" to form "MY TALK ADDRESS" (MTA) when D107 is high.

Remote Flip-Flop

Remote flip-flop (U16A) sets the 8503B into remote operation, energizes the front panel light, allows switching data to be latched into the 8503B; and disables the front panel switch.

The remote flip-flop is set in the following manner. The controller will address the 8503B to listen and pull REN Low (U19-15). The high REN at U2B-5 is "AND'ed" with the high MLA at U2B-4 which places a high at the J input of U16A (pin3). U10C-10 will pull the K input of U16B (Pin 2) low. With the ATN line low (U18-9) a high is present on U17A-1. When DAV is pulled low as discussed above, the negative-going edge of CMD CLK from U17A-3 will clock U16A. Pin 6 (LREM) will go low putting the 8503B in remote.

Listen Flip-Flop

Listen Flip-Flop U16B operates as follows:

MLA is applied to the J input, U16B-11. The low output of U17D is applied to the K input of U16B-12. When the CMD CLK line goes low as previously described, the flip-flop will set with U16B-9 high (LISTEN) and U16B-7 low. Before being clocked, U16B-7 was high. This high held the output of U10C low, ensuring that the remote flip-flop would not change state when the CMD CLK was generated.

Talk Flip-Flop

When the 8503B is addressed to talk, the MTA line will go low. This low is applied to U17D-13, which places a high on the K input of U16B (listen F-F) and on the D input of U9 pin 2. When the CMD CLK goes low, the listen and remote F-F are reset and U9-6 will go high enabling the TALK line. U13A will NAND D107, D106 and CMD CLK to form the positive-going clock signal for U9 (TALK FF).

Remote Programming of the Coaxial Switch Position

The remote programming feature may be thought of as a substitute for the front panel with information in a programmable latch. The front panel is controlled by LREM. A low causes the front panel data selector, A6U3, to be disabled and, at the same time, enables the output of the programmable latch, U5 pin 3.

Since the Decoder/Driver is connected to both the front panel and the programmable latch, whichever one is enabled will control the Coaxial Switch position.

To program the 8503B, a bi-directional data buffer is employed. It is divided into two major IC's, U8 and U5.

1. U8 serves as the "Data Direction Control."
2. U5 serves as the "Data Latch."

3. The Data Direction Control is a dual four-position analog switch. The switch position is controlled by two lines: "DATA VALID" (A) and "TALK" (B). Table 8-1 shows control codes, switch position, and resulting function.

Table 8-1. Data Direction Control Operation

	U8-9		Selector Conn	Result
	B	A		
Listen, Invalid Data	0	0	0 U5-3	D latch senses its own output U5-3 and relocks it into the latch upon data clk (DAV TRUE)
Listen, Data Valid	0	1	1 Data from bus applied to input of latch.	Bus data available for loading into latch.
Talk, Don't care about input data being valid or invalid.	1	0	2 S-Parameter Select switch position is sensed through resistor.	S-Parameter Select switch position is "LEARNED" thru sense resistor R3, buffered by U15E and U15D and applied to encoder.
	1	1	3 select switch position is sensed through resistor.	

Remote programming of the Coaxial Switch position is accomplished if:

1. Interface is in remote (LREM U16A-6 low).
2. Interface LISTEN FF is set (U16B-9 high).
3. Valid data code on data bus (U8-10 high).
4. "DATA" on bus is not a CMD code (ATN U10B-6 high).

The codes accepted by the valid data detector are, for Port 1, ASCII "1" or "3", and for Port 2, ASCII "2" or "0."

The data is loaded by the edge of DAV going TRUE (U19-9 low).

Remote Sensing of the Front-Panel S-PARAMETER SELECT Switch Position and Interface "TALK" Mode:

Remote sensing is accomplished when 8503B interface encodes the front panel S-PARAMETER SELECT switch position and sends appropriate bytes to the controller.

The encoding of data is performed by U22, U1C, U11F and U3 (Data Sequencer and Encoder).

The codes, in the order sent, are given in Table 8-2:

Table 8-2. 8503B HP-IB Output Data

Output Data	Octal	Binary
Front Panel Data	061 or 062*	1100XX
Carriage Return (CR)	015	001101
Line Feed (LF)	012	001010
* 061 = Port 1 062 = Port 2		

The circuit operation may be understood if it is realized that U3, a presettable counter, is serving a dual purpose: it not only sequences the sending of the codes, but its outputs are also part of the codes.

Thus, the two least significant bits (LSB) of the counter drive U22. The outputs of U22 drive DIO 1 and 2. The same two LSB's are gated by U1C and U11F to generate the codes for DIO3, 4, 5, and 6.

A summary of the codes generated or controlled by the two LSB's of counter U3 are given in Table 8-3.

Table 8-3. Summary of Codes Generated by Data Sequencer and Encoder

Source	U22 Input		U22 Outputs (DIO)		U3 Outputs (DIO)			Information
	U22-2	U22-14	1	2	3	4	5	
	0	1	0 or 1	1 or 0	0	0	1	Front Panel Data
	1	0	1	0	1	1	0	Carriage Return
	1	1	0	1	0	1	0	Line Feed
	Two LSB of U3 Counter Output		Gen. by U22, (MUX)		Gen. by U1D, U11E			

A2 Splitter/Directional Bridge Assembly
A3 Directional Bridge Assembly
A5 Coaxial Switch Assembly
SERVICE SHEET 2

The actual transfer of the front panel "LEARNED" information is done with the three-wire handshake, but with the 8503B acting as the "TALKER".

The transfer is enabled if the interface has been addressed to talk (FF U9 pin 6 high) and if ATN is false (ATN high, U18-9). Note that the counter, U3, is preset to 0001 by ATN going true. This is done to ensure that each time the 8503B interface is addressed to talk (ATN goes low), the talk sequence begins at the same point, namely, data first.

The talk handshake is enabled and terminated by the QC bit of counter U3.

There are actually three "handshakes." Each time the listener accepts a data byte, DAC (U3 pin 5) will go low then high clocking the counter.

After the third high-going DAC (U3-5), the QC counter bit will go high, disabling U1B and inhibiting any further handshaking by pulling DAV high (U19-9).

Troubleshooting the Data Sequences and Encoder

The operation of the Data Sequencer and Encoder may be verified without the use of the controller in the following manner.

1. Ground U17C-8 (or clock U9-3 Talk FF with a logic pulser probe leaving ATN U18-9 floating).
2. With +5 volt power supply or logic pulser probe, apply a momentary logic high to NDAV line (pin 8 of rear-panel HP-IB connector, or U18-2).
3. With a scope, voltmeter, or logic probe, verify the logic levels on DIO 1 through DIO 6. See Table 8-3 for correct levels. (If levels are checked at HP-IB connector, they will be the inverse of those in Table 8-3.)
4. Repeat steps 2 and 3 until U3-6 goes high (three clock pulses of NDAC line). Then verify that the handshake DAV goes high at HP-IB connector pin 6 or U19-9.

Set to Local and Power-Up Clear

The Interface State Memory (Listen FF, Remote FF, Talk FF) can be cleared by any of the following means.

1. At Power turn-on, R1 and C8 form a time delay to hold U15A-3 low momentarily. The resulting high at u15A-2, pulls U10A-1 and U10D-13 low, resetting the Interface State Memory.
2. A front panel LOCAL reset pushbutton on the 8503B may be depressed to place a low at U15A-3 and initiate the above sequence.
3. The Listen and Talk flip-flops can be cleared by the controller sending an Interface Clear (IFC), U18-15 low. The resulting high at U18-14 is applied to U10A-2.
4. The Remote FF can be cleared by the controller sending a REN FALSE (high at U19-15). The logic at U19-14 is applied to U11A-1, inverted and sent to U10D-11 to reset the Remote FF.

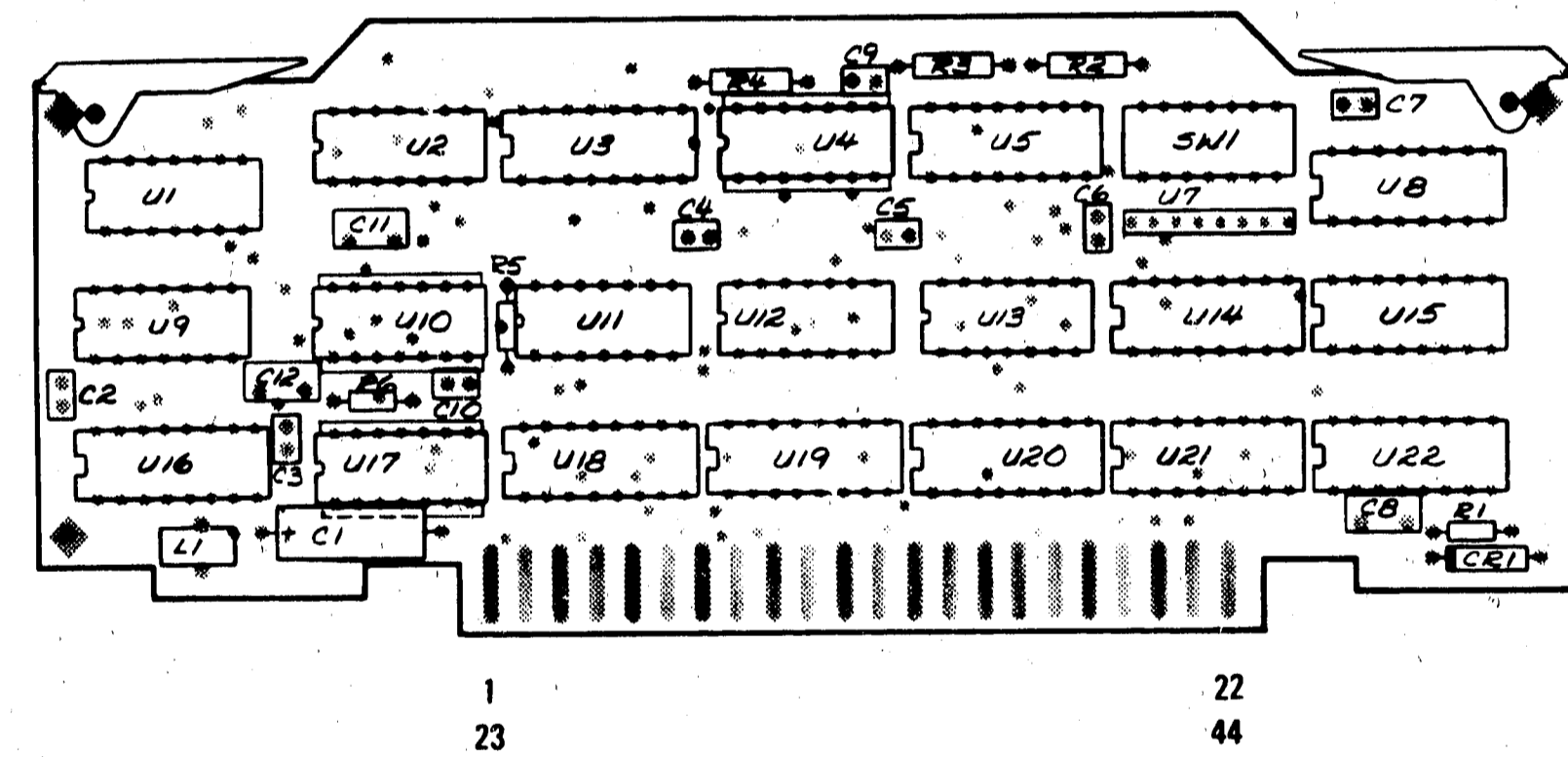

Figure 8-9. A8 HP-IB Assembly, Component Locations

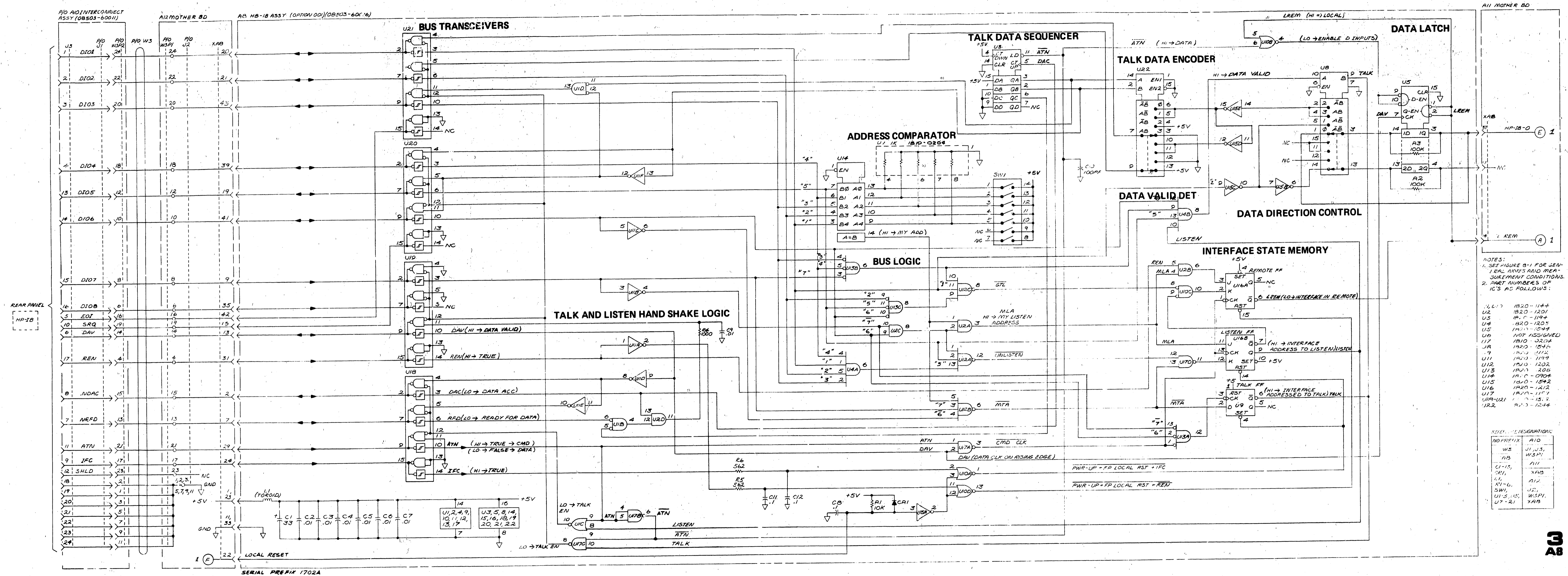

Figure 8-10 A8 HP-IB Assembly, Schematic

SERVICE SHEET 4**A4 POWER SUPPLY ASSEMBLY, CIRCUIT DESCRIPTION****General**

The Power Supply assembly provides the 8503B with two regulated voltages, +5 volts and +24 volts. Both of these supplies are fused on assembly A4. If only one of the supply voltages is present, check the fuse for the other supply before further troubleshooting. If both of the supply voltages are not present, check the line fuse in the rear-panel Line Module. U1 and U2 are three-terminal IC's in a TO-3 package. They are both internally provided with current limiting and thermal overload protection.

+ 5 Vdc Supply

The output of full-wave bridge rectifier U4 is 8.9 Vdc to 15 Vdc. This dc voltage is applied to pin 1 of voltage regulator U1, which provides a +5 Vdc regulated output. Capacitor C1 provides filtering and C2 is a bypass for switching transients. Capacitor C3 provides stability for voltage regulator U1.

+ 24 Vdc Supply

The output of full-wave bridge rectifier U3 is 27 Vdc to 41 Vdc. This dc voltage is applied to pin 1 of voltage regulator U2 and divider network R1-R2. Integrated circuit U2 is a 15-volt regulator. Since +24V is required, breakdown diode VR1 is placed effectively in series with the regulated +15 volts to provide the +24 volt regulated output. Resistor network R1-R2 provides the proper voltage to pin 3 of U2. Resistor R2 also provides a current sink for U2 so it will continue to conduct when high switching currents are drawn. Capacitor C6 provides filtering and C7 is a bypass for switching transients. Capacitor C8 provides stability for voltage regulator U2 and C9 helps provide switching current during the nulls of the full-wave rectified (U3) output.

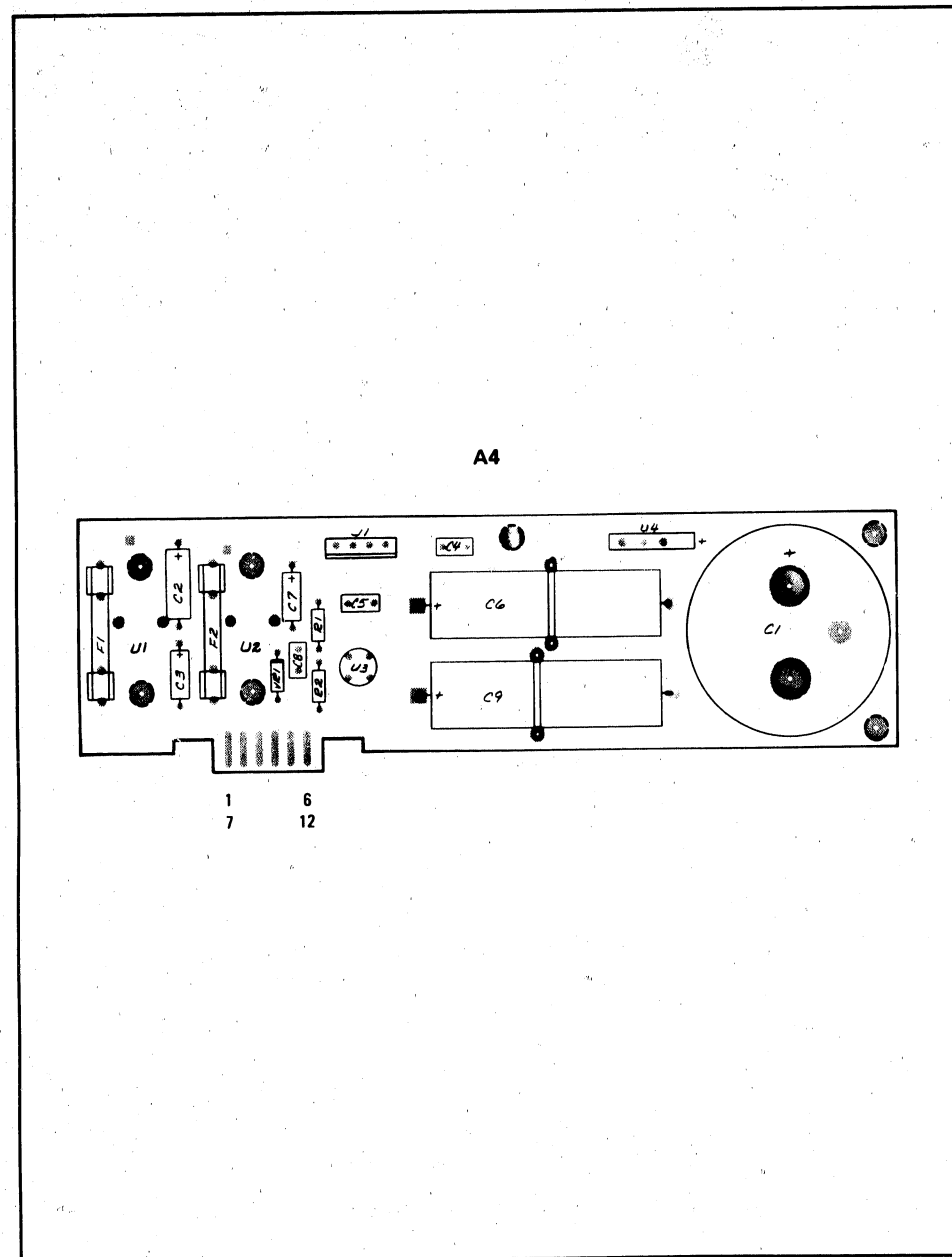
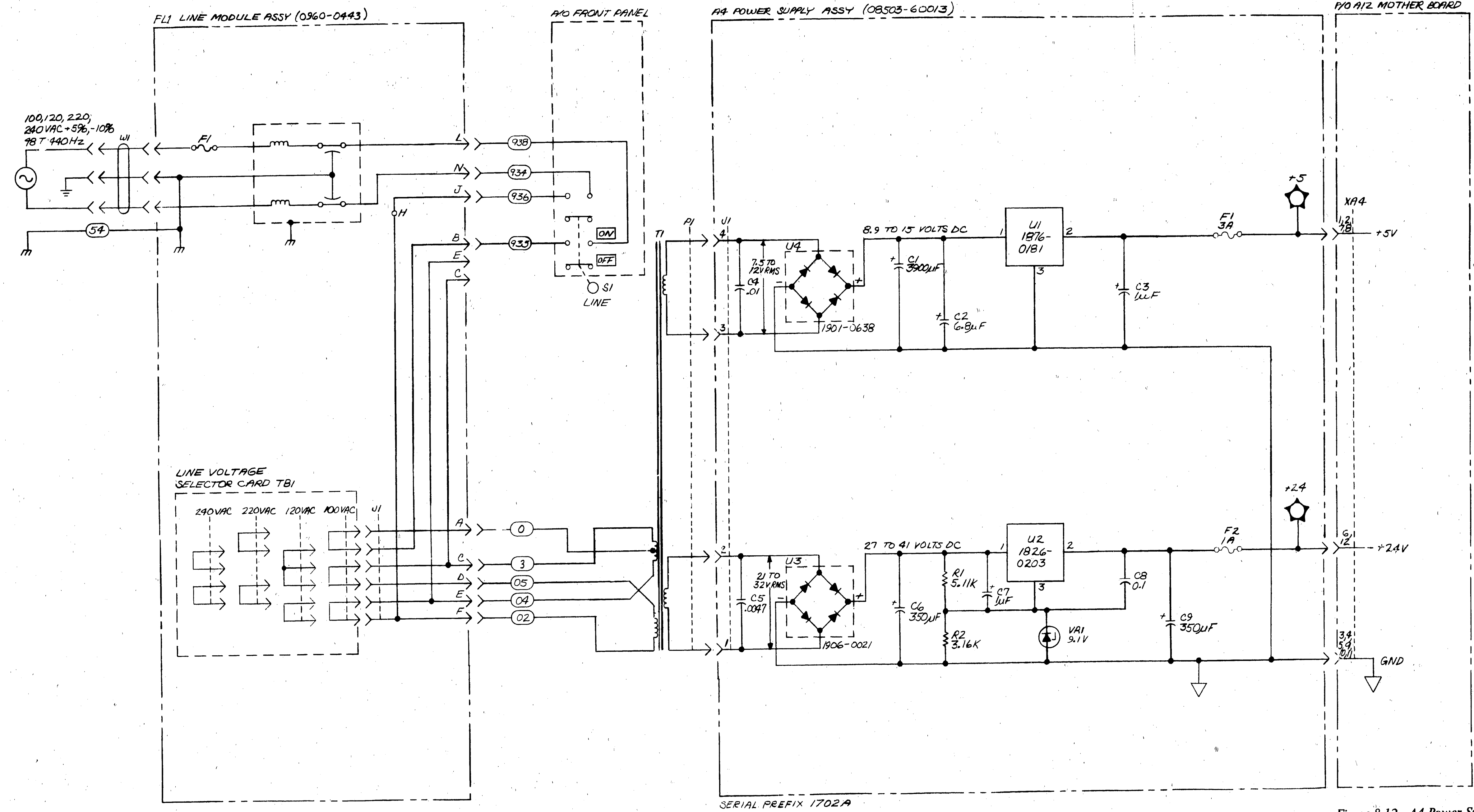

Figure 8-11. A4 Power Supply Assembly, Component Locations



SERIAL PREFIX 1702A

REFERENCE DESIGNATIONS

NO PREFIX	A4
FL1	F1, F2
FL1/U1	U1
R1, R2	U1-4
U1	U1-4
S1	VR1
T1	A12
	XA4

Figure 8-12. A4 Power Supply Assembly, Schematic
8-15/8-16

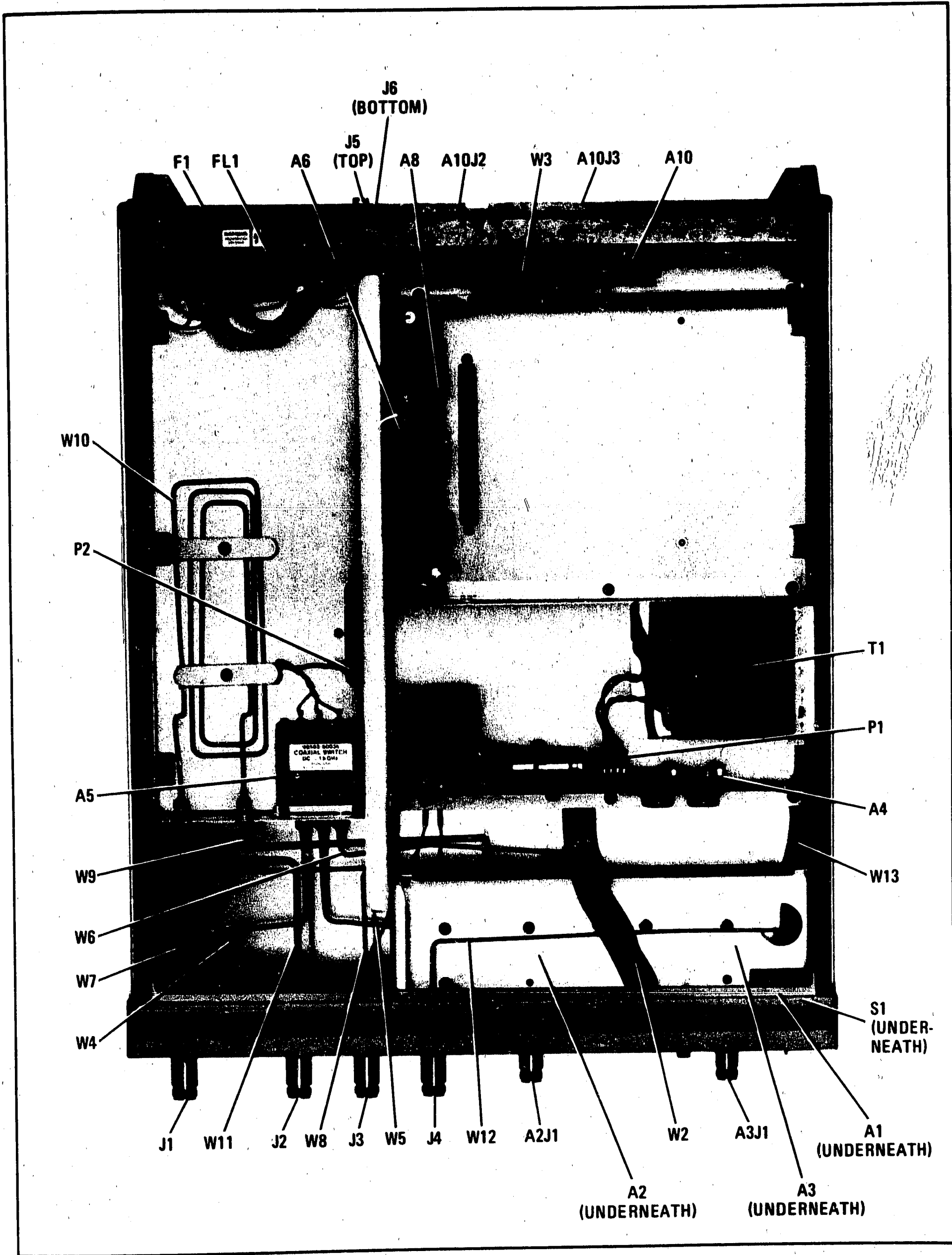

Figure 8-13. 8503B Major Assemblies, Cables, and Connector Locations

MANUAL CHANGES

MANUAL CHANGES

MANUAL IDENTIFICATION

Model Number: 8503B

Date Printed: March 1977

Part Number: 08503-90004

This supplement contains important information for correcting manual errors and for adapting the manual to instruments containing improvements made after the printing of the manual.

To use this supplement, make all ERRATA corrections and all appropriate serial number related changes indicated in the tables below.

SERIAL PREFIX OR NUMBER	MAKE MANUAL CHANGES
1702A113, 114, 118, 119, 120, 127, 129; 1802A Prefix	1
1851A	1, 2
1942A	1, 2, 3
1951A	1, 2, 3, 4
2016A	1-5
2105A	1-6
2142A	1-7

SERIAL PREFIX OR NUMBER	MAKE MANUAL CHANGES
2432A	1-8
2515A	1-9

▶ NEW ITEM

ERRATA

Page 1-0, Figure 1-1:

Add Extender Bd., HP Part Number 08503-60044 (No Photo).

Delete individual part numbers on LOCK FEET and VERTICAL LOCK LINKS and put them all under one part number, HP 5061-9699, REAR PANEL LOCK FEET KIT.

Change the SIGNAL PROCESSOR INTERCONNECT CABLE to HP Part Number 08503-60051.

▶ Change the RF Connecting Cables to HP Part Number 8120-4782.

Change the HP-IB Interconnect Cable to Part Number 8120-3444 and delete "Option 001 Only)."

NOTE

Manual change supplements are revised as often as necessary to keep manuals as current and accurate as possible. Hewlett-Packard recommends that you periodically request the latest edition of this supplement. Free copies are available from all HP offices. When requesting copies, quote the manual identification information from your supplement, or the model number and print date from the title page of the manual.

Printed in U.S.A.

28 APRIL 1986

20 pages



**HEWLETT
PACKARD**

ERRATA (Cont'd)

Page 1-2, under **WARNINGS**:

Change the fifth paragraph to read as follows:

If this product is to be energized via an autotransformer make sure the common terminal is connected to the neutral (grounded side of mains supply).

Page 1-4:

Delete Paragraph 1-23, 1-24, and all other references to Option 001 in the manual. Substitute the words "HP-IB" in place of "Option 001."

Page 1-4, Paragraph 1-25:

Change this paragraph to: **Attaching Front Handles**

Page 1-4, Paragraph 1-26:

Change this paragraph to: Each HP 8503B is shipped without front handles attached. A Front Handles Kit is supplied as a standard feature with each HP 8503B. It used to be Option 907. Replacement, or additional Front Handles Kits may be ordered as HP Part Number 5061-9688. See Figure 2-5 (Option 913), for installation of the Front Handles Kit.

Page 1-4, Paragraph 1-28:

Change this paragraph to: Option 908, HP Part Number 5061-9676, contains flanges and hardware required to mount the HP 8503B in an equipment rack with 482.6 mm (19 inches) horizontal spacing. See Figure 2-5 for installation instructions.

Page 1-4, Paragraph 1-29:

Change this paragraph to: **Option 913 Rack Flange/Front Handle Kit.**

Page 1-4, Paragraph 1-30:

Change this paragraph to: Option 913, HP Part Number 5061-9769, supplies rack mounting flanges and the necessary hardware for mounting the flanges on instruments with existing handles. The existing handles need to be removed before installing the rack mount flanges under the handles. See Figure 2-5 for installation instructions.

Page 1-5, Paragraph 1-34:

Replace Paragraph 1-34 with the following text: "Figure 1-1 shows the HP Model 8503B S-Parameter Test Set, line power cable, Signal Processor interconnect cable, HP-IB interconnect cable, four 19 cm (7½ inch) RF connecting cables, and one extender board.

Page 2-3, Paragraph 2-13:

Change Paragraph 2-13 to read: "**2-13. HP-IB Cable.** Connect HP-IB cable (HP Part Number 8120-3444 from the HP 8503B rear-panel HP-IB connector (A10J3) to the HP 8505A rear-panel HP-IB connector." The HP-IB shorthand interface function codes for the HP 8503B are: SH1, AH1, T8, L4, SR0, RL2, PP0, DC0, DT0, C0, E1.

Page 2-3, Table 2-1:

Change A10J3 HP-IB to HP Part Number 8120-3444, 8120-3445, 8120-3446 and 8120-3447.*

Replace the footnote at the bottom of Table 2-7 with the following footnote:

HP-IB cable 8120-3444 is approximately 0.5 meter long; 8120-3445, 1 meter long; 8120-3446, 2 meters long, and 8120-3447, 4 meters long.

Page 2-5, Paragraph 2-22:

Change the paragraph to: **Locking Units Together.** If it is desired to lock the HP 8503B and the HP 8505A together, use the Rear Panel Lock Feet Kit (supplied), HP Part Number 5061-9699. The Rear Panel Lock Feet Kit contains the vertical lock links which connect the front frames of the two instruments together. HP 8503B Test Sets having Serial Number 2513A01686 or above have front frames with Metric screw holes. Check the Serial Number of the HP 8503B and use the proper screws (Inch or Metric) to secure the lock links to the HP 8503B front frame. Both types of screws are supplied with the Rear Panel Lock Feet Kit.

ERRATA (Cont'd)**Page 2-5, Paragraph 2-22b:**

Change the paragraph to: Fasten the four lock links (Part of HP Part Number 5061-9699) to the HP 8503B front frame using the eight Inch or Metric screws provided. There are eight threaded holes in the front frame for this purpose. The hook-shaped protrusions of the lock links must extend toward the rear of the HP 8503B.

Page 2-5, Paragraphs 2-22c through 2-22e:

Delete all mention of HP Part Numbers in these paragraphs.

Page 2-6, Paragraph 2-25:

Change the paragraph to: **Rack Mounting (Options 908 and 913)**

Page 2-6, Paragraph 2-27:

Change the first sentence to: Instruments with Option 913 contain the Rack Flange Front Handle Kit.

Page 2-6, Paragraph 2-28:

Delete mention of Option 907. The Front Handle Kit is standard.

Page 2-6, Paragraph 2-29:

Delete the first sentence.

Page 2-6, Table 2-2:

Replace the table with Table 2-2 (ERRATA) supplied in this Change Sheet.

Page 2-9, Figure 2-5:

Replace the figure with Figure 2-5 (ERRATA) supplied in this Change Sheet.

Page 3-2, Figure 3-1:

On the REAR view, change callout 14 to 15 (Port Bias 2 BNC Connector), and callout 15 to 14 (Port Bias 1 BNC Connector).

Page 4-21, Performance Tests:

Change test heading 4-12 to read: **"PORT MATCH - TEST PORTS 1 and 2."**

For test 4-12 DESCRIPTION:

Change the first sentence to read: "Perform the Directivity (Incoming Inspection Test, Figure 2-6) and the Test Port Open/Short Ratio Test (Paragraph 4-11)."

Page 4-23, Paragraph 4-13:

In the equipment list for Figure 4-11, change the eighth item description as follows: "Termination, 75 ohm, Type N Female."

Page 6-4, Table 6-2:

Add the following caution after the description of A2J1.

CAUTION

The A2J1 connector is not meant to be customer-repairable as it is part of the A2 splitter/directional bridge assembly. Damage to the splitter/directional bridge is likely to result should this connector be disassembled.

Add the following caution after the description of A3J1.

CAUTION

The A3J1 connector is not meant to be customer-repairable as it is part of the A3 directional bridge assembly. Damage to the directional bridge is likely to result should this connector be disassembled.

ERRATA (Cont'd)**Page 6-6, Table 6-2:**

Add the following statement after the description of chassis part F1 having HP Part Number 2110-0004: "One fuse only is supplied. The type of fuse supplied depends upon the nominal line distribution voltage of country of destination."

Page 6-7, Table 6-2:

Under MISCELLANEOUS heading, change CABLE HP-IB INTERCONN to HP Part Number 8120-3444.

Under MISCELLANEOUS heading, add HP Part Number 7121-2527, CD 5, METRIC AND INCH CAUTION LABEL.

Page 6-8, Figure 6-2:

Change the exploded view title to **A2J1/A3J1**.

In the table, change Reference Designation 3 to HP Part Number 5021-1746.

Page 6-10, Figure 6-3:

Delete Reference Designation 7.

Change the following HP Part Numbers in the table.

Reference Designation	HP Part Number
1	5021-5801
2	5021-5802
8	5041-6819
9	5041-6820
14	5021-5832
15	5061-9435
16	5061-9447

CHANGE 1**Page 6-5, Table 6-2:**

Delete A8C9 and A8R4.

Add A8C13, HP Part Number 0160-3878, CAPACITOR-FXD, 1000 PF $\pm 20\%$ 100 VDC CER.

Add A8CR2, HP Part Number 1902-0539, DIODE-SCHOTTKY.

Add A8R7, HP Part Number 0698-7236, RESISTOR 1K 1% .05W F TC = 0 ± 100 .

Page 8-13, Figure 8-9:

Replace Component Location drawing with the drawing of A8 included in this Change Sheet.

CHANGE 1 (Cont'd)

A8

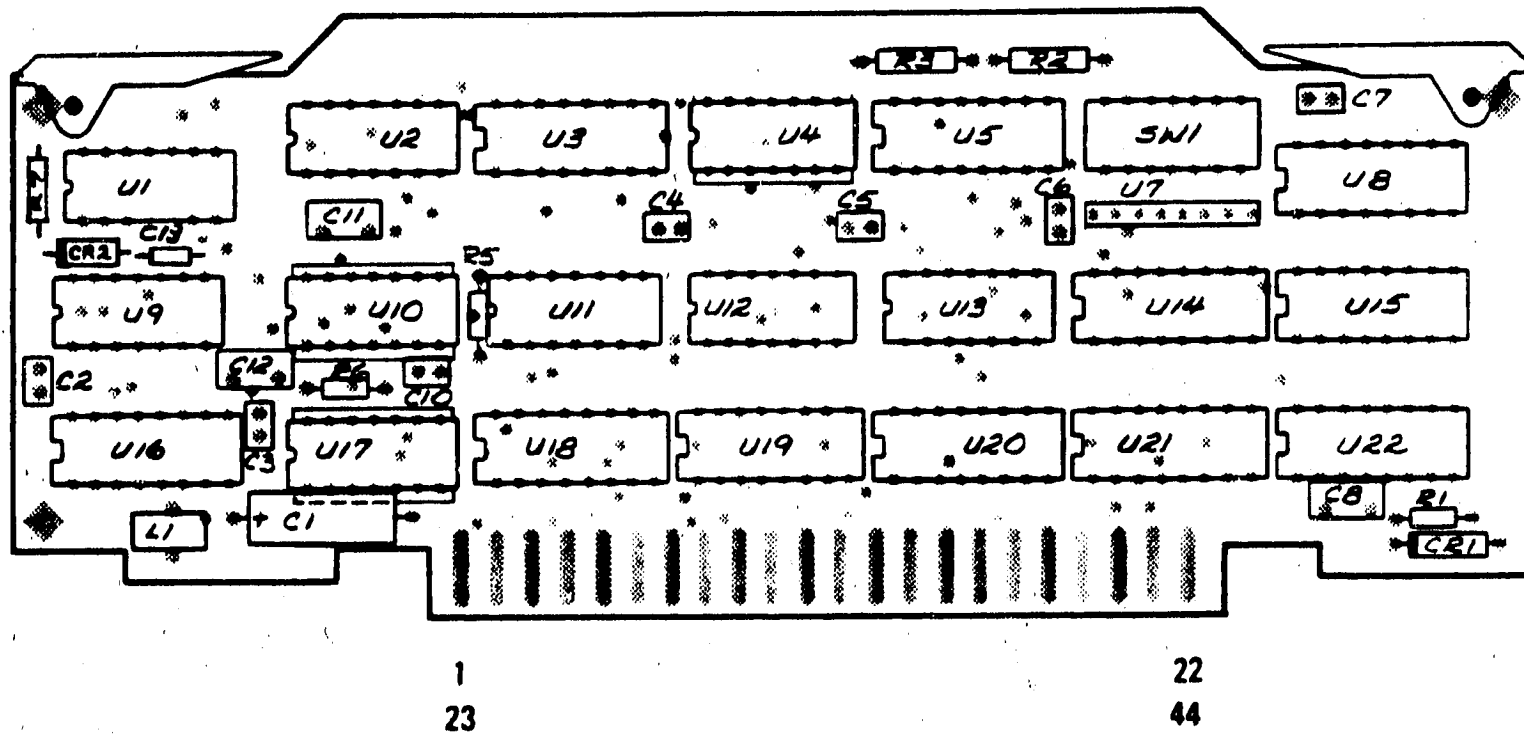

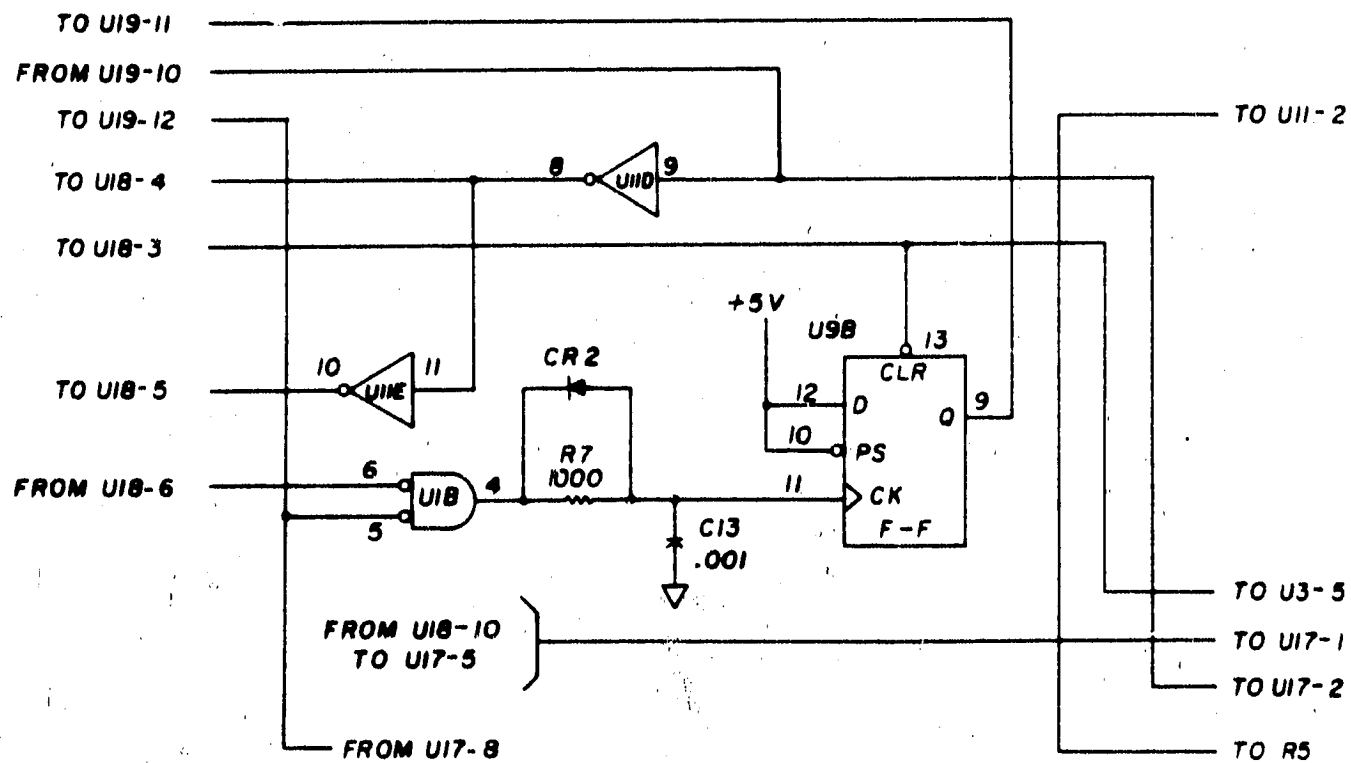

Figure 8-9. A8 HP-1E Assembly, Component Locations (Change 1)

Page 8-13, Figure 8-10:

Add a chassis ground wire () that goes into A10 Interconnect Assembly and connects to J3-12 (SHLD).

Add C13, CR2, and R7; delete C9 and R4; disconnect U2D; and connect U9B as shown in the partial schematic following:



P/O Figure 8-10 (Change 1)

CHANGE 2

Page 1-0, Figure 1-1:

Change the part number under Signal Processor Interconnect Cable to 08503-60051.

Page 2-3, Paragraph 2-12:

Change part number of Signal Processor Interconnect Cable to HP Part Number 08503-60051.

Page 6-7, Table 6-2:

Change HP Part Number 08503-60005 to 08503-60051 for SIG. PROC. INTERCONN. CABLE.

CHANGE 3

Page 6-10, Figure 6-3:

Change Reference Designator 19 to HP Part Number 08503-00027.

Page 6-12, Figure 6-4:

Change Reference Designator 15 to HP Part Number 08503-00025.

Change Reference Designator 16 to HP Part Number 08503-20007.

CHANGE 4

Page 6-4, Table 6-2:

Change A4 to HP Part Number 08503-60048.

Add A4CR1 through A4CR4, HP Part Number 1901-0662, DIODE-POWER 100V 6A.

Change A4U3 to HP Part Number 1906-0094.

Delete A4U4.

Page 8-15, Figure 8-11:

Replace existing Figure 8-11 with the one included in this change sheet (Change 4)

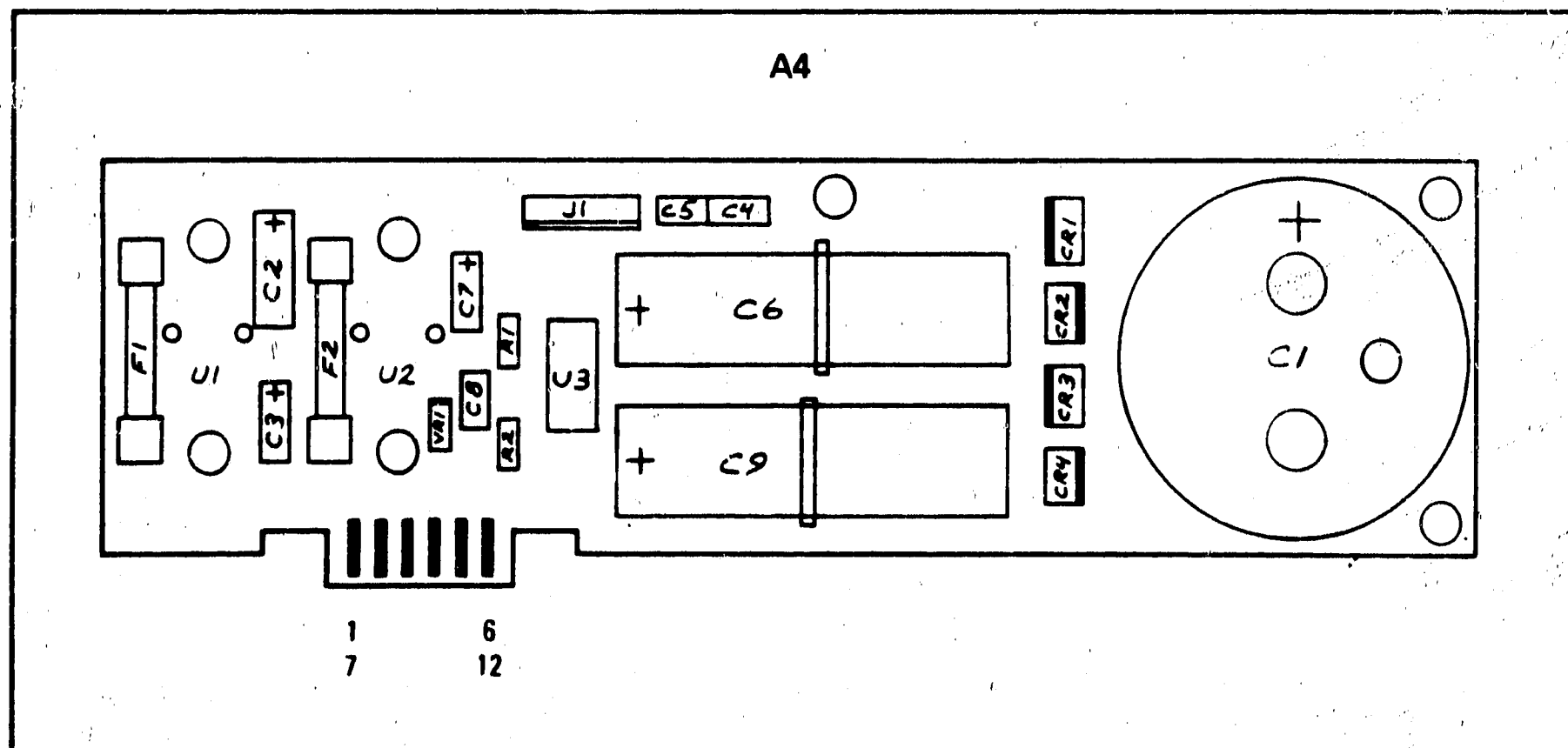
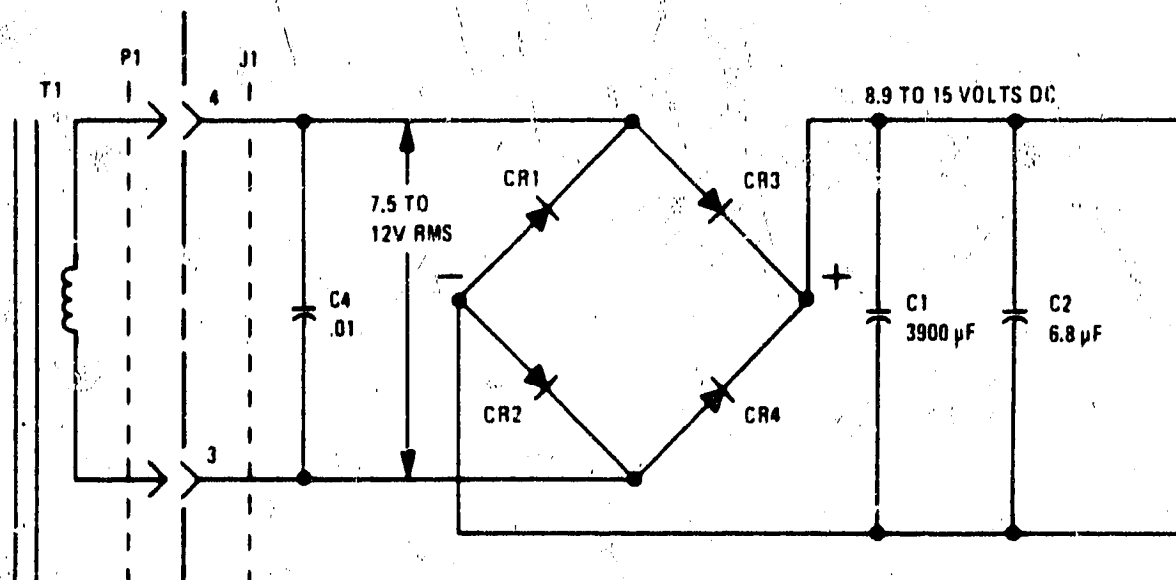

Figure 8-11. A4 Power Supply Assembly, Component Locations (CHANGE 4)

CHANGE 4 (Cont'd)

Page 8-15, Figure 8-12:

Change A4U4 to four diodes, A4CR1-CR4 as shown in the following partial schematic:



P/O Figure 8-12. A4 Power Supply (CHANGE 4)

CHANGE 5

No manual change.

CHANGE 6

Page 6-10, Figure 6-3:

Change item 19 to HP Part Number 08503-00030, CD 6.

Change item 20 to HP Part Number 08503-00028, CD 2.

CHANGE 7

Page 6-10, Figure 6-3:

Change item 19 to HP Part Number 08503-00031, CD 7.

Add item 22. HP Part Number 2420-0001, Qty 3, HEX NUT 6-32, CD 5.

CHANGE 8

Page 6-6, Table 6-2:

Change A12 to HP Part Number 08503-60050, CD 6.

Add A12C1 and A12C2, both having HP Part Number 0160-4833, CD 5, CAPACITOR—FXD .022UF $\pm 10\%$ 100VDC CER.

Add A12R1 and A12R2, both having HP Part Number 0757-0394, CD 0, RESISTOR 51.1 1% .125W F TC=0 \pm 100.
Under CHASSIS PARTS, add F2 and F3, both having HP Part Number 2110-0424, CD 9, FUSE .75A 125V NTD .25X.27.

Page 6-7, Table 6-2:

Under MISCELLANEOUS, add the following components:

1400-0110, CD 4, QTY 2, FUSEHOLDER-BIPIN SKT 5A 125V.

1400-0111, CD 5, QTY 2, FUSEHOLDER NUT FOR USE WITH HP PART NUMBER 1400-0110.

1400-0112, CD 6, QTY 2, FUSEHOLDER CAP FOR USE WITH HP PART NUMBER 1400-0110.

Page 6-10, Figure 6-3:

Change Reference Designation 21 to HP Part Number 08503-00033, CD 9.

Page 8-11, Figure 8-8:

Place the partial Figure 8-8 in this change sheet onto the existing Figure 8-8 Schematic.

CHANGE 9

Page 1-0, Figure 1-1:

Delete individual part numbers on LOCK FEET and VERTICAL LOCK LINKS and put them all under HP Part Number 5061-9699, REAR PANEL LOCK FEET KIT.

Page 1-4, Paragraph 1-25:

Change this paragraph to: **Attaching Front Handles**

Page 1-4, Paragraph 1-26:

Change this paragraph to: Each HP 8503B is shipped without front handles attached. A Front Handles Kit is supplied as a standard feature with each HP 8503B. It used to be Option 907. Replacement, or additional Front Handles Kits may be ordered as HP Part Number 5061-9688. See Figure 2-5 (Option 913), for installation of the Front Handles Kit.

Page 1-4, Paragraph 1-28:

Change this paragraph to: Option 908, HP Part Number 5061-9676, contains flanges and hardware required to mount the HP 8503B in an equipment rack with 482.6 mm (19 inches) horizontal spacing. See Figure 2-5 for installation instructions.

Page 1-4, Paragraph 1-29:

Change this paragraph to: **Option 913 Rack Flange/Front Handle Kit.**

Page 1-4, Paragraph 1-30:

Change this paragraph to: Option 913, HP Part Number 5061-9769, supplies rack mounting flanges and the necessary hardware for mounting the flanges on instruments with existing handles. The existing handles need to be removed before installing the rack mount flanges under the handles. See Figure 2-5 for installation instructions.

Page 2-5, Paragraph 2-22:

Change the paragraph to: **Locking Units Together.** If it is desired to lock the HP 8503B and the HP 8505A together, use the Rear Panel Lock Feet Kit (supplied), HP Part Number 5061-9699. The Rear Panel Lock Feet Kit contains the vertical lock links which connect the front frames of the two instruments together. HP 8503B Test Sets having Serial Number 2513A01686 or above have front frames with Metric screw holes. Check the Serial Number of the HP 8503B and use the proper screws (Inch or Metric) to secure the lock links to the HP 8503B front frame. Both types of screws are supplied with the Rear Panel Lock Feet Kit.

CHANGE 9 (Cont'd)

Page 2-5, Paragraph 2-22b:

Change the paragraph to: Fasten the four lock links (Part of HP Part Number 5061-9699) to the HP 8503B front frame using the eight Inch or Metric screws provided. There are eight threaded holes in the front frame for this purpose. The hook-shaped protrusions of the lock links must extend toward the rear of the HP 8503B.

Page 2-5, Paragraphs 2-22c through 2-22e:

Delete all mention of HP Part Numbers in these paragraphs.

Page 2-6, Paragraph 2-25:

Change the paragraph to: **Rack Mounting (Options 908 and 913)**

Page 2-6, Paragraph 2-27:

Change the first sentence to: Instruments with Option 913 contain the Rack Flange Front Handle Kit.

Page 2-6, Paragraph 2-28:

Delete mention of Option 907. The Front Handle Kit is standard.

Page 2-6, Paragraph 2-29:

Delete the first sentence.

Page 2-6, Table 2-2:

Replace the table with Table 2-2 (CHANGE 9) supplied in this Change Sheet.

Page 2-9, Figure 2-5:

Replace the figure with Figure 2-5 (CHANGE 9) supplied in this Change Sheet.

Page 6-7, Table 6-2:

Under MISCELLANEOUS, add HP Part Number 7121-2527, CD 5, METRIC AND INCH CAUTION LABEL.

Page 6-10, Figure 6-3:

Change the following HP Part Numbers in the table.

Reference Designation	HP Part Number
1	5021-5801
2	5021-5802
8	5041-6819
9	5041-6820
14	5021-5832
15	5061-9435
16	5061-9447

Table 2-2. Rack Mounting Kits for 8503B (ERRATA)

Description	HP Part Number	Quantity
OPTION 908		
Rack Flange	5020-8861	2
Machine Screw, Pan Head, 8-32 × 0.375 inch	2510-0193	6
M4 × 0.7 × 10 Pan Head	0515-1114	6
OPTION 915		
Handle Assembly	5060-9898	2
Rack Flange	5020-8935	2
Machine Screw, Pan Head, 8-32 × 0.625 inch	2510-0194	6
M4 × 0.7 × 16 Pan Head	0515-1106	6

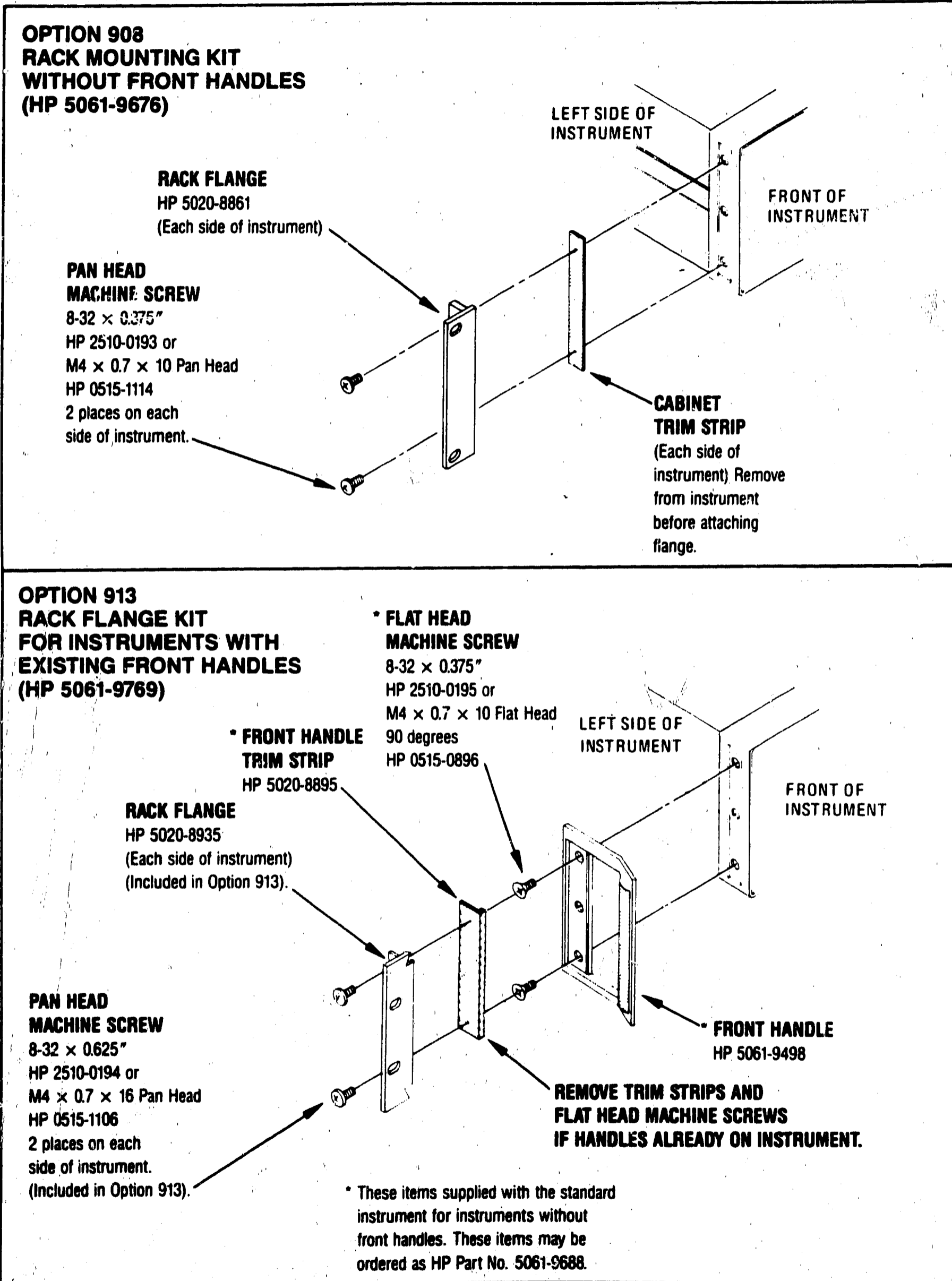
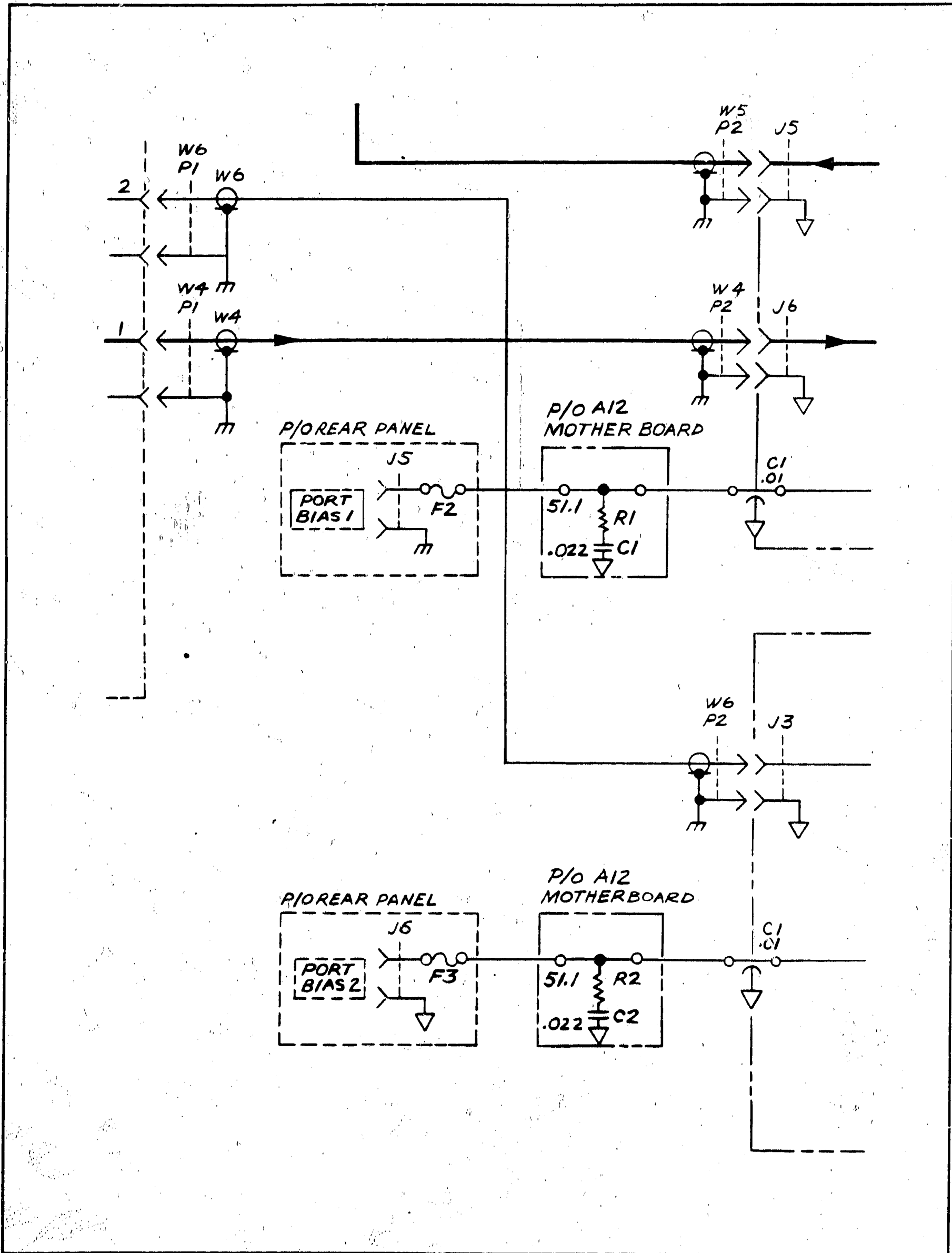

Figure 2-5. Attached Rack Mounting Hardware and Handles (ERRATA)



P/O Figure 8-8. A2 Splitter/Directional Bridge Assembly, A3 Directional Bridge Assembly, and A5 Coaxial Switch Assembly, Schematic (CHANGE 8)

Table 2-2. Rack Mounting Kits for 8503B (CHANGE 9)

Description	HP Part Number	Quantity
OPTION 908		
Rack Flange	5020-8861	2
Machine Screw, Pan Head, 8-32 × 0.375 inch	2510-0193	6
M4 × 0.7 × 10 Pan Head	0515-1114	6
OPTION 913		
Handle Assembly	5060-9898	2
Rack Flange	5020-8935	2
Machine Screw, Pan Head, 8-32 × 0.625 inch	2510-0194	6
M4 × 0.7 × 16 Pan Head	0515-1106	6

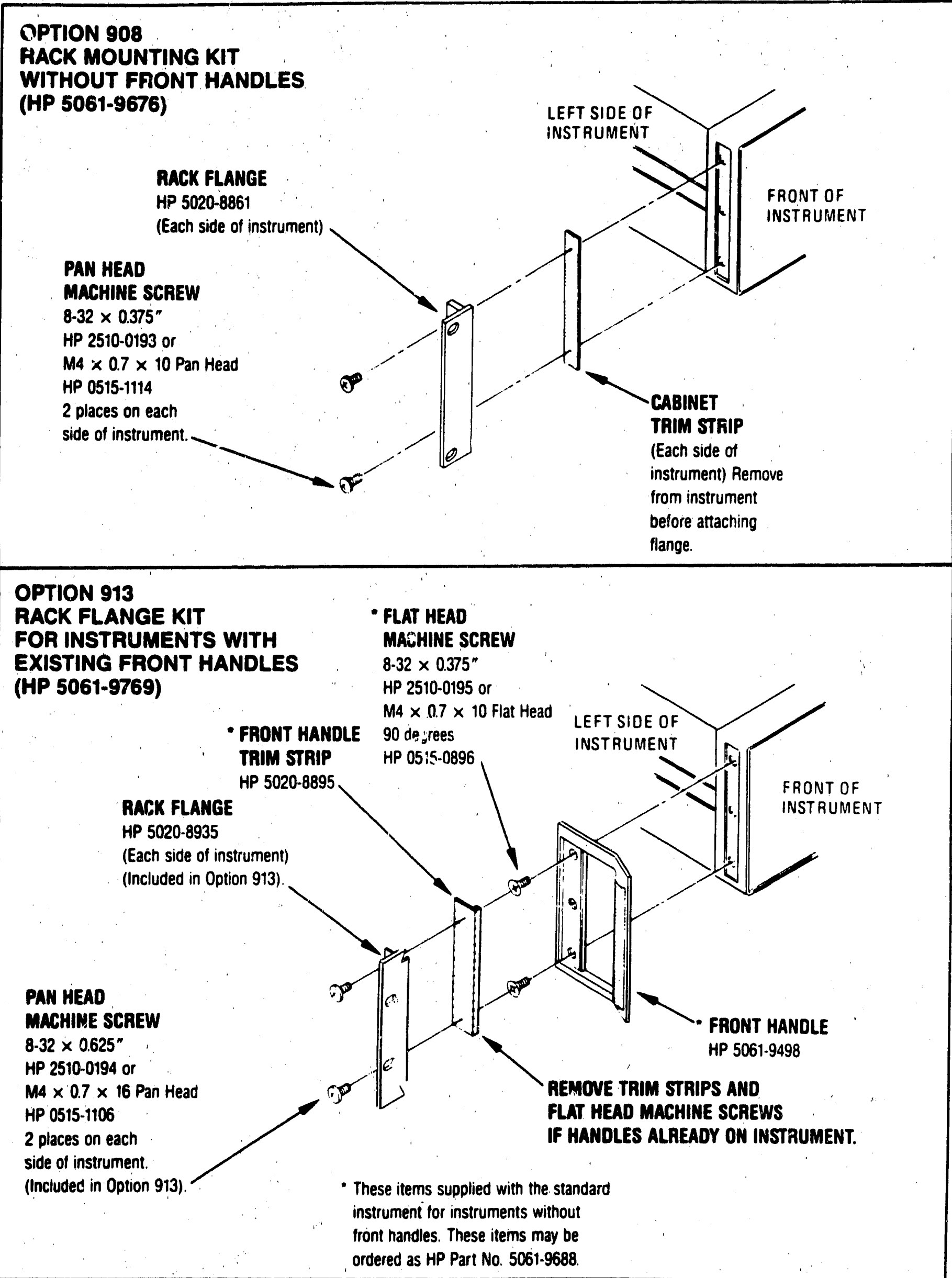

Figure 2-5. Attached Rack Mounting Hardware and Handles (CHANGE 9)