

Part No. Z1-002-802, IB004182

Sep. 2003

## **OPERATION MANUAL**

---

ELECTRONIC LOAD PLZ-4W Series

# **PLZ2004WB**

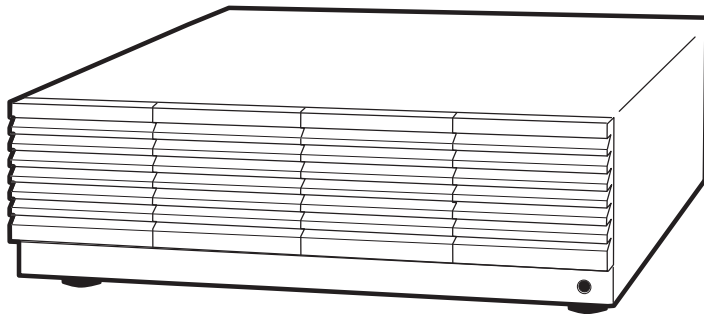

## **Use of Operation Manual**

Please read through and understand this Operation Manual before operating the product. After reading, always keep the manual nearby so that you may refer to it as needed. When moving the product to another location, be sure to bring the manual as well.

If you find any incorrectly arranged or missing pages in this manual, they will be replaced. If the manual it gets lost or soiled, a new copy can be provided for a fee. In either case, please contact Kikusui distributor/agent, and provide the “Kikusui Part No.” given on the cover.

This manual has been prepared with the utmost care; however, if you have any questions, or note any errors or omissions, please contact Kikusui distributor/agent.

Reproduction and reprinting of this operation manual, whole or partially, without our permission is prohibited.

Both unit specifications and manual contents are subject to change without notice.

Copyright© 2003 Kikusui Electronics Corporation

Printed in Japan

# Power Requirements of this Product

Power requirements of this product have been changed and the relevant sections of the Operation Manual should be revised accordingly.

(Revision should be applied to items indicated by a check mark )

## Input voltage

The input voltage of this product is \_\_\_\_\_ VAC,  
and the voltage range is \_\_\_\_\_ to \_\_\_\_\_ VAC. Use the product within this range only.

## Input fuse

The rating of this product's input fuse is \_\_\_\_\_ A, \_\_\_\_\_ VAC, and \_\_\_\_\_ .

- 
- ⚠ WARNING** • To avoid electrical shock, always disconnect the power cord or turn off the switch on the switchboard before attempting to check or replace the fuse.
- Use a fuse element having a shape, rating, and characteristics suitable for this product. The use of a fuse with a different rating or one that short circuits the fuse holder may result in fire, electric shock, or irreparable damage.
- 

## Power cord

The product is provided with power cords described below. If the cord has no power plug, attach a power plug or crimp-style terminals to the cord in accordance with the wire colors specified in the drawing.

- 
- ⚠ WARNING** • The attachment of a power plug or crimp-style terminals must be carried out by qualified personnel.
- 

### Without a power plug

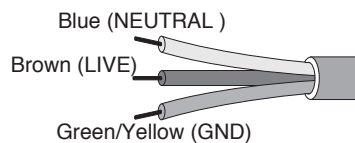

### Without a power plug

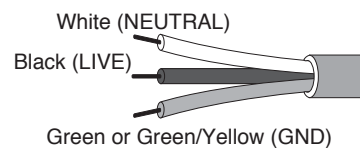

### Plugs for USA

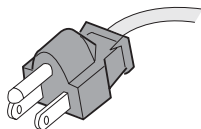

### Plugs for Europe

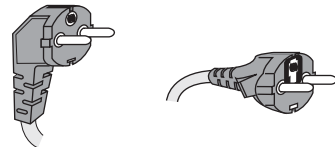

### Provided by Kikusui distributor/agent

Kikusui agents can provide you with suitable power cord.  
For further information, contact Kikusui distributor/agent.



# Safety Symbols

For the safe use and safe maintenance of this product, the following symbols are used throughout this manual and on the product. Understand the meanings of the symbols and observe the instructions they indicate (the choice of symbols used depends on the products).



Indicates that a high voltage (over 1 000 V) is used here. Touching the part causes a possibly fatal electric shock. If physical contact is required by your work, start work only after you make sure that no voltage is output here.

**DANGER**

Indicates an imminently hazardous situation which, if ignored, will result in death or serious injury.



Indicates a potentially hazardous situation which, if ignored, could result in death or serious injury.



Indicates a potentially hazardous situation which, if ignored, may result in damage to the product and other property.



Shows that the act indicated is prohibited.



Is placed before the sign “DANGER,” “WARNING,” or “CAUTION” to emphasize these. When this symbol is marked on the product, see the relevant sections in this manual.



Indicates a protective conductor terminal.



Indicates a chassis (frame) terminal.

# Safety Precautions

The following safety precautions must be observed to avoid fire hazard, electrical shock, accidents, and other failures. Keep them in mind and make sure that all of them are observed properly.



## Users

- This product must be used only by qualified personnel who understand the contents of this operation manual.
- If it is handled by disqualified personnel, personal injury may result. Be sure to handle it under supervision of qualified personnel (those who have electrical knowledge.)
- This product is not designed or manufactured for general home or consumer use.

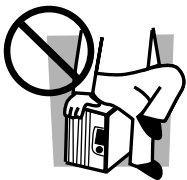

## Purposes of use

- Do not use the product for purposes other than those described in the operation manual.

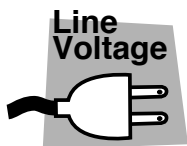

## Input power

- Use the product with the specified input power voltage.
- For applying power, use the power cord provided. Note that the provided power cord is not use with some products that can switch among different input power voltages or use 100 V and 200 V without switching between them. In such a case, use an appropriate power cord.



## Fuse

- With products with a fuse holder on the exterior surface, the fuse can be replaced with a new one. When replacing a fuse, use the one which has appropriate shape, ratings, and specifications.

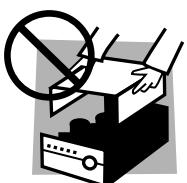

## Cover

- There are parts inside the product which may cause physical hazards. Do not remove the external cover.

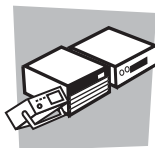

## **Installation**

- When installing products be sure to observe “2.2 Precautions Concerning Installation Location” described in this manual.
- To avoid electrical shock, connect the protective ground terminal to electrical ground (safety ground).
- When connecting the power cord to a switchboard, be sure work is performed by a qualified and licensed electrician or is conducted under the direction of such a person.
- When installing products with casters, be sure to lock the casters.



## **Relocation**

- Turn off the power switch and then disconnect all cables when relocating the product.
- Use two or more persons when relocating the product which weights more than 20 kg. The weight of the products can be found on the rear panel of the product and/or in this operation manual.
- Use extra precautions such as using more people when relocating into or out of present locations including inclines or steps. Also handle carefully when relocating tall products as they can fall over easily.
- Be sure the operation manual be included when the product is relocated.



## **Operation**

- Check that the AC input voltage setting and the fuse rating are satisfied and that there is no abnormality on the surface of the power cord. Be sure to unplug the power cord or stop applying power before checking.
- If any abnormality or failure is detected in the products, stop using it immediately. Unplug the power cord or disconnect the power cord from the switchboard. Be careful not to allow the product to be used before it is completely repaired.
- For output wiring or load cables, use connection cables with larger current capacity.
- Do not disassemble or modify the product. If it must be modified, contact Kikusui distributor/agent.



## **Maintenance and checking**

- To avoid electrical shock, be absolutely sure to unplug the power cord or stop applying power before performing maintenance or checking.
- Do not remove the cover when performing maintenance or checking.
- To maintain performance and safe operation of the product, it is recommended that periodic maintenance, checking, cleaning, and calibration be performed.



## **Service**

- Internal service is to be done by Kikusui service engineers. If the product must be adjusted or repaired, contact Kikusui distributor/agent.

# Overvoltage Category

For the safe use of equipment, IEC60664 (Insulation coordination for equipment within low-voltage systems) classifies circuits into four categories by an occurrence level of transient voltage. When you connect equipment to a power line or connect a measuring instrument to these places, make sure of the applied overvoltage category. This instrument is designed to operate from the overvoltage category II.

## Overvoltage category I

Equipment of overvoltage category I is equipment for connection to circuits in which measures are taken to limit transient overvoltages to an appropriately low level.

Examples are protected electronic circuits.

## Overvoltage category II

Equipment of overvoltage category II is energy-consuming equipment to be supplied from the fixed installation.

Examples of such equipment are appliances, portable tools and other household and similar loads.

If such equipment is subjected to special requirements with regard to reliability and availability, overvoltage category III applies.

## Overvoltage category III

Equipment of overvoltage category III is equipment in fixed installations and for cases where the reliability and the availability of the equipment is subject to special requirements.

Examples of such equipment are switches in the fixed installation and equipment for industrial use with permanent connection to the fixed installation.

## Overvoltage category IV

Equipment of overvoltage category IV is for use at the origin of the installation.

Example of such equipment are electricity meters and primary overcurrent protection equipment.

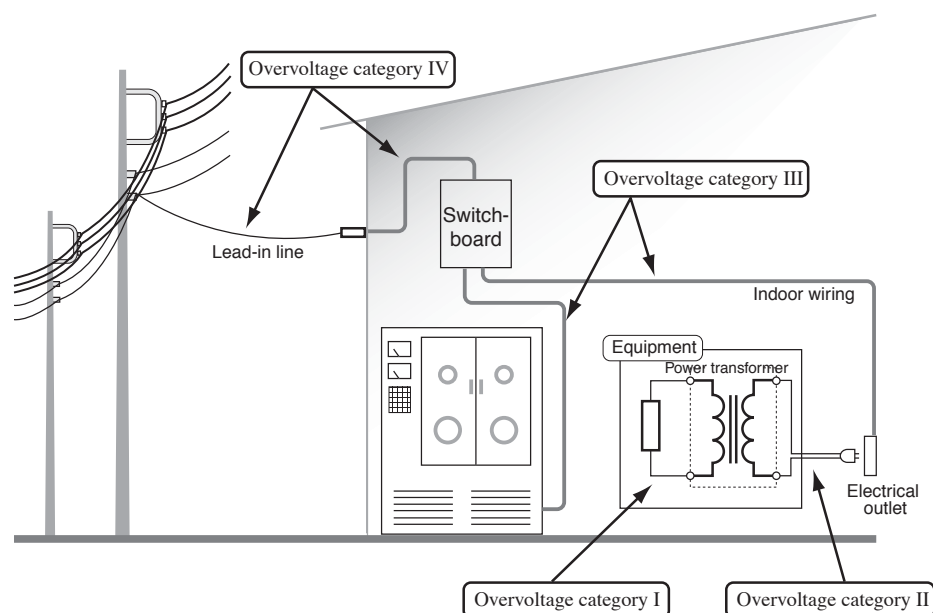



# Arrangement of this Manual

This Operation Manual is made up of the following sections.

## **Chapter 1 General Information**

This chapter gives an overview and describes the features of the PLZ2004WB.

## **Chapter 2 Installation and Preparation**

This chapter describes the procedures of unpacking and preparation of the PLZ2004WB before use.

## **Chapter 3 Names and Functions of Parts**

This chapter describes the names and functions of switches, displays, connectors, and other parts of the front panel and rear panel.

## **Chapter 4 Maintenance**

This chapter describes maintenance and calibration of the PLZ2004WB.

## **Chapter 5 Specifications**

This chapter describes the electrical and mechanical specifications of the PLZ2004WB.

# Contents

<b>Power Requirements of this Product</b> .....	<b>I</b>
<b>Safety Symbols</b> .....	<b>III</b>
<b>Safety Precautions</b> .....	<b>IV</b>
<b>Overvoltage Category</b> .....	<b>VI</b>
<b>Arrangement of this Manual</b> .....	<b>VII</b>
<b>Chapter 1 General Information</b> .....	<b>1-1</b>
<hr/>	
<b>Chapter 2 Installation and Preparation</b> .....	<b>2-1</b>
2.1 Checking the Package Contents .....	2-1
2.2 Precautions Concerning Installation Location .....	2-2
2.3 Precautions When Moving the Unit .....	2-3
2.4 Connecting the Power Cord .....	2-4
2.5 Grounding .....	2-5
2.6 Parallel Connection .....	2-6
2.6.1 Connecting the Signal Cables .....	2-7
2.6.2 Load Wiring .....	2-7
2.7 Setting the Master Unit .....	2-10
<b>Chapter 3 Names and Functions of Parts</b> .....	<b>3-1</b>
3.1 Front Panel .....	3-1
3.2 Rear Panel .....	3-2
<b>Chapter 4 Maintenance</b> .....	<b>4-1</b>
4.1 Cleaning .....	4-1
4.1.1 Cleaning the Panels .....	4-1
4.1.2 Cleaning the Dust Filter .....	4-1
4.2 Inspection .....	4-3
4.3 Calibration .....	4-3
<b>Chapter 5 Specifications</b> .....	<b>5-1</b>
5.1 Electrical Specifications .....	5-1
5.2 General Specifications .....	5-3
5.3 Dimensions .....	5-4
<b>Index</b> .....	<b>I- 1</b>
<hr/>	

This chapter gives an overview and describes the features of the PLZ2004WB.

## About This Manual

This operation manual describes the PLZ2004WB Load Booster.

The PLZ2004WB is used in combination with the PLZ1004W Electronic Load. This manual mainly covers the handling precautions of the PLZ2004WB and the connection to the PLZ1004W. For the operating procedure as a electronic load, see the PLZ1004W Operation Manual.

## Product Overview

The PLZ2004WB Load Booster is used to increase the input current to the PLZ1004W Electronic Load. One PLZ1004W is made the master unit, and load boosters connected in parallel operate as slave units.

## Features

- Up to four load boosters can be connected in parallel with a PLZ1004W master unit, configuring a electronic load that produces up to 9 kW and 1 800 A.
- The master unit displays the total current and total wattage. The units connected in parallel can be used as a single electronic load.
- The connection of the control cables is easy. The control cable used to connect between the master unit and the load booster and between each load booster is one flat cable each.
- There is no power switch. The AC input power is turned ON/OFF by the master unit.

## Options

### Control flat cables

Control cable used to connect between the master unit and the load booster and between load boosters. The following two types of cables are available.

Model	Code	Length	Application
PC01-PLZ-4W	84540	300 mm	Connect between load boosters
PC02-PLZ-4W	84550	550 mm	Connect between the master unit and load booster

The two types of cables only differ in their length. The 550-mm PC02-PLZ-4W is required to connect the master unit and the load booster.

## Rack mount bracket

The following rack mounting brackets are available.

- KRB3-TOS (for inch-rack EIA standard)
- KRB150-TOS (for milli rack JIS standard)

For details, contact Kikusui distributor/agent.

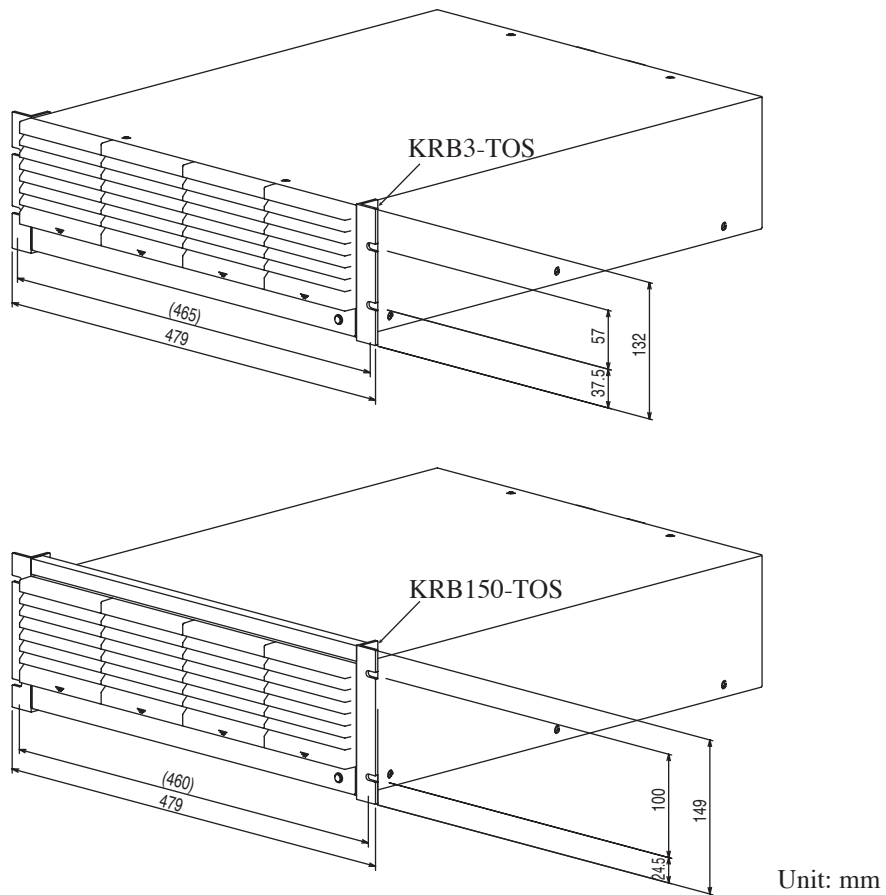

Fig.1-1 Rack mount bracket installation example

This chapter describes the procedures of unpacking and preparation of the PLZ2004WB before use.

## 2.1 Checking the Package Contents

When you receive the product, check that all accessories are included and that the product and accessories have not been damaged during transportation.

If any of the accessories are damaged or missing, contact Kikusui distributor/agent.

**NOTE**

- It is recommended that all packing materials be saved, in case the product needs to be transported at a later date.

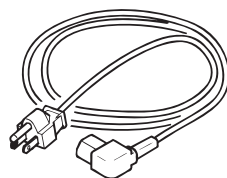

[85-AA-0003]

Or

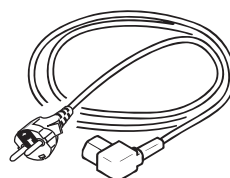

[85-AA-0005]

- Power cord (1 pc.)

The power cord that is provided varies depending on the destination for the product at the factory-shipment.



- Load input terminal cover (2 pcs.) [with auxiliary band]

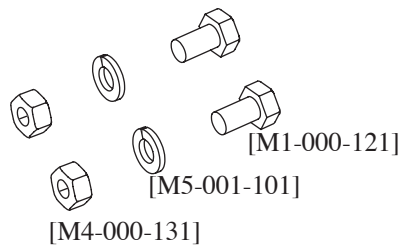

- Set of screws for the load input terminal (2 sets)



- Operation manual (1 copy)

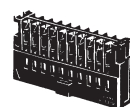

- J2 protection dummy plug (1 pc.) [Attached to the J2 connector on the rear panel.]

Fig.2-1 Accessories

## 2.2 Precautions Concerning Installation Location

This section describes the precautions to be taken when installing the unit. Make sure to observe them.

### ■ Do not use the unit in a flammable atmosphere.

To prevent the possibility of explosion or fire, do not use the unit near alcohol, thinner or other combustible materials, or in an atmosphere containing such vapors.

### ■ Avoid locations where the unit is exposed to high temperature or direct sunlight.

Do not place the unit near a heater or in areas subject to drastic temperature changes.

Operating temperature range: 0 °C to 40 °C

Storage temperature range: -25 °C to +70 °C

### ■ Avoid humid environments.

Do not place the unit in high-humidity locations--near a boiler, humidifier, or water supply.

Operating humidity range: 20 % to 85 % RH (no condensation)

Storage humidity range: 0 % to 90 % RH (no condensation)

Condensation may occur even within the operating humidity range. In such case, do not use the unit until the condensation dries up completely.

### ■ Do not place the unit in a corrosive atmosphere.

Do not install the unit in a corrosive atmosphere or in environments containing sulfuric acid mist, etc. This may cause corrosion of various conductors and bad contacts of connectors inside the unit leading to malfunction and failure, or in the worst case, a fire.

However, operation in such environments may be possible through alteration. If you wish to use the unit in such environments, consult Kikusui distributor/agent.

### ■ Do not place the unit in a dusty location.

Accumulation of dust can lead to electric shock or fire.

### ■ Do not use the unit where ventilation is poor.

The unit employs a forced air cooling system. Air is taken in from intake ports located on panels other than the rear panel and exhausted from the ports on the rear panel. Secure adequate space around the unit to prevent the possibility of fire caused by accumulation of heat.

### ■ Do not place the unit on an inclined surface or location subject to vibrations.

The unit may fall or tip over causing damages and injuries.

- **Do not use the unit in a location subject to strong magnetic or electric fields.**

The unit may malfunction and cause electric shock or fire.

- **Do not use the unit near highly sensitive measuring instruments or transceivers.**

The noise generated by the unit may affect them

- **Do not stack more than two units on top of each other.**

The units (load booster and master unit) can be stacked, but do not stack more than two units on top of each other for safety reasons.

If you are using multiple load boosters, it is recommended that they be mounted on a rack.

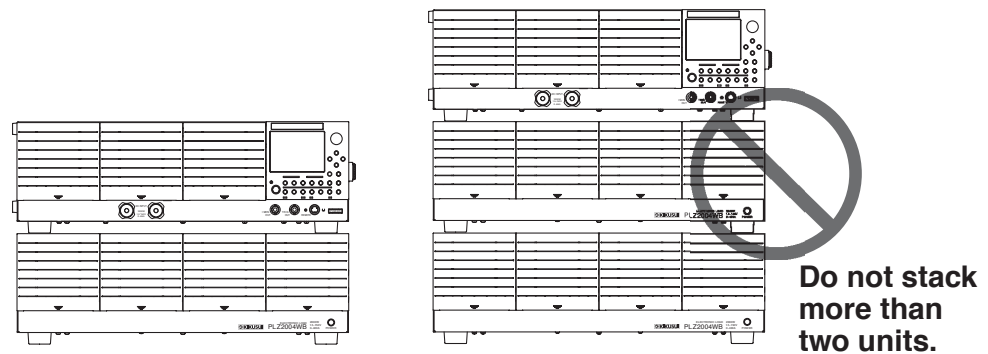

Fig. 2-2 Stacking of the electronic loads

## 2.3 Precautions When Moving the Unit

When moving the unit to the installation location or when transporting the unit, note the following points.

- **Remove all wiring.**

Moving the unit with the cables connected can cause wires to break or injuries due to the unit falling over.

- **Have two or more people move the unit.**

The unit weighs over 20 kg. Have two or more people move the unit. Use extra precaution at inclines and steps.

- **When transporting the unit, be sure to use the original packing materials.**

Otherwise, damage may result from vibrations or from the unit falling during transportation.

## 2.4 Connecting the Power Cord

The power cord that is provided varies depending on the destination for the product at the factory-shipment.

- 
- WARNING**
- This product is designed to be connected to a power supply classified as Overvoltage Category II. Do not connect to a power supply classified as Overvoltage Category III or IV. For a description of the Overvoltage Category, see “Overvoltage Category” on page VI.
  - The power cord for 100-V system shown in Fig. 2-3 has a rated voltage of 125 VAC. If this power cord is used at the line voltage of a 200-V system, replace the power cord with that satisfying that line voltage.
- Have a qualified engineer select the appropriate power cord. If obtaining the right power cord is difficult, contact Kikusui distributor/agent.
- 

- **Do not use the power cord that comes with the product as a power cord for other equipment.**

	Power cord for 100-V system [85-AA-0003] Rated voltage: 125 VAC Rated current: 10 A
	Power cord for 200-V system [85-AA-0005] Rated voltage: 250 VAC Rated current: 10 A

Fig. 2-3 Power cord with a three-pin plug

Follow the procedures below to connect the power cord.

- 
- NOTE**
- The load booster does not have a power switch. The AC input power is turned on/off in sync with the master unit when the load booster is connected to the master unit through the control cable.
- 

1. Check that the AC power supply is within the input power supply range of the product.  
The allowable voltage range and frequency range of the AC input power are 90 VAC to 250 VAC and 47 Hz to 63 Hz, respectively.
2. Connect the power cord to the AC INPUT connector on the rear panel.  
Use a power cord specified by Kikusui or one that has been selected by a qualified engineer.
3. Insert the power plug to the outlet.

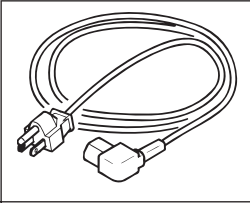
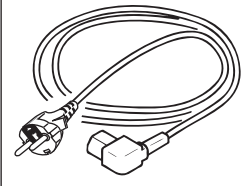

## 2.5 Grounding

- 
- ⚠ WARNING**
- Electric shock may occur, if proper grounding is not furnished.
  - This product is designed as a Class I equipment (equipment furnished with electric shock protection through protective grounding in addition to the basic insulation). Be sure to connect the protective ground terminal to an appropriate earth ground.
- ⚠ CAUTION**
- If you do not ground the product, malfunction may occur due to external noise, or the noise generated by the product may become large.
- 

Make sure to ground the load booster for your safety.

Connect the power cord to a three-prong power outlet with proper grounding.

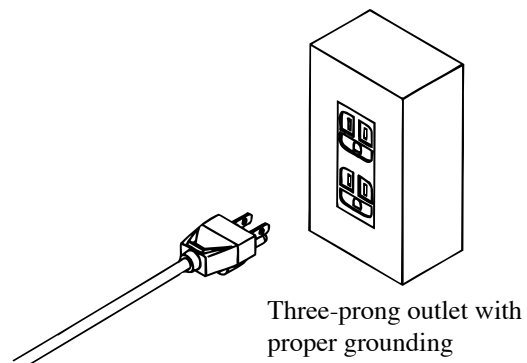

Fig. 2-4 Grounding method

## 2.6 Parallel Connection

To carry out parallel operation, you must connect signal wires used to connect to the master unit and the load cable used to connect to the equipment under test.

Use the optional flat cable for the signal wire. For details, see “Control flat cables” in chapter 1, “General Information.”

Up to four load boosters can be connected. Here, an example in which two load boosters are connected is indicated.

**⚠ WARNING** • There is a danger of electric shock. Do not touch the load connector while the power is on.

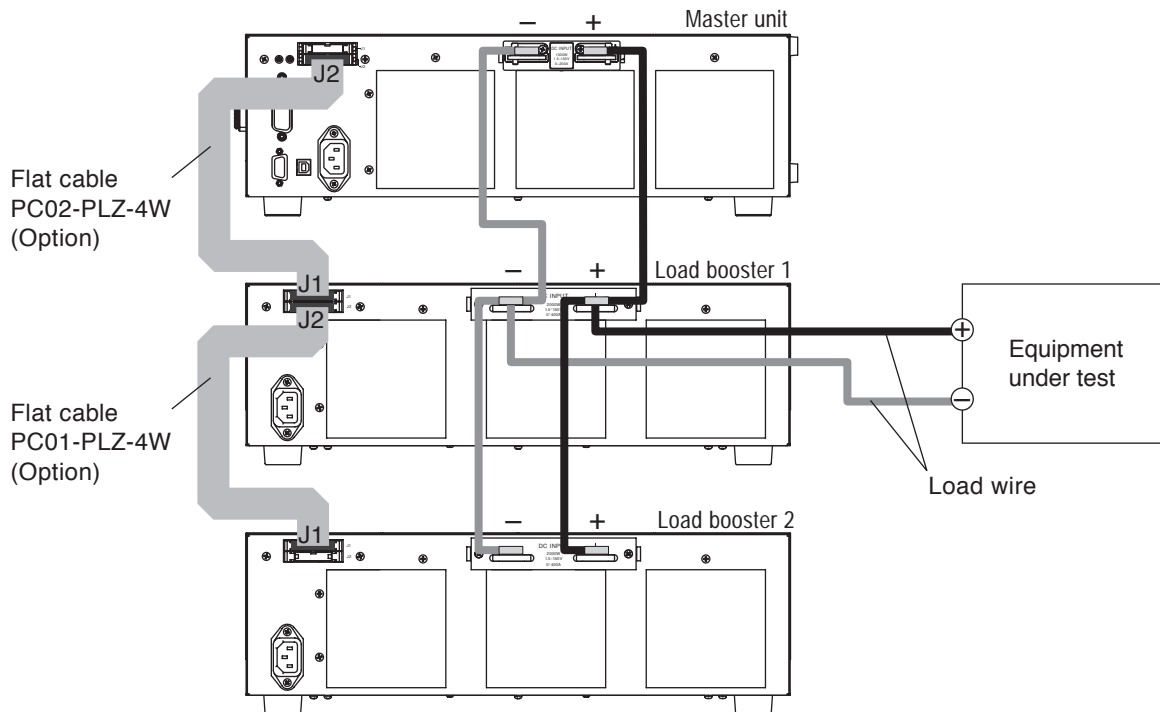

Fig. 2-5 Parallel connection of two load boosters

Table 2-1 shows the relationship between the number of load boosters and the capacity.

Table2-1 The number of load boosters connected in parallel and the capacity

Number of load boosters (n)	Maximum current/maximum power
	PLZ1004W + (PLZ2004WB × n)
1	600 A / 3000 W
2	1000 A / 5000 W
3	1400 A / 7000 W
4	1800 A / 9000 W

- 
- CAUTION**
- Be sure to use the load input terminals on the rear panel on the master unit. Do not connect other equipment to the load input terminal on the front panel.
  - Improper connection of the J1 and J2 connectors can damage the PLZ2004WB.
  - Take into account the current used, and make the load cable as short as possible with sufficient thickness.
- 

- NOTE**
- Separate the load cable from the flat cable as much as possible to prevent unstable operation.
- 

## 2.6.1 Connecting the Signal Cables

Use the optional cable for the connection cable.

1. Turn off the POWER switch on the master unit.
2. Unplug the power cord plug of the load booster.
3. Connect between J2 of the master unit and J1 of load booster 1 using the optional flat cable (PC02-PLZ-4W).
4. Connect between J2 of load booster 1 and J1 of load booster 2 using the optional flat cable (PC01-PLZ-4W).

When connecting more load boosters, make similar connections.

## 2.6.2 Load Wiring

- 
- NOTE**
- Precautions and items to be considered during load wiring when using the master unit alone also apply to parallel operation.

Before wiring the load for parallel operation, read section 2.8, “Load Wiring” in the PLZ1004W Operation Manual to familiarize yourself with the precautions and items to be considered.

---

### Electric wire used

- 
- CAUTION**
- Use a load wire with sufficient diameter for the current as well as non-flammable or flame-resistant cover.
- 

A table indicating “nominal cross-sectional area of wires and allowable currents” is given in section 2.8, “Load Wiring” in the PLZ1004W Operation Manual. Refer to this table and select the thickest wire possible.

## Connection to the load input terminal

The load input terminal on the PLZ1004W (master unit) is not designed for large currents as in the load input terminal of the load booster.

As shown in Fig. 2-5, separate the load wire from the equipment under test for the master unit and the load booster.

**⚠ WARNING** • There is a danger of electric shock. Do not touch the load input terminal while the power is on.

In addition, be sure to use the load input terminal cover.

**⚠ CAUTION** • There is a danger of overcharge. Attach crimping terminal to the wire and use the set of screws that came with the package for connection.

1. Turn off the POWER switch on the master unit.
2. Unplug the power cord plug of the load booster.
3. Check that the output of the equipment under test is off.
4. Connect the load wire to the load input terminal of the master unit.  
For the connection procedure of the load wire, see section 2.8, “Load Wiring” in the PLZ1004W Operation Manual.
5. As shown in Fig. 2-6, connect the load wire to the load input terminal of the load booster.  
Use the load input terminal cover. See Fig. 2-7 on how to use the cover.
6. Connect the master unit, load booster, and the equipment under test.
7. Check the polarity of the connections.

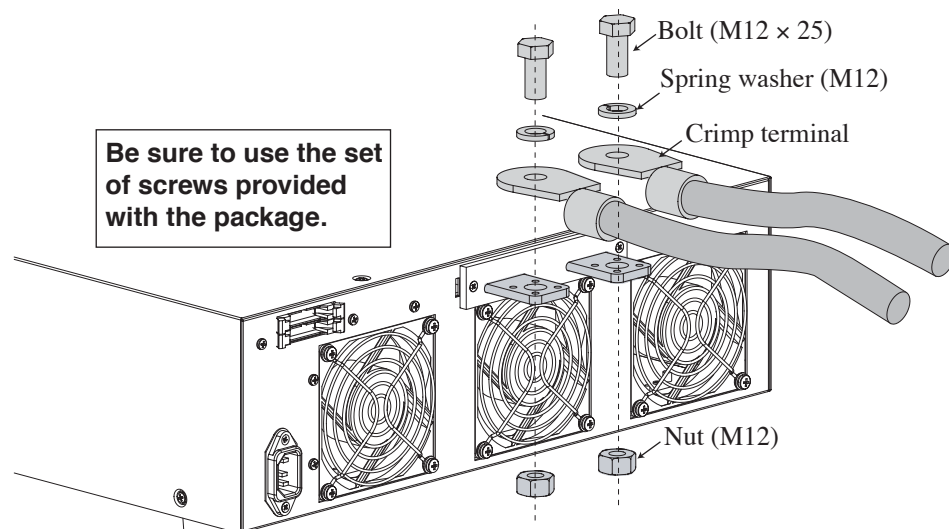
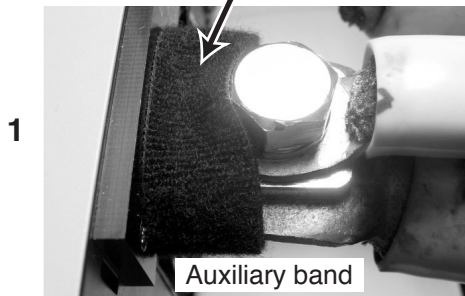
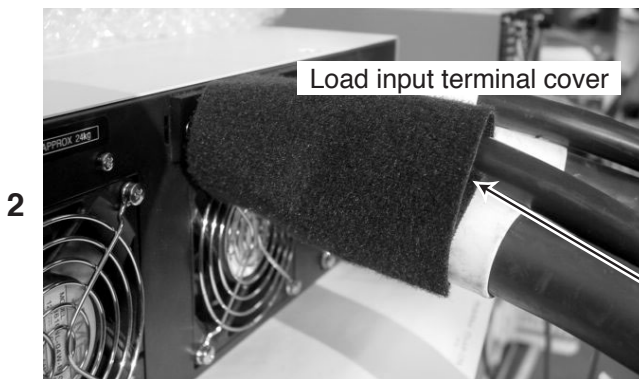

Fig. 2-6 Connection to the load input terminal



Wrap the auxiliary band between the rear panel and the bolt.  
**The auxiliary band prevents the load input terminal cover from sliding. Wrap the band tightly to fill up the space between the panel and the bolt.**



Wrap the load input terminal cover over the auxiliary band.

**Wrap the cover leaving as little space as possible here.**

Fig. 2-7 Attachment of the load input terminal cover

## 2.7 Setting the Master Unit

1. Turn on the power to the master unit.  
The power to the load booster is in sync with the power to the master unit.
2. Select the menu setup.  
Press the MENU (SHIFT+SET/VSET) key.  
The menu appears.
3. Select Configuration  
Press the ▼ or ▲ CURSOR key several times until Configuration is highlighted. When highlighted, press the ENTER key.
4. Select Master/Slave  
Press the ▼ or ▲ CURSOR key several times until Master/Slave is highlighted. When highlighted, press the ENTER key.
5. Set the master unit.  
Check to see that the cursor (blinking) is at the Operation item. If the cursor is at some other item, press the ▲ CURSOR key several times to move the cursor to Operation.
6. Set as a master unit.  
First, turn the rotary knob to the right to select MASTER.  
Press the ▼ CURSOR key twice to move the cursor (blinking) to the Booster item.  
Turn the rotary knob to set the number of load boosters.
7. Exit from the menu.  
Press the MENU (SHIFT+SET/VSET) key.  
On the master unit, the original screen displayed before entering menu setup appears.
8. Power cycle the master unit.  
The menu settings are confirmed.
9. Set the operation mode and value, and turn on the load.  
Operate the master unit to set the master mode and value of the parallel connection. The range of the rated current and rated power on the master unit is expanded.  
After entering the settings, turn off the load.

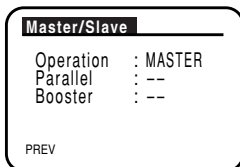

This chapter describes the names and functions of switches, displays, connectors, and other parts of the front panel and rear panel.

## 3.1 Front Panel

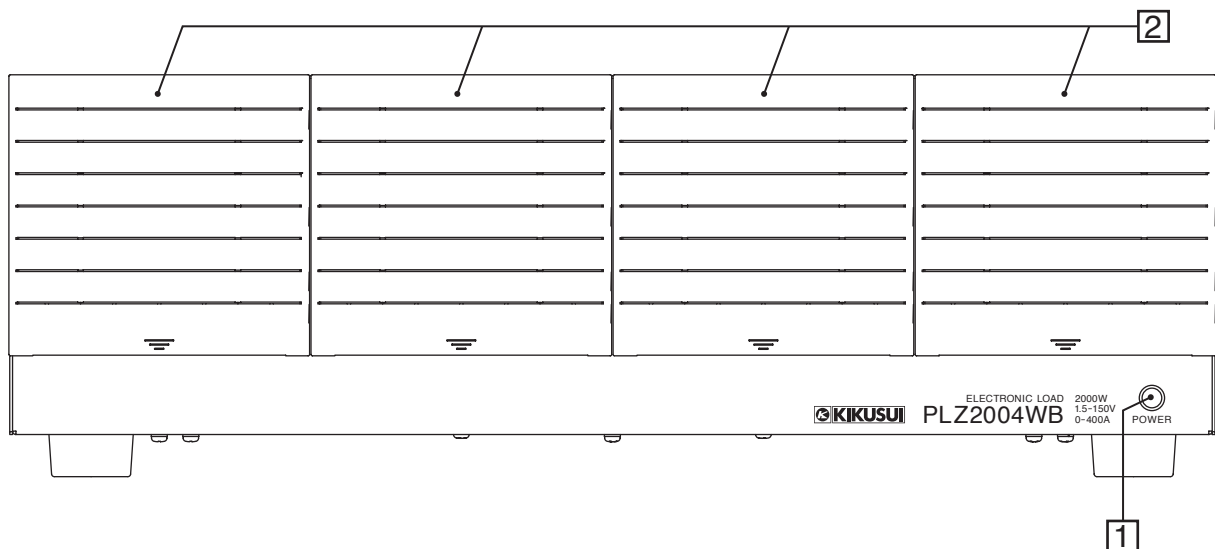

Fig.3-1 PLZ2004WB Front Panel

### [1] POWER lamp

Illuminates when the power switch of the master unit is on when the load booster is connected in parallel with the master unit. It indicates that AC input power is being supplied.

The PLZ2004WB does not have a power switch. The AC input power is turned ON/OFF by the master unit.

### [2] Air intake (louver)

Inlet port used to exhaust the internal heat using a fan.

A dust filter is furnished on the inside. Clean the dust filter periodically. For details, see section 4.1.2, "Cleaning the Dust Filter."

## 3.2 Rear Panel

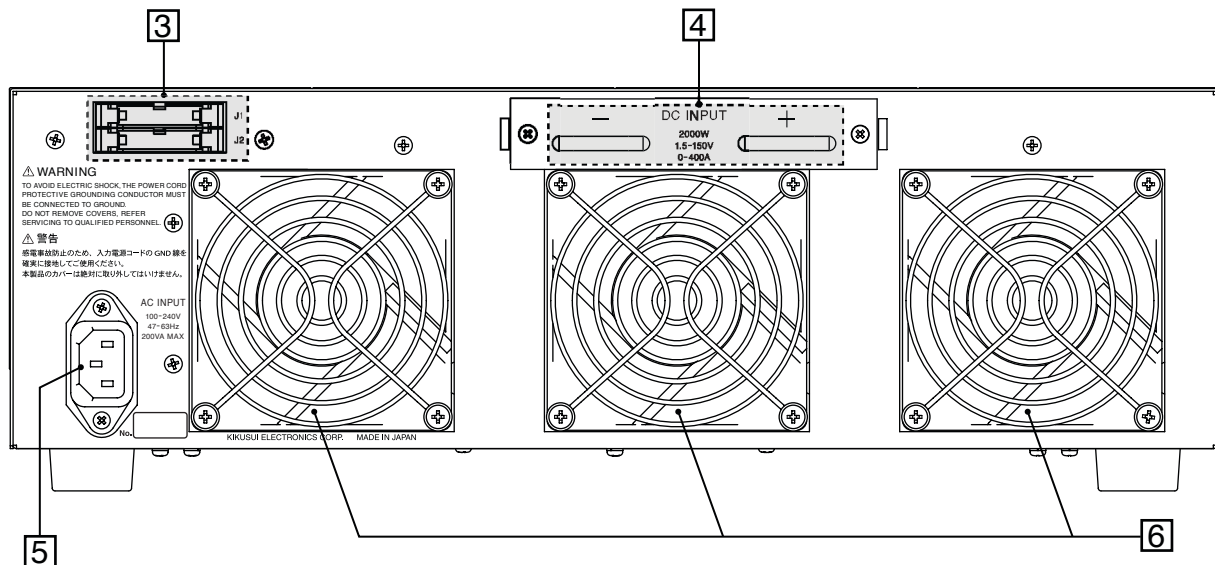

Fig. 3-2 PLZ2004WB Rear panel

[3] J1 and J2 connectors

Connector used to connect the control signal using the optional flat cable.

[4] DC INPUT (Load input terminal)

Input connector used to connect to the equipment under test.

[5] AC INPUT connector

AC power input connector.

---

**⚠ WARNING** • Possible electric shock. May lead to death or injury. Be sure to follow the directions given in section 2.4, “Connecting the Power Cord.”

---

[6] Air outlet

Air outlet used to exhaust the internal heat using a fan. Provide adequate space around the PLZ2004WB to allow sufficient air circulation.



This chapter describes maintenance and calibration of the PLZ2004WB.

- 
- ⚠ WARNING** • Possible electric shock. May lead to death or injury. Do not remove the external cover.
- 

## 4.1 Cleaning

- 
- ⚠ WARNING** • Possible electric shock. May lead to death or injury. Be sure to unplug the power cord plug.
- 

### 4.1.1 Cleaning the Panels

If the panel needs cleaning, gently wipe using a soft cloth with water-diluted neutral detergent.

- 
- ⚠ CAUTION** • Do not use volatile solvents such as thinner or benzene. They may discolor the surface or erase the printed characters.
- 

### 4.1.2 Cleaning the Dust Filter

A dust filter is installed on the inside of the louver on the front panel. Periodically clean the filter to prevent clogging.

- 
- ⚠ CAUTION** • Clogged filters hinder the cooling of the inside of the instrument and can cause a malfunction and shortening of the service life.
-

## Cleaning procedure

1. Remove the louver from the panel by placing a finger on the 2nd level of the louver and pulling down the 1st level while pulling it toward you.  
If the louver does not come off easily, pressing down the top level of the louver will ease the work.

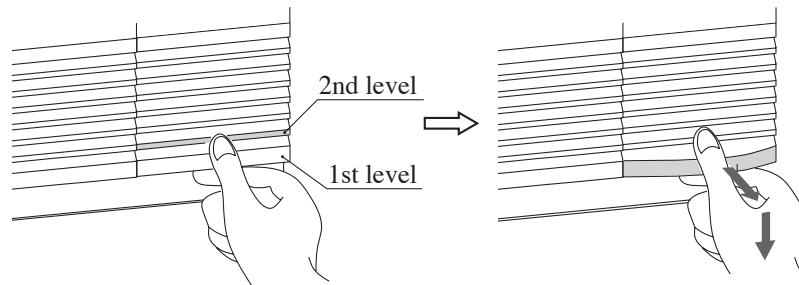

Fig.4-1 Removing the louver

2. Remove the dust filter from the inside of the louver and clean it.

Remove the dust on the dust filter such as by using a vacuum cleaner. If the filter is extremely dirty, clean it using a water-diluted neutral detergent and dry it completely.

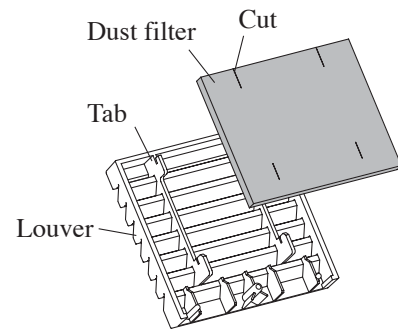

Fig. 4-2 Dust filter

---

**CAUTION** • When the PLZ2004WB is in operation, air is sucked through the dust filter to cool the load booster. If moisture is included in the dust filter, the temperature or humidity inside the PLZ2004WB increases and may cause a malfunction.

---

3. Attach the dust filter to the louver.  
Attach it so that the tab on the louver fits into the cut on the dust filter.
4. Attach the louver to the panel by pulling up on the louver while holding the 2nd level of the louver with your hand until the pin is fixed in place.

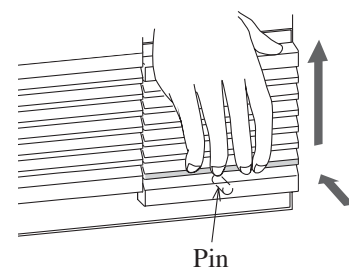

Fig. 4-3 Attaching the louver

---

## 4.2 Inspection

### Power cord

Check that the insulation coating is not broken and that the crimp terminal is not loose.

- 
- ⚠ WARNING**
- Possible electric shock. May lead to death or injury. Be sure to unplug the power cord plug.
  - Breaks in the insulation coating may cause electric shock. If a break is found, stop using it immediately.
- 

To purchase accessories, contact Kikusui distributor/agent.

## 4.3 Calibration

The PLZ2004WB is shipped from the factory after carrying out a strict calibration. However, to maintain the performance, periodic calibration is recommended.

Calibration can be performed in the same fashion as the calibration of the master unit alone by viewing the load device connected in parallel (master unit and load boosters) as a single load device. For details, see section 8.2, “Calibration” in the PLZ1004W Operation Manual.

Use shunt resistors and regulated DC power supplies of appropriate current capacity in the calibration.



This chapter describes the electrical and mechanical specifications of the PLZ2004WB.

## 5.1 Electrical Specifications

Unless specified otherwise, the specifications are for the following settings and conditions.

- Warm-up period: 30 minutes (with current flowing)
- Ambient temperature:  $23\text{ °C} \pm 5\text{ °C}$
- \*\* % of set denotes \*\* % of the input voltage, input current, or input power setting.
- \*\* % of f.s denotes \*\* % of the rated input voltage, rated input current, or rated input power.

### Rating

Operating voltage (DC)		1.5 V to 150 V	
Current		400 A	
Power		2000 W	
Minimum operating start voltage <sup>*1</sup>		0.3 V or greater	
Current setting accuracy <sup>*2</sup>	Range	H and M	$\pm(1.2\% \text{ of set} + 1.1\% \text{ of f.s.}^{*3})$
		L	$\pm(1.2\% \text{ of set} + 1.1\% \text{ of f.s.})$

\*1 Minimum voltage at which the current starts flowing to the PLZ2004WB.

\*2 Condition in which the PLZ2004WB is connected to the master unit but not calibrated.

\*3 Full scale of H range.

### Protection function

Overheat protection (OHP)	Turns off the load when the heat sink temperature reaches 95 °C.
Reverse connection protection (REV)	Protection by fuse.

## Input/output signal

J1 connector		20-pin MIL connector Used to connect to the master unit (or load booster)	J2 connector		20-pin MIL connector Used to connect to load booster n
1	NC		1	NC	
2	NC		2	NC	
3	NC		3	NC	
4	SUM I MON	Connect to SUM I MON of the J2 connector.	4	SUM I MON	Connect to SUM I MON of the J1 connector.
5	PRL IN+	Connect to PRL OUT+ of the J2 connector.	5	PRL OUT+	Connect to PRL IN+ of the J1 connector.
6	PRL IN-	Connect to PRL OUT- of the J2 connector.	6	PRL OUT-	Connect to PRL IN- of the J1 connector.
7	NC		7	NC	
8	NC		8	NC	
9	RANGE CONT 0	Connect to SLAVERANGE CONT of the J2 connector.	9	SLAVERANGE CONT	Connect to RANGE CONT 0 of the J1 connector.
10	NC		10	NC	
11	NC		11	NC	
12	A COM	Connect to the negative load input terminal.	12	A COM	Connect to the negative load input terminal.
13	NC		13	NC	
14	NC		14	NC	
15	NC		15	NC	
16	ALARM OUTPUT	Activates an alarm with high (or low) TTL level signal input.	16	ALARM INPUT	Activates an alarm with high (or low) TTL level signal input.
17	A COM	Connect to the negative load input terminal.	17	A COM	Connect to the negative load input terminal.
18	NC		18	NC	
19	A COM	Connect to the negative load input terminal.	19	A COM	Connect to the negative load input terminal.
20	+15V	For controlling the on/off of the load booster power (multi-purpose use not allowed)	20	+15V	For controlling the on/off of the load booster power (multi-purpose use not allowed)

## 5.2 General Specifications

Environment	Operating temperature and humidity range	Temperature: 0 °C to 40 °C Humidity: 20% to 85% RH (no condensation)
	Storage temperature and humidity range	Temperature: -25 °C to 70 °C Humidity: Less than or equal to 90% (no condensation)
Input line voltage range		100 VAC to 240 VAC (90 VAC to 250 V) single phase, continuous
Input frequency range		47 Hz to 63 Hz
Power consumption		200 VAmax
Inrush current		35 A
Insulation resistance	Primary - input connector	500 VDC, 30 MΩ or more (ambient humidity of 70% RH or less)
	Primary - chassis	500 VDC, 30 MΩ or more (ambient humidity of 70% RH or less)
	Input connector - chassis	500 VDC, 30 MΩ or more (ambient humidity of 70% RH or less)
Withstand voltage	Primary - input connector	No abnormalities at 1500 VAC for 1 minute.
	Primary - chassis	No abnormalities at 1500 VAC for 1 minute.
Dimensions (mm)		See outline drawing.
Weight		Approx. 24 kg
Accessories	Power cord	1 pc. (with SVT3, 18AWG, 3-prong plug, cable length of 2.4 m)
	Load input terminal cover	2 sets (cover and auxiliary band)
	Screw set for th load input terminal	2 sets (bolts, nuts, and spring washers)
	Operation manual	1 pc.
	J2 protection dummy flag	1 pc.
Electromagnetic compatibility (EMC) <sup>*1</sup>		Conforms to the requirements of the following directive and standard. EMC Directive 89/336/EEC EN61326:1997/A2:2001 Emissions: Class A Immunity: Minimum immunity test requirements EN61000-3-2:2000 EN61000-3-3:1995/A1:2001
Safety <sup>*1,*2</sup>		Conforms to the requirements of the following directive and standard. Low Voltage Directive 73/23/EEC EN61010-1:2001 Class I Pollution degree 2

\*1 Only on models that have CE marking on the panel.  
Not applicable to custom order models.

\*2 This instrument is a Class I equipment. Be sure to ground the protective conductor terminal of the instrument. The safety of the instrument is not guaranteed unless the instrument is grounded properly

## 5.3 Dimensions

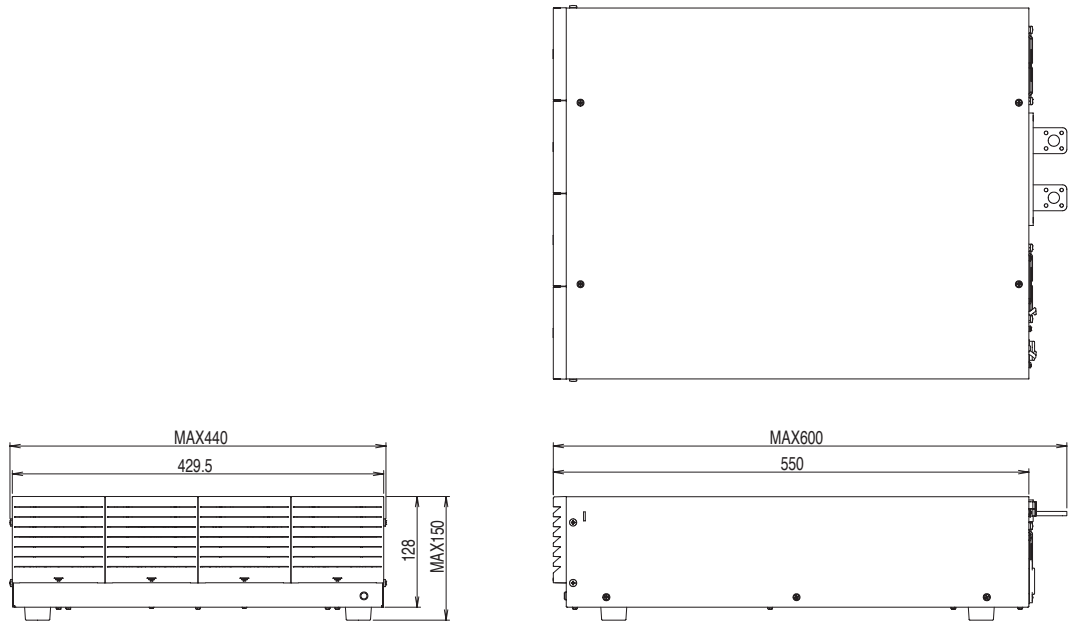

Unit: mm

Fig.5-1 PLZ2004WB outline drawing



# Index

## A

AC INPUT connector 3-2  
accessories 2-1  
air intake 3-1  
air outlet 3-2

## C

calibration 4-3  
Class I equipment 2-5  
cleaning 4-1  
control flat cables 1-1

## D

DC INPUT 3-2  
dust filter 4-1

## E

earth ground 2-5

## G

grounding 2-5

## I

inspection 4-3  
installation 2-2

## J

J1 connector 3-2  
J2 connector 3-2

## L

load input terminal 3-2  
louver 3-1

## M

moving the unit 2-3

## O

overvoltage category -VI  
Overvoltage Category II 2-4

## P

POWER lamp 3-1

## R

rack mount bracket 1-2

## T

transportation 2-3





