



**ROHDE & SCHWARZ**

Manual

## TRIPLE DC POWER SUPPLIES

NGT 20	177.7133.02
NGT 25	192.0503.02
NGT 35	191.2019.02

Please specify type, order number and serial number of unit when making general inquiries or for ordering spare parts.

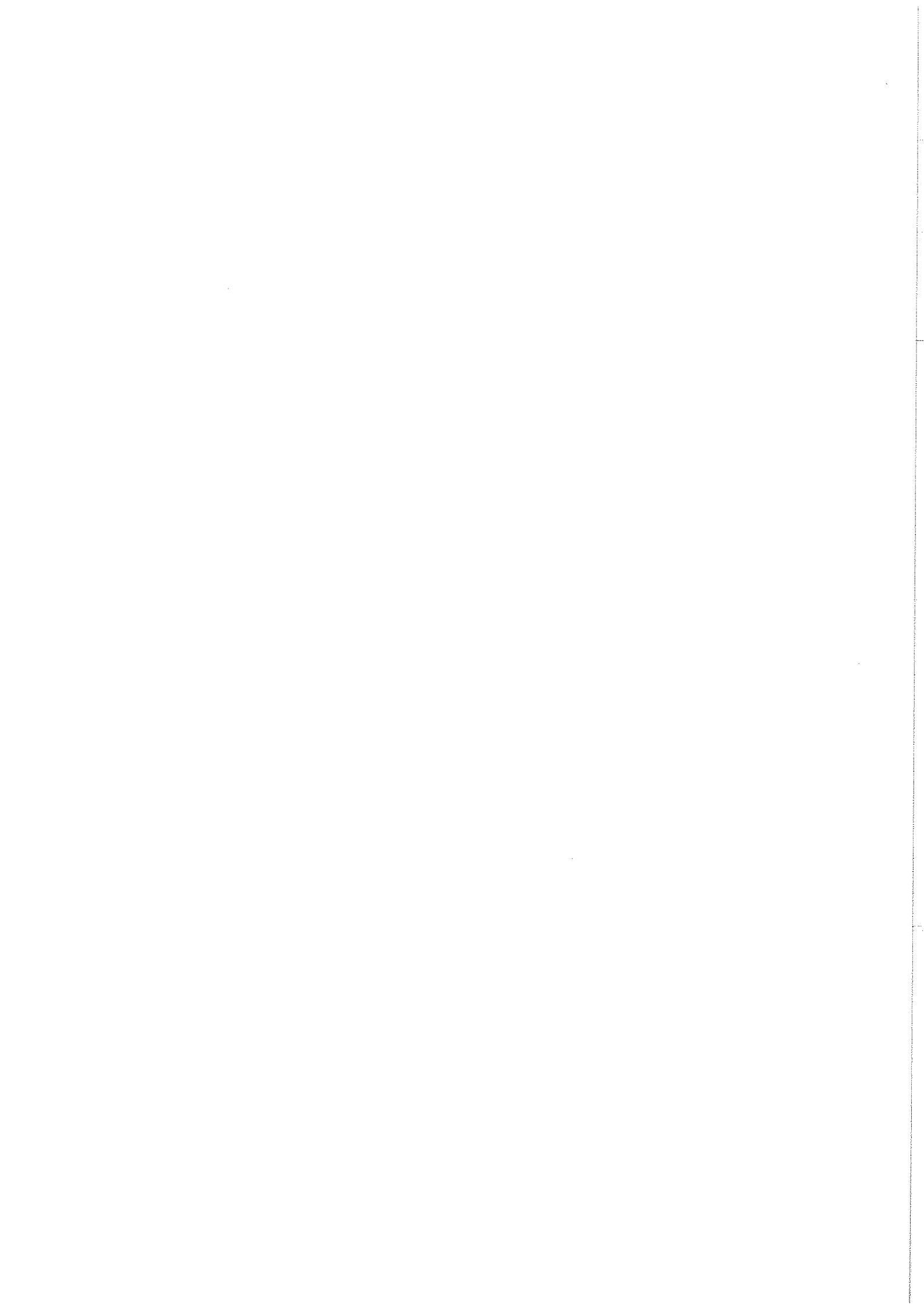

Table of Contents

<u>1.</u>	<u>General</u> .....	3
1.1	Special Features .....	3
1.2	Characteristics and Uses .....	3
1.3	Designation of Part Units .....	4
<u>2.</u>	<u>Specifications</u> .....	5
<u>3.</u>	<u>Preparation for Use and Operation</u> .....	7
3.1	Connecting to the Local AC Supply and Switching On .....	7
3.2	Operation .....	7
3.3	Adjustment .....	7
3.4	Effective Operating Mode .....	8
3.5	Overvoltage Protection for Channel C .....	8
3.6	Series and Parallel Connection of Channels A and B .....	9
3.7	Tracking of Channels A and B .....	10
3.8	Thermal Protection .....	10
<u>4.</u>	<u>Description</u> .....	11
4.1	Principle of Voltage Regulation .....	11
4.2	Principle of Current Regulation .....	12
4.3	Principle of Tracking Operation .....	12
4.4	Circuit Details .....	13
4.5	Overvoltage Protection .....	14
<u>5.</u>	<u>Maintenance and Calibration</u> .....	16
5.1	Calibration of Output Voltage and of Voltage Indication .....	16
5.2	Calibration of Output Current and of Current Indication .....	17
5.3	Calibration for Tracking Operation .....	17
<u>6.</u>	<u>Circuit diagrams etc.</u> .....	
6.1	Overall circuit diagram .....	18
6.2	Circuit diagram of overvoltage protection .....	19
6.3	Components plan of regulator board .....	20
6.4	Table of channel-dependent components .....	21

## 1. General

### 1.1 Special Features

The Triple DC Power Supplies of the Type Series NGT can be used as constant-voltage sources with current limiting or, for less stringent requirements, as constant-current sources. They have the following distinguishing features:

- o Separate operation, series or parallel connection of the three voltage sources
- o Tracking operation of the equipment channels A and B possible
- o Overvoltage protection for 6-V output (channel C)
- o High-resolution voltage setting with ten-turn potentiometer
- o Rectangular characteristic for current limiting
- o Short-circuit proof, protected against wrong polarity and reverse current
- o Meter for each output, switchable to voltage or current
- o Light indication of current limiting
- o Floating outputs, test voltages 1000 V to earth

### 1.2 Characteristics and Uses

The DC Power Supplies of Type Series NGT accommodate in one unit three independent voltage sources for the simultaneous supply of linear and digital integrated circuits. Their characteristics match the standardized specifications of integrated circuits but they are also suitable for universal use. The neat layout of the front-panel controls, the switchable meter and the light indication of current limiting for each output ensure simple and error-free operation. Excellent regulation is combined with high resolution of the ten-turn potentiometers for voltage setting.

The two equivalent channels A and B are mainly designed for the supply of linear IC's; they can be used individually, connected in series or parallel or employed in tracking operation. In the latter mode - switch-selected on the front panel - the two outputs are internally connected in series: one positive and one negative voltage are available with respect to the inter-connected terminals in the middle. The negative voltage can be adjusted to any portion of the positive voltage and is automatically varied in proportion to any change thereof. The current limit is set independently for the two

outputs. Influences caused by variations of balanced or unbalanced supply voltages can thus be easily investigated in tracking operation.

The independent 6-V output with a loading capacity of 5 A is especially suitable for the supply of digital IC's. A built-in overvoltage protection circuit with continuously adjustable threshold (4.5 to 10 V) shorts the output via a thyristor when the threshold voltage is exceeded.

### 1.3 Designation of Part Units

The following designations are used in this manual:

	<u>NGT 20</u>	<u>NGT 35</u>	<u>NGT 25</u>
Channel A = left-hand unit	20 V	35 V	25 V
Channel B = centre unit	20 V	35 V	25 V
Channel C = right-hand unit	6 V	6 V	6 V

## 2. Specifications

Ranges	35-V outputs	25-V outputs	20-V outputs	6-V output
Output voltage adjustable by ten-turn potentiometer	< 10 mV...35 V	< 10 mV...25 V	< 10 mV...20 V	< 10 mV...6 V
Resolution		< 0.02 %		
Response threshold of overvoltage protection (preset)	-	-	-	4.5...10 V
Current limiting adjustable by one-turn potentiometer	< 10 mA...0.6 A	< 10 mA...0.8 A	< 10 mA...1 A	< 10 mA...5 A
Resolution		< 1 %		
<b>Characteristics</b>				
Deviation of output voltage at an AC supply voltage variation of $\pm 10$ %				
at temperature variations between -10...+40 °C		< $10^{-4}/^{\circ}\text{C}$		
at load variations from 10 to 90 %	< 0.006 %	< 0.008 %	< 0.01 %	< 0.09 %
Ripple and noise	$V_{\text{rms}} < 0.25 \text{ mV}$	$V_{\text{rms}} < 0.2 \text{ mV}$	$V_{\text{rms}} < 0.15 \text{ mV}$	$V_{\text{rms}} < 0.2 \text{ mV}$
Transient recovery time following a sudden change from no load to full load (return to 0,1 % of rated voltage)				
Deviation of output current at an AC supply voltage variation of $\pm 10$ %		< 0.2 %		
at temperature variations between -10...+40 °C		< $10^{-3}/^{\circ}\text{C}$		
at load variations from 10 to 90 %	< 0.4 %	< 0.35 %	< 0.25 %	< 0.3 %



### 3. Preparation for Use and Operation

#### 3.1 Connecting to the Local AC Supply and Switching On

The set is factory-adjusted for operation from 220 V AC supply. To adapt it to 110 V, change the position of the voltage selector on the rear panel and insert 4-A fuses.

Connect the set to the local AC supply via the patch cord brought out at the rear, which is provided with a plug with earthing contact. When the set is switched on, the lamp in the power switch on the front panel lights.

#### 3.2 Operation

The operating controls of the three channels are arranged in the same order. The left-hand ten-turn potentiometers are used for VOLTAGE adjustment and the right-hand ones for CURRENT. The toggle switches marked INSTRUMENT permit the selection of voltage (V) or current (A) indication. Connect the load to the floating terminals marked + and -. The sockets provided in between and marked with the earth symbol are connected to chassis and to the non-fused earth conductor. A green lamp above the current potentiometer lights when the regulation of the associated channel operates with current limiting (see section 3.4). For TRACKING operation see section 3.7.

#### 3.3 Adjustment

A high voltage setting accuracy or reproducibility can be obtained by appropriate use of the scales on the setting controls, taking full advantage of the linearity of the ten-turn potentiometers. This can be illustrated on a 20-V channel (see drawing).

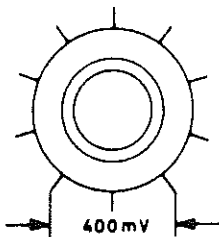

Voltage scale for channels  
A and B at NGT 20

Each turn of the setting control corresponds to one tenth of the maximum output voltage, in this case 2 V. This value is given next to the zero marking. The scale is divided into ten 0.2-V sections; a setting accuracy of  $\pm 0.05$  V can thus be obtained by interpolation (the 6-V channel and 35-V channel have another suitable voltage scale). A voltage of, say, 6.6 V thus requires  $3 \frac{3}{10}$  turns ( $3 \times 2 \text{ V} + 3 \times 0.2 \text{ V}$ ). The current



potentiometers have 10-division scales which permit reproducible setting of the current limiting threshold. Current values, in particular low ones, can be adjusted by shorting the output terminals via a precision ammeter and reading the adjusted current limit.

### 3.4 Effective Operating Mode

The diagram shows a typical current/voltage characteristic. If the current flowing through the load is less than the preset limit, the unit operates on the almost horizontal branch of the characteristic, i.e. in the constant-voltage mode. If the load resistance is reduced until the current reaches the preset limit at the set voltage, the operating point shifts to the almost vertical branch, i.e. the constant-current mode. This is indicated by a green lamp above the current potentiometer.  $\Delta V$  and  $\Delta I$  in the diagram denote the variation of output voltage and output current caused by a load change from 0 to 100%.

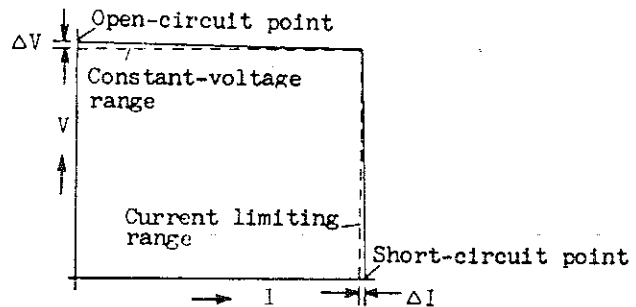

### 3.5 Overvoltage Protection for Channel C

Channel C (6-V output) is protected against overvoltage. The circuit board carrying the protective circuit is accessible when the right-hand side wall is removed. The potentiometer with the slotted screw for setting the response threshold (4.5 to 10 V) is accessible through a plastic socket in the wall. Should a defect or operating error cause the terminal voltage to rise above the preset threshold, the terminals are slotted via a thyristor. To adjust or change the response threshold proceed as follows:

- o Turn the potentiometer fully clockwise with a screwdriver.
- o Switch the panel meter for voltage indication (V). Adjust the output voltage to the desired response threshold.
- o Slowly turn the potentiometer for overvoltage protection counterclockwise until the output voltage breaks down (green lamp lights).

- o Reduce the output voltage by a few per cent. Switch the unit off and on again. The overvoltage protection should not respond.
- o Increase the output voltage and check the adjusted response threshold.
- o Reduce the voltage, briefly switch the unit off and on, and adjust the output voltage to the required value.

A current of over 10 mA should be preset, so that after firing the current of the thyristor is not falling below the holding current, as this would lead to periodic switching. The threshold of the overvoltage protection should be at least 0.3 V above the required and set output voltage of the unit to safely preclude unwanted response. The threshold is factory-adjusted to the nominal voltage (max. output voltage).

To reset the overvoltage protection, the unit must be briefly switched off and the cause of the response removed.

Note: Should the thyristor have become very warm, due to full current flowing over a longer period of time after the overvoltage protection has responded, it may fire again immediately after switching on even if the overvoltage has been removed. In this case, allow 5 to 10 minutes for the set to cool off.

### 3.6 Series and Parallel Connection of Channels A and B

Series connection is possible provided the correct polarity is observed. The permissible test voltage at the output sockets to chassis or earth is 1000 V. The relevant VDE regulations should be observed. Parallel connection should best be made only for channels A and B.

Note: When channels A and B are connected in parallel, the TRACKING switch must be at OFF.

The parallel connection of a channel A- or B-output with the 6-V output (channel C) is possible but implies the risk of damage to the components of channel C if by mistake the output voltage should be adjusted higher than the nominal voltage of channel C (6 V). In this case, the overvoltage protection of channel C is not effective since its current-handling capacity is exhausted by the maximum output current of channel C (5 A) and the additional current supplied by a parallel-connected voltage source may destroy the circuit.

With channels A and B connected in parallel, the voltage and current settings are best made according to the following example:

Assuming that a current-carrying capacity of 1.1 A is required at a voltage of 12 V, set channel A to a slightly higher voltage, say, 13 V and to full current. Set channel B to precisely 12 V. When current is drawn, channel A operates in the constant-current mode and channel B takes over voltage control.

### 3.7 Tracking of Channels A and B

When the TRACKING switch is in position ON, the two outputs of the channels A and B are internally connected in series and with respect to the connected centre terminals a positive (channel A) and a negative (channel B) voltage are available. If the positive voltage is changed (using the ten-turn potentiometer of channel A), the negative voltage of channel B is changed automatically by the same percentage. If the voltage potentiometer of channel B is at its right-hand stop, the two voltages are equal. By turning the potentiometer, the negative voltage can be adjusted to any portion of the positive voltage. The preset voltage ratio is maintained even if channel A should change to the constant-current mode. If channel B changes to the constant-current mode, this has no effect on the output voltage of channel A.

Note: A toggle switch with locked endstops is used as the TRACKING switch. To release the locking mechanism, pull out the lever and move it to the other position. This precaution ensures that the lever cannot be switched over inadvertently (e.g. when adjusting other front-panel controls), as this might produce undue output-voltage changes in channel B.

### 3.8 Thermal Protection

Both heat sinks for the power transistors of the regulating units carry thermal circuit breakers. These cut the AC supply of the unit off when the temperature of the heat sinks becomes too high. This, however, may occur only if several extreme conditions, such as permanent short-circuit with maximum current, AC supply overvoltage, high ambient temperature, coincide.

#### 4. Description

The forward characteristic of the power transistor (regulating unit) connected in series with the load is controlled such that either the output voltage is kept constant or the output current is limited, depending on the load connected to the unit. Both the effects of AC supply variations and of load variations are eliminated. The transition from voltage to current regulation and vice versa is automatic.

##### 4.1 Principle of Voltage Regulation

Voltage regulation (Fig. 1) is performed by a comparison of the actual value (output voltage of the unit) with the nominal value (reference voltage source) in a bridge circuit consisting of reference voltage source, programming resistor, setting potentiometer and output. The bridge is balanced when the reference voltage is in the same relation to the programming resistor as the output voltage to the potentiometer setting. Since the reference voltage and the programming resistor have fixed values, the output voltages must be strictly proportional to the value adjusted with potentiometer. With bridge unbalance, the voltage of the diagonal bridge arm is boosted in an operational amplifier and controls the regulating unit such that bridge balance is restored by variation of the output voltage.

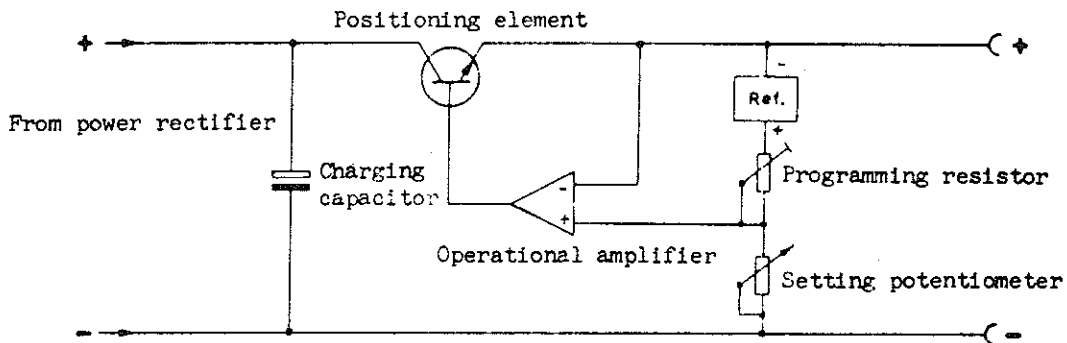

Fig. 1 Schematic of voltage regulation

## 4.2 Principle of Current Regulation

With current regulation (Fig. 2), the voltage drop caused by the load current across the current measuring resistor is compared with the part of the reference voltage tapped at the wiper of the setting potentiometer. The operational amplifier controls the regulating unit such that the two voltages are equal and zero voltage exists at the inputs of the operational amplifier. The voltage drop across the current measuring resistor and hence the output current by which it is caused assumes a value which is directly proportional to the potentiometer setting.

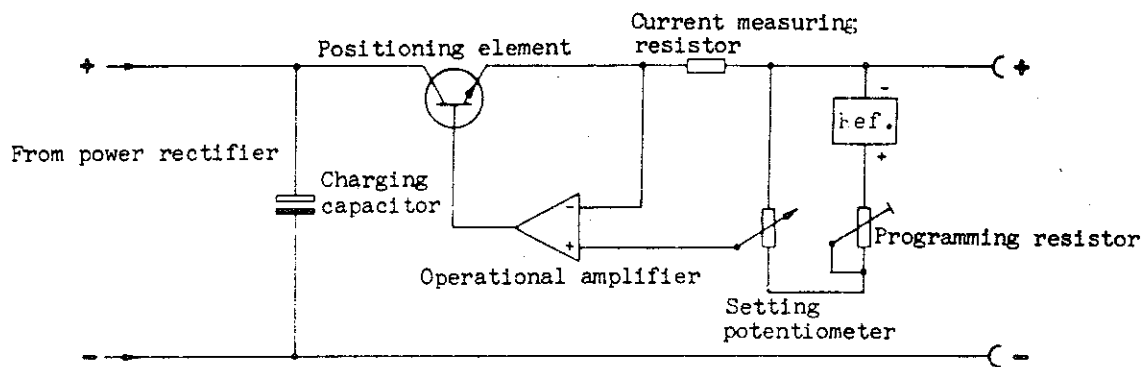
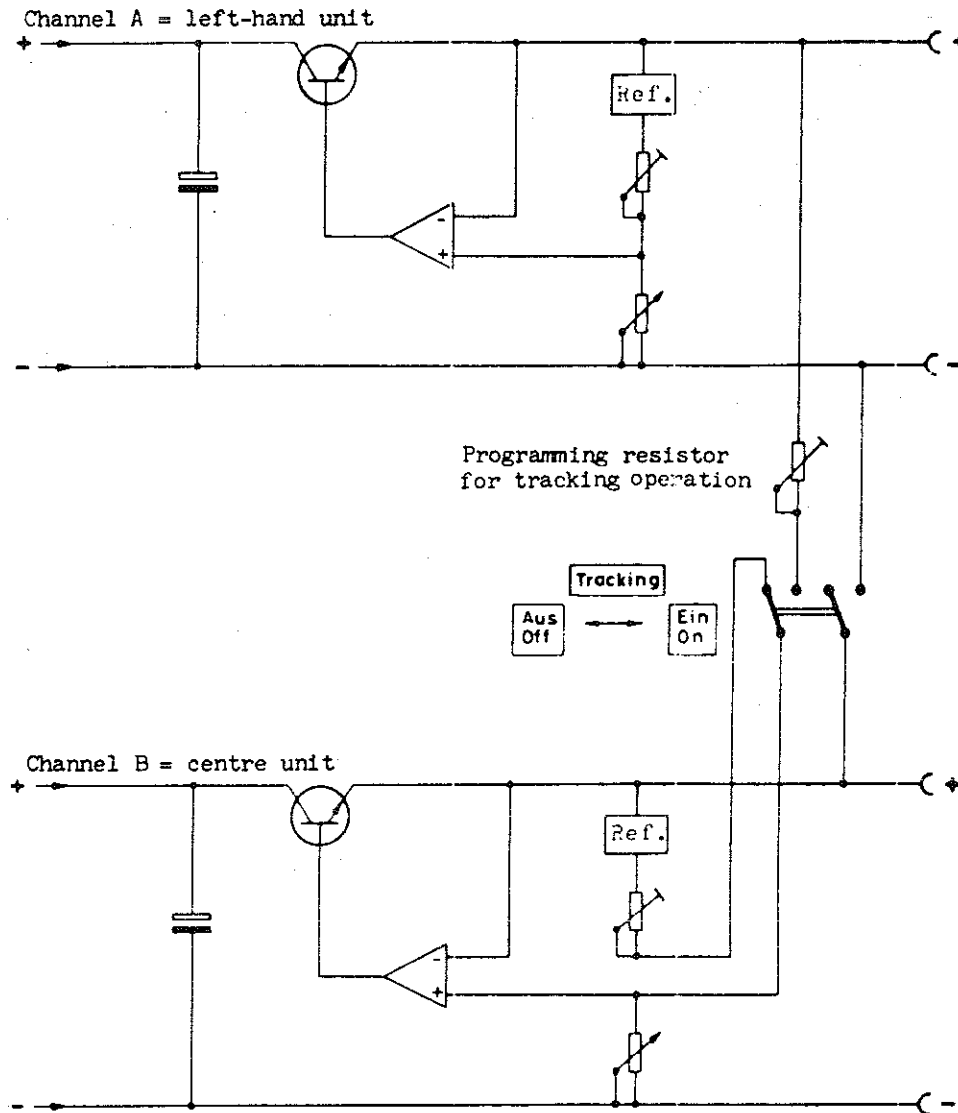

Fig. 2 Schematic of current regulation

## 4.3 Principle of Tracking Operation

In the TRACKING OFF position, channels A and B operate completely independent of each other according to the principle described in section 4.1 (Fig. 3). When the TRACKING switch is set to ON, the -terminal of channel A is connected to the +terminal of channel B, so that the output voltages are connected in series. The reference current source of channel B is cut off. It is replaced by the output voltage of channel A in conjunction with an additional programming resistor. Adjust the programming resistor such that the two output voltages are exactly equal if the two setting potentiometers have equal values (e.g. maximum at the right-hand stop). The output voltage of channel B can thus be influenced not only by the associated potentiometer but also by varying the output voltage of channel A.



**Fig. 3** Schematic of tracking operation of channels A and B

#### 4.4 Circuit Details

The following circuit description refers to channel B (see overall circuit diagram).

The AC voltage delivered from the secondary winding of power transformer Tr101 is rectified by diodes D201 to 204 and smoothed by the electrolytic capacitor C205. Capacitors C201 to C204 suppress any interfering pulses that may occur. The filtered DC voltage is applied to the regulating transistor T102, the current gain of which is increased by means of transistors T2 and T3 or T101 (channel C). Diode D5 protects the regulating transistors against reverse current. R20 is the current measuring resistor. Diode D7 protects the

output of the unit against the effects of wrong polarity if other voltage sources are connected (e.g. parallel operation).

The operational amplifiers and the reference-voltage source are fed from a secondary winding of the power transformer Tr101. This voltage is rectified and filtered with G1 1 and C2. Stabilized voltages of +15 V and -6.8 V are available at the output of the subsequent stabilizing circuit consisting of the integrated voltage regulator B1 and diode D2. The common centre point of these voltages is connected to the positive output terminal. The reference voltage for the voltage and current regulating circuits is derived from the +15-V source by restabilization in R19 and D6. The output voltages of the amplifiers B2 (voltage regulation) and B3 (current regulation) are added through R7 and R8 and applied to the regulating unit; via the switching transistor T1 they control the LED D101 for the indication of current limiting.

R9 constitutes a circuit load. The current flowing through it prevents the output capacitors C12 and C13 from being charged by the residual current of the regulating transistor T102 when the output is unloaded. Diode 4 reduces the positive supply voltage of the operational amplifiers B2 and B3 to +6.8 V.

R21 and R22 (UP) determine the programming current for the voltage potentiometer R101. Together with the current potentiometer R102, R23 and R24 (JP) form a voltage divider for the reference voltage. R25 and R26 (JM) determine the current measurement range of meter Ms101 and R27, R28 (UM) the voltage measurement range. R11 (U0) and R13 (JO) are used to adjust the initial voltage and initial current when R101 and R102 are set fully counterclockwise. The TRACKING switch S301 connects channels A and B in series. In the TRACKING mode, R101 of channel B obtains a reference current from the output voltage of channel A. This current is determined by R301 and R302. C9, C10 and C102 together with R15 to R18 isolate the operational amplifiers from RF which might penetrate into the set through the output terminals.

#### 4.5 Overvoltage Protection

(see circuit diagram)

Should an excessively high voltage occur at the output terminals, thyristor Th1 fires and shorts the output so that the unit changes to the constant-current mode. The residual voltage across the output terminals is reduced to a value which, as a result of the voltage drop across R13, depends on the set current limit. This residual voltage is, however, always below 2 V.

Transistor T1 acts as the threshold detector for the overvoltage protection circuit. T1 conducts when the voltage drop across R3/R5/R6 exceeds the base-emitter voltage. The current flowing through the voltage divider R1, R2, R3/R5/R6, R4 is determined by the voltage present across it; the desired voltage can be adjusted with R1. Transistor T1 conducts when this voltage is exceeded. Since T1 and T2 form a bistable multivibrator, T2 conducts as well so that T3 delivers the firing current for thyristor Th1.

To reset the overvoltage protection, the power supply must be switched off and the cause of the overvoltage eliminated. The unit can then be switched on again.

The capacitors C1 and C2 are provided to prevent unwanted fast response to pulse spikes. Should a fast response of the overvoltage protection be undesirable (e.g. with insensitive loads producing high pulse spikes) capacitor C3 (ca. 10 to 100 nF) can be additionally connected into circuit (mounting holes on PC board are provided). This, however, reduces the response speed of the overvoltage protection so that a rapid voltage rise (e.g. due to break-through of regulating transistor) may produce an increase in the output voltage.



## 5. Maintenance and Calibration

As a rule, the Power Supply does not require special maintenance. The panel meters and LED's on the front panel indicate the operational status.

Transistors can be replaced without recalibration. When, however, the reference-voltage sources (Z diodes D6) are replaced, the maximum output voltage and maximum output current require readjustment. Replacement of the IC's B2 and B3 should be followed by a check and, if necessary, readjustment of the initial voltage and initial current.

The following R&S instruments are recommended for performance checks and calibration:

- a) DC voltage measurement: Digital Multimeter UGWD
- b) Ripple and noise measurement: Microvoltmeter UVM  
Millivoltmeter UVN

Moreover, a DC ammeter with 1-A and 5-A ranges is required.

Before calibration, check the zeros of the meters when the unit is switched off and correct, if necessary. Then proceed as follows:

Caution Pull out the power plug before opening the cabinet. Remove the left-hand side plate and the bottom cover plate and connect the unit to the AC supply. Switch on and allow about 20 minutes for warmup without load. The trimming potentiometers are on the regulator board and are accessible from below through holes in the board.

### 5.1 Calibration of Output Voltage and of Voltage Indication

The same calibration is to be made for each of the three channels.

- a) Set TRACKING switch to OFF, INSTRUMENT switch to V.
- b) Connect a digital voltmeter or differential voltmeter to the output of the channel concerned.
- c) Set the VOLTAGE potentiometer fully counterclockwise. Check for coincidence with the zero of the scale.
- d) Adjust for < 10 mV output voltage using the trimming potentiometer R11 (on printed side of PC board, marked U0).
- e) Adjust the VOLTAGE potentiometer such that after precisely 10 turns the mark on the knob coincides with the zero of the scale.
- f) Adjust for nominal output voltage using the trimming potentiometer R22 (marked UP).

- g) Adjust for full-scale deflection on the meter using the trimming potentiometer R28 (marked UM).

### 5.2 Calibration of Output Current and of Current Indication

The same calibration is to be made for each of the three channels.

- a) Set TRACKING switch to OFF, INSTRUMENT switch to A.
- b) Short the output via an ammeter.
- c) Set the CURRENT potentiometer fully counterclockwise.
- d) Adjust for  $< 10$  mA output current using the trimming potentiometer R13 (marked JO).
- e) Set the CURRENT potentiometer fully clockwise.
- f) Adjust for nominal output current using the trimming potentiometer R24 (marked JP).
- g) Adjust for full-scale deflection on the meter using the trimming potentiometer R28 (marked JM).

### 5.3 Calibration for Tracking Operation

- a) With the TRACKING switch in position OFF, calibrate channels A and B according to sections 5.1 and 5.2.
- b) Remove the left-hand side plate. The trimming potentiometer R301 located on a small PC board under the TRACKING switch is then accessible.
- c) Set the TRACKING switch to ON.
- d) Set both INSTRUMENT switches to V.
- e) Adjust both VOLTAGE potentiometers according to 5.1 e).
- f) Check the output voltage of channel A (nominal) with a digital voltmeter and adjust channel B to exactly the same output voltage using the trimming potentiometer R301.

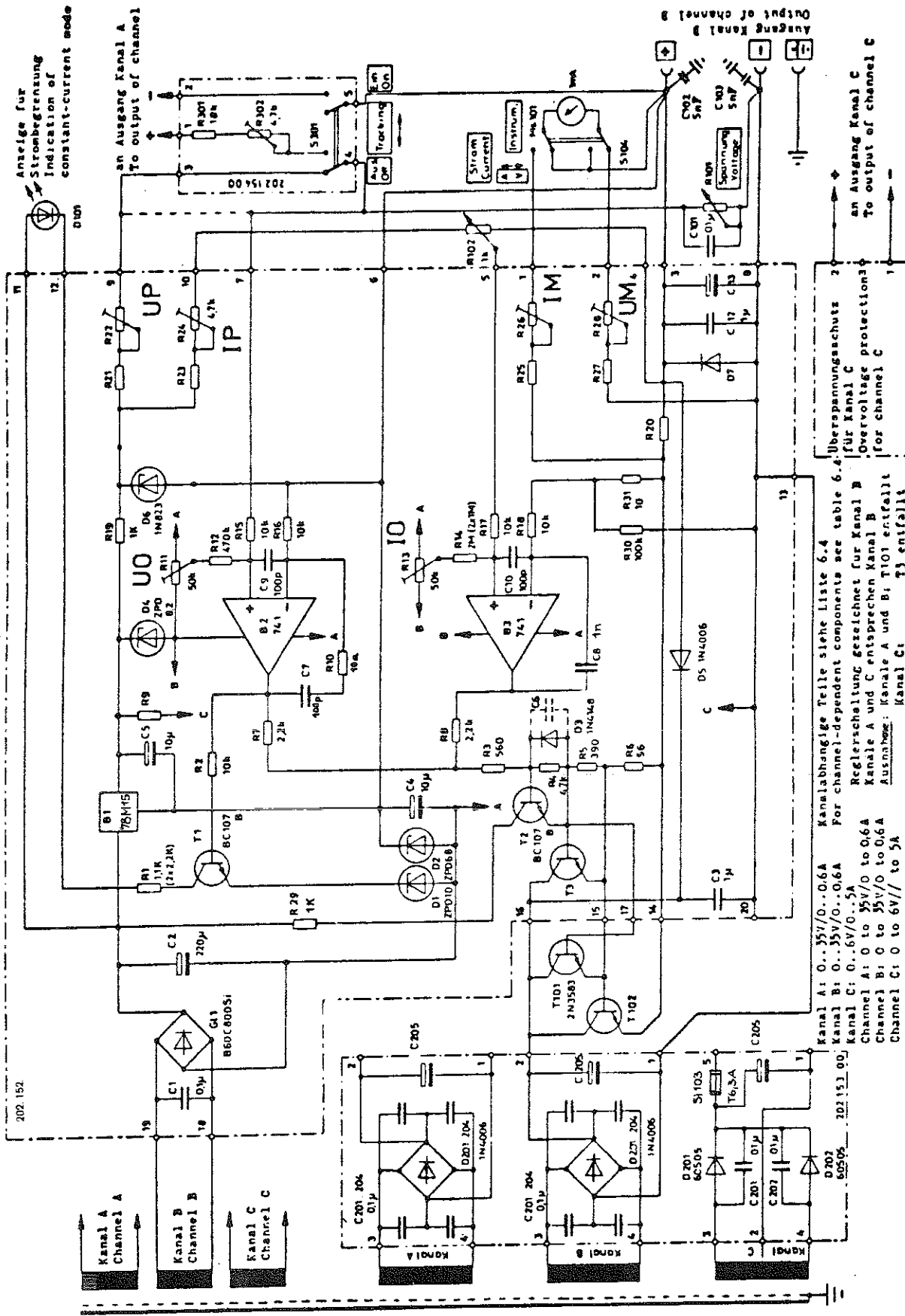

6.1 Gesamtstromlauf  
6.1 Overall circuit diagram

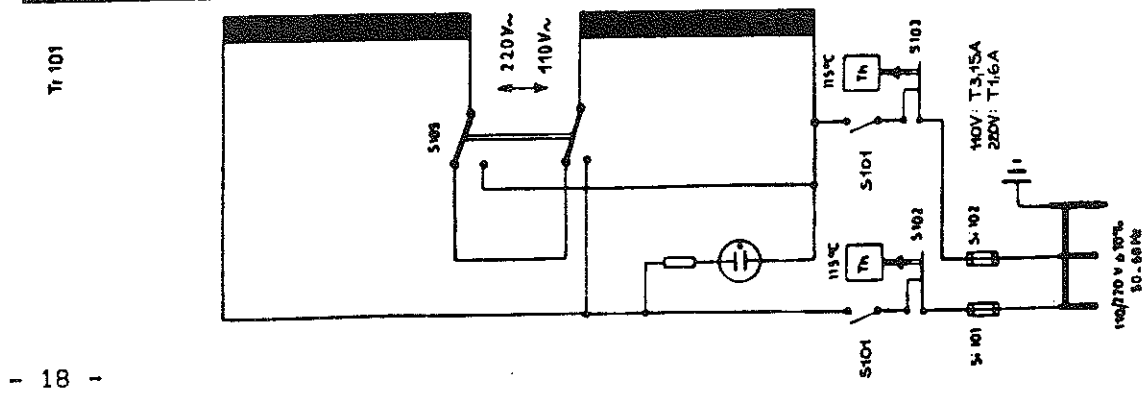

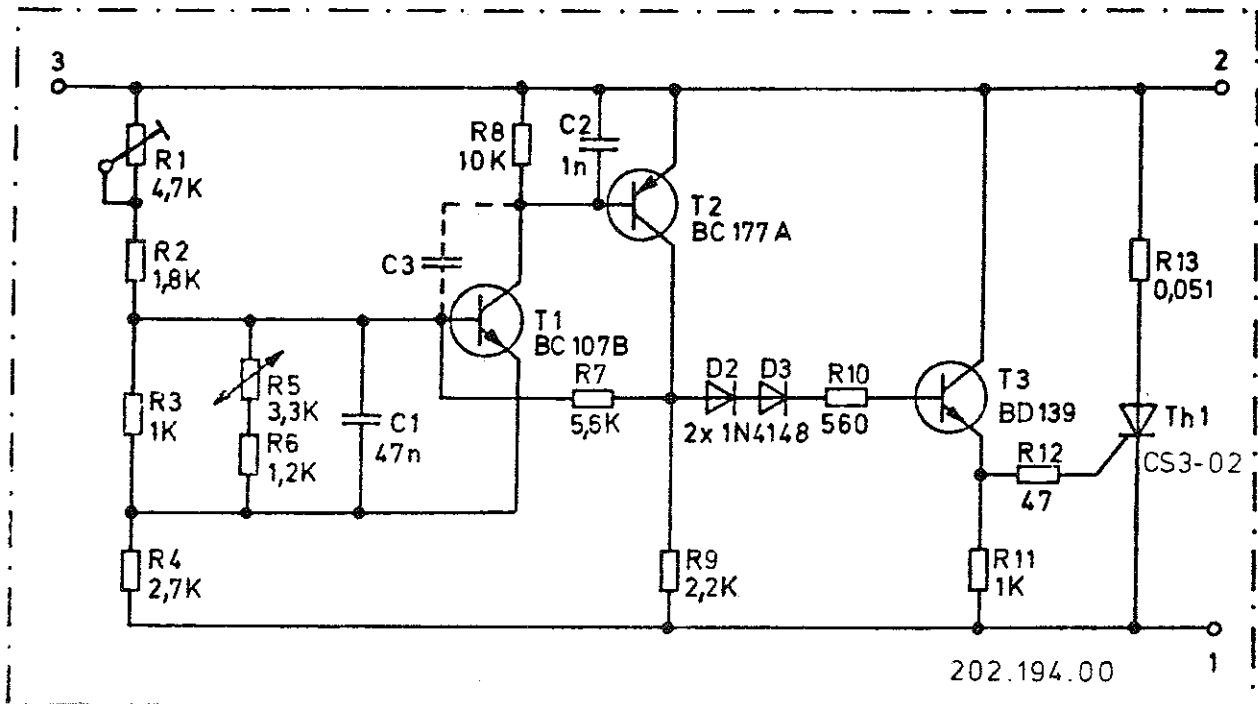

6.2 Stromlauf Überspannungsschutz  
 Circuit diagram of overvoltage protection

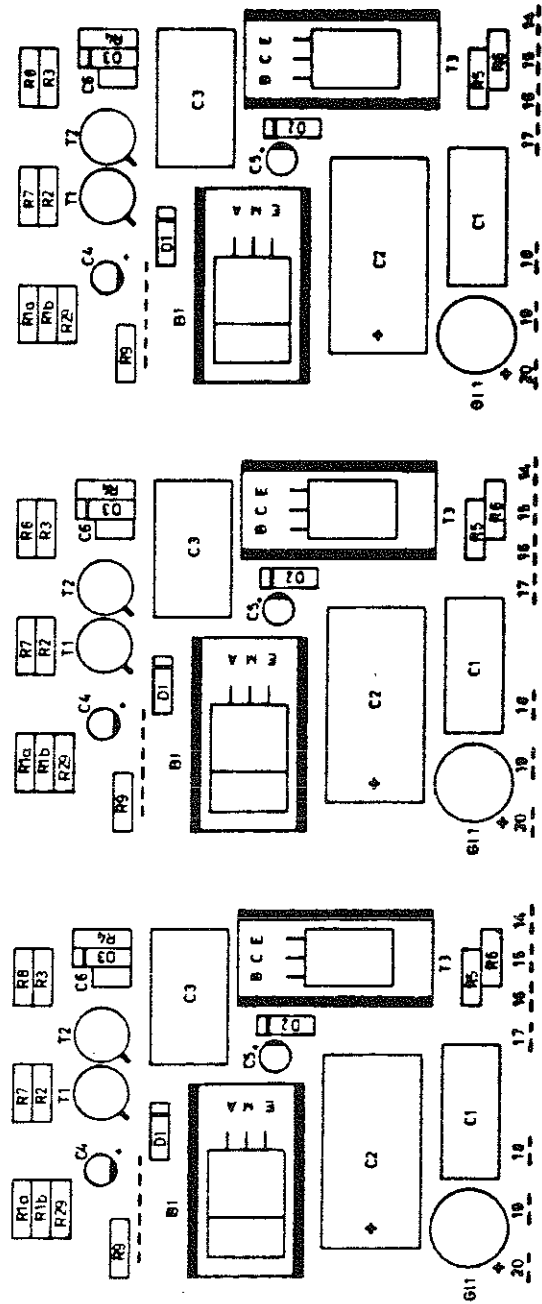
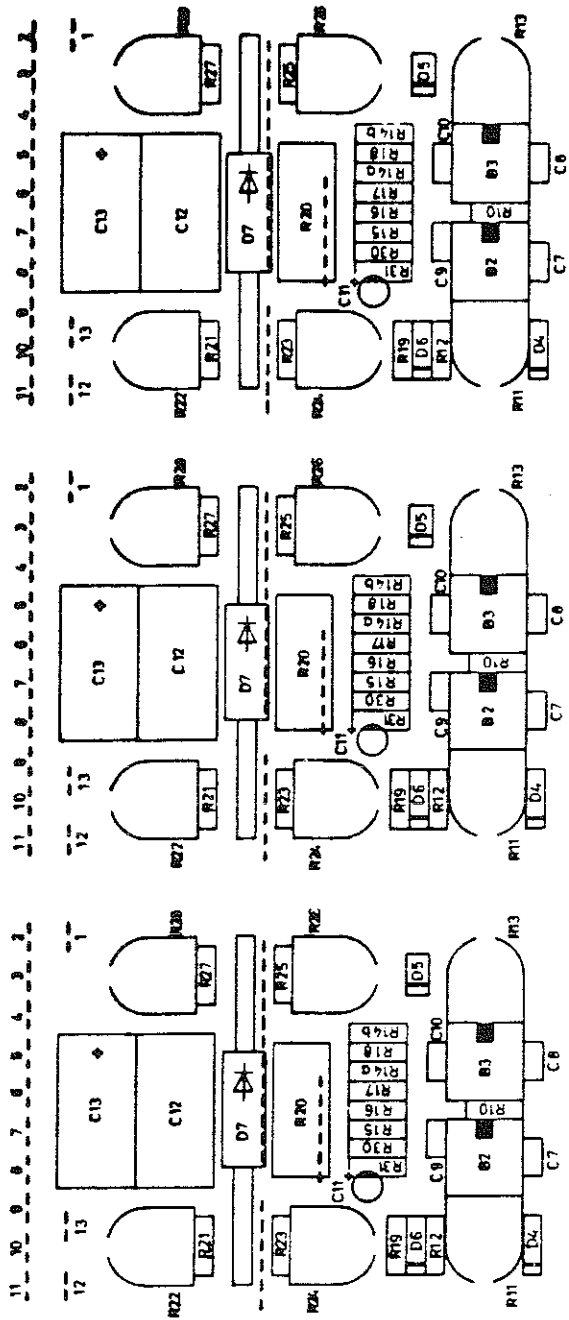

6.3 Bestückungsplan Reglerplatte  
 Components plan of regulator board

Pos.	Kanal A und B Channel A and B (NGT 20)	Kanal A und B Channel A and B (NGT 25)	Kanal A und B Channel A and B (NGT 35)	Kanal C Channel C
C13	100 $\mu$ F/40 V	100 $\mu$ F/40 V	47 $\mu$ F/63 V	470 $\mu$ F/10 V
C205	4700 $\mu$ F/40 V	3300 $\mu$ F/63 V	3300 $\mu$ F/63 V	2200 $\mu$ F/16 V
D7	BY 251	BY 251	BY 251	21 PT 20
D201	1 N 4006	1 N 4006	1 N 4006	60 S 05
D202	1 N 4006	1 N 4006	1 N 4006	60 S 05
D203	1 N 4006	1 N 4006	1 N 4006	-
D204	1 N 4006	1 N 4006	1 N 4006	-
R9	15 kOhm	15 kOhm	22 kOhm	10 kOhm
R20	0,51 Ohm	0,51 Ohm	0,91 Ohm	2 x 0,24 Ohm
R21	5,1 kOhm	3,9 kOhm	3,3 kOhm	9,1 kOhm
R22	2,2 kOhm	2,2 kOhm	470 Ohm	2,2 kOhm
R23	10 kOhm	12 kOhm	8,2 kOhm	8,2 kOhm
R25	360 Ohm	270 Ohm	390 Ohm	390 Ohm
R26	100 Ohm	100 Ohm	220 Ohm	220 Ohm
R27	18 kOhm	22 kOhm	33 kOhm	5,6 kOhm
R28	4,7 kOhm	4,7 kOhm	4,7 kOhm	1 kOhm
R101	20 kOhm	20 kOhm	20 kOhm	10 kOhm
T3	BD 135	BD 135	BD 137	omitted
T101	omitted	-	omitted	2 N 3583
T102	2 N 3055	2 N 3055	2 N 3055	2 N 3771

6.4 Liste der kanalabhängigen Bauteile  
Table of channel-dependent components