

OPERATING INSTRUCTIONS FOR THE "UNIVERSITY" MODEL TVT VALVE TESTER AND THE TST/2 VALVE AND CIRCUIT TESTER.

GENERAL

This instrument has been developed to fulfil the requirement of a completely flexible method of testing modern radio and television valves. It incorporates lever switches for element selection, which enables it to test any future types of valves regardless of their base connections.

A masking plate covers three spare socket holes in the front panel to enable additional sockets to be fitted should new types come into use.

The principle of testing conforms to standard RMA practice

CONTROLS

"LINE" This control is situated in the bottom left hand corner of the front panel and its purpose is to compensate for varying line voltages.

FILAMENT VOLTS "A" Filament volts are selected for the valve under test by two switches, which are situated next to the "LINE" switch on the bottom of the front panel. The filament voltages available are from 0.6 to 117, the first switch selecting up to 12.6 volts and second switch the higher voltages.

To obtain filament voltages above 12.6 it is necessary to turn the first filament switch to "HIGH VOLTS", then the second switch is set to the voltage required. Until the first is in the "HIGH VOLTS" position the second switch is inoperative.

ELEMENT SELECTOR "B-C-D" The element selector takes the form of ten lever switches, numbered from 1 to 10. Each of the switches from 1 to 9 represents the pins of a valve, the number above each switch from 1 to 9, corresponding to the pin numbers of the valve, according to standard valve numbering practice, and switch 10 represents the "TOP CAP".

This form of switching enables the tester to switch any valve connection to any test position, or in the case of a valve having an internal connection or tapped heater to completely isolate a valve pin.

The letters "B", "C" & "D" refer to the test positions to which valve elements may be switched. These test positions are given in the valve testing tables.

When the lever switches are in the "NORMAL" position they are connected together to one side of the heater voltage. Normally all elements are left in this position with the exception of the element nearest the cathode and one heater connection.

Position "B" is the heater connection and one heater pin is switched to this position.

Position "C" is an open circuit position and any valve pin which has an internal connection which may tend to interfere with testing is switched into this position.

Position "D" This is the "TEST" position. The element which is nearest to the cathode inside the valve is switched into this position and the tester applies a voltage to it for emission testing. Results are indicated directly on a three coloured scale marked good, questionable and bad.

TEST SELECTOR "E" This switch is situated fourth from the left on the bottom of the front panel, and its purpose is to select the test function required.

When switched to "LINE", the meter indicates line voltage, and the "LINE" switch should be set to a position to make the meter pointer reach the arrow at full scale deflection.

This test should be carried out with the valve under test in position.

In the "SHORTS" position the instrument will indicate shorts between any elements in the valve under test. To enable selection of shorts which may only occur when the cathode is heated, after applying filament voltage to the appropriate pin, the heater will warm up and each remaining lever switch in turn may be moved to the "TEST" position. The neon lamp will then indicate any continuous path between elements in a tube. When the levers corresponding to the second or other filament connections are operated, the lamp should light, indicating filament continuity. So this will not be mistaken for a short circuit, the levers corresponding to other filament connections are indicated at the left hand side of the column marked "SHORTS INDICATION" in the data sheets. Some modern tubes have one or more internal connections linking certain base pins. In order that these may be distinguished from actual short circuits, the number of any levers which should produce a glow in the neon lamp are also listed in the "shorts indication" column. Should the lamp glow when levers other than those listed in this column are moved to the "TEST

POSITION" a short circuit exists in the valve and no attempt should be made to apply and emission test.

The position "1","2" and "3" of switch "E" are the test positions for emission, and in general position "1" tests diode plates and small battery valves with limited emission and TV picture tubes. Position "2" tests all general purpose R.F. pentodes, tetrodes, triodes etc., and position "3" all power valves and power rectifiers.

RANGE "F" The range potentiometer is situated in the bottom right hand corner of the front panel and its function is to correctly adjust the meter sensitivity. So that average new valves cause the pointer to register near the right hand end of the "GREEN" portion of the meter scale, valves which are better than average may cause the needle to read full scale deflection or move slightly beyond the green segment.

TOP CAP The top cap lead supplied with the instrument is plugged into socket marked "TOP CAP" and is connected to those valves fitted with caps, prior to testing.

TESTING PROCEDURE

- 1) See that all lever switches are in the "NORMAL" positions.
- 2) FILAMENT VOLTS Switch "A" to correct voltage as shown in column "A" of valve tables.
NOTE: For voltages exceeding 12.6, the left hand "A" switch must be turned to "HIGH VOLTS".
- 3) Determine from "B" column in valve tables the pin number for one of the filament connection and move correspondingly numbered lever switch to "B" filament position.
- 4) Plug valve to be tested into appropriate socket.
- 5) Set "E" switch to "LINE" and adjust "LINE" switch to set meter pointer to arrow at full scale deflection.
- 6) Set "E" switch to "SHORTS" and test for shorts by setting each lever switch in turn to "D" "TEST" position, returning each switch to "NORMAL" after observing whether or not the lamp lights. It is not necessary to move the lever already in the "B" "FILAMENT" position

The lamp will normally glow when a lever corresponding to the second end of the filament or a filament tap is brought to the "TEST" position. To distinguish the normal glow indicating the filament continuity from a short circuit, base pins corresponding

to filament connections which should produce a glow are listed on the left hand side of shorts indication of the chart.

7) Refer to column "D" of valve tables and throw corresponding lever to "D" "TEST" position.

8) Set control "E" to position "1", "2" or "3" as indicated in "E" column in valve table.

9) Advance control "F" to number indicated in "F" column and observe condition of valve on meter scale.

10) Remove valve and return controls to "NORMAL" or off.

NOTE: To avoid any chance of danger to meter it is important that valve is removed before the lever switched to "B Filament" is returned to "NORMAL".

In the case of centre tapped heaters the lever corresponding to the centre tap should be used and voltage should be that applicable to parallel operation of the heater valves.

TESTING NEW TYPE VALVES (not shown on chart)

1) Set FILAMENT VOLTS to correct position for valve as determined from published data books.

2) Select one heater pin and switch lever switch corresponding to this pin to "B FILL" position.

In the case of centre tapped heaters the lever corresponding to the centre tap should be used and the voltage should be that applicable to parallel operation of the heater halves.

3) Plug in valve and adjust "LINE" switch.

4) Set "E" switch to shorts and carry out shorts test in the normal manner by setting each lever switch in turn to "D TEST" position.

Base connections in a valve data book will reveal any internal connections which should produce an indication.

5) The emission can be tested by determining from a valve data book the lever switch with the number corresponding to the element closest to the tubes filament or cathode.

In all ordinary types of tubes this will be the control grid. In frequency changers it will be the oscillator grid and in diodes and rectifiers, it will be the diode plates.

6) Switch "E" should be set to position 1 for diodes, to position 2 for all battery tubes and for ordinary A.C. operated amplifying tubes, and to position 3 for A.C. operated power output tubes and rectifiers.

7) Slowly advance "F RANGE" control to a position to give a "GOOD" valve reading on the meter scale. This setting should be obtained with a valve known to be good and recorded for future use.

8) Remove valve, then return all switches to "NORMAL".

NOTE.

Television picture tubes and EHT rectifiers may be tested in the model TVT or TST/2 for filament continuity, internal short circuits and electron emission from the cathode, like any other tube. This will show up the majority of faults which develop in these types of tubes.

The presence of any appreciable amount of air or gas within the envelope will be indicated by a low emission reading.

It is possible with these tubes however, that slight traces of gas may not reduce the emission reading but yet may ionise under the stress of the high voltage of the order of 14,000 to 18,000 volts present in a television receiver.

If an EHT rectifier or picture tube shows a defect when tested then the tube is definitely faulty. If it gives a "good" indication, it is wise to check in a television receiver in case of gas content.

E.H.T. Rectifiers.

E.H.T. Rectifiers are designed to pass very low plate current only usually about 0.5 ma so that even a good tube will only cause the needle to move between 25% and 40% of the way across the scale with the range control "F" set to 100. It is important to set switches A, B and C before inserting tube in socket.

PICTURE TUBES.

The TVT Picture tube adapter is intended for use with the Model TST/2 and the Model TVT valve tester and it is to be used in accordance with the operating instructions for these instruments.

This adapter, when used with the TST/2 and the T.V.T. will test all duo-decal based picture tubes for heater continuity, emission and short circuited elements. The TST/2 and the TVT do not illuminate the screen of a picture tube under test.

TST/2 MULTIMETER SECTION.

The Multimeter facilities of this instrument have a wide range of applications. It will measure voltage, current and resistance values accurately, and the design incorporates an efficient output meter. Following is a description of how the various sections are used. There are further and wider applications for this instrument which will manifest themselves as the operator becomes more familiar with the Multimeter.

Unless the operator understands the voltage and current readings of various circuits, it is advisable to always use the highest range available to obtain an approximate reading, and then choose a lower range which will be more suitable for an accurate reading. This will prevent damage to the meter from excessive overload.

D.C. VOLTAGES

Turn the central selector switch to the desired voltage range and make sure that the right-hand switch is turned to that position marked "D.C." The negative, or black, test lead is inserted in the negative jack on the instrument, and the red test lead is inserted in the positive jack. The two test prods are then touched to the necessary parts of the apparatus under test, and the meter will read the difference in potential between the two points touched, which is actually the voltage. It is necessary to remember that voltage is the difference in potential between any two points.

If it is desired to measure the voltage on the elements of a valve, the metal chassis of a radio receiver or amplifier is usually regarded as forming the negative side of the circuit. For instance, if it is desired to measure the plate voltage of a valve, the appropriate range would be selected, the positive test lead placed on the plate contact of the valve, and the negative test lead placed on the chassis. The meter would then read the valve's plate voltage. This method does not apply to the measurement of negative grid bias.

To measure the negative grid bias, the negative test prod is placed on the grid and the positive test prod is placed on the negative filament or cathode contact. The negative bias will then be indicated on the meter. This method will be inaccurate if a high value of resistance is included in the grid circuit, such as a resistance capacity coupled stage. In this case, the negative test prod should be placed on the end of the grid leak resistor, which does not connect to the grid.

When making voltage measurements, it is not necessary to remove or disconnect any wires.

A.C. VOLTAGES

To measure alternating voltage, the only rearrangement of the controls on the instrument is to turn the right-hand switch to that position marked "A.C." The appropriate voltage range is then selected in the ordinary way on the range selector switch, and the test prods, when plugged into the instrument, can then be connected to the two points between which it is desired to measure the voltage difference. Since alternating voltage has no fixed negative or positive potential, the negative or positive test lead from the instrument can be placed on either of the two points which are under test. However, to form a safety habit, it is always wise to place the negative lead on the low potential side of the circuit or that side of the A.C. voltage which is connected to earth. If this is inconvenient, the operator need not worry any further.

When measuring alternating voltages on the 10-volt range, the lowest meter scale, marked "10 V. A.C. only" should be used. When using 50,250 and 1,000 V. ranges, measurements should be made on the upper set of voltage graduations.

D.C. CURRENTS

In making current measurements, it is necessary to break the circuit and insert the test leads so that the meter is placed in series with the circuit. For instance, to measure the plate current of a tube, the wire on the plate contact would be removed and connected to the positive side of the meter. The negative meter lead would be connected to the plate contact and the selector switch would be turned to the desired range, and then the set switched on. The plate current of the valve would be registered on the meter. This procedure also applies to any other circuit in which it is desired to measure current in milliamperes. The circuit is simply broken and the meter inserted in the break to complete the circuit again.

Where the current value is unknown, it is always wise to commence on the highest range, and then turn the selector switch down to that range which give the most convenient deflection of the needle on the meter.

A.C. CURRENTS

The TST/2 by itself is only intended to measure alternating (A.C.) current on the 1mA range, in which case the upper voltage graduations are used. This range can be extended by using the MRCT "University" current transformer which is available as an extra. The MRCT needs no soldered connections it simply connects by terminals to the TST/2 and a switch on the MRCT selects the

desired A.C. current range. It extends the TST/2 to read the following A.C. current:-

2.5, 5, 10, 25, 50, 100, 250 and 500mA A.C. and 1, 2.5, 5 and 10 amperes A.C.

RESISTANCE

This instrument will measure values of resistance in four convenient ranges:- 0-1,00 ohms, 0-10,00 ohms, 0-100,000 ohms and 0-10 megohms.

To measure values of resistance below 1,000 ohms, the selector switch is turned to the position marked "R X 1." The test leads are inserted in the instrument and then the test prods are touched together so that the meter needle will swing right over to the position marked "0" on the upper meter scale. If it does not exactly reach the "0" mark on the ohms compensator at the left hand side of the instrument is turned until the needle indicates zero resistance. The meter is then ready for use.

To measure resistance one side or both of the resistance or other part should be disconnected from the rest of the circuit and the test prods placed on its terminals. The value of resistance will be shown on the ohms range.

For values up to 10,000 ohms the switch is turned to the position marked "R x 10" and the scale figures must be multiplied by 10 to give the correct resistance. For example if you are measuring a resistance of 4,000 ohms and the switches are turned to the correct position then the meter needle will indicate 400. Multiplying this by 10 gives 4,000 which is the correct reading assuming that the resistor is in good order.

When measuring in the range of 10,000 ohms, it is necessary that the prods are touched together again and the needle adjusted for zero resistance by use of the ohms compensator.

For values up to 100,000 ohms the range switch is turned to the position marked "R x 100" and the procedure is carried out as explained previously. For measurements up to 10 megohms turn switch to "R x 10,000" and proceed as before. When using the "R x 10,000" range the instrument must be connected to power mains.

In measuring resistance it is necessary that the right hand switch be turned to the position marked "D.C." Always before measuring resistance make certain that the test prods are touched together and the ohms compensator adjusted so the meter reads zero before operation. The purpose of this ohms compensator is to compensate for any variation in battery-voltage which will enable you to obtain a maximum life from the built in battery.

CAUTION - Before attempting to measure the resistance of any part of radio or electrical apparatus, be sure to switch off the power or to disconnect one wire from each battery in the case of battery-operated equipment.

OUTPUT METER

In addition to measuring ordinary A.C. voltages over a wide range the Multi-meter can also be used as an output meter the right hand knob on the instrument is turned to the position marked "OP" and the range selector is turned to an appropriate voltage and "DB" range. The test leads are inserted in the instrument, and one lead is attached to the chassis while the other lead is touched to the plate of the output or power valve in the receiver or amplifier under test.

Small push-on clips are provided with the instrument. These easily and conveniently fit on the test leads, so that it will not be necessary for the operator to hold these on to the point under check in the chassis. They can be clipped on to any convenient wire or terminal leaving the operator's hands free for alignment of the set.

If the range selector is turned to 10 volts when using this as an output meter, it will give a very sensitive reading, However, it will be found necessary for the volume of the receiver to be kept low, so as not to damage the meter. This 10-volt range is recommended for aligning sets. If the output meter is required for a purpose other than alignment, the 50-volt or 250-volt will be found quite suitable.

Used in this manner, the instrument will facilitate the alignment of a receiver, especially when a modulated oscillator or signal generator is used as the source of signal.

The meter scale is also calibrated in db. When using db ranges, the figure indicated by the Selector Switch must be added to that indicated by the meter pointer.

BATTERY REPLACEMENT

The resistance measurement section of this instrument utilises a standard 1.5-volt 950 dry battery cell, for the ranges R, R X 10 and R X 100. This usually lasts up to twelve months without replacement. It will be known when the battery is due for replacement by the fact that the ohms compensator on the panel will not enable the pointer of the meter to be brought right to the zero mark. The R X 10,000 range is powered by rectified A.C. furnished from the valve testing section.

GENERAL

The primary purpose of this instrument is to measure D.C. voltage, currents and resistances, as well as A.C. voltages and output voltages. The instrument is accurate and is easily portable.

It will cover nearly all of the routine checking required in a radio receiver, and in general radio equipment. It must be remembered that voltage measurements in a receiver will not only indicate that there is voltage available, but if they are measured through any of the components in the receiver, they will indicate whether that component is open circuit or otherwise by the indication of voltage on the meter. Faulty and intermittent transformers can be tested by using the ohms section of the instrument, and continuity test on all components can be made with this section. The instrument will also indicate short circuits and open circuits, leaky condensers, faulty resistance, broken connections and incorrect values. The output meter section can be used to indicate a standard of output from apparatus under test, and constant use of the instrument will bring many new suggestions to mind.

The meter needle should normally coincide exactly with the zero end of the voltage and milliamp scales when the meter is not in use. Should it not do so, it can be adjusted to zero by means of the large bakelite screw on the face of the meter, just below the glass.

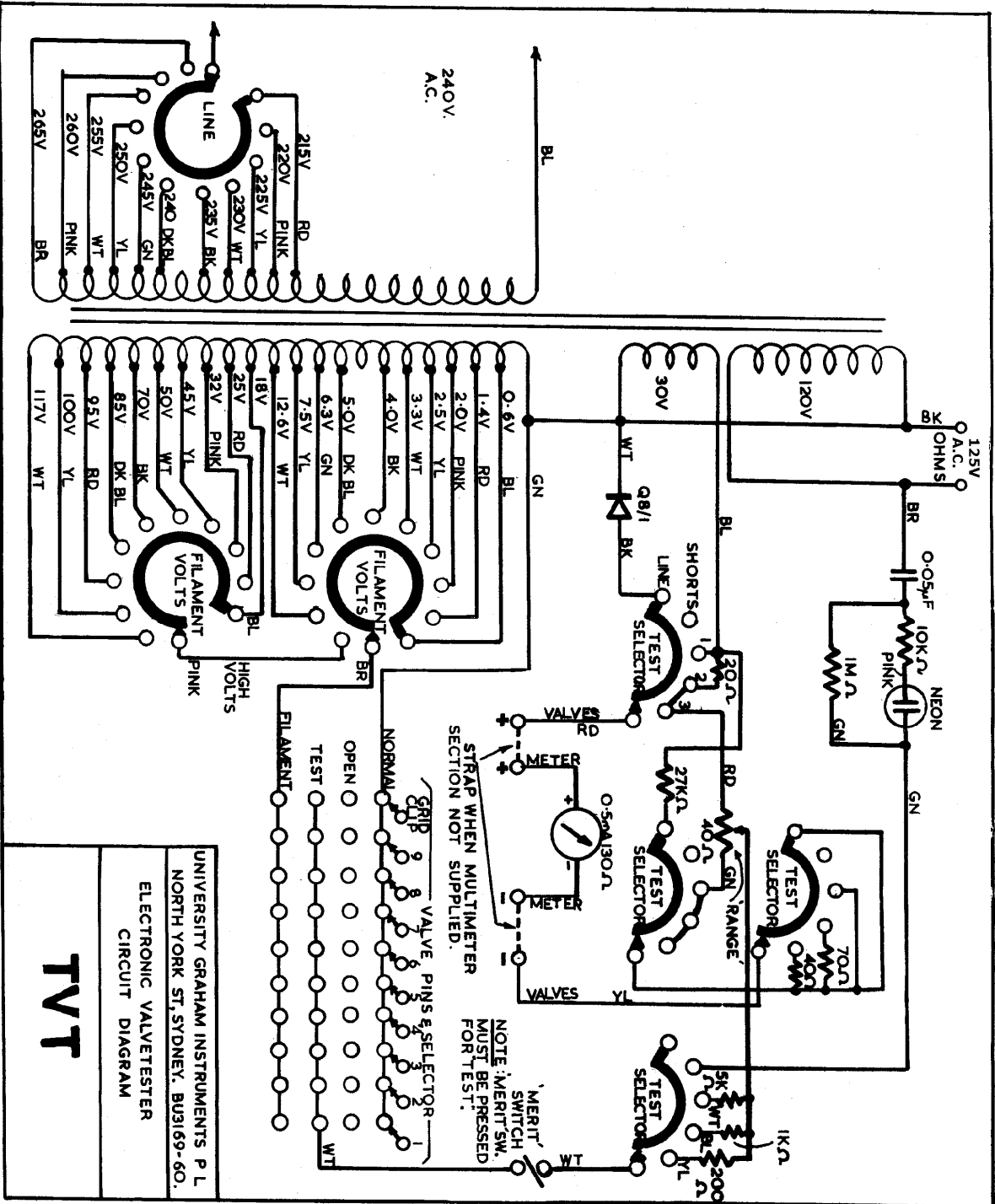

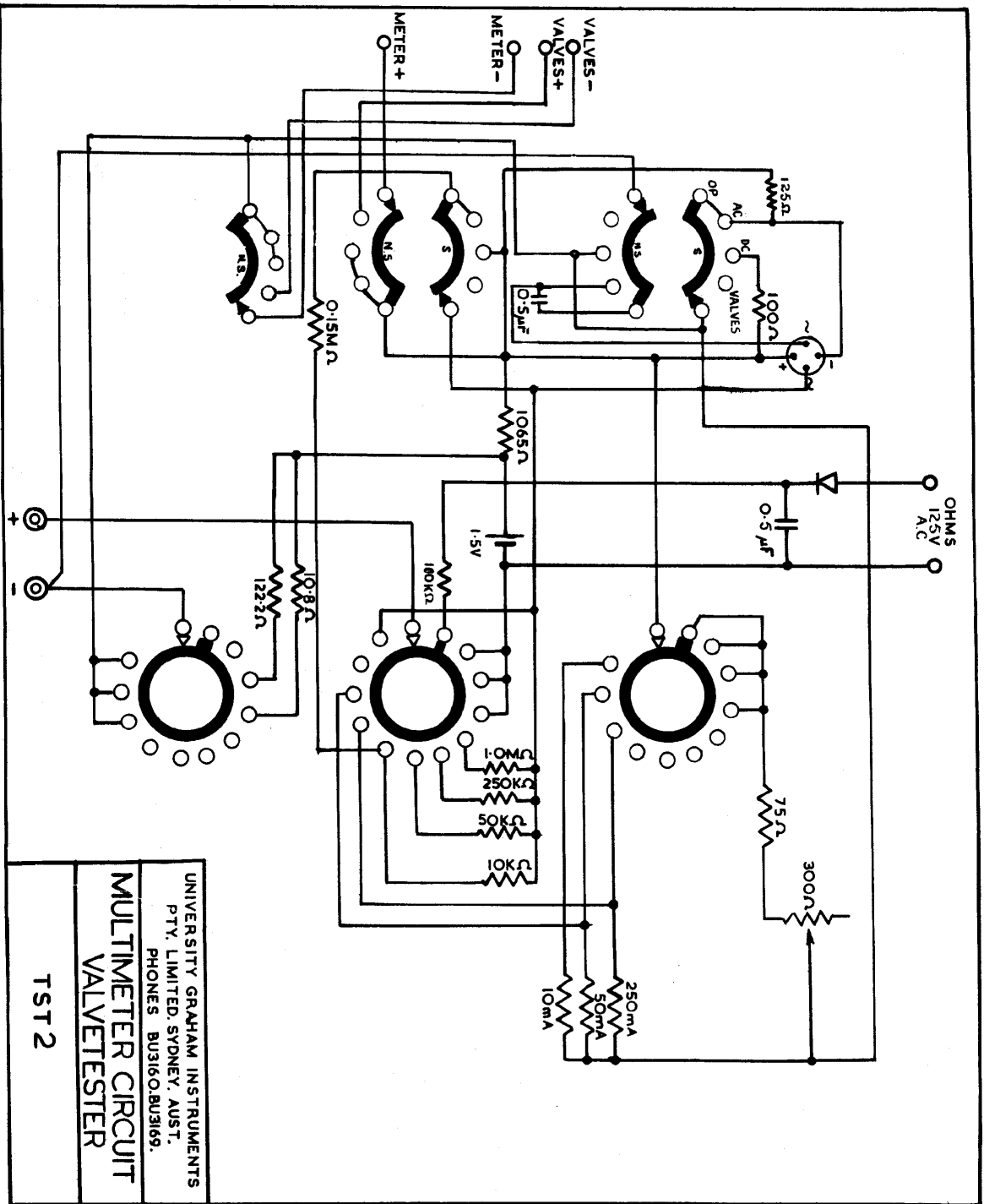

UNIVERSITY GRAHAM INSTRUMENTS
 PTY. LIMITED, SYDNEY, AUSTRALIA
 PHONES BU3160, BU3169.

MULTIMETER CIRCUIT
 VALVETESTER
 TST 2