



## RETURN POLICY

PRODUCTS CANNOT BE RETURNED WITHOUT DIRECT APPROVAL OF THE SUTTER INSTRUMENT COMPANY.

ALL SHIPMENTS RETURNED FOR CREDIT OR EXCHANGE, WHEN THE ERROR IS NOT DUE TO SUTTER INSTRUMENT COMPANY, WILL BE SUBJECT TO A 15% RESTOCKING CHARGE WITH A MINIMUM CHARGE OF \$5.00.

PLEASE RETAIN ALL PACKAGING MATERIALS UNTIL PRODUCTS HAVE BEEN INSPECTED AND HAVE PROVEN SATISFACTORY. THIS WILL INSURE THAT THE GOODS RETURNED TO US WILL BE PACKAGED IN A SAFE AND PROPER MANNER. FAILURE TO RETURN GOODS WITH PROPER PACKAGING MAY RESULT IN THE GOODS BEING DAMAGED IN TRANSIT. WHEN GOODS ARE DAMAGED DUE TO CUSTOMER'S FAILURE TO PACKAGE THEM PROPERLY, THE CUSTOMER WILL BE INVOICED FOR THE DAMAGED GOODS, OR THE REPAIR COST.

ALL GOODS MUST BE RETURNED WITH SHIPPING CHARGES PREPAID, NO C.O.D OR BILL RECIPIENT SHIPMENTS WILL BE ACCEPTED.

ITEMS RETURNED FOR CREDIT OR EXCHANGE CAN ONLY BE RETURNED WHEN THE ITEM HAS BEEN AT THE CUSTOMERS ADDRESS FOR LESS THAN 15 DAYS, UNLESS PREVIOUS ARRANGEMENTS HAVE BEEN MADE.

# SUTTER INSTRUMENT COMPANY

## ACCESSORY PRICE LIST

FOR MODEL NO.	ITEM	CATALOG NO.	PRICE
P-77B, P-80C PC-84, P-80/PC	3mm Square Box Filament 3mm Wide	FB330B	\$ 9.75
For tubing greater than 1.2mm O.D.	3mm Square Box Filament 2mm Wide	FB320B	9.75
	3mm Square Box Filament 1.5mm Wide	FB315B	9.75
For tubing 1-2mm O.D.	2.5mm Square Box Filament 2.5mm Wide.	FB255B	9.75
	2mm Square Box Filament 3mm Wide	FB230B	9.75
For tubing 1.2mm O.D. and less	2mm Square Box Filament 2mm Wide	FB220B	9.75
	2mm Square Box Filament 1.5mm Wide	FB215B	9.75
	4.5mm Wide Trough Filament	FT345B	9.75
	3.0mm Wide Trough Filament	FT330B	9.75
	1.5mm Wide Trough Filament	FT315B	9.75
	Platinum Iridium Sheet for User Fabrication, 18mm x 75mm, 0.002" thick	FS1875	90.00
P-77A	2.5mm Loop Filament	FL325A	9.75
For P-77A Ser. # 160 and above	2.0mm Loop Filament	FL320A	9.75
	1.5mm Loop Filament	FL315A	9.75
P-77	2.5mm Loop Filament	FL325X	9.75
	2.0mm Loop Filament	FL320X	9.75
	1.5mm Loop Filament	FL315X	9.75
P-77, P-77A	Loop Forming Tool	FF00XA	5.00
	Nitrogen Tank (full)	NT0XAB	130.00
	Instruction Manual	IM0XAB	15.00
P-77, P-77A	Kit to convert P-77 and P-77A to Model B Trough and Box Filament System	BK00XA	300.00

ORDER FROM: SUTTER INSTRUMENT COMPANY  
P.O. BOX 3592  
SAN RAFAEL, CA 94912  
Phone: (415) 459-7327  
Telex: 6503036228  
Answer Back: 6503036228 MCIUW

Sutter Instrument Company reserves the right to change or modify prices and/or specifications at any time.

Effective 11/1/86

# SUTTER INSTRUMENT COMPANY

2169 FRANCISCO BLVD., SAN RAFAEL, CA 94901  
PHONE: (415) 459-7327 TELEX: 6503036228 MCI UW

---

## SUTTER INSTRUMENT GLASS CAPILLARIES

**FORMULATIONS:** Sutter currently offers two formulations of glass; borosilicate and aluminosilicate. Borosilicate glass has been and continues to be the material of choice for most routine work. It is used for microelectrodes, patch-type pipettes, microperfusion and collection pipettes, and microinjection needles. Aluminosilicate glass, because of its special properties, is usually reserved for the production of ultrafine tip recording microelectrodes, ion-selective micropipettes and certain patch type pipettes.

These two glasses differ in the following characteristics and behaviors: 1) Aluminosilicate melts at higher temperatures and is workable over a much narrower temperature range than borosilicate. 2) With the exception of the final tapers on very fine tipped micropipettes, the original ratio of the capillary's inner to outer diameter will remain unchanged over the total taper length for pipettes formed from borosilicate glass. However, aluminosilicate glass shows a marked tendency to thin out as it is drawn to a tip. This behavior has allowed us to form extremely fine tips (200 to 300 Angstroms) at moderately short tapers (5-6mm).\* 3) The resistivity of aluminosilicate glass is several orders of magnitude greater than borosilicate; thus, it will reduce leakage currents when used for ion-selective pipettes. 4) Aluminosilicate is somewhat 'harder' than borosilicate, thus it is less tolerant of shearing forces, but is stronger overall.

**SIZES:** Sutter offers borosilicate capillaries in a wide variety of sizes as well as several multibarrel configurations. Two wall thickness classes are recognized: standard wall - the ratio of inner to outer diameter is less than .75; and thin-wall - where the ratio is greater than .75. All other factors being equal, the thicker the wall of pulled tubing, the longer will be the taper and the finer the final tip. Thus, thin-walled capillaries are recommended for microinjection needles and low resistance (less than 50 Mohm) voltage clamp pipettes. Standard wall tubing is suitable for microelectrodes, patch-type pipettes, and those pipettes where additional wall thickness is necessary for mechanical reasons. The aluminosilicate capillaries are the thickest wall currently available and are a Sutter exclusive.

**FILAMENTS:** For situations where pipette filling is difficult, most capillary sizes are available with a glass filament.

**INFORMATION:** Please contact us at the address or phone number above if you have any questions about available glass or its recommended uses. Information on cleaning and storing glass capillaries is also available.

\*Our observations on glass behavior have been made using instruments manufactured by Sutter Instrument Company (pullers), and documented using our scanning electron microscope facilities. Sutter Instrument Company cannot guarantee that like results can be obtained with other equipment, particularly where aluminosilicate glass is concerned.

# SUTTER INSTRUMENT COMPANY

## GLASS PRICE LIST

PART NO.	DESCRIPTION (ODxID)		PRICE
<b>BOROSILICATE</b>			
B120-90-10	1.20mm X 0.90mm, 10cm,	250pcs.	\$ 15.00
B150-110-10	1.50mm X 1.10mm, 10cm,	250pcs.	30.00
B100-50-10	1.00mm X 0.50mm, 10cm,	225pcs.	15.00
B100-50-15	1.00mm X 0.50mm, 15cm,	225pcs.	25.00
B100-58-10	1.00mm X 0.58mm, 10cm,	500pcs.	20.00
B100-58-15	1.00mm X 0.58mm, 15cm,	500pcs.	30.00
BF100-50-10	1.00mm X 0.50mm, 10cm, Filament,	225pcs.	15.00
BF100-50-15	1.00mm X 0.50mm, 15cm, Filament,	225pcs.	15.00
BF100-58-10	1.00mm X 0.58mm, 10cm, Filament,	500pcs.	45.00
BF100-58-15	1.00mm X 0.58mm, 15cm, Filament,	500pcs.	75.00
BF100-78-10	1.00mm X 0.78mm, 10cm, Filament,	500pcs.	55.00
BF100-78-15	1.00mm X 0.78mm, 15cm, Filament,	250pcs.	40.00
B120-69-10	1.20mm X 0.69mm, 10cm,	500pcs.	30.00
B120-69-15	1.20mm X 0.69mm, 15cm,	500pcs.	45.00
BF120-60-10	1.20mm X 0.60mm, 10cm, Filament,	225pcs.	15.00
BF120-69-10	1.20mm X 0.69mm, 10cm, Filament,	250pcs.	35.00
BF120-69-15	1.20mm X 0.69mm, 15cm, Filament,	250pcs.	50.00
BF120-94-10	1.20mm X 0.94mm, 10cm, Filament,	500pcs.	75.00
BF120-94-15	1.20mm X 0.94mm, 15cm, Filament,	250pcs.	60.00
B150-86-10	1.50mm X 0.86mm, 10cm,	250pcs.	25.00
B150-86-15	1.50mm X 0.86mm, 15cm,	250pcs.	35.00
BF150-75-10	1.50mm X 0.75mm, 10cm, Filament,	225pcs.	30.00
BF150-86-10	1.50mm X 0.86mm, 10cm, Filament,	250pcs.	50.00
BF150-86-15	1.50mm X 0.86mm, 15cm, Filament,	250pcs.	75.00
BF150-117-10	1.50mm X 1.17mm, 10cm, Filament,	250pcs.	60.00
BF150-117-15	1.50mm X 1.17mm, 15cm, Filament,	100pcs.	35.00
B200-116-10	2.00mm X 1.16mm, 10cm,	250pcs.	35.00
B200-116-15	2.00mm X 1.16mm, 15cm,	250pcs.	55.00
BF200-100-10	2.00mm X 1.00mm, 10cm, Filament,	225pcs.	45.00
BF200-116-10	2.00mm X 1.16mm, 10cm, Filament,	250pcs.	80.00
BF200-116-15	2.00mm X 1.16mm, 15cm, Filament,	250pcs.	120.00
BF200-156-10	2.00mm X 1.56mm, 10cm, Filament,	250pcs.	100.00
BF200-156-15	2.00mm X 1.56mm, 15cm, Filament,	100pcs.	65.00
2BF100-50-10	2 Bbl. X 0.5mmD, 10cm, Filament,	75pcs.	18.00
2BF100-75-10	2 Bbl. X 0.75mmD, 10cm, Filament,	75pcs.	18.00
2BF150-10	2 Bbl. X 1.5mmD, 10cm, Filament,	100pcs.	55.00
2BF150-15	2 Bbl. X 1.5mmD, 15cm, Filament,	100pcs.	85.00
3BF100-50-10	3 Bbl. X 0.5mmD, 10cm, Filament,	75pcs.	22.00
3BF100-75-10	3 Bbl. X 0.75mmD, 10cm, Filament,	75pcs.	22.00
3BF120-10	3 Bbl. X 1.2mmD, 10cm, Filament,	100pcs.	65.00
3BF120-15	3 Bbl. X 1.2mmD, 15cm, Filament,	100pcs.	95.00
<b>ALUMINOSILICATE</b>			
AF100-58-10	1.00mm X 0.58mm, 10cm, Filament,	500pcs.	50.00
AF100-58-15	1.00mm X 0.58mm, 15cm, Filament,	500pcs.	75.00
A100-62-10	1.00mm X 0.62mm, 10cm,	250pcs.	60.00
AF100-68-10	1.00mm X 0.68mm, 10cm, Filament,	250pcs.	60.00
A120-75-10	1.20mm X 0.75mm, 10cm,	250pcs.	70.00
AF120-75-10	1.20mm X 0.75mm, 10cm, Filament,	250pcs.	70.00
A150-100-10	1.50mm X 1.0mm, 10cm,	250pcs.	75.00
AF150-96-10	1.50mm X 0.96mm, 10cm, Filament,	250pcs.	75.00

ORDER FROM: SUTTER INSTRUMENT COMPANY  
P.O. BOX 3592  
SAN RAFAEL, CA 94912

Phone: (415) 459-7327  
Telex: 6503036228  
Answer Back: 6503036228 MCIUW

Sutter Instrument Company reserves the right to change or modify prices and/or specifications at any time.



ADAIR L. OESTERLE  
TECHNICAL SUPPORT  
SUTTER INSTRUMENT COMPANY  
415.883.0128 (WK) 415.883.0572 (FAX)  
[adajr@sutter.com](mailto:adajr@sutter.com)

## Centering Your Filament after Filament Replacement

When replacing your filament, it is important that you center the filament relative to the gas jet, center the glass within the box or trough filament, and position the gas jet 2-3mm below the filament.

To center the glass within the filament, slide the brass jaws up or down for gross adjustments and use the eccentrics for fine adjustments (see diagram on next page). The eccentric screws are located on the "L" shaped panel behind the right puller bar. Loosen the locking screws to the right of each eccentric and adjust the eccentric to center the glass within the filament. Once the glass is centered, tighten the locking screws to maintain this position.

After pulling a pair of pipettes, remove them from the puller bars and hold them side by side to compare the taper length of each. If the taper of the pipettes vary in length, it indicates that the filament is not perfectly centered relative to the gas jet and one side is experiencing more cooling. To correct this, loosen the clamping screws and move the filament very slightly toward the shorter pipette. Then tighten the clamping screws and repeat this process. Several iterations before you get it centered properly.

If you need additional help, please

Scanned

**SUTTER INSTRUMENT COMPANY**  
51 DIGITAL DRIVE, NOVATO, CA 94949  
TEL: (415) 883-0128 FAX: (415) 883-0572 EMAIL: [INFO@SUTTER.COM](mailto:INFO@SUTTER.COM)



**SUTTER INSTRUMENT COMPANY  
TECHNICAL SUPPORT  
BURNING OUT FILAMENTS**

Filaments will most often burn out if you have failed to run a new ramp test after installing a new filament or after changing glass. If your filaments are burning out, please refer to the following checklist to help determine the source of the problem.

➤ **You just changed to a different kind of glass.**

If your new glass has a large outer diameter and/or a thick wall (e.g. 1.5mm OD x .86mm ID), it is possible that the filament installed in your pulper is unable to create enough heat to melt the glass. Please refer to your manual to determine the best filament types for your glass or call Sutter Instrument Company Technical Support for assistance.

➤ **You have just replaced your old trough filament with a new trough filament.**

Check the shape of the filament to see if it has the proper geometry. New trough filaments must be shaped according to the diagram below. For additional information please refer to the section titled "Heating Filaments" in your manual.

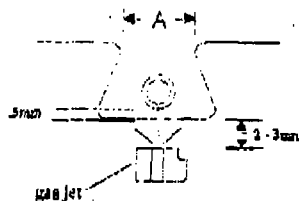

"A" represents about 2/3<sup>rd</sup> the length of the base, and the walls of the filament should create a 70-80 degree angle to the base.

➤ **You have just replaced a box filament with a trough filament.**

If the filament burns out *while pulling*, you need to replace the filament and run a new ramp test to find the appropriate heat setting (trough filaments require about half the amount of heat required by a box filament). In addition, please check the shape of your trough filament as shown above.

If the filament burns out *while running a ramp test*, it is possible that the trough filament is unable to create enough heat to melt the glass. This is most common if you have not shaped the filament (see diagram above) or are using glass with a large OD and/or a thick wall. Please refer to the manual or contact Sutter Instrument Company Technical Support to best determine the ideal filament for your glass.

➤ **You have just replaced a box filament with a new box filament.**

If the filament burns out *while pulling*, it is possible that the new box filament is smaller than the previous one and your present heat setting is too high. Replace the filament, then run a new ramp test to find the appropriate heat setting.

If the filament *burns out while running a ramp test*, check to see if the dimensions of the filament are the same as the one previously installed. If your new filament is smaller than the previous one, it is possible that the new filament can not create enough heat to melt the glass.

➤ **You have just installed a new program and/or increased the heat setting.**

The appropriate level of heat is determined by running a ramp test and it is recommended that you use a heat setting within +/- 20 units of the ramp test value. If you exceed the ramp test value by 50 to 100 units, you can easily burn out the filament.

**Please contact Technical Support for additional assistance.**

**SUTTER INSTRUMENT COMPANY**

51 DIGITAL DRIVE, NOVATO CA 94949

TEL: (415) 883-0128 FAX: (415) 883-0572 EMAIL: INFO@SUTTER.COM

Post-it® Fax Note 7671

Date	05.20.04	Pages	10
To	Lee	From	Gayle
Co./Dept.		Co.	Sutter Inst
Phone #	619 459 2600	Phone #	
Fax #	658-534	Fax #	



## IMPORTANT!

Before installing a new trough filament, it is necessary to "shape" the filament so that the walls angle inward at a 75 to 80 degree angle to the base. The opening at the top of the trough should be approximately 2.0mm. This shape of trough filament will produce the most efficient heating to your glass.

To shape your filament according to the diagram below, hold onto the base of the filament using flat needle-nosed pliers or needle holders and push in on each wing. See diagram below.

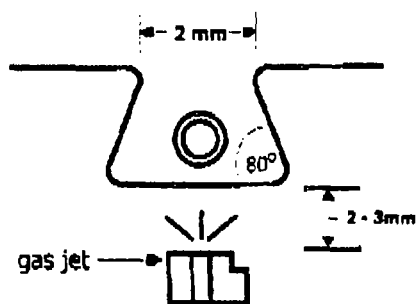

After installing your trough filament, you will need to run a new ramp test to establish the appropriate heat settings.



## Fire Polishing with the P-87 & P-97 Micropipette Pullers

The P-87 and P-97 micropipette pullers allow you to perform pseudo-fire polishing of pipette tips, but do not provide a way of visualizing the pipette during the heating process. Therefore, the duration and amount of heat required to attain the desired degree of polishing must be empirically established. For reproducible fire polishing it is important to be able to reposition the pipette each time in the same relative position to the filament. This T-shaped aluminum block allows for consistent repositioning of the pipette and has an adjustable set screw. A 1/16<sup>th</sup> hex key is required to adjust the length of the setting.

During fire polishing, the heat and time values are the only two parameters at play. The pull and velocity values are to be set at zero and the pressure value is to be disregarded since the air supply is not activated in this mode.

### Step by Step Instructions for Fire Polishing:

1. After pulling a pair of pipettes, keep them clamped in the puller bars.
2. Press <RESET> and choose a program to enter the fire polishing parameters.
3. According to the type of puller and filament you are using, enter one of the fire polishing programs provided below:

Puller	Filament	Heat	Pull	Velocity	Time
P-97	Box	Ramp-50	0	0	150 to 200
P-97	Trough	Ramp-30	0	0	150 to 200
P-87	Box	Ramp-75	0	0	150 to 200
P-87	Trough	Ramp-50	0	0	150 to 200

4. With the pipettes still installed, manually push the puller bar toward the filament and place the spacer in the puller bar slot. Observe the position of the pipette in relation to the filament and adjust the screw of the spacer block so the puller bar is in a location that positions the tip of the pipette at the edge of the filament.
5. Press pull and the filament will heat up and exert a polish onto the pipette tip. The intensity and duration of heat will determine the extent of polish. To decrease the polish, reduce the heat or time in five unit increments. To increase the polish, exert the program multiple times, or increase the heat or time in five unit increments.

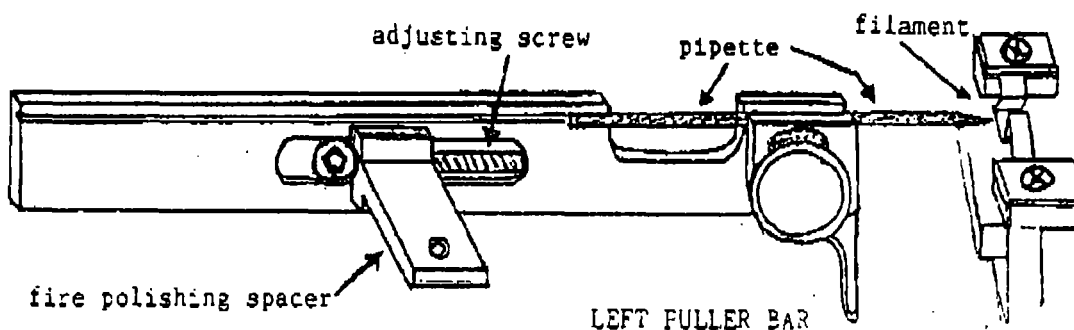

**SUTTER INSTRUMENT COMPANY**

40 LEVERONI COURT, NOVATO CA 94949

TEL: (415) 883-0128 FAX: (415) 883-0572 EMAIL: INFO@SUTTER.COM





**SUTTER INSTRUMENT COMPANY  
TECHNICAL SUPPORT**

## RAMP TEST

To choose an appropriate heat setting, you must first determine the amount of heat required to melt your glass by running a RAMP TEST. The heat value established by the ramp test will depend on the type of heating filament installed in your puller and the type of glass you are using. The ramp test value for a box filament will traditionally be 1.5 to 2 times the value for a trough filament.

A Ramp Test should be run when:

- Using the Puller for the First Time
- Whenever you Change the Filament
- Whenever you Change Glass
- Before Writing or Editing a Program

### How to Run a Ramp Test

- Enter any program number <0-99> for a P-97 or <0-9> for a P-87
- Press clear <CLR> to enter the control functions
- Press <0> to not clear all parameter values
- Press <1> to run a RAMP TEST
- Install glass and press <PULL>

*To interrupt the RAMP TEST or reset the display after a ramp test, press <RESET>*

When a ramp test is executed, the following events take place:

1. The puller increments the HEAT
2. As the HEAT output begins to soften the glass, the puller bars will move apart
3. The heat is then turned off when a certain factory-set Ramp Test velocity is reached
4. The Ramp Test value will be shown on the display

### Recommendations:

<i>PULLER</i>	<i>FILAMENT</i>	<i>HEAT VALUE</i>	<i>MAXIMUM HEAT</i>
P-97	Trough	Ramp + 15	Ramp + 25
P-97	BOX	Ramp + 5	Ramp + 30
P-87	Trough	Ramp	Ramp + 15
P-87	BOX	Ramp + 5	Ramp + 30

**CAUTION:** If your heat value is more than 30 to 50 units above the ramp test value (See table above), you will risk burning out or vaporizing the filament!

Please contact Sutter Instrument Company Technical Support for additional assistance.

### SUTTER INSTRUMENT COMPANY

51 DIGITAL DRIVE, NOVATO, CA 94949  
TEL: (415) 883-0128 FAX: (415) 883-0572 EMAIL: INFO@SUTTER.COM



## Using a P-97 manual with a P80-PC Puller

The P80-PC puller is no longer in production and the original P80-PC manuals have been universally banished to the upper shelves of most laboratories! Sutter currently produces two newer models of the puller, the P-87 and P-97 that have improved documentation. We can supply the P-97 manual to P80-PC users along with the following two-page addendum that documents the major differences. If you find other portions of the manual that do not apply, please contact Technical Support for further information.

### Cooling Air Delivery

The cooling air delivery system in the P80-PC consists of a Nitrogen Tank, a pressure gage and regulator, a micrometer-controlled orifice to adjust airflow, and finally a microprocessor controlled solenoid to determine air pulse delivery timing (TIME). In the P-97, there is an air compressor, reservoir tank and solenoid. Air pressure and solenoid timing are under microprocessor control.

The major functional difference in the two systems is how air delivery is controlled. In the P80-PC, one controls filament/glass cooling directly by controlling airflow with the airflow micrometer and air timing with the program parameter TIME.

There is a difference, and therefore possible confusion, in the use of the terms TIME and DELAY in the two pullers.

In the P80-PC, one uses the TIME mode to control the delay between the heating filament turning off/start of cooling air and when the hard pull is initiated. Because the cooling air pulse is initiated at the same time the heating filament turns off, the length of the delay, controlled by the TIME setting in the P80-PC, allows a degree of control over how much cooling has occurred (how viscous the glass is) before the hard pull is begun. On the P80-PC, the length of the air pulse is fixed at 300ms.

The P-97 air timing can be controlled in two different ways, DELAY or TIME. The first is identical to the method used in the P80-PC where the user controls the delay between the end of filament heat/cooling air start and the start of the hard pull. Unfortunately this parameter is called DELAY on the P-97, where it was previously referred to as the TIME on the P80-PC. In the alternative method of cooling in the P-97, one uses the TIME mode to control the duration of the air pulse. This type of TIME mode does not exist on the P80-PC and the P80-PC TIME works like a P-97 in Delay Mode.

In other words! The P-97 has two cooling methods, TIME (duration of air) and Delay (pause between heat OFF and pull ON, during which period the glass is being cooled). The P80-PC has one cooling method, the TIME mode. The TIME mode of the P80-PC equals the DELAY mode of the P-97.

### Ramp Test

The two pullers use different rates of current increase during the ramp test. P-97 ramp test increments current more slowly than the P80-PC ramp test. In effect this means that the values given by the ramp test for the same piece of glass and filament will be larger for the P80-PC than for the P-97. Thus, when using the ramp value for the starting reference for the HEAT value in a program, it should be less (with respect to the ramp value) for the P80-PC than for the P-97.



## Specifics Changes

The above differences translate into the following specific changes in the P-97 manual for P80-PC users:

1. Any references to changing air pressure on the P-97 should be interpreted as changes in airflow (Adjusting the airflow micrometer) on the P80-PC.
2. The P80-PC cooling mode TIME is identical to the Delay Mode on the P-97. Ignore references in the P97 manual to adjusting the parameter TIME and the "Time Mode" of cooling air delivery.
3. With regards to the ramp test value: Where the P-97 manual says to use the Ramp Value + 15 units for a trough filament, use the Ramp Value for the heat setting on the P80-PC. Where the P-97 manual says to use the Ramp Value for a box filament, use the Ramp Value - 5 units for the P80-PC.

The following differences also exist, but are of less consequence in pulling pipettes:

1. The P-97 manual refers to 8 "Software Control Functions". Only 2 of these, the Ramp Test and the Memory Test exist on the P80-PC. Ignore references to the remainder of the functions: "Change Air Pressure", "Air Mode", "Air Time at Start of Pull", "Air Time at End of Pull", "Reset Time and Date", "Write-Protect the Program". None of these functions exist on the P80-PC
2. The P80-PC does not have a "Humidity controlled chamber surrounding the heating filament" (see page 1). Thus any references to the chamber can be ignored.
3. The P80-PC does not record or display the "Time of the pull". If you wish to know how long the heating filament was on, it can be accurately timed with a hand held stopwatch.
4. The P80-PC is only capable of storing 10 programs, not the 100 stated for the P-97.
5. Write Protection of programs is not available on the P80-PC.
6. The P80-PC does not record or display the time/date of the last program edit.

## Specific P80-PC Concerns & Settings

1. Nitrogen Tank should have at least 700psi indicated on pressure gage. Once the tank pressure drops below 700psi, one can experience variability with cooling. Contact local welding shops and/or gas companies for refills or contact Sutter Instrument Company for replacement tanks. The pressurized tanks are considered biohazardous and the associated shipping rates exceed \$150. Therefore, it is much more economical to refill the tank. The tank is rated for up to 2,000psi.
2. The outgoing pressure regulator should be set at 50psi. You may have to run through a few pulling cycles to accurately adjust the outgoing pressure.
3. The airflow micrometer behind the left puller bar should be set somewhere between the 1 and 1.25.
4. The gas jet should be adjusted 2mm below the base of the filament.
5. The TIME mode (which is the same as DELAY mode on the P-97) should be set somewhere within the range of 80 and 150.



## Sutter Instrument Company Technical Tip Creating a Large Tip

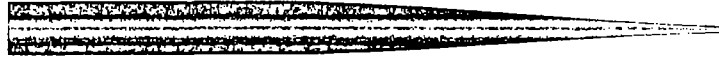

Total Taper (shoulder to tip) 6 to 7 mm and a 25 $\mu$  to 50 $\mu$  Tip

Puller = P-97 Glass = B100-50-10 Filament = FT330B, 3mm Trough

Pressure = 500

Line 1) Heat = Ramp Pull = 0 Vel = 160 Time = 150

Line 2) Heat = Ramp Pull = 90 Vel = 75 Time = 150

**Directions to modify program for your glass and filament:**

- ❖ Install the above program and adjust the velocity in Line 1 so the glass consistently separates on Line 2.
- ❖ If the puller bars drift apart and the glass separates on Line 1, reduce the velocity in Line 1 by five units until you get separation on Line 2.
- ❖ Once the tip is approximately 10 to 100 microns, adjust the velocity in Line 2 to modify the size of the final tip.

To reduce the tip size, reduce the velocity in Line 2 by five units at a time.

To increase the tip size, increase the velocity in Line 2 by five units at a time.

➤ *Example results when adjusting Line 2 Velocity settings:*

VELOCITY (UNITS)	TIP (OD) (MICRONS)
60	10
65	20
70	30-40
75	50
80	>100

**Or install the following program:**

Line 1) Heat = Ramp Pull = 40 Vel = 40 Time = 150

Line 2) Heat = Ramp-20 Pull = 40 Vel = 65 Time = 150

Line 2) Heat = Ramp-40 Pull = 125 Vel = 65 Time = 150

As the jaws heat up, the tip will get smaller (12 $\mu$  to 15 $\mu$ ). To adjust for this change, take a five minute break after pulling a set of ten pipettes or use compressed air to cool down the brass jaws. These programs will give you about an 80% yield. Good Luck! Adair

### Sutter Instrument Company

51 Digital Drive, novato ca 94949

tel: (415) 883-0128 fax: (415) 883-0572 email: info@sutter.com



**SUTTER INSTRUMENT COMPANY  
PULLER BARS & FILAMENT BLOCK ASSEMBLY**

**1) LOOSEN BRASS SCREWS TO SLIDE BRASS JAWS  
UP OR DOWN TO MAKE GROSS ADJUSTMENTS**

**2) USE ECCENTRICS TO MAKE FINE ADJUSTMENTS**

**ECCENTRIC SCREW FOR  
VERTICAL ALIGNMENT (UP AND DOWN)**

**LOCKING SCREW**

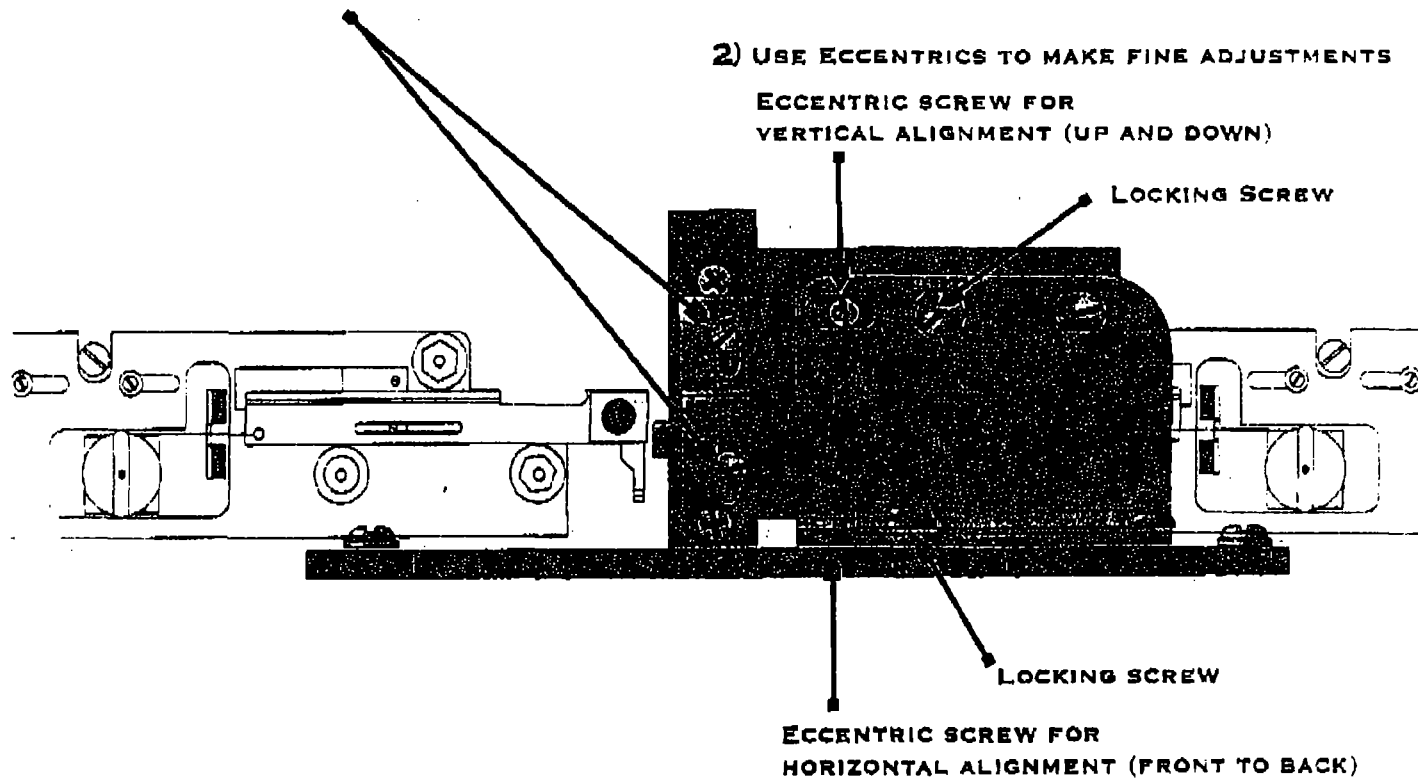

**LOCKING SCREW**

**ECCENTRIC SCREW FOR  
HORIZONTAL ALIGNMENT (FRONT TO BACK)**

**FOR ADDITIONAL ASSISTANCE PLEASE CONTACT TECHNICAL SUPPORT**

**PHONE: 415-883-0128 FAX: 415-883-0572 EMAIL: INFO@SUTTER.COM**



**SUTTER INSTRUMENT COMPANY**  
**PULLER BARS & FILAMENT BLOCK ASSEMBLY**

**1) LOOSEN BRASS SCREWS TO SLIDE BRASS JAWS  
UP OR DOWN TO MAKE GROSS ADJUSTMENTS**

**2) USE ECCENTRICS TO MAKE FINE ADJUSTMENTS**

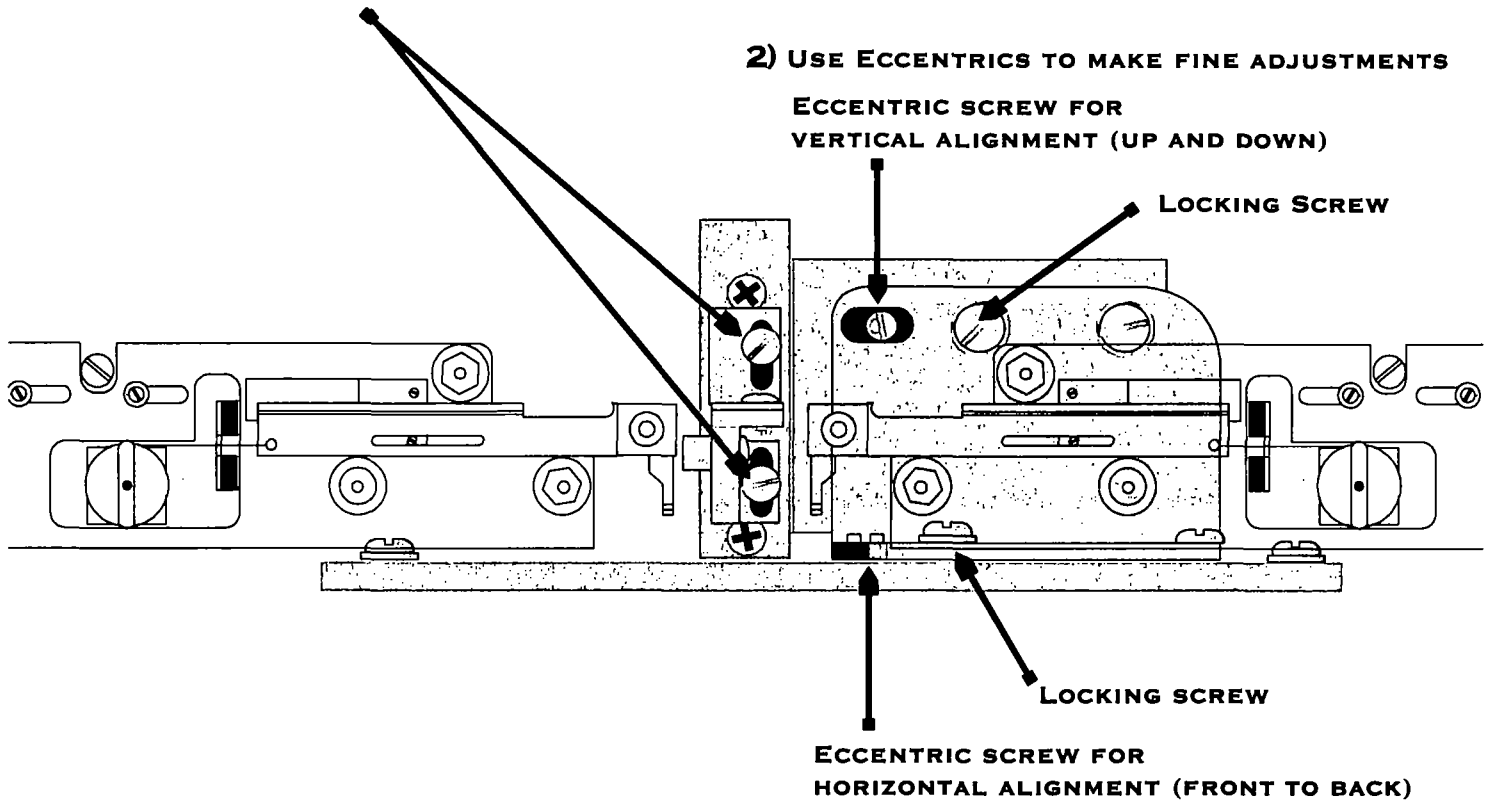

**FOR ADDITIONAL ASSISTANCE PLEASE CONTACT TECHNICAL SUPPORT**

**PHONE: 415-883-0128 FAX: 415-883-0572 EMAIL: INFO@SUTTER.COM**

## General Description

The Merlin Series of chillers is a compact portable line of refrigerated recirculators ranging in cooling capacity from 810 watts to 5045 watts. This new Series will replace the CFT Series of chillers. The Merlin chillers are the result of a 1½ year research and design effort by a dedicated cross functional team. This revolutionary new chiller utilizes NESLAB's 37 years of chiller design experience to offer:

## Features

- Up to 30% more cooling capacity
- Smaller footprint and overall size
- More standard features and options
  - Safety monitors for temperature, flow and fluid level
  - Additional pump choices
  - Tighter stability to  $\pm 0.1^{\circ}\text{C}$
  - Computer communications and control
- Improved reliability of pumps and motors
- Warranty doubled to 2 years

Available  
Spring 2000

## Applications

Lasers  
Condenser Cooling  
Diffusion Pumps  
Turbo-Molecular Pumps  
Vacuum Systems  
GC/MS  
Electron Microscopes  
ICP  
FTIR  
Plasma Etch Equipment  
Sputtering Systems  
AA Graphite Furnace  
Resistance Welders



## Specifications

	M-25	M-33	M-75	M-100	M-150
Temperature Range	+5° C to +35° C	+5° C to +35° C	+5° C to +35° C	+5° C to +35° C	+5° C to +35° C
Stability	$\pm 0.1^{\circ}\text{C}$	$\pm 0.1^{\circ}\text{C}$	$\pm 0.15^{\circ}\text{C}$	$\pm 0.1^{\circ}\text{C}$	$\pm 0.1^{\circ}\text{C}$
Cooling Capacity 60 Hz	810 watts @ 20° C 725 watts @ 20° C	1250 watts @ 20° C 1125 watts @ 20° C	2410 watts @ 20° C 2180 watts @ 20° C	3500 watts @ 20° C 3500 watts @ 20° C	5045 watts @ 20° C 4540 watts @ 20° C
Pumping Options	2.7 gpm @ 7.5 psi 1.6 gpm @ 60 psi	2.7 gpm @ 7.5 psi 1.6 gpm @ 60 psi 3.4 gpm @ 60 psi	1.6 gpm @ 60 psi 3.4 gpm @ 60 psi	3.4 gpm @ 60 psi 10 gpm @ 40 psi	3.4 gpm @ 60 psi 10 gpm @ 40 psi
Reservoir Volume	0.6 gallons/3 liters	0.6 gallons/3 liters	0.6 gallons/3 liters	0.8 gallons/3 liters	0.6 gallons/3 liters
Dimensions In. (HxWxD) Cm.	23 7/8 x 12 5/8 x 20 1/8 60.6 x 32.1 x 51.1	23 7/8 x 12 5/8 x 20 1/8 60.8 x 32.1 x 51.1	25 5/8 x 16 1/4 x 23 3/8 67.6 x 41.3 x 59.3	29 3/8 x 21 1/4 x 29 5/8 74.6 x 54 x 72.7	29 3/8 x 21 1/4 x 29 5/8 74.6 x 54 x 72.7
Electrical Requirements	115V/60Hz-100V/60Hz 230V/50Hz	115V/60Hz- 200V/50-60Hz 230V/50Hz	200-230V/60Hz-200V/50Hz 230V/50Hz	200-230V/60Hz-200V/50Hz 400V/50Hz/3 phase	200-230V/60Hz-200V/50Hz 400V/50Hz/3 phase

NESLAB Instruments • PO Box 1178 • Portsmouth, NH • 03802-1178  
800/4 NESLAB Fax: 603-436-8411 www.neslab.com

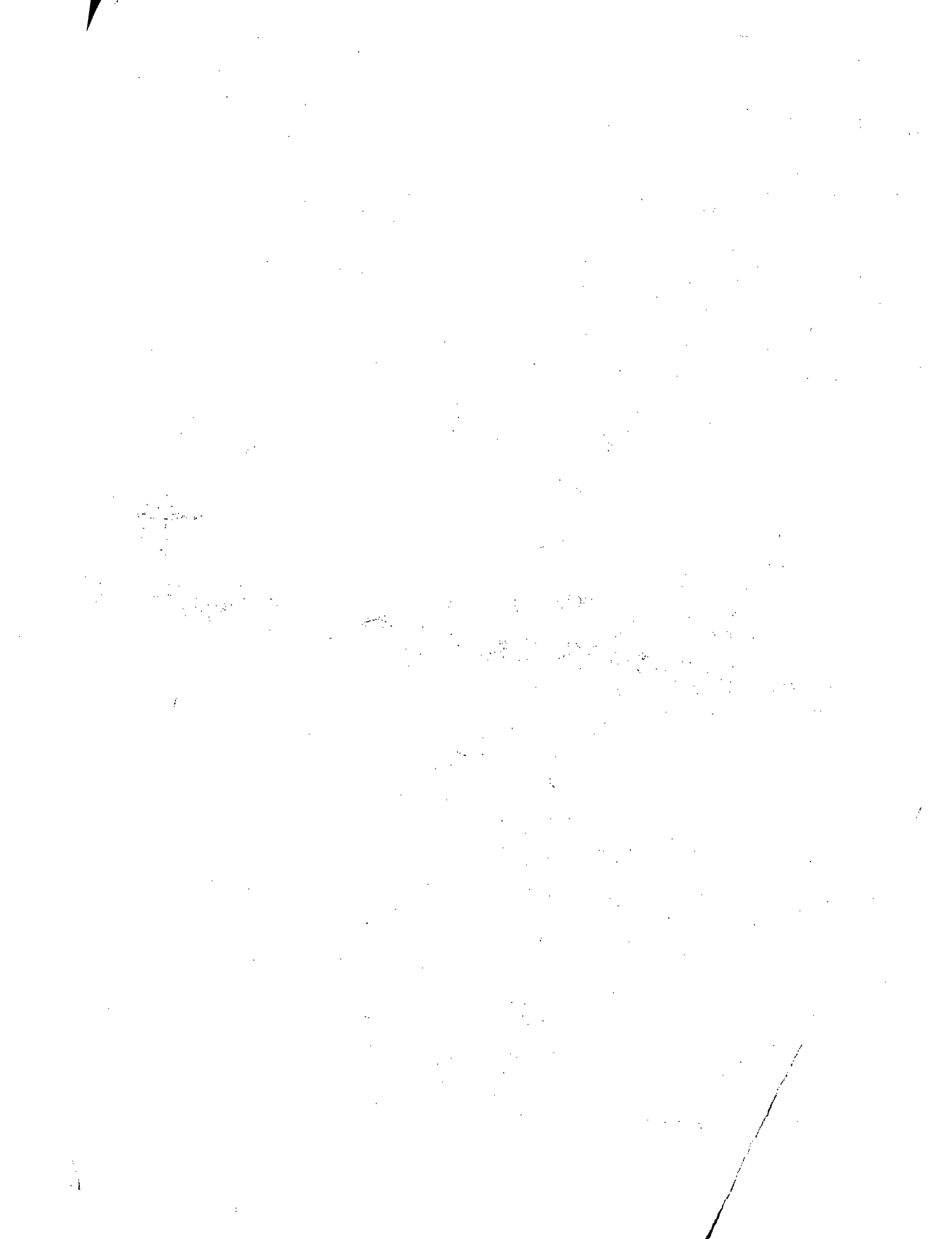



# Thermo NESLAB

P.O. Box 1178  
 Portsmouth, NH 03802-1178 U.S.A.  
 Telephone (800) 256-0830  
 Fax (603) 436-8411

## QUOTATION

www.thermoneslab.com

### Temperature Controlled Liquid Systems

Prepared For: Biophysics Lab  
 UCSD  
 Omar Clay

Quote No.: **915852**  
 Date: 6/22/01  
 Your Ref.: telecon  
 Sunny Vestal

Phone:  
 Fax: 858-534-7697

ITEM	QTY.	DESCRIPTION	UNIT PRICE	TOTAL
1	1	<p><b>Thermo NESLAB Merlin M-25 Refrigerated Recirculating Chiller</b></p> <ol style="list-style-type: none"> <li>1. Heat removal capacity: 810 watts (2762 BTU/HR) at +20°C recirculating temperature and +20°C ambient</li> <li>2. Standard Temperature range +5°C to +35°C</li> <li>3. Stability: ±0.1°C</li> <li>4. Ambient range: +10°C to +35°C</li> <li>5. Pump type: PD-1 (Positive displacement) Includes improved pump/motor coupling</li> <li>6. Pumping capacity (60 Hz): 1.6 gpm at 60 psi/6 lpm at 4 bar</li> <li>7. Built in user adjustable pressure reducer/flow controller located at rear of chiller.</li> <li>8. External circulation to both open and closed loop systems</li> <li>9. Viewable 0.5 gallon/1.8 liter polyethylene reservoir.</li> <li>10. Reservoir drain with ball valve for easy fluid changes</li> <li>11. Plumbing                         <ul style="list-style-type: none"> <li>• ½" FPT Inlet/Outlet Fittings</li> <li>• Includes two ½" and two 3/8" hose barb adapters</li> </ul> </li> <li>12. Compatible Fluids (Fluid Temperature Range)                         <ul style="list-style-type: none"> <li>• Distilled Water (+5°C to +85°C)</li> <li>• Deionized Water (1-3 Megohm-cm) (+5°C to +85°C)</li> <li>• 50/50 Uninhibited Propylene Glycol/Water (-15°C to +60°C)</li> <li>• 50/50 Uninhibited Ethylene Glycol/Water (-15°C to +60°C)</li> <li>• 50/50 Inhibited Propylene Glycol/Water (-15°C to +90°C)</li> <li>• 50/50 Inhibited Ethylene Glycol/Water (-15°C to +90°C)</li> </ul> </li> <li>13. Refrigeration System:                         <ul style="list-style-type: none"> <li>• 1/4 HP compressor designed for continuous operation</li> <li>• Hot gas bypass temperature control for increased compressor life</li> <li>• Air cooled refrigeration condenser</li> <li>• Refrigerant type: R-134A</li> <li>• Air Intake Requirements: 176 CFM</li> </ul> </li> <li>14. Front panel recirculating fluid pressure gauge</li> <li>15. Removable front grille for ease of routine maintenance</li> <li>16. Equipped with 4 castors, 2 locking</li> <li>17. Physical dimensions (HxWxD)</li> </ol>	\$2,170.00	\$2,170.00