

MIPSpro Assembly Language Programmer's Guide

Document Number 007-2418-004

Contributors: Originally written by Larry Huffman, David Graves; Edited by Larry Huffman, Cindy Kleinfeld; Production by Chris Glazek and David Clarke; Engineering contributions by Bean Anderson, Jim Dehnert, Suneel Jain, Michael Murphy.

St. Peter's Basilica image courtesy of ENEL SpA and InfoByte SpA. Disk Thrower image courtesy of Xavier Berenguer, Animatica.

Copyright © 1996, 1999 Silicon Graphics, Inc. All Rights Reserved. This document or parts thereof may not be reproduced in any form unless permitted by contract or by written permission of Silicon Graphics, Inc.

LIMITED AND RESTRICTED RIGHTS LEGEND

Use, duplication, or disclosure by the Government is subject to restrictions as set forth in the Rights in Data clause at FAR 52.227-14 and/or in similar or successor clauses in the FAR, or in the DOD, DOE or NASA FAR Supplements. Unpublished rights reserved under the Copyright Laws of the United States. Contractor/manufacturer is Silicon Graphics, Inc., 1600 Amphitheatre Pkwy., Mountain View, CA 94043-1351.

Autotasking, CF77, CRAY, Cray Ada, CraySoft, CRAY Y-MP, CRAY-1, CRInform, CRI/*TurboKiva*, HSX, LibSci, MPP Apprentice, SSD, SUPERCLUSTER, UNICOS, X-MP EA, and UNICOS/mk are federally registered trademarks and Because no workstation is an island, CCI, CCMT, CF90, CFT, CFT2, CFT77, ConCurrent Maintenance Tools, COS, Cray Animation Theater, CRAY APP, CRAY C90, CRAY C90D, Cray C++ Compiling System, CrayDoc, CRAY EL, CRAY J90, CRAY J90se, CrayLink, Cray NQS, Cray/REELibrarian, CRAY S-MP, CRAY SSD-T90, CRAY SV1, CRAY T90, CRAY T3D, CRAY T3E, CrayTutor, CRAY X-MP, CRAY XMS, CRAY-2, CSIM, CVT, Delivering the power . . ., DGauss, Docview, EMDS, GigaRing, HEXAR, IOS, ND Series Network Disk Array, Network Queuing Environment, Network Queuing Tools, OLNEL, RQS, SEGLDR, SMARTE, SUPERLINK, System Maintenance and Remote Testing Environment, Trusted UNICOS, and UNICOS MAX are trademarks of Cray Research, Inc., a wholly owned subsidiary of Silicon Graphics, Inc.

DynaText and DynaWeb are registered trademarks of Inso Corporation. Silicon Graphics and the Silicon Graphics logo are registered trademarks of Silicon Graphics, Inc. UNIX is a registered trademark in the United States and other countries, licensed exclusively through X/Open Company Limited. X/Open is a trademark of X/Open Company Ltd. The X device is a trademark of the Open Group.

The UNICOS operating system is derived from UNIX® System V. The UNICOS operating system is also based in part on the Fourth Berkeley Software Distribution (BSD) under license from The Regents of the University of California.

Record of Revision

<i>Version</i>	<i>Description</i>
	1996. Original Printing.
7.3	March, 1999 Revised to support the MIPSpro 7.3 release.

Contents

	<i>Page</i>
About This Guide	ix
Related Publications	ix
Obtaining Publications	x
Conventions	x
Reader Comments	xi
Registers [1]	1
Register Format	1
General Registers	1
Special Registers	3
Floating-Point Registers	4
Floating-Point Condition Codes	6
Addressing [2]	7
Instructions to Load and Store Unaligned Data	7
Address Formats	8
Address Descriptions	9
Exceptions [3]	11
Main Processor Exceptions	11
Floating-Point Exceptions	11
Lexical Conventions [4]	13
Tokens	13
Comments	14
Identifiers	14
007-2418-004	iii

	<i>Page</i>
Constants	14
Scalar Constants	14
Floating-Point Constants	15
String Constants	16
Multiple Lines Per Physical Line	17
Section and Location Counters	17
Statements	19
Label Definitions	19
Null Statements	19
Keyword Statements	20
Expressions	20
Precedence	20
Expression Operators	21
Data Types	21
Type Propagation in Expressions	23
Relocations	24
The Instruction Set [5]	25
Instruction Classes	25
Reorganization Constraints and Rules	25
Instruction Notation	25
Instruction Set	27
Load and Store Instructions	27
Load Instruction Descriptions	28
Store Instruction Descriptions	32
Computational Instructions	35
Computational Instructions	35
Computational Instruction Descriptions	38
Jump and Branch Instructions	47
Jump and Branch Instructions	47

	<i>Page</i>
Jump and Branch Instruction Descriptions	49
Special Instructions	52
Special Instruction Descriptions	52
Coprocessor Interface Instructions	52
Coprocessor Interface Summary	53
Coprocessor Interface Instruction Descriptions	54
Coprocessor Instruction Set [6]	57
Instruction Notation	57
Floating-Point Instructions	58
Floating-Point Formats	58
Floating-Point Load and Store Formats	59
Floating-Point Load and Store Descriptions	60
Floating-Point Computational Formats	60
Floating-Point Computational Instruction Descriptions	64
Floating-Point Relational Operations	65
Floating-Point Relational Instruction Formats	67
Floating-Point Relational Instruction Descriptions	69
Floating-Point Move Formats	71
Floating-Point Move Instruction Descriptions	72
System Control Coprocessor Instructions	73
System Control Coprocessor Instruction Formats	73
System Control Coprocessor Instruction Descriptions	73
Control and Status Register	74
Exception Trap Processing	76
Invalid Operation Exception	77
Division-by-zero Exception	77
Overflow Exception	78

	<i>Page</i>
Underflow Exception	78
Inexact Exception	79
Unimplemented Operation Exception	79
Floating-Point Rounding	79
Linkage Conventions [7]	81
Introduction	81
Program Design	82
The Stack Frame	82
The Shape of Data	90
Examples	90
Example 1: Non-leaf procedure	90
Example 2: Leaf Procedure	92
Writing Assembly Language Code	94
Pseudo Op-Codes (Directives) [8]	95
Op-Codes	95
PIC Assembly Code	106
Example 3: KPIC directives example	107
Index	111
Figures	
Figure 1. Section and Location Counters	18
Figure 2. Floating Point Formats	58
Figure 3. Floating Control and Status Register 31	75
Figure 4. Stack Organization for -32	84
Figure 5. Stack Organization for -n32 and -64	85

	<i>Page</i>
Figure 6. Stack Example	87
Tables	
Table 1. General (Integer) Registers (-32)	2
Table 2. General (Integer) Registers (64-Bit)	3
Table 3. Special Registers	4
Table 4. Floating-Point Registers (-32)	4
Table 5. Floating-Point Registers (-64)	5
Table 6. Floating-Point Registers (-n32)	6
Table 7. Address Formats	8
Table 8. Assembler Addresses	9
Table 9. Backslash Conventions	16
Table 10. Expression Operators	21
Table 11. Data Types	22
Table 12. Load and Store Format Summary	27
Table 13. Load Instruction Descriptions	29
Table 14. Load Instruction Descriptions for MIPS3/4 Architecture Only	31
Table 15. Store Instruction Descriptions	33
Table 16. Store Instruction Descriptions for MIPS3/4 Architecture Only	34
Table 17. Computational Format Summaries	35
Table 18. Computational Instruction Descriptions	38
Table 19. Computational Instruction Descriptions for MIPS3/4 Architecture	44
Table 20. Jump and Branch Format Summary	48
Table 21. Jump and Branch Instruction Descriptions	49
Table 22. Special Instruction Descriptions	52
Table 23. Coprocessor Interface Formats	53
Table 24. Coprocessor Interface Instruction Descriptions	54
Table 25. Floating-Point Load and Store Formats	59
Table 26. Floating-Point Load and Store Descriptions	60

	<i>Page</i>
Table 27. Floating-Point Computational Instructions	61
Table 28. Floating-Point Computational Instruction Descriptions	64
Table 29. Floating-Point Relational Operators	66
Table 30. Floating-Point Relational Instruction Formats	68
Table 31. Floating-Point Relational Instruction Descriptions	70
Table 32. Floating-Point Move Instruction Descriptions	72
Table 33. System Control Coprocessor Instruction Descriptions	74
Table 34. Parameter Passing (-32)	88
Table 35. Parameter Passing (-n32 and -64)	88
Table 36. Pseudo Op-Codes	95

About This Guide

This publication describes the assembly language supported by the IRIX operating system, its syntax rules, and how to write assembly programs. For information about assembling and linking an assembly language program, see the *MIPSpro Compiling and Performance Tuning Guide*.

This book assumes that you are an experienced assembly language programmer. The assembler produces object modules from the assembly instructions that the C and Fortran compilers generate. It therefore lacks many of the functions normally present in an assembler. You should use the assembler only when you must:

- Maximize the efficiency of a routine, which might not be possible in C, Fortran, or another high-level language (for example, to write low-level I/O drivers).
- Access machine functions unavailable in high-level languages or satisfy special constraints such as restricted register usage.
- Change the operating system.
- Change the compiler system.

The assembler converts assembly language statements into machine code. In most assembly languages, each instruction corresponds to a single machine instruction; however, some assembly language instructions can generate several machine instructions. This feature results in assembly programs that can run without modification on future machines, which might have different machine instructions.

In this release, the assembler supports compilations in `-o32`, `-n32`, and `-64` mode. Some of the implications of these different data sizes are explained in this book. For more information, see the *MIPSpro 64-Bit Porting and Transition Guide*.

Many assembly language instructions have direct equivalents to machine instructions. For more information about the operations of a specific architecture, see the book that is appropriate for your hardware type.

Related Publications

The following documents contain additional information that may be helpful:

- *MIPSpro 64-Bit Porting and Transition Guide*

- *MIPSpro Compiling and Performance Tuning Guide*
- *MIPSpro N32 ABI Handbook*

Obtaining Publications

Silicon Graphics maintains information about available publications at the following URL:

<http://techpubs.sgi.com/library>

This Web site contains information that allows you to browse documents online, order documents, and send feedback to Silicon Graphics. You can also order a printed Silicon Graphics document by calling 1 800 627 9307. Silicon Graphics employees may send electronic mail to orderdsk@cray.com.

Customers outside of the United States and Canada should contact their local service organization for ordering and documentation information.

Conventions

The following conventions are used throughout this document:

<u>Convention</u>	<u>Meaning</u>
<code>command</code>	This fixed-space font denotes literal items such as commands, files, routines, path names, signals, messages, and programming language structures.
<i>variable</i>	Italic typeface denotes variable entries and words or concepts being defined.
user input	This bold, fixed-space font denotes literal items that the user enters in interactive sessions. Output is shown in nonbold, fixed-space font.
[]	Brackets enclose optional portions of a command or directive line.

... Ellipses indicate that a preceding element can be repeated.

Reader Comments

If you have comments about the technical accuracy, content, or organization of this document, please tell us. Be sure to include the title and part number of the document with your comments.

You can contact us in any of the following ways:

- Send electronic mail to the following address:

`techpubs@sgi.com`

- Send a facsimile to the attention of "Technical Publications" at fax number +1 650 932 0801.
- Use the Suggestion Box form on the Technical Publications Library World Wide Web page:

`http://techpubs.sgi.com/library/`

- Call the Technical Publications Group, through the Technical Assistance Center, using one of the following numbers:

For Silicon Graphics IRIX based operating systems: 1 800 800 4SGI

For UNICOS or UNICOS/mk based operating systems or CRAY Origin2000 systems: 1 800 950 2729 (toll free from the United States and Canada) or +1 651 683 5600

- Send mail to the following address:

Technical Publications
Silicon Graphics, Inc.
1600 Amphitheatre Parkway
Mountain View, California 94043-1351

We value your comments and will respond to them promptly.

Registers [1]

This chapter describes the organization of data in memory, and the naming and usage conventions that the assembler applies to the CPU and FPU registers. See Chapter 7, page 81, for information regarding register use and linkage.

1.1 Register Format

The CPU uses four data formats: a 64-bit doubleword, a 32-bit word, a 16-bit halfword and an 8-bit byte. Byte ordering within each of the larger data formats – doubleword, word or halfword – the CPU's byte ordering scheme (or endian issues), affects memory organization and defines the relationship between address and byte position of data in memory.

For R4000 and earlier systems, byte ordering is configurable into either big-endian or little-endian byte ordering (configuration occurs during hardware reset). When configured as a big-endian system, byte 0 is always the most-significant (leftmost) byte. When configured as a little-endian system, byte 0 is always the least-significant (rightmost byte).

The R8000 CPU, at present, supports big-endian only.

1.2 General Registers

For the MIPS1 and MIPS2 architectures, the CPU has thirty-two 32-bit registers. In the MIPS3 architecture and above, the size of each of the thirty-two integer registers is 64-bit.

Table 1, page 2, and Table 2, page 3, summarize the assembler's usage, conventions and restrictions for these registers. The assembler reserves all register names; you must use lowercase for the names. All register names start with a dollar sign (\$).

The general registers have the names \$0..\$31. By including the file `regdef.h` (use `#include <regdef.h>`) in your program, you can use software names for some general registers.

The operating system and the assembler use the general registers \$1, \$26, \$27, \$28, and \$29 for specific purposes. Attempts to use these general registers in other ways can produce unexpected results.

Table 1. General (Integer) Registers (-32)

Register Name	Software Name (from <code>regdef.h</code>)	Use and Linkage
\$0		Always has the value 0.
\$1 or \$at		Reserved for the assembler.
\$2..\$3	v0-v1	Used for expression evaluations and to hold the integer type function results. Also used to pass the static link when calling nested procedures.
\$4..\$7	a0-a3	Pass the first 4 words of actual integer type arguments; their values are not preserved across procedure calls.
\$8..\$11 \$11..\$15	t0-t7 t4-t7 or ta0-ta3	Temporary registers used for expression evaluations; their values aren't preserved across procedure calls.
\$16..\$23	s0-s7	Saved registers. Their values must be preserved across procedure calls.
\$25	t9 or jp	PIC jump register.
\$26..\$27 or \$kt0..\$kt1	k0-k1	Reserved for the operating system kernel.
\$28 or \$gp	gp	Contains the global pointer.
\$29 or \$sp	sp	Contains the stack pointer.
\$30 or \$fp	fp or s8	Contains the frame pointer (if needed); otherwise a saved register (like s0-s7).
\$31	ra	Contains the return address and is used for expression evaluation.

Note: General register \$0 always contains the value 0. All other general registers are equivalent, except that general register \$31 also serves as the implicit link register for jump and link instructions. See Chapter 7, page 81, for a description of register assignments.

Table 2. General (Integer) Registers (64-Bit)

Register Name	Software Name (from <code>regdef.h</code>)	Use and Linkage
\$0		Always has the value 0.
\$1 or \$at		Reserved for the assembler.
\$2..\$3	v0-v1	Used for expression evaluations and to hold the integer type function results. Also used to pass the static link when calling nested procedures.
\$4..\$7 \$8..\$11	a0-a3 a4-a7 or ta0-ta3	Pass up to 8 words of actual integer type arguments; their values are not preserved across procedure calls.
\$12..\$15	t0-t3	Temporary registers used for expression evaluations; their values aren't preserved across procedure calls.
\$16..\$23	s0-s7	Saved registers. Their values must be preserved across procedure calls.
\$24..\$25	t8-t9	Temporary registers used for expression evaluations; their values aren't preserved across procedure calls.
\$26..\$27 or \$kt0..\$kt1	k0-k1	Reserved for the operating system kernel.
\$28 or \$gp	gp	Contains the global pointer.
\$29 or \$sp	sp	Contains the stack pointer.
\$30 or \$fp	fp or s8	Contains the frame pointer (if needed); otherwise a saved register (such as s0-s7).
\$31	ra	Contains the return address and is used for expression evaluation.

1.3 Special Registers

The CPU defines three special registers: PC (program counter), HI and LO, as shown in Table 3, page 4. The HI and LO special registers hold the results of the multiplication (`mult` and `multu`) and division (`div` and `divu`) instructions.

You usually do not need to refer explicitly to these special registers; instructions that use the special registers refer to them automatically.

Table 3. Special Registers

Name	Description
PC	Program Counter
HI	Multiply/Divide special register holds the most-significant 32 bits of multiply, remainder of divide
LO	Multiply/Divide special register holds the least-significant 32 bits of multiply, quotient of divide

Note: In MIPS3 architecture and later, the HI and Lo registers hold 64-bits.

1.4 Floating-Point Registers

The FPU has sixteen floating-point registers. Each register can hold either a single-precision (32-bit) or double-precision (64-bit) value. In case of a double-precision value, \$f0 holds the least-significant half, and \$f1 holds the most-significant half. For 32-bit systems, all references to these registers use an even register number (for example, \$f4). 64-bit systems can reference all 32 registers directly. The following tables summarize the assembler's usage conventions and restrictions for these registers.

Table 4. Floating-Point Registers (-32)

Register Name	Software Name (from fgregdef.h)	Use and Linkage
\$f0..\$f2	fv0-fv1	Hold results of floating-point type function (\$f0) and complex type function (\$f0 has the real part, \$f2 has the imaginary part).
\$f4..\$f10	ft0-ft3	Temporary registers, used for expression evaluation whose values are not preserved across procedure calls.

Register Name	Software Name (from <code>fgregdef.h</code>)	Use and Linkage
\$f12..\$f14	fa0-fa1	Pass the first two single- or double-precision actual arguments; their values are not preserved across procedure calls.
\$f16..\$f18	ft4-ft5	Temporary registers, used for expression evaluation, whose values are not preserved across procedure calls.
\$f20..\$f30	fs0-fs5	Saved registers, whose values must be preserved across procedure calls.

Table 5. Floating-Point Registers (-64)

Register Name	Software Name (from <code>fgregdef.h</code>)	Use and Linkage
\$f0, \$f2	fv0, fv1	Hold results of floating-point type function (\$f0) and complex type function (\$f0 has the real part, \$f2 has the imaginary part).
\$f1, \$f3, \$f4..\$f11	ft12, ft13, ft0-ft7	Temporary registers, used for expression evaluation; their values are not preserved across procedure calls.
\$f12..\$f19	fa0-fa7	Pass single- or double-precision actual arguments, whose values are not preserved across procedure calls.
\$f20..\$f23	ft8-ft11	Temporary registers, used for expression evaluation; their values are not preserved across procedure calls.
\$f24..\$f31	fs0-fs7	Saved registers, whose values must be preserved across procedure calls.

Table 6. Floating-Point Registers (-n32)

Register Name	Software Name(from fgregdef.h)	Use and Linkage
\$f0, \$f2	fv0, fv1	Hold results of floating-point type function (\$f0) and complex type function (\$f0 has the real part, \$f2 has the imaginary part.)
\$f1, \$f3 \$f4..\$f11	ft14, ft15, ft0-ft7	Temporary registers, used for expression evaluation; their values are not preserved across procedure calls.
\$f12..\$f19	fa0-fa7	Pass single- or double-precision actual arguments, whose values are not preserved across procedure calls.
\$f21, \$f23, \$f25, \$f27, \$f29, \$f31	ft8-ft13	Temporary registers, used for expression evaluation; their values are not preserved across procedure calls.
\$f20, \$f22, \$f24, \$f26, \$f28, \$f30	fs0-fs5	Saved registers, whose values must be preserved across procedure calls.

1.5 Floating-Point Condition Codes

The floating-point condition code registers hold the result of a floating-point comparison, and then decide whether or not to branch. For -32 compilers, there is only register: \$fcc0. For -n32 and -64 compilers, there are eight registers available: \$fcc0 through \$fcc7.

This chapter describes the formats that you can use to specify addresses. SGI CPUs use a byte addressing scheme. Access to halfwords requires alignment on even byte boundaries, and access to words requires alignment on byte boundaries that are divisible by four. Access to doublewords (for 64-bit systems) requires alignment on byte boundaries that are divisible by eight. Any attempt to address a data item that does not have the proper alignment causes an alignment exception.

2.1 Instructions to Load and Store Unaligned Data

The unaligned assembler load and store instructions may generate multiple machine language instructions. They do not raise alignment exceptions.

These instructions load and store unaligned data:

- Load doubleword left (LDL)
- Load word left (LWL)
- Load doubleword right (LDR)
- Load word right (LWR)
- Store doubleword left (SDL)
- Store word left (SWL)
- Store doubleword right (SDR)
- Store word right (SWR)
- Unaligned load doubleword (ULD)
- Unaligned load word (ULW)
- Unaligned load halfword (ULH)
- Unaligned load halfword unsigned (ULHU)
- Unaligned store doubleword (USD)
- Unaligned store word (USW)
- Unaligned store halfword (USH)

The following instructions load and store aligned data:

- Load doubleword (LD)
- Load word (LW)
- Load halfword (LH)
- Load halfword unsigned (LHU)
- Load byte (LB)
- Load byte unsigned (LBU)
- Store doubleword (SD)
- Store word (SW)
- Store halfword (SH)
- Store byte (SB)

2.2 Address Formats

The assembler accepts the following formats for addresses: Table 8 explains these formats in more detail.

Table 7. Address Formats

Format	Address
<i>(base-register)</i>	Base address (zero offset assumed)
<i>expression</i>	Absolute address
<i>expression (base-register)</i>	Based address
<i>index-register (base-register)</i>	Based address
<i>relocatable-symbol</i>	Relocatable address
<i>relocatable-symbol ± expression</i>	Relocatable address
<i>relocatable-symbol ± expression (index register)</i>	Indexed relocatable address

2.3 Address Descriptions

The assembler accepts any combination of the constants and operations described in this chapter for expressions in address descriptions.

Table 8. Assembler Addresses

Expression	Address Description
<i>(base-register)</i>	Specifies an indexed address, which assumes a zero offset. The <i>base-register</i> contents specify the address.
<i>expression</i>	Specifies an absolute address. The assembler generates the most locally efficient code for referencing a value at the specified address.
<i>expression (base-register)</i>	Specifies a based address. To get the address, the CPU adds the value of the expression to the contents of the base-register.
<i>index-register (base-register)</i>	Same as <i>expression(base-register)</i> , except that the index register is used as the offset.
<i>relocatable-symbol</i>	Specifies a relocatable address. The assembler generates the necessary instruction(s) to address the item and generates relocatable information for the link editor.
<i>relocatable-symbol ± expression</i>	Specifies a relocatable address. To get the address, the assembler adds or subtracts the value of the expression, which has an absolute value, from the relocatable symbol. The assembler generates the necessary instruction(s) to address the item and generates relocatable information for the link editor. If the symbol name does not appear as a label anywhere in the assembly, the assembler assumes that the symbol is external.

Expression	Address Description
<i>relocatable-symbol (index register)</i>	Specifies an indexed relocatable address. To get the address, the CPU adds the index register to the relocatable symbol's address. The assembler generates the necessary instruction(s) to address the item and generates relocatable information for the link editor. If the symbol name does not appear as a label anywhere in the assembly, the assembler assumes that the symbol is external.
<i>relocatable ± expression</i>	Specifies an indexed relocatable address. To get the address, the assembler adds or subtracts the relocatable symbol, the expression, and the contents of the index register. The assembler generates the necessary instruction(s) to address the item and generates relocation information for the link editor. If the symbol does not appear as a label anywhere in the assembly, the assembler assumes that the symbol is external.

This chapter describes the exceptions that you can encounter while running assembly programs. The system detects some exceptions directly, and the assembler inserts specific tests that signal other exceptions. This chapter lists only those exceptions that occur frequently.

3.1 Main Processor Exceptions

The following exceptions are the most common to the main processor:

- Address error exceptions, which occur when a data item is referenced that is not on its proper memory alignment or when an address is invalid for the executing process.
- Overflow exceptions, which occur when arithmetic operations compute signed values and the destination lacks the precision to store the result.
- Bus exceptions, which occur when an address is invalid for the executing process.
- Divide-by-zero exceptions, which occur when a divisor is zero.

3.2 Floating-Point Exceptions

The following are the most common floating-point exceptions:

- Invalid operation exceptions which include:
 - Magnitude subtraction of infinities, for example: -1 .
 - Multiplication of 0 by 1 with any signs.
 - Division of $0/0$ or $1/1$ with any signs.
 - Conversion of a binary floating-point number to an integer format when an overflow or the operand value for the infinity or NaN precludes a faithful representation in the format (see Chapter 4, page 13).
 - Comparison of predicates that have unordered operands, and that involve Greater Than or Less Than without Unordered.
 - Any operation on a signaling NaN.

- Divide-by-zero exceptions.
- Overflow exceptions occur when a rounded floating-point result exceeds the destination format's largest finite number.
- Underflow exceptions these occur when a result has lost accuracy and also when a nonzero result is between $2^{E_{\min}}$ (2 to the minimum expressible exponent).
- Inexact exceptions.

Lexical Conventions [4]

This chapter discusses lexical conventions for these topics:

- Tokens, Section 4.1, page 13
- Comments, Section 4.2, page 14
- Identifiers, Section 4.3, page 14
- Constants, Section 4.4, page 14
- Multiple lines per physical line, Section 4.5, page 17
- Sections and location counters, Section 4.6, page 17
- Statements, Section 4.7, page 19
- Expressions, Section 4.8, page 20

This chapter uses the following notation to describe syntax:

- | (vertical bar) means “or”
- [](square brackets) enclose options
- ± indicates both addition and subtraction operations

4.1 Tokens

The assembler has these tokens:

- Identifiers
- Constants
- Operators

The assembler lets you put blank characters and tab characters anywhere between tokens; however, it does not allow these characters within tokens (except for character constants). A blank or tab must separate adjacent identifiers or constants that are not otherwise separated.

4.2 Comments

The pound sign character (#) introduces a comment. Comments that start with a # extend through the end of the line on which they appear. You can also use C-language notation `/*...*/` to delimit comments.

The assembler uses `cpp` (the C language preprocessor) to preprocess assembler code. Because `cpp` interprets a # symbol in the first column as pragmas (compiler directives), do not start a # comment in the first column.

4.3 Identifiers

An identifier consists of a case-sensitive sequence of alphanumeric characters, including these:

- . (period)
- _ (underscore)
- \$ (dollar sign)

The first character of an identifier cannot be numeric.

If an identifier is not defined to the assembler (only referenced), the assembler assumes that the identifier is an external symbol. The assembler treats the identifier like a `.global` pseudo-operation (see Chapter 8, page 95). If the identifier is defined to the assembler and the identifier has not been specified as global, the assembler assumes that the identifier is a local symbol.

4.4 Constants

The assembler has these constants:

- Scalar constants
- Floating-point constants
- String constants

4.4.1 Scalar Constants

The assembler interprets all scalar constants as twos-complement numbers. In 32-bit mode, a scalar constant is 32 bits. 64 bits is the size of a scalar constant in 64-bit mode. Scalar constants can be any of the alphanumeric characters

0123456789abcdefABCDEF. You can use an `all` or `LL` suffix to identify a 64-bit constant.

Scalar constants can be one of the following:

- Decimal constants, which consist of a sequence of decimal digits without a leading zero.
- Hexadecimal constants, which consist of the characters `0x` (or `0X`) followed by a sequence of digits.
- Octal constants, which consist of a leading zero followed by a sequence of digits in the range `0..7`.

4.4.2 Floating-Point Constants

Floating-point constants can appear only in `.float` and `.double` pseudo-operations (directives) (see Chapter 8, page 95), and in the floating-point Load Immediate instructions (see Chapter 6, page 57). Floating-point constants have this format:

<code>+d1[.d2] [e E+d3]</code>

where:

- `d1` is written as a decimal integer and denotes the integral part of the floating-point value.
- `d2` is written as a decimal integer and denotes the fractional part of the floating-point value.
- `d3` is written as a decimal integer and denotes a power of 10.
- The “+” symbol is optional.

For example:

`21.73E-3`

represents the number `.02173`.

Optionally, `.float` and `.double` directives may use hexadecimal floating-point constants instead of decimal ones. A hexadecimal floating-point constant consists of:

`<+ or -> 0x <1 or 0 or nothing> . <hex digits> H 0x <hex digits>`

The assembler places the first set of hex digits (excluding the 0 or 1 preceding the decimal point) in the mantissa field of the floating-point format without attempting to normalize it. It stores the second set of hex digits into the exponent field without biasing them. It checks that the exponent is appropriate if the mantissa appears to be denormalizing. Hexadecimal floating-point constants are useful for generating IEEE special symbols, and for writing hardware diagnostics.

For example, either of the following generates a single-precision "1.0":

```
.float 1.0e+0  
.float 0x1.0h0x7f
```

4.4.3 String Constants

String constants begin and end with double quotation marks ("").

The assembler observes C language backslash conventions. For octal notation, the backslash conventions require three characters when the next character can be confused with the octal number. For hexadecimal notation, the backslash conventions require two characters when the next character can be confused with the hexadecimal number (that is, use a 0 for the first character of a single character hex number).

The assembler follows the backslash conventions shown in Table 9.

Table 9. Backslash Conventions

Convention	Meaning
<code>\a</code>	Alert (0x07)
<code>\b</code>	Backspace (0x08)
<code>\f</code>	Form feed (0x0c)
<code>\n</code>	Newline (0x0a)
<code>\r</code>	Carriage return (0x0d)
<code>\t</code>	horizontal tab (0x09)
<code>\v</code>	Vertical feed (0x0b)
<code>\\</code>	Backslash (0x5c)
<code>\"</code>	Double quotation mark (0x22)

Convention	Meaning
\'	Single quotation mark (0x27)
\000	Character whose octal value is 000
\Xnn	Character whose hexadecimal value is <i>nn</i>

4.5 Multiple Lines Per Physical Line

You can include multiple statements on the same line by separating the statements with semicolons. The assembler does not recognize semicolons as separators when they follow comment symbols (# or /*).

4.6 Section and Location Counters

Assembled code and data fall in one of the sections shown in Figure 1.

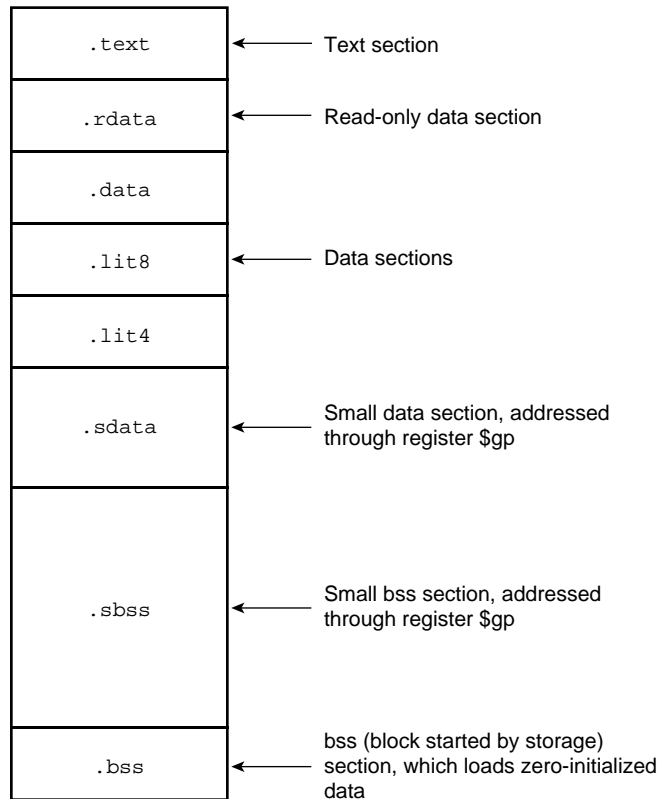

a12033

Figure 1. Section and Location Counters

The assembler always generates the `text` section before other sections. Additions to the text section happen in four-byte units. Each section has an implicit location counter, which begins at zero and increments by one for each byte assembled in the section.

The `bss` section holds zero-initialized data. If a `.lcomm` pseudo-op defines a variable (see Chapter 8, page 95), the assembler assigns that variable to the `bss` (block started by storage) section or to the `sbss` (short block started by storage) section depending on the variable's size. The default variable size for `sbss` is 8 or fewer bytes.

The command line option `-G` for each compiler (C, Pascal, Fortran 77, or the assembler), can increase the size of `sbss` to cover all but extremely large data

items. The link editor issues an error message when the `-G` value gets too large. If a `-G` value is not specified to the compiler, 8 is the default. Items smaller than, or equal to, the specified size go in `sbss`. Items greater than the specified size go in `bss`.

Because you can address items much more quickly through `$gp` than through a more general method, put as many items as possible in `sdata` or `sbss`. The size of `sdata` and `sbss` combined must not exceed 64 KB.

4.7 Statements

Each statement consists of an optional label, an operation code, and the operand(s). The system allows these statements:

- Null statements
- Keyword statements

4.7.1 Label Definitions

A label definition consists of an identifier followed by a colon. Label definitions assign the current value and type of the location counter to the name. An error results when the name is already defined, the assigned value changes the label definition, or both conditions exist.

Label definitions always end with a colon. You can put a label definition on a line by itself.

A generated label is a single numeric value (1...255). To reference a generated label, put an `f` (forward) or a `b` (backward) immediately after the digit. The reference tells the assembler to look for the nearest generated label that corresponds to the number in the lexically forward or backward direction.

4.7.2 Null Statements

A null statement is an empty statement that the assembler ignores. Null statements can have label definitions. For example, this line has three null statements in it:

```
label: ; ;
```

4.7.3 Keyword Statements

A keyword statement begins with a predefined keyword. The syntax for the rest of the statement depends on the keyword. All instruction opcodes are keywords. All other keywords are assembler pseudo-operations (directives).

4.8 Expressions

An expression is a sequence of symbols that represent a value. Each expression and its result have data types. The assembler does arithmetic in two's-complement integers (32 bits of precision in 32-bit mode; 64 bits of precision in 64-bit mode). Expressions follow precedence rules and consist of:

- Operators
- Identifiers
- Constants

Also, you may use a single character string in place of an integer within an expression. Thus:

```
.byte ``a`` ; .word ``a``+0x19
```

is equivalent to:

```
.byte 0x61 ; .word 0x7a
```

4.8.1 Precedence

Unless parentheses enforce precedence, the assembler evaluates all operators of the same precedence strictly from left to right. Because parentheses also designate index-registers, ambiguity can arise from parentheses in expressions. To resolve this ambiguity, put a unary + in front of parentheses in expressions.

The assembler has three precedence levels, which are listed here from lowest to highest precedence:

least binding, lowest precedence binary +,-

↓

↓

binary *,/,5,<<, >>, ^, &, |

↓

most binding, highest precedence unary —,+,~

Note: The assembler's precedence scheme differs from that of the C language.

4.8.2 Expression Operators

For expressions, you can rely on the precedence rules, or you can group expressions with parentheses. The assembler recognizes the operators listed in Table 10.

Table 10. Expression Operators

Operator	Meaning
+	Addition
-	Subtraction
*	Multiplication
/	Division
%	Remainder
<<	Shift Left
>>	Shift Right (sign NOT extended)
^	Bitwise Exclusive-OR
&	Bitwise AND
	Bitwise OR
-	Minus (unary)
+	Identity (unary)
~	Complement

4.8.3 Data Types

The assembler manipulates several types of expressions. Each symbol you reference or define belongs to one of the categories shown in Table 11, page 22.

Table 11. Data Types

Type	Description
<code>undefined</code>	Any symbol that is referenced but not defined becomes <i>global undefined</i> , and this module will attempt to import it. The assembler uses 32-bit addressing to access these symbols. (Declaring such a symbol in a <code>.global</code> pseudo-op merely makes its status clearer).
<code>sundefined</code>	A symbol defined by a <code>.extern</code> pseudo-op becomes <i>global small undefined</i> if its size is greater than zero but less than the number of bytes specified by the <code>-G</code> option on the command line (which defaults to 8). The linker places these symbols within a 64KB region pointed to by the <code>\$gp</code> register, so that the assembler can use economical 16-bit addressing to access them.
<code>absolute</code>	A constant defined in an "=" expression.
<code>text</code>	The <i>text</i> section contains the program's instructions, which are not modifiable during execution. Any symbol defined while the <code>.text</code> pseudo-op is in effect belongs to the text section.
<code>data</code>	The <i>data</i> section contains memory that the linker can initialize to nonzero values before your program begins to execute. Any symbol defined while the <code>.data</code> pseudo-op is in effect belongs to the data section. The assembler uses 32-bit or 64-bit addressing to access these symbols (depending on whether you are in 32-bit or 64-bit mode).
<code>sdata</code>	This category is similar to <i>data</i> , except that defining a symbol while the <code>.sdata</code> ("small data") pseudo-op is in effect causes the linker to place it within a 64KB region pointed to by the <code>\$gp</code> register, so that the assembler can use economical 16-bit addressing to access it.

Type	Description
<code>rdata</code>	Any symbol defined while the <code>.rdata</code> pseudo-op is in effect belongs to this category, which is similar to <code>data</code> , but may not be modified during execution.
<code>bss</code> and <code>sbss</code>	The <code>bss</code> and <code>sbss</code> sections consist of memory which the kernel loader initializes to zero before your program begins to execute. Any symbol defined in a <code>.comm</code> or <code>.lcomm</code> pseudo-op belongs to these sections (except that a <code>.data</code> , <code>.sdata</code> , or <code>.rdata</code> pseudo-op can override a <code>.comm</code> directive). If its size is less than the number of bytes specified by the <code>-G</code> option on the command line (which defaults to 8), it belongs to <code>sbss</code> (“small <code>bss</code> ”), and the linker places it within a 64 KB region pointed to by the <code>\$gp</code> register so that the assembler can use economical 16-bit addressing to access it. Otherwise, it belongs to <code>bss</code> and the assembler uses 32-bit or 64-bit addressing (depending on whether you are in 32-bit or 64-bit mode). Local symbols in <code>bss</code> or <code>sbss</code> defined by <code>.lcomm</code> are allocated memory by the assembler; global symbols are allocated memory by the link editor; and symbols defined by <code>.comm</code> are overlaid upon like-named symbols (in the fashion of Fortran <code>COMMON</code> blocks) by the link editor.

Symbols in the undefined and small undefined categories are always global (that is, they are visible to the link editor and can be shared with other modules of your program). Symbols in the `absolute`, `text`, `data`, `sdata`, `rdata`, `bss`, and `sbss` categories are local unless declared in a `.global` pseudo-op.

4.8.4 Type Propagation in Expressions

When expression operators combine expression operands, the result’s type depends on the types of the operands and on the operator. Expressions follow these type propagation rules:

- If an operand is undefined, the result is undefined.
- If both operands are `absolute`, the result is `absolute`.
- If the operator is `+` and the first operand refers to a relocatable `text`-section, `data`-section, `bss`-section, or an undefined external, the result has the postulated type and the other operand must be `absolute`.
- If the operator is `-` and the first operand refers to a relocatable `text`-section, `data`-section, or `bss`-section symbol, the second operand can be `absolute` (if it previously defined) and the result has the first operand’s type; or the second operand can have the same type as the first operand and the result is `absolute`. If the first operand is external undefined, the second operand must be `absolute`.

- The operators `*`, `/`, `%`, `<<`, `>>`, `~`, `^`, `&`, and `|` apply only to absolute symbols.

4.9 Relocations

With `-n32` and `-64` compiles, it is possible to specify a relocation explicitly in assembly. For example:

```
lui $24,%hi(.data)
```

This example emits a `lui$24,0` instruction with a `R_MIPS_H16` relocation that references the `.data` symbol.

The following table lists the available relocations:

<u>AS-SYNTAX</u>	<u>ELF Relocation</u>
<code>%hi</code>	<code>R_MIPS_HI16</code>
<code>%lo</code>	<code>R_MIPS_LO16</code>
<code>%gp_rel</code>	<code>R_MIPS_GPREL</code>
<code>%half</code>	<code>R_MIPS_16</code>
<code>%call6</code>	<code>R_MIPS_CALL6</code>
<code>%call_hi</code>	<code>R_MIPS_CALL_HI16</code>
<code>%call_lo</code>	<code>R_MIPS_CALL_LO16</code>
<code>%got</code>	<code>R_MIPS_GOT</code>
<code>%got_disp</code>	<code>R_MIPS_GOT_DISP</code>
<code>%got_hi</code>	<code>R_MIPS_GOT_HI16</code>
<code>%got_lo</code>	<code>R_MIPS_GOT_LO16</code>
<code>%got_page</code>	<code>R_MIPS_GOT_PAGE</code>
<code>%got_ofst</code>	<code>R_MIPS_GOT_OFST</code>
<code>%neg</code>	<code>R_MIPS_SUB</code>
<code>%higher</code>	<code>R_MIPS_HIGHER</code>
<code>%highest</code>	<code>R_MIPS_HIGHEST</code>

The Instruction Set [5]

This chapter describes instruction notation and discusses assembler instructions for the main processor. Chapter 6, page 57, describes coprocessor notation and instructions.

5.1 Instruction Classes

The assembler has these classes of instructions for the main processor:

- **Load and Store Instructions.** These instructions load immediate values and move data between memory and general registers.
- **Computational Instructions.** These instructions do arithmetic and logical operations for values in registers.
- **Jump and Branch Instructions.** These instructions change program control flow.

In addition, there are two other classes of instruction:

- **Coprocessor Interface.** These instructions provide standard interfaces to the coprocessors.
- **Special Instructions.** These instructions do miscellaneous tasks.

5.2 Reorganization Constraints and Rules

To maximize performance, the goal of RISC designs is to achieve an execution rate of one machine cycle per instruction. When writing assembly language instructions, you must be aware of the rules to achieve this goal. You can find this information in the appropriate microprocessor manual for your architecture (for example, the *MIPS R8000 Microprocessor User's Manual*).

5.3 Instruction Notation

The tables in this chapter list the assembler format for each load, store, computational, jump, branch, coprocessor, and special instruction. The format consists of an op-code and a list of operand formats. The tables list groups of closely related instructions; for those instructions, you can use any op-code with any specified operand.

Operands can take any of these formats:

- Memory references. For example, a *relocatable symbol* +/- an *expression(register)*.
- Expressions (for immediate values).
- Two or three operands. For example, `ADD $3, $4` is the same as `ADD $3, $3, $4`.

The operands in the table in this chapter have the following meanings

<u>Operand</u>	<u>Description</u>
address	Symbolic expression (see Chapter 2)
breakcode	Value that determines the break
destination	Destination register
destination/src1	Destination register is also source register 1
dest-copr	Destination coprocessor register
dest-gpr	Destination general register
expression	Absolute value
immediate	Expression with an immediate value
label	Symbolic label
operation	Coprocessor-specific operation
return	Register containing the return address
source	Source register
src1, src2	Source registers
src-copr	Coprocessor register from which values are assigned
src-gpr	General register from which values are assigned
target	Register containing the target

z

Coprocesor number in the range 0..2

5.4 Instruction Set

The tables in this section summarize the assembly language instruction set. Most of the assembly language instructions have direct machine equivalents.

5.4.1 Load and Store Instructions

Load and store are immediate type intructions that move data between memory and the general registers. Table 12 summarizes the load and store instruction format, and Table 13 and Table 14 provide more detailed descriptions for each load instruction. Table 15, page 32, and Table 16, page 34, provide details of each store instruction.

Table 12. Load and Store Format Summary

Description	Op-code	Operands
Load Address	LA	<i>destination, address</i>
Load Doubleword Address	DLA	
Load Byte	LB	
Load Byte Unsigned	LBU	
Load Halfword	LH	
Load Halfword Unsigned	LHU	
Load Linked *	LL	
Load Word	LW	
Load Word Left	LWL	
Load Word Right	LWR	
Load Doubleword	LD	
Unaligned Load Halfword	ULH	
Unaligned Load Halfword Unsigned	ULHU	
Unaligned Load Word	ULW	

Description	Op-code	Operands
Load Immediate	LI	<i>destination, expression</i>
Load Doubleword Immediate	DLI	
Store Double Right	SDR	
Unaligned Store Doubleword	USD	
Load Upper Immediate	LUI	
Store Byte	SB	<i>source, address</i>
Store Conditional *	SC	
Store Double	SD	
Store Halfword	SH	
Store Word Left	SWL	
Store Word Right	SWR	
Store Word	SW	
Unaligned Store Halfword	USH	
Unaligned Store Word	USW	
Load Doubleword	LD	<i>destination, address</i>
Load Linked Doubleword	LLD	
Load Word Unsigned	LWU	
Load Doubleword Left	LDL	
Load Doubleword Right	LDR	
Unaligned Load Double	ULD	
Store Doubleword	SD	<i>source, address</i>
Store Conditional Doubleword	SCD	
Store Double Left	SDL	

* not valid in MIPS1 architecture

5.4.2 Load Instruction Descriptions

For all load instructions, the effective address is the 32-bit twos-complement sum of the contents of the index-register and the (sign-extended) 16-bit offset. Instructions that have symbolic labels imply an index register, which the

assembler determines. The assembler supports additional load instructions, which can produce multiple machine instructions.

Note: Load instructions can generate many code sequences for which the link editor must fix the address by resolving external data items.

Table 13. Load Instruction Descriptions

Instruction Name	Description
Load Address (LA)	Loads the destination register with the effective 32-bit address of the specified data item.
Load Doubleword Address (DLA)	Loads the destination register with the effective 64-bit address of the specified data item (MIPS3 and above only).
Load Byte (LB)	Loads the least-significant byte of the destination register with the contents of the byte that is at the memory location specified by the effective address. The system treats the loaded byte as a signed value: bit seven is extended to fill the three most-significant bytes.
Load Byte Unsigned (LBU)	Loads the least-significant byte of the destination register with the contents of the byte that is at the memory location specified by the effective address. Because the system treats the loaded byte as an unsigned value, it fills the three most-significant bytes of the destination register with zeros.
Load Halfword (LH)	Loads the two least-significant bytes of the destination register with the contents of the halfword that is at the memory location specified by the effective address. The system treats the loaded halfword as a signed value. If the effective address is not even, the system signals an address error exception.
Load Halfword Unsigned (LHU)	Loads the least-significant bits of the destination register with the contents of the halfword that is at the memory location specified by the effective address. Because the system treats the loaded halfword as an unsigned value, it fills the two most-significant bytes of the destination register with zeros. If the effective address is not even, the system signals an address error exception.

Instruction Name	Description
Load Linked (LL)	<p>Loads the destination register with the contents of the word that is at the memory location. This instruction performs an SYNC operation implicitly; all loads and stores to shared memory fetched prior to the LL must access memory before the LL, and loads and stores to shared memory fetched subsequent to the LL must access memory after the LL. Load Linked and Store Conditional can be use to update memory locations atomically. The system signals an address exception when the effective address is not divisible by four.</p> <p>This instruction is not valid in the MIPS1 architectures.</p>
Load Word (LW)	<p>Loads the destination register with the contents of the word that is at the memory location. The system replaces all bytes of the register with the contents of the loaded word. The system signals an address error exception when the effective address is not divisible by four.</p>
Load Word Left (LWL)	<p>Loads the sign; that is, Load Word Left loads the destination register with the most-significant bytes of the word specified by the effective address. The effective address must specify the byte containing the sign. In a big-endian system, the effective address specifies the lowest numbered byte; in a little-endian system, the effective address specifies the highest numbered byte. Only the bytes which share the same aligned word in memory are merged into the destination register.</p>
Load Word Right (LWR)	<p>Loads the lowest precision bytes; that is, Load Word Right loads the destination register with the least-significant bytes of the word specified by the effective address. The effective address must specify the byte containing the least-significant bits. In a big-endian configuration, the effective address specifies the highest numbered byte; in a little-endian configuration, the effective address specifies the lowest numbered byte. Only the bytes which share the same aligned word in memory are merged into the destination register.</p>
Load Doubleword (LD)	<p>LD is a machine instruction in the MIPS3 architecture. For the <code>-mips1</code> [default] and <code>-mips2</code> option: Loads the register pair (<i>destination</i> and <i>destination +1</i>) with the two successive words specified by the address. The destination register must be the even register of the pair. When the address is not on a word boundary, the system signals an address error exception.</p> <p>Note: This is retained for use with the <code>-mips1</code> and <code>-mips2</code> options to provide backward compatibility only.</p>
Unaligned Load Halfword (ULH)	<p>Loads a halfword into the destination register from the specified address and extends the sign of the halfword. Unaligned Load Halfword loads a halfword regardless of the halfword's alignment in memory.</p>

Instruction Name	Description
Unaligned Load Halfword Unsigned (ULHU)	Loads a halfword into the destination register from the specified address and zero extends the halfword. Unaligned Load Halfword Unsigned loads a halfword regardless of the halfword's alignment in memory.
Unaligned Load Word (ULW)	Loads a word into the destination register from the specified address. Unaligned Load Word loads a word regardless of the word's alignment in memory.
Load Immediate (LI)	Loads the destination register with the 32-bit value of an expression that can be computed at assembly time. Note: Load Immediate can generate any efficient code sequence to put a desired value in the register.
Load Doubleword Immediate (DLI)	Loads the destination register with the 64-bit value of an expression that can be computed at assembly time. Note: Load Immediate can generate any efficient code sequence to put a desired value in the register (MIPS3 and above only).
Load Upper Immediate (LUI)	Loads the most-significant half of a register with the expression's value. The system fills the least-significant half of the register with zeros. The expression's value must be in the range $-32768...65535$.

Table 14. Load Instruction Descriptions for MIPS3/4 Architecture Only

Instruction Name	Description
Load Doubleword (LD)	Loads the destination register with the contents of the doubleword that is at the memory location. The system replaces all bytes of the register with the contents of the loaded doubleword. The system signals an address error exception when the effective address is not divisible by eight.
Load Linked Doubleword (LLD)	Loads the destination register with the contents of the doubleword that is currently in the memory location. This instruction performs a SYNC operation implicitly. Load Linked Doubleword and Store Conditional Doubleword can be used to update memory locations atomically.

Instruction Name	Description
Load Word Unsigned(LWU)	Loads the least-significant bits of the destination register with the contents of the word (32 bits) that is at the memory location specified by the effective address. Because the system treats the loaded word as an unsigned value, it fills the four most-significant bytes of the destination register with zeros. If the effective address is not divisible by four, the system signals an address error exception.
Load Doubleword Left (LDL)	Loads the destination register with the most-significant bytes of the doubleword specified by the effective address. The effective address must specify the byte containing the sign. In a big-endian configuration, the effective address specifies the lowest numbered byte; in a little-endian machine, the effective address specifies the highest numbered byte. Only the bytes which share the same aligned doubleword in memory are merged into the destination register.
Load Doubleword Right (LDR)	Loads the destination register with the least-significant bytes of the doubleword specified by the effective address. The effective address must specify the byte containing the least-significant bits. In a big-endian machine, the effective address specifies the highest numbered byte. In a little-endian machine, the effective address specifies the lowest numbered byte. Only the bytes which share the same aligned doubleword in memory are merged into the destination register.
Unaligned Load Doubleword (ULD)	Loads a doubleword into the destination register from the specified address. ULD loads a doubleword regardless of the doubleword's alignment in memory.

5.4.3 Store Instruction Descriptions

For all machine store instructions, the effective address is the 32-bit two's-complement sum of the contents of the index-register and the (sign-extended) 16-bit offset. The assembler supports additional store instructions, which can produce multiple machine instructions. Instructions that have symbolic labels imply an index-register, which the assembler determines.

Table 15. Store Instruction Descriptions

Instruction Name	Description
Store Byte (SB)	Stores the contents of the source register's least-significant byte in the byte specified by the effective address.
Store Conditional (SC)	Stores the contents of a word from the source register into the memory location specified by the effective address. This instruction implicitly performs a SYNC operation; all loads and stores to shared memory fetched prior to the sc must access memory before the sc, and loads and stores to shared memory fetched subsequent to the sc must access memory after the sc. If any other processor or device has modified the physical address since the time of the previous Load Linked instruction, or if an RFE or ERET instruction occurs between the Load Linked and this store instruction, the store fails. The success or failure of the store operation (as defined above) is indicated by the contents of the source register after execution of the instruction. A successful store sets it to 1; and a failed store sets it to 0. The machine signals an address exception when the effective address is not divisible by four. This instruction is not valid in the MIPS1 architectures.
Store Doubleword (SD)	SD is a machine instruction in the MIPS3 architecture. For the <code>-mips1</code> [default] and <code>-mips2</code> options: Stores the contents of the register pair in successive words, which the address specifies. The source register must be the even register of the pair, and the storage address must be word aligned. Note: This is retained for use with the <code>-mips1</code> and <code>-mips2</code> options to provide backward compatibility only.
Store Halfword (SH)	Stores the two least-significant bytes of the source register in the halfword that is at the memory location specified by the effective address. The effective address must be divisible by two; otherwise the machine signals an address error exception.
Store Word Left (SWL)	Stores the most-significant bytes of a word in the memory location specified by the effective address. The contents of the word at the memory location, specified by the effective address, are shifted right so that the leftmost byte of the unaligned word is in the addressed byte position. The stored bytes replace the corresponding bytes of the effective address. The effective address's last two bits determine how many bytes are involved.

Instruction Name	Description
Store Word Right (SWR)	Stores the least-significant bytes of a word in the memory location specified by the effective address. The contents of the word at the memory location, specified by the effective address, are shifted left so that the right byte of the unaligned word is in the addressed byte position. The stored bytes replace the corresponding bytes of the effective address. The effective address's last two bits determine how many bytes are involved.
Store Word (SW)	Stores the contents of a word from the source register in the memory location specified by the effective address. The effective address must be divisible by four; otherwise the machine signals an address error exception.
Unaligned Store Halfword (USH)	Stores the contents of the two least-significant bytes of the source register in a halfword that the address specifies. The machine does not require alignment for the storage address.
Unaligned Store Word (USW)	Stores the contents of the source register in a word specified by the address. The machine does not require alignment for the storage address.

Table 16. Store Instruction Descriptions for MIPS3/4 Architecture Only

Instruction Name	Description
Store Doubleword (SD)	Stores the contents of a doubleword from the source register in the memory location specified by the effective address. The effective address must be divisible by eight, otherwise the machine signals an address error exception.
Store Conditional Doubleword (SCD)	Stores the contents of a doubleword from the source register into the memory locations specified by the effective address. This instruction implicitly performs a SYNC operation. If any other processor or device has modified the physical address since the time of the previous Load Linked instruction, or if an ERET instruction occurs between the Load Linked instruction and this store instruction, the store fails and is inhibited from taking place. The success or failure of the store operation (as defined above) is indicated by the contents of the source register after execution of this instruction. A successful store sets it to 1; and a failed store sets it to 0. The machine signals an address exception when the effective address is not divisible by eight.
Store Doubleword Left (SDL)	Stores the most-significant bytes of a doubleword in the memory location specified by the effective address. It alters only the doubleword in memory which contains the byte indicated by the effective address.

Instruction Name	Description
Store Doubleword Right (SDR)	Stores the least-significant bytes of a doubleword in the memory location specified by the effective address. It alters only the doubleword in memory which contains the byte indicated by the effective address.
Unaligned Store Doubleword (USD)	Stores the contents of the source register in a doubleword specified by the address. The machine does not require alignment for the storage address.

5.5 Computational Instructions

The machine has general-purpose and coprocessor-specific computational instructions (for example, the floating-point coprocessor). This section describes general-purpose computational instructions.

5.5.1 Computational Instructions

Computational instructions perform the following operations on register values;

- arithmetic
- logical
- shift
- multiply
- divide

Table 17 summarizes the computational format summaries, and Table 18, page 38, and Table 19, page 44, describe these instructions in more detail.

Table 17. Computational Format Summaries

Description	Op-code	Operand
Add with Overflow	ADD	<i>destination, src1, src2</i>
Add without Overflow	ADDU	<i>destination, src1, src2</i>
AND	AND	<i>destination, src1, immediate</i>
Divide Signed	DIV	<i>destination / src1, immediate</i>

Description	Op-code	Operand
Divide Unsigned	DIVU	
Exclusive-OR	XOR	
Multiply	MUL	
Multiply with Overflow	MULO	
Multiply with Overflow Unsigned	MULOU	
NOT OR	NOR	
OR	OR	
Set Equal	SEQ	
Set Greater Than	SGT	
Set Greater/Equal	SGE	
Set Greater/Equal Unsigned	SGEU	
Set Greater Unsigned	SGTU	
Set Less Than	SLT	
Set Less/Equal	SLE	
Set Less/Equal Unsigned	SLEU	
Set Less Than Unsigned	SLTU	
Set Not Equal	SNE	
Subtract with Overflow	SUB	
Subtract without Overflow	SUBU	
Remainder Signed	REM	
Remainder Unsigned	REMU	
Rotate Left	ROL	
Rotate Right	ROR	
Shift Right Arithmetic	SRA	
Shift Left Logical	SLL	
Shift Right Logical	SRL	
Absolute Value	ABS	<i>destination, src1</i>
Negate with Overflow	NEG	<i>destination /src1</i>

Description	Op-code	Operand
Negate without Overflow	NEGU	
NOT	NOT	
Move	MOVE	<i>destination, src1</i>
Move Conditional on Not Zero	MOVN	<i>destination, src1, src2</i>
Move Conditional on Zero	MOVZ	
Multiply	MULT	<i>src1,src2</i>
Multiply Unsigned	MULTU	
Trap if Equal	TEQ	<i>src1, src2</i>
Trap if not Equal	TNE	<i>src1, immediate</i>
Trap if Less Than	TLT	
Trap if Less than, Unsigned	TLTU	
Trap if Greater Than or Equal	TGE	
Trap if Greater than or Equal, Unsigned	TGEU	
Doubleword Add with Overflow	DADD	<i>destination,src1, src2</i> <i>destination /src1,src2</i>
Doubleword Add without Overflow	DADDU	<i>destination, src1, immediate</i> <i>destination /src1, immediate</i>
Doubleword Divide Signed	DDIV	
Doubleword Divide Unsigned	DDIVU	
Doubleword Multiply	DMUL	
Doubleword Multiply with Overflow	DMULO	
Doubleword Multiply with Overflow Unsigned	DMULOU	
Doubleword Subtract with Overflow	DSUB	
Doubleword Subtract without Overflow	DSUBU	
Doubleword Remainder Signed	DREM	
Doubleword Remainder Unsigned	DREMU	
Doubleword Rotate Left	DROL	
Doubleword Rotate Right	DROR	
Doubleword Shift Right Arithmetic	DSRA	

Description	Op-code	Operand
Doubleword Shift Left Logical	DSLL	
Doubleword Shift Right Logical	DSRL	
Doubleword Absolute Value	DABS	<i>destination, src1</i>
Doubleword Negate with Overflow	DNEG	<i>destination/src1</i>
Doubleword Negate without Overflow	DNEGU	
Doubleword Multiply	DMULT	<i>src1, src2</i>
Doubleword Multiply Unsigned	DMULTU	<i>src1, immediate</i>

5.5.2 Computational Instruction Descriptions

Table 18. Computational Instruction Descriptions

Instruction Name	Description
Absolute Value (ABS)	Computes the absolute value of the contents of <i>src1</i> and puts the result in the destination register. If the value in <i>src1</i> is -2147483648 , the machine signals an overflow exception.
Add with Overflow (ADD)	Computes the twos-complement sum of two signed values. This instruction adds the contents of <i>src1</i> to the contents of <i>src2</i> , or it can add the contents of <i>src1</i> to the immediate value. Add (with Overflow) puts the result in the destination register. When the result cannot be extended as a 32-bit number, the machine signals an overflow exception.
Add without Overflow (ADDU)	Computes the twos-complement sum of two 32-bit values. This instruction adds the contents of <i>src1</i> to the contents of <i>src2</i> , or it can add the contents of <i>src1</i> to the immediate value. Add (without Overflow) puts the result in the destination register. Overflow exceptions never occur.
AND (AND)	Computes the Logical AND of two values. This instruction ANDs (bit-wise) the contents of <i>src1</i> with the contents of <i>src2</i> , or it can AND the contents of <i>src1</i> with the immediate value. The immediate value is not sign extended. AND puts the result in the destination register.

Instruction Name	Description
Divide Signed (DIV)	<p>Computes the quotient of two values. Divide (with Overflow) treats <i>src1</i> as the dividend. The divisor can be <i>src2</i> or the immediate value. The instruction divides the contents of <i>src1</i> by the contents of <i>src2</i>, or it can divide <i>src1</i> by the immediate value. It puts the quotient in the destination register. If the divisor is zero, the machine signals an error and may issue a BREAK instruction. The DIV instruction rounds toward zero. Overflow is signaled when dividing -2147483648 by -1. The machine may issue a BREAK instruction for divide-by-zero or for overflow.</p> <p>Note: The special case <code>DIV \$0,<i>src1</i>,<i>src2</i></code> generates the real machine divide instruction and leaves the result in the HI/LO register. The HI register contains the remainder and the LO register contains the quotient. No checking for divide-by-zero is performed.</p>
Divide Unsigned (DIVU)	<p>Computes the quotient of two unsigned 32-bit values. Divide (unsigned) treats <i>src1</i> as the dividend. The divisor can be <i>src2</i> or the immediate value. This instruction divides the contents of <i>src1</i> by the contents of <i>src2</i>, or it can divide the contents of <i>src1</i> by the immediate value. Divide (unsigned) puts the quotient in the destination register. If the divisor is zero, the machine signals an exception and may issue a BREAK instruction. See the note for DIV concerning \$0 as a destination. Overflow exceptions never occur.</p>
Exclusive-OR (XOR)	<p>Computes the XOR of two values. This instruction XORs (bit-wise) the contents of <i>src1</i> with the contents of <i>src2</i>, or it can XOR the contents of <i>src1</i> with the immediate value. The immediate value is not sign extended. Exclusive-OR puts the result in the destination register.</p>
Move (MOVE)	<p>Moves the contents of <i>src1</i> to the destination register.</p>
Move Conditional on Not Zero (MOVN)	<p>Conditionally moves the contents of <i>src1</i> to the destination register after testing that <i>src2</i> is not equal to zero (MIPS4 only.)</p>
Move Conditional on Zero (MOVZ)	<p>Conditionally moves the contents of <i>src1</i> to the destination register after testing that <i>src2</i> is equal to zero (MIPS4 only).</p>
Multiply (MUL)	<p>Computes the product of two values. This instruction puts the 32-bit product of <i>src1</i> and <i>src2</i>, or the 32-bit product of <i>src1</i> and the immediate value, in the destination register. The machine does not report overflow.</p> <p>Note: Use MUL when you do not need overflow protection: it's often faster than MULO and MULO. For multiplication by a constant, the MUL instruction produces faster machine instruction sequences than MULT or MULTU instructions can produce.</p>

Instruction Name	Description
Multiply (MULT)	<p>Computes the 64-bit product of two 32-bit signed values. This instruction multiplies the contents of <i>src1</i> by the contents of <i>src2</i> and puts the result in the HI and LO registers (see Chapter 1). No overflow is possible.</p> <p>Note: The MULT instruction is a real machine language instruction.</p>
Multiply Unsigned (MULTU)	<p>Computes the product of two unsigned 32-bit values. It multiplies the contents of <i>src1</i> and the contents of <i>src2</i> and puts the result in the HI and LO registers (see Chapter 1). No overflow is possible.</p> <p>Note: The MULTU instruction is a real machine language instruction.</p>
Multiply with Overflow (MULO)	<p>Computes the product of two 32-bit signed values. Multiply (with Overflow) puts the 32-bit product of <i>src1</i> and <i>src2</i>, or the 32-bit product of <i>src1</i> and the immediate value, in the destination register. When an overflow occurs, the machine signals an overflow exception and may execute a BREAK instruction.</p> <p>Note: For multiplication by a constant, MULO produces faster machine instruction sequences than MULT or MULTU can produce; however, if you do not need overflow detection, use the MUL instruction. It's often faster than MULO.</p>
Multiply with Overflow Unsigned (MULOU)	<p>Computes the product of two 32-bit unsigned values. Multiply (with Overflow Unsigned) puts the 32-bit product of <i>src1</i> and <i>src2</i>, or the product of <i>src1</i> and the immediate value, in the destination register. This instruction treats the multiplier and multiplicand as 32-bit unsigned values. When an overflow occurs, the machine signals an overflow exception and may issue an BREAK instruction.</p> <p>Note: For multiplication by a constant, MULOU produces faster machine instruction sequences than MULT or MULTU can reproduce; however, if you do not need overflow detection, use the MUL instruction. It's often faster than MULOU.</p>
Negate with Overflow (NEG)	<p>Computes the negative of a value. This instruction negates the contents of <i>src1</i> and puts the result in the destination register. If the value in <i>src1</i> is -2147483648, the machine signals an overflow exception.</p>
Negate without Overflow (NEGU)	<p>Negates the integer contents of <i>src1</i> and puts the result in the destination register. The machine does not report overflows.</p>
NOT (NOT)	<p>Computes the Logical NOT of a value. This instruction complements (bit-wise) the contents of <i>src1</i> and puts the result in the destination register.</p>

Instruction Name	Description
NOT OR (NOR)	Computes the NOT OR of two values. This instruction combines the contents of <i>src1</i> with the contents of <i>src2</i> (or the immediate value). NOT OR complements the result and puts it in the destination register.
OR (OR)	Computes the Logical OR of two values. This instruction ORs (bit-wise) the contents of <i>src1</i> with the contents of <i>src2</i> , or it can OR the contents of <i>src1</i> with the immediate value. The immediate value is not sign-extended. OR puts the result in the destination register.
Remainder Signed (REM)	Computes the remainder of the division of two unsigned 32-bit values. The machine defines the remainder $REM(i,j)$ as $i - (j * \text{div}(i,j))$ where $j \neq 0$. Remainder (with Overflow) treats <i>src1</i> as the dividend. The divisor can be <i>src2</i> or the immediate value. This instruction divides the contents of <i>src1</i> by the contents of <i>src2</i> , or it can divide the contents of <i>src1</i> by the immediate value. It puts the remainder in the destination register. The REM instruction rounds toward zero, rather than toward negative infinity. For example, $\text{div}(5,-3)=-1$, and $\text{rem}(5,-3)=2$. For divide-by-zero, the machine signals an error and may issue a BREAK instruction.
Remainder Unsigned (REMU)	Computes the remainder of the division of two unsigned 32-bit values. The machine defines the remainder $REM(i,j)$ as $i - (j * \text{div}(i,j))$ where $j \neq 0$. Remainder (unsigned) treats <i>src1</i> as the dividend. The divisor can be <i>src2</i> or the immediate value. This instruction divides the contents of <i>src1</i> by the contents of <i>src2</i> , or it can divide the contents of <i>src1</i> by the immediate value. Remainder (unsigned) puts the remainder in the destination register. For divide-by-zero, the machine signals an error and may issue a BREAK instruction.
Rotate Left (ROL)	Rotates the contents of a register left (toward the sign bit). This instruction inserts in the least-significant bit any bits that were shifted out of the sign bit. The contents of <i>src1</i> specify the value to shift, and the contents of <i>src2</i> (or the immediate value) specify the amount to shift. Rotate Left puts the result in the destination register. If <i>src2</i> (or the immediate value) is greater than 31, <i>src1</i> shifts by (<i>src2</i> MOD 32).
Rotate Right (ROR)	Rotates the contents of a register right (toward the least-significant bit). This instruction inserts in the sign bit any bits that were shifted out of the least-significant bit. The contents of <i>src1</i> specify the value to shift, and the contents of <i>src2</i> (or the immediate value) specify the amount to shift. Rotate Right puts the result in the destination register. If <i>src2</i> (or the immediate value) is greater than 32, <i>src1</i> shifts by <i>src2</i> MOD 32.

Instruction Name	Description
Set Equal (SEQ)	Compares two 32-bit values. If the contents of <i>src1</i> equal the contents of <i>src2</i> (or <i>src1</i> equals the immediate value) this instruction sets the destination register to one; otherwise, it sets the destination register to zero.
Set Greater Than (SGT)	Compares two signed 32-bit values. If the contents of <i>src1</i> are greater than the contents of <i>src2</i> (or <i>src1</i> is greater than the immediate value), this instruction sets the destination register to one; otherwise, it sets the destination register to zero.
Set Greater/Equal (SGE)	Compares two signed 32-bit values. If the contents of <i>src1</i> are greater than or equal to the contents of <i>src2</i> (or <i>src1</i> is greater than or equal to the immediate value), this instruction sets the destination register to one; otherwise, it sets the destination register to zero.
Set Greater/Equal Unsigned (SGEU)	Compares two unsigned 32-bit values. If the contents of <i>src1</i> are greater than or equal to the contents of <i>src2</i> (or <i>src1</i> is greater than or equal to the immediate value), this instruction sets the destination register to one; otherwise, it sets the destination register to zero.
Set Greater Than Unsigned (SGTU)	Compares two unsigned 32-bit values. If the contents of <i>src1</i> are greater than the contents of <i>src2</i> (or <i>src1</i> is greater than the immediate value), this instruction sets the destination register to one; otherwise, it sets the destination register to zero.
Set Less Than (SLT)	Compares two signed 32-bit values. If the contents of <i>src1</i> are less than the contents of <i>src2</i> (or <i>src1</i> is less than the immediate value), this instruction sets the destination register to one; otherwise, it sets the destination register to zero.
Set Less/Equal (SLE)	Compares two signed 32-bit values. If the contents of <i>src1</i> are less than or equal to the contents of <i>src2</i> (or <i>src1</i> is less than or equal to the immediate value), this instruction sets the destination register to one; otherwise, it sets the destination register to zero.
Set Less/Equal Unsigned (SLEU)	Compares two unsigned 32-bit values. If the contents of <i>src1</i> are less than or equal to the contents of <i>src2</i> (or <i>src1</i> is less than or equal to the immediate value) this instruction sets the destination register to one; otherwise, it sets the destination register to zero.
Set Less Than Unsigned (SLTU)	Compares two unsigned 32-bit values. If the contents of <i>src1</i> are less than the contents of <i>src2</i> (or <i>src1</i> is less than the immediate value), this instruction sets the destination register to one; otherwise, it sets the destination register to zero.

Instruction Name	Description
Set Not Equal (SNE)	Compares two 32-bit values. If the contents of <i>src1</i> do not equal the contents of <i>src2</i> (or <i>src1</i> does not equal the immediate value), this instruction sets the destination register to one; otherwise, it sets the destination register to zero.
Shift Left Logical (SLL)	Shifts the contents of a register left (toward the sign bit) and inserts zeros at the least-significant bit. The contents of <i>src1</i> specify the value to shift, and the contents of <i>src2</i> or the immediate value specify the amount to shift. If <i>src2</i> (or the immediate value) is greater than 31 or less than 0, <i>src1</i> shifts by $src2 \text{ MOD } 32$.
Shift Right Arithmetic (SRA)	Shifts the contents of a register right (toward the least-significant bit) and inserts the sign bit at the most-significant bit. The contents of <i>src1</i> specify the value to shift, and the contents of <i>src2</i> (or the immediate value) specify the amount to shift. If <i>src2</i> (or the immediate value) is greater than 31 or less than 0, <i>src1</i> shifts by the result of $src2 \text{ MOD } 32$.
Shift Right Logical (SRL)	Shifts the contents of a register right (toward the least-significant bit) and inserts zeros at the most-significant bit. The contents of <i>src1</i> specify the value to shift, and the contents of <i>src2</i> (or the immediate value) specify the amount to shift. If <i>src2</i> (or the immediate value) is greater than 31 or less than 0, <i>src1</i> shifts by the result of $src2 \text{ MOD } 32$.
Subtract with Overflow (SUB)	Computes the twos-complement difference for two signed values. This instruction subtracts the contents of <i>src2</i> from the contents of <i>src1</i> , or it can subtract the contents of the immediate from the <i>src1</i> value. Subtract (with Overflow) puts the result in the destination register. When the true result's sign differs from the destination register's sign, the machine signals an overflow exception.
Subtract without Overflow (SUBU)	Computes the twos-complement difference for two 32-bit values. This instruction subtracts the contents of <i>src2</i> from the contents of <i>src1</i> , or it can subtract the contents of the immediate from the <i>src1</i> value. Subtract (without Overflow) puts the result in the destination register. Overflow exceptions never happen.
Trap if Equal (TEQ)	Compares two 32-bit values. If the contents of <i>src1</i> equal the contents of <i>src2</i> (or <i>src1</i> equals the immediate value), a trap exception occurs.
Trap if Not Equal (TNE)	Compares two 32-bit values. If the contents of <i>src1</i> do not equal the contents of <i>src2</i> (or <i>src1</i> does not equal the immediate value), a trap exception occurs.
Trap if Less Than (TLT)	Compares two signed 32-bit values. If the contents of <i>src1</i> are less than the contents of <i>src2</i> (or <i>src1</i> is less than the immediate value), a trap exception occurs.

Instruction Name	Description
Trap if Less Than Unsigned (TLTU)	Compares two unsigned 32-bit values. If the contents of <i>src1</i> are less than the contents of <i>src2</i> (or <i>src1</i> is less than the immediate value), a trap exception occurs.
Trap if Greater than or Equal (TGE)	Compares two signed 32-bit values. If the contents of <i>src1</i> are greater than the contents of <i>src2</i> (or <i>src1</i> is greater than the immediate value), a trap exception occurs.
Trap if Greater than or Equal Unsigned (TGEU)	Compares two unsigned 32-bit values. If the contents of <i>src1</i> are greater than the contents of <i>src2</i> (or <i>src1</i> is greater than the immediate value), a trap exception occurs.

Table 19. Computational Instruction Descriptions for MIPS3/4 Architecture

Instruction Name	Description
Doubleword Absolute Value (DABS)	Computes the absolute value of the contents of <i>src1</i> , treated as a 64-bit signed value, and puts the result in the destination register. If the value in <i>src1</i> is -2^{63} , the machine signals an overflow exception.
Doubleword Add with Overflow (DADD)	Computes the twos-complement sum of two 64-bit signed values. The instruction adds the contents of <i>src1</i> to the contents of <i>src2</i> , or it can add the contents of <i>src1</i> to the immediate value. When the result cannot be extended as a 64-bit number, the system signals an overflow exception.
Doubleword Add without Overflow (DADDU)	Computes the twos-complement sum of two 64-bit values. The instruction adds the contents of <i>src1</i> to the contents of <i>src2</i> , or it can add the contents of <i>src1</i> to the immediate value. Overflow exceptions never occur.
Doubleword Divide Signed (DDIV)	Computes the quotient of two 64-bit values. DDIV treats <i>src1</i> as the dividend. The divisor can be <i>src2</i> or the immediate value. It puts the quotient in the destination register. If the divisor is zero, the system signals an error and may issue a BREAK instruction. The DDIV instruction rounds towards zero. Overflow is signaled when dividing -2^{63} by -1 . Note: The special case DDIV $\$0,src1,src2$ generates the real doubleword divide instruction and leaves the result in the HI/LO register. The HI register contains the quotient. No checking for divide-by-zero is performed.

Instruction Name	Description
Doubleword Divide Unsigned (DDIVU)	Computes the quotient of two unsigned 64-bit values. DDIVU treats <i>src1</i> as the dividend. The divisor can be <i>src2</i> or the immediate value. It puts the quotient in the destination register. If the divisor is zero, the system signals an exception and may issue a BREAK instruction. See note for DDIV concerning \$0 as a destination. Overflow exceptions never occur.
Doubleword Multiply (DMUL)	<p>Computes the product of two values. This instruction puts the 64-bit product of <i>src1</i> and <i>src2</i>, or the 64-bit product of <i>src1</i> and the immediate value, in the destination register. Overflow is not reported.</p> <p>Note: Use DMUL when you do not need overflow protection. It is often faster than DMULO and DMULOU. For multiplication by a constant, the DMUL instruction produces faster machine instruction sequences than DMULT or DMULTU can produce.</p>
Doubleword Multiply (DMULT)	<p>Computes the 128-bit product of two 64-bit signed values. This instruction multiplies the contents of <i>src1</i> by the contents of <i>src2</i> and puts the result in the HI and LO registers. No overflow is possible.</p> <p>Note: The DMULT instruction is a real machine language instruction.</p>
Doubleword Multiply Unsigned (DMULTU)	<p>Computes the product of two unsigned 64-bit values. It multiplies the contents of <i>src1</i> and the contents of <i>src2</i>, putting the result in the HI and LO registers. No overflow is possible.</p> <p>Note: The DMULTU instruction is a real machine language instruction.</p>
Doubleword Multiply with Overflow (DMULO)	<p>Computes the product of two 64-bit signed values. It puts the 64-bit product of <i>src1</i> and <i>src2</i>, or the 64-bit product of <i>src1</i> and the immediate value, in the destination register. When an overflow occurs, the system signals an overflow exception and may execute a BREAK instruction.</p> <p>Note: For multiplication by a constant, DMULO produces faster machine instruction sequences than DMULT or DMULTU can produce; however, if you do not need overflow detection, use the DMUL instruction. It is often faster than DMULO.</p>

Instruction Name	Description
Doubleword Multiply with Overflow Unsigned (DMULOU)	<p>Computes the product of two 64-bit unsigned values. It puts the 64-bit product of <i>src1</i> and <i>src2</i>, or the 64-bit product of <i>src1</i> and the immediate value, into the destination register. When an overflow occurs, the system signals an overflow exception and may issue a BREAK instruction.</p> <p>Note: For multiplication by a constant, DMULO produces faster machine instruction sequences than DMULT or DMULTU can produce; however, if you do not need overflow detection, use the DMUL instruction. It is often faster than DMULO.</p>
Doubleword Negate with Overflow (DNEG)	Computes the negative of a 64-bit value. The instruction negates the contents of <i>src1</i> and puts the result in the destination register. If the value of <i>src1</i> is -2^{63} , the system signals an overflow exception.
Doubleword Negate without Overflow (DNEGU)	Negates the 64-bit contents of <i>src1</i> and puts the result in the destination register. Overflow is not reported.
Doubleword Remainder Signed (DREM)	Computes the remainder of the division of two signed 64-bit values. It treats <i>src1</i> as the dividend. The divisor can be <i>src2</i> or the immediate value. The DREMU instruction puts the remainder in the destination register. If the divisor is zero, the system signals an error and may issue a BREAK instruction.
Doubleword Remainder Unsigned (DREMU)	Computes the remainder of the division of two unsigned 64-bit values. It treats <i>src1</i> as the dividend. The divisor can be <i>src2</i> or the immediate value. The DREMU instruction puts the remainder in the destination register. If the divisor is zero, the system signals an error and may issue a BREAK instruction.
Doubleword Rotate Left (DROL)	Rotates the contents of a 64-bit register left (towards the sign bit). This instruction inserts in the least-significant bit any bits that were shifted out of the sign bit. The contents of <i>src1</i> specify the value to shift, and contents of <i>src2</i> (or the immediate value) specify the amount to shift. If <i>src2</i> (or the immediate value) is greater than 63, <i>src1</i> shifts by $src2 \text{ MOD } 64$.
Doubleword Rotate Right (DROR)	Rotates the contents of a 63-bit register right (towards the least-significant bit). This instruction inserts in the sign bit any bits that were shifted out of the least-significant bit. The contents of <i>src1</i> specify the value to shift, and the contents of <i>src2</i> (or the immediate value) specify the amount to shift. If <i>src2</i> (or the immediate value) is greater than 63, <i>src1</i> shifts by $src2 \text{ MOD } 64$.

Instruction Name	Description
Doubleword Shift Left Logical (DSL) (DSL)	Shifts the contents of a 64-bit register left (towards the sign bit) and inserts zeros at the least-significant bit. The contents of <i>src1</i> specify the value to shift, and the contents of <i>src2</i> (or the immediate value) specify the amount to shift. If <i>src2</i> (or the immediate value) is greater than 63, <i>src1</i> shifts by <i>src2</i> MOD 64.
Doubleword Shift Right Arithmetic (DSRA)	Shifts the contents of a 64-bit register right (towards the least-significant bit) and inserts the sign bit at the most-significant bit. The contents of <i>src2</i> (or the immediate value) specify the amount to shift. If <i>src2</i> (or the immediate value) is greater than 63, <i>src1</i> shifts by <i>src2</i> MOD 64.
Doubleword Shift Right Logical (DSRL)	Shifts the contents of a 64-bit register right (towards the least-significant bit) and inserts zeros at the most-significant bit. The contents of <i>src1</i> specify the value to shift, and the contents of <i>src2</i> (or the immediate value) specify the amount to shift. If <i>src2</i> (or the immediate value) is greater than 63, <i>src1</i> shifts by <i>src2</i> MOD 64.
Doubleword Subtract with Overflow (DSUB)	Computes the twos-complement difference for two signed 64-bit values. This instruction subtracts the contents of <i>src2</i> from the contents of <i>src1</i> , or it can subtract the immediate value from the contents of <i>src1</i> . It puts the result in the destination register. When the true result's sign differs from the destination register's sign, the system signals an overflow exception.
Doubleword Subtract without Overflow (DSUBU)	Computes the twos complement difference for two unsigned 64-bit values. This instruction subtracts the contents of <i>src2</i> from the contents of <i>src1</i> , or it can subtract the immediate value from the contents of <i>src1</i> . It puts the result in the destination register. Overflow exceptions never happen.

5.6 Jump and Branch Instructions

The jump and branch instructions let you change an assembly program's control flow. This section of the book describes jump and branch instructions.

5.6.1 Jump and Branch Instructions

Jump and branch instructions change the flow of a program. Table 20, page 47, summarizes the formats of jump and branch instructions.

Table 20. Jump and Branch Format Summary

Description	Op-Code	Operand
Jump	J	<i>address</i>
Jump and Link	JAL	<i>address target return,target</i>
Branch on Equal	BEQ	<i>src1,src2,label</i>
Branch on Greater	BGT	<i>src1,immediate,label</i>
Branch on Greater/Equal	BGE	
Branch on Greater/Equal Unsigned	BGEU	
Branch on Greater Than Unsigned	BGTU	
Branch on Less Than	BLT	
Branch on Less/Equal	BLE	
Branch on Less/Equal Unsigned	BLEU	
Branch on Less Than Unsigned	BLTU	
Branch on Not Equal	BNE	
Branch	B	<i>label</i>
Branch and Link	BAL	
Branch on Equal Likely*	BEQL	<i>src1,src2,label</i>
Branch on Greater Than Likely*	BGTL	<i>src1, immediate,label</i>
Branch on Greater/Equal Likely*	BGEL	
Branch on Greater/Equal Unsigned Likely*	BGEUL	
Branch on Greater Than Unsigned Likely*	BGTUL	
Branch on Less Than Likely*	BLTL	
Branch on Less/Equal Likely*	BLEL	
Branch on Less/Equal Unsigned Likely*	BLEUL	
Branch on Less Than Unsigned Likely*	BLTUL	
Branch on Not Equal Likely*	BNEL	
Branch on Equal to Zero	BEQZ	<i>src1,label</i>
Branch on Greater/Equal Zero	BGEZ	
Branch on Greater Than Zero	BGTZ	

Description	Op-Code	Operand
Branch on Greater or Equal to Zero and Link	BGEZAL	
Branch on Less Than Zero and Link	BLTZAL	
Branch on Less/Equal Zero	BLEZ	
Branch on Less Than Zero	BLTZ	
Branch on Not Equal to Zero	BNEZ	
Branch on Equal to Zero Likely*	BEQZL	<i>src1,label</i>
Branch on Greater/Equal Zero Likely*	BGEZL	
Branch on Greater Than Zero Likely*	BGTZL	
Branch on Greater or Equal to Zero and Link Likely*	BGEZALL	
Branch on Less Than Zero and Link Likely*	BLTZALL	
Branch on Less/Equal Zero Likely*	BLEZL	
Branch on Less Than Zero Likely*	BLTZL	
Branch on Not Equal to Zero Likely*	BNEZL	

* not valid on MIPS1 architecture

5.6.2 Jump and Branch Instruction Descriptions

In Table 21, the branch instructions, branch destinations must be defined in the source being assembled.

Table 21. Jump and Branch Instruction Descriptions

Instruction Name	Description
Branch (B)	Branches unconditionally to the specified label.
Branch and Link (BAL)	Branches unconditionally to the specified label and puts the return address in general register \$31.
Branch on Equal (BEQ)	Branches to the specified label when the contents of <i>src1</i> equal the contents of <i>src2</i> , or when the contents of <i>src1</i> equal the immediate value.
Branch on Equal to Zero (BEQZ)	Branches to the specified label when the contents of <i>src1</i> equal zero.

Instruction Name	Description
Branch on Greater Than (BGT)	Branches to the specified label when the contents of <i>src1</i> are greater than the contents of <i>src2</i> , or it can branch when the contents of <i>src1</i> are greater than the immediate value. The comparison treats the comparands as signed 32-bit values.
Branch on Greater/Equal Unsigned (BGEU)	Branches to the specified label when the contents of <i>src1</i> are greater than or equal to the contents of <i>src2</i> , or it can branch when the contents of <i>src1</i> are greater than or equal to the immediate value. The comparison treats the comparands as unsigned 32-bit values.
Branch on Greater/Equal Zero (BGEZ)	Branches to the specified label when the contents of <i>src1</i> are greater than or equal to zero.
Branch on Greater/Equal Zero and Link (BGEZAL)	Branches to the specified label when the contents of <i>src1</i> are greater than or equal to zero and puts the return address in general register \$31. When this write is done, it destroys the contents of the register. See the MIPS Microprocessor User's Manual appropriate to your architecture for more information. Do not use BGEZAL \$31.
Branch on Greater or Equal (BGE)	Branches to the specified label when the contents of <i>src1</i> are greater than or equal to the contents of <i>src2</i> , or it can branch when the contents of <i>src1</i> are greater than or equal to the immediate value. The comparison treats the comparands as signed 32-bit values.
Branch on Greater Than Unsigned (BGTU)	Branches to the specified label when the contents of <i>src1</i> are greater than the contents of <i>src2</i> , or it can branch when the contents of <i>src1</i> are greater than the immediate value. The comparison treats the comparands as unsigned 32-bit values.
Branch on Greater Than Zero (BGTZ)	Branches to the specified label when the contents of <i>src1</i> are greater than zero.
Branch on Less Than Zero (BLTZ)	Branches to the specified label when the contents of <i>src1</i> are less than zero. The program must define the destination.
Branch on Less Than (BLT)	Branches to the specified label when the contents of <i>src1</i> are less than the contents of <i>src2</i> , or it can branch when the contents of <i>src1</i> are less than the immediate value. The comparison treats the comparands as signed 32-bit values.
Branch on Less/Equal Unsigned (BLEU)	Branches to the specified label when the contents of <i>src1</i> are less than or equal to the contents of <i>src2</i> , or it can branch when the contents of <i>src1</i> are less than or equal to the immediate value. The comparison treats the comparands as unsigned 32-bit values.

Instruction Name	Description
Branch on Less/Equal Zero (BLEZ)	Branches to the specified label when the contents of <i>src1</i> are less than or equal to zero. The program must define the destination.
Branch on Less or Equal (BLE)	Branches to the specified label when the contents of <i>src1</i> are less than or equal to the contents of <i>src2</i> , or it can branch when the contents of <i>src1</i> are less than or equal to the immediate value. The comparison treats the comparands as signed 32-bit values.
Branch on Less Than Unsigned (BLTU)	Branches to the specified label when the contents of <i>src1</i> are less than the contents of <i>src2</i> , or it can branch when the contents of <i>src1</i> are less than the immediate value. The comparison treats the comparands as unsigned 32-bit values.
Branch on Less Than Zero and Link (BLTZAL)	Branches to the specified label when the contents of <i>src1</i> are less than zero and puts the return address in general register \$31. Because the value is always stored in register 31, there is a chance of a stored value being overwritten before it is used. See the MIPS microprocessor user's manual appropriate to your architecture for more information. Do not use BGEZAL \$31
Branch on Not Equal (BNE)	Branches to the specified label when the contents of <i>src1</i> do not equal the contents of <i>src2</i> , or it can branch when the contents of <i>src1</i> do not equal the immediate value.
Branch on Not Equal to Zero (BNEZ)	Branches to the specified label when the contents of <i>src1</i> do not equal zero.
Jump (J)	Unconditionally jumps to a specified location. A symbolic address or a general register specifies the destination. The instruction <code>J \$31</code> returns from a JAL call instruction.
Jump And Link (JAL)	Unconditionally jumps to a specified location and puts the return address in a general register. A symbolic address or a general register specifies the target location. By default, the return address is placed in register \$31. If you specify a pair of registers, the first receives the return address and the second specifies the target. The instruction <code>JAL procname</code> transfers to <code>procname</code> and saves the return address. For the two-register form of the instruction, the target register may not be the same as the return-address register. For the one-register form, the target may not be \$31.
Branch Likely Instructions	Same as the ordinary branch instruction (without the "Likely"), except in a branch likely instruction, the instruction in the delay slot is nullified if the conditional branch is not taken. Note: The branch likely instructions should be used only inside a <code>.set noreorder</code> schedule in an assembly program. The assembler does not attempt to schedule the delay slot of a branch likely instruction.

5.7 Special Instructions

The main processor's special instructions do miscellaneous tasks. See Table 22.

5.7.1 Special Instruction Descriptions

Table 22. Special Instruction Descriptions

Instruction Name	Description
Break (BREAK)	Unconditionally transfers control to the exception handler. The <i>breakcode</i> operand is interpreted by software conventions. The <i>breakcode1</i> operand is used to fill the low-order 10 bits of the 20-bit immediate field in the BREAK instruction. The optional second operand, <i>breakcode2</i> , fills the high-order 10 bits.
Exception Return (ERET)	Returns from an interrupt, exception or error trap. Similar to a branch or jump instruction, ERET executes the next instruction before taking effect. Use this on R4000 processor machines in place of RFE.
Move From HI Register (MFHI)	Moves the contents of the HI register to a general-purpose register.
Move From LO Register (MFLO)	Moves the contents of the LO register to a general-purpose register.
Move To HI Register (MTHI)	Moves the contents of a general-purpose register to the HI register.
Move To LO Register (MTLO)	Moves the contents of a general-purpose register to the LO register.
Restore From Exception (RFE)	Restores the previous interrupt called and user/kernel state. This instruction can execute only in kernel state and is unavailable in user mode.
Syscall (SYSCALL)	Causes a system call trap. The operating system interprets the information set in registers to determine what system call to do.

5.8 Coprocessor Interface Instructions

The coprocessor interface instructions provide standard ways to access your machine's coprocessors. See Table 9 and Table 24, page 54.

5.8.1 Coprocessor Interface Summary

Table 23. Coprocessor Interface Formats

Description	Op-code	Operand
Load Word Coprocessor <i>z</i>	LWCz	<i>dest-copr, address</i>
Load Double Coprocessor <i>z</i> *	LDCz	
Store Word Coprocessor <i>z</i>	SWCz	<i>src-copr, address</i>
Store Double Coprocessor <i>z</i> *	SDCz	
Move From Coprocessor <i>z</i>	MFCz	<i>dest-gpr, source</i>
Move To Coprocessor <i>z</i>	MTCz	<i>src-gpr, destination</i>
Doubleword Move From Coprocessor <i>z</i> **	DMFCz	
Doubleword Move To Coprocessor <i>z</i> **	DMTCz	
Branch Coprocessor <i>z</i> False	BCzF	<i>label</i>
Branch Coprocessor <i>z</i> True	BCzT	
Branch Coprocessor <i>z</i> False Likely*	BCzFL	
Branch Coprocessor <i>z</i> True Likely*	BCzTL	
Coprocessor <i>z</i> Operation	Cz	<i>expression</i>
Control From Coprocessor <i>z</i>	CFCz	<i>dest-gpr, source</i>
Control To Coprocessor <i>z</i>	CTCz	<i>src-gpr, destination</i>

* not valid on MIPS1 architecture
** not valid on MIPS1 and MIPS2 architectures

Note: You cannot use coprocessor load and store instructions with the system control coprocessor (cp0).

5.8.2 Coprocessor Interface Instruction Descriptions

Table 24. Coprocessor Interface Instruction Descriptions

Instruction Name	Description
Branch Coprocessor z True (BCzT)	Branches to the specified label when the specified coprocessor asserts a true condition. The z selects one of the coprocessors. A previous coprocessor operation sets the condition.
Branch Coprocessor z False (BCzF)	Branches to the specified label when the specified coprocessor asserts a false condition. The z selects one of the coprocessors. A previous coprocessor operation sets the condition.
Branch Coprocessor z True Likely (BCzTL)	Branches to the specified label when the specified coprocessor asserts a true condition. If the conditional branch is not taken, the instruction in the branch delay slot is nullified. Note: The branch likely instructions should be used only within a <code>.set noreorder</code> block. The assembler does not attempt to schedule the delay slot of a branch likely instruction.
Branch Coprocessor z False Likely (BCzFL)	Branches to the specified label when the specified coprocessor asserts a false condition. If the conditional branch is not taken, the instruction in the branch delay slot is nullified. Note: The branch likely instructions should be used only within a <code>.set noreorder</code> block. The assembler does not attempt to schedule the delay slot of a branch likely instruction.
Control From Coprocessor z (CFCz)	Stores the contents of the coprocessor control register specified by the source in the general register specified by <i>dest-gpr</i> .
Control To Coprocessor (CTCz)	Stores the contents of the general register specified by <i>src-gpr</i> in the coprocessor control register specified by the destination.
Coprocessor z Operation (Cz)	Executes a coprocessor-specific operation on the specified coprocessor. The z selects one of four distinct coprocessors.
Load Word Coprocessor z (LWCz)	Loads the destination with the contents of a word that is at the memory location specified by the effective address. The z selects one of four distinct coprocessors. Load Word Coprocessor replaces all register bytes with the contents of the loaded word. If bits 0 and 1 of the effective address are not zero, the machine signals an address exception.

Instruction Name	Description
Load Double Coprocessor z (LDCz)	Loads a doubleword from the memory location specified by the effective address and makes the data available to coprocessor unit z. The manner in which each coprocessor uses the data is defined by the individual coprocessor specifications. This instruction is not valid in MIPS1 architectures. If any of the three least-significant bits of the effective address are non-zero, the machine signals an address error exception.
Move From Coprocessor z (MFCz)	Stores the contents of the coprocessor register specified by the source in the general register specified by <i>dest-gpr</i> .
Move To Coprocessor z (MTCz)	Stores the contents of the general register specified by <i>src-gpr</i> in the coprocessor register specified by the <i>destination</i> .
Doubleword Move From Coprocessor z (DMFCz)	Stores the 64-bit contents of the coprocessor register specified by the source into the general register specified by <i>dest-gpr</i> .
Doubleword Move To Coprocessor z (DMTCz)	Stores the 64-bit contents of the general register <i>src-gpr</i> into the coprocessor register specified by the <i>destination</i> .
Store Word Coprocessor z (SWCz)	Stores the contents of the coprocessor register in the memory location specified by the effective address. The z selects one of four distinct coprocessors. If bits 0 and 1 of the effective address are not zero, the machine signals an address error exception.
Store Double Coprocessor z (SDCz)	Coprocessor z sources a doubleword, which the processor writes the memory location specified by the effective address. The data to be stored is defined by the individual coprocessor specifications. This instruction is not valid in MIPS1 architecture. If any of the three least-significant bits of the effective address are non-zero, the machine signals an address error exception.

Coprocessor Instruction Set [6]

This chapter describes the coprocessor instructions for these coprocessors:

- System control coprocessor (cp0) instructions
- Floating-point coprocessor instructions

See Chapter 5, page 25, for a description of the main processor's instructions and the coprocessor interface instructions.

6.1 Instruction Notation

The tables in this chapter list the assembler format for each coprocessor's load, store, computational, jump, branch, and special instructions. The format consists of an op-code and a list of operand formats. The tables list groups of closely related instructions; for those instructions, you can use any op-code with any specified operand.

Note: The system control coprocessor instructions do not have operands.

Operands can have any of these formats:

- Memory references: for example, a relocatable symbol +/- an expression(register)
- Expressions (for immediate values)
- Two or three operands: for example, ADD \$3,\$4 is the same as ADD \$3,\$3,\$4

The following terms are used to discuss floating-point operations:

- infinite: A value of +1 or -1.
- infinity: A symbolic entity that represents values with magnitudes greater than the largest value in that format.
- ordered: The usual result from a comparison, namely: <,=, or >.
- NaN: Symbolic entities that represent values not otherwise available in floating-point formats. There are two kinds of NaNs. *Quiet NaNs* represent unknown or uninitialized values. *Signaling NaNs* represent symbolic values and values that are too big or too precise for the format. Signaling NaNs raise an invalid operation exception whenever an operation is attempted on them.

- unordered: The condition that results from a floating-point comparison when one or both operands are NaNs.

6.2 Floating-Point Instructions

The floating-point coprocessor has these classes of instructions:

- Load and Store Instructions: Load values and move data between memory and coprocessor registers.
- Move Instructions: Move data between registers.
- Computational Instructions: Do arithmetic and logical operations on values in coprocessor registers.
- Relational Instructions: Compare two floating-point values.

A particular floating-point instruction may be implemented in hardware, software, or a combination of hardware and software.

6.2.1 Floating-Point Formats

The formats for the single- and double-precision floating-point constants are shown in Figure 2, page 58:

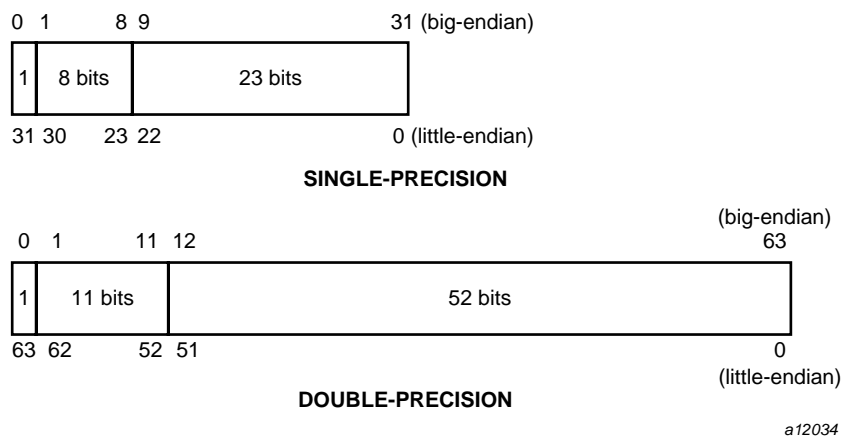

Figure 2. Floating Point Formats

6.2.2 Floating-Point Load and Store Formats

Floating-point load and store instructions must use even registers. The operands in the following tables have the following meanings:

<u>Operand</u>	<u>Meaning</u>
<i>address</i>	Offset (base)
<i>destination</i>	Destination register
<i>source</i>	Source register

Table 25. Floating-Point Load and Store Formats

Description	Op-Code	Operand
Load Fp		
Double	L.D	<i>destination, address</i>
Single	L.S	
Load Indexed Fp		
Double	LDXC1	<i>destination, index(base)</i>
Single	LWXC1	
Load Immediate Fp		
Double	LI.D	<i>destination, floating-point constant</i>
Single	LI.S	
Store Fp		
Double	S.D	<i>source, address</i>
Single	S.S	
Store Indexed Fp		
Double	SDXC1	<i>destination, index(base)</i>
Single	SWXC1	

6.2.3 Floating-Point Load and Store Descriptions

This section groups the instructions by function. See Section 6.2, page 58, for the op-codes. Table 26, page 60, describes the floating-point Load and Store instructions.

Table 26. Floating-Point Load and Store Descriptions

Instruction	Description
Load Fp Instructions	Load eight bytes for double-precision and four bytes for single-precision from the specified effective address into the destination register, which must be an even register (32-bit only) . The bytes must be word aligned. Note: It is recommended that you use doubleword alignment for double-precision operands. It is required in the MIPS2 architecture (R4000 and later).
Load Indexed Fp Instructions	Indexed loads follow the same description as the load instructions above except that indexed loads use <i>index+base</i> to specify the effective address (64-bit only).
Store Fp Instructions	Stores eight bytes for double-precision and four bytes for single-precision from the source floating-point register in the destination register, which must be an even register (32-bit only). Note: It is recommended that you use doubleword alignment for double-precision operands. It is required in the MIPS2 architecture and later.
Store Indexed Fp Instructions	Indexed stores follow the same description as the store instructions above except that indexed stores use <i>index+base</i> to specify the effective address (64-bit only).

6.2.4 Floating-Point Computational Formats

This part of Chapter 6 describes floating-point computational instructions. The operands in Table 29, page 66 and Table 31, page 70 have the following meaning:

<u>Operand</u>	<u>Meaning</u>
<i>destination</i>	Destination register
<i>gpr</i>	General-purpose register

source

Source register

Table 27. Floating-Point Computational Instructions

Description	Op-code	Operand
Absolute Value Fp		
Double	ABS.D	<i>destination, src1</i>
Single	ABS.S	
Negate Fp		
Double	NEG.D	
Single	NEG.S	
Add Fp		
Double	ADD.D	<i>destination, src1, src2</i>
Single	ADD.S	
Divide Fp		
Double	DIV.D	
Single	DIV.S	
Multiply Fp		
Double	MUL.D	
Single	MUL.S	
Subtract Fp		
Double	SUB.D	
Single	SUB.S	
Multiply Add FP		
Double	MADD.D	<i>destination, src1, src2, src3</i>
Single	MADD.S	
Negative Multiply Add FP		
Double	NMADD.D	
Single	NMADD.S	

Description	Op-code	Operand
Multiply Subtract FP		
Double	MSUB.D	
Single	MSUB.S	
Negative Multiply Subtract FP		
Double	NMSUB.D	
Single	NMSUB.S	
Convert Source to Specified Fp Precision		
Double to Single Fp	CVT.S.D	<i>destination, src1</i>
Fixed Point to Single Fp	CVT.S.W	
Single to Double Fp	CVT.D.S	
Fixed Point to Double Fp	CVT.D.W	
Single to Fixed Point Fp	CVT.W.S	
Double to Fixed Point Fp	CVT.W.D	
Truncate and Round Operations		
Truncate to Single Fp	TRUNC.W.S	<i>destination, src, gpr</i>
Truncate to Double Fp	TRUNC.W.D	
Round to Single Fp	ROUND.W.S	
Round to Double Fp	ROUND.W.D	
Ceiling to Double Fp	CEIL.W.D	
Ceiling to Single Fp	CEIL.W.S	
Ceiling to Double Fp, Unsigned	CEILU.W.D	
Ceiling to Single Fp, Unsigned	CEILU.W.S	
Floor to Double Fp	FLOOR.W.D	
Floor to Single Fp	FLOOR.W.S	
Floor to Double F, Unsigned	FLOORU.W.D	
Floor to Single Fp Unsigned	FLOORU.W.S	
Round to Double Fp Unsigned	ROUNDU.W.D	
Round to Single Fp Unsigned	ROUNDU.W.S	

Description	Op-code	Operand
Truncate to Double Fp Unsigned	TRUNCU.W.D	
Truncate to Single Fp Unsigned	TRUNCU.W.S	
Convert Source to Specified Fp Precision		
Long Fixed Point to Single Fp	CVT.S.L	<i>destination, src1</i>
Long Fixed Point to Double FP	CVT.D.L	
Single to Long Fixed Point FP	CVT.L.S	
Double to Long Fixed Point FP	CVT.L.D	
Truncate and Round Operations		
Truncate Single to Long Fixed Point	TRUNC.L.S	<i>destination, src, gpr</i>
Truncate Double to Long Fixed Point	TRUNC.L.D	
Round Single to Long Fixed Point	ROUND.L.S	
Round Double to Long Fixed Point	ROUND.L.D	
Ceiling Single to Long Fixed Point	CEIL.L.S	
Ceiling Double to Long Fixed Point	CEIL.L.D	
Floor Single to Long Fixed Point	FLOOR.L.S	
Floor Double to Long Fixed Point	FLOOR.L.D	
Reciprocal Approximation Operations		
Reciprocal Approximation Single Fp	RECIPS	<i>destination, src1</i>
Reciprocal Approximation Double Fp	RECIP.D	

Description	Op-code	Operand
Reciprocal Square Root Single Fp	RSQRT.S	
Reciprocal Square Root Double Fp	RSQRT.D	

6.2.5 Floating-Point Computational Instruction Descriptions

This section groups the instructions by function. Refer to Table 29, page 66, and Table 31, page 70, for the op-code names. Table 28 describes the floating-point computational instructions.

Table 28. Floating-Point Computational Instruction Descriptions

Instruction	Description
Absolute Value Fp Instructions	Compute the absolute value of the contents of <i>src1</i> and put the specified precision floating-point result in the destination register.
Add Fp Instructions	Add the contents of <i>src1</i> (or the destination) to the contents of <i>src2</i> and put the result in the destination register. When the sum of two operands with opposite signs is exactly zero, the sum has a positive sign for all rounding modes except round toward -1 . For that rounding mode, the sum has a negative sign.
Convert Source to Another Precision Fp Instructions	Convert the contents of <i>src1</i> to the specified precision, round according to the rounding mode, and put the result in the destination register.
Multiply-Then-Add Fp Instructions	Multiply the contents of <i>src2</i> and <i>src3</i> , then add the result to <i>src1</i> and store in the destination register (MADD). The NMADD instruction does the same multiply then add, but then negates the sign of the result (64-bit only).
Multiply-Then-Subtract Fp Instructions	Multiply the contents of <i>src2</i> and <i>src3</i> , then subtract the result from <i>src1</i> and store in the destination register (MSUB). The NMSUB instruction does the same multiply then subtract, but then negates the sign of the result (64-bit only).

Instruction	Description
Truncate and Round instructions	The TRUNC instructions truncate the value in the source floating-point register and put the resulting integer in the destination floating-point register, using the third (general-purpose) register to hold a temporary value. (This is a macro-instruction.) The ROUND instructions work like TRUNC, but round the floating-point value to an integer instead of truncating it.
Divide Fp Instructions	Compute the quotient of two values. These instructions treat <i>src1</i> as the dividend and <i>src2</i> as the divisor. Divide Fp instructions divide the contents of <i>src1</i> by the contents of <i>src2</i> and put the result in the destination register. If the divisor is a zero, the machine signals a error if the divide-by-zero exception is enabled.
Multiply Fp Instructions	Multiplies the contents of <i>src1</i> (or the destination) with the contents of <i>src2</i> and puts the result in the destination register.
Negate FP Instructions	Compute the negative value of the contents of <i>src1</i> and put the specified precision floating-point result in the destination register.
Subtract Fp Instructions	Subtract the contents of <i>src2</i> from the contents of <i>src1</i> (or the destination). These instructions put the result in the destination register. When the difference of two operands with the same signs is exactly zero, the difference has a positive sign for all rounding modes except round toward -1 . For that rounding mode, the sum has a negative sign.
Reciprocal Approximation Instructions	For RECIP, the reciprocal of the value in <i>src1</i> is approximated and placed into the destination register. For RSQRT the reciprocal of the square root of the value in <i>src1</i> is approximated and placed into the destination register.

6.2.6 Floating-Point Relational Operations

Table 29 summarizes the floating-point relational instructions. The first column under Condition gives a mnemonic for the condition tested. As the “branch on true/false” condition can be used logically to negate any condition, the second column supplies a mnemonic for the logical negation of the condition in the first column. This provides a total of 32 possible conditions. The four columns under Relations give the result of the comparison based on each condition. The final column states if an invalid operation is signaled for each condition.

For example, with an equal condition (EQ mnemonic in the True column), the logical negation of the condition is not equal (NEQ), and a comparison that is

equal is True for equal and False for greater than, less than, and unordered, and no Invalid Operation Exception is given if the relation is unordered.

Table 29. Floating-Point Relational Operators

Conditions: Mnemonics True	Conditions: Mnemonics False	Relations: Greater Than	Less Than	Equal	Unordered	Invalid Operation Exception if Unordered
F	T	F	F	F	F	no
UN	OR	F	F	F	T	no
EQ	NEQ	F	F	T	F	no
UEQ	OLG	F	F	T	T	no
OLT	UGE	F	T	F	F	no
ULT	OGE	F	T	F	T	no
OLE	UGT	F	T	T	F	no
ULE	OGT	F	T	T	T	no
SF	ST	F	F	F	F	yes
NGLE	GLE	F	F	F	T	yes
SEQ	SNE	F	F	T	F	yes
NGL	GL	F	F	T	T	yes
LT	NLT	F	T	F	F	yes
NGE	GE	F	T	F	T	yes
LE	NLE	F	T	T	F	yes
NGT	GT	F	T	T	T	yes

The mnemonics found in Table 29 have following meanings:

Mnemonic	Meaning	Mnemonic	Meaning
F	False	T	True
UN	Unordered	OR	Ordered

Mnemonic	Meaning	Mnemonic	Meaning
EQ	Equal	NEQ	Not Equal
UEQ	Unordered or Equal	OLG	Ordered or Less than or Greater than
OLT	Ordered Less Than	UGE	Unordered or Greater than or Equal
ULT	Unordered or Less Than	OGE	Ordered Greater than or Equal
OLE	Ordered Less than or Equal	UGT	Unordered or Greater Than
ULE	Unorderd or Less than or Equal	OGT	Ordered Greater Than
SF	Signaling False	ST	Signaling True
NGLE	Not Greater Than or Less Than or Equal	GLE	Greater Than, or Less Than or Equal
SEQ	Signaling Equal	SNE	Signaling Not Equal
NGL	Not Greater Than or Less Than	GL	Greater Than or Less Less Than
LT	Less Than	NLT	Not Less Than
NGE	Not Greater Than	GE	Greater Than or Equal or Equal
LE	Less Than or Equal	NLE	Not Less Than or Equal
NGT	Not Greater Than	GT	Greater Than

To branch on the result of a relational:

```

/* branching on a compare result */

c.eq.s $fcc0,$f1,$f12 /* compare the single-precision values */
bclt $fcc0, true      /* if $f1 equals $f2, branch to true */
bc1f $fcc0, false    /* if $f1 does not equal $f2, branch */
                    /* to false */

```

6.2.7 Floating-Point Relational Instruction Formats

The following are the floating-point relational instruction formats.

Table 30. Floating-Point Relational Instruction Formats

Description	Op-code	Operand
Compare F		
Double	C.FD	<i>src1,src2</i>
Single	C.FS	
Compare UN		
Double	C.UN.D	
Single	C.UN.S	
*Compare EQ		
Double	C.EQ.D	
Single	C.EQ.S	
Compare UEQ		
Double	C.UEQ.D	
Single	C.UEQ.S	
Compare OLT		
Double	C.OLT.D	
Single	C>OLT.S	
Compare ULT		
Double	C.ULT.D	
Single	C.ULT.S	
Compare OLE		
Double	C.OLE.D	
Single	C.OLE.S	
Compare ULE		
Double	C.ULE.D	
Single	C.ULE.S	
Compare SF		
Double	C.SFD	
Single	C.SFS	

Description	Op-code	Operand
Compare NGLE		
Double	C.NGLE.D	<i>src1, src2</i>
Single	C.NGLE.S	
Compare SEQ		
Double	C.SEQ.D	
Single	C.SEQ.S	
Compare NGL		
Double	C.NGL.D	
Single	C.NGL.S	
*Compare LT		
Double	C.LT.D	
Single	C.LT.S	
Compare NGE		
Double	C.NGE.D	
Single	C.NGE.S	
*Compare LE		
Double	C.LE.D	
Single	C.LE.S	
Compare NGT		
Double	C.NGT.D	
Single	C.NGT.S	

Note: These are the most common Compare instructions. The MIPS coprocessor instruction set provides others for IEEE compatibility.

6.2.8 Floating-Point Relational Instruction Descriptions

This section describes the relational instruction descriptions by function. Refer to Chapter 1 for information regarding registers.

Table 31. Floating-Point Relational Instruction Descriptions

Instruction	Description
Compare EQ Instructions	Compare the contents of <i>src1</i> with the contents of <i>src2</i> . If <i>src1</i> equals <i>src2</i> a true condition results; otherwise, a false condition results. The machine does not signal an exception for unordered values.
Compare F Instructions	Compare the contents of <i>src1</i> with the contents of <i>src2</i> . These instructions always produce a false condition. The machine does not signal an exception for unordered values.
Compare LE	Compare the contents of <i>src1</i> with the contents of <i>src2</i> . If <i>src1</i> is less than or equal to <i>src2</i> , a true condition results; otherwise, a false condition results. The machine signals an exception for unordered values.
Compare LT	Compare the contents of <i>src1</i> with the contents of <i>src2</i> . If <i>src1</i> is less than <i>src2</i> , a true condition results; otherwise, a false condition results. The machine signals an exception for unordered values.
Compare NGE	Compare the contents of <i>src1</i> with the contents of <i>src2</i> . If <i>src1</i> is less than <i>src2</i> (or the contents are unordered), a true condition results; otherwise, a false condition results. The machine signals an exception for unordered values.
Compare NGL	Compare the contents of <i>src1</i> with the contents of <i>src2</i> . If <i>src1</i> equals <i>src2</i> or the contents are unordered, a true condition results; otherwise, a false condition results. The machine signals an exception for unordered values.
Compare NGLE	Compare the contents of <i>src1</i> with the contents of <i>src2</i> . If <i>src1</i> is unordered, a true condition results; otherwise, a false condition results. The machine signals an exception for unordered values.
Compare NGT	Compare the contents of <i>src1</i> with the contents of <i>src2</i> . If <i>src1</i> is less than or equal to <i>src2</i> or the contents are unordered, a true condition results; otherwise, a false condition results. The machine signals an exception for unordered values.
Compare OLE Instructions	Compare the contents of <i>src1</i> with the contents of <i>src2</i> . If <i>src1</i> is less than or equal to <i>src2</i> , a true condition results; otherwise, a false condition results. The machine does not signal an exception for unordered values.

Instruction	Description
Compare OLT Instructions	Compare the contents of <i>src1</i> with the contents of <i>src2</i> . If <i>src1</i> is less than <i>src2</i> , a true condition results; otherwise, a false condition results. The machine does not signal an exception for unordered values.
Compare SEQ Instructions	Compare the contents of <i>src1</i> with the contents of <i>src2</i> . If <i>src1</i> equals <i>src2</i> , a true condition results; otherwise, a false condition results. The machine signals an exception for unordered values.
Compare SF Instructions	Compare the contents of <i>src1</i> with the contents of <i>src2</i> . This always produces a false condition. The machine signals an exception for unordered values.
Compare ULE Instructions	Compare the contents of <i>src1</i> with the contents of <i>src2</i> . If <i>src1</i> is less than or equal to <i>src2</i> (or <i>src1</i> is unordered), a true condition results; otherwise, a false condition results. The machine does not signal an exception for unordered values.
Compare UEQ Instructions	Compare the contents of <i>src1</i> with the contents of <i>src2</i> . If <i>src1</i> equals <i>src2</i> (or <i>src1</i> and <i>src2</i> are unordered), a true condition results; otherwise, a false condition results. The machine does not signal an exception for unordered values.
Compare ULT Instructions	Compare the contents of <i>src1</i> with the contents of <i>src2</i> . If <i>src1</i> is less than <i>src2</i> (or the contents are unordered), a true condition results; otherwise, a false condition results. The machine does not signal an exception for unordered values.
Compare UN Instructions	Compare the contents of <i>src1</i> with the contents of <i>src2</i> . If either <i>src1</i> or <i>src2</i> is unordered, a true condition results; otherwise, a false condition results. The machine does not signal an exception for unordered values.

6.2.9 Floating-Point Move Formats

The floating-point **move** instructions move data from source to destination registers (only floating-point registers are allowed).

Description	Op-code	Operand
Move FP		
Single	MOV.S	<i>destination,src1</i>

Description	Op-code	Operand
Double	MOV.D	
Move Conditional on FP False	MOV.F	<i>gpr_dest, gpr_src, cc</i>
Move Conditional on FP True	MOV.T	<i>gpr_dest, gpr_src, cc</i>
Floating-Point Move Conditional on FP False		
Single	MOV.F.S	<i>destination, src1, cc</i>
Double	MOV.F.D	
Floating-Point Move Conditional on FP True		
Single	MOV.T.S	<i>destination, src1, cc</i>
Double	MOV.T.D	
Floating-Point Move Conditional on Not Zero		
Single	MOV.N.S	<i>destination, src1, gpr</i>
Double	MOV.N.D	
Floating-Point Move Conditional on Zero		
Single	MOV.Z.S	<i>gpr_destination, gpr_src1, gpr</i>
Double	MOV.Z.D	

6.2.10 Floating-Point Move Instruction Descriptions

This section describes the floating-point move instructions.

Table 32. Floating-Point Move Instruction Descriptions

Instruction	Description
Move FP Instructions	Move the double or single-precision contents of <i>src1</i> to the destination register, maintaining the specified precision.
Conditional Move Instructions	Move the general-purpose register, <i>src1</i> , to the destination register if the condition code (<i>cc</i>) is zero (MOV.F) or is one (MOV.T).

Instruction	Description
Conditonal FP Move Instructions	Conditionally, move the double-precision or single-precision contents of <i>src1</i> to the destination register, maintaining the specified precision.
Floating-Point Conditonal Move Instructions	Conditionally, move a floating-point value from <i>src1</i> to the destination register if the <i>gpr_register</i> is zero (MOVZ) or not equal to zero (MOVN).

6.3 System Control Coprocessor Instructions

The system control coprocessor (cp0) handles all functions and special and privileged registers for the virtual memory and exception handling subsystems. The system control coprocessor translates addresses from a large virtual address space into the machine's physical memory space. The coprocessor uses a translation lookaside buffer (TLB) to translate virtual addresses to physical addresses.

6.3.1 System Control Coprocessor Instruction Formats

These coprocessor system control instructions do not have operands.

<u>Description</u>	<u>Op-code</u>
Cache (not valid in MIPS1 and MIPS2 architectures)	CACHE
Translation Lookaside Buffer Probe	TLBP
Translation Lookaside Buffer Read	TLBR
Translation Lookaside Buffer Write Random	TLBWR
Translation Lookaside Write Index	TLBWI
Synchronize (Not valid in MIPS1 architectures)	SYNC

6.3.2 System Control Coprocessor Instruction Descriptions

This section describes the system control coprocessor instructions.

Table 33. System Control Coprocessor Instruction Descriptions

Instruction	Description
Cache (CACHE)	Cache is the R4000 instruction to perform cache operations. The 16-bit offset is sign-extended and added to the contents of general register base to form a virtual address. The virtual address is translated to a physical address using the TLB. The 5-bit sub-opcode ("op") specifies the cache operation for that address. Part of the virtual address is used to specify the cache block for the operation. Possible operations include invalidating a cache block, writeback to a secondary cache or memory, etc. Note: This instruction is not valid in MIPS1 or MIPS2 architectures.
Translation Lookaside Buffer Probe (TLBP)	Probes the translation lookaside buffer (TLB) to see if the TLB has an entry that matches the contents of the EntryHi register. If a match occurs, the machine loads the Index register with the number of the entry that matches the EntryHi register. If no TLB entry matches, the machine sets the high-order bit of the Index register.
Translation Lookaside Buffer Read (TLBR)	Loads the EntryHi and EntryLo registers with the contents of the translation lookaside buffer (TLB) entry specified in the TLB Index register.
Translation Lookaside Buffer Write Random (TLBWR)	Loads the specified translation lookaside buffer (TLB) entry with the contents of the EntryHi and EntryLo registers. The contents of the TLB Random register specify the TLB entry to be loaded.
Translation Lookaside Buffer Write Index (TLBWI)	Loads the specified translation lookaside buffer (TLB) entry with the contents of the EntryHI and EntryLO registers. The contents of the TLB Index register specify the TLB entry to be loaded.
Synchronize (SYNC)	Ensures that all loads and stores fetched before the sync are completed, before allowing any following loads or stores. Use of sync to serialize certain memory references may be required in multiprocessor environments. Note: This instruction is not valid in the MIPS1 architecture.

6.3.3 Control and Status Register

Floating-point coprocessor control register 31 contains status and control information. See Figure 3. It controls the arithmetic rounding mode and the enabling of user-level traps, and indicates exceptions that occurred in the most

recently executed instruction, and any exceptions that may have occurred without being trapped:

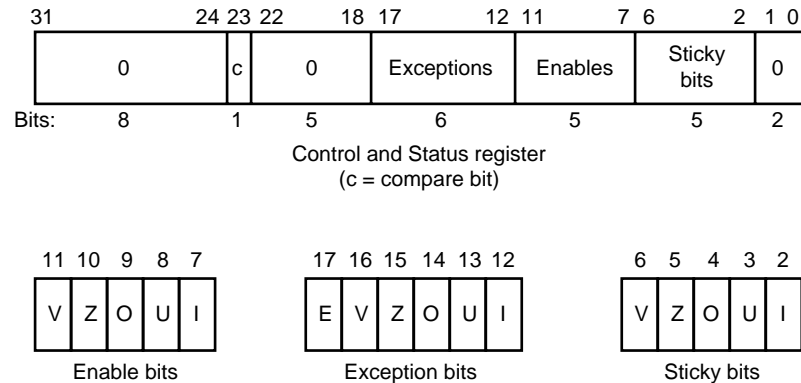

Figure 3. Floating Control and Status Register 31

The exception bits are set for instructions that cause an IEEE standard exception or an optional exception used to emulate some of the more hardware-intensive features of the IEEE standard.

The exception field is loaded as a side-effect of each floating-point operation (excluding loads, stores, and unformatted moves). The exceptions which were caused by the immediately previous floating-point operation can be determined by reading the exception field.

The meaning of each bit in the exception field is given below. If two exceptions occur together on one instruction, the field will contain the inclusive-OR of the bits for each exception:

<u>Exception Field Bit</u>	<u>Description</u>
E	Unimplemented Operation
I	Inexact Exception
O	Overflow Exception
U	Underflow Exception
V	Invalid Operation

Z Division-by-Zero

The unimplemented operation exception is normally invisible to user-level code. It is provided to maintain IEEE compatibility for non-standard implementations.

The five IEEE standard exceptions are listed below:

<u>Field</u>	<u>Description</u>
I	Inexact Exception
O	Overflow Exception
U	Underflow Exception
V	Invalid Operation
Z	Division-by-Zero

Each of the five exceptions is associated with a trap under user control, which is enabled by setting one of the five bits of the enable field, shown above.

When an exception occurs, both the corresponding exception and status bits are set. If the corresponding enable flag bit is set, a trap is taken. In some cases the result of an operation is different if a trap is enabled.

The status flags are never cleared as a side effect of floating-point operations, but may be set or cleared by writing a new value into the status register, using a "move to coprocessor control" instruction.

The floating-point compare instruction places the condition which was detected into the 'c' bit of the control and status register, so that the state of the condition line may be saved and restored. The 'c' bit is set if the condition is true, and cleared if the condition is false, and is affected only by compare and move to control register instructions.

6.3.3.1 Exception Trap Processing

For each IEEE standard exception, a status flag is provided that is set on any occurrence of the corresponding exception condition with no corresponding exception trap signaled. It may be reset by writing a new value into the status register. The flags may be saved and restored individually, or as a group, by software. When no exception trap is signaled, a default action is taken by the floating-point coprocessor, which provides a substitute value for the original, exceptional, result of the floating-point operation. The default action taken depends on the type of exception, and in the case of the Overflow exception, the current rounding mode.

6.3.3.2 Invalid Operation Exception

The invalid operation exception is signaled if one or both of the operands are invalid for an implemented operation. The result, when the exception occurs without a trap, is a quiet NaN when the destination has a floating-point format, and is indeterminate if the result has a fixed-point format. The invalid operations are:

- Addition or subtraction: magnitude subtraction of infinities, such as $(+ \infty) - (- \infty)$.
- Multiplication: 0 times 1, with any signs.
- Division: 0 over 0 or 1 over 1, with any signs.
- Square root of x : where x is less than zero.
- Conversion of a floating-point number to a fixed-point format when an overflow, or operand value of infinity or NaN, precludes a faithful representation in that format.
- Comparison of predicates involving $<$ or $>$ without $?$, when the operands are “unordered”.
- Any operation on a signaling NaN.

Software may simulate this exception for other operations that are invalid for the given source operands. Examples of these operations include IEEE-specified functions implemented in software, such as Remainder: $x \text{ REM } y$, where y is zero or x is infinite; conversion of a floating-point number to a decimal format whose value causes an overflow or is infinity or NaN; and transcendental functions, such as $\ln(-5)$ or $\cos^{-1}(3)$.

6.3.3.3 Division-by-zero Exception

The division by zero exception is signaled on an implemented divide operation if the divisor is zero and the dividend is a finite nonzero number. The result, when no trap occurs, is a correctly signed infinity.

If division by zero traps are enabled, the result register is not modified, and the source registers are preserved.

Software may simulate this exception for other operations that produce a signed infinity, such as $\ln(0)$, $\sec(\pi/2)$, $\csc(0)$ or 0^{-1} .

6.3.3.4 Overflow Exception

The overflow exception is signaled when what would have been the magnitude of the rounded floating-point result, were the exponent range unbounded, is larger than the destination format's largest finite number. The result, when no trap occurs, is determined by the rounding mode and the sign of the intermediate result.

If overflow traps are enabled, the result register is not modified, and the source registers are preserved.

6.3.3.5 Underflow Exception

Two related events contribute to underflow. One is the creation of a tiny non-zero result between $2^{E_{min}}$ (minimum expressible exponent) which, because it is tiny, may cause some other exception later. The other is extraordinary loss of accuracy during the approximation of such tiny numbers by denormalized numbers.

The IEEE standard permits a choice in how these events are detected, but requires that they must be detected the same way for all operations.

The IEEE standard specifies that "tininess" may be detected either: "after rounding" (when a nonzero result computed as though the exponent range were unbounded would lie strictly between $2^{E_{min}}$), or "before rounding" (when a nonzero result computed as though the exponent range and the precision were unbounded would lie strictly between $2^{E_{min}}$). The architecture requires that tininess be detected after rounding.

Loss of accuracy may be detected as either "denormalization loss" (when the delivered result differs from what would have been computed if the exponent range were unbounded), or "inexact result" (when the delivered result differs from what would have been computed if the exponent range and precision were both unbounded). The architecture requires that loss of accuracy be detected as inexact result.

When an underflow trap is not enabled, underflow is signaled (via the underflow flag) only when both tininess and loss of accuracy have been detected. The delivered result might be zero, denormalized, or $2^{E_{min}}$. When an underflow trap is enabled, underflow is signaled when tininess is detected regardless of loss of accuracy.

If underflow traps are enabled, the result register is not modified, and the source registers are preserved.

6.3.3.6 Inexact Exception

If the rounded result of an operation is not exact or if it overflows without an overflow trap, then the inexact exception is signaled. The rounded or overflowed result is delivered to the destination register, when no inexact trap occurs. If inexact exception traps are enabled, the result register is not modified, and the source registers are preserved.

6.3.3.7 Unimplemented Operation Exception

If an operation is specified that the hardware may not perform, due to an implementation restriction on the supported operations or supported formats, an unimplemented operation exception may be signaled, which always causes a trap, for which there are no corresponding enable or flag bits. The trap cannot be disabled.

This exception is raised at the execution of the unimplemented instruction. The instruction may be emulated in software, possibly using implemented floating-point unit instructions to accomplish the emulation. Normal instruction execution may then be restarted.

This exception is also raised when an attempt is made to execute an instruction with an operation code or format code which has been reserved for future architectural definition. The unimplemented instruction trap is not optional, since the current definition contains codes of this kind.

This exception may be signaled when unusual operands or result conditions are detected, for which the implemented hardware cannot handle the condition properly. These may include (but are not limited to), denormalized operands or results, NaN operands, trapped overflow or underflow conditions. The use of this exception for such conditions is optional.

6.3.4 Floating-Point Rounding

Bits 0 and 1 of the coprocessor control register 31 sets the rounding mode for floating-point. The machine allows four rounding modes:

- **Round to nearest** rounds the result to the nearest representable value. When the two nearest representable values are equally near, this mode rounds to the value with the least significant bit zero. To select this mode, set bits 1..0 of control register 31 to 0.

- **Round toward zero** rounds toward zero. It rounds to the value that is closest to and not greater in magnitude than the infinitely precise result. To select this mode, set bits 1..0 of control register 31 to 1.
- **Round toward positive infinity** rounds to the value that is closest to and not less than the infinitely precise result. To select this mode, set bits 1..0 of control register 31 to 2.
- **Round toward negative infinity** rounds toward negative infinity. It rounds to the value that is closest to and not greater than the infinitely precise result. To select this mode, set bits 1..0 of control register 31 to 3.

To set the rounding mode:

```
/* setting the rounding mode */
RoundNearest = 0x0
RoundZero = 0x1
RoundPosInf = 0x2
RoundNegInf = 0x3
    cfcl rt2, $31          # move from coprocessor 1
    and rt, 0xffffffffc   # zero the round mode bits
    or rt, RoundZero      # set mask as round to zero
    ctcl rt, $f31         # move to coprocessor 1
```

Linkage Conventions [7]

This chapter gives rules and examples to follow when designing an assembly language program. The chapter includes a tutorial section that contains information about how calling sequences work. This involves writing a skeleton version of your prospective assembly routine using a high-level language, and then compiling it with the `-S` option to generate a human-readable assembly language file. The assembly language file can then be used as the starting point for coding your routine.

This assembler works in either 32-bit, high performance 32-bit (N32) or 64-bit compilation modes. While these modes are very similar, due to the difference in data, register and address sizes, the N32 and 64-bit assembler linkage conventions are not always the same as those for 32-bit mode. For details on some of these differences, see the *MIPSpro 64-Bit Porting and Transition Guide* and the *MIPSpro N32 ABI Handbook*.

The procedures and examples in this chapter, for the most part, describe 32-bit compilation mode. In some cases, specific differences necessitated by 64-bit mode are highlighted.

7.1 Introduction

When you write assembly language routines, you should follow the same calling conventions that the compilers observe, for two reasons:

- Often your code must interact with compiler-generated code, accepting and returning arguments or accessing shared global data.
- The symbolic debugger gives better assistance in debugging programs using standard calling conventions.

The conventions for the compiler system are a bit more complicated than some, mostly to enhance the speed of each procedure call. Specifically:

- The compilers use the full, general calling sequence only when necessary; where possible, they omit unneeded portions of it. For example, the compilers don't use a register as a frame pointer whenever possible.
- The compilers and debugger observe certain implicit rules rather than communicating via instructions or data at execution time. For example, the debugger looks at information placed in the symbol table by a `".frame"`

directive at compilation time, so that it can tolerate the lack of a register containing a frame pointer at execution time.

7.2 Program Design

This section describes some general areas of concern to the assembly language programmer:

- Stack frame requirements on entering and exiting a routine.
- The “shape” of data (scalars, arrays, records, sets) laid out by the various high-level languages.

For information about register format, and general, special, and floating-point registers, see Chapter 1.

7.2.1 The Stack Frame

This discussion of the stack frame, particularly regarding the graphics, describes 32-bit operations. In 32-bit mode, restrictions such as stack addressing are enforced strictly. While these restrictions are not enforced rigidly for 64-bit stack frame usage, their observance is probably still a good coding practice, especially if you count on reliable debugging information.

The compilers classify each routine into one of the following categories:

- Non-leaf routines, that is, routines that call other procedures.
- Leaf routines, that is, routines that do not themselves execute any procedure calls. Leaf routines are of two types:
 - Leaf routines that require stack storage for local variables
 - Leaf routines that do not require stack storage for local variables.

You must decide the routine category before determining the calling sequence.

To write a program with proper stack frame usage and debugging capabilities, use the following procedure:

1. Regardless of the type of routine, you should include a `.ent` pseudo-op and an entry label for the procedure. The `.ent` pseudo-op is for use by the debugger, and the entry label is the procedure name. The syntax is:

```
.ent    procedure_name
procedure_name:
```

2. If you are writing a leaf procedure that does not use the stack, skip to step 3. For leaf procedure that uses the stack or non-leaf procedures, you must allocate all the stack space that the routine requires. The syntax to adjust the stack size is:

```
subu    $sp,framesize
```

where `framesize` is the size of frame required; `framesize` must be a multiple of 16. Space must be allocated for:

- Local variables.
- Saved general registers. Space should be allocated only for those registers saved. For non-leaf procedures, you must save `$31`, which is used in the calls to other procedures from this routine. If you use registers `$16--$23`, you must also save them.
- Saved floating-point registers. Space should be allocated only for those registers saved. If you use registers `$f20--$f30` (for 32-bit) or `$f24--$f31` (for 64-bit), you must also save them.
- Procedure call argument area. You must allocate the maximum number of bytes for arguments of any procedure that you call from this routine.

Note: Once you have modified `$sp`, you should not modify it again for the rest of the routine.

3. Now include a `.frame` pseudo-op:

```
.frame framereg,framesize,returnreg
```

The virtual frame pointer is a frame pointer as used in other compiler systems but has no register allocated for it. It consists of the *framereg* (`$sp`, in most cases) added to the *framesize* (see step 2 above). The following figures show the stack components for `-32` and `-n32` and `-64`.

The *returnreg* specifies the register containing the return address (usually `$31`). These usual values may change if you use a varying stack pointer or are specifying a kernel trap routine.

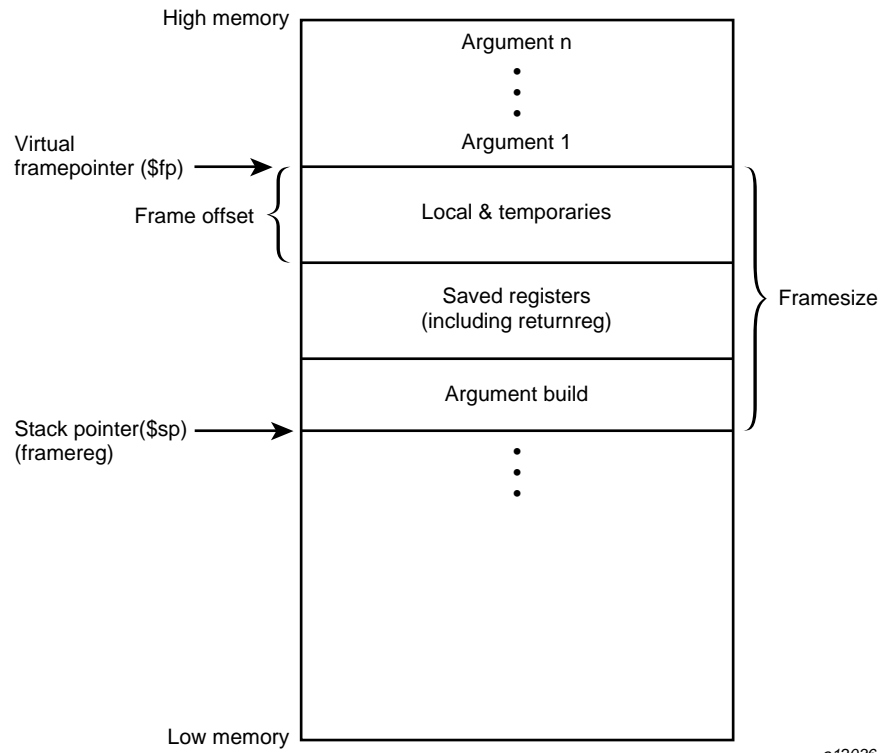
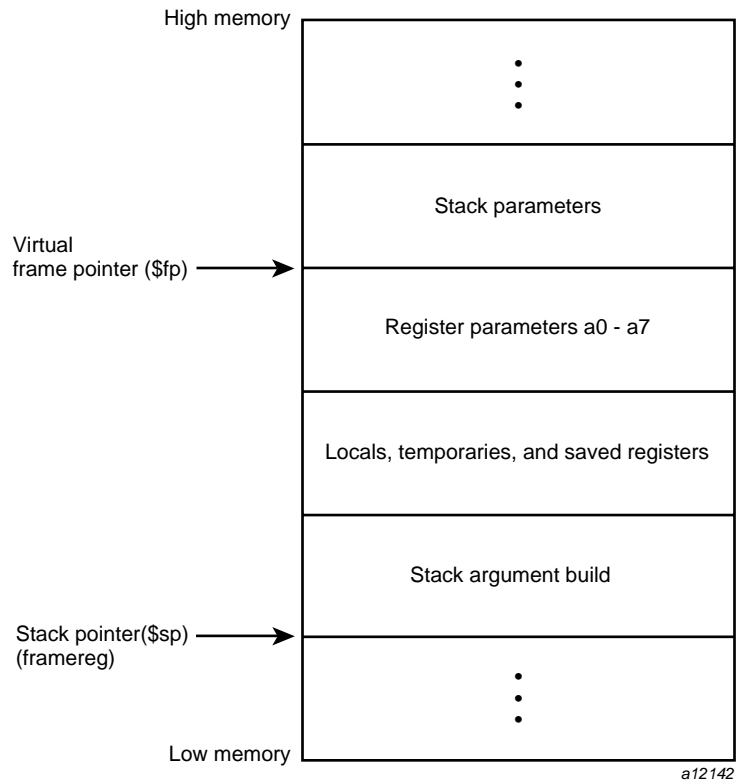

Figure 4. Stack Organization for -32

Figure 5. Stack Organization for `-n32` and `-64`

4. If the procedure is a leaf procedure that does not use the stack, skip to step 7. Otherwise you must save the registers you allocated space for in step 2.

To save the general registers, use the following operations:

```
.mask    bitmask,frameoffset
sw reg,framesize+frameoffset-N($sp)
```

The `.mask` directive specifies the registers to be stored and where they are stored. A bit should be on in `bitmask` for each register saved (for example, if register `§31` is saved, bit 31 should be '1' in `bitmask`. Bits are set in `bitmask` in little-endian order, even if the machine configuration is big-endian). The `frameoffset` is the offset from the virtual frame pointer (this number is usually negative). `N` should be 0 for the highest numbered

register saved and then incremented by four for each subsequently lower numbered register saved. For example:

```
sw    $31, framesize+frameoffset($sp)
sw    $17, framesize+frameoffset-4($sp)
sw    $16, framesize+frameoffset-16($sp)
```

Figure 6, page 87, illustrates this example.

Now save any floating-point registers that you allocated space for in step 2 as follows:

```
.fmask    bitmask, frameoffsets.[sd]
reg, framesize+frameoffset-N($sp)
```

Notice that saving floating-point registers is identical to saving general registers except we use the `.fmask` pseudo-op instead of `.mask`, and the stores are of floating-point singles or doubles. The discussion regarding saving general registers applies here as well, but remember that `N` should be incremented by 16 for doubles. The stack framesize must be a multiple of 16.

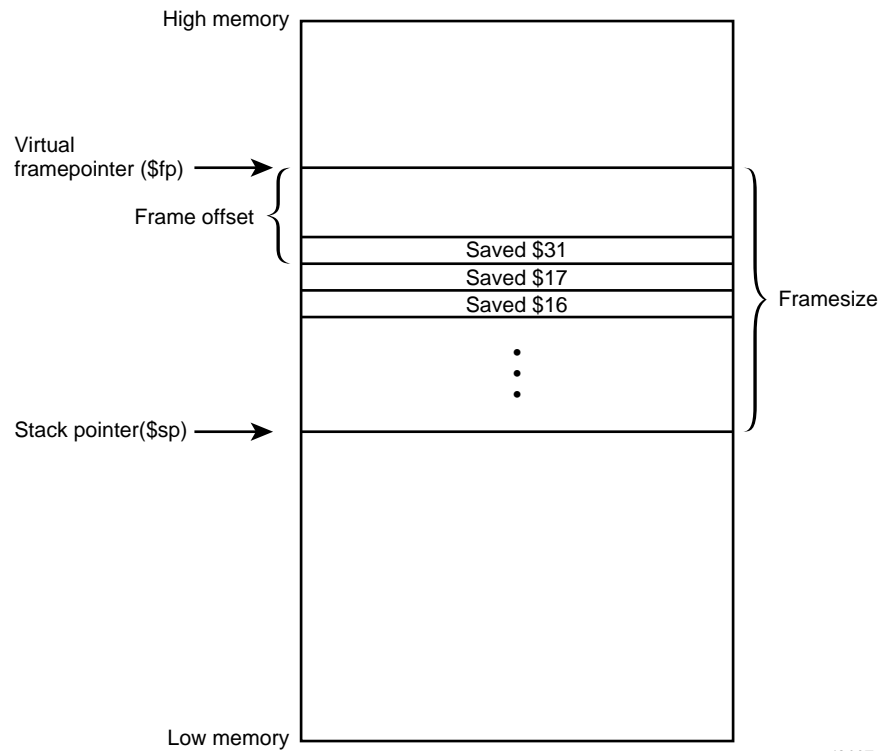

Figure 6. Stack Example

5. This step describes parameter passing: how to access arguments passed into your routine and passing arguments correctly to other procedures. For information on high-level language-specific constructs (call-by-name, call-by-value, string or structure passing), refer to the *MIPSpro Compiling and Performance Tuning Guide*.

As specified in step 2, space must be allocated on the stack for all arguments even though they may be passed in registers. This provides a saving area if their registers are needed for other variables.

General registers must be used for passing arguments. For 32-bit compilations, general registers \$4–\$7 and float registers \$f12, \$f14 are used for passing the first four arguments (if possible). You must allocate a pair of registers (even if it's a single precision argument) that start with an even register for floating-point arguments appearing in registers.

For 64-bit compilations, general registers \$4–\$11 and float registers \$f12, through \$f19 are used for passing the first eight arguments (if possible).

In Table 34 and Table 35, the “fN” arguments are considered single- and double-precision floating-point arguments, and “nN” arguments are everything else. The ellipses (...) mean that the rest of the arguments do not go in registers regardless of their type. The “stack” assignment means that you do not put this argument in a register. The register assignments occur in the order shown in order to satisfy optimizing compiler protocols:

Table 34. Parameter Passing (-32)

Argument List	Register and Stack Assignments
f1, f2	\$f12, \$f14
f1, n1, f2	\$f12, \$6, stack
f1, n1, n2	\$f12, \$6 \$7
n1, n2, n3, n4	\$4, \$5, \$6, \$7
n1, n2, n3, f1	\$4, \$5, \$6, stack
n1, n2, f1	\$4, \$5, (\$6, \$6)
n1, f1	\$4, (\$6, \$7)

Table 35. Parameter Passing (-n32 and -64)

Argument List	Register and Stack Assignments
d1,d2	\$f12, \$f13
s1,s2	\$f12, \$f13
s1,d1	\$f12, \$f13
d1,s1	\$f12, \$f13
n1,d1	\$4,\$f13
d1,n1,d1	\$f12, \$5,\$f14
n1,n2,d1	\$4, \$5,\$f14
d1,n1,n2	\$f12, \$5,\$6

Argument List	Register and Stack Assignments
s1,n1,n2	\$f12, \$5,\$6
d1,s1,s2	\$f12, \$f13, \$f14
s1,s2,d1	\$f12, \$f13, \$f14
n1,n2,n3,n4	\$4,\$5,\$6,\$7
n1,n2,n3,d1	\$4,\$5,\$6,\$f15
n1,n2,n3,s1	\$4,\$5,\$6, \$f15
s1,s2,s3,s4	\$f12, \$f13,\$f14,\$f15
s1,n1,s2,n2	\$f12, \$5,\$f14,\$7
n1,s1,n2,s2	\$4,\$f13,\$6,\$f15
n1,s1,n2,n3	\$4,\$f13,\$6,\$7
d1,d2,d3,d4,d5	\$f12, \$f13, \$f14, \$f15, \$f16
d1,d2,d3,d4,d5,s1,s2,s3,s4	\$f12, \$f13, \$f14, \$f15, \$f16, \$f17, \$f18,\$f19,stack
d1,d2,d3,s1,s2,s3,n1,n2,n3	\$f12, \$f13, \$f14, \$f15, \$f16, \$f17, \$10,\$11, stack

6. Next, you must restore registers that were saved in step 4. To restore general purpose registers:

```
lw reg,framesize+frameoffset-N($sp)
```

To restore the floating-point registers:

```
l.[sd] reg,framesize+frameoffset-N($sp)
```

Refer to step 4 for a discussion of the value of *N*.)

7. Get the return address:

```
lw $31,framesize+frameoffset($sp)
```

8. Clean up the stack:

```
addu framesize
```

9. Return:

```
j $31
```

10. To end the procedure:

```
.end procedurename
```

The difference in stack frame usage for `-n32` and `-64` operations can be summarized as follows:

The portion of the argument structure beyond the initial eight doublewords is passed in memory on the stack, pointed to by the stack pointer at the time of call. The caller does not reserve space for the register arguments; the callee is responsible for reserving it if required (either adjacent to any caller-saved stack arguments if required, or elsewhere as appropriate). No requirement is placed on the callee either to allocate space and save the register parameters, or to save them in any particular place.

7.2.2 The Shape of Data

In most cases, high-level language routine and assembly routines communicate via simple variables: pointers, integers, booleans, and single- and double-precision real numbers. Describing the details of the various high-level data structures (arrays, records, sets, and so on) is beyond the scope of this book. If you need to access such a structure as an argument or as a shared global variable, refer to the *MIPSpro Compiling and Performance Tuning Guide*.

7.3 Examples

This section contains the examples that illustrate program design rules. Each example shows a procedure written in C and its equivalent written in assembly language.

Example 1: Non-leaf procedure

The following example shows a non-leaf procedure. Notice that it creates a stackframe, and also saves its return address since it must put a new return address into register `$31` when it invokes its callee:

```
float
nonleaf(int i, int *j;
{
    double atof();
    int temp;

    temp = i - *j;
```



```

    if (i < *j) temp = -temp;
    return atof(temp);
}
    .globl      nonleaf
#  1  float
#  2  nonleaf(i, j)
#  3  int i, *j;
#  4  {
    .ent      nonleaf 2
nonleaf:
    .cpload $25          ## Load $gp
    subu     $sp, 32     ## Create stackframe
    sw       $31, 20($sp) ## Save the return
                                ## address
    sw       $sp, 24($sp) ## Save gp
    .mask    0x80000000, -4
    .frame   $sp, 32, $31
#  5  double atof();
#  6  int temp;
#  7
#  8  temp = i - *j;
    lw       $2, 0($5)      ## Arguments are in
                                ## $4 and $5
    subu     $3, $4, $2
#  9  if (i < *j) temp = -temp;
    bge     $4, $2, $32     ## Note: $32 is a label,
                                ## not a reg
    negu    $3, $3
$32:
# 10  return atof(temp);
    move     $4, $3
    jal     atof
    cvt.s.  $f0, $f0      ## Return value goes in $f0
    lw      $gp, 24($sp)  ## Restore gp
    lw      $31, 20($sp)  ## Restore return address
    addu    $sp, 32       ## Delete stackframe
    j       $31           ## Return to caller
    .end    nonleaf

```

The `-n32` code for the previous example is shown below. Note that this code is under `.set noreorder`, so be aware of delay slots.

```
.set          noreorder
            # Program Unit: nonleaf
.ent        nonleaf
.globl     nonleaf
nonleaf:    # 0x0
.frame     $sp, 32, $31
.mask     0x80000000, -32
lw $7,0($5)          # load *j
addiu $sp,$sp,-32    #.frame.len.nonleaf
sd $gp,8($sp)        # save $gp
sd $31,0($sp)        # save $ra
lui $31,%hi(%neg(%gp_rel(nonleaf+0))) #load new $gp
addiu $31,$31,%lo(%neg(%gp_rel(nonleaf +0))) #
addu $gp,$25,$31     #
slt $1,$4,$7         # compare i to *j
beq $1,$0,.L.1.1.temp #
subu $7,$4,$7        # i-*j, in delay slot of branch
subu $7,$0,$7        # temp = -temp
.L.1.1.temp:        # 0x2c
lw $25,%call16(atof)($gp)#
jalr $25             #atof
or $4,$7,$0          # delay slot of jalr loads arg
ld $31,0($sp)        # restore $ra
cvt.s.d $f0,$f0     #
ld $tp,8($sp)        # restore $gp
jr $31               #
addiu $sp,$sp,32     # .frame.len.nonleaf
.end nonleaf
```

Example 2: Leaf Procedure

This example shows a leaf procedure that does not require stack space for local variables. Notice that it creates no stackframe, and saves no return address.

```
int
leaf(p1, p2)
    int p1, p2;
    {
        return (p1 > p2) ? p1 : p2;
```

```

    }
    .globl    leaf
#   1      int
#   2      leaf(p1, p2)
#   3      int p1, p2;
#   4      {
    .ent     leaf2
leaf:
    .frame   $sp, 0, $31
#   5      return (p1 > p2) ? p1 : p2;
            ble     $4, $5, $32    ## Arguments in
            ## $4 and $5

            move    $3, $4
            b       $33
$32:
            move    $3, $5
$33:
            move    $2, $3        ## Return value
            ## goes in $2
            j       $31          ## Return to
            ## caller
#   6      }
    .end     leaf

```

The `-n32` code for the previous example looks like this:

```

.set     noreorder
.ent     leaf
.globl   leaf
leaf:    #0x0
        .fram$sp, 0, $31
        slt $2,$5,$4      # compare p1 and p2
        beq $2, $0, .L.1.2.temp #
        or $9,$4,$0      # delay slot
        b .L.1.1.temp     #
        or $2,$9,$0      # delay slot, return p1
.L.1.2.temp: # 0x14
        or $2,$5,$0      # return p2
.L.1.1.temp: # 0x18
        jr $31           #
        nop              # delay slot
        .end     leaf

```

7.4 Writing Assembly Language Code

The rules and parameter requirements that exist between assembly language and other languages are varied and complex. The simplest approach to coding an interface between an assembly routine and a routine written in a high-level language is to do the following:

- Use the high-level language to write a skeletal version of the routine that you plan to code in assembly language.
- Compile the program using the `-S` option, which creates an assembly language (`.s`) version of the compiled source file (the `-O` option, though not required, reduces the amount of code generated, making the listing easier to read).
- Study the assembly-language listing and then, imitating the rules and conventions used by the compiler, write your assembly language code.

Pseudo Op-Codes (Directives) [8]

This chapter describes pseudo op-codes (directives). These pseudo op-codes influence the assembler's later behavior.

8.1 Op-Codes

The assembler has the following pseudo op-codes:

Table 36. Pseudo Op-Codes

<u>Pseudo-Op</u>	<u>Description</u>
<i>.2byte expression1 [, expression2]... [, expressionN]</i>	<p>Truncates the expressions in the comma-separated list to 16-bit values and assembles the values in successive locations. The expressions must be absolute or in the form of a label difference (<i>label1 - label2</i>) if both labels are defined in the same section.</p> <p>This directive optionally can have the form <i>expression1 [: expression2]</i>. The <i>expression2</i> replicates <i>expression1</i>'s value <i>expression2</i> times.</p> <p>This directive does no automatic alignment.</p> <p>(64-bit and N32 only)</p>
<i>.4byte expression1 [, expression2]... [, expressionN]</i>	<p>Truncates the expressions in the comma-separated list to 32-bit values and assembles the values in successive locations.</p> <p>The expressions must be absolute or in the form of a label difference (<i>label1 - label2</i>) if both labels are defined in the same section.</p> <p>This directive optionally can have the form <i>expression1 [: expression2]</i>. The <i>expression2</i> replicates <i>expression1</i>'s value <i>expression2</i> times.</p> <p>This directive does no automatic alignment.</p> <p>(64-bit and N32 only)</p>

`.8byte expression1 [,
expression2]... [,
expressionN]`

Truncates the expressions in the comma-separated list to 64-bit values and assembles the values in successive locations. The expressions must be absolute or in the form of a label difference (*label1* - *label2*) if both labels are defined in the same section.

This directive optionally can have the form `expression1 [: expression2]`. The *expression2* replicates *expression1*'s value *expression2* times. This directive does no automatic alignment.

(64-bit and N32 only)

`.aent name, symno`

Sets an alternate entry point for the current procedure. Use this information when you want to generate information for the debugger. It must appear inside an `.ent/.end` pair.

`.align expression`

Advances the location counter to make the expression low order bits of the counter zero. Normally, the `.half`, `.word`, `.float`, and `.double` directives automatically align their data appropriately. For example, `.word` does an implicit `.align 2` (`.double` does an `.align 3`). You disable the automatic alignment feature with `.align 0`. The assembler reinstates automatic alignment at the next `.text`, `.data`, `.rdata`, or `.sdata` directive.

Labels immediately preceding an automatic or explicit alignment are also realigned. For example, `foo: .align 3; .word 0` is the same as `.align 3; foo: .word 0`.

`.ascii string [,
string]...`

Assembles each string from the list into successive locations. The `.ascii` directive does not null pad the string. You **must** put quotation marks (") around each string. You can use the backslash escape characters. For a list of the backslash characters, see Chapter 4, page 13.

`.asciiz string [,
string]...`

Assembles each string in the list into successive locations and adds a null. You can use the backslash escape characters. For a list of the backslash characters, see Chapter 4, page 13.

<pre>.byte <i>expression1</i> [, <i>expression2</i>]... [, <i>expressionN</i>]</pre>	<p>Truncates the expressions from the comma-separated list to 8-bit values, and assembles the values in successive locations. The expressions must be absolute. The operands can optionally have the form: <i>expression1</i> [: <i>expression2</i>]. The <i>expression2</i> replicates <i>expression1</i>'s value <i>expression2</i> times.</p>
<pre>.comm <i>name</i>, <i>expression</i> [<i>alignment</i>]</pre>	<p>Unless defined elsewhere, <i>name</i> becomes a global common symbol at the head of a block of expression bytes of storage. The linker overlays like-named common blocks, using the maximum of the <i>expressions</i>. The 64-bit and N32 assembler also accepts an optional value which specifies the alignment of the symbol.</p>
<pre>.cpadd <i>reg</i></pre>	<p>Emits code that adds the value of “_gp” to <i>reg</i>.</p>
<pre>.cpload <i>reg</i></pre>	<p>Expands into the three instructions function prologue that sets up the \$gp register. This directive is used by position-independent code.</p>
<pre>.cplocal <i>reg</i></pre>	<p>Causes the assembler to use <i>reg</i> instead of \$gp as the context pointer. This directive is used by position-independent code.</p> <p>(64-bit and N32 only)</p>
<pre>.cprestore <i>offset</i></pre>	<p>Causes the assembler to emit the following at the point where it occurs: <code>sw \$gp, offset (\$sp)</code></p> <p>Also, causes the assembler to generate <code>lw \$gp, offset (\$sp)</code> after every JAL or BAL operation. Offset should point to the saved register area as described in Chapter 7, page 81.</p> <p>This directive is used by position-independent code following the caller-saved gp convention.</p>
<pre>.cpreturn</pre>	<p>Causes the assembler to emit the following at the point where it occurs:</p> <pre>ld \$gp, offset (\$sp)</pre> <p>The <i>offset</i> is obtained from the previous <code>.cpsetup</code> pseudo-op.</p>

<code>.cpsetup <i>reg1</i>, {<i>offset</i> <i>reg2</i>}, <i>label</i></code>	<p>(64-bit and N32 only)</p> <p>Causes the assembler to emit the following at the point where it occurs:</p> <pre>sd \$gp, offset (\$sp) lui \$gp, 0 {label} daddiu \$gp, \$gp, 0 { label } daddu \$gp, \$gp, reg1 ld \$gp, offset (\$sp)</pre> <p>This sequence is used by position-independent code following the callee-saved <code>gp</code> convention. It stores <code>\$gp</code> in the saved register area and calculates the virtual address of <code>label</code> and places it in <code>reg1</code>. By convention, <code>reg1</code> is <code>\$25 (t9)</code>.</p> <p>If <code>reg2</code> is used instead of <code>offset</code>, <code>\$gp</code> is saved and restored to and from this register.</p>
<code>.data</code>	<p>(64-bit and N32 only)</p> <p>Tells the assembler to add all subsequent data to the data section.</p>
<code>.double <i>expression</i> [, <i>expression2</i>] ...[, <i>expressionN</i>]</code>	<p>Initializes memory to 64-bit floating point numbers. The operands optionally can have the form: <code>expression1 [: <i>expression2</i>]</code>. The <code>expression1</code> is the floating point value. The optional <code>expression2</code> is a non-negative expression that specifies a repetition count. The <code>expression2</code> replicates <code>expression1</code>'s value <code>expression2</code> times. This directive aligns its data and any preceding labels automatically to a double-word boundary. You can disable this feature by using <code>.align0</code>.</p>
<code>.dword <i>expression</i> [, <i>expression2</i>] ...[, <i>expressionN</i>]</code>	<p>Truncates the expressions in the comma-separated list to 64-bits and assembles the values in successive locations. The expressions must be absolute. The operands optionally can have the form: <code>expression1 [:<i>expression2</i>]</code>. The <code>expression2</code> replicates <code>expression1</code>'s value <code>expression2</code> number of times. The directive aligns its data and preceding</p>

	labels automatically to a doubleword boundary. You can disable this feature by using <code>.align0</code> .
<code>.dynsym name value</code>	Specifies an ELF <code>st_other</code> value for the object denoted by <i>name</i> (64-bit and N32 only).
<code>.end [proc_name]</code>	Sets the end of a procedure. Use this directive when you want to generate information for the debugger. To set the beginning of a procedure, see <code>.ent</code> .
<code>.endr</code>	Signals the end of a repeat block. To start a repeat block, see <code>.repeat</code> .
<code>.ent proc_name</code>	Sets the beginning of the procedure <i>proc_name</i> . Use this directive when you want to generate information for the debugger. To set the end of a procedure, see <code>.end</code> .
<code>.extern name expression</code>	<i>name</i> is a global undefined symbol whose size is assumed to be <i>expression</i> bytes. The advantage of using this directive, instead of permitting an undefined symbol to become global by default, is that the assembler can decide whether to use the economical <code>\$gp</code> -relative addressing mode, depending on the value of the <code>-G</code> option. As a special case, if <i>expression</i> is zero, the assembler refrains from using <code>\$gp</code> to address this symbol regardless of the size specified by <code>-G</code> .
<code>.file file_number file_name_string</code>	Specifies the source file corresponding to the assembly instructions that follow. For use only by compilers, not by programmers; when the assembler sees this, it refrains from generating line numbers for <code>dbx</code> to use unless it also sees <code>.loc</code> directives.
<code>.float expression1 [, expression2]... [, expressionN]</code>	Initializes memory to single precision 32-bit floating point numbers. The operands optionally can have the form: <i>expression1</i> <_newline>[: <i>expression2</i>]. The optional <i>expression2</i> is a non-negative expression that specifies a repetition count. This optional form replicates <i>expression1</i> 's value <i>expression2</i> times. This directive aligns its data and preceding labels automatically to a

	word boundary. You can disable this feature by using <code>.align0</code> .
<code>.fmask</code> <i>mask offset</i>	Sets a mask with a bit turned on for each floating point register that the current routine saved. The least-significant bit corresponds to register <code>\$f0</code> . The offset is the distance in bytes from the virtual frame pointer at which the floating point registers are saved. The assembler saves higher register numbers closer to the virtual frame pointer. You must use <code>.ent</code> before <code>.fmask</code> and only one <code>.fmask</code> may be used per <code>.ent</code> . Space should be allocated for those registers specified in the <code>.fmask</code> .
<code>.frame</code> <i>frame-register offset return_pc_register</i>	Describes a stack frame. The first register is the frame-register, the offset is the distance from the frame register to the virtual frame pointer, and the second register is the return program counter (or, if the first register is <code>\$0</code> , this directive shows that the return program counter is saved four bytes from the virtual frame pointer). You must use <code>.ent</code> before <code>.frame</code> and only one <code>.frame</code> may be used per <code>.ent</code> . No stack traces can be done in the debugger without <code>.frame</code> .
<code>.globl</code> <i>name</i>	Makes the <i>name</i> external. If the <i>name</i> is defined otherwise (by its appearance as a label), the assembler will export the symbol; otherwise it will import the symbol. In general, the assembler imports undefined symbols (that is, it gives them the UNIX storage class "global undefined" and requires the linker to resolve them).
<code>.gpvalue</code> <i>number</i>	Sets the offset to use in <code>gp_rel</code> relocations; 0 by default. (64-bit and N32 only).
<code>.gpword</code> <i>local-sym</i>	This directive is similar to <code>.word</code> except that the relocation entry for <i>local-sym</i> has the <code>R_MIPS_GPREL32</code> type. After linkage, this results in a 32-bit value that is the distance between <i>local-sym</i> and <code>gp</code> . <i>local-sym</i> must be local. This directive is used by the code generator for PIC switch tables.

<pre><i>.half expression1 [, expression2]... {, expressionN]</i></pre>	<p>Truncates the expressions in the comma-separated list to 16-bit values and assembles the values in successive locations. The <i>expressions</i> must be absolute. This directive optionally can have the form: <i>expression1 [: expression2]</i>. The <i>expression2</i> replicates <i>expression1</i>'s value <i>expression2</i> times. This directive automatically aligns its data appropriately. You can disable this feature by using <i>.align0</i>.</p>
<pre><i>.lab label_name</i></pre>	<p>Associates a named label with the current location in the program text. For use by compilers.</p>
<pre><i>.lcomm name, expression</i></pre>	<p>Makes the <i>name</i>'s data type <i>bss</i>. The assembler allocates the named symbol to the <i>bss</i> area, and the <i>expression</i> defines the named symbol's length. If a <i>.globl</i> directive also specifies the name, the assembler allocates the named symbol to external <i>bss</i>. The assembler puts <i>bss</i> symbols in one of two <i>bss</i> areas. If the defined size is smaller than (or equal to) the size specified by the assembler or compiler's <i>-G</i> command line option, the assembler puts the symbols in the <i>sbss</i> area and uses <i>\$gp</i> to address the data.</p>
<pre><i>.loc file_number line_number [column]</i></pre>	<p>Specifies the source file and the line within that file that corresponds to the assembly instructions that follow. For use by compilers. The assembler ignores the file number when this directive appears in the assembly source file. Then, the assembler assumes that the directive refers to the most recent <i>.file</i> directive. The 64-bit and N32 assembler also supports an optional value that specifies the column number.</p>
<pre><i>.mask mask, offset</i></pre>	<p>Sets a mask with a bit turned on for each general purpose register that the current routine saved. For use by compilers. Bit one corresponds to register <i>\$1</i>. The offset is the distance in bytes from the virtual frame pointer where the registers are saved. The assembler saves higher register numbers closer to the virtual frame pointer. Space should be allocated for those registers appearing in the mask. If bit zero is set it is</p>

	assumed that space is allocated for all 31 registers regardless of whether they appear in the mask.
<code>.nada</code>	Tells the assembler to put in an instruction that has no effect on the machine state. It has the same effect as <code>nop</code> (described below), but it produces more efficient code on an R8000. (64-bit and N32 only)
<code>.nop</code>	Tells the assembler to put in an instruction that has no effect on the machine state. While several instructions cause no-operation, the assembler only considers the ones generated by the <code>nop</code> directive to be wait instructions. This directive puts an explicit delay in the instruction stream. Note: Unless you use <code>.set noreorder</code> , the reorganizer may eliminate unnecessary <code>nop</code> instructions.
<code>.option options</code>	Tells the assembler that certain options were in effect during compilation. (These options can, for example, limit the assembler's freedom to perform branch optimizations.) This <i>option</i> is intended for compiler-generated <code>.s</code> files rather than for hand-coded ones.
<code>.origin expression</code>	Specifies the current offset in a section to the value of <i>expression</i> . (64-bit and N32 only)
<code>.repeat expression</code>	Repeats all instructions or data between the <code>.repeat</code> directive and the <code>.endr</code> directive. The <i>expression</i> defines how many times the data repeats. With the <code>.repeat</code> directive, you cannot use labels, branch instructions, or values that require relocation in the block. To end a <code>.repeat</code> , see <code>.endr</code> .
<code>.rdata</code>	Tells the assembler to add subsequent data into the <code>rdata</code> section.
<code>.sdata</code>	Tells the assembler to add subsequent data to the <code>sdata</code> section.

.section name [,
section type, *section flags*,
section entry size, *section
alignment*]

Instructs the assembler to create a section with the given name and optional attributes.

Legal *section type* values are denoted by variables prefixed by `SHT_` in `<elf.h>`.

Legal *section flags* values are denoted by variables prefixed by `SHF_` in `<elf.h>`.

The *section entry size* specifies the size of each entry in the section. For example, it is 4 for `.text` sections.

The *section alignment* specifies the byte boundary requirement for the section. For example, it is 16 for `.text` sections.

(64-bit and N32 only)

.set option

Instructs the assembler to enable or to disable certain options. Use `.set` options only for hand-crafted assembly routines. The assembler has these default options: `reorder`, `macro`, and `at`. You can specify only one option for each `.set` directive. You can specify these `.set` options:

The `reorder` option lets the assembler reorder machine language instructions to improve performance.

The `noreorder` option prevents the assembler from reordering machine language instructions. If a machine language instruction violates the hardware pipeline constraints, the assembler issues a warning message.

The `macro` option lets the assembler generate multiple machine instructions from a single assembler instruction.

The `nomacro` option causes the assembler to print a warning whenever an assembler operation generates more than one machine language instruction. You must select the `noreorder` option before using the `nomacro` option; otherwise, an error results.

The `at` option lets the assembler use the `$at` register for macros, but generates warnings if the source program uses `$at`. When you use the `noat` option and an assembler operation requires the `$at` register, the assembler issues a warning message; however, the `noat` option does let source programs use `$at` without issuing warnings.

The `nomove` option tells the assembler to mark each subsequent instruction so that it cannot be moved during reorganization. Because the assembler can still insert `nop` instructions where necessary for pipeline constraints, this option is less stringent than `noreorder`. The assembler can still move instructions from below the `nomove` region to fill delay slots above the region or vice versa. The `nomove` option has part of the effect of the “volatile” C declaration; it prevents otherwise independent loads or stores from occurring in a different order than intended.

The `move` option cancels the effect of `nomove`.

The `notransform` option tells the assembler to mark each subsequent instruction so that it cannot be transformed by `pixie(1)` into an equivalent set of instructions. There are restrictions on the use of this option in order to guarantee `pixie`'s ability to still produce code that will execute correctly with the preceding/following transformed code. The sequence of instructions marked `notransform` must behave like a single basic block (i.e., there is only one entry and exit from the sequences and they are the first and last instructions, respectively). If this restriction cannot be met, correct transformed execution can still be guaranteed if the sequence of instructions does not use any of the saved registers `$16..$23`, `$30` (`s0-s8`).

	The transform option cancels the effect of <code>notransform</code> .
<code>.size name, expression</code>	Specifies the size of an object denoted by <i>name</i> to the value of <i>expression</i> .
<code>.space expression</code>	Advances the location counter by the value of the specified <i>expression</i> bytes. The assembler fills the space with zeros.
<code>.struct expression</code>	This permits you to lay out a structure using labels plus directives like <code>.word</code> , <code>.byte</code> , and so forth. It ends at the next segment directive (<code>.data</code> , <code>.text</code> , etc.). It does not emit any code or data, but defines the labels within it to have values which are the sum of <i>expression</i> plus their offsets from the <code>.struct</code> itself.
(symbolic equate)	Takes one of these forms: <code>name = expression</code> or <code>name = register</code> . You must define the name only once in the assembly, and you cannot redefine the name. The expression must be computable when you assemble the program, and the expression must involve operators, constants, and equated symbols. You can use the name as a constant in any later statement.
<code>.text</code>	Tells the assembler to add subsequent code to the text section. (This is the default.)
<code>.type name, value</code>	Specifies the <code>elf</code> type of an object denoted by <i>name</i> to <i>value</i> . Legal <code>elf</code> type values are denoted by variables prefixed by <code>STT_</code> in <code><elf.h></code> . (64-bit and N32 only)
<code>.verstamp major minor</code>	Specifies the major and minor version numbers (for example, version 0.15 would be <code>.verstamp 0 15</code>).
<code>.weakext weak_name [strong_name]</code>	Defines a weak external name and optionally associates it with the <i>strong_name</i> .
<code>.word expression1 [, expression2]... [, expressionN]</code>	Truncates the <i>expressions</i> in the comma-separated list to 32-bits and assembles the values in successive locations. The <i>expressions</i> must be absolute. The operands optionally can have the

form: *expression1* <_newline>[: *expression2*].
The *expression2* replicates *expression1*'s value *expression2* times. This directive aligns its data and preceding labels automatically to a word boundary. You can disable this feature by using `.align0`.

The directives listed below are only accepted in `-o32` compiles; they are only meant for compiler-generated code, and should not be used in hand-written assembly code.

```
.alias  
.asm0  
.bgnb  
.endb  
.err  
.gjaldef  
.gjallive  
.gjrlive  
.liverreg  
.noalias  
.set bopt/nobopt  
.vreg
```

8.2 PIC Assembly Code

By default, the assembler and compilers generate position-independent code (PIC). This is needed for programs that use dynamic shared libraries. For programs assembled with the `-n32` and `-64` options to `as(1)`, see the *MIPSpro 64-Bit Porting and Transition Guide* for further information.

If you want to generate PIC with the assembler using the `-o32` option, assemble with the `-KPIC` and `-G0` options, which are enabled by default.

The following assembler directives support PIC generation: `.option pic2`, `.cpload`, `.cprestore`, `.gpword`, and `.cpadd`. See Section 8.1, page 95 for information about the directives. The following example illustrates the use of these directives with the `-o32` option.

Example 3: KPIC directives example

Consider the following program:

```

        .option   pic2
        .data
        .align   2
$$5:
        .ascii   "hello world\X0A\X00"
        .text
        .align   2
main:
        .set     noreorder
        .cpld    $25
        .set     reorder
        subu    $sp, 40
        sw     $31, 36($sp)
        .cprestore 32
        la     $4, $$5
        jal    printf
        move   $2, $0
        lw     $31, 36($sp)
        addu   $sp, 40
        j      $31

```

The actual instructions generated by the assembler are as follows:

```

        lui    gp,0      #
        addiu   gp,gp,0    #generated by .cpld
        addu   gp,gp,t9 #
        lw     a0,0(gp) # gp-relative addressing used
        lw     t9,0(gp) # t9 is used for func. call
        addiu   sp,sp,-40
        sw     ra,36(sp)
        sw     gp,32(sp) # from .cprestore
        jalr   ra,t9     # jal is changed to jalr
        addiu   a0,a0,0
        lw     ra,36(sp)
        lw     gp,32(sp) # activated by .cprestore
        move   v0,zero
        jr     ra
        addiu   sp,sp,40

```

```
nop
```

The ABI requires that register `t9` (`$25`) be used for indirect function calls, so `.cpload` should always use `$25`; no-reorder mode should also be used. Make sure that `t9` is dead before any function call, because the register is changed (and not restored) during the function call.

If your program uses an indirect jump (`jalr`), you must also use `t9` as the jump register.

If you have an unconditional jump to an external label (`j _cerror`), rewrite it into an indirect jump using `t9`, as in this example:

```
la t9,_cerror
j t9
```

If you use branch-and-link (`bal`) instructions and if the target procedure begins with a `.cpload`, specify an alternate entry point, as in this example:

```
foo: .set noreorder    #callee
     .cpload $25
     .set reorder
$$1: ...              # alternative entry point
     ...
     j $31            # foo returns
bar: ...              # caller
     ...
     bal $$1         # bypass the .cpload
     ...
```

The alternate entry point is important because `.cpload` assumes register `$25` contains the address of `foo`, but in this case, `$25` is not set up. Because both `foo` and `bar` reside in the same file, they must have the same value for `$gp`. The `.cpload` instructions can be and must be bypassed, but because `foo` can still be called from outside, the `.cpload` is still required.

If you don't want to have an alternate entry point, you can set up register `$25` before the `bal`, as in the following:

```
la t9, foo
bal foo
```

Entries of the address table created by `.gpword` are converted into displacement from the context pointer. To get the correct text address, `.cpadd` should be used to add the value of `gp` back to them. The `gp` is updated by the runtime linker, so the correct text address can be reconstructed regardless of the location of the DSO.

A

- address
 - description, 9
 - descriptions, 9
 - format, 8
- addressing, 7
 - alignment, 7
- .aent name, symno, 96
- .align, 96
- aligned data
 - load and store instructions, 8
- alignment
 - addressing, 7
- .ascii, 96
- .asciiz, 96
- assembler
 - tokens, 13

B

- branch instructions
 - filling delay slots, 25
- .byte, 97

C

- .comm, 97
- comments, 14
- computational instructions, 25, 35
 - descriptions - table, , 38
- constants, 14
 - floating-point, 15
 - scalar, 14
 - string, 16
- conventions
 - data types, 21

- expression operators, 21
- expressions, 20
 - lexical, 13
 - linkage, 81
 - precedence, 20
 - statements, 19
- coprocessor instruction
 - notation, 57
- coprocessor instruction set, 57
- coprocessor interface instructions, 52
 - description of, , 54
- counters
 - sections and locations, 17
- .cpadd, 97
- .cpload, 97
- .cplocal, 97
- .cpstore, 97
- .cpreturn, 97
- .cpsetup, 98

D

- data types
 - conventions, 21
- .data, 98
- description
 - address, 9
- descriptions
 - load instructions, 28
- division by zero, 77
- .double, 98
- .dword, 98
- .dynsym, 99

E

- .end, 99
- endianness, 1
- .endr, 99
- .ent, 99
- exception
 - division by zero, 77
 - unimplemented operation, 79
- exception trap processing, 76
- exceptions, 11
 - floating-point, 11
 - main processor, 11
- execption
 - inexact, 79
 - invalid operation, 77
 - overflow, 78
 - trap processing, 76
 - underflow, 78
- expression
 - type propagation, 23
- expression operators, 21
- expressions, 20
 - precedence, 20
- .extern, 99

F

- .file, 99
- .float, 99
- floating-point
 - computational - description, 64
 - computational - format, 60
 - control register, 74
 - exceptions, 11
 - instruction format, 58
 - instructions, 58
 - load and store, 59
 - move instruction - description of, 72
 - move instructions - format, 71
 - registers, 4
 - relational instruction - description, 69

- relational instruction formats, , 67
- relational operations, 65
- rounding, 79
- floating-point constants, 15
- .fmask, 100
- format
 - address, 8
- formats
 - load and store, 27
- .frame, 100

G

- G value
 - link editor, 19
- general registers, 1
- .globl, 100
- .gpvalue, 100
- .gpword, 100

H

- .half, 101

I

- identifiers, 14
- inexact exception, 79
- instruction set, 25
 - coprocessor, 57
- instructions
 - classes of, 25
 - computational, 35
 - constraints and rules, 25
 - coprocessor interface, 52
 - coprocessor interface - description, , 52, 54
 - floating-point, 58
 - instruction notation, 25
 - jump and branch, 47

load and store - unaligned data, 7
miscellaneous tasks, 52
reorganization rules, 25
special, 52
invalid operation exception, 77

J

jump and branch instructions, 25, 47
 descriptions, 49
 formats, 47

K

keyword statements, 20
KPIC Fortran compiler option, 106

L

.lab, 101
label definitions
 statements, 19
.lcomm, 101
leaf routines, 82
lexical conventions, 13
link editor
 -G option, 19
linkage
 conventions, 81
 program design, 82
load and store
 floating-point, 59
load and store instructions
 formats, 27
load instructions
 delayed, 25
 description, 28
 lb (load byte), 8
 lbu (load byte unsigned), 8
 lh (load halfword), 8

lhu (load halfword unsigned), 8
lw (load word), 8
lwl (load word left), 7
lwr (load word right), 7
ulh (unaligned load halfword unsigned), 7
ulh (unaligned load halfword), 7
ulw (unaligned load word), 7
.loc, 101

M

.mask, 101
move instructions
 floating-point, 71

N

.nada, 102
non-leaf routines, 82
nop, 95, 96
.nop, 102
null statements, 19

O

.option, 102
.origin, 102
overflow exception, 78

P

precedence in expressions, 20
program design
 linkage, 82
pseudo op-codes, , 95, , , , , , , ,

R

- .rdata, 102
- register, 1
 - endianness, 1
 - format, 1
- registers
 - floating-point, 4
 - general, 1
 - special, 3
- relational operations
 - floating-point, 65
- .repeat, 102

S

- scalar constants, 14
- .sdata, 102
- .section, 103
- .set, 103
- shape of data, 90
- .size, 105
- .space, 105
- special instructions, 25, 52
- special registers, 3
- stack frame, 82
- stack organization- figure, , 84
- statements
 - keyword, 20
 - label definitions, 19
 - null, 19
- store instructions
 - description, 32
 - description - table, 32
 - format, 27
 - sb (store byte), 8
 - sh (store halfword), 8
 - sw (store word), 8
 - swl (store word left), 7

- swr (store word right), 7
- ush (unaligned store halfword), 8
- usw (unaligned store word), 7
- string constants, 16
- .struct, 105
- (symbolic equate), 105
- system control
 - instruction descriptions, 73
 - instruction formats, , 73

T

- .text, 105
- tokens
 - comments, 14
 - constants, 14
 - identifiers, 14
- type propagation in expression, 23
- .type, 105

U

- unaligned data
 - load and store instructions, 7
- underflow exception, 78
- unimplemented operation exception, 79

V

- .verstamp, 105

W

- .weakext, 105
- .word, 105