

**SGI™ Total Performance 900
Storage System User's Guide**

007-4428-001

CONTRIBUTORS

Written by Olivier Clarinval

Illustrated by Dan Young

Production by Karen Jacobson

Engineering contributions by Glenn Stettler and Wendy Nunn.

Cover Design By Sarah Bolles, Sarah Bolles Design, and Dany Galgani, SGI Technical Publications

COPYRIGHT

© 2001 Silicon Graphics, Inc. All rights reserved; provided portions may be copyright in third parties, as indicated elsewhere herein. No permission is granted to copy, distribute, or create derivative works from the contents of this electronic documentation in any manner, in whole or in part, without the prior written permission of Silicon Graphics, Inc.

LIMITED RIGHTS LEGEND

The electronic (software) version of this document was developed at private expense; if acquired under an agreement with the USA government or any contractor thereto, it is acquired as "commercial computer software" subject to the provisions of its applicable license agreement, as specified in (a) 48 CFR 12.212 of the FAR; or, if acquired for Department of Defense units, (b) 48 CFR 227-7202 of the DoD FAR Supplement; or sections succeeding thereto. Contractor/manufacturer is Silicon Graphics, Inc., 1600 Amphitheatre Pkwy 2E, Mountain View, CA 94043-1351.

TRADEMARKS AND ATTRIBUTIONS

Silicon Graphics is a registered trademark, and SGI, the SGI logo, and IRIS InSight are trademarks of Silicon Graphics, Inc.

For regulatory information, see Appendix B.

Record of Revision

Version	Description
001	August 2001 Initial Revision

Contents

Figures	ix
Tables	xi
About This Guide.	xiii
Audience	xiv
Related Publications	xiv
Product Support	xiv
Reader Comments	xv
1. Storage System Features	1
Enclosure Chassis	2
Front Panel LEDs	4
Plug-in Modules	5
Drive Carrier Modules	6
Power Supply Module	10
Input/Output (I/O) Module	12
Cooling Module	14
Dummy Carrier Modules	15
Blank Modules	15
Storage System Bay Numbering Convention	16
2. Setup and Operation	19
Unpacking and Inspecting the Storage System.	20
Connecting the Power Cord	21
Attaching Interface Cables	22
1 x 8 Configuration	22
2 x 4 Configuration	24

SCSI_ID Addressing 25
1x 8 Configuration. 25
2 x 4 Configuration 26
Powering On the Enclosure 27
Powering Off the Enclosure 27
Engaging the Anti-tamper Locks 28
3. Replacing Modules 31
Pre-installation Safety Precautions 32
Dealing with Hardware Faults 32
Continuous Operation during Replacement 32
Replacing Power Supply Modules 33
Replacing Cooling Modules 35
Replacing I/O Modules 36
Replacing Drive Carrier Modules 37
Component Part Numbers 40
4. Troubleshooting 41
Overview 42
Initial Startup Problems 44
System Faults 45
Power Supply Faults 45
Cooling Module Faults. 46
A. Technical Specifications 47
Physical and Environmental Specifications 48
Power Requirements 49
B. Regulatory Information 51
Manufacturer’s Declaration of Conformity 51
FCC Class B Conformance. 52
Industry Canada Notice (Canada Only) 52
CE Notice 53
VCCI Notice (Japan Only) 53
Korean Regulatory Notice. 53
Shielded Cables. 54

Electrostatic Discharge	54
Electromagnetic Emissions	54
Index	55

Figures

Figure 1-1	Front View of an SGI TP900 Storage System	2
Figure 1-2	Rear Module Location in Standard Configuration	2
Figure 1-3	Rear Module Location in Redundant Configuration	3
Figure 1-4	ESI/Ops Panel	4
Figure 1-5	Drive Carrier Module	6
Figure 1-6	Drive Carrier LED Indicators	7
Figure 1-7	Anti-tamper Locks	8
Figure 1-8	Drive Information Label	9
Figure 1-9	Power Supply Module	10
Figure 1-10	Power Supply Indicators	11
Figure 1-11	Ultra-3 SCSI I/O Module	12
Figure 1-12	I/O Modules in 1 x 8 Configuration	13
Figure 1-13	Cooling Module	14
Figure 1-14	Drive Bay Numbering	16
Figure 1-15	Rear Module Locations and Bay Numbering	17
Figure 2-1	Attaching Interface Cable on 1 x 8 Configuration	23
Figure 2-2	Attaching Interface Cable on 2 x 4 Configuration	24
Figure 2-3	1 x 8 SCSI_ID Addressing	25
Figure 2-4	2 x 4 SCSI_ID Addressing	26
Figure 2-5	Activating an Anti-tamper Lock	28
Figure 3-1	Power Supply Module Retaining Bracket	33
Figure 3-2	Power Supply Latch and Handle	34
Figure 3-3	Cooling Module Retaining Bracket	35
Figure 3-4	I/O Module Retaining Bracket	36
Figure 3-5	Releasing the Carrier Handle	38

Figure 3-6	Carrier Camming Lever39
Figure 4-1	ESI/Ops Panel LEDs42

Tables

Table 1-1	ESI/Ops LED States	4
Table 3-1	Component Part Numbers	40
Table 4-1	ESI/Ops LED States	43
Table 4-2	System Faults	45
Table 4-3	Power Supply Faults	45
Table 4-4	Cooling Module Faults.	46
Table A-1	Physical and Environmental Specifications	48
Table A-2	Minimum Power Requirements	49

About This Guide

This guide explains how to operate and maintain the SGI Total Performance (TP) 900 SCSI storage system in the following chapters:

- Chapter 1, "Storage System Features"
- Chapter 2, "Setup and Operation"
- Chapter 3, "Replacing Modules"
- Chapter 4, "Troubleshooting"
- Appendix A, "Technical Specifications"
- Appendix B, "Regulatory Information"

An index completes this guide.

Audience

This guide is written for owners and users of the SGI TP900 SCSI storage system. It presumes general knowledge of SCSI technology and knowledge of the host SGI server, the HBA, and other SCSI devices to which the storage system might be cabled.

Related Publications

Besides this manual and the manuals for the storage system third-party software, you should locate the latest versions of the user's guide for the servers. See *SGI Origin 300 User's Guide* (007-4365-001) for information on the SGI Origin 300 server.

If you do not have these guides, you can find the information online in the following locations:

- IRIS InSight Library. From the Toolchest, select **Help > Online Books > SGI EndUser** or **SGI Admin**, and select the applicable owner's or hardware guide.
- Technical Publications Library. If you have access to the Internet, see the following URL:
<http://techpubs.sgi.com/library/>

Product Support

SGI provides a comprehensive product support and maintenance program for its products:

- If you are in North America and want support for your SGI-supported products, contact the Technical Assistance Center at 1-800-800-4SGI or your authorized service provider.
- If you are outside North America, contact the SGI subsidiary or authorized distributor in your country.

Reader Comments

If you have comments about the technical accuracy, content, or organization of this document, contact SGI. Be sure to include the title and document number of the manual with your comments. (Online, the document number is located in the front matter section of the manual. In printed manuals, the document number is located at the bottom of each page.)

You can contact SGI in any of the following ways:

- Send e-mail to the following address:
techpubs@sgi.com
- Use the Feedback option on the Technical Publications Library Web page:
<http://techpubs.sgi.com>
- Contact your customer service representative and ask that an incident be filed in the SGI incident tracking system.
- Send mail to the following address:
Technical Publications
SGI
1600 Amphitheatre Pkwy., M/S 535
Mountain View, California 94043-1351
- Send a fax to the attention of “Technical Publications” at +1 650 932 0801.

SGI values your comments and will respond to them promptly.

Storage System Features

The SGI TP900 is a 2U-high 8-drive storage system that provides compact, high-capacity, high-availability JBOD (“just a bunch of disks”) storage for supported SGI servers. The enclosure backplane connects the 8 drives on one SCSI bus. As an option, the storage system can also be configured on two SCSI busses (two strings of 4 drives). The SGI TP900 is rack-mountable and is designed to use SCSI Parallel Interface 3 (SPI-3) capable Low Profile (1-inch high) 3.5-inch disk drives. The drive carriers accept SGI-qualified 10,000 or 15,000 rpm U160 SCSI disk drives.

This chapter gives information on the basic features of the SGI TP900 SCSI storage system in the following sections:

- “Enclosure Chassis” on page 2
- “Front Panel LEDs” on page 4
- “Plug-in Modules” on page 5
- “Storage System Bay Numbering Convention” on page 16

Enclosure Chassis

The basic unit of the SGI TP900 storage system is the *enclosure*, which contains the disk drives arranged in two rows of 4 drives, and the drive backplane in the front. The I/O, power supply (PSU), and fan modules are located at the rear of the chassis. The chassis uses two EIA units of rack space, and is fitted with 19-inch rack-mounting features, which enable it to be mounted into standard 19-inch racks.

Figure 1-1 shows the front of the enclosure, with the full complement of 8 disk drive modules.

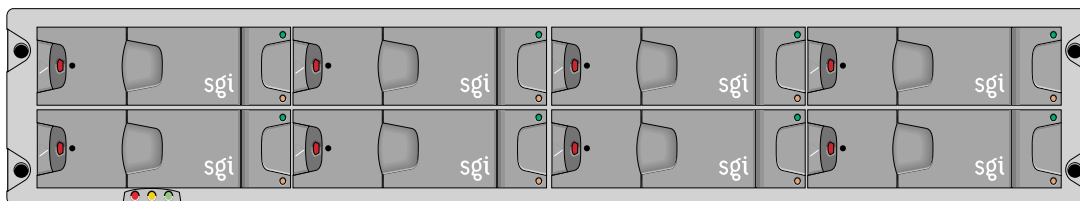

Figure 1-1 Front View of an SGI TP900 Storage System

Figure 1-2 shows the back of an enclosure, which contains one of each of the following: cooling module, cooling blank module, PSU module, PSU blank module, I/O module, and I/O loopback module.

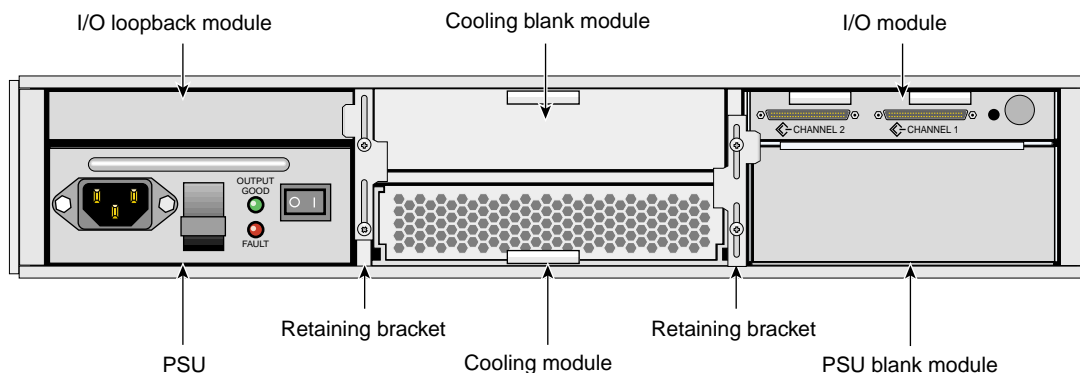

Figure 1-2 Rear Module Location in Standard Configuration

Blank modules occupy unoccupied empty bays and must be in place for proper operation and to ensure correct airflow. The component modules are discussed in detail in “Plug-in Modules” on page 5.

Figure 1-3 shows the back of a fully configured redundant enclosure with two cooling modules, two PSU modules, and two I/O modules.

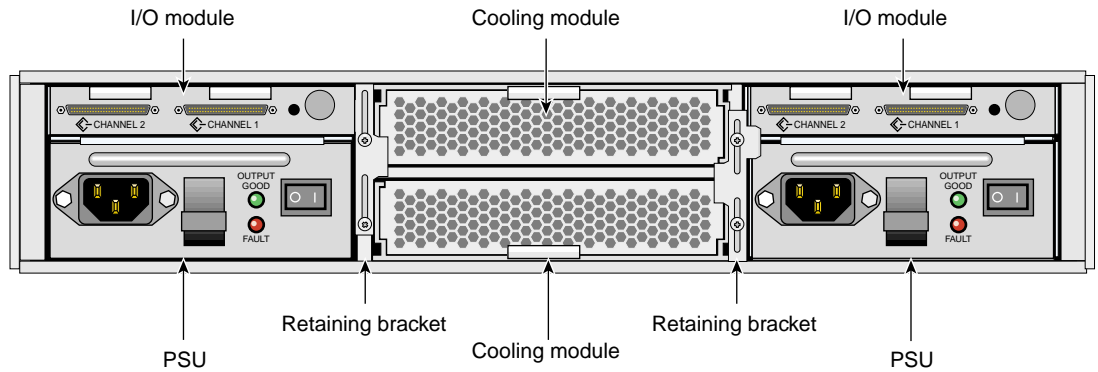

Figure 1-3 Rear Module Location in Redundant Configuration

Front Panel LEDs

The Enclosure System Interface/Operators (ESI/Ops) panel consists of three status indicator LEDs that are located on the front of the enclosure. The ESI/Ops panel provides the enclosure with a micro controller that is used to monitor and control all elements of the enclosure. Each element (system, power, and cooling status) is interfaced to the processor. Figure 1-4 shows the ESI/Ops panel.

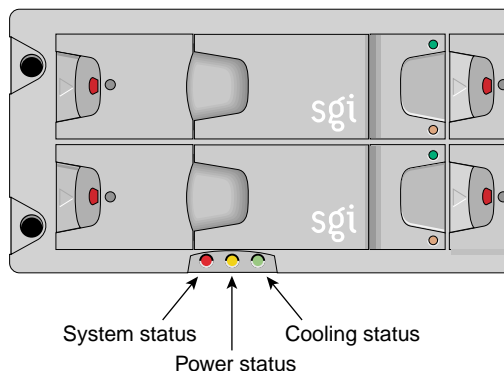

Figure 1-4 ESI/Ops Panel

Table 1-1 summarizes the functions of the LEDs on the ESI/Ops panel. See Chapter 4 for descriptions of common problems, with possible solutions, that can occur with your SGI TP900 system.

Table 1-1 ESI/Ops LED States

LED	LED State and Meaning
System status	Green signifies that power is applied to the enclosure. Amber signifies that the ESI processor has failed.
Power status	Green signifies that the power supplies are functioning normally. Amber signifies that there is a PSU failure in a dual-PSU enclosure. In the event of a PSU failure in a single-PSU enclosure, all LEDs are off.
Cooling status	Green signifies that all fans are functioning normally. Amber signifies that there is a fan failure.

Plug-in Modules

The front of the enclosure contains 8 drive bays, each of which accommodates a plug-in drive carrier module. The rear of the enclosure contains 6 module bays that house power supply, cooling, and SCSI I/O modules. This section describes the component modules in the storage system, as follows:

- Drive Carrier Modules
- Power Supply Module
- Input/Output (I/O) Module
- Cooling Module
- Dummy Carrier Modules
- Blank Modules

Drive Carrier Modules

The drive carrier module comprises a hard disk mounted in a carrier. Each drive bay will house a single 1.0-inch high, 3.5-inch disk drive in its carrier. Each disk drive is enclosed in a die-cast aluminum carrier that provides excellent thermal conduction, radio frequency and electromagnetic induction protection, and maximum physical protection of the drives.

The front cap also supports an ergonomic handle that provides the following functions:

- Camming of carrier into and out of drive bays.
- Spring-loading of the drive into the backplane connector.
- An anti-tamper lock operated by a torx socket type key.

Figure 1-5 shows a drive carrier module.

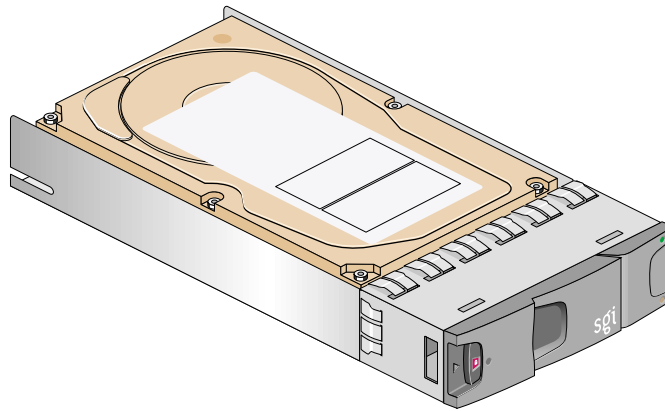

Figure 1-5 Drive Carrier Module

This section discusses other features of the drive carrier module, as follows:

- Drive carrier indicators
- Anti-tamper locks
- Drive information label

Drive Carrier Indicators

Each drive carrier incorporates two indicators, an upper (green) and a lower (amber). In normal operation, the green indicator will be lit and will flicker as the drive operates. Figure 1-6 shows the drive carrier indicators.

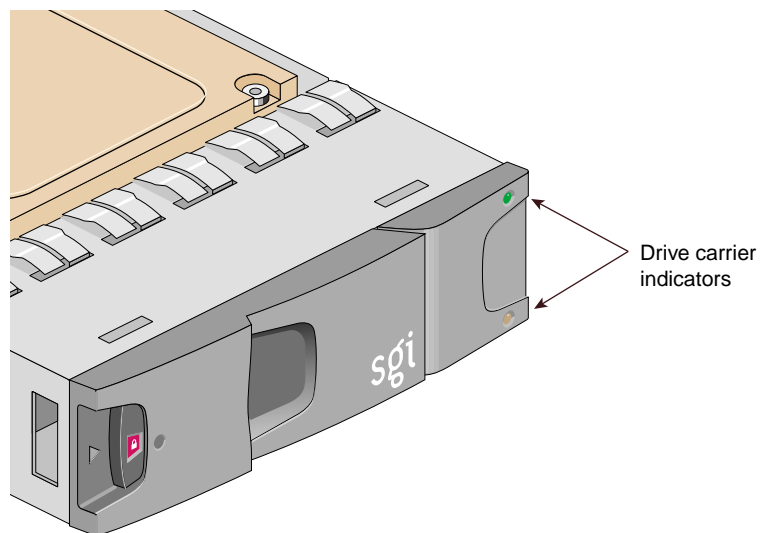

Figure 1-6 Drive Carrier LED Indicators

Anti-tamper Locks

Anti-tamper locks are fitted in the drive carrier handles and are accessed through the small cutout in the latch section of the handle. These are provided to disable the normal “pinch” latch action of the carrier handle. See “Engaging the Anti-tamper Locks” on page 28 for instructions on how to engage or disengage the anti-tamper lock. Figure 1-7 shows the location of the anti-tamper locks.

Note: The drives will operate with the locks either engaged or disengaged.

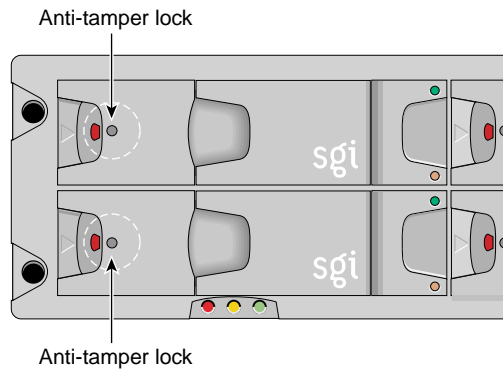

Figure 1-7 Anti-tamper Locks

Drive Information Label

A label containing drive information is located on the drive carrier handle. The label indicates the size (xxx GB), speed (xx kRPM), and the last five numbers of the serial number of the drive installed in the carrier. See Figure 1-8 for an illustration of the drive information label.



Figure 1-8 Drive Information Label

Power Supply Module

One 350-Watt plug-in power supply module (PSU) is mounted in the rear of the system. Optionally, a second power supply module can be fitted to provide redundancy. Figure 1-9 shows a PSU module.

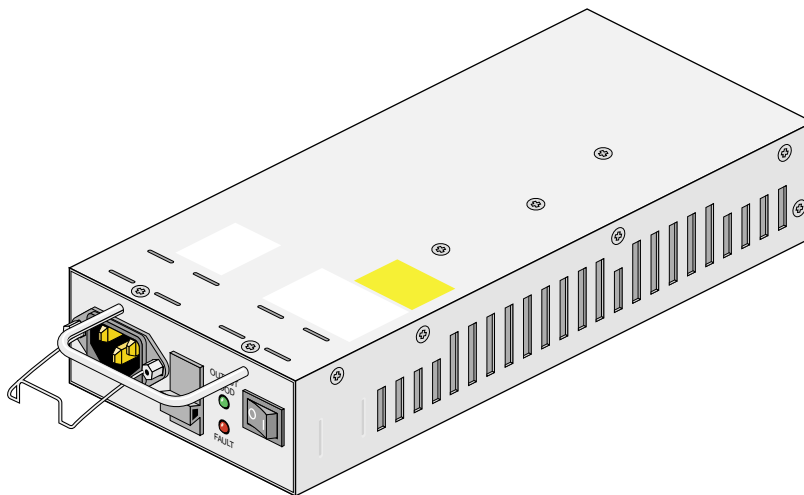

Figure 1-9 Power Supply Module

Power supply voltage operating ranges are nominally 115 V or 230 V, and are selected automatically.

In a redundant configuration, the modules operate together; if one fails, the other maintains the power supply while the faulty unit is replaced.

Important: Module replacement should only take a few minutes to perform but must be completed within 10 minutes from removal of the failed module. Alternatively, if a replacement power supply module is not available, a power supply blanking module must be fitted after removing the faulty module.

Two LED indicators are located on the front panel of the power supply. Figure 1-10 shows the power supply indicators.

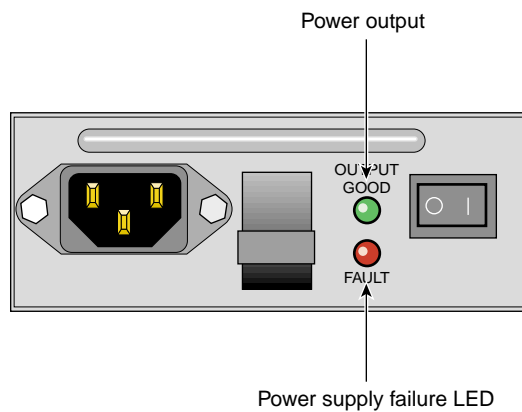

Figure 1-10 Power Supply Indicators

The green LED indicates good power output. The amber LED indicates power supply failure.

Input/Output (I/O) Module

Two I/O modules are mounted in the rear of the system utilizing Ultra-3 SCSI interfacing with the host computer system. Two I/O module configurations are available, as follows:

- The 1 x 8 configuration is used to create a SCSI bus structure with one string of 8 drives. It consists of one standard I/O module with two VHDCI connectors for main I/O purposes and a switch to set the SCSI-ID range. The second module is a loopback PCB with no external connectors.
- The 2 x 4 configuration is used to create a SCSI bus structure with two strings of 4 drives. The two modules are the standard I/O modules with two VHDCI connectors for main I/O purposes.

Figure 1-11 shows a standard Ultra-3 I/O module.

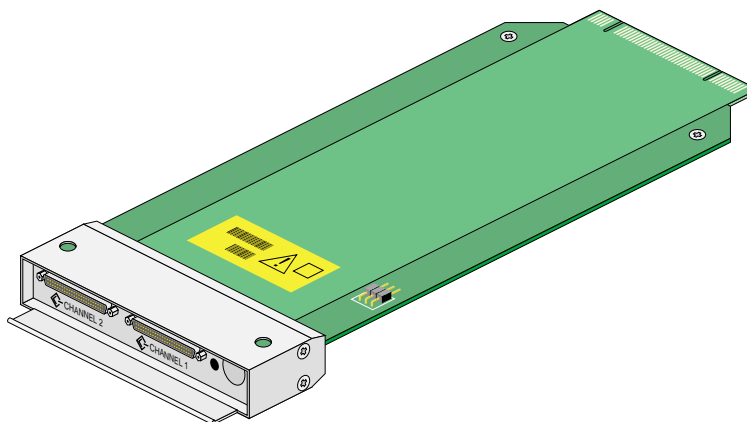

Figure 1-11 Ultra-3 SCSI I/O Module

Figure 1-12 shows the rear view of an enclosure with I/O modules in a 1 x 8 configuration.

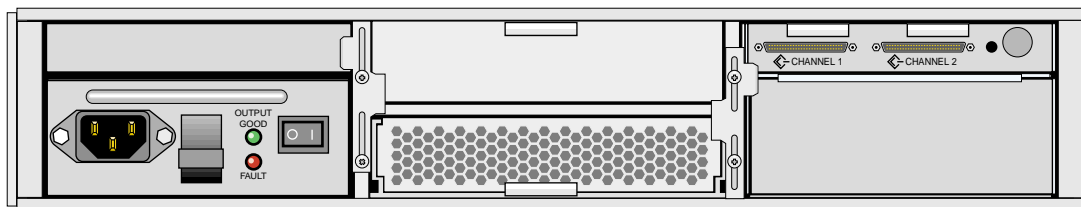

Figure 1-12 I/O Modules in 1 x 8 Configuration

Cooling Module

One cooling plug-in module is mounted in the rear of the system. Optionally, a second cooling module can be fitted to provide greater redundancy. The cooling modules connect to the backplane for power and status signal connections. The modules pull air from a plenum behind the drive backplane and exhaust the warm air at the rear of the enclosure. Figure 1-13 shows a cooling module.

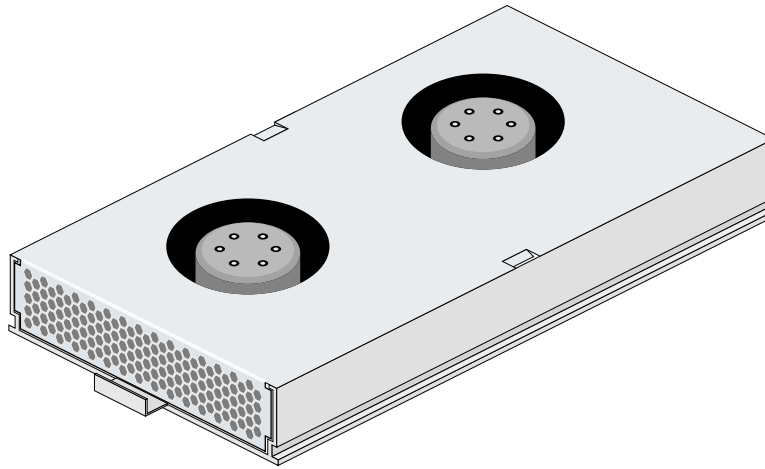

Figure 1-13 Cooling Module

In a redundant configuration, the modules operate together; if one fails, the other maintains adequate cooling to the system while the faulty unit is replaced.

Caution: Do not remove a module unless a replacement can be immediately added. This is particularly important in a single-cooling module system, which will very quickly overheat unless a properly functioning cooling module is installed.

Dummy Carrier Modules

Dummy carrier modules are provided for installation in all unused drive bays. They are designed as integral drive module front caps with handles and must be installed in all unused drive bays to maintain a balanced airflow.

Caution: If any modules are missing, operation of the enclosure will disrupt the airflow and the drives will not receive sufficient cooling. It is essential that all apertures be filled before operating the unit. Dummy carriers are available for this purpose.

Blank Modules

Blank modules must be fitted in all vacant bays at the rear of the enclosure to maintain airflow and ensure correct operation. Blank modules are available for the cooling module bays and the power supply module bays.

Caution: If any modules are missing, operation of the enclosure will disrupt the airflow and the drives will not receive sufficient cooling. It is essential that all apertures be filled before operating the unit. Blank modules are available for this purpose.

Storage System Bay Numbering Convention

A bay is defined as the space required to house a single module. In the front of the enclosure, this is the space required by a single 1.0-inch high 3.5-inch disk drive in its carrier module. In the rear of the enclosure, this is the space required by a single PSU, I/O, or cooling module.

The SGI TP900 system has 8 drive bays in the front of the enclosure—2 rows of 4 bays. A front bay is identified by a row/column fraction. Rows are numbered 1 to 2 from top to bottom, and columns are numbered 1 to 4 from left to right, viewed from the front. For example, drive 1/2 refers to the bay located in row 1 (top) and column 2 (second from the left).

Figure 1-14 shows the numbering convention for the drive modules.

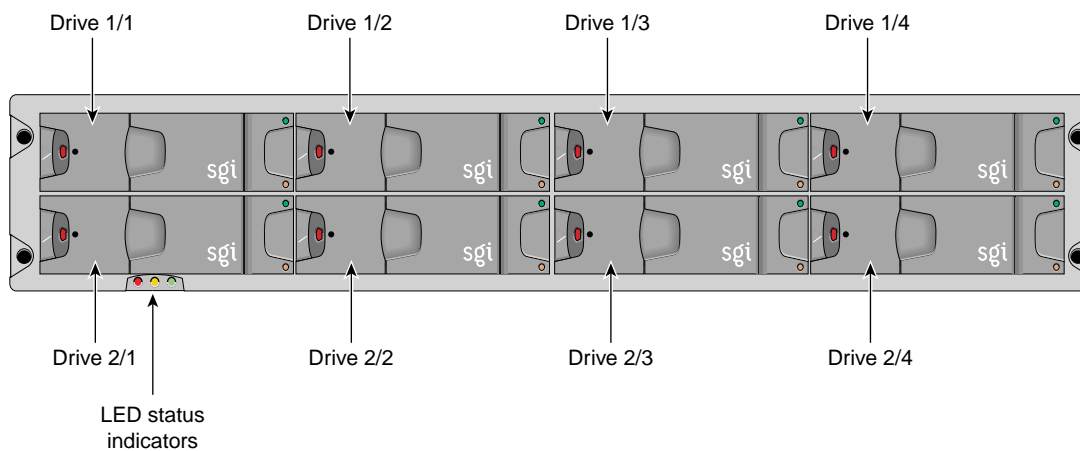

Figure 1-14 Drive Bay Numbering

The SGI TP900 system has 6 module bays at the rear—2 rows of 3 bays. A rear bay is identified by a row/column fraction. Rows are numbered 1 to 2 from top to bottom, and columns are numbered 1 to 3 from right to left, viewed from the rear. For example, module 2/3 refers to the bay located in row 2 (bottom) and column 3 (third from the right).

Figure 1-15 shows the location and numbering convention for the rear-bay modules.

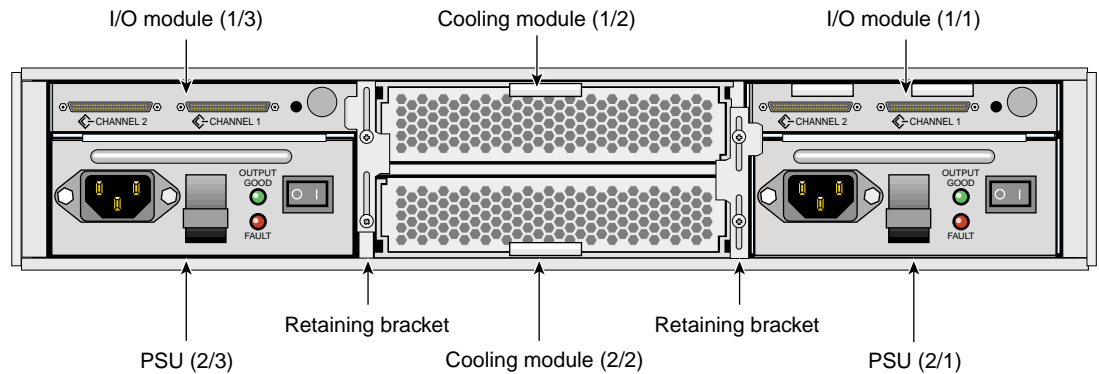

Figure 1-15 Rear Module Locations and Bay Numbering

Setup and Operation

This chapter describes how to set up and operate your SGI TP900 storage system in the following sections:

- “Unpacking and Inspecting the Storage System” on page 20
- “Connecting the Power Cord” on page 21
- “Attaching Interface Cables” on page 22
- “SCSI_ID Addressing” on page 25
- “Powering On the Enclosure” on page 27
- “Powering Off the Enclosure” on page 27
- “Engaging the Anti-tamper Locks” on page 28

Unpacking and Inspecting the Storage System

Remove the storage system from the packaging container and check that all accessories are included. Inspect the packaging container for evidence of mishandling during transit. If the packaging container is damaged, photograph it for reference. After removing the contents, keep the damaged container and the packing materials.

Inspect the storage system and accessories for damage. If the contents appear damaged, file a damage claim with the carrier immediately. For installations under U.S. auspices, notify the Customer Support Call Center (CSCC) for any missing, incorrect, or damaged items. Elsewhere, follow local policies.

Connecting the Power Cord

To connect a power cord to power supply modules, follow these steps:

1. For redundant configurations, attach the bifurcated power cord to the power supply modules.
2. Attach the power cord to the in-line IEC connector.

Note: These power-splitting cables are provided so that the system is operated from a single power source, thus providing a single point of disconnect.

A standby LED on the ESI/Ops panel indicates whether AC power is present.

For non-redundant systems using one power supply module, connect the power cord to the power supply module and to the power source.

Perform these checks to ensure that a safe grounding system is provided:

1. If a rack distribution system is being used, perform these tasks:
 - Ensure power is removed from the rack.
 - Connect the supplied power cord to the rack distribution and the enclosure.
2. If a direct connection is made with the power cord, ensure that it is connected to the enclosure.

Caution: Some electrical circuits could be damaged if external signal cables or power control cables are present during the grounding checks.

3. Check for continuity between the earth pin of the power cord on one of the power supply modules (or rack inlet) and any exposed metal surface of the SGI TP900 enclosure.

Attaching Interface Cables

This section explains which of the connectors on the I/O modules should be used to connect external Ultra-3 SCSI-compatible cables.

As seen from the rear of an I/O module, the connector on the right-hand side connects to channel 1 (device bays 1/1, 2/1, 1/2, 2/2). The connector on the left-hand side connects to channel 2 (device bays 1/3, 2/3, 1/4, 2/4). This applies to I/O modules installed in either location (1/1 or 1/3).

1 x 8 Configuration

Connect the interface cable to the channel 1 connector and attach a terminator to the other I/O connector, as shown in Figure 2-1.

Caution: External termination must be fitted to the unused I/O connector to ensure termination of the SCSI bus. I/O modules do not contain any bus termination.

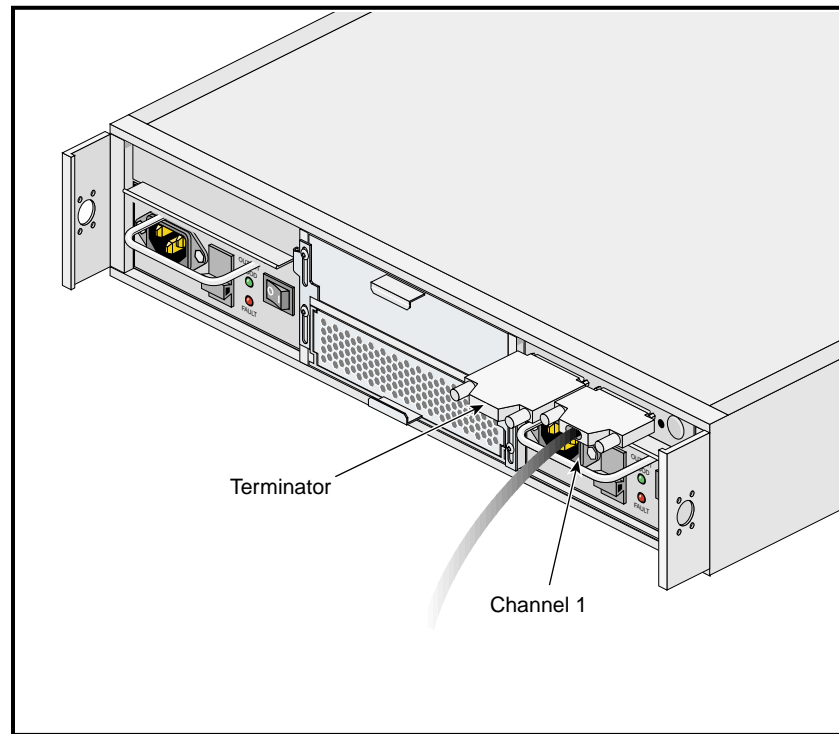

Figure 2-1 Attaching Interface Cable on 1 x 8 Configuration

2 x 4 Configuration

Connect an interface cable to the channel 1 connector on I/O module 1/1, and then connect another interface cable to the channel 2 connector on I/O module 1/3, as shown in Figure 2-2. Attach terminators to the two unused I/O connectors.

Caution: External termination must be fitted to all unused I/O connectors to ensure termination of the SCSI bus. I/O modules do not contain any bus termination. If you are using only one of the two I/O modules, a termination is required only on the connector that corresponds to the channel being used, as shown in Figure 2-2.

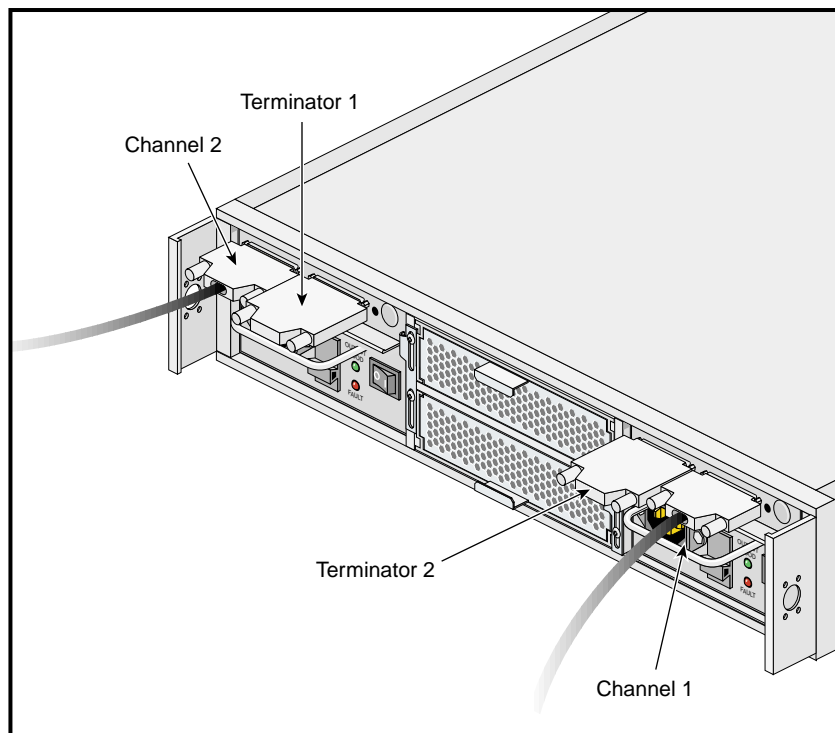

Figure 2-2 Attaching Interface Cable on 2 x 4 Configuration

Important: In a 2 x 4 configuration, the termination for each channel is located on the other I/O module from where the interface cable is connected. For example, the terminator for channel 1 is located on the left I/O module (1/3), whereas the interface cable is connected to the right I/O module (1/1). See Figure 2-2 for an illustration of the proper cable and terminator configuration.

SCSI_ID Addressing

This section shows the SCSI_ID base address for each drive in 1 x 8 and 2 x 4 configurations. See “Storage System Bay Numbering Convention” on page 16 for the drive module numbering convention.

1x 8 Configuration

In a 1 x 8 configuration with a loopback module installed, the single I/O module (1/1) controls the range of all the drives. Figure 2-3 shows the SCSI_ID base address for each drive.

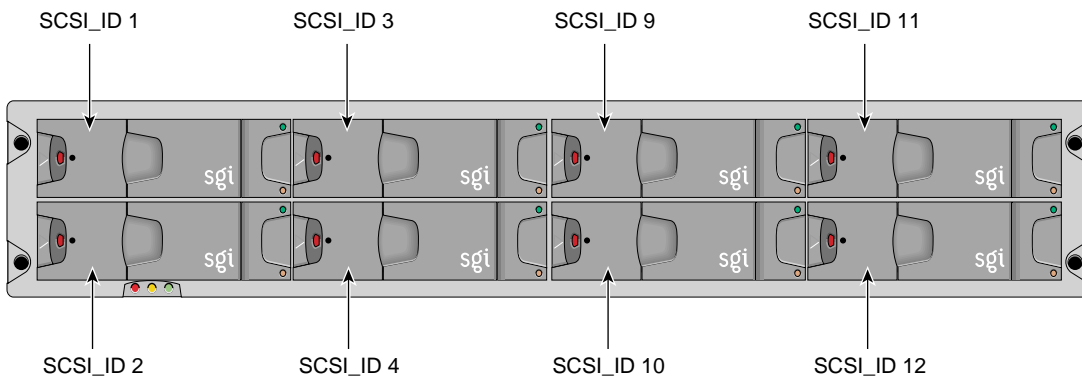

Figure 2-3 1 x 8 SCSI_ID Addressing

2 x 4 Configuration

In a 2 x 4 configuration, the range defined by I/O module 1/3 controls the IDs of the right 4 drives (1/3, 1/ 4, 2/3, 2/4), and I/O module 1/1 controls the IDs of the left 4 drives (1/1, 1/2, 2/1, 2/2). Figure 2-4 shows the SCSI_ID base address for each drive.

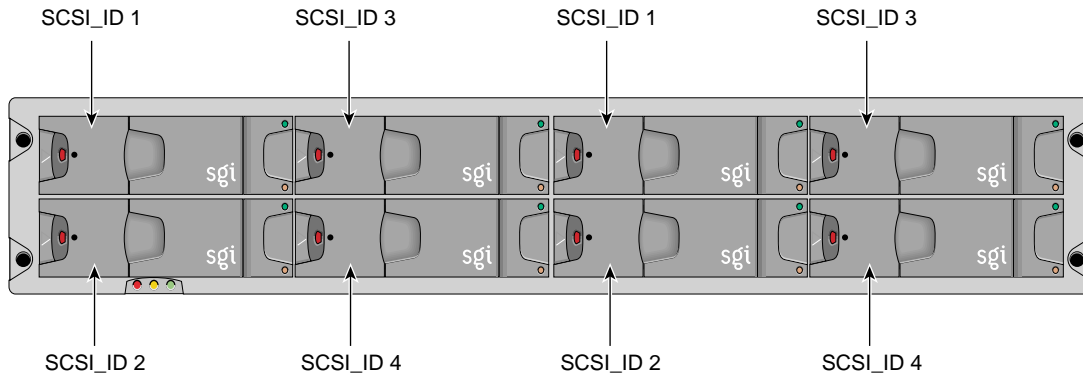

Figure 2-4 2 x 4 SCSI_ID Addressing

Powering On the Enclosure

Follow these steps to power on the enclosure:

Caution: Before powering on the enclosure, ensure that all the modules are firmly seated in their correct bays. Do not operate the subsystem until the ambient temperature is within the specified operating range. If the drives have been recently installed, ensure they have had time to acclimatize before operating them.

1. Apply AC power to the enclosure. Turn the power supply module(s) switch to the ON position. The green Power Output LED should be lit and the red Fault LED should be off.

Note: In a dual-PSU system, it does not matter which PSU is powered on first.

2. All LEDs on the ESI/Ops Panel should be lit green, and the disk drive motors should start when the enclosure power is activated.

Note: All LEDs on the ESI/Ops panel should be lit green when power is applied, which indicates that the system is functioning correctly. If any show amber, then a problem exists. See Chapter 4 for troubleshooting information.

All drives in the enclosure should automatically start their motors after power is applied. If this has not occurred, there may be a power problem (a power fault indication would normally be active).

Powering Off the Enclosure

To power off the enclosure, switch off the power supply modules installed in the enclosure.

Engaging the Anti-tamper Locks

Each drive carrier handle has an anti-tamper lock, which is accessed through the small cutout in the latch section of the handle. Drives are supplied with the locks set in the unlocked position. A lock key is provided with the system.

Follow these steps to activate the locks:

1. Carefully insert the lock key into the lock in the handle. See Figure 2-5 for the location of the anti-tamper lock.
2. Rotate the key in a clockwise direction until the indicator is visible in the aperture beside the key.

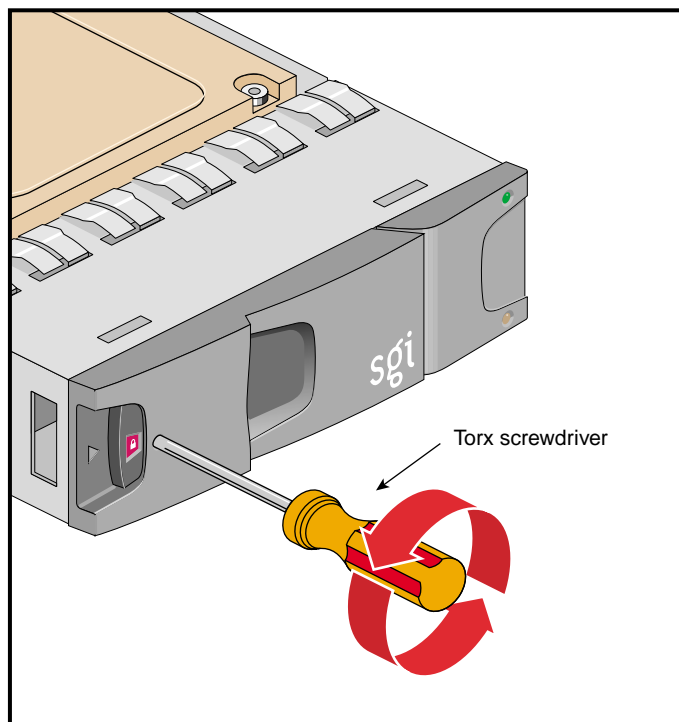

Figure 2-5 Activating an Anti-tamper Lock

3. Remove the key.

4. Repeat this procedure for each lock that you want to activate.

To de-activate a lock, carefully insert the lock key into the lock in the handle, and rotate the key in a counter-clockwise direction until the indicator is no longer visible in the aperture beside the key.

Note: A drive carrier cannot be installed if its anti-tamper lock is activated outside of the enclosure.

Replacing Modules

This chapter shows how to replace all plug-in modules in the SGI TP900 enclosure. The following sections are covered:

- “Pre-installation Safety Precautions” on page 32
- “Dealing with Hardware Faults” on page 32
- “Continuous Operation during Replacement” on page 32
- “Replacing Power Supply Modules” on page 33
- “Replacing Cooling Modules” on page 35
- “Replacing I/O Modules” on page 36
- “Replacing Drive Carrier Modules” on page 37
- “Component Part Numbers” on page 40

Pre-installation Safety Precautions

Observe the following safety precautions.

Warning: Hazardous voltage and current levels are present inside the storage subsystem. The replacement of rear-bay modules should be performed only by technically qualified personnel.

Caution: Do not remove a module unless a replacement can be immediately added. The system must not be run without all modules in place.

Caution: Follow electrostatic discharge (ESD) precautions while replacing the plug-in modules. Avoid contact with the backplane components and module connectors.

Dealing with Hardware Faults

Ensure that you have obtained a replacement module of the same type before removing any faulty module.

Caution: If the SGI TP900 subsystem is powered on and you remove any module, replace it immediately. If the subsystem is used without its modules or blanking plates for more than a few minutes, the enclosure can overheat, causing power failure and data loss. Such use will invalidate the warranty.

Continuous Operation during Replacement

If the enclosure contains two power supply modules, one of them can maintain power to the subsystem while the other is replaced. A cooling module can be replaced without SCSI data flow interruption. I/O modules can be replaced with the system powered up, but the SCSI Channel will be down and data flow will be interrupted.

Replacing Power Supply Modules

Follow these steps to replace a power supply module or a power supply blank module on the SGI TP900 enclosure:

Warning: Hazardous voltage and current levels are present inside the storage subsystem. The replacement of rear-bay modules should only be performed by technically qualified personnel.

Caution: Do not remove a module unless a replacement can be immediately added. The system must not be run without all modules in place.

1. Switch off the faulty module and disconnect the power supply cord.

Note: If you have two power supply modules installed, one power supply module will maintain power to the enclosure while the other module is replaced.

2. Loosen the screws securing the retaining bracket (see Figure 3-1) and slide the bracket upwards, until it is clear of the side of the power supply module.

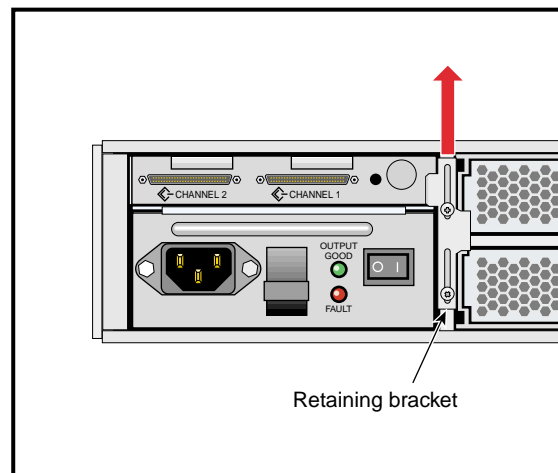

Figure 3-1 Power Supply Module Retaining Bracket

3. Grip the handle, lift the latch on the front of the PSU, and remove the PSU from the enclosure.
4. To install a replacement module, grip the handle, lift the latch on the front of the PSU, and slide the module into the enclosure (see Figure 3-2). The latch engages automatically.

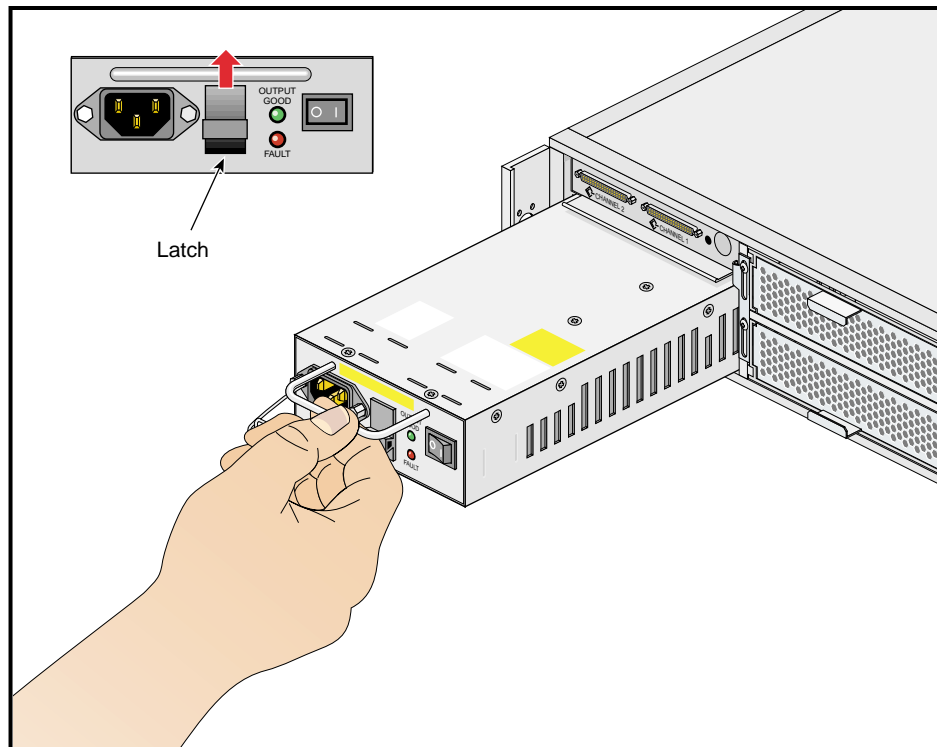

Figure 3-2 Power Supply Latch and Handle

5. Return the retaining bracket to the center position and tighten the securing screws.
6. Connect the power supply cord to the power source.

Replacing Cooling Modules

Follow these steps to remove a cooling module or a cooling blank module from the SGI TP900 enclosure:

Caution: Do not remove a module unless a replacement can be immediately added. This is particularly important in a single-cooling module system which will very quickly overheat without a properly functioning cooling module installed.

1. Loosen the screws securing both retaining brackets (see Figure 3-3), and slide the brackets up or down, depending on the location of the cooling module to be installed, until they are clear of the sides of the cooling module.

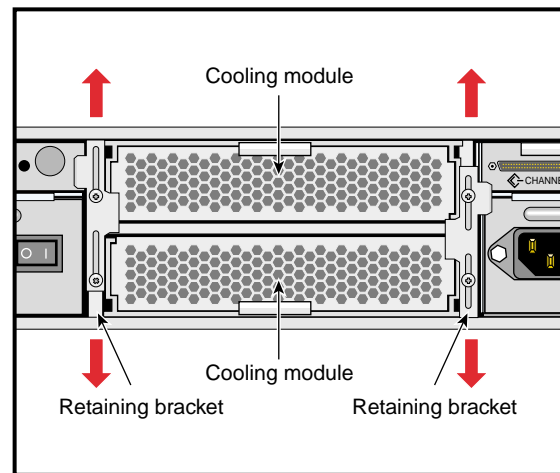

Figure 3-3 Cooling Module Retaining Bracket

2. Slide the cooling module out of the enclosure.
3. Slide the replacement cooling module fully into the enclosure. You will feel a slight resistance as you set the cooling module connector in place and as the rear face of the tray is flush with the rear members of the enclosure.
4. Return the retaining brackets to the center position and tighten the securing screws.

Replacing I/O Modules

Follow these steps to remove an I/O module from the SGI TP900 enclosure:

Caution: Do not remove a module unless a replacement can be immediately added. The system must not be run without all modules in place.

1. Loosen the screws securing the retaining bracket (see Figure 3-4) and slide the bracket down, until it is clear of the side of the I/O module.

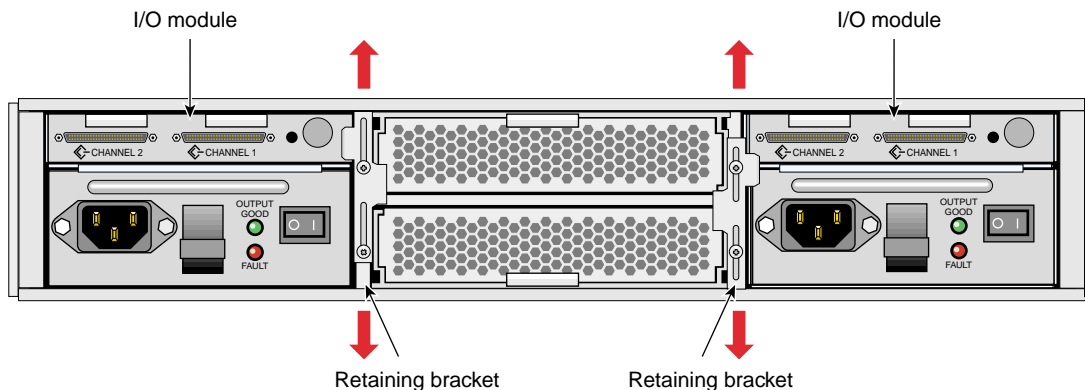

Figure 3-4 I/O Module Retaining Bracket

2. Slide the I/O module out of the enclosure.
3. Slide the replacement I/O module fully into the enclosure. You will feel a slight resistance as you insert the card in the PCI connector and as the rear face of the I/O module becomes flush with the rear face of the PSU.
4. Return the retaining bracket to the center position and tighten the securing screws.

Replacing Drive Carrier Modules

Caution: Follow electrostatic discharge (ESD) precautions while replacing the drive carriers. Avoid contact with the backplane components and module connectors.

Follow these steps to remove and replace a drive carrier module from the SGI TP900 enclosure:

Caution: Do not remove a drive carrier unless a replacement or a dummy carrier can be immediately added. The system must not be run without all modules in place. Any unused drive bays must be fitted with a dummy carrier module.

1. Spin down the drive prior to removal, using the operating system.

Caution: Damage can occur to a drive if it is removed while still spinning. If you cannot use the operating system to spin down the drives prior to removal, perform all steps of the following procedure to ensure that the drive has stopped prior to removal.

2. Release the carrier handle by pressing the latch in the handle towards the right.

Note: The anti-tamper lock must be off. See “Engaging the Anti-tamper Locks” on page 28 for instructions on disengaging the anti-tamper lock.

3. Gently withdraw the drive carrier module approximately 1 inch (25mm), and then wait 30 seconds.
4. Withdraw the module from the drive bay.

5. Release the handle of the replacement carrier by pressing the latch in the handle towards the right, as shown in Figure 3-5. Insert the carrier into the enclosure.

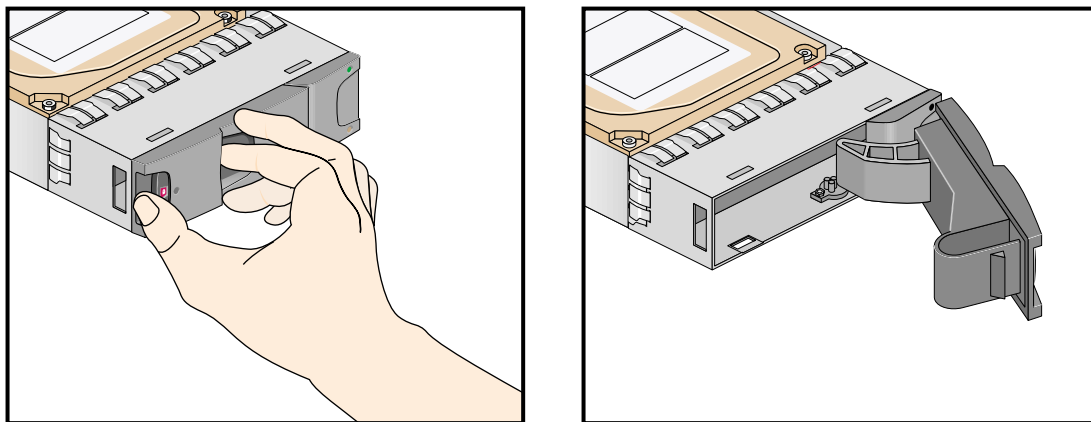

Figure 3-5 Releasing the Carrier Handle

Important: Ensure that the carrier is orientated so that the drive is uppermost and the handle opens from the left.

6. Gently slide the carrier all the way into the enclosure until it is stopped by the camming lever on the right of the carrier, as shown in Figure 3-6.

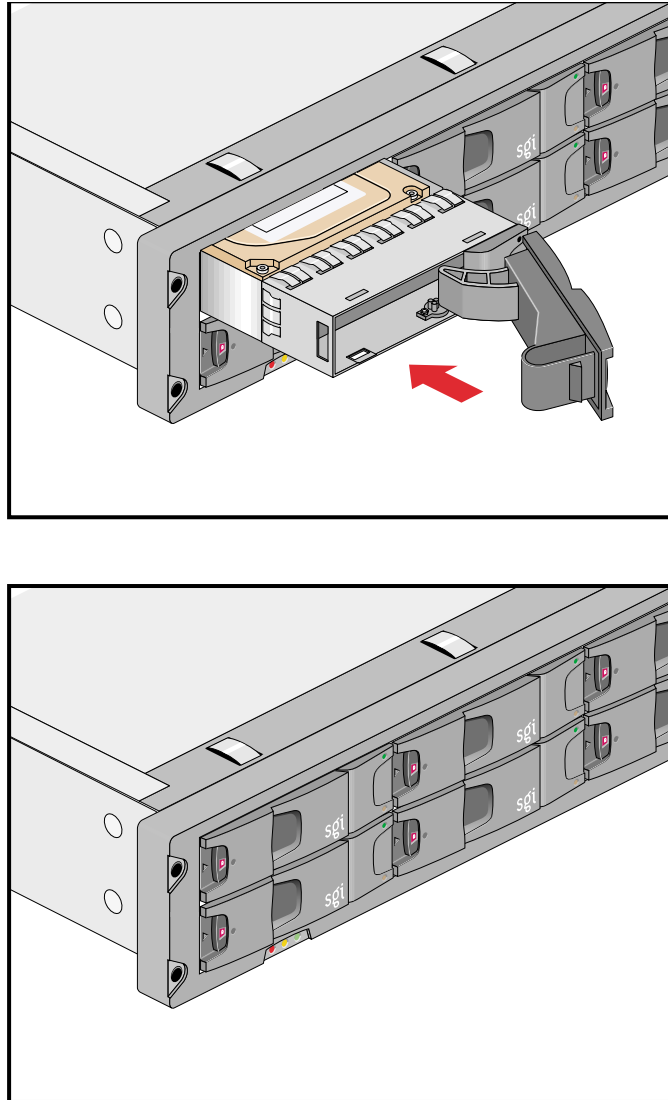

Figure 3-6 Carrier Camming Lever

7. Push the carrier handle into place—the camming foot on the base of the carrier will engage in a slot in the enclosure. Continue to push firmly until the handle fully engages. A click should be heard as the latch engages and holds the handle closed.

Component Part Numbers

Table 3-1 lists part numbers for the following replaceable components.

Table 3-1 Component Part Numbers

Component	Part Number
Power supply module	013-3437-001
I/O module	013-3436-001
Loopback module	013-3435-001
Cooling module	013-3438-001
Bifurcated power cable	7260832
Dummy drive carrier	013-3439-001

Troubleshooting

This chapter helps you identify and solve problems that might occur while you are using the SGI TP900 storage system. The following sections are covered:

- “Overview” on page 42
- “Initial Startup Problems” on page 44
- “System Faults” on page 45
- “Power Supply Faults” on page 45
- “Cooling Module Faults” on page 46

Overview

The SGI TP900 enclosure includes a processor and associated monitoring and control logic to enable it to diagnose problems within the enclosure's power, cooling, and drive systems.

All rear-mounted modules are designed to be maintained by trained technicians. Each power supply module has a status LED.

A green LED is always a positive indicator, and an amber LED indicates that there is a critical fault within the module. The ESI/Ops panel displays the aggregated status of all the modules. The ESI/Ops panel LEDs are shown in Figure 4-1.

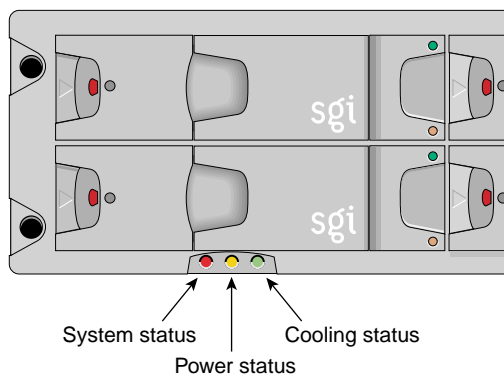

Figure 4-1 ESI/Ops Panel LEDs

Table 4-1 summarizes the functions of the LEDs on the ESI/Ops panel and refers to the sections that cover specific component failures.

Table 4-1 ESI/Ops LED States

LED	LED State and Meaning	See This Section
System status	Green signifies that power is applied to the enclosure. Amber signifies that the ESI processor has failed.	“System Faults” on page 45
Power status	Green signifies that the power supplies are functioning normally. Amber signifies that there is a PSU failure in a dual-PSU enclosure. In the event of a PSU failure in a single-PSU enclosure, all LEDs are off.	“Power Supply Faults” on page 45
Cooling status	Green signifies that all fans are functioning normally. Amber signifies that there is a fan failure.	“Cooling Module Faults” on page 46

The following sections explain how to troubleshoot initial startup problems, system faults, power supply faults, and cooling module faults.

Initial Startup Problems

Check that you have wired the subsystem correctly. Call your supplier for a replacement part if:

- Cords are missing or damaged.
- Plugs are of the wrong type.
- Cords are too short.

Use the following checklist if your computer does not recognize the SGI TP900 system:

- Check that the Ultra-3 SCSI interface cables from the enclosure to the host computer are fitted correctly.
- Check the SCSI ID settings on your system host.
- Check that the LEDs on all installed drive carrier modules are illuminated green. Note that the drive LEDs will not be lit during drive spinup.
- Check that all drive carrier modules have been correctly installed.
- Check the I/O module setup as follows:
 - Check that the I/O module has been correctly installed and all external links and cables are securely fitted.
 - Check that the maximum cable length (10 m) has not been exceeded.
 - Check that the correct termination is fitted on all unused ports.
 - Check that different IDs have been selected for all devices on a channel.

System Faults

Table 4-2 explains how to troubleshoot a system status LED that is amber.

Table 4-2 System Faults

Symptom	Cause	Action
The system LED is amber.	The ESI processor has detected an internal fault.	<ol style="list-style-type: none"> 1. Check for other amber LED indicators on the power supply modules. If there is a PSU error, there may be a communications problem with that power supply module. Remove and then re-fit the module. If the problem persists, change the module. 2. Check for other amber LED indicators on the drive carriers. If none are evident, there may be either an ESI processor problem or a backplane problem.

Power Supply Faults

Table 4-3 explains how to troubleshoot a power supply module status LED that is amber.

Table 4-3 Power Supply Faults

Symptom	Cause	Action
Operator panel power supply LED is amber. OR One or more power supply module LEDs are amber.	Any power fault.	<ol style="list-style-type: none"> 1. Check that the AC power connection to the power supply module is live. 2. Check that the power supply module is switched on. 3. Disconnect the power supply module from AC power, remove the module from the system, and then re-install it. If the problem persists, replace the power supply module.

Cooling Module Faults

Table 4-4 explains how to troubleshoot a cooling module status LED that is amber.

Table 4-4 Cooling Module Faults

Symptom	Cause	Action
Operator panel cooling LED is amber.	One or more fans within the cooling modules have failed	Remove the module(s) from the system, and then re-install it. If problem persists, replace the faulty cooling module.

Technical Specifications

This appendix lists technical specifications of the SGI TP900 storage system in these sections:

- “Physical and Environmental Specifications” on page 48
- “Power Requirements” on page 49

Physical and Environmental Specifications

Table A-1 shows the physical and environmental specifications for the SGI TP900 storage system.

Table A-1 Physical and Environmental Specifications

Height	85.7 mm (3.37 in.)
Width	447 mm (17.6 in.)
Depth	545 mm (21.46 in.)
Weight	Maximum configuration: 22 Kg (48.5 lb) Empty enclosure: 6.5 Kg (14.3 lb) Power supply module: 1.75 Kg (3.85 lb) Cooling module: 1 Kg (2.2 lb) I/O module: 1.25 Kg (2.75 lb)
Temperature, operating	+10 °C (+50 °F) to +35 °C (+95 °F) (single-cooling module) +10 °C (+50 °F) to +40 °C (+104 °F) (dual-cooling module)
Temperature, non-operating	+0 °C (+32 °F) to +50 °C (+122 °F)
Temperature, shipping	-40 °C (-40 °F) to +60 °C (+140 °F)
Humidity	20% to 80% non-condensing (operating) 8% to 80% non-condensing (non-operating) 5% to 100% condensing but not precipitating (shipping)
Altitude, operating	0 to 2133 m (0 to 7000 ft.) 10,000 ft. at maximum ambient temperature of +35 °C
Altitude, non-operating	-305 to 12,192 m (-1,000 to 40,000 ft.)

Power Requirements

Table A-2 lists the minimum power requirements for the SGI TP900 storage system.

Table A-2 Minimum Power Requirements

Factor	Requirement
Voltage	110/220 VAC auto-sensing worldwide
Frequency	50/60 Hz
Maximum power consumption	350 W maximum continuous

Regulatory Information

This section contains Class B warnings and specifications. The SGI TP900 rackmountable storage system conforms to several national and international specifications and European Directives listed in “Manufacturer’s Declaration of Conformity”.

Caution: The SGI TP900 storage system has several governmental and third-party approvals, licenses, and permits. Do not modify this product in any way that is not expressly approved by SGI. If you do, you may lose these approvals and your governmental agency authority to operate this device.

Manufacturer’s Declaration of Conformity

A “Manufacturer’s Declaration of Conformity” is available on the Web. Look at your system (regulatory) label on the rear of your workstation to determine your CMN (model) number, which you need to identify your Declaration of Conformity, and to find the series number of your processor.

To locate the information on the Web, enter the following URL:

<http://www.sgi.com/compliance/index.html>

FCC Class B Conformance

This equipment complies with Part 15 of the FCC Rules. Operation is subject to the following two conditions:

- This device may not cause harmful interference.
- This device must accept any interference received, including interference that may cause undesired operation.

This equipment has been tested and found to comply with the limits for a Class B digital device, pursuant to Part 15 of the FCC Rules. These limits are designed to provide reasonable protection against harmful interference in a residential installation. This equipment generates, uses and can radiate radio frequency energy and, if not installed and used in accordance with the instructions, may cause harmful interference to radio communications. However, there is no guarantee that interference will not occur in a particular installation. If this equipment does cause harmful interference to radio or television reception, which can be determined by turning the equipment off and on, you are encouraged to try to correct the interference by using one or more of the following measures:

- Reorient or relocate the receiving antenna.
- Increase the separation between the equipment and receiver.
- Connect the equipment into an outlet on a circuit different from that to which the receiver is connected.
- Consult the dealer or an experienced radio/TV technician for help.

Industry Canada Notice (Canada Only)

Cet appareil numérique n'émet pas de perturbations radioélectriques dépassant les normes applicables aux appareils numériques de Classe B prescrites dans le Règlement sur les interférences radioélectriques établi par le Ministère des Communications du Canada.

CE Notice

Marking by the “CE” symbol indicates compliance of the device to directives of the European Community. A “Declaration of Conformity” in accordance with the above standards has been made and is available from SGI upon request.



VCCI Notice (Japan Only)

この装置は、情報処理装置等電波障害自主規制協議会（VCCI）の基準に基づくクラスB情報技術装置です。この装置は、家庭環境で使用することを目的としていますが、この装置がラジオやテレビジョン受信機に近接して使用されると、受信障害を引き起こすことがあります。取扱説明書に従って正しい取扱いをして下さい。

Korean Regulatory Notice

이 기기는 가정용으로 전자파적합등록을 한 기기로서 주거지역에서는 물론 모든 지역에서 사용할 수 있습니다.

Shielded Cables

The SGI TP900 storage system is FCC-compliant under test conditions that include the use of shielded cables between the storage system and a host. Shielded cables reduce the possibility of interference with radio, television, and other devices. If you use any cables that are not from SGI, make sure they are shielded. Telephone cables do not need to be shielded.

Electrostatic Discharge

SGI designs and tests its products to be immune to the effects of electrostatic discharge (ESD). ESD is a source of electromagnetic interference and can cause problems ranging from data errors and lockups to permanent component damage.

While operating the SGI TP900 storage system, it is important that you keep all the covers, doors, and dummy (filler) panels in place. The shielded cables that came with the product should be installed correctly.

Electromagnetic Emissions

This device complies with the Class B limits of Part 15 of the FCC Rules. Operation is subject to the following two conditions:

- This device may not cause harmful interference.
- This device must accept any interference received, including interference that may cause undesired operation.

Also, this device complies with Class B electromagnetic emissions limits of C.I.S.P.R. Publication 22, Limits and Methods of Measurement of Radio Interference Characteristics of Information Technology Equipment.

Index

A

airflow, 3, 15
anti-tamper lock, 8

B

bay numbering
 drive bay, 16
 enclosure, 16
 rear bay, 17
blank module, 15

C

cables, shielded, 54
Class B, 51-54
components, part numbers, 40
cooling module, 14
customer service, xiv

D

documentation
 IRIS InSight Library, xiv
 related, xiv
 Technical Publications Library, xiv
drive carrier module, 6
dummy carrier module, 15

E

electromagnetic emissions, 54
electrostatic discharge, 54
enclosure
 bay numbering, 16
 chassis, 2
 height, 2
Enclosure System Interface/Operators (ESI/Ops)
 panel, 4
ESI/Ops panel, 4

G

grounding checks, 21

H

humidity requirements, 48

I

input/output module, 12
I/O module, 12

L

LED status

drive carrier, 7
ESI/Ops panel, 4
power supply module, 11

M

manuals, related, xiv
model number, 51
module
 blank, 15
 cooling, 14
 drive carrier, 6
 dummy carrier, 15
 input/output, 12
 I/O, 12
 power supply, 10
 PSU, 10

N

numbering convention, modules, 16

P

part numbers, 40
physical specifications, 48
power requirements, 49
power supply module, 10
PSU, 10

R

regulatory information, 51-54

S

service, xiv
SGL, contacting, xiv
shielded cables, 54
slot numbering
 drive bay, 16
 enclosure, 16
 rear bay, 17
support, xiv

T

temperature requirements, 48

V

voltage, 49