



# SGI® UV™ 30 System User Guide

007-6419-001

---

## COPYRIGHT

© 2015 Silicon Graphics International Corp. All rights reserved; provided portions may be copyright in third parties, as indicated elsewhere herein. No permission is granted to copy, distribute, or create derivative works from the contents of this electronic documentation in any manner, in whole or in part, without the prior written permission of SGI.

---

## LIMITED RIGHTS LEGEND

The software described in this document is “commercial computer software” provided with restricted rights (except as to included open/free source) as specified in the FAR 52.227-19 and/or the DFAR 227.7202, or successive sections. Use beyond license provisions is a violation of worldwide intellectual property laws, treaties and conventions. This document is provided with limited rights as defined in 52.227-14.

The electronic (software) version of this document was developed at private expense; if acquired under an agreement with the USA government or any contractor thereto, it is acquired as “commercial computer software” subject to the provisions of its applicable license agreement, as specified in (a) 48 CFR 12.212 of the FAR; or, if acquired for Department of Defense units, (b) 48 CFR 227-7202 of the DoD FAR Supplement; or sections succeeding thereto. Contractor/manufacturer is SGI, 46600 Landing Parkway, Fremont, CA 94538.

---

## TRADEMARKS AND ATTRIBUTIONS

Silicon Graphics, SGI, and the SGI logo, and Supportfolio are trademarks or registered trademarks of Silicon Graphics International Corp. in the United States and/or other countries worldwide.

ASPEED is a registered trademark of ASPEED. InfiniBand is a registered trademark of the InfiniBand Trade Association. Intel, Itanium, and Xeon are trademarks or registered trademarks of Intel Corporation or its subsidiaries in the United States and other countries. ConnectX and Mellonox are registered trademarks of Mellonox Technologies, Ltd. Internet Explorer and MS-DOS are registered trademarks of Microsoft Corporation. Java and Java Virtual Machine are trademarks or registered trademarks of Sun Microsystems, Inc. Linux is a registered trademark of Linus Torvalds, used with permission by SGI. Matrox is a registered trademark of Matrox Electronic Systems Ltd. Novell and Novell Netware are registered trademarks of Novell Inc. PCIe and PCI-X are registered trademarks of PCI SIG. Red Hat and all Red Hat-based trademarks are trademarks or registered trademarks of Red Hat, Inc. in the United States and other countries. SUSE LINUX and the SUSE logo are registered trademarks of Novell, Inc. UNIX is a registered trademark in the United States and other countries, licensed exclusively through X/Open Company, Ltd.

All other trademarks mentioned herein are the property of their respective owners.

---

## Record of Revision

<b>Version</b>	<b>Description</b>
001	May 2015 Original printing.



---

# Contents

	<b>Record of Revision</b>	<b>iii</b>
	<b>About This Guide</b>	<b>xiii</b>
	Audience	xiii
	Chapter Descriptions	xiv
	Related Publications	xv
	Conventions	xv
	Product Support	xvi
	Reader Comments	xvi
<b>1</b>	<b>Introduction</b>	<b>1</b>
	Server Chassis Features	2
	Serverboard Features	4
	Additional Hardware Components	6
<b>2</b>	<b>System Safety</b>	<b>7</b>
	Electrical Safety Precautions	7
	General Safety Precautions	9
	ESD Precautions	10
	Operating Precautions	10
<b>3</b>	<b>Server Installation</b>	<b>11</b>
	Unpack the System	11
	Prepare for Setup	11
	Choose a Setup Location	12
	Warnings and Precautions	12
	Rack Precautions	12
	Server Precautions	13
	Rack Mounting Considerations	13
	Ambient Operating Temperature	13

	Reduced Airflow . . . . .	. 13
	Mechanical Loading . . . . .	. 13
	Circuit Overloading . . . . .	. 14
	Reliable Ground . . . . .	. 14
	Install the System into a Rack . . . . .	. 14
	Separate the Sections of the Rack Rails and Install Outer Rack Rails . . . . .	. 14
	Install the Inner Rails . . . . .	. 16
	Install the Server in a Rack . . . . .	. 18
	Check the Serverboard Setup. . . . .	. 20
	Removing the Chassis Cover . . . . .	. 20
	Checking the Components and Setup . . . . .	. 22
	Checking the Drive Bay Setup . . . . .	. 22
	Checking the Airflow . . . . .	. 22
	Providing Power . . . . .	. 22
<b>4</b>	<b>System Monitoring . . . . .</b>	<b>. 23</b>
	Control Panel Components . . . . .	. 24
	Drive Carrier LEDs . . . . .	. 27
	Power Supply LED . . . . .	. 28
<b>5</b>	<b>Chassis Maintenance . . . . .</b>	<b>. 29</b>
	Before You Start . . . . .	. 30
	Tools and Supplies Needed . . . . .	. 30
	Left-Right and User Position . . . . .	. 30
	Removing the Chassis Cover. . . . .	. 30
	Replacing a Power Supply . . . . .	. 32
	Replacing Disk Drives . . . . .	. 34
	Removing Carrier from Chassis and Drive from Carrier . . . . .	. 34
	Installing a Drive into a Carrier . . . . .	. 37
	Replacing System Fans . . . . .	. 38
<b>6</b>	<b>Troubleshooting. . . . .</b>	<b>. 41</b>
	If the System Does Not Power Up . . . . .	. 42
	System Powers Up But Will Not Boot . . . . .	. 42
	No Video After System Power Up . . . . .	. 43

	Memory Errors . . . . .	43
<b>A</b>	<b>Technical Specifications . . . . .</b>	<b>45</b>
<b>B</b>	<b>BIOS Error Codes . . . . .</b>	<b>49</b>





---

# Figures

Figure 1-1	The SGI UV 30 Server . . . . .	1
Figure 1-2	Front Chassis View . . . . .	3
Figure 1-3	Rear Chassis View . . . . .	3
Figure 1-4	Serverboard Block Diagram . . . . .	5
Figure 2-1	Installing the Onboard Battery . . . . .	8
Figure 2-2	Improper Use of Server Rack and Railing . . . . .	9
Figure 3-1	Separating and Installing the Rack Rails. . . . .	15
Figure 3-2	Installing the Inner Rails . . . . .	17
Figure 3-3	Installing the Server in a Rack . . . . .	19
Figure 3-4	Accessing the Inside of the Chassis . . . . .	21
Figure 4-1	Front Control Panel . . . . .	23
Figure 4-2	Control Panel Components . . . . .	24
Figure 5-1	Accessing the Inside of the Chassis . . . . .	31
Figure 5-2	Power Supply Release Tab . . . . .	32
Figure 5-3	Replacing a Power Supply . . . . .	33
Figure 5-4	Removing HDD Carrier from Chassis . . . . .	35
Figure 5-5	Removing Dummy Drive from Carrier . . . . .	36
Figure 5-6	Installing a Drive into a Carrier . . . . .	37
Figure 5-7	System Fans . . . . .	39



---

## Tables

Table 1-1	Server Chassis Features . . . . .	2
Table 1-2	Serverboard Features . . . . .	4
Table 4-1	Control Panel Components . . . . .	25
Table 4-2	Universal Information LED States . . . . .	25
Table 4-3	Drive Carrier LEDs . . . . .	27
Table 4-4	Power Supply LED States . . . . .	28
Table A-1	Temperature, Humidity, and Altitude Specifications . . . . .	45
Table A-2	Miscellaneous System Specifications . . . . .	46
Table B-1	BIOS Error Codes . . . . .	49



---

## About This Guide

This guide provides an overview of the installation, architecture, general operation, and descriptions of the major components in the SGI® UV™ 30 server. It also provides basic troubleshooting and maintenance information as well as important safety and regulatory specifications.

### Audience

This guide is written for owners, installers, system administrators, and users of SGI UV 30 computer systems. It is written with the assumption that the reader has a good working knowledge of computers and computer systems.

## Chapter Descriptions

The following topics are covered in this guide:

- Chapter 1, “Introduction”  
Provides an overview of SGI UV 30 server components.
- Chapter 2, “System Safety”  
Provides system safety information.
- Chapter 3, “Server Installation”  
Provides a quick setup checklist to get the server operational.
- Chapter 4, “System Monitoring”  
Describes how you monitor the overall status of the system as well as the activity and health of specific components.
- Chapter 5, “Chassis Maintenance”  
Describes how you replace fans, disk drives, and power supplies.
- Chapter 6, “Troubleshooting”  
Describes some basic steps to troubleshoot your system.
- [Appendix A, “Technical Specifications,”](#)  
Describes system component specifications.
- [Appendix B, “BIOS Error Codes,”](#)  
Provides BIOS error code information.

## Related Publications

The following SGI documents are relevant to the SGI UV 30 server:

- *SGI Foundation Software User Guide* (007-6410-xxx)
- SGI Performance Suite release notes
- SGI InfiniteStorage series documentation
- Man pages

You can obtain SGI documentation, release notes, or man pages in the following ways:

- Refer to the SGI Technical Publications Library at <http://docs.sgi.com>. Various formats are available. This library contains the most recent books and man pages.
- Refer to the SGI Supportfolio™ webpage for release notes and other documents whose access require a support contract. See “[Product Support](#)” on page xvi.

## Conventions

The following conventions are used throughout this document:

<b>Convention</b>	<b>Meaning</b>
Command	This fixed-space font denotes literal items such as commands, files, routines, path names, signals, messages, and programming language structures.
<i>variable</i>	The italic typeface denotes variable entries and words or concepts being defined. Italic typeface is also used for book titles.
<b>user input</b>	This bold fixed-space font denotes literal items that the user enters in interactive sessions. Output is shown in nonbold, fixed-space font.
[ ]	Brackets enclose optional portions of a command or directive line.
...	Ellipses indicate that a preceding element can be repeated.
man page(x)	Man page section identifiers appear in parentheses after man page names.
<b>GUI element</b>	This font denotes the names of graphical user interface (GUI) elements such as windows, screens, dialog boxes, menus, toolbars, icons, buttons, boxes, fields, and lists.

## Product Support

SGI provides a comprehensive product support and maintenance program for its products. SGI also offers services to implement and integrate Linux applications in your environment.

- Refer to <http://www.sgi.com/support/>
- If you are in North America, contact the Technical Assistance Center at +1 800 800 4SGI or contact your authorized service provider.
- If you are outside North America, contact the SGI subsidiary or authorized distributor in your country.

## Reader Comments

If you have comments about the technical accuracy, content, or organization of this document, contact SGI. Be sure to include the title and document number of the manual with your comments. (Online, the document number is located in the front matter of the manual. In printed manuals, the document number is located at the bottom of each page.)

You can contact SGI in any of the following ways:

- Send e-mail to the following address: [techpubs@sgi.com](mailto:techpubs@sgi.com)
- Contact your customer service representative and ask that an incident be filed in the SGI incident tracking system.

<http://www.sgi.com/support/supportcenters.html>

SGI values your comments and will respond to them promptly.



## Introduction

The SGI UV 30 server is a 2U rackmount server (see [Figure 1-1](#)). It has two main subsystems: the 2U server chassis and a quad-processor serverboard.

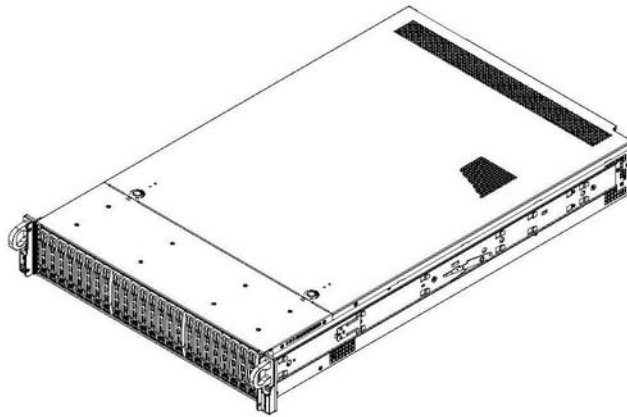

**Figure 1-1** The SGI UV 30 Server

This chapter describes the server using the following topics:

- “Server Chassis Features” on page 2
- “Serverboard Features” on page 4
- “Additional Hardware Components” on page 6

See [Appendix A](#), “Technical Specifications,” for the more details.

## Server Chassis Features

Table 1-1 describes the main features of the SGI UV 30 server chassis.

**Table 1-1** Server Chassis Features

Feature	Description
System power	The chassis features a redundant 2000W power supply consisting of two hot-pluggable, Titanium-level power modules (96% efficiency). The power redundancy allows the system to operate if one power supply module fails or is replaced.
Hard drives	The chassis is designed to support twenty-four 2.5" hot-swappable hard drive carriers. Twenty bays are SAS3 and, depending on the connections to the backplane, four hybrid bays support NVMe or SAS3.
PCI expansion slots	The system supports eleven PCIe® 3.0 expansion cards with four riser cards. These include seven cards with external ports and four internal cards. Two can be double-width GPUs.
Control panel	The front control panel, shown in <a href="#">Figure 1-2</a> , provides system monitoring and power control. LEDs indicate system power, HDD activity, and network activity, UID (unit identifier), overheat, and fan failure. A main power button and a reset button are also included.
Rear I/O ports	As shown in <a href="#">Figure 1-3</a> , the rear panel includes the following I/O ports: <ul style="list-style-type: none"> <li>– One VGA (monitor) port</li> <li>– One COM port</li> <li>– One dedicated IPMI LAN port</li> <li>– Two USB 3.0 ports</li> </ul>
Cooling system	The chassis has an innovative cooling design that features four 8-cm fans located in the middle section. Fan speed is determined by system temperature as monitored by IPMI. Each power supply module also includes a cooling fan.  The serverboard is fitted with an air shroud to maximize cooling.

Figure 1-2 shows the noteworthy components on the front of the server chassis.

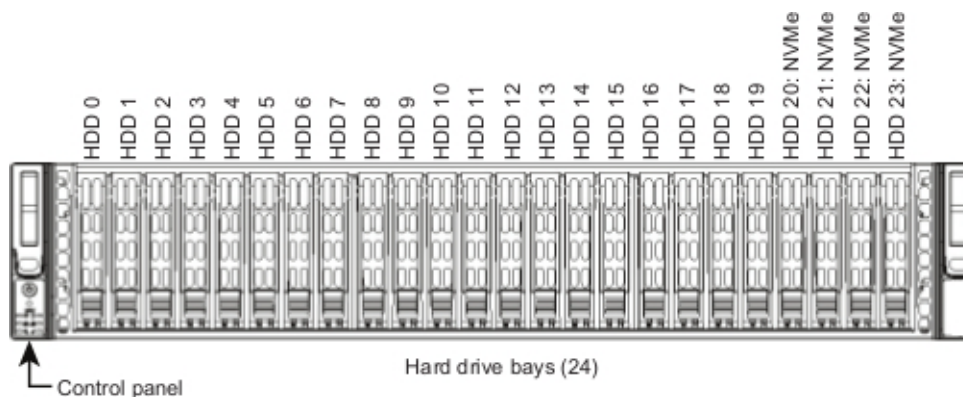

**Figure 1-2** Front Chassis View

Figure 1-3 shows the noteworthy components on the rear chassis panel.

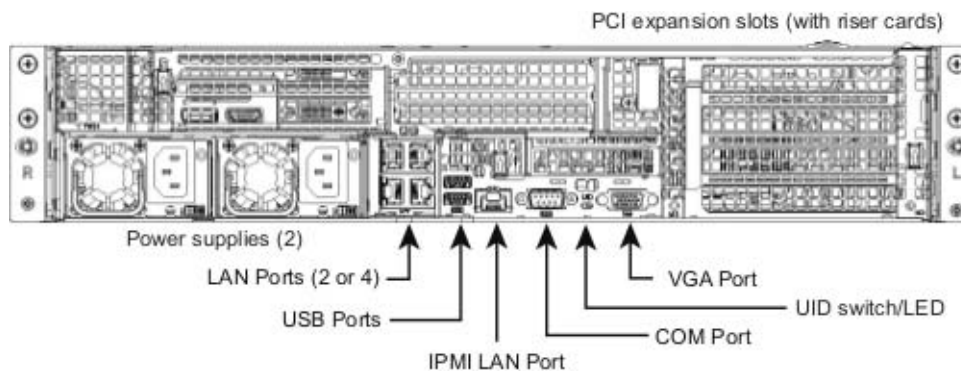

**Figure 1-3** Rear Chassis View

## Serverboard Features

At the heart of the SGI UV 30 server is a quad-processor serverboard based on the Intel® C612 chipset, designed to provide maximum performance. [Table 1-2](#) describes the major features of the serverboard.

**Table 1-2** Serverboard Features

Feature	Description
Processors	The serverboard supports up to four Intel® Xeon® E5-4600 v3 Series processors.
Memory	The serverboard has 48 memory slots that can support up to 3 TB of LRDIMM or 1.5 TB of RDIMM, DDR4-2133/1866/1600 memory.
Onboard serial ATA (SATA)	A SATA controller is integrated into the chipset to provide a ten-port SATA 3.0 subsystem. The I-SATA 4 and I-SATA 5 ports have built-in power pins to support SuperDOMs (SATA disk-on-module solution). RAID 0, 1, 5 and 10 are supported.
Graphics controller	There is integrated VGA with an ASPEED® AST2400 BMC.

[Figure 1-4](#) shows a block diagram of the serverboard.

---

**Note:** [Figure 1-4](#) is a general block diagram and may not represent the exact features on your serverboard. See [Table 1-2](#) for the actual specifications of your serverboard. This block diagram is intended for your reference only.

---

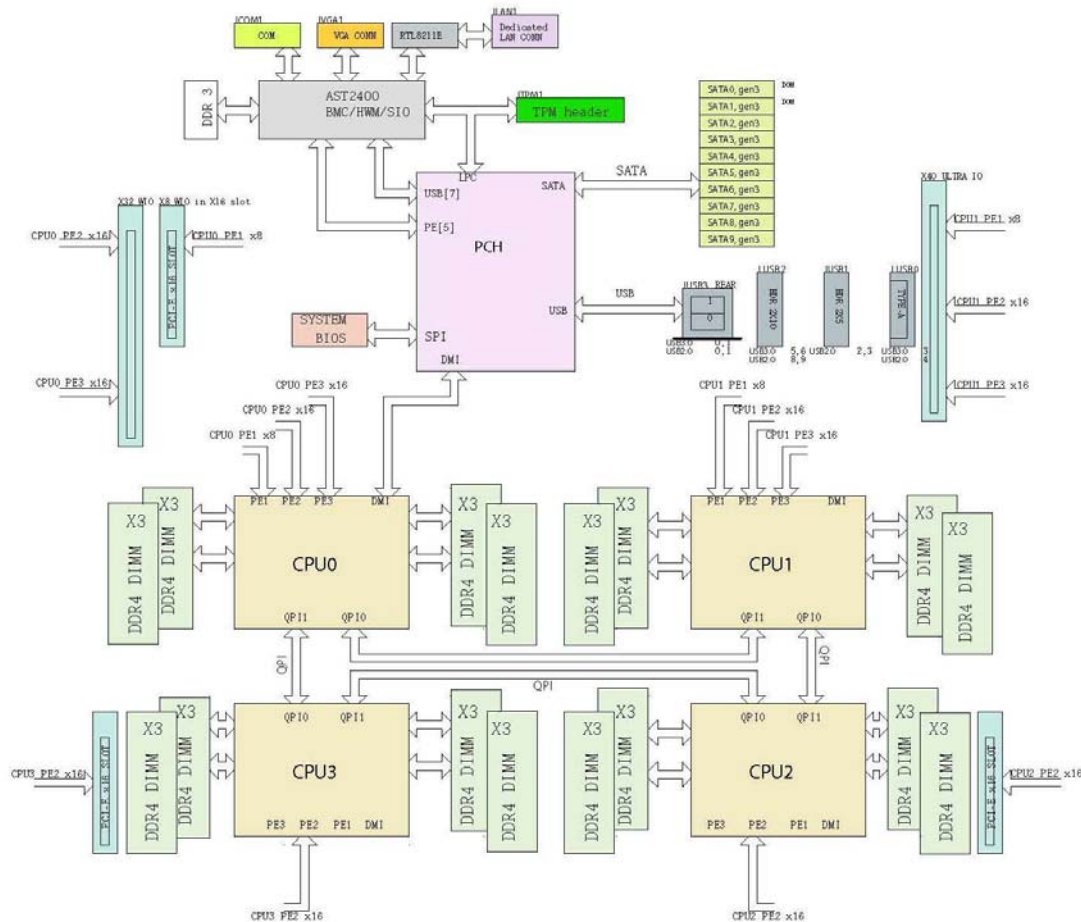

Figure 1-4 Serverboard Block Diagram

## Additional Hardware Components

In addition to the serverboard and chassis, the following hardware components have been included with the server:

- Four conventional riser cards
- One Ultra riser card
- A plastic air shroud
- Four 8-cm system cooling fans
- Four passive CPU heat sinks
- One SAS backplane
- 24 hot-swap 2.5" HDD trays
- One rack rail set

---

**Important:** SGI servers may sometimes require driver versions that are not included in the original operating system release. When required, SGI provides these drivers on the system disk (pre-installed in the factory) or via portable media or download. For more information on this topic, check with your sales or service representative.

---

## System Safety

This chapter describes basic safety precautions.

### Electrical Safety Precautions

Basic electrical safety precautions should be followed to protect yourself from harm and the SGI UV 30 system from damage, as follows:

- Be aware of the locations of the power on/off switch on the chassis as well as the room's emergency power-off switch, disconnection switch or electrical outlet. If an electrical accident occurs, you can then quickly remove power from the system.
- Do not work alone when working with high voltage components.
- Power should always be disconnected from the system when removing or installing main system components, such as memory modules and disk drives. When disconnecting power, you should first power down the operating system first and then unplug the power cords. The unit has more than one power supply cord. Disconnect two power supply cords before servicing to avoid electrical shock.
- When working around exposed electrical circuits, another person who is familiar with the power-off controls should be nearby to switch off the power if necessary.
- Use only one hand when working with powered-on electrical equipment. This is to avoid making a complete circuit, which will cause electrical shock. Use extreme caution when using metal tools, which can easily damage any electrical components or circuit boards they come into contact with.
- Do not use mats designed to decrease static electrical discharge as protection from electrical shock. Instead, use rubber mats that have been specifically designed as electrical insulators.
- The power supply power cords must include a grounding plug and must be plugged into grounded electrical outlets.

- Serverboard Battery



---

**Caution:** There is a danger of explosion if the onboard battery is installed upside down, which will reverse its polarities (see [Figure 2-1](#)). This battery must be replaced only with the same or an equivalent type recommended by the manufacturer. Dispose of used batteries according to the manufacturer's instructions.

---

- Mainboard replaceable soldered-in fuses: Self-resetting PTC (Positive Temperature Coefficient) fuses on the mainboard must be replaced by trained service technicians only. The new fuse must be the same or equivalent as the one replaced. Contact technical support for details and support.

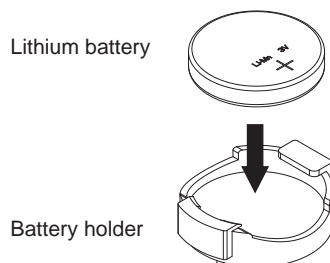

**Figure 2-1** Installing the Onboard Battery



## General Safety Precautions

Follow these rules to ensure general safety:

- Keep the area around the SGI UV 30 system clean and free of clutter.
- The system weighs approximately 52 lbs (23.6 kg.) when fully loaded. When lifting the system, two people at either end should lift slowly with their feet spread out to distribute the weight. Always keep your back straight and lift with your legs.
- Place the chassis top cover and any system components that have been removed away from the system or on a table so that they won't accidentally be stepped on.
- While working on the system, do not wear loose clothing such as neckties and unbuttoned shirt sleeves, which can come into contact with electrical circuits or be pulled into a cooling fan.
- Remove any jewelry or metal objects from your body, which are excellent metal conductors that can create short circuits and harm you if they come into contact with printed circuit boards or areas where power is present.
- After accessing the inside of the system, close the system back up and secure it to the rack unit with the retention screws after ensuring that all connections have been made.
- Do not make improper use of server rack or rail equipment, as noted [Figure 2-2](#).



**Figure 2-2** Improper Use of Server Rack and Railing

## ESD Precautions



---

**Caution:** Electrostatic discharge (ESD) is generated by two objects with different electrical charges coming into contact with each other. An electrical discharge is created to neutralize this difference. The discharge can damage electronic components and printed circuit boards.

---

The following measures are generally sufficient to neutralize this difference before contact is made to protect your equipment from ESD:

- Use a grounded wrist strap designed to prevent static discharge.
- Keep all components and printed circuit boards (PCBs) in their antistatic bags until ready for use.
- Touch a grounded metal object before removing the board from the antistatic bag.
- Do not let components or PCBs come into contact with your clothing, which may retain a charge even if you are wearing a wrist strap.
- Handle a board by its edges only; do not touch its components, peripheral chips, memory modules or contacts.
- When handling chips or modules, avoid touching their pins.
- Put the serverboard and peripherals back into their antistatic bags when not in use.
- For grounding purposes, make sure your computer chassis provides excellent conductivity between the power supply, the case, the mounting fasteners and the serverboard.

## Operating Precautions

The following are two noteworthy operating precautions:

- Ensure that the chassis cover is in place when the server is operating to ensure proper cooling. Out-of-warranty damage to the system can occur if this practice is not strictly followed.
- Please handle used batteries carefully. Do not damage the battery in any way. A damaged battery may release hazardous materials into the environment. Do not discard a used battery in the garbage or a public landfill. Please comply with the regulations set up by your local hazardous waste management agency to dispose of your used battery properly.

## Server Installation

This chapter provides a quick setup checklist to get the SGI UV 30 server operational.

### Unpack the System

Inspect the shipping container used for the server and note if it was damaged in any way. If the server shows damage, file a damage claim with the carrier who delivered it.

Decide on a suitable location for the rack that supports the weight, power requirements, and environmental requirements of the server. It should be situated in a clean, dust-free environment that is well ventilated. Avoid areas where heat, electrical noise, and electromagnetic fields are generated. Place the server rack near a grounded power outlet. Refer to [“Warnings and Precautions”](#) on page 12.

### Prepare for Setup

The shipping container should include two sets of rail assemblies, two rail mounting brackets and the mounting screws that you will use to install the system into a rack.

Read this section in its entirety before you begin the installation procedure.

## Choose a Setup Location

Follow these guidelines:



---

**Caution:** The equipment is intended for installation only in a restricted access location.

---

- This product is not suitable for use with visual display work place devices according to Clause 2 of the *German Ordinance for Work with Visual Display Units* document.
- Leave enough clearance in front of the rack to enable you to open the front door completely (~25 inches) and approximately 30 inches of clearance in the back of the rack to allow for sufficient airflow and ease in servicing.

## Warnings and Precautions

### Rack Precautions



---

**Warning:** Failure to follow the following guidelines can result in serious injury or damage to the equipment.

---

- The SGI UV 30 server weighs 52 lbs (23.6 kg). Always use proper lifting techniques when you move the server. Always get the assistance of another qualified person when you install the server in a location above your shoulders.
- Extend the leveling jacks on the bottom of the rack to the floor with the full weight of the rack resting on them.
- Attach stabilizers to the rack in single rack installations.
- Couple racks together in multiple rack installations.
- Be sure the rack is stable before extending a component from the rack.
- Extend only one component at a time. Extending two or more components simultaneously may cause the rack to tip over.

## Server Precautions

- Review the electrical and general safety precautions in [Chapter 2, “System Safety.”](#)
- Determine the placement of each component in the rack before you install the rails.
- Install the heaviest server components in the bottom of the rack first, and then work up.
- Use a regulating uninterruptible power supply (UPS) to protect the server from power surges and voltage spikes and to keep your system operating in case of a power failure.
- Allow the hot-pluggable SATA drives and power supply modules to cool before touching them.
- Always keep the rack’s front door and all panels and components on the servers closed when not servicing to maintain proper cooling.

## Rack Mounting Considerations

### Ambient Operating Temperature

If installed in a closed or multi-unit rack assembly, the ambient operating temperature of the rack environment may be greater than the ambient temperature of the room. Therefore, consideration should be given to installing the equipment in an environment compatible with the manufacturer’s maximum rated ambient temperature (35° C or 95° F).

---

**Note:** Certain processor or coprocessor configurations may require more stringent temperature constraints. If this is true for your system, SGI will so notify you.

---

### Reduced Airflow

Equipment should be mounted into a rack so that the amount of airflow required for safe operation is not compromised.

### Mechanical Loading

Equipment should be mounted into a rack so that a hazardous condition does not arise due to uneven mechanical loading.

## Circuit Overloading

Consideration should be given to the connection of the equipment to the power supply circuitry and the effect that any possible overloading of circuits might have on overcurrent protection and power supply wiring. Appropriate consideration of equipment nameplate ratings should be used when addressing this concern.

## Reliable Ground

A reliable ground must be maintained at all times. To ensure this, the rack itself should be grounded. Particular attention should be given to power supply connections other than the direct connections to the branch circuit (for example, the use of power strips, and so on).

## Install the System into a Rack

This section provides information on installing the server into a rack. If the system has already been mounted into a rack, refer to “[Check the Serverboard Setup](#)” on page 20. There are a variety of rack units on the market, which may mean the assembly procedure will differ slightly. You should also refer to the installation instructions that came with the rack unit you are using.

---

**Note:** This rail will fit a rack between 26.5" and 36.4" deep.

---

## Separate the Sections of the Rack Rails and Install Outer Rack Rails

The chassis package includes two rail assemblies in the rack mounting kit. Each assembly consists of two sections: an inner fixed chassis rail that secures directly to the server chassis and an outer fixed rack rail that secures directly to the rack itself.

Steps 1–4 describe how to separate the inner and outer rails:

1. Locate the rail assembly in the chassis packaging as shown in [Figure 3-1](#).
2. Extend the rail assembly by pulling it outward.
3. Press the quick-release tab.
4. Separate the inner rail from the outer rail assembly as shown in [Figure 3-1](#).

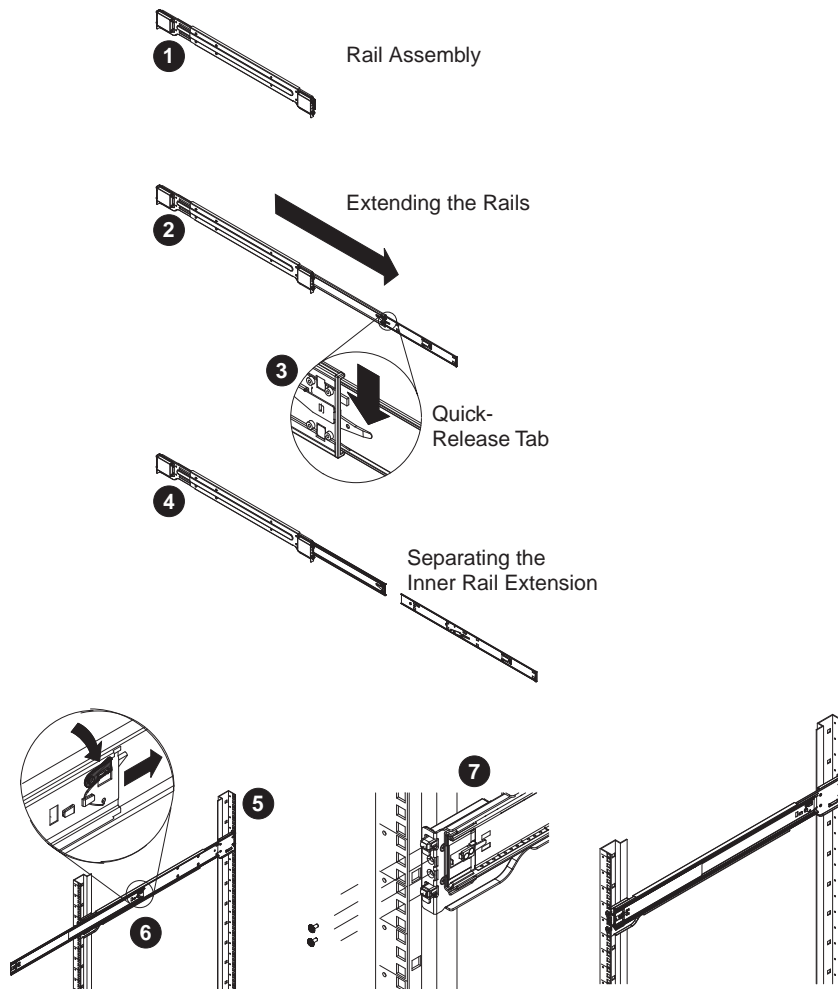

**Figure 3-1** Separating and Installing the Rack Rails

Outer rails attach to the rack and hold the chassis in place. The outer rails for the chassis extend between 30 inches and 33 inches.

Steps 5–8 describe how to install the outer rails to the rack (see [Figure 3-1](#)):

5. Secure the back end of the outer rail to the rack, using the screws provided.

6. Press the button where the two outer rails are joined to retract the smaller outer rail.
7. Hang the hooks of the rails onto the rack holes and if desired, use screws to secure the front of the outer rail onto the rack.
8. Repeat steps 5-7 for the remaining outer rail.

## Install the Inner Rails

The inner rails are different for the left side and right side of the chassis and are so labeled.

Perform the following steps to install an inner rail as illustrated in [Figure 3-2](#):

1. Place the inner rail on the appropriate side of the chassis.  
Align the hooks of the chassis with the rail holes. Make sure the rail faces outward.
2. To secure the rail to the chassis, slide the rail toward the front of the chassis until the quick-release bracket snaps into place.
3. Optionally, secure the rail to the chassis with screws as illustrated.
4. Repeat the prior steps for the other inner rail.



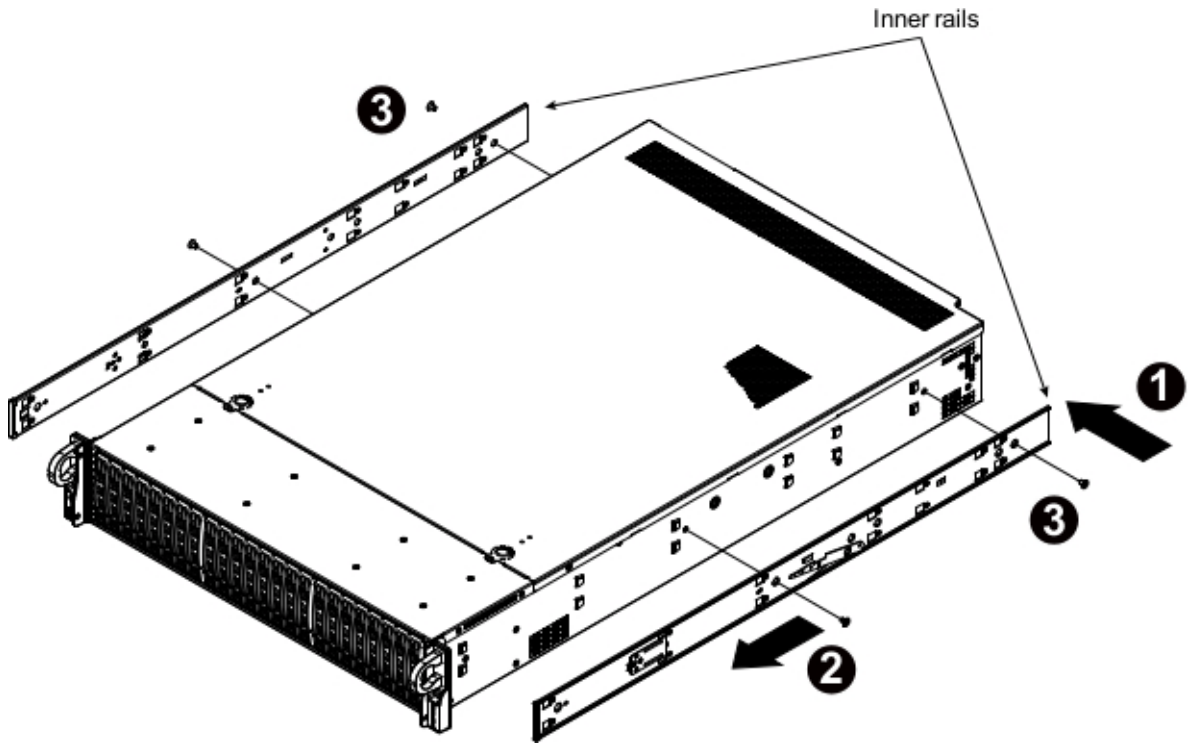

Figure 3-2 Installing the Inner Rails

## Install the Server in a Rack



---

**Warning:** The SGI UV 30 server weighs 52 lbs (23.6 kg). Always use proper lifting techniques when you move the server. Always get the assistance of another qualified person when you install the sever in a location above your shoulders. Failure to do so may result in serious personal injury or damage to the equipment.

---

You should now have rails attached to both the server chassis and the rack unit. The next step is to install the server into the rack (refer to [Figure 3-3](#)).

1. Extend the outer rails as shown in [Figure 3-3](#).
2. Align the inner rails of the chassis with the outer rails on the rack.
3. Slide the inner rails into the outer rails, keeping the pressure even on both sides. When the chassis has been pushed completely into the rack, it should click into the locked position.
4. Optional screws may be used to secure the to hold the front of the chassis to the rack.

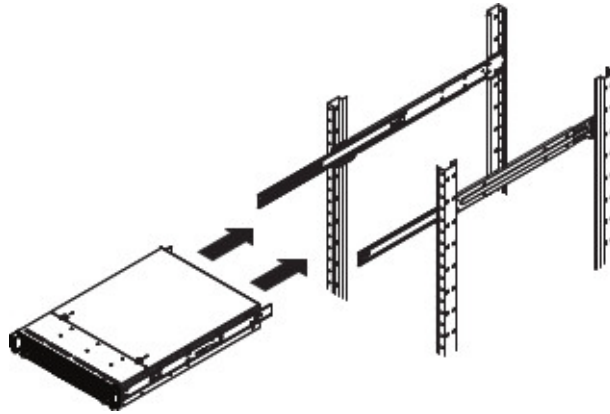

**Figure 3-3** Installing the Server in a Rack

---

**Note:** The figure above is for illustration purposes. Always install servers to the rack in a bottom-to-top fashion.

---

## Check the Serverboard Setup

After you install the server in the rack, you will need to open the unit to make sure the serverboard is properly installed and all the connections have been made. Before operating the server for the first time, it is important to remove any protective film covering the top of the chassis. The removal of this film allows for proper ventilation and cooling.

## Removing the Chassis Cover

Use the following procedure for removing the chassis cover as illustrated in [Figure 3-4](#).

---

**Note:** Ensure that the system is not turned on or connected to AC power.

---

1. If the server is rack-mounted, grasp the two front handles and pull the server straight out until it locks.  

You will hear a click when it locks. To remove the system from the rack completely, depress the locking tabs on the chassis rails (push the right-side tab down and the left-side tab up) to continue to pull the system out past the locked position.
2. If the two optional screws are securing the cover to the chassis, remove them, one from each side of the cover.
3. Press both release tabs at the same time to unlock the cover and slide the cover to the rear.
4. Lift the cover from the chassis.

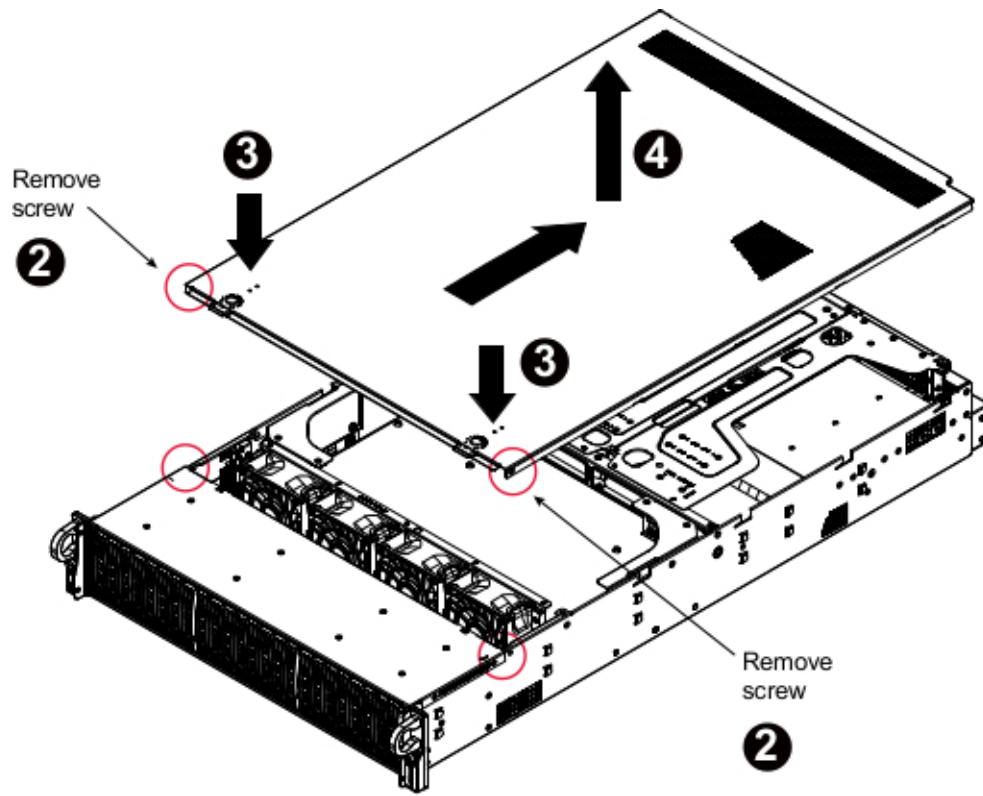

**Figure 3-4** Accessing the Inside of the Chassis

## Checking the Components and Setup

You may have two or four processors already installed in your serverboard. Ensure that the serverboard is populated per your order.

Your server system comes with system memory already installed. Make sure all DIMMs are fully seated in their slots.

Ensure that all power and data cables are properly connected and not blocking the chassis airflow. Also, make sure that no cables are positioned in front of the fans.

## Checking the Drive Bay Setup

Ensure that the peripheral drives and the disk drives have been properly installed and all connections have been made.

Do not operate the server without drives or drive trays in the drive bays. Depending upon your system's configuration, your system may have one or more drives already installed. All drives are accessible from the front of the server. If you need to install hard drives, see [“Replacing Disk Drives” on page 34](#). Use only recommended server parts.

## Checking the Airflow

Airflow is provided by four 8-cm chassis cooling fans. The system component layout was carefully designed to direct sufficient cooling airflow to the components that generate the most heat.

Ensure that all power and data cables have been routed in such a way that they do not block the airflow generated by the fans.

## Providing Power

Plug the power cord(s) from the power supply unit(s) into a high-quality power strip that offers protection from electrical noise and power surges. It is recommended that you use an uninterruptible power supply (UPS).

Depress the power button on the control panel, located on the front of the chassis. See [“Control Panel Components” on page 24](#).

## System Monitoring

There are several buttons and LEDs on the control panel, drive carriers, and power supplies to keep you constantly informed of the overall status of the system. As shown in [Figure 4-1](#), the control panel is on the left handle of the chassis.

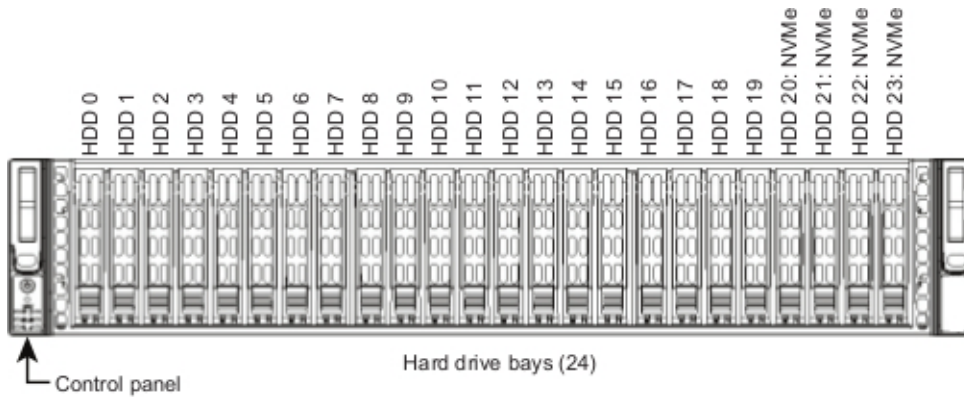
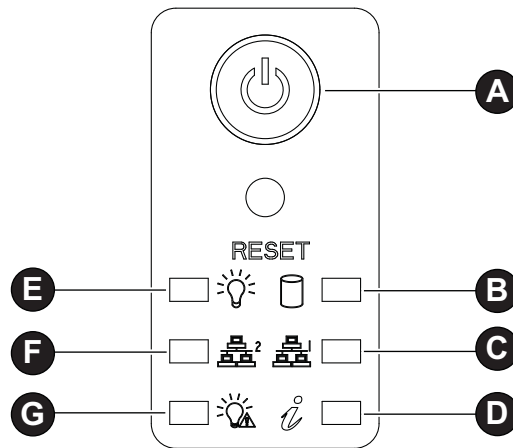

**Figure 4-1** Front Control Panel

This chapter describes the functions of the buttons and LEDs and the appropriate responses you may need to take.

## Control Panel Components

Figure 4-2 shows the components of the control panel.



**Figure 4-2** Control Panel Components



Table 4-1 describes the functions of the components.

**Table 4-1** Control Panel Components

Component	Description
<b>A</b>	The main power button is used to apply or remove power from the power supply to the server. Turning off system power with this button removes the main power but keeps standby power supplied to the system. Therefore, you must unplug the server before servicing.
<b>RESET</b>	Depressing this button resets all registers and reboots the operating system.
<b>B</b>	When flashing, this LED indicates HDD activity.
<b>C, F</b>	When flashing, these LEDs indicates network activity on the GLAN1 and GLAN2, respectively.
<b>D</b>	This is the Universal Information LED. It can indicate an overheat condition, fan failure, power failure, or the UID button activation. See Table 4-2. This LED will remain solid red or continue to flash as long as the temperature is too high or a fan does not function properly.
<b>E</b>	When illuminated, this LED indicates that power is being supplied by the power supply units. This LED should be illuminated when the system is operating.
<b>G</b>	When illuminated, this LED indicates a power failure.

**Table 4-2** Universal Information LED States

LED State	Condition
Blinking red (1 Hz)	Fan failure
Blinking red (0.25 Hz)	Power failure. Check the power supplies.

**Table 4-2** Universal Information LED States **(continued)**

LED State	Condition
Solid red	An overheat condition has occurred. For an overheat condition, consider the following: <ul style="list-style-type: none"><li>- Ensure that the ambient room temperature is not too warm.</li><li>- Check the routing of cables and make sure all fans are present and operating.</li><li>- Ensure that the chassis cover and air shrouds are installed.</li><li>- Verify that the heatsinks are installed properly.</li></ul>
Solid blue	Local UID button depressed. Use this function to locate the server in a rack.
Blinking blue	IPMI-activated UID. Use this function to identify the server from a remote location.

## Drive Carrier LEDs

Each hard drive carrier has two LEDs. [Table 4-3](#) describes the functions of the two LEDs.

**Table 4-3** Drive Carrier LEDs

LED	Color	Blinking Pattern	Behavior for Device
Activity LED	Blue	Solid on	SAS/NVMe drive installed
	Blue	Blinking	I/O activity
Status LED	Red	Solid on	Failure of drive with RSTe support
	Red	Blinking at 1 Hz	Rebuild drive with RSTe support
	Red	Blinking with two blinks and one stop at 1 Hz	Hot spare for drive with RSTe support
	Red	On for five seconds, then off	Power on for drive with RSTe support
	Red	Blinking at 4 Hz	Identify drive with RSTe support
	Green	Solid on	Safe to remove NVMe device
	Amber	Blinking at 1 Hz	Attention state. Do not remove NVMe device.

Refer to “[Replacing Disk Drives](#)” on page 34 for instructions on replacing failed drives.

## Power Supply LED

There is a single bi-color LED (green/amber) to indicate the power supply status. [Table 4-4](#) describes the different states of the LED.

**Table 4-4** Power Supply LED States

LED State	Power Supply (PS) State
Off	No AC power to any PS.
Green	Output on and Ok.
Green, 1Hz blink	AC present (only 12VSB on). PS off or PS in cold redundant state. <b>Note:</b> This is the normal state for a redundant PS.
Green, 2Hz blink	PS firmware updating.
Amber	<ul style="list-style-type: none"><li>– PS critical event causing a shutdown/failure (OCP, OVP, fan failure)</li><li>– AC cord unplugged or AC power lost. A second power supply in parallel still has AC input power.</li></ul>
Amber, 1Hz blink	PS warning events where the power supply continues to operate (high temperature, high power, high current, slow fan). The system power supply temperature has reached 63°C. The system will automatically power-down when the power supply temperature reaches 70°C and restart when the power supply temperature goes below 60°C.

## Chassis Maintenance

For warranty and safety considerations, SGI designates the following chassis components as customer-replaceable units:

- Power supplies
- Fans
- Disk drives

The disk drives and power supplies are hot-swappable; that is, you can replace them without powering down the server. As a safety precaution, replacing the fans requires a system power-down. A trained service technician should install and replace all other components.

This chapter describes the following chassis maintenance activities:

- “Removing the Chassis Cover” on page 30
- “Replacing a Power Supply” on page 32
- “Replacing Disk Drives” on page 34
- “Replacing System Fans” on page 38

## Before You Start



---

**Warning:** Review the warnings and precautions listed in this manual before setting up or servicing this chassis. These include the items described in [Chapter 2, “System Safety.”](#)

---

## Tools and Supplies Needed

- Phillips (cross head) screwdriver
- Anti-static wrist strap and conductive foam pad (recommended)

## Left-Right and User Position

All references to left, right, front, top, and bottom assume you are facing the front of the chassis as it would be positioned for normal operation.

## Removing the Chassis Cover

---

**Caution:** Except for short periods of time, do not operate the server without the cover in place. The chassis cover must be in place to allow proper airflow and prevent overheating.

---

Use the following procedure for removing the chassis cover as illustrated in [Figure 5-1](#).

---

**Note:** Ensure that the system is not turned on or connected to AC power.

---

1. If the server is rack-mounted, grasp the two front handles and pull the server straight out until it locks.  
  
You will hear a click when it locks. To remove the system from the rack completely, depress the locking tabs on the chassis rails (push the right-side tab down and the left-side tab up) to continue to pull the system out past the locked position.
2. If the two optional screws are securing the cover to the chassis, remove them, one from each side of the cover.

3. Press both release tabs at the same time to unlock the cover and slide the cover to the rear.
4. Lift the cover from the chassis.

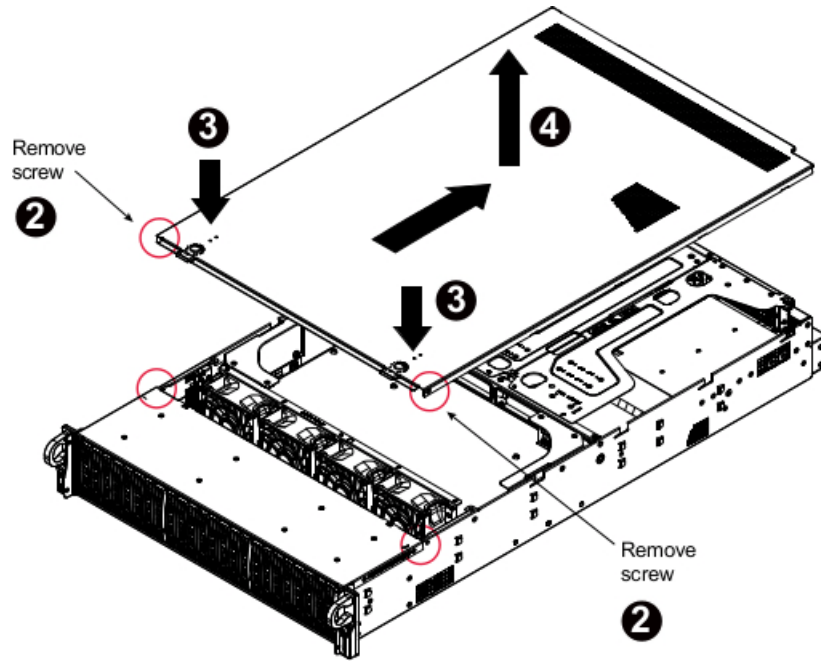

**Figure 5-1** Accessing the Inside of the Chassis

## Replacing a Power Supply

The server chassis includes a redundant, hot-pluggable 2000W power supply, consisting of two power modules. They have an auto-switching capability, which enables them to automatically sense and operate at a 100V–240V input voltage.

If either of the two power supply modules fail, the other module will take the full load and allow the system to continue operation without interruption. The power fail LED will illuminate and remain on until the failed unit has been replaced.

Use the following steps to replace a power supply.



---

**Caution:** Unplug the AC power cord from the failed power supply module to reduce the risk of injury from electric shock.

---

1. Pull out the power supply handle and press the retaining clip on the right side of the power supply, as illustrated in [Figure 5-2](#).
2. While pressing the retaining clip, pull the power supply out. See [Figure 5-3](#).
3. Push the new power supply module into the power bay until you hear a click.
4. Plug the AC power cord back into the module.

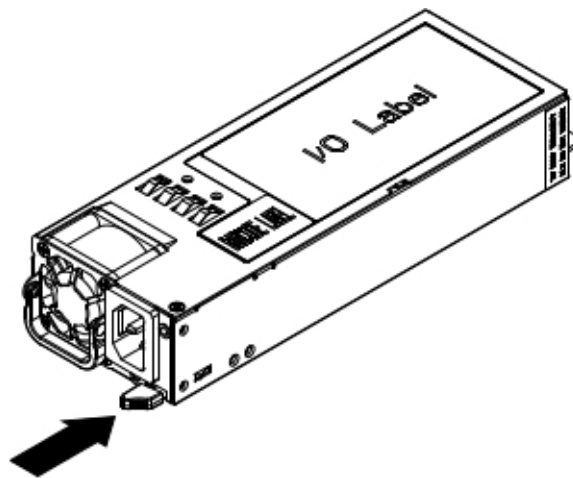

**Figure 5-2** Power Supply Release Tab



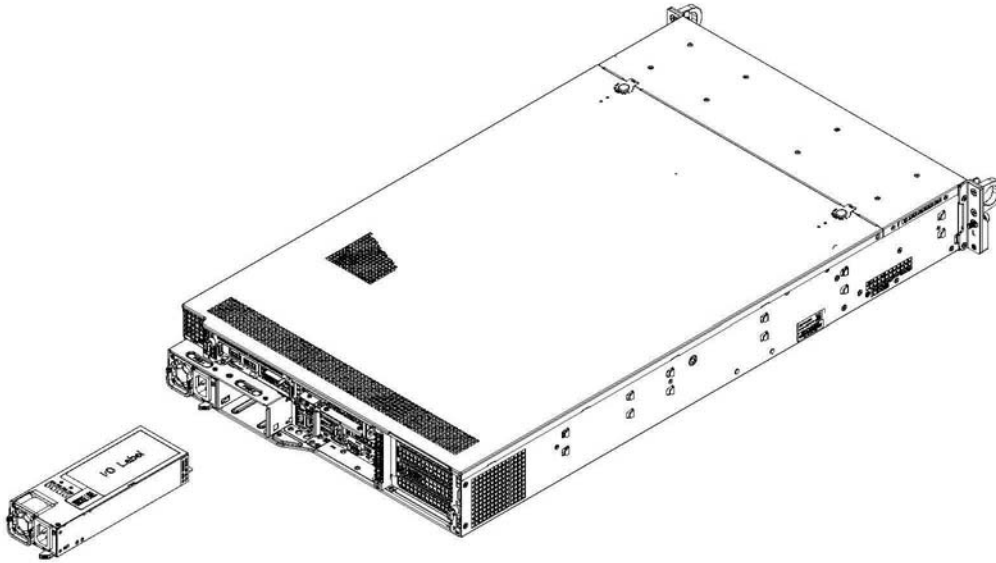

**Figure 5-3** Replacing a Power Supply

## Replacing Disk Drives

---

**Caution:** Except for short periods of time while swapping hard drives, do not operate the server with the hard drive slots empty.

---

The server has twenty-four hot-swappable 2.5" drive bays. The hard drives are mounted in drive carriers to simplify their installation and removal from the chassis. System power may remain on when removing carriers with drives installed. These carriers also help promote proper airflow for the drive bays. For this reason, even empty carriers without drives installed must remain in the chassis.

## Removing Carrier from Chassis and Drive from Carrier

Use the following procedure to remove the HDD carrier from the chassis and the drive from the carrier.

1. Press the release button on the drive carrier.  
This extends the drive carrier handle. See [Figure 5-4](#).
2. Using the handle, pull the drive carrier out of the chassis.
3. Remove the disk drive or dummy drive from the carrier.  
See [Figure 5-5](#).

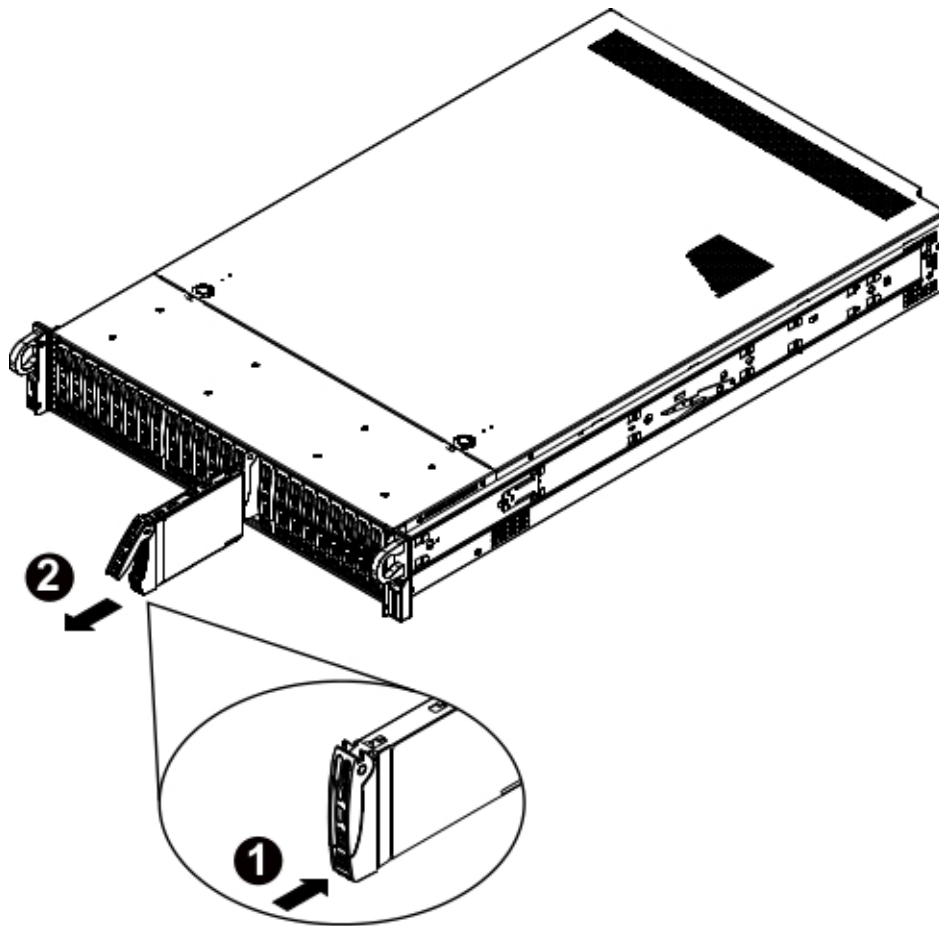

**Figure 5-4** Removing HDD Carrier from Chassis

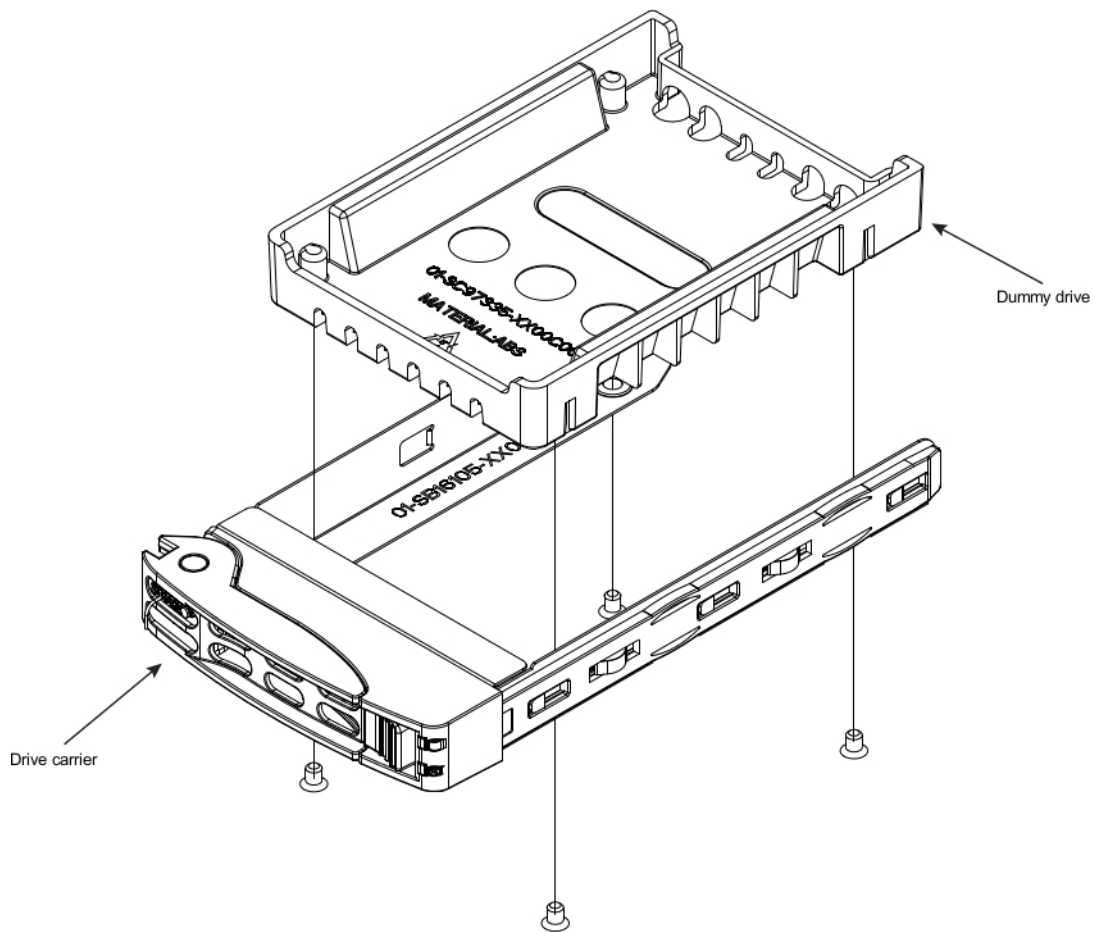

**Figure 5-5** Removing Dummy Drive from Carrier

## Installing a Drive into a Carrier

Use the following procedure to install a drive into a carrier.

1. Install a new drive into the carrier with the printed circuit board side facing down so that the mounting holes in the drive align with those in the carrier.

See [Figure 5-6](#).

2. Secure the hard drive into the carrier with four screws.
3. Use the open handle to replace the drive carrier into the chassis.
4. Gently close the drive carrier handle to secure the drive and carrier into the chassis drive bay.

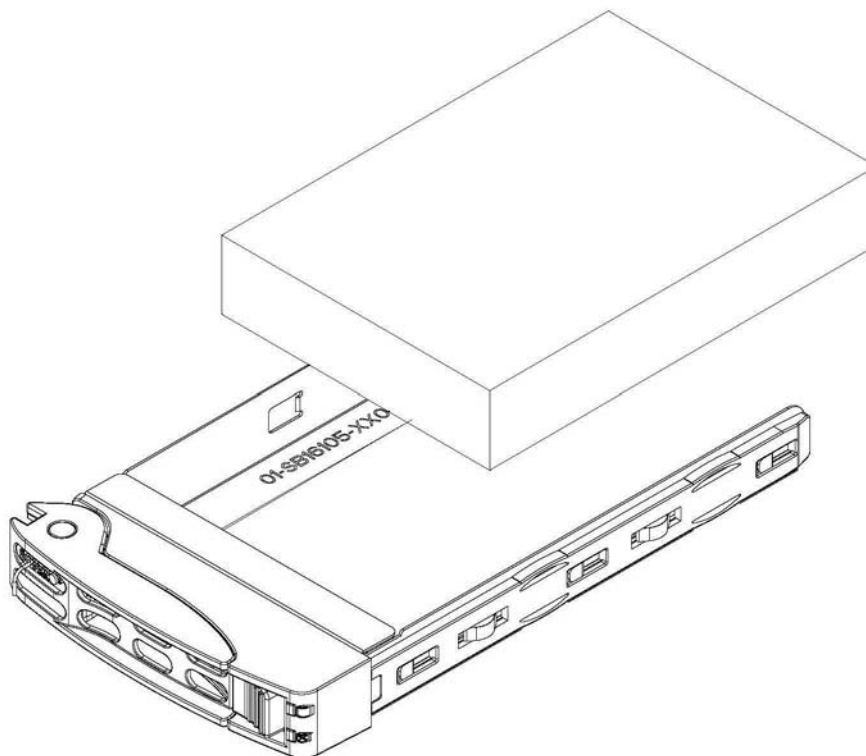

**Figure 5-6** Installing a Drive into a Carrier

## Replacing System Fans

Fan speed is controlled by system temperature via IPMI. If a fan fails, the remaining fan will ramp up to full speed and the overheat/fan fail LED on the control panel will turn on. Replace any failed fan at your earliest convenience with the same type and model. The system can continue to run with a failed fan.

Use the following procedure to replace a failed fan:

1. Remove the top chassis cover while the system is still running to determine which of the fans has failed.  
See [“Removing the Chassis Cover” on page 30](#).
2. Power down the system.
3. Remove the power cord(s) as a safety precaution.
4. Unplug the fan wiring from the serverboard and remove the failed fan.
5. Press the fan release tab to lift the failed fan from the chassis and pull it completely from the chassis.

See [Figure 5-7](#).

6. Place the new fan into the vacant space in the housing while making sure the arrows on the top of the fan (indicating air direction) point in the same direction as the arrows on the other fans.
7. Power up the system and ensure that the fan is working properly before replacing the chassis cover.

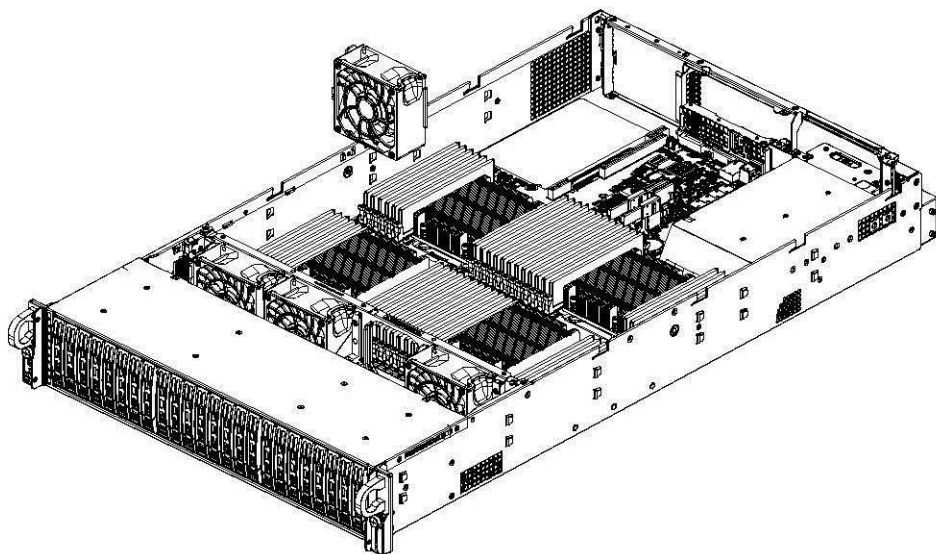

**Figure 5-7** System Fans





## Troubleshooting

This chapter describes troubleshooting for the problems listed below. [Chapter 4](#) describes use of the control panel to monitor the overall system status and the status of specific components. [Chapter 5](#), “Chassis Maintenance” describes how to replace defective components.

- “If the System Does Not Power Up” on page 42
- “System Powers Up But Will Not Boot” on page 42
- “No Video After System Power Up” on page 43
- “Memory Errors” on page 43

If you follow all of the prescribed procedures and still need assistance, check with your authorized support organization.

## If the System Does Not Power Up

If the system will not power up when the front power button is pushed, use the following checklist to identify common sources for the problem:

- Make sure that both ends of each system power cable are firmly connected to the power supply and the corresponding power source(s) or power distribution unit (PDU).
- Check that the LED on each power supply is properly lit. The power supply has one status LED located on the left side of the front of the power supply. The status LED has three states as follows:
  - Dark or off—Indicates no AC power present.
  - Yellow—AC power is present. The server is not turned on (no DC power).
  - Flashes slowly (about four seconds on/off)—Power supply has failed.
  - Green—AC power is present and the server is turned on (DC power present).
- Open the system cover, remove the air shroud, and check to make sure that no obvious short circuits exist between the serverboard and chassis.

If you must replace the power supply, refer to [“Replacing a Power Supply”](#) on page 32.

## System Powers Up But Will Not Boot

If the system powers up but will not boot the operating system, check the following:

- Check the system order document(s) - the server may have been ordered with no operating system. If so, check with your system administrator for OS loading information.
- Check the system disk for drive activity and confirm that it is firmly seated in the disk bay. A red light on the front of the disk indicates a functional error. Check with your service provider or local system administrator.

## No Video After System Power Up

If the system powers up and appears to be booting normally but no video is present, try the following basic solutions:

- Confirm your monitor is plugged in and switched on.
- Check all video cables and ensure they are properly connected.
- If using an optional PCIe video card check the back of the card for LED activity or a fault indicator. Try opening the system, reseating the PCI card, and rebooting.

If you cannot get a video signal after trying basic solutions contact your support provider.

## Memory Errors

If your system experiences memory related errors, try these basic troubleshooting steps to resolve or better identify the problem:

- Confirm that the power supply LED is not indicating an error.
- Shut the system down, remove the covers over the serverboard and make sure that all the DIMM modules are properly and fully installed.
- You should be using registered ECC DDR4 memory. Also, it is recommended that you use the same memory type and speed for all DIMMs in the system.
- Check for bad DIMM modules or slots by swapping modules between slots and noting the results.

Contact your administrator or support provider if the memory errors continue.



## Technical Specifications

Table A-1 lists allowable ranges for temperature, humidity, and altitude for the SGI UV 30 server.

**Table A-1** Temperature, Humidity, and Altitude Specifications

Attribute	Specification	Rate of Change Constraints
<b>While Product Operating</b>		
Temperature	– Up to 1500m (5000ft) +5°C (41°F) to +35°C <sup>1</sup> (95°F) – 1525m (5000ft) to 3050m (10,000ft) Reduce max temperature (35°C <sup>1</sup> ) by 1°C per 305m (1000ft) of altitude above 1525m (5000ft).	Maximum: 10°C/hour (18°F/hour)
Humidity	20% to 80% Non-condensing	Maximum: 10% relative humidity/hour
Altitude	3050m (10,000ft)	
<b>While Product Power Off</b>		
Temperature	+5°C (41°F) to +45°C (113°F)	Maximum: 20°C/hour (36°F/hour)
Humidity	8% to 80% Non-condensing	
Altitude	3050m (10,000ft)	
<b>While Product Packaged for Shipping</b>		
Temperature	-40°C (-40°F) to +60°C (140°F)	Maximum: 20°C/hour (36°F/hour)
Humidity	8% to 80% Non-condensing	
Altitude	12,200m (40,000ft)	
<b>Notes:</b> 1. Certain processor or coprocessor configurations may require more stringent temperature constraints—for example, a maximum ambient temperature of 25°C or 30°C. If this is true for your system, SGI will so notify you.		

Table A-2 lists other key specifications for the server.

**Table A-2** Miscellaneous System Specifications

Attribute	Specification
Processors	<ul style="list-style-type: none"> <li>– Up to four Intel Xeon E5-4600 v3 Series processors</li> <li>– LGA2011 sockets (Socket R3)</li> </ul>
Chipset	Intel PCH C612 chipset
BIOS	16 MB AMI® SPI Flash EEPROM
Memory	3 TB of LRDIMM (or 1.5 TB RDIMM) DDR4 2133/1866/1600 memory
SATA Controller	Intel chipset-based controller provides support for 10 SATA 3.0 ports (RAID 0, 1, 5, and 10 supported)
Drive Bays	<ul style="list-style-type: none"> <li>– 24 hot-swap drive bays to house standard 2.5” drives</li> <li>– One 5.25” drive bay</li> </ul>
PCI Expansion Slots	<ul style="list-style-type: none"> <li>– Two PCIe® 3.0 x16 cards (full-height, full-length)</li> <li>– Two PCIe 3.0 x8 cards (full-height, full-length)</li> <li>– Two PCIe 3.0 x8 cards (full-height, half-length)</li> <li>– One PCIe 3.0 x8 card (low-profile, half-length)</li> <li>– Four PCIe 3.0 x8 cards (low-profile, internal)</li> </ul>
Onboard Graphics	ASPEED® AST2400 BMC chip
Chassis	2U standard-depth rackmount Dimensions: (WxHxD) 19 x 3.2 x 35.9 in. (48.3 x 8.2 x 91.2 cm) (Includes handles and power supply extension.)
Serverboard	Dimensions: (LxW) 20 x 16.8 in. (50.8 x 42.7 cm)
Weight	Gross: 52 lbs (23.6 kg)
System Cooling	Four 8-cm high-performance fans
System Input Requirements	<ul style="list-style-type: none"> <li>– AC Input Voltage: 100 – 240V AC auto-range</li> <li>– Rated Input Current: 13 – 4A max</li> <li>– Rated Input Frequency: 50 – 60 Hz</li> </ul>

**Table A-2** Miscellaneous System Specifications **(continued)**

Attribute	Specification
Power Supply	– 2 x Hot-pluggable 1U PSU 2000W – Rated Output Power: 2000W redundant power – Rated Output Voltages: +12V (62.5A at 100–127VAC, 83A at 200–240VAC), +12Vsb (2.1A)
Regulatory Compliance	Electromagnetic Emissions: FCC Class A, EN 55022 Class A, EN 61000-3-2/-3-3, CISPR 22 Class A Electromagnetic Immunity: EN 55024/CISPR 24, (EN 61000-4-2, EN 61000-4-3, EN 61000-4-4, EN 61000-4-5, EN 61000-4-6, EN 61000-4-8, EN 61000-4-11) Safety: CSA/EN/IEC/UL 60950-1 Compliant, UL or CSA Listed (USA and Canada), CE Marking (Europe) California Best Management Practices Regulations for Perchlorate Materials: “This Perchlorate warning applies only to products containing CR (Manganese Dioxide) Lithium coin cells. Special handling for perchlorate material may apply. See the webpage <a href="http://www.dtsc.ca.gov/hazardouswaste/perchlorate">www.dtsc.ca.gov/hazardouswaste/perchlorate</a> .”





---

## BIOS Error Codes

During Power-On Self-Test (POST) routines, which are performed each time the system is powered on, errors may occur.

**Non-fatal errors** are those which, in most cases, allow the system to continue the boot-up process. The error messages normally appear on the screen.

**Fatal errors** are those which will not allow the system to continue the boot-up procedure. If a fatal error occurs, you should consult with SGI for possible repairs.

These fatal errors are usually communicated through a series of audible beeps. The numbers on the fatal error list correspond to the number of beeps for the corresponding error.

**Table B-1** BIOS Error Codes

Beep Code	Error Message	Description
1 beep	Refresh	Circuits have been reset. Ready to power up.
5 short beeps + 1 long beep	Memory error	No memory detected in the system
5 long beeps + 2 long beeps	Display memory read/write error	Video adapter missing or with faulty memory
1 continuous beep	System OH	System overheat

